



**THE DATASHEET OF
ZL40213LDF1**



Features

Inputs/Outputs

- Accepts differential or single-ended input
 - LVPECL, LVDS, CML, HCSL, LVCMOS
- On-chip input termination resistors and biasing for AC coupled inputs
- Two precision LVDS outputs
- Operating frequency up to 750 MHz

Power

- Options for 2.5 V or 3.3 V power supply
- Current consumption of 44 mA
- On-chip Low Drop Out (LDO) Regulator for superior power supply rejection

Performance

- Ultra low additive jitter of 78 fs RMS

Ordering Information

ZL40213LDG1	16 Pin QFN	Trays
ZL40213LDF1	16 Pin QFN	Tape and Reel
Matte Tin		
Package size: 3 x 3 mm		
-40°C to +85°C		

Applications

- General purpose clock distribution
- Low jitter clock trees
- Logic translation
- Clock and data signal restoration
- Wired communications: OTN, SONET/SDH, GE, 10 GE, FC and 10G FC
- Wireless communications
- High performance micro-processor clock distribution

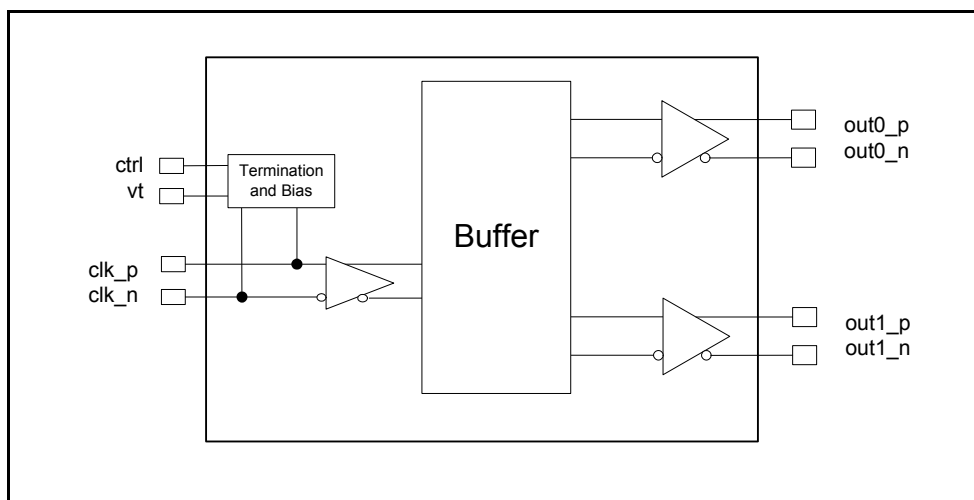

Figure 1 - Functional Block Diagram

Table of Contents

Features	1
Inputs/Outputs	1
Power	1
Performance	1
Applications	1
1.0 Package Description	4
2.0 Pin Description	4
3.0 Functional Description	5
3.1 Clock Inputs	5
3.2 Clock Outputs	10
3.3 Device Additive Jitter	13
3.4 Power Supply	14
3.4.1 Sensitivity to power supply noise	14
3.4.2 Power supply filtering	14
3.4.3 PCB layout considerations	14
4.0 AC and DC Electrical Characteristics	15
5.0 Performance Characterization	17
6.0 Typical Behavior	18
7.0 Package Thermal Characteristics	19
8.0 Mechanical Drawing	20

List of Figures

Figure 1 - Functional Block Diagram	1
Figure 2 - Pin Connections	4
Figure 3 - Simplified Diagram of input stage	5
Figure 4 - Clock Input - LVPECL - DC Coupled	6
Figure 5 - Clock Input - LVPECL - AC Coupled	6
Figure 6 - Clock Input - LVDS - DC Coupled	7
Figure 7 - Clock Input - LVDS - AC Coupled	7
Figure 8 - Clock Input - CML- AC Coupled	8
Figure 9 - Clock Input - HCSL- AC Coupled	8
Figure 10 - Clock Input - AC-coupled Single-Ended	9
Figure 11 - Clock Input - DC-coupled 3.3V CMOS.	9
Figure 12 - Simplified LVDS Output Driver.	10
Figure 13 - LVDS DC Coupled Termination (Internal Receiver Termination)	10
Figure 14 - LVDS DC Coupled Termination (External Receiver Termination)	11
Figure 15 - LVDS AC Coupled Termination	11
Figure 16 - LVDS AC Output Termination for CML Inputs	12
Figure 17 - Additive Jitter	13
Figure 18 - Decoupling Connections for Power Pins	14
Figure 19 - Differential Voltage Parameter.	16
Figure 20 - Input To Output Timing	16

1.0 Package Description

The device is packaged in a 16 pin QFN

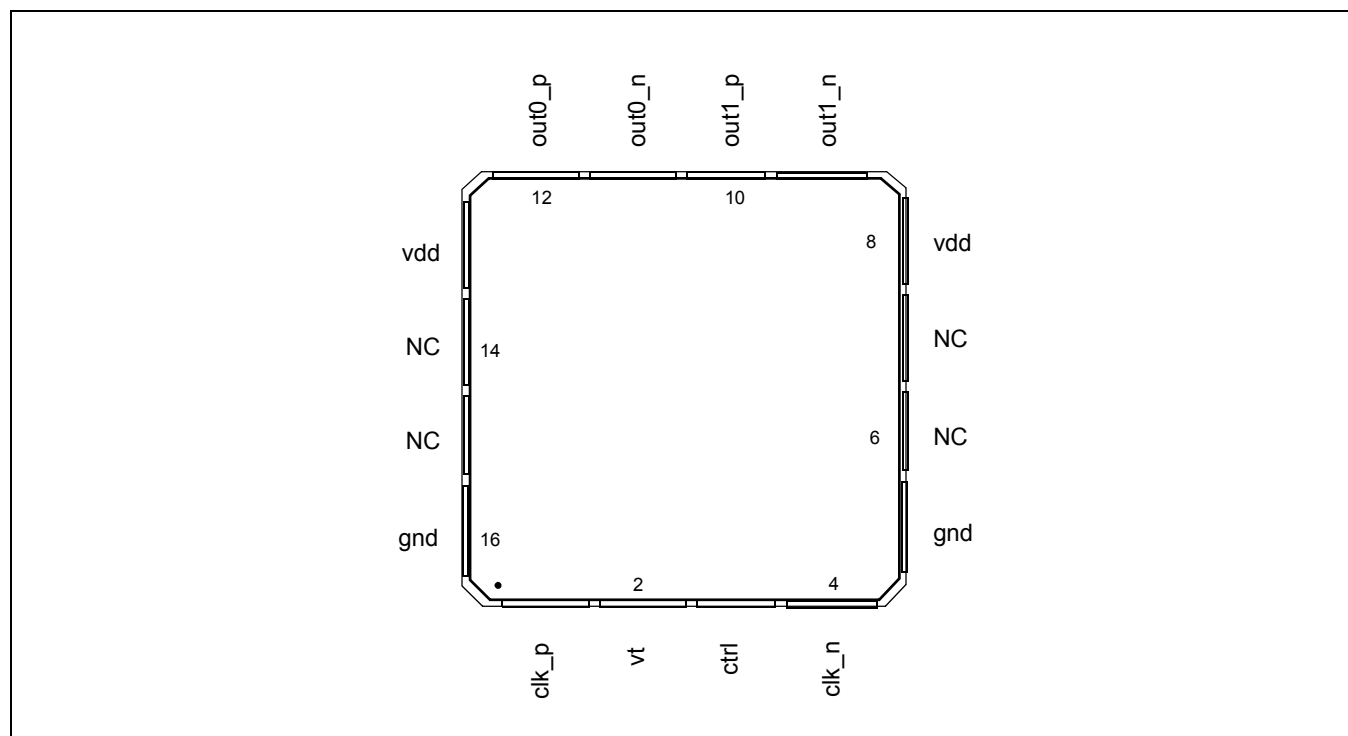

Figure 2 - Pin Connections

2.0 Pin Description

Pin #	Name	Description
1, 4	clk_p, clk_n,	Differential Input (Analog Input). Differential (or singled ended) input signals. For all input signal configuration see "Clock Inputs" on page 5
12, 11, 10, 9,	out0_p, out0_n out1_p, out1_n	Differential Output (Analog Output). Differential outputs.
8, 13	vdd	Positive Supply Voltage. 2.5 V _{DC} or 3.3 V _{DC} nominal.
5, 16	gnd	Ground. 0 V.
2	vt	On-Chip Input Termination Node (Analog). Center tap between internal 50 Ohm termination resistors. See "Clock Inputs" on page 5 for more information.
3	ctrl	Digital Control for On-Chip Input Termination (Input). Selects differential input mode; 0: DC coupled modes 1: AC coupled differential modes These pins are internally pulled down to GND. See "Clock Inputs" on page 5 for more information.
6, 7, 14, 15	NC	No connection. Leave unconnected.

3.0 Functional Description

The ZL40213 is an LVDS clock fanout buffer with two identical output clock drivers capable of operating at frequencies up to 750MHz.

The ZL40213 provides an internal input termination network for DC and AC coupled inputs; optional input biasing for AC coupled inputs is also provided. The ZL40213 can accept DC or AC coupled LVPECL and LVDS input signals, AC coupled CML or HCSL input signals, and single ended signals. A pin compatible device with external termination is also available.

The ZL40213 is designed to fan out low-jitter reference clocks for wired or optical communications applications while adding minimal jitter to the clock signal. An internal linear power supply regulator and bulk capacitors minimize additive jitter due to power supply noise. The device operates from 2.5V \pm 5% or 3.3V \pm 5% supply. Its operation is guaranteed over the industrial temperature range -40°C to +85°C.

The device block diagram is shown in Figure 1; its operation is described in the following sections.

3.1 Clock Inputs

The device has a differential input equipped with two on-chip 50 Ohm termination resistors arranged in series with a center tap. The input can accept many differential and single-ended signals with AC or DC coupling as appropriate. A control pin is available to enable internal biasing for AC coupled inputs. A block diagram of the input stage is in Figure 3.

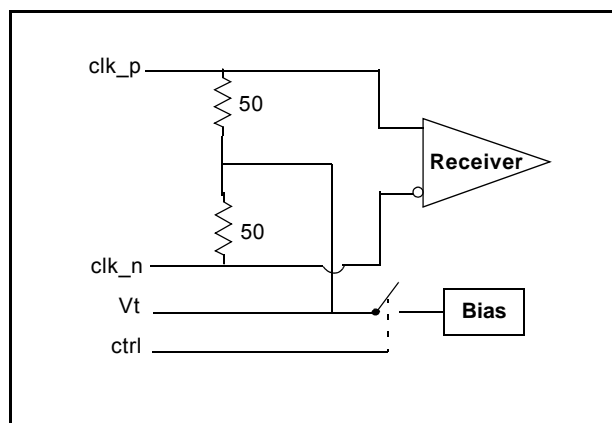

Figure 3 - Simplified Diagram of input stage

The following figures give the components values and configuration for the various circuits compatible with the input stage and the use of the *Vt* and *ctrl* pins in each case.

In the following diagrams where the *ctrl* pin is "1" and the *Vt* pin is not connected, the *Vt* pin can be instead connected to V_{DD} with a capacitor. The same capacitor can also help in Figure 4 between *Vt* and V_{DD} . This capacitor will minimize the noise at the point between the two internal termination resistors and improve the overall performance of the device.

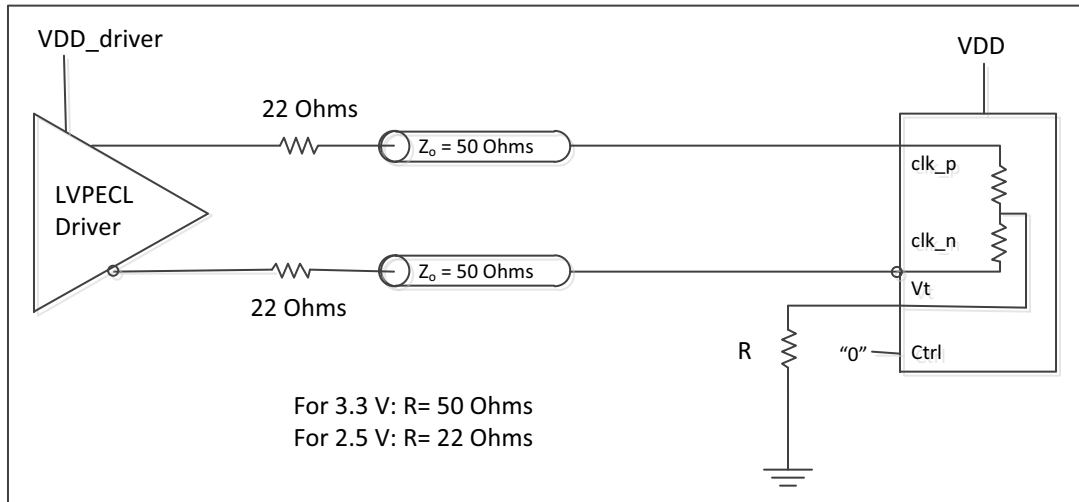

Figure 4 - Clock Input - LVPECL - DC Coupled

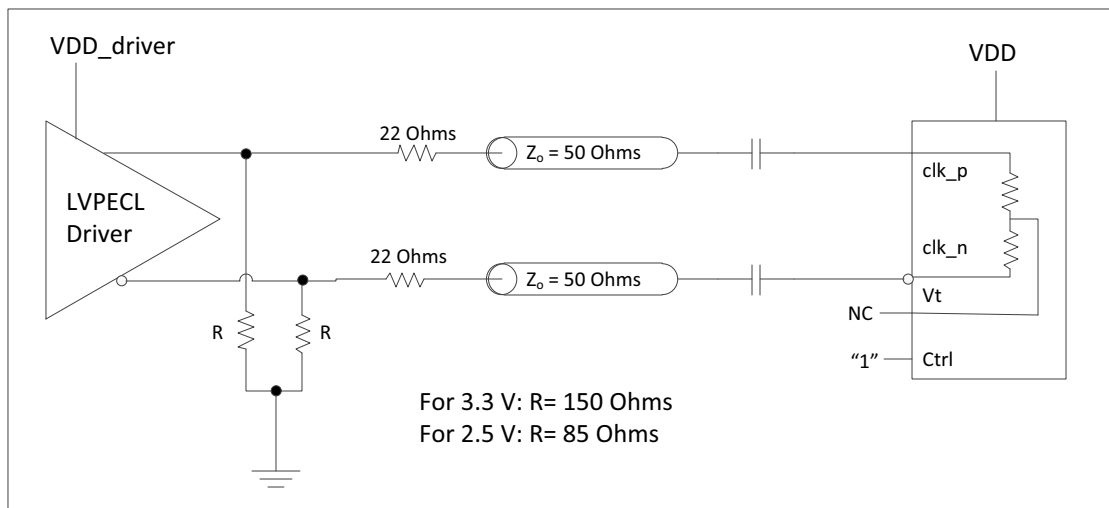

Figure 5 - Clock Input - LVPECL - AC Coupled

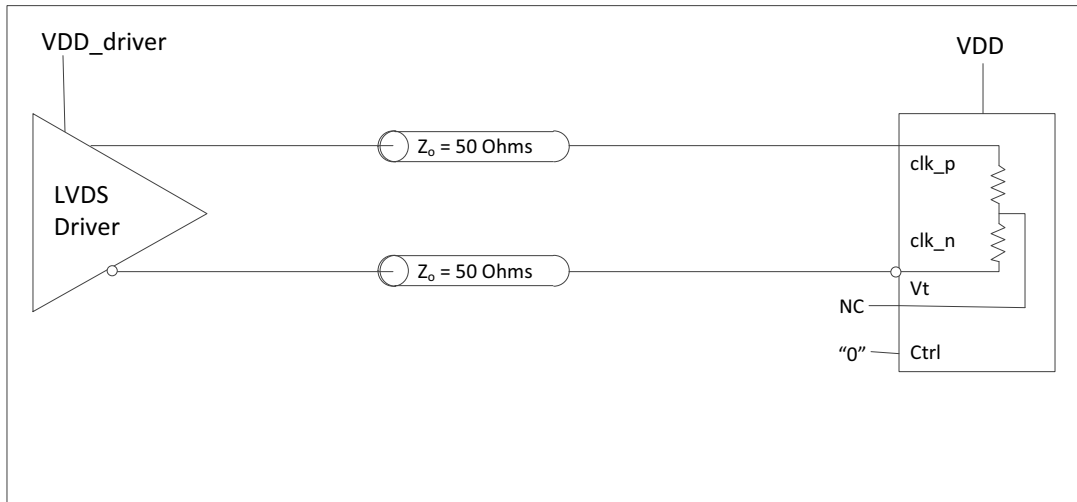

Figure 6 - Clock Input - LVDS - DC Coupled

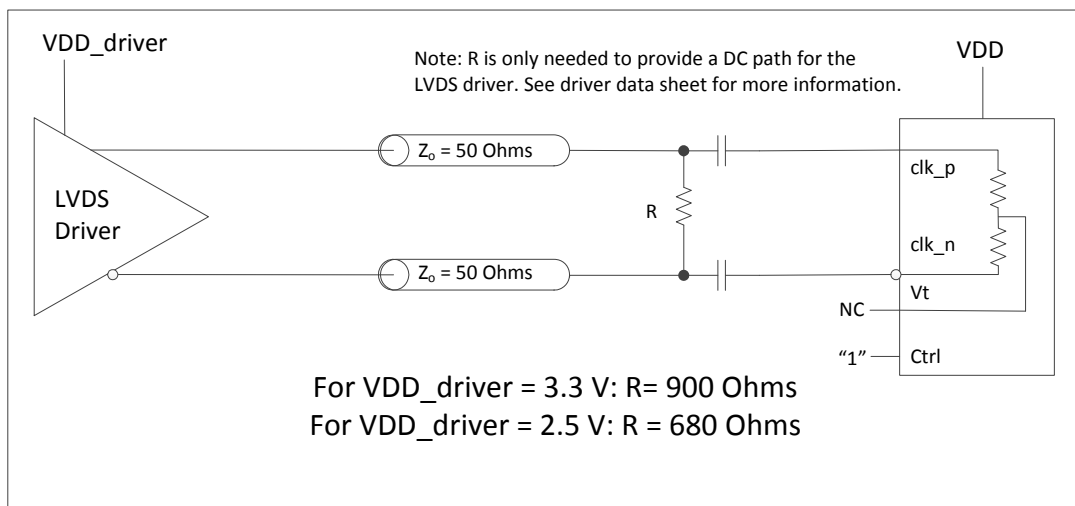

Figure 7 - Clock Input - LVDS - AC Coupled

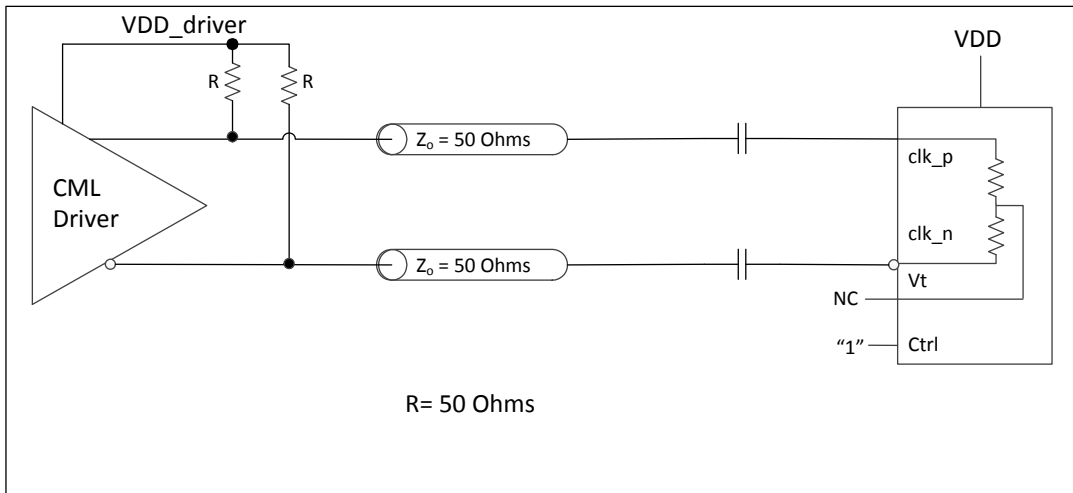

Figure 8 - Clock Input - CML- AC Coupled

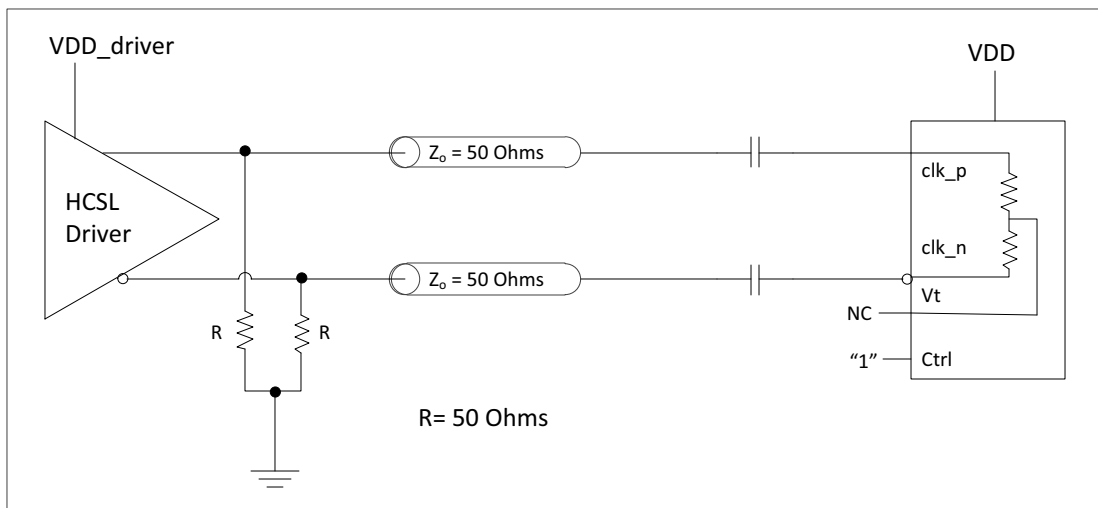

Figure 9 - Clock Input - HCSL- AC Coupled

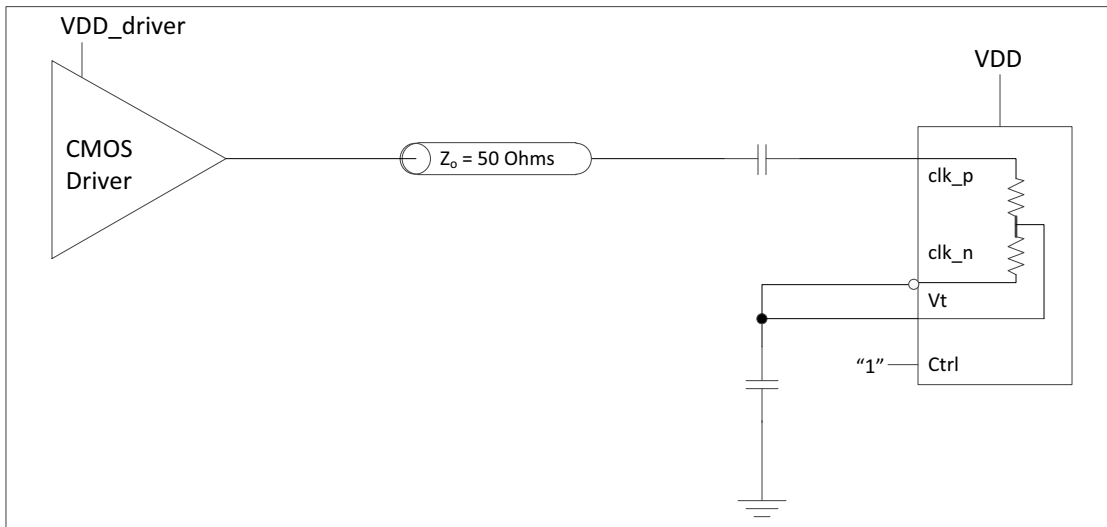

Figure 10 - Clock Input - AC-coupled Single-Ended

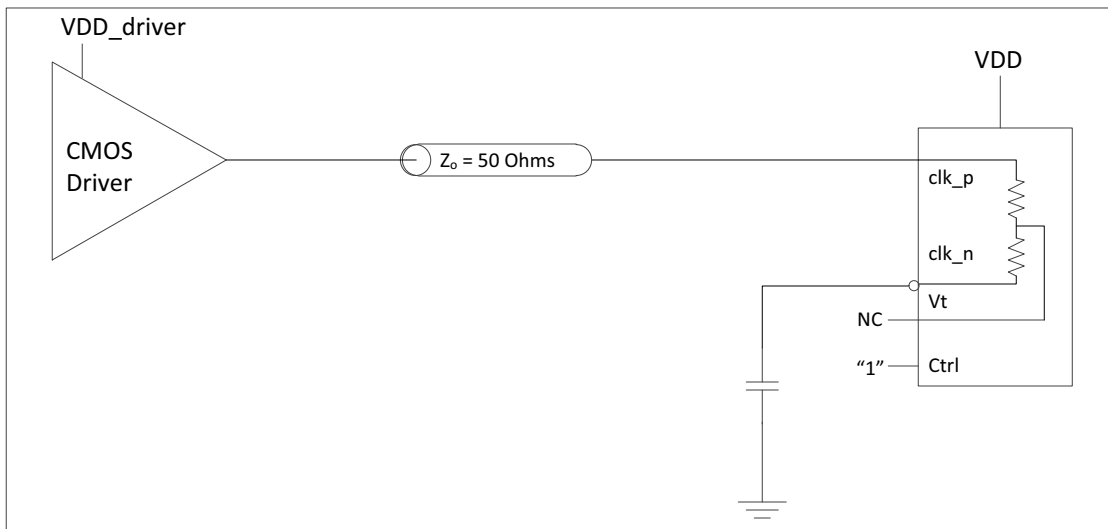

Figure 11 - Clock Input - DC-coupled 3.3V CMOS

3.2 Clock Outputs

LVDS has lower signal swing than LVPECL which results in a low power consumption. A simplified diagram for the LVDS output stage is shown in Figure 12.

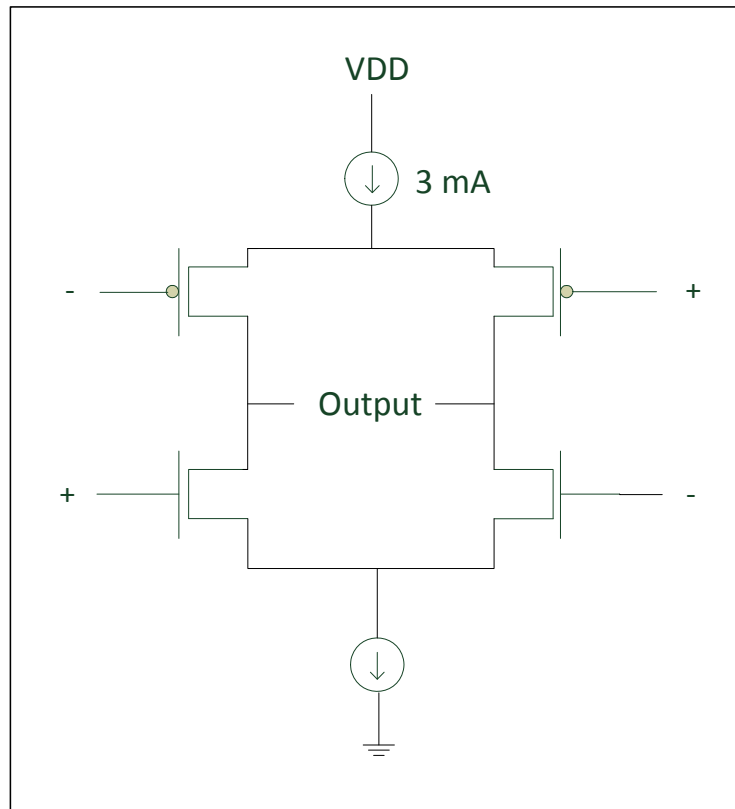

Figure 12 - Simplified LVDS Output Driver

The methods to terminate the ZL40213 drivers are shown in the following figures.

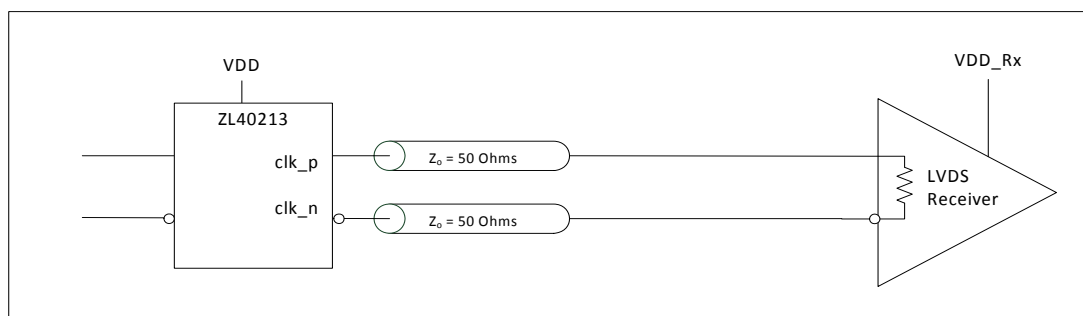

Figure 13 - LVDS DC Coupled Termination (Internal Receiver Termination)

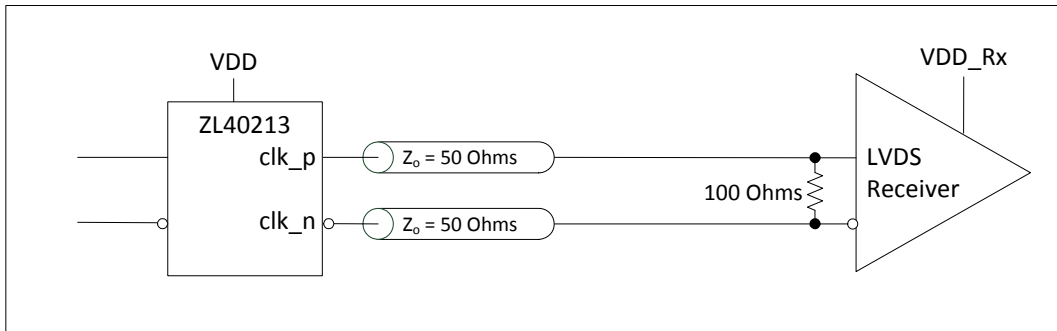

Figure 14 - LVDS DC Coupled Termination (External Receiver Termination)

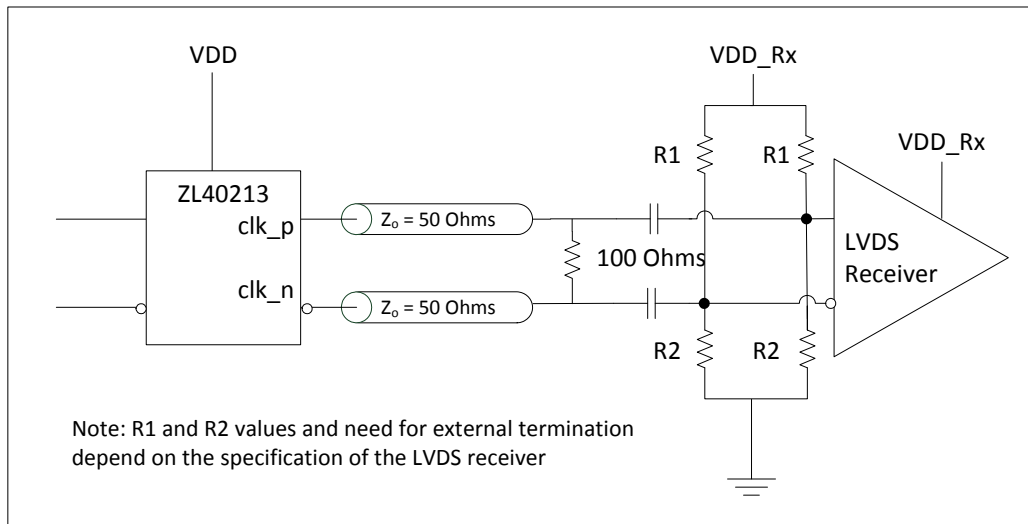

Figure 15 - LVDS AC Coupled Termination

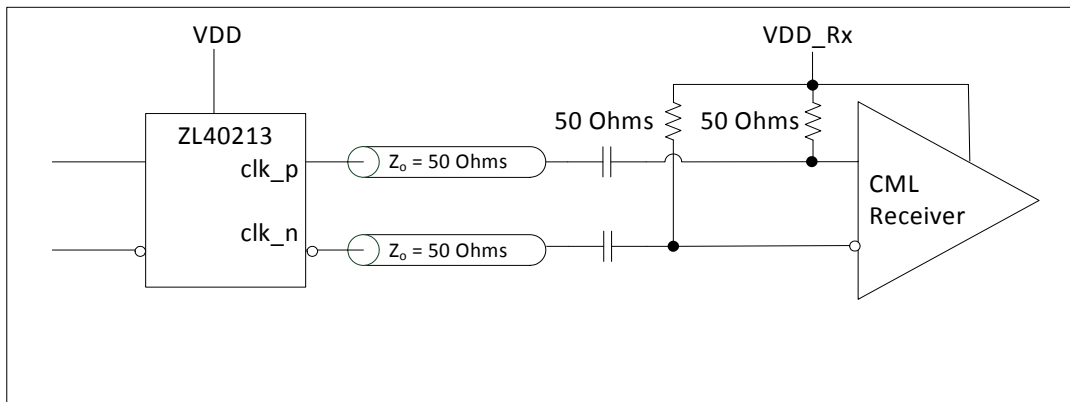

Figure 16 - LVDS AC Output Termination for CML Inputs

3.3 Device Additive Jitter

The ZL40213 clock fanout buffer is not intended to filter clock jitter. The jitter performance of this type of device is characterized by its additive jitter. Additive jitter is the jitter the device would add to a hypothetical jitter-free clock as it passes through the device. The additive jitter of the ZL40213 is random and as such it is not correlated to the jitter of the input clock signal.

The square of the resultant random RMS jitter at the output of the ZL40213 is equal to the sum of the squares of the various random RMS jitter sources including: input clock jitter; additive jitter of the buffer; and additive jitter due to power supply noise. There may be additional deterministic jitter sources, but they are not shown in Figure 17.

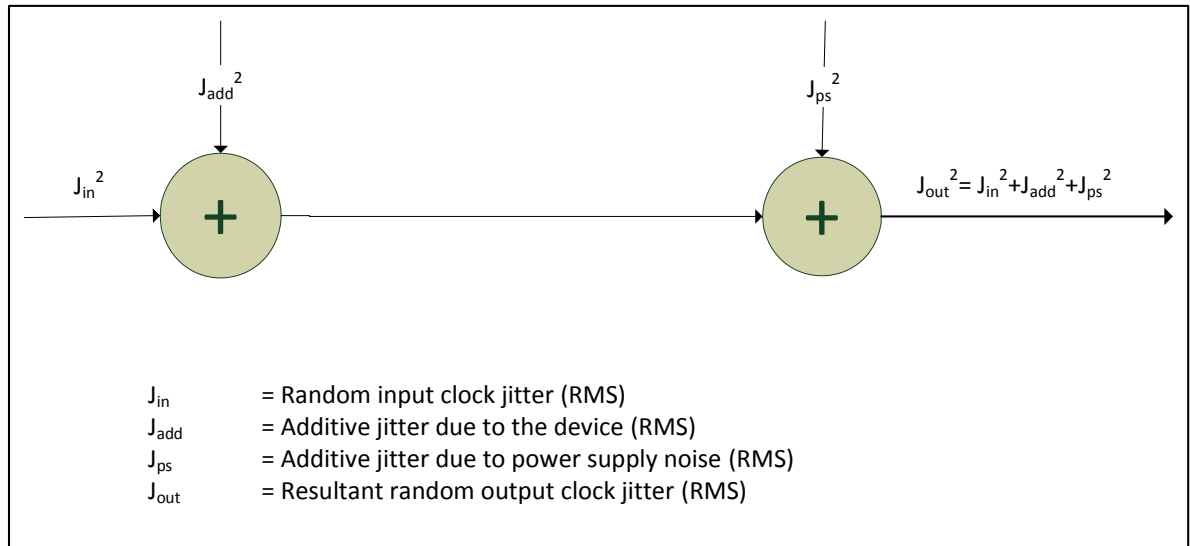

Figure 17 - Additive Jitter

3.4 Power Supply

This device operates with either a 2.5V supply or 3.3V supply.

3.4.1 Sensitivity to power supply noise

Power supply noise from sources such as switching power supplies and high-power digital components such as FPGAs can induce additive jitter on clock buffer outputs. The ZL40213 is equipped with a low drop out (LDO) power regulator and on-chip bulk capacitors to minimize additive jitter due to power supply noise. The LDO regulator on the ZL40213 allows this device to have superior performance even in the presence of external noise sources. The on-chip measures in combination with the simple recommended power supply filtering and PCB layout minimize the additive jitter from power supply noise.

The performance of these clock buffers in the presence of power supply noise is detailed in ZLAN-403, "Power Supply Rejection in Clock Buffers" which is available from Applications Engineering.

3.4.2 Power supply filtering

For optimal jitter performance, the device should be isolated from the power planes connected to its power supply pins as shown in Figure 18.

- 10 μF capacitors should be size 0603 or size 0805 X5R or X7R ceramic, 6.3 V minimum rating
- 0.1 μF capacitors should be size 0402 X5R ceramic, 6.3 V minimum rating
- Capacitors should be placed next to the connected device power pins
- a 0.3 ohm resistor is recommended for the filter shown in Figure 18

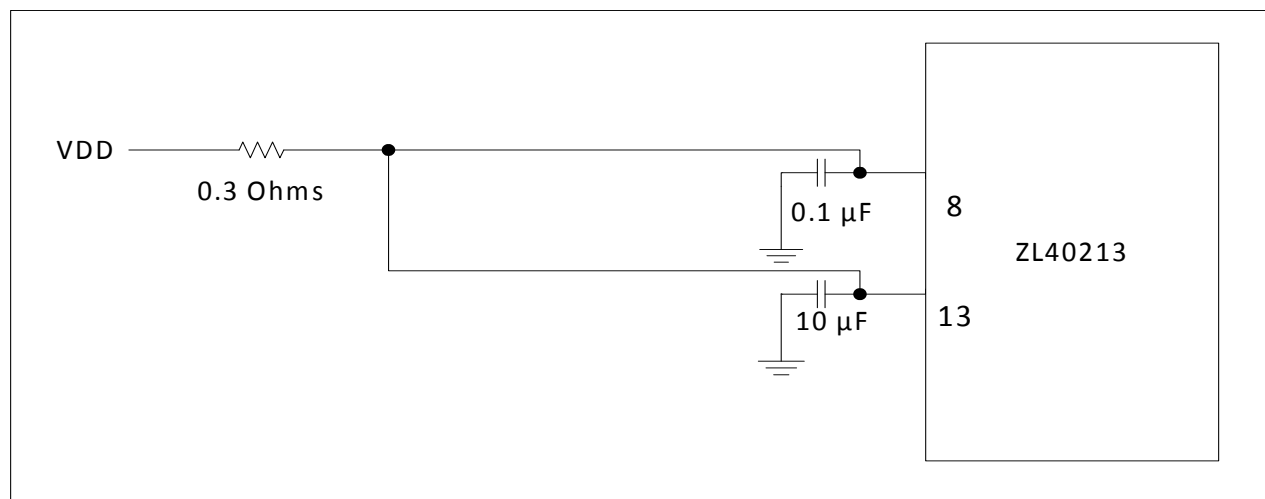

Figure 18 - Decoupling Connections for Power Pins

3.4.3 PCB layout considerations

The power nets in Figure 18 can be implemented either as a plane island or routed power topology without changing the overall jitter performance of the device.

4.0 AC and DC Electrical Characteristics

Absolute Maximum Ratings*

	Parameter	Sym.	Min.	Max.	Units
1	Supply voltage	V_{DD_R}	-0.5	4.6	V
2	Voltage on any digital pin	V_{PIN}	-0.5	V_{DD}	V
3	Soldering temperature	T		260	°C
4	Storage temperature	T_{ST}	-55	125	°C
5	Junction temperature	T_j		125	°C
6	Voltage on input pin	V_{input}		V_{DD}	V
7	Input capacitance each pin	C_p		500	fF

* Exceeding these values may cause permanent damage. Functional operation under these conditions is not implied.

* Voltages are with respect to ground (GND) unless otherwise stated

Recommended Operating Conditions*

	Characteristics	Sym.	Min.	Typ.	Max.	Units
1	Supply voltage 2.5 V mode	V_{DD25}	2.375	2.5	2.625	V
2	Supply voltage 3.3 V mode	V_{DD33}	3.135	3.3	3.465	V
3	Operating temperature	T_A	-40	25	85	°C

* Voltages are with respect to ground (GND) unless otherwise stated

DC Electrical Characteristics - Current Consumption

	Characteristics	Sym.	Min.	Typ.	Max.	Units	Notes
1	Supply current LVDS drivers - loaded (all outputs are active)	I_{dd_load}		44		mA	

DC Electrical Characteristics - Inputs and outputs - for 2.5/3.3 V supply

	Characteristics	Sym.	Min.	Typ.	Max.	Units	Notes
1	CMOS control logic high-level input	V_{CIH}	$0.7 \cdot V_{DD}$			V	
2	CMOS control logic low-level input	V_{CIL}			$0.3 \cdot V_{DD}$	V	
3	CMOS control logic Input leakage current	I_{IL}		1		μA	$V_I = V_{DD}$ or 0 V
4	Differential input common mode - supply voltage	V_{ICM}	1.1		1.6	V	For $V_{DD} = 2.5$
5	Differential input common mode - supply voltage	V_{ICM}	1.1		2.0	V	For $V_{DD} = 3.3$
6	LVDS Differential input voltage	V_{ID}	0.25		1	V	
7	Differential input resistance	V_{IR}	80	100	120	ohm	

DC Electrical Characteristics - Inputs and outputs - for 2.5/3.3 V supply

	Characteristics	Sym.	Min.	Typ.	Max.	Units	Notes
8	LVDS output differential voltage*	V_{OD}	0.25	0.30	0.40	V	
9	LVDS output common mode voltage	V_{CM}	1.1	1.25	1.375	V	

* The VOD parameter was measured from 125 MHz to 750 MHz.



Figure 19 - Differential Voltage Parameter

AC Electrical Characteristics* - Inputs and Outputs (see Figure 20) - for 2.5/3.3 V supply.

	Characteristics	Sym.	Min.	Typ.	Max.	Units	Notes
1	Maximum Operating Frequency	$1/t_p$			750	MHz	
2	input to output clock propagation delay	t_{pd}	0	1	2	ns	
3	output to output skew	$t_{out2out}$		50	100	ps	
4	part to part output skew	$t_{part2part}$		80	300	ps	
5	Output clock Duty Cycle degradation	t_{PWH}/ t_{PWL}	-5	0	5	%	
6	LVDS Output slew rate	r_{sl}	0.55			V/ns	

* Supply voltage and operating temperature are as per Recommended Operating Conditions

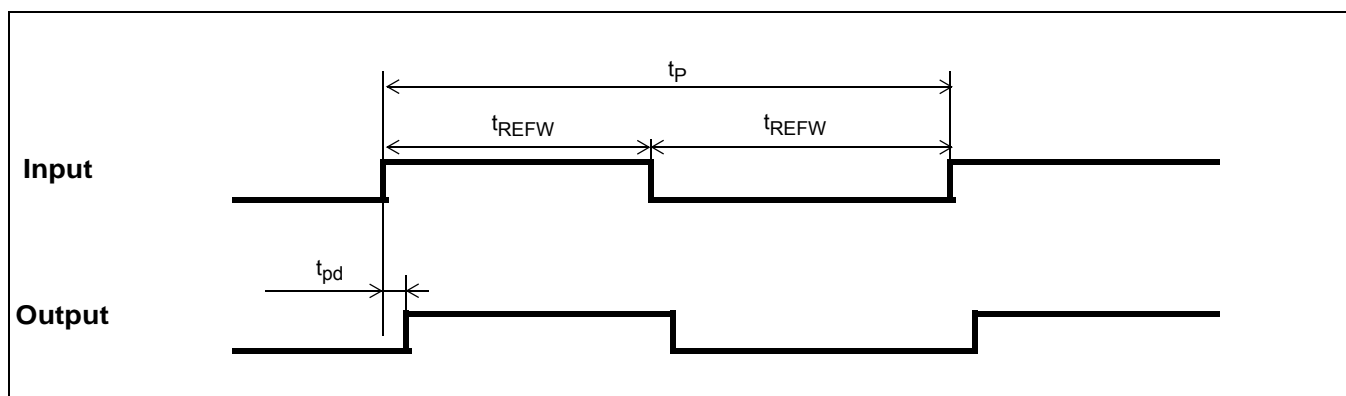

Figure 20 - Input To Output Timing

5.0 Performance Characterization

Additive Jitter at 2.5 V*

	Output Frequency (MHz)	Jitter Measurement Filter	Typical (fs)	Notes
1	125	12 kHz - 20 MHz	120	
2	212.5	12 kHz - 20 MHz	102	
3	311.04	12 kHz - 20 MHz	88	
4	425	12 kHz - 20 MHz	91	
5	500	12 kHz - 20 MHz	77	
6	622.08	12 kHz - 20 MHz	78	
7	750	12 kHz - 20 MHz	78	

*The values in this table were taken with a slew rate of approximately 0.8 V/ns.

Additive Jitter at 3.3 V*

	Output Frequency (MHz)	Jitter Measurement Filter	Typical (fs)	Notes
1	125	12 kHz - 20 MHz	123	
2	212.5	12 kHz - 20 MHz	104	
3	311.04	12 kHz - 20 MHz	92	
4	425	12 kHz - 20 MHz	94	
5	500	12 kHz - 20 MHz	78	
6	622.08	12 kHz - 20 MHz	79	
7	750	12 kHz - 20 MHz	80	

*The values in this table were taken with a slew rate of approximately 0.8 V/ns.

Additive jitter in the presence of power supply noise*

Carrier frequency	Parameter	Typical	Units	Notes
125	25 mV at 100 kHz	38	fs RMS	
750	25 mV at 100 kHz	50	fs RMS	

* The values in this table are the additive periodic jitter caused by an interfering tone typically caused by a switching power supply. For this test, measurements were taken over the full temperature and voltage range for $V_{DD} = 3.3$ V. The magnitude of the interfering tone is measured at the DUT.

6.0 Typical Behavior

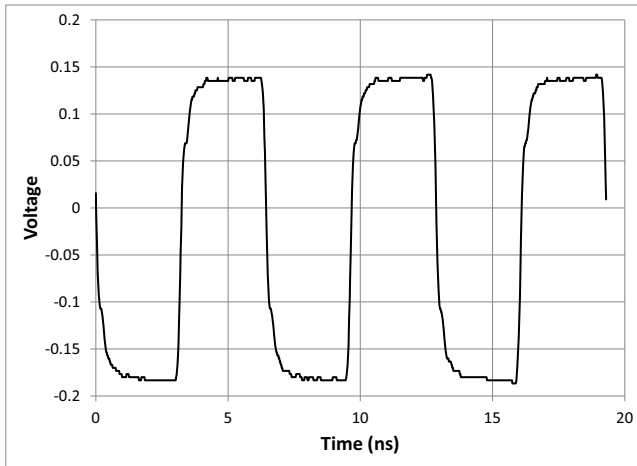

Typical Waveform at 155.52 MHz

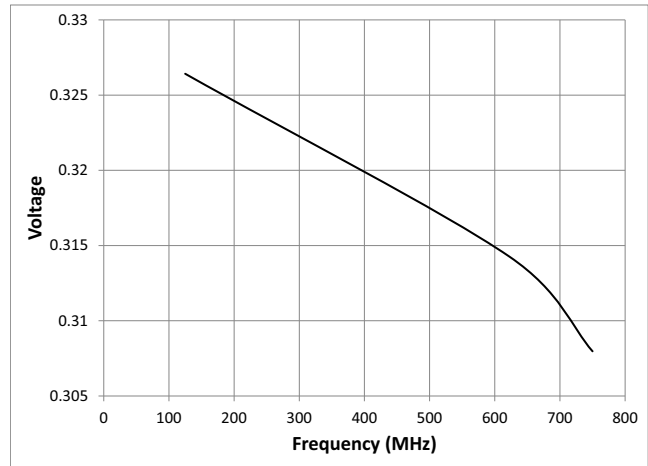

V_{OD} versus Frequency

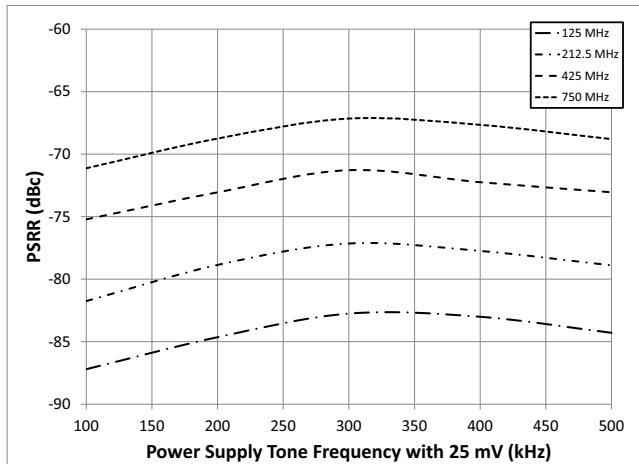

Power Supply Tone Frequency versus PSRR

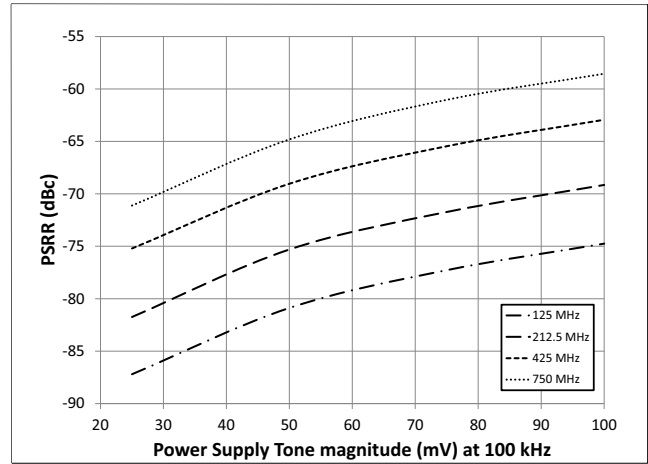

Power Supply Tone Magnitude versus PSRR

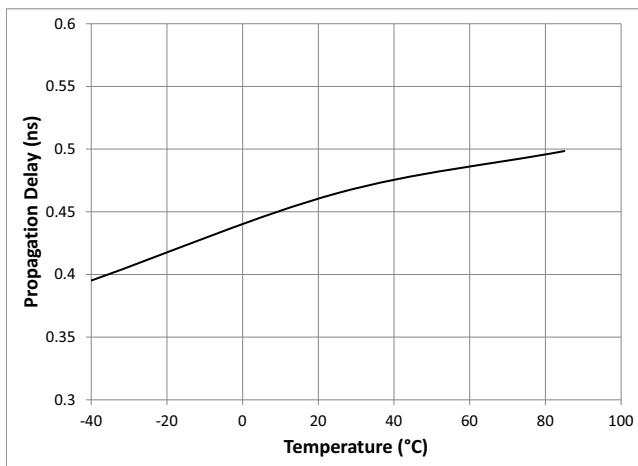

Propagation Delay versus Temperature

Note: This is for a single device. For more details see the characterization section.

7.0 Package Thermal Characteristics

Thermal Data

Parameter	Symbol	Test Condition	Value	Unit
Junction to Ambient Thermal Resistance	Θ_{JA}	Still Air	67.9	$^{\circ}\text{C}/\text{W}$
		1 m/s	61.6	
		2 m/s	58.1	
Junction to Case Thermal Resistance	Θ_{JC}	Still Air	44.1	$^{\circ}\text{C}/\text{W}$
Junction to Board Thermal Resistance	Θ_{JB}	Still Air	23.2	$^{\circ}\text{C}/\text{W}$
Maximum Junction Temperature*	T_{jmax}		125	$^{\circ}\text{C}$
Maximum Ambient Temperature	T_A		85	$^{\circ}\text{C}$

* Proper thermal management must be practiced to ensure that T_{jmax} is not exceeded.

8.0 Mechanical Drawing

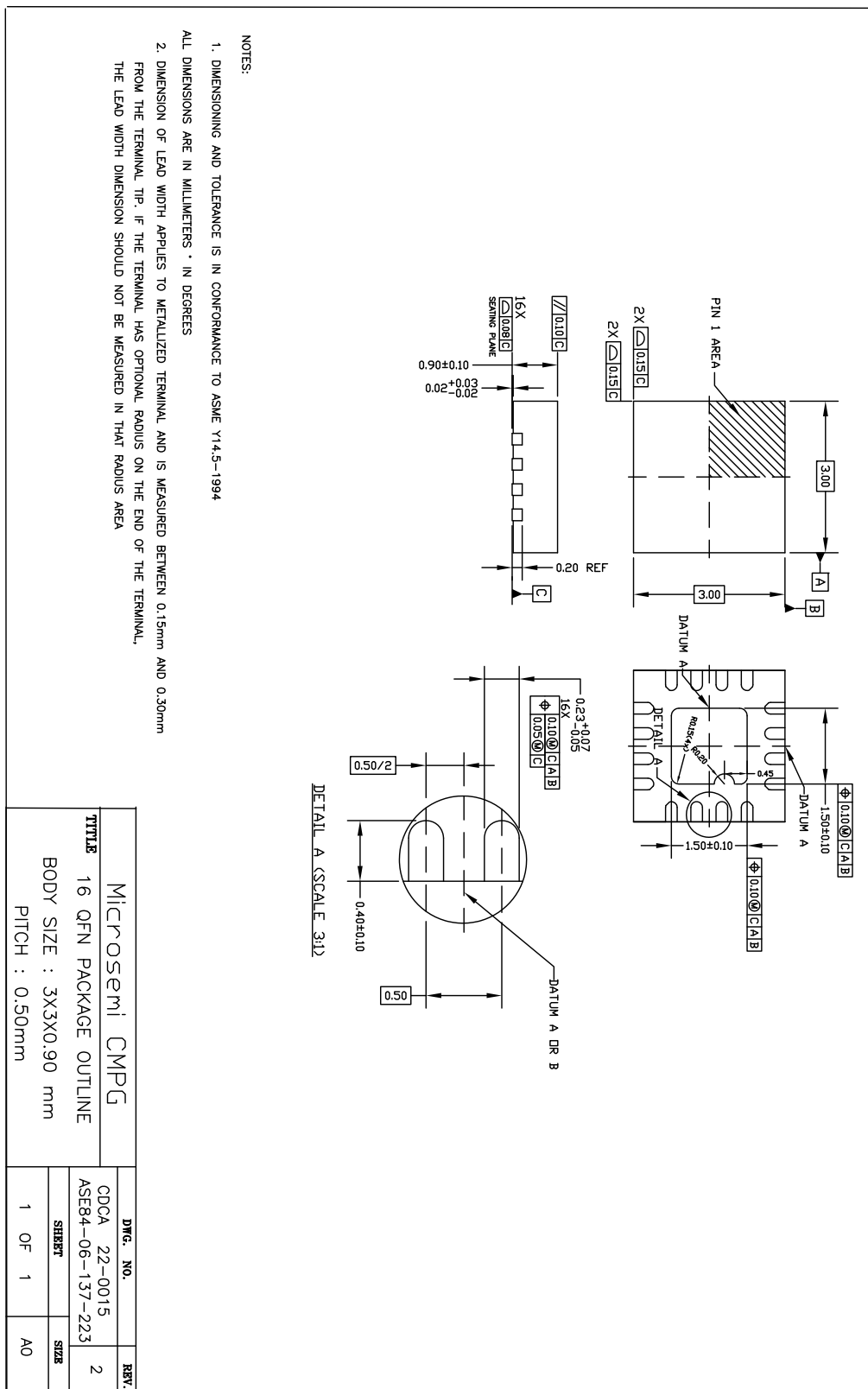



**For more information about all Microsemi products
visit our Web Site at**

www.microsemi.com

Information relating to products and services furnished herein by Microsemi Corporation or its subsidiaries (collectively "Microsemi") is believed to be reliable. However, Microsemi assumes no liability for errors that may appear in this publication, or for liability otherwise arising from the application or use of any such information, product or service or for any infringement of patents or other intellectual property rights owned by third parties which may result from such application or use. Neither the supply of such information or purchase of product or service conveys any license, either express or implied, under patents or other intellectual property rights owned by Microsemi or licensed from third parties by Microsemi, whatsoever. Purchasers of products are also hereby notified that the use of product in certain ways or in combination with Microsemi, or non-Microsemi furnished goods or services may infringe patents or other intellectual property rights owned by Microsemi.

This publication is issued to provide information only and (unless agreed by Microsemi in writing) may not be used, applied or reproduced for any purpose nor form part of any order or contract nor to be regarded as a representation relating to the products or services concerned. The products, their specifications, services and other information appearing in this publication are subject to change by Microsemi without notice. No warranty or guarantee express or implied is made regarding the capability, performance or suitability of any product or service. Information concerning possible methods of use is provided as a guide only and does not constitute any guarantee that such methods of use will be satisfactory in a specific piece of equipment. It is the user's responsibility to fully determine the performance and suitability of any equipment using such information and to ensure that any publication or data used is up to date and has not been superseded. Manufacturing does not necessarily include testing of all functions or parameters. These products are not suitable for use in any medical **and other** products whose failure to perform may result in significant injury or death to the user. All products and materials are sold and services provided subject to Microsemi's conditions of sale which are available on request.

Purchase of Microsemi's I2C components conveys a license under the Philips I2C Patent rights to use these components in an I2C System, provided that the system conforms to the I2C Standard Specification as defined by Philips.

Microsemi, ZL, and combinations thereof, VoiceEdge, VoicePort, SLAC, ISLIC, ISLAC and VoicePath are trademarks of Microsemi Corporation.

TECHNICAL DOCUMENTATION - NOT FOR RESALE

Looking for pricing, stock, or lifecycle information?

Click below to explore more details on WIN SOURCE:

- ⊖ [View ZL40213LDF1 on WIN SOURCE](#)
- ⊖ [Microchip Technology Information](#)

Optimize Your Supply Chain with WIN SOURCE Solutions

- ✓ Global Sourcing Solution
- ✓ Obsolete Management
- ✓ Cost Control Management
- ✓ Shortage Management
- ✓ Alternative Solution
- ✓ Excess Inventory Management