



**THE DATASHEET OF
MAX77812EVKIT#**



Evaluates: MAX77812

MAX77812 Evaluation Kit

General Description

The MAX77812 evaluation kit (EV kit) is a fully assembled and tested printed circuit board (PCB) that demonstrates the MAX77812. The EV kit allows for easy evaluation of each feature. It supports user-programmable phase configuration to one of five options:

- Single output in 4 phase configuration (default)
- Dual outputs in 3 + 1 phase configuration
- Dual outputs in 2 + 2 phase configuration
- Three outputs in 2 + 1 + 1 phase configuration
- Four outputs in 1 + 1 + 1 + 1 phase configuration

A Micro-B USB cable can be connected between the EV kit and a PC for easy testing of the I²C interface. Windows®-based software provides a user-friendly interface to exercise the features of the MAX77812. This software offers a graphical user interface (GUI) as well as a register-based interface.

[Ordering Information](#) appears at end of data sheet.

Features

- 20A Maximum Output Current (5A per phase)
- V_{IN} Range: 2.5V to 5.5V
- V_{OUT} Range: 0.250V to 1.525V with 5mV Steps
- ±0.5% Initial Output Accuracy with Differential Sensing
- 5 User-selectable Phase Configurations
- 91% Peak Efficiency (V_{IN} = 3.8V, V_{OUT} = 1.1V)
- Auto (SKIP/PWM) and Forced PWM Modes
- Enhanced Load Transient Response
- Programmable Ramp-up/down Slew Rates
- Programmable Startup/Shutdown Sequence
- UVLO, Short-Circuit, and Thermal Protections
- 2 User-programmable General-Purpose Inputs
- 3.4MHz High Speed I²C and 30MHz SPI Interface
- 3.408mm x 3.368mm 64-Bumps WLP Package

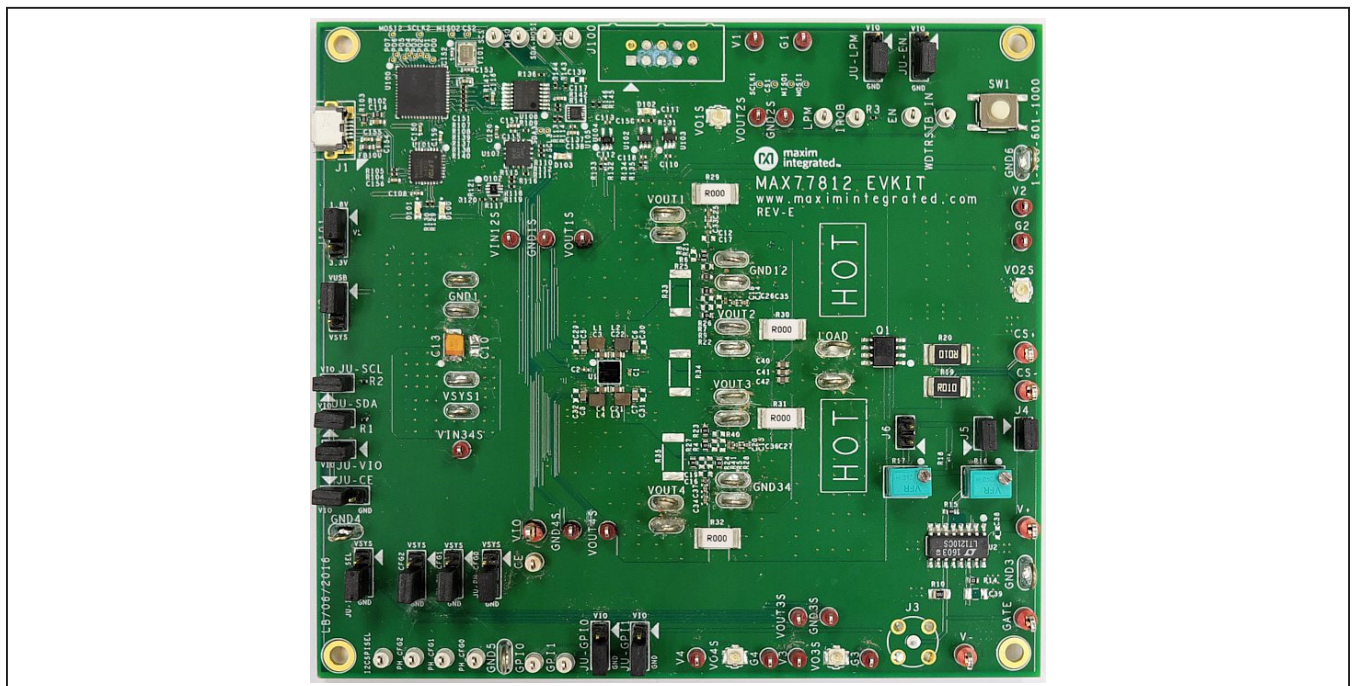

Figure 1. MAX77812 EV Kit Photo

Windows is a registered trademark and registered service mark of Microsoft Corporation.

19-8549; Rev 8; 5/23

Default Configurations

- $V_{OUT} = 0.65V$
- $I_{OUT} = 20A$ maximum
- Phase/Output configuration set to 1-Output: 4-Phase (Master 1)
- Chip Enable input (CE) is enabled
- Global Enable input (EN) is disabled
- Global Low Power Mode input (LPM) is disabled
- Serial Interface Selection input (I2C_SPI_SEL) set to I2C
- Default register settings
 - Auto SKIP/PWM mode is enabled
 - Enhanced transient response (ETR) is enabled
 - Startup delay and shutdown delay set to 0
 - Soft start slew rate and ramp-up slew rate set to $20mV/\mu s$
 - Shutdown slew rate and ramp-down slew rate set to $5mV/\mu s$
- Default shunt and jumper positions as shown in [Table 1](#)

Quick Start

Required Equipment

The MAX77812 evaluation package includes:

- MAX77812 EV kit
- Micro-B USB cable
- MAX77812 EV kit software (GUI)
- Adjustable DC power supply capable of supplying 12A
- Electronic load capable of sinking 20A
- Oscilloscope
- Two voltmeters
- Two ammeters

Note: In the following sections, software-related items are identified by bolding. Text in **bold** only refers to items directly from the EV kit software. Text in **bold and underlined** refers to items from the Windows OS.

Procedure

The EV kit is fully assembled and tested. Follow the steps below to verify board operation:

- 1) Identify the connections and test points shown in [Figure 2](#). Confirm all shunts and jumpers are at their default positions as indicated in [Table 1](#).
- 2) Install the MAX77812 EV kit software (GUI) on to your PC as instructed. Connect the Micro-B USB cable between PC and MAX77812 EV kit.
- 3) Set up the test circuit as shown in [Figure 3](#). Preset the DC power supply to 3.8V and current limit to 0.5A. **Do not turn on the power supply until all connections are completed.**
- 4) Enable the power supply output and confirm the input current is low ($< 100\mu A$). Open the MAX77812 GUI window and click on **Device** then **Connect**. If the connection is successful, it displays the message **Currently connected to MINIQUSB CMOD and DEVICE MAX77812**. Click **Read and close** ([Figure 4](#)).
- 5) Go to the **Buck** then **Master 1** tab and select the following settings ([Figure 5](#)):
 - Buck Master1 Output** to **1 = Enabled**
 - Buck Master1 Output Voltage** to **1000mV**Click **Write**.
- 6) Verify that the voltage at V1 is approximately 1V.
- 7) AC measurements, e.g., output ripple and load transient can be monitored using oscilloscope at VO1S.

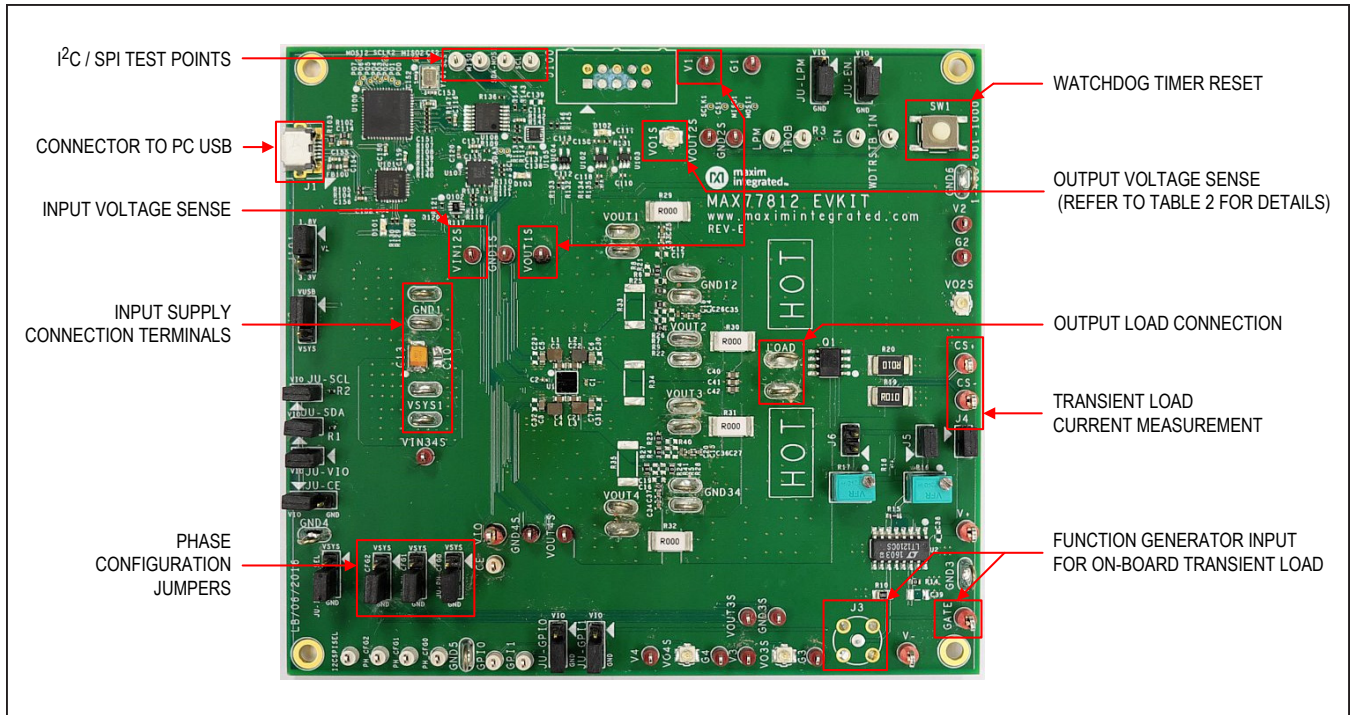

Figure 2. MAX77812 EV Kit Description

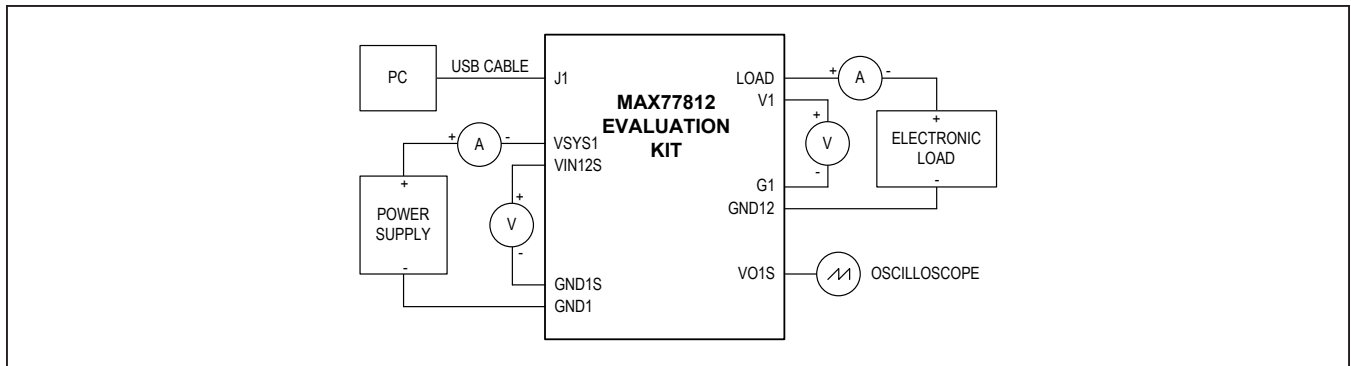

Figure 3. Quick Start Connection Diagram

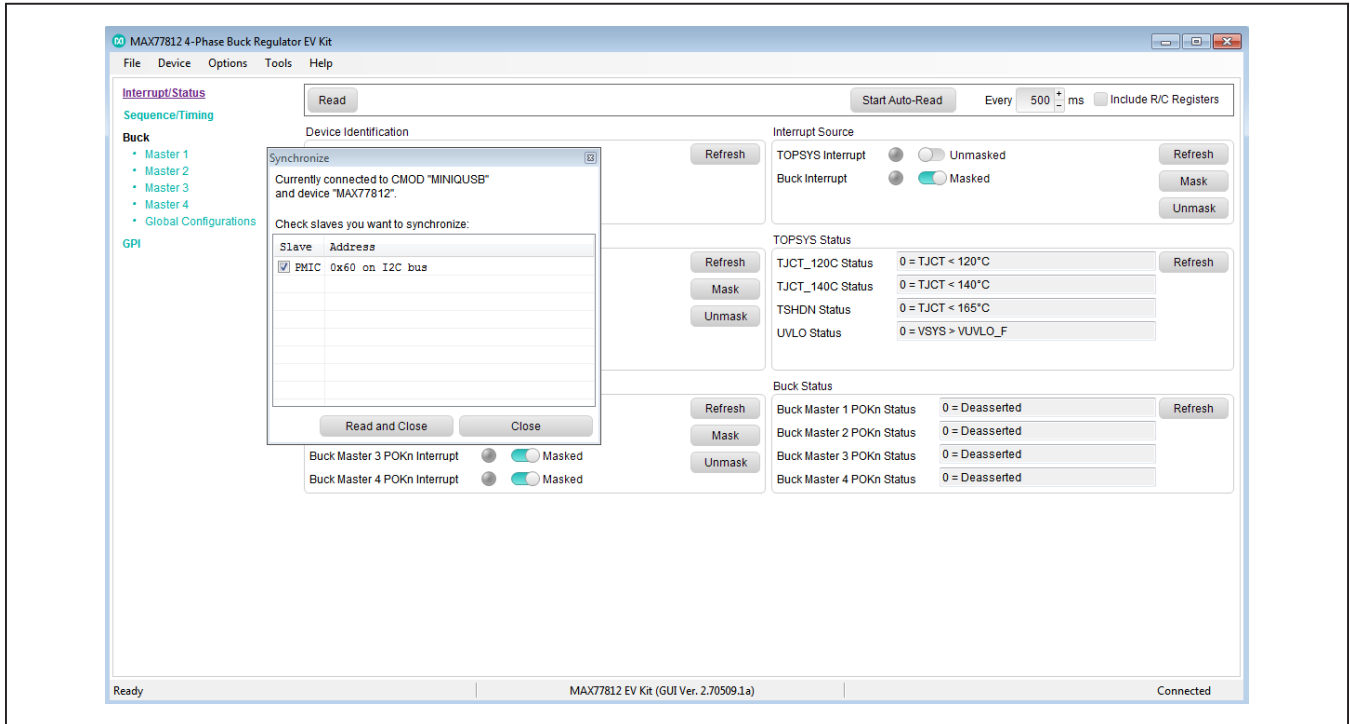

Figure 4. MAX77812 EV Kit GUI Connection

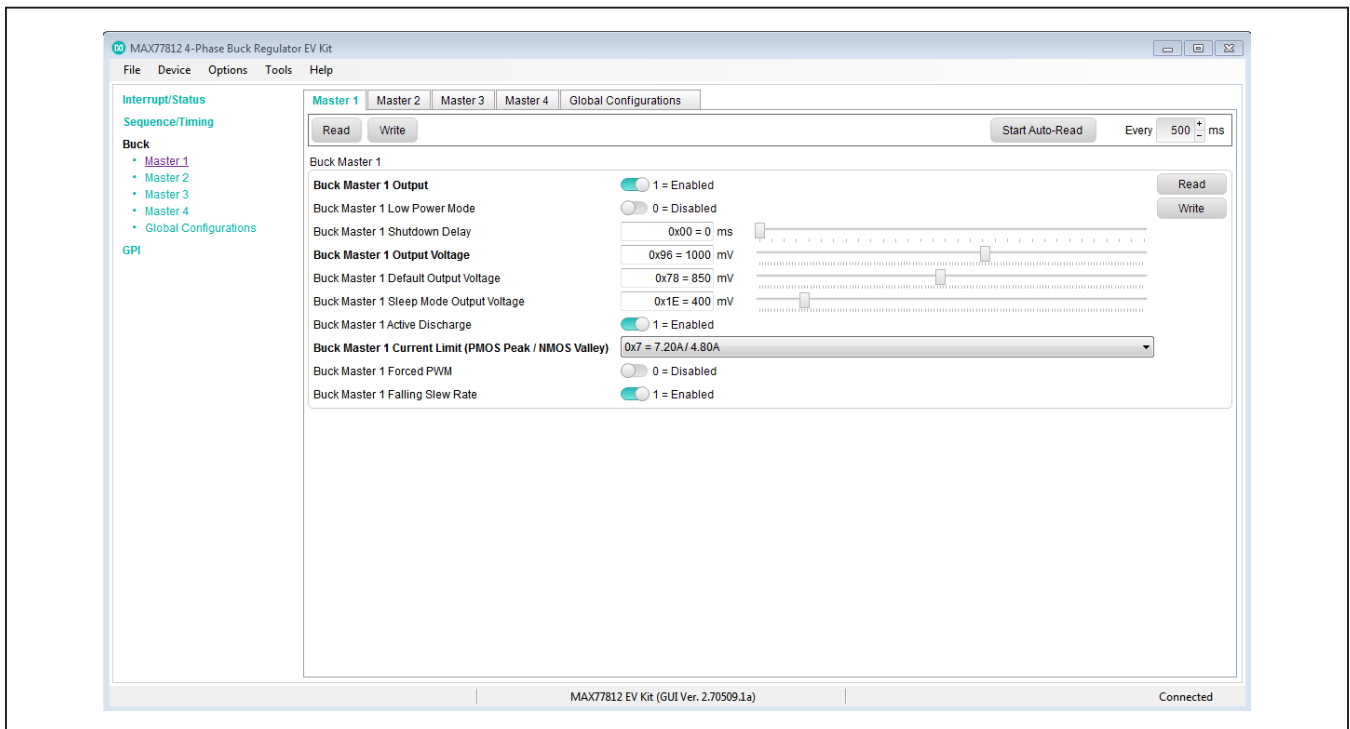

Figure 5. MAX77812 EV Kit GUI V_{OUT} Enable

Detailed Description of Hardware and Software

AC and DC Measurement Points

The EV kit has various optimized test points for AC and DC measurements to evaluate performance during load transient, output voltage ripple, load regulation, line regulation, output voltage accuracy and efficiency. These recommended test points are summarized in [Table 2](#).

Table 1. Default Shunt Positions and Jumper Descriptions

REFERENCE DESIGNATOR	DEFAULT POSITION	FUNCTION
JU-CE	1-2	Chip enable
JU-EN	2-3	Global enable
JU-LPM	2-3	Global low power mode
JU-GPI0	2-3	GPI0 input
JU-GPI1	2-3	GPI1 input
JU-SCL	CLOSE	SCL pullup
JU-SDA	CLOSE	SDA pullup
JU-VIO	CLOSE	On-board VIO supply
J2 (MINIQ Supply)	1-2	V _{USB} supply
J101 (V _L Supply)	1-2	1.8V supply
J4	CLOSE	On-board transient load supply
J5	CLOSE	On-board transient load adjustment
J6	OPEN	On-board transient load adjustment
JU-I2C_SPI_SEL	2-3	Select I ² C
JU-PH_CFG2	2-3	Select 4-phase configuration
JU-PH_CFG1	2-3	
JU-PH_CFG0	2-3	

Table 2. Test Points

CONFIGURATION	LOAD TRANSIENT, OUTPUT RIPPLE	LOAD REGULATION, LINE REGULATION, VOUT ACCURACY	EFFICIENCY	
			OUTPUT VOLTAGE	INPUT VOLTAGE
4 Phase	VO1S	V1/G1	VOUT1S/GND1S	VIN12S/GND1S
3 + 1 Phase	VO1S, VO4S	V1/G1, V4/G4	VOUT1S/GND1S, VOUT4S/GND4S	VIN12S/GND1S, VIN34S/GND4S
2 + 2 Phase	VO1S, VO3S	V1/G1, V3/G3	VOUT1S/GND1S, VOUT3S/GND3S	VIN12S/GND1S, VIN34S/GND3S
2 + 1 + 1 Phase	VO1S, VO3S, VO4S	V1/G1, V3/G3, V4/G4	VOUT1S/GND1S, VOUT3S/GND3S, VOUT4S/GND4S	VIN12S/GND1S, VIN34S/GND3S, VIN34S/GND4S
1 + 1 + 1 + 1 Phase	VO1S, VO2S, VO3S, VO4S	V1/G1, V2/G2, V3/G3, V4/G4	VOUT1S/GND1S, VOUT2S/GND2S, VOUT3S/GND3S, VOUT4S/GND4S	VIN12S/GND1S, VIN12S/GND2S, VIN34S/GND3S, VIN34S/GND4S

Load Transient Testing

The MAX77812 EV kit has an on-board circuit to create fast load transients. Measurements should be done at VO1S. This enables SNS1P/SNS1N signals to sense directly across the output capacitor near the transient load for more accurate measurements. Connect a signal generator output (1.6V, 1kHz square, 20% duty cycle) to J3 to drive the on-board circuit. If needed, adjust the signal generator output and variable resistor R16 to change the load current level and slew rate.

To use the on-board fast-load transient circuit in other phase configurations, first program the EV kit as described in the [Phase/Output Configuration Programming](#) section, then follow the guidance in [Table 3](#) and [Table 4](#) to select the desired master to connect to the on-board transient load output.

GUI Programmable Features

The MAX77812 requires the use of the GUI to fully exercise the capabilities of the device. The MAX77812 features a number of different programmable options to customize the behavior of the buck regulator during startup, operation, and shutdown. [Figure 6](#) and [Figure 7](#) show the various GUI window settings to configure the MAX77812 to enable these options.

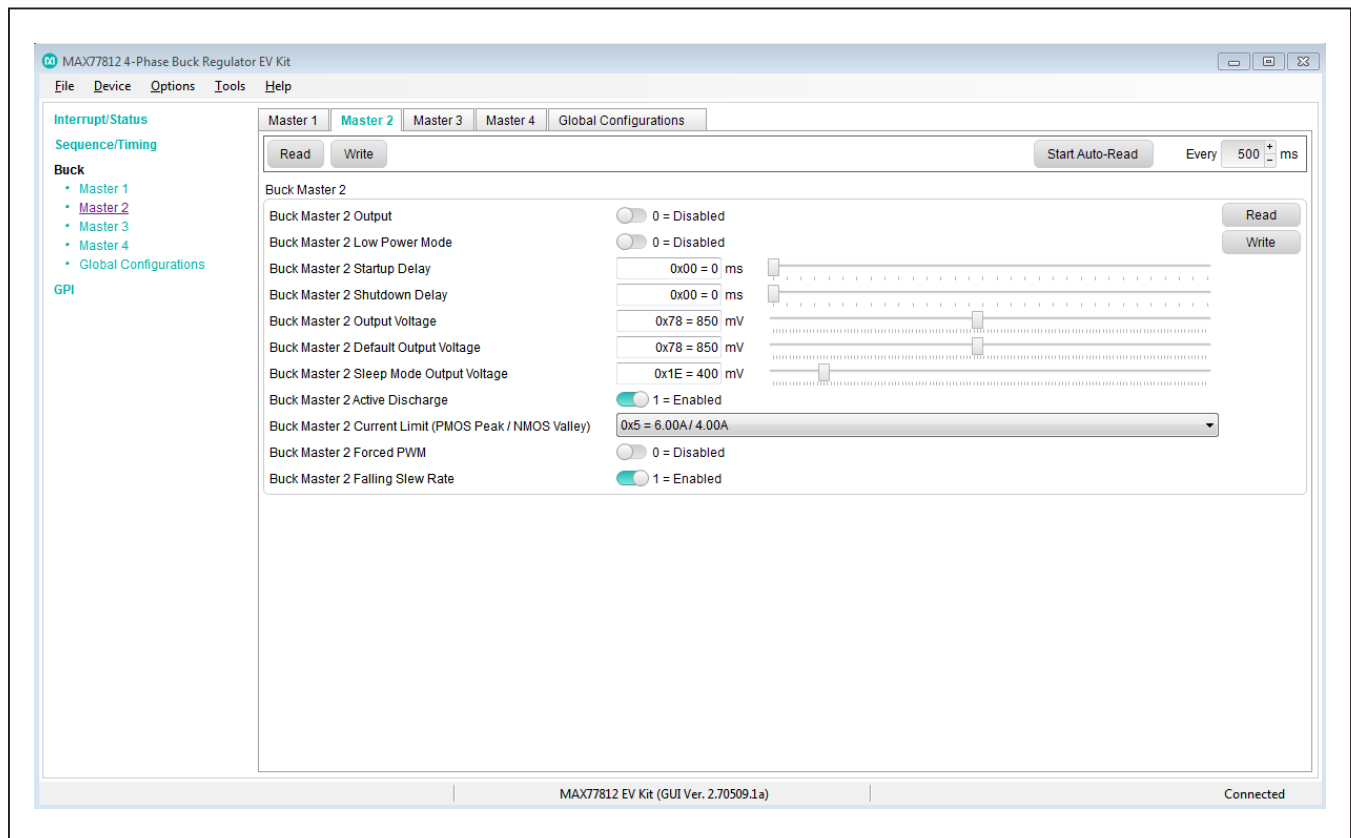

Figure 6. MAX77812 EV Kit Startup/Shutdown Delay, Low Power Mode, Forced PWM, Active Discharge, Output Voltage Settings

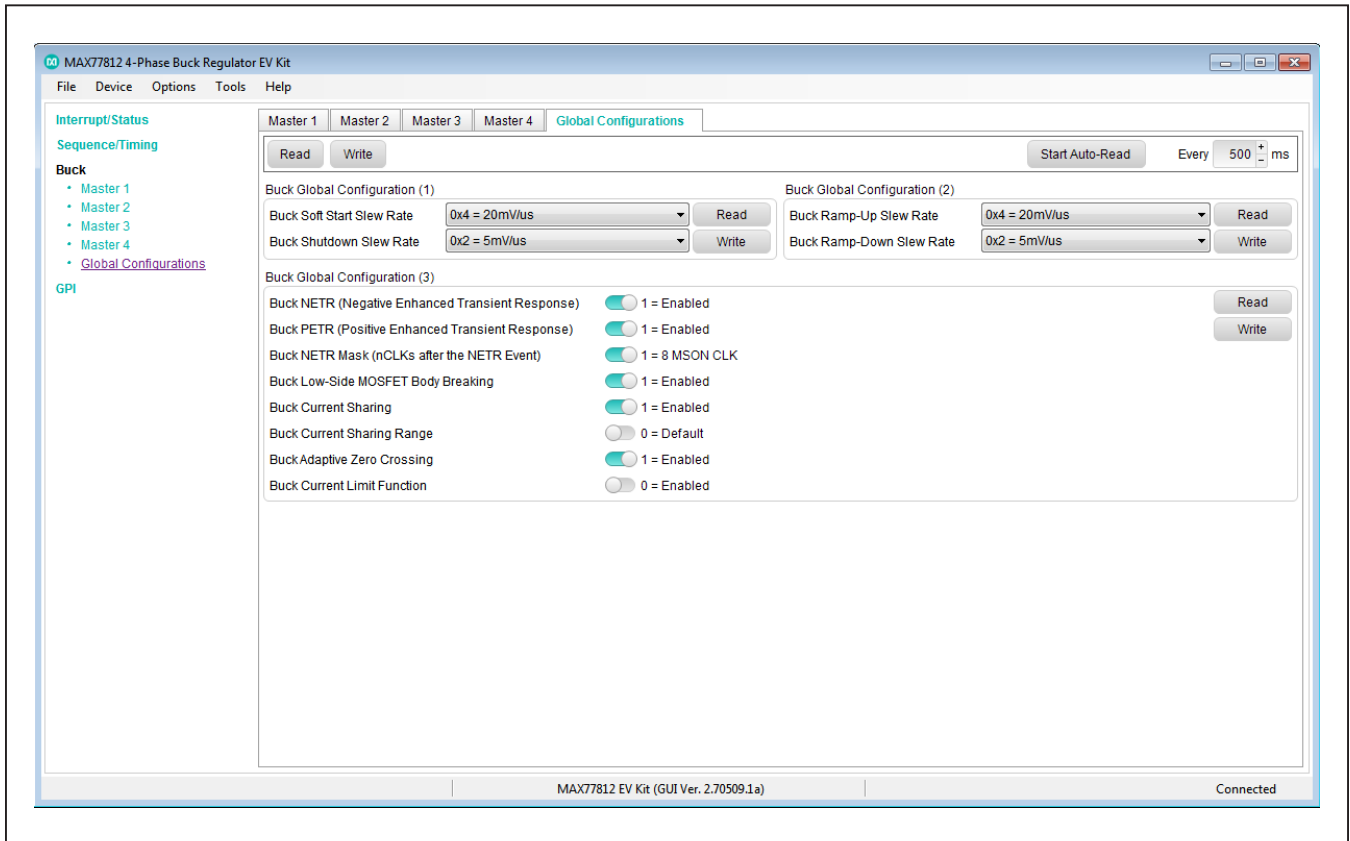

Figure 7. MAX77812 EV Kit Startup/Shutdown Slew Rate, Ramp-Up/Down Slew Rate, ETR, Current Sharing and Limit Function Settings

Phase/Output Configuration Programming

The MAX77812 supports user-programmable phase configurations. All supported phase configurations are shown below:

- 1 Output: 4-phase (Master 1)
- 2 Outputs: 3-phase (Master 1) + 1-phase (Master 4)
- 2 Outputs: 2-phase (Master 1) + 2-phase (Master 3)
- 3 Outputs: 2-phase (Master 1) + 1-phase (Master 3) + 1-phase (Master 4)

- 4 Outputs: 1-phase (Master 1) + 1-phase (Master 2) + 1-phase (Master 3) + 1-phase (Master 4)

The MAX77812 EV kit default setting is 4-phase. See the [Quick Start](#) section and [Table 1](#) for operating the EV kit in 4-phase configuration and its default settings. To program to other phase configurations, [Figure 8](#), [Table 3](#), [Table 4](#), and [Table 5](#) summarize the changes needed in GUI instructions and hardware setup as well as jumper and 0Ω resistor settings. [Table 4](#) also describes the options to select local or remote differential sense for each buck master.

Table 3. Phase/Output Configuration Programming

CONFIGURATION	JU-PH_CFG2/ JU-PH_CFG1/ JU-PH_CFG0 SETTING	GUI OUTPUT VOLTAGES ENABLE SETTING
1 Output: 4 Phase	Low/Low/Low	4 Phase: Buck Master 1 Output 1 = Enabled
2 Outputs: 3 + 1 Phase	Low/Low/High	3 Phase: Buck Master 1 Output 1 = Enabled 1 Phase: Buck Master 4 Output 1 = Enabled
2 Outputs: 2 + 2 Phase	Low/High/Low	2 Phase: Buck Master 1 Output 1 = Enabled 2 Phase: Buck Master 3 Output 1 = Enabled
3 Outputs: 2 + 1 + 1 Phase	Low/High/High	2 Phase: Buck Master 1 Output 1 = Enabled 1 Phase: Buck Master 3 Output 1 = Enabled 1 Phase: Buck Master 4 Output 1 = Enabled
4 Outputs: 1 + 1 + 1 + 1 Phase	High/X/X	1 Phase: Buck Master 1 Output 1 = Enabled 1 Phase: Buck Master 2 Output 1 = Enabled 1 Phase: Buck Master 3 Output 1 = Enabled 1 Phase: Buck Master 4 Output 1 = Enabled

Table 4. Programming Output Options

PHASE CONFIG	TEST LOAD CONNECTION OPTIONS	BUCK OUTPUT CONNECTION								LOCAL SENSE								REMOTE SENSE AT TRANSIENT LOAD										
		R 29	R 30	R 31	R 32	R 33	R 34	R 35	R 36	R 37	R 38	R 39	R 40	R 41	R 42	R 43	R 44	R 45	R 46	R 47	R 48	R 49	R 50	R 51	R 52	R 53	R 54	
4 Phase	1 M1 connects to on-board transient load	X	X	X	X																							
	2 M1 connects to external load at VOUT1/GND12					X	X	X	X																			
3 + 1 Phase	3 M1 connects to on-board transient load M4 connects to external load at VOUT4/GND34	X	X																									
	4 M4 connects to on-board transient load M1 connects to external load				X	X	X	X	X																			
2 + 2 Phase	5 M1 connects to external load at VOUT1/GND12 M4 connects to external load at VOUT4/GND34					X	X	X	X																			
	6 M1 connects to on-board transient load M3 connects to external load at VOUT3/GND34	X	X																									
2 + 2 Phase	7 M3 connects to on-board transient load M1 connects to external load at VOUT1/GND12			X	X	X	X	X	X																			
	8 M1 connects to external load at VOUT1/GND12 M3 connects to external load at VOUT3/GND34					X	X	X	X																			

Table 4. Programming Output Options (continued)

PHASE CONFIG	TEST LOAD CONNECTION OPTIONS	BUCK OUTPUT CONNECTION								LOCAL SENSE								REMOTE SENSE AT TRANSIENT LOAD							
		R 29	R 30	R 31	R 32	R 33	R 34	R 35	R 6	R 7	R 8	R 9	R 4	R 40	R 5	R 41	R 21	R 25	R 22	R 26	R 23	R 27	R 24	R 28	
2+1+1 Phase	9	M1 connects to on-board transient load M3 connects to external load at VOUT3/GND34 M4 connects to external load at VOUT4/GND34	X										X	X	X	X	X	X	X	X	X	X	X		
	10	M3 connects to on-board transient load M1 connects to external load at VOUT1/GND12 M4 connects to external load at VOUT4/GND34		X					X	X	X	X			X	X					X				
	11	M4 connects to on-board transient load M1 connects to external load at VOUT1/GND12 M3 connects to external load at VOUT3/GND34																							X
	12	M1 connects to external load at VOUT1/GND12 M3 connects to external load at VOUT3/GND34 M4 connects to external load at VOUT4/GND34				X							X	X	X	X									

Table 4. Programming Output Options (continued)

Instructions

- 1) R29, R30, R31, R32, R33, R34, and R35 connect the output of the buck regulators when MAX77812 is configured as a 2, 3, or 4-phase regulator. Install these resistors as instructed in [Table 4](#) to avoid unintentional shorting of the buck regulator outputs.
- 2) R6, R8, R7, R9, R4, R40, R5, and R41 connect the differential sense input of the buck regulator to the local sense point at the buck regulator output. R21, R25, R22, R26, R23, R27, R24, and R28 connect the differential sense input to the remote sense point at the on-board transient load. Use either local sense or remote sense but not both at the same time. Connecting the differential sense input to both local and remote sense points at the same time can lead to poorer regulation.
- 3) *Example:* User would like to set up the MAX77812 EV kit to (2+2) phase configuration with the first output

(M1) connected to the on-board transient load and the second output (M3) connected to external load. In this case, option 6 is selected and the 0Ω resistors are installed as instructed in the table:

- R29 and R30 are installed to connect VOUT1 and VOUT2 to form a 2-phase regulator connected to the on-board transient load.
- R35 is installed to connect VOUT3 and VOUT4 to form a 2-phase regulator but does not connect to the on-board transient load. An external load can be connected between VOUT3/VOUT4 and GND34.
- R4, R40, R5, and R41 are installed to connect the differential sense input of M3 and M4 to the local sense points.
- R21, R25, R22, and R26 are installed to connect the differential sense input of M1 and M2 to the remote sense point at the on-board transient load.
- R31, R32, R33, R34, R6, R8, R7, R9, R23, R27, R24, and R28 are not installed.

Table 5. Default Output Voltage and Startup Delay Time

DEFAULT OUTPUT VOLTAGE (V)				STARTUP DELAY TIME (ms)		
M1_VOUT	M2_VOUT	M3_VOUT	M4_VOUT	M2_STUP_DLY	M3_STUP_DLY	M4_STUP_DLY
0.65	0.65	0.60	0.60	0	0	0

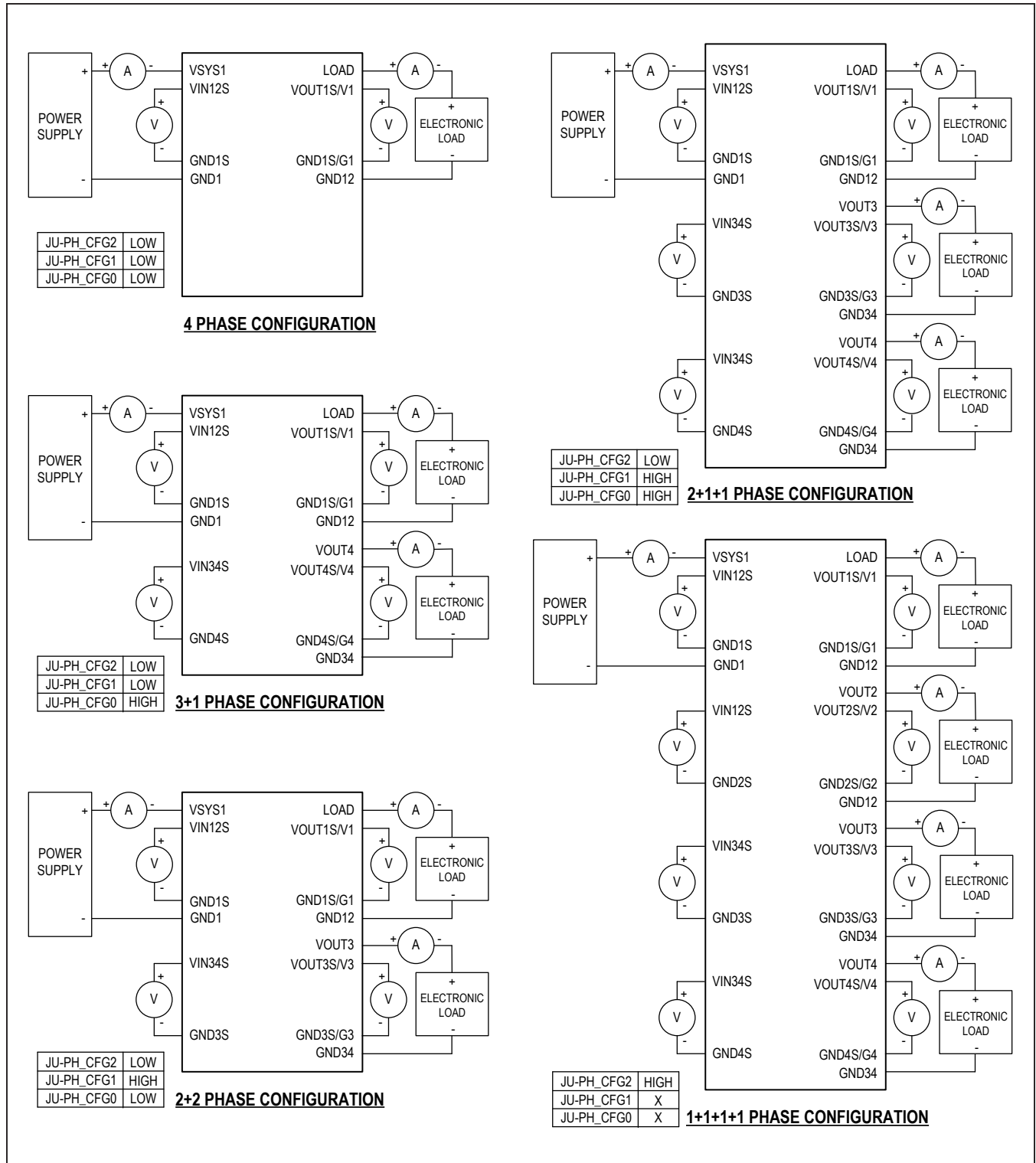

Figure 8. Various Phase Configurations Hardware Setup

Component Suppliers

SUPPLIER	PHONE	WEBSITE
MURATA	770-436-1300	www.murata-northamerica.com
KEYSTONE	718-956-8900	www.keyelco.com
LITE-ON ELECTRONICS; INC.	408-946-4873	www.us.lite-on.com
NXP SEMICONDUCTORS	800-521-6274	www.nxp.com
WEICO WIRE	631-254-2970	www.weicowire.com
FCI CONNECT	800-237-2374	www.fci.com
SAMTEC	800-726-8329	www.semtec.com
SULLINS ELECTRONICS CORP.	888-774-3100	www.sullinscorp.com
TOKO	847-803-6100	www.tokoam.com
FAIRCHILD SEMICONDUCTOR	408-822-2000	www.fairchildsemi.com
VISHAY DALE	402-563-6866	www.vishay.com
YAGEO PHICOMP	408-240-6200	www.yageo.com
BOURNS	951-781-5500	www.bourns.com
PANASONIC	800-344-2112	www.panasonic.com
FUTURE TECHNOLOGY DEVICES	503-547-0988	www.ftdichip.com
HIROSE ELECTRIC CO LTD.	805-522-7958	www.hirose-connector.com
KYOCERA-KINSEKI	864-967-2150	www.global.kyocera.com
TE CONNECTIVITY	800-522-6752	www.te.com
JOHNSON COMPONENTS	507-833-8822	www.cinchconnectivity.com
ALPS ELECTRIC	+81 (3) 5499-8154	www.alps.com

Note: Indicate that you are using the MAX77812 when contacting these component suppliers.

Ordering Information

PART	TYPE
MAX77812EVKIT#	EV Kit

#Denotes RoHS compliant.

MAX77812 EV Kit Bill of Materials

PART	QTY	DESCRIPTION
Minimal Bill of Materials for MAX77812 Single-Output 4-Phase Design		
C1	1	CAPACITOR; SMT 0402; CERAMIC; 1µF; 10V; 10%; X5R MURATA GRM188R61A105KA61
C2, C12, C14-C16	5	CAPACITOR; SMT 0402; CERAMIC; 0.1µF; 10V; 10%; X5R MURATA GRM155R71A104KA01D
C3, C4, C21, C22	4	CAPACITOR; SMT 0603; CERAMIC; 10µF; 6.3V; 5%; X5R MURATA GRM188R60J106ME47J
C5-C8	4	CAPACITOR; SMT 0603; CERAMIC; 22µF; 6.3V; 20%; X5R MURATA GRM188C80J226ME15D
L1-L4	4	INDUCTOR; SMT 2520; 0.22µH; ±20%; 7A ALPS GLULMR2201A
R1, R2	2	RESISTOR, 0402, 1.5kΩ, 1%, 100PPM, 0.0625W, THICK FILM VISHAY CRCW04021K50FK
R3	1	RESISTOR, 0402, 100kΩ, 1%, 100PPM, 0.0625W, THICK FILM VISHAY CRCW0402100KFK; YAGEO PHICOMP RC0402FR-0700KL
U1	1	IC; MAX77812EWB+T; 64 BUMPS WLP PKG. 0.40mm PITCH MAXIM MAX77812EWB+T
Other Components for Evaluation Kit		
C9, C11, C17-C20, C23, C24, C29, C32, C38, C139	0	NOT INSTALLED: CAPACITOR; SMT 0603
C10	0	NOT INSTALLED: CAPACITOR; SMT 0805
C13	1	CAPACITOR; SMT 3528; TANTALUM; 100µF; 6.3V; 20% AVX TCJB107M006R0070
C25-C27, C33-C37	8	CAPACITOR; SMT 0402; CERAMIC; 4.3µF; 4V; 20%; X5R MURATA LLD154R60G435ME01
C39	0	NOT INSTALLED: CAPACITOR; SMT 1206
C40-C42	3	CAPACITOR; SMT 0603; CERAMIC; 10µF; 16V; 20%; X5R MURATA GRM188R61C106MA73D
C108, C116, C117, C138, C150, C151, C155-C157, C159	10	CAPACITOR; SMT 0402; CERAMIC; 0.1µF; 25V; 10%; X7R TDK C100 5X7R1E104K050BB
C110-C113, C115, C118, C137, C158	8	CAPACITOR; SMT 0402; CERAMIC; 1µF; 6.3V; 10%; X5R MURATA GRM155R60J105KE19D
C114	1	CAPACITOR; SMT; 0603; CERAMIC; 0.47µF; 10V; 10% KEMET C0603C474K8PAC
C120	1	CAPACITOR; SMT 0402; CERAMIC; 1µF; 6.3V; 20%; X5R TDK C1005X5R01105M050BB
C152, C153	2	CAPACITOR; SMT; 0402; CERAMIC; 8.2pF; 50V; 0.25% KEMET C0402C829C5GAC
C154	1	CAPACITOR; SMT 0603; CERAMIC; 4.7µF; 16V; 10%; X5R TDK C1608X5R1C475K080AC
D100, D101	2	DIODE; LED; STANDARD; YELLOW; SMT 0603; PIV=5.0V; IF=0.02A LITE-ON LTST-C190YKT
D102, D103	2	DIODE; LED; STANDARD; RED; SMT 0603; PIV=5.0V; IF=0.04A LITE-ON LTST-C190CKT
FB100	1	INDUCTOR; SMT 0603; FERRITE-BEAD; 220Ω; +/-25%; 1.4A MURATA BLM18PG221SN1
J1	1	CONNECTOR; FEMALE; SMT; MICRO USB B-TYPE REVERSE; 5PINS FCI CONNECT 10103592-0001LF
J2, J101, JU-CE, JU-EN, JU-GPI0, JU-GPI1, JU-I2C_SPI_SEL, JU-LPM, JU-PH_CFG0-JU-PH_CFG2	11	CONNECTOR; THROUGH HOLE; SINGLE ROW; STRAIGHT; 3PINS SAMTEC TSW-103-07-L-S
J3	0	NOT INSTALLED: CONNECTOR; FEMALE THREADED; THROUGH HOLE; SMA; 5PINS JOHNSON COMPONENTS 142-0701-231

MAX77812 EV Kit Bill of Materials (continued)

PART	QTY	DESCRIPTION
J4-J6	3	CONNECTOR; MALE; THROUGH HOLE; STRAIGHT; 2PINS SULLINS PBC02SAAN
J100	0	CONNECTOR; MALE; THROUGH HOLE; STRAIGHT; 10PINS TE CONNECTIVITY 2-1761603-3
JU-SCL, JU-SDA, JU-VIO	3	CONNECTOR; THROUGH HOLE; 2PINS SAMTEC TSW-102-07-T-S
Q1	1	TRAN; HEXFET POWER MOSFET; NCH; SO-8; PD-(2.5W); I-(18A); V-(30V) INTERNATIONAL RECTIFIER IRF8736PBF
Q102	1	TRAN; DUAL N-CHANNEL 2.5V SPECIFIED POWERTRENCH MOSFET; NCH; SOT563-6; PD-(0.625W); I-(0.6A); V-(20V) FAIRCHILD FDY3000NZ
R4-R9, R40, R41	0	NOT INSTALLED: RESISTOR; 0603; 0Ω VISHAY CRCW06030000Z0EA
R10	1	RESISTOR; 0402; 10kΩ; 1%; 100PPM; 0.125W; THICK FILM VISHAY CRCW080510K0FK; ROHM MCR10EZHF1002; PANASONIC ERJ- GENF1002V; YAGEO RC0805FR-0710KL
R14	1	RESISTOR; 0603; 0Ω; 5%; JUMPER; 0.10W; THICK FILM SAMSUNG RC1608J000CS; BOURNS CR0603-J/-000ELF; YAGEO RC0603JR-070RL
R15	1	RESISTOR, 0603, 500Ω, 1%, 100PPM, 0.10W, THICK FILM VISHAY CRCW0603500RFB
R16	1	RESISTOR; THROUGH HOLE-RADIAL LEAD; 100Ω; 5%; 10PPM; 0.25W; METAL FOIL VISHAY FOIL RESISTOR Y4053100R000J0
R17	1	RESISTOR; THROUGH HOLE-RADIAL LEAD; 1kΩ; 5%; 10PPM; 0.25W; METAL FOIL VISHAY FOIL RESISTOR Y40531K00000J0
R18, R132, R135	0	NOT INSTALLED: RESISTOR; 0402
R19, R20	2	RESISTOR; 2512; 0.01Ω; 1%; 75PPM; 3.0W; THICK FILM BOURNS CRA2512-FZ-R010ELF
R21-R28, R102	9	RESISTOR; 0603; 0Ω; 0%; JUMPER; 0.10W; THICK FILM VISHAY CRCW06030000Z0EA
R29-R32	4	RESISTOR; 2512; 0Ω; 1%; JUMPER; 1.0W; METAL FILM VISHAY CRCW25120000ZS
R33-R35	0	NOT INSTALLED: RESISTOR; 2512; 0Ω; 1%; JUMPER; 1.0W; METAL FILM VISHAY CRCW25120000ZS
R103	1	RESISTOR; 0603; 1MΩ; 1%; 100PPM; 0.10W; THICK FILM YAGEO RC0402FR-071ML
R104, R105	2	RESISTOR, 0402, 22Ω, 1%, 100PPM, 0.0625W, THICK FILM YAGEO RC0402FR-0722R
R107, R108, R112-R118, R133, R134, R136-R147	23	RESISTOR; 0402; 0Ω; 0%; JUMPER; 0.10W; THICK FILM VISHAY CRCW04020000ZS
R109, R110	2	RESISTOR, 0402, 4.7kΩ, 1%, 100PPM, 0.0625W, THICK FILM VISHAY CRCW04024K70FK
R111, R131	2	RESISTOR, 0402, 470Ω, 1%, 100PPM, 0.0625W, THICK FILM VISHAY CRCW0402470RFB
R119	1	RESISTOR; 0402; 1MΩ; 1%; 100PPM; 0.10W; THICK FILM PANASONIC ERJ-2RKF1004
R120	1	RESISTOR, 0402, 100kΩ, 1%, 100PPM, 0.0625W, THICK FILM VISHAY CRCW0402100KFK; YAGEO PHICOMP RC0402FR-0700KL
R121	1	RESISTOR; 0402; 10kΩ; 1%; 100PPM; 0.0625W; THICK FILM VISHAY DALE CRCW040210K0FK; YAGEO PHICOMP RC0402FR-0710K
R129, R130	2	RESISTOR; 0402; 100Ω; 1%; 100PPM; 0.063W; THICK FILM VISHAY DALE CRCW0402100RFB; PANASONIC 9C04021A1000FL; YAGEO PHICOMP RC0402FR-07100RL

MAX77812 EV Kit Bill of Materials (continued)

PART	QTY	DESCRIPTION
SW1	1	SWITCH; SPST; SMT; 15V; 0.02A; LIGHT TOUCH SWITCH PANASONIC EVQ-Q2K03W
U2	1	IC; AMP; 1.1A; 35MHz CURRENT FEEDBACK AMPLIFIER; NSOIC16 LINEAR TECHNOLOGY LT1210CS#PBF
U100	1	IC; CTRL; LOW-POWER LCD MICROCONTROLLER; TQFN56-EP 8X8 MAXIM MAXQ2000-RBX+
U101	1	IC; INFC; UART INTERFACE IC USB TO SERIAL; QFN32-EP 5X5 FUTURE TECHNOLOGY FT232RQ
U102	1	IC; VREG; ULTRA-LOW-NOISE, HIGH PSRR, LOW-DROPOUT, LINEAR REGULATOR; SC70-5 MAXIM MAX8511EXK33+
U103	1	IC; VREG; ULTRA-LOW-NOISE; HIGH PSRR; LOW-DROPOUT; LINEAR REGULATOR; SC70-5 MAXIM MAX8511EXK18+
U104	1	IC; VREG; ULTRA-LOW-NOISE HIGH PSRR LOW-DROPOUT LINEAR REGULATOR; SC70-5 MAXIM MAX8511EXK25+
U105	1	HIGH-/FULL-SPEED USB 2.0 SWITCH, DUALSPDT MAXIM MAX4906ELB+
U107	1	IC; TRANS; 15kV ESD-PROTECTED HIGH-DRIVE CURRENT QUAD LEVEL TRANSLATOR WITH SPEED-UP CIRCUITRY; TQFN12 4X4 MAXIM MAX3395EETC
U108	1	IC; TRANS; QUAD-LEVEL TRANSLATOR; TSSOP14 MAXIM MAX3023EUD
VO1S-VO4S	4	CONNECTOR; MALE; SMT; ULTRA SMALL SURFACE MOUNT COAXIAL CONNECTOR; STRAIGHT; 2PINS HIROSE ELECTRIC U.FL-R-SMT-1
Y101	1	CRYSTAL; SMT 3225 3.2X2.5; 8PF; 16MHz; +/-10PPM; +/-15PPM KYOCERA-KINSEKI CX3225SB16000D0FLJZZ
LOAD, LOAD1	2	MAXIM PAD
CE, EN, GPIO, GPI1, IRQB, I2CSPSEL, LPM, MISO, PH_CFG0- PH_CFG2, SCL, SCS, SDA-MOSI, WDTRSTB_IN	15	TEST POINT; PIN DIA=0.1IN; TOTAL LENGTH=0.3IN KEYSTONE 5002
GND1-GND6, GND12, GND12A, GND34, GND34A, VOUT1-VOUT4, VOUT1A-VOUT4A, VSYS1, VSYS2	20	MAXIM PAD; WIRE; 20AWG WEICO 9020 BUSS
G1-G4, V1-V4, GND1S-GND4S, VIN12S, VIN34S, VOUT1S-VOUT4S	18	TEST POINT; PIN DIA=0.1IN; TOTAL LENGTH=0.3IN KEYSTONE 5000
V+, V-, CS+, CS-, VIO, GATE	6	TESTPOINT; MULTIPURPOSE KEYSTONE 5010
PCB	1	PCB; MAX77812 EVKIT

MAX77812 EV Kit Schematics (continued)

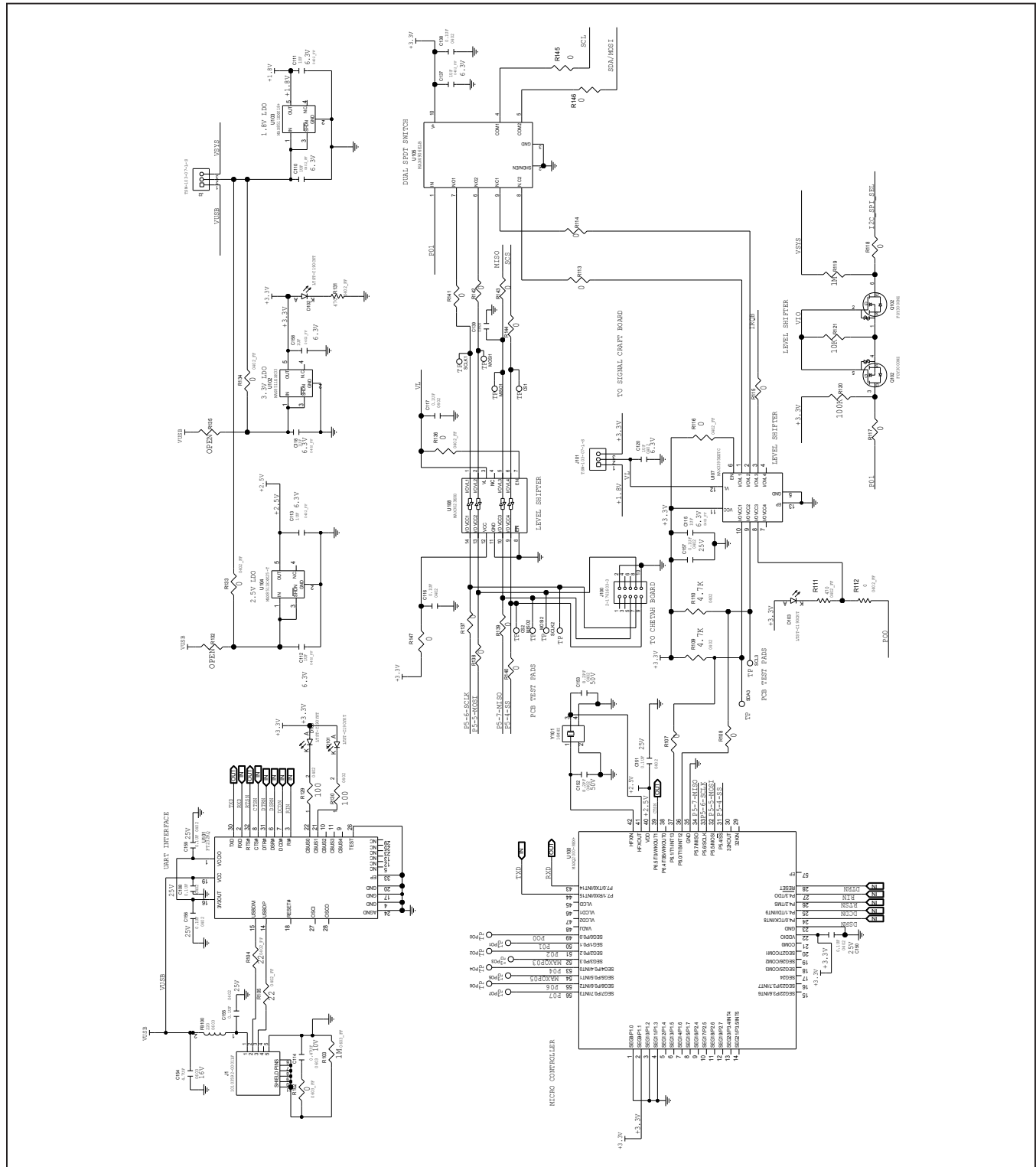

MAX77812 EV Kit PCB Layouts

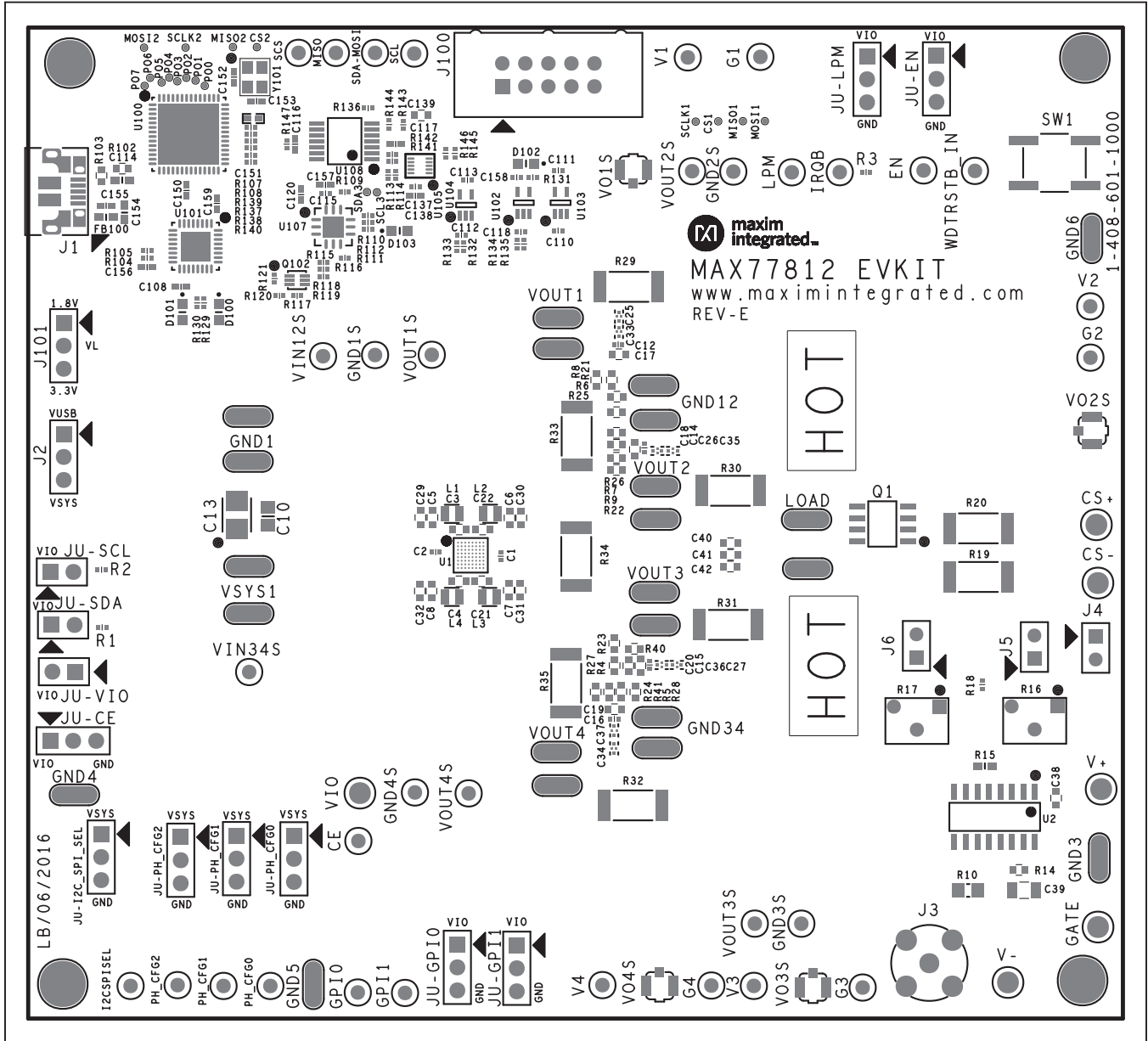

MAX77812 EV Kit Component Placement Guide—Top Silkscreen

MAX77812 EV Kit PCB Layouts (continued)

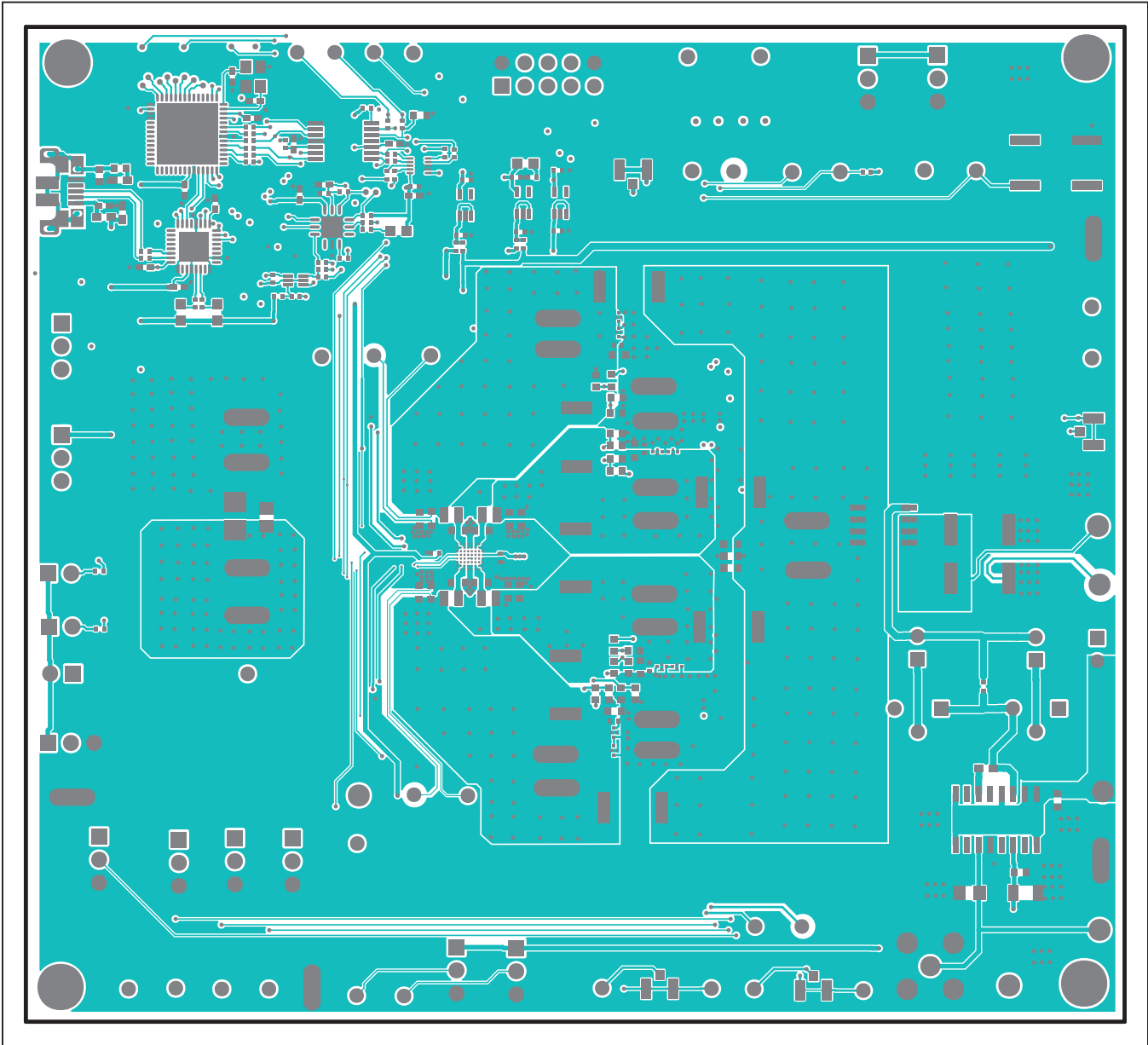

MAX77812 EV Kit PCB Layout—Top Layer

MAX77812 EV Kit PCB Layouts (continued)

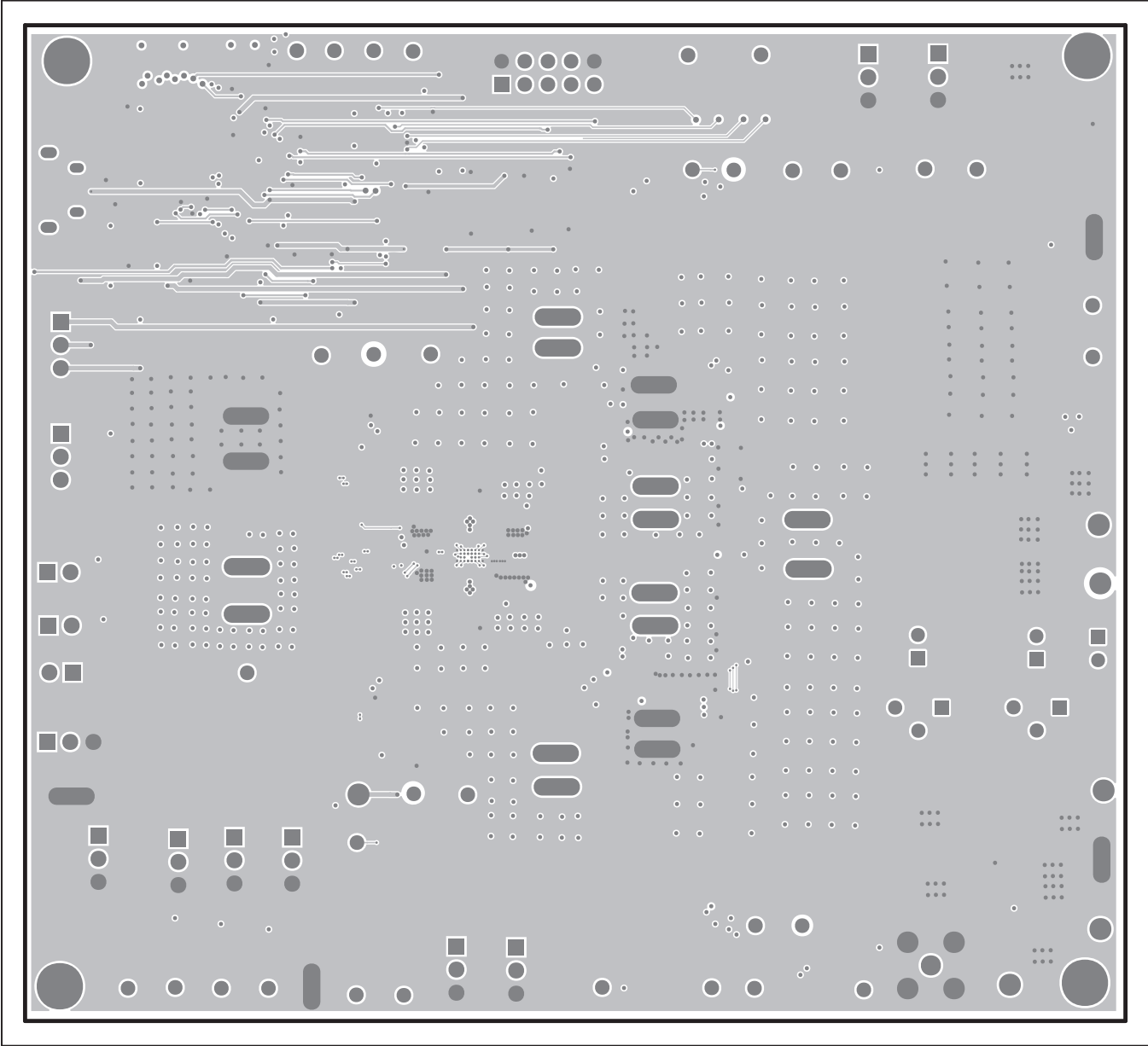

MAX77812 EV Kit PCB Layout—Internal Layer 2

MAX77812 EV Kit PCB Layouts (continued)

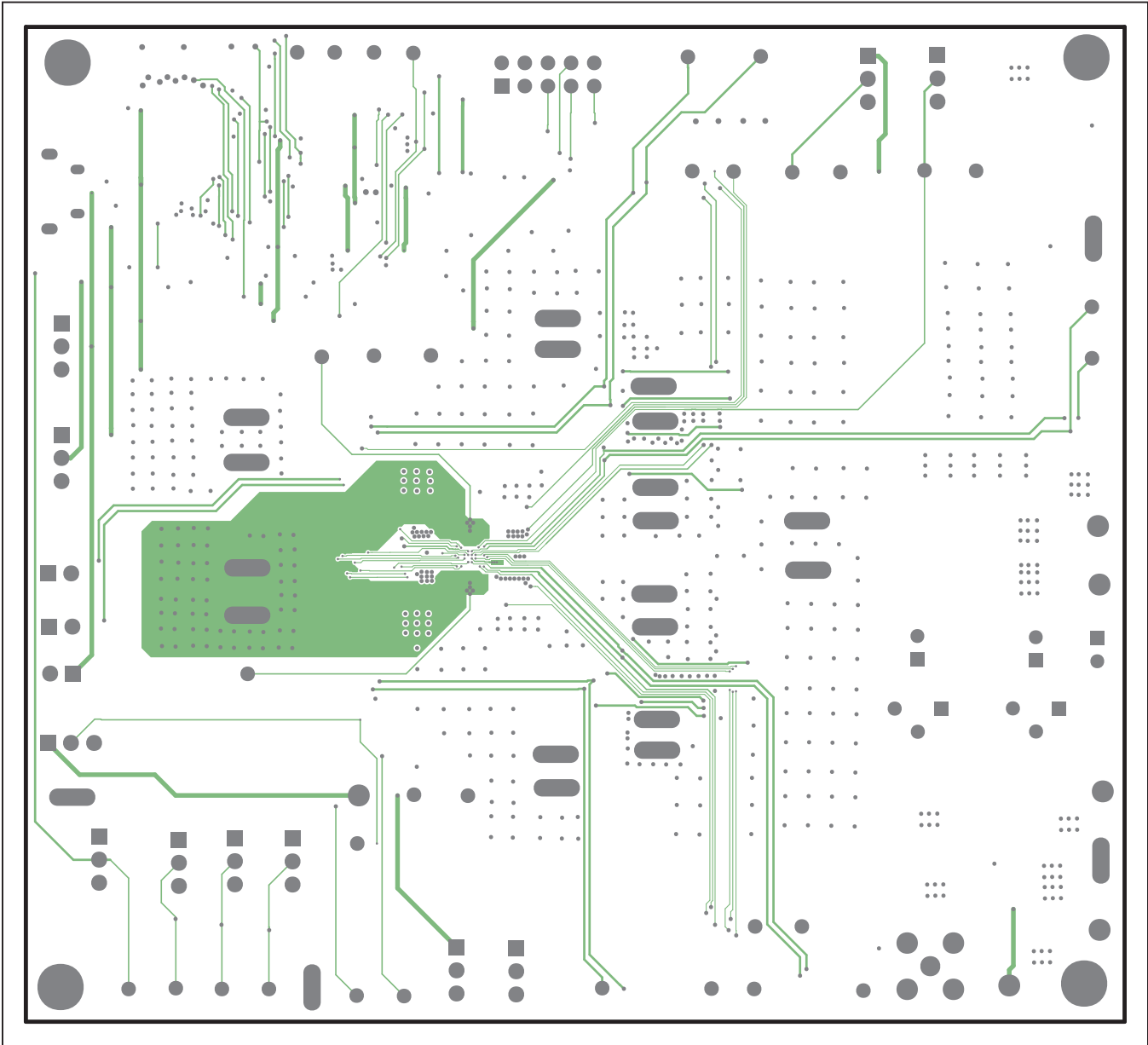

MAX77812 EV Kit PCB Layout—Internal Layer 3

MAX77812 EV Kit PCB Layouts (continued)

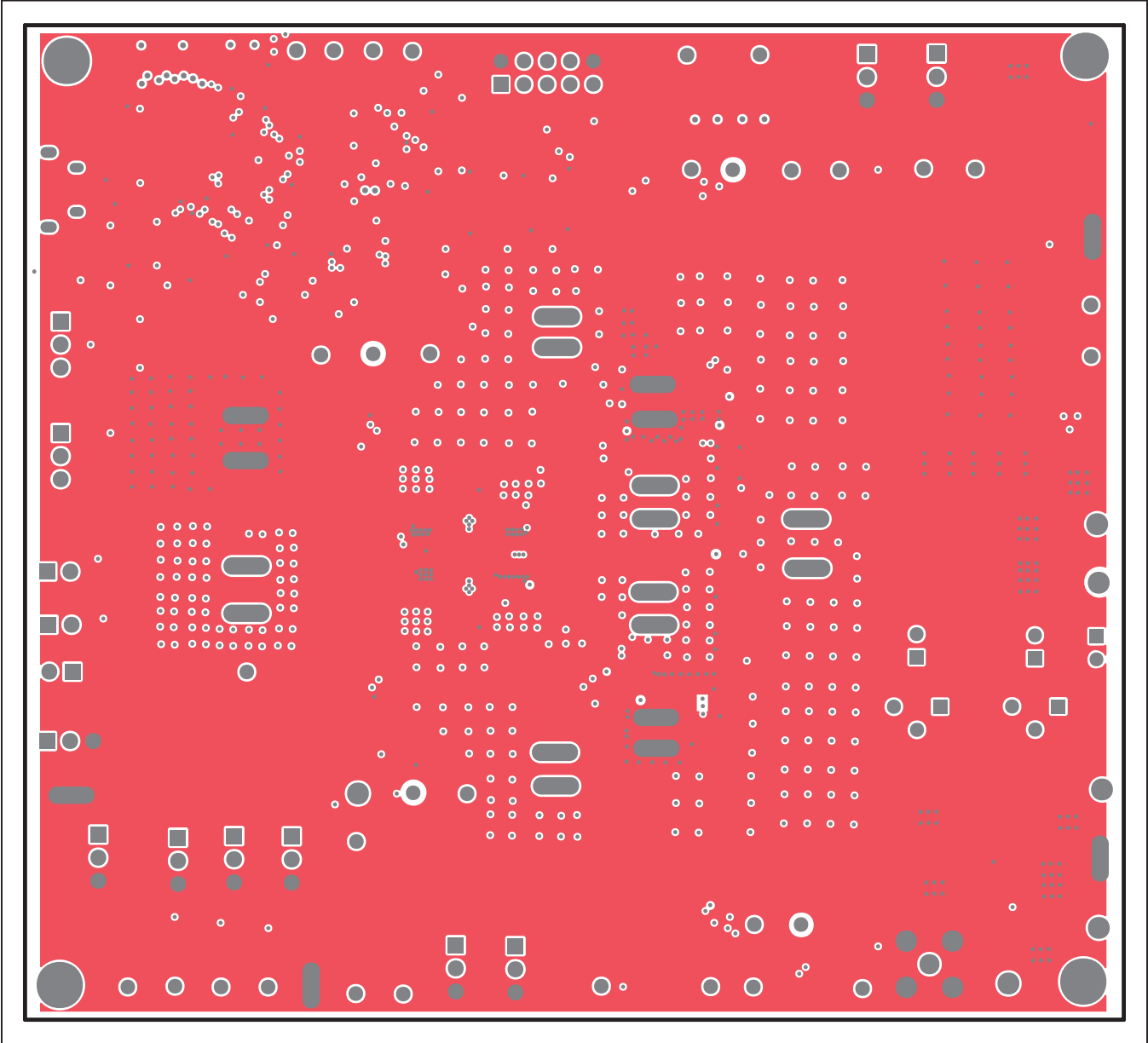

MAX77812 EV Kit PCB Layout—Internal Layer 4

MAX77812 EV Kit PCB Layouts (continued)

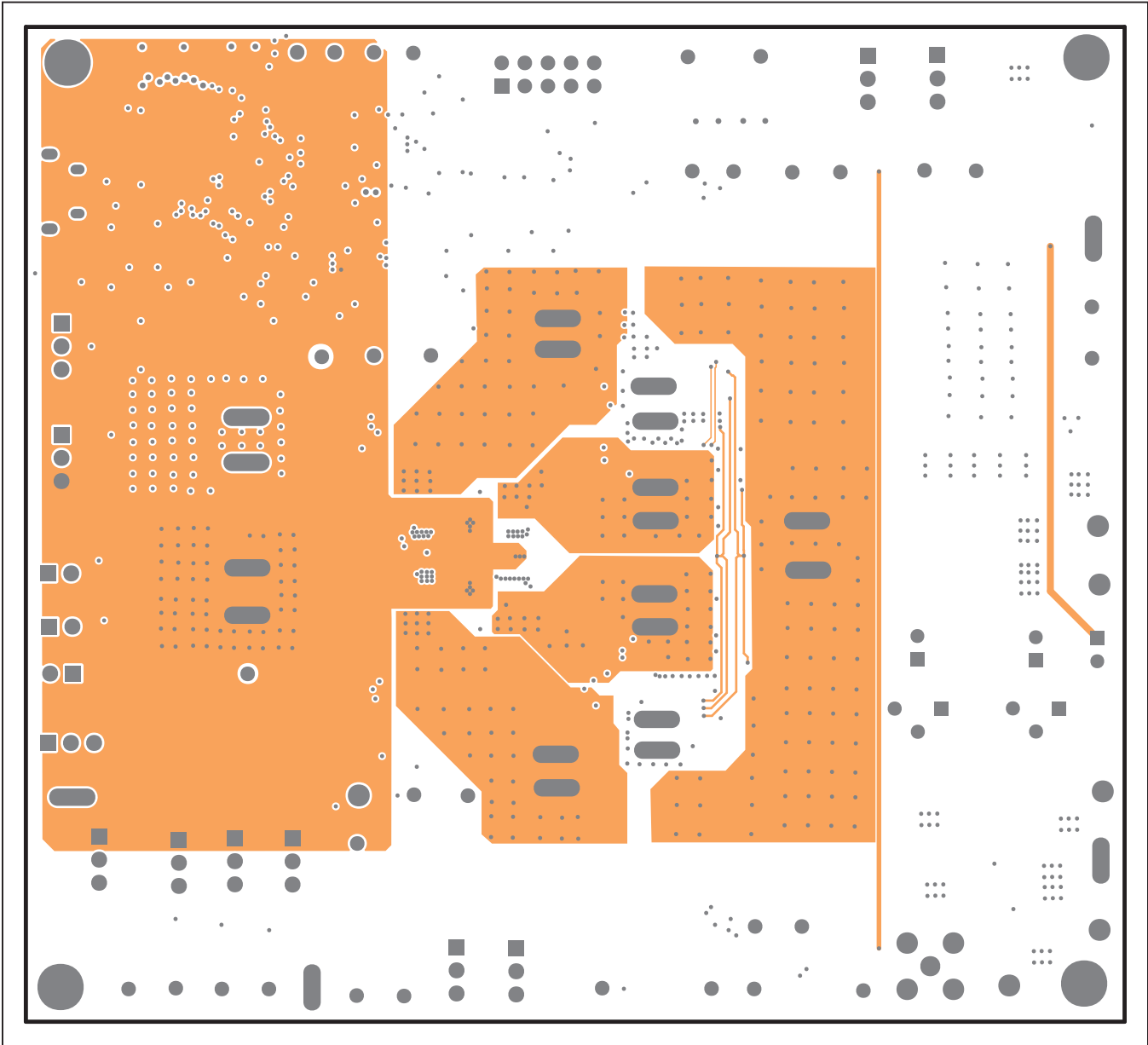

MAX77812 EV Kit PCB Layout—Internal Layer 5

MAX77812 EV Kit PCB Layouts (continued)

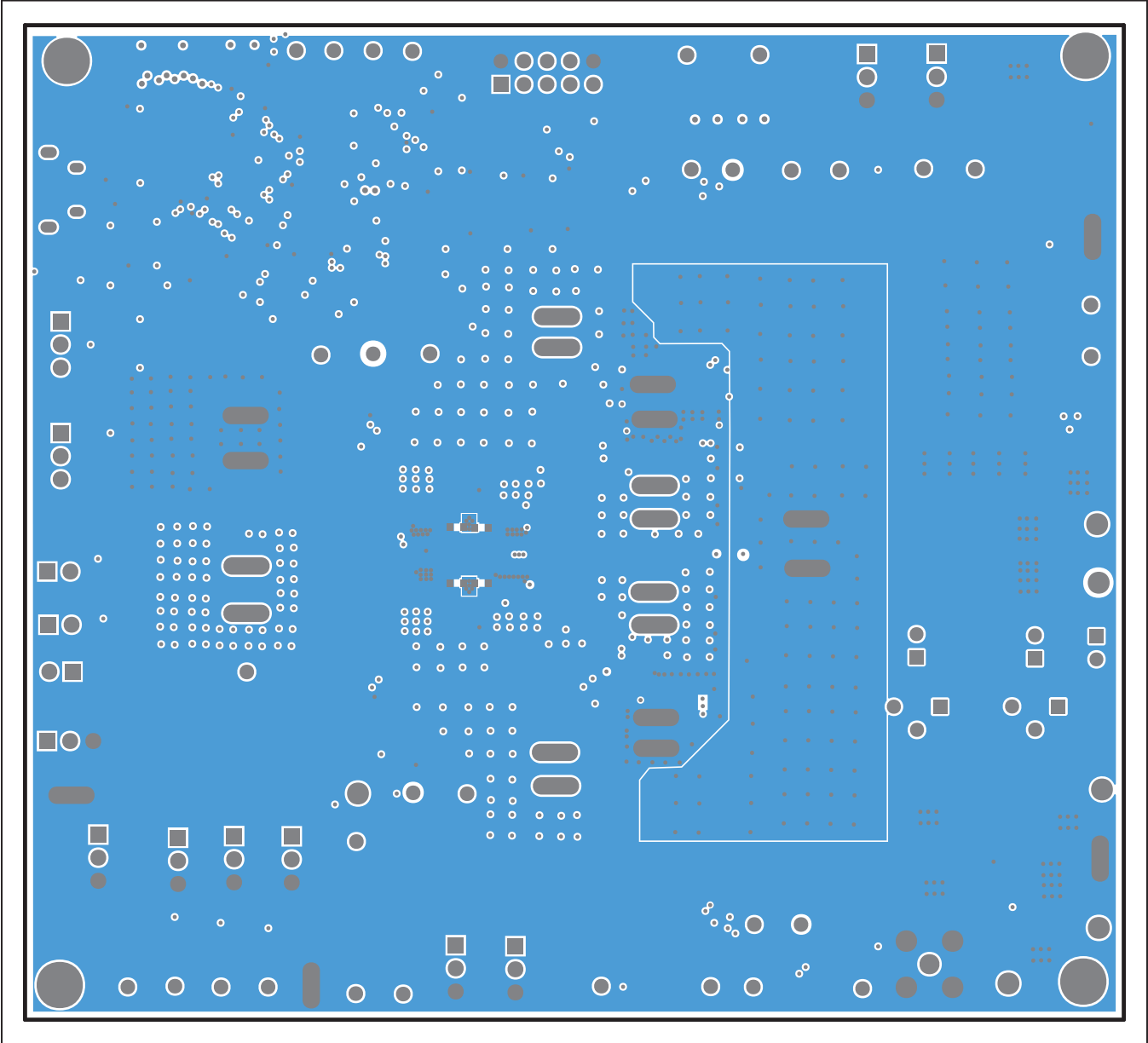

MAX77812 EV Kit PCB Layout—Bottom Layer

Revision History

REVISION NUMBER	REVISION DATE	DESCRIPTION	PAGES CHANGED
0	6/16	Initial release	—
1	7/16	Updated Figure 1, Figure 2, Table 1, Table 2, <i>Load Transient Testing</i> section, <i>Phase Configuration Programming</i> section, Table 3, Bill of Materials, Schematics, PCB Layouts, and added Table 4	1, 2, 6, 7, 9, 12–24
2	4/17	Updated Figures 1–8, Table 2, Schematics, PCB Layouts, Bill of Materials, and text in <i>Features</i> and <i>Quick Start</i> sections	1–13, 15–24
3	5/17	Updated Figures 2–8, Table 1, Table 2, Bill of Materials, and text in <i>Features</i> and <i>Quick Start</i> sections	1–7, 9, 11–13
4	12/17	Updated <i>Features</i> section, Figure 1, Figure 2, <i>Component Suppliers</i> table, and <i>MAX77812 EV Kit Bill of Materials</i> table	1, 2, 10, 11
5	7/18	Updated <i>Features</i> section, Figure 1, Figure 2, <i>Phase/Output Configuration Programming</i> section, Table 4, and <i>MAX77812 EV Kit Bill of Materials</i> table	1, 2, 6, 8, 11–13
6	2/19	Updated part number in <i>MAX77812 EV Kit Bill of Materials</i> table from MAX77812 to MAX77812EWB+T	16, 17
7	3/19	Added <i>Default Configurations</i> section and Table 5, updated <i>Phase/Output Configuration Programming</i> section and <i>MAX77812 EV Kit Bill of Materials</i> table	2, 8, 12, 15–17
8	5/23	Updated <i>General Description</i> section	1



Information furnished by Analog Devices is believed to be accurate and reliable. However, no responsibility is assumed by Analog Devices for its use, nor for any infringements of patents or other rights of third parties that may result from its use. Specifications subject to change without notice. No license is granted by implication or otherwise under any patent or patent rights of Analog Devices. Trademarks and registered trademarks are the property of their respective owners.

Looking for pricing, stock, or lifecycle information?

Click below to explore more details on WIN SOURCE:

- ⊖ [View MAX77812EVKIT# on WIN SOURCE](#)
- ⊖ [Maxim Integrated Information](#)

Optimize Your Supply Chain with WIN SOURCE Solutions

- ✓ Global Sourcing Solution
- ✓ Obsolete Management
- ✓ Cost Control Management
- ✓ Shortage Management
- ✓ Alternative Solution
- ✓ Excess Inventory Management