

Click [here](#) to ask about the production status of specific part numbers.

MAX14934–MAX14936

Four-Channel, 5kV_{RMS} Digital Isolators

General Description

The MAX14934–MAX14936 are a family of four-channel, 5kV_{RMS} digital isolators utilizing Maxim's proprietary process technology. For applications requiring 2.75kV_{RMS} of isolation, see the MAX14930–MAX14932. The MAX14934–MAX14936 family transfers digital signals between circuits with different power domains at ambient temperatures up to +125°C.

The MAX14934–MAX14936 family offers all three possible unidirectional channel configurations to accommodate any four-channel design, including SPI, RS-232, RS-485, and large digital IO modules. For applications requiring bidirectional channels, such as I²C, refer to the MAX14937.

Devices are available with data rates from DC up to 1Mbps, 25Mbps, or 150Mbps. Each device is also available in either a default high or default low configuration. The default is the state an output goes to when its input is unpowered. See the [Product Selector Guide](#) and [Ordering Information](#) for the suffixes associated with each option.

Independent 1.71V to 5.5V supplies on each side of the isolator also make the devices suitable for use as level translators.

The MAX14934–MAX14936 are available in a 16-pin wide body (10.3mm x 7.5mm) SOIC package. All devices are rated for operation at ambient temperatures of -40°C to +125°C.

[Product Selector Guide](#) and [Ordering Information](#) appear at end of data sheet.

Benefits and Features

- Robust Galvanic Isolation of Digital Signals
 - Withstands 5kV_{RMS} for 60s (V_{ISO})
 - Continuously Withstands 848V_{RMS} (V_{IOWM})
 - 1200V_P Repetitive Peak Voltage (V_{IORM})
 - Withstands ±10kV Surge per IEC 61000-4-5
- Interfaces Directly with Most Micros and FPGAs
 - Accepts 1.71V to 5.5V Supplies
- Many Options Support Broad Applications
 - 3 Data Rates (1Mbps, 25Mbps, 150Mbps)
 - 3 Channel Direction Configuration
 - 2 Output Default States (High or Low)
- Low Power Consumption at High Data Rates At 1.8V:
 - 2.5mA per Channel Typical at 1Mbps
 - 5.25mA per Channel Typical at 100Mbps
 At 3.3V:
 - 2.6mA per Channel Typical at 1Mbps
 - 7.1mA per Channel Typical at 100Mbps

Safety Regulatory Approvals

(see [Safety Regulatory Approvals](#))

- UL According to UL1577
- cUL According to CSA Bulletin 5A
- VDE 0884-11 Basic Insulation

Applications

- Fieldbus Communications for Industrial Automation
- Isolated SPI, RS-232, RS-485/RS-422
- General Multichannel Isolation Applications
- Battery Management
- Medical Systems

Functional Diagram

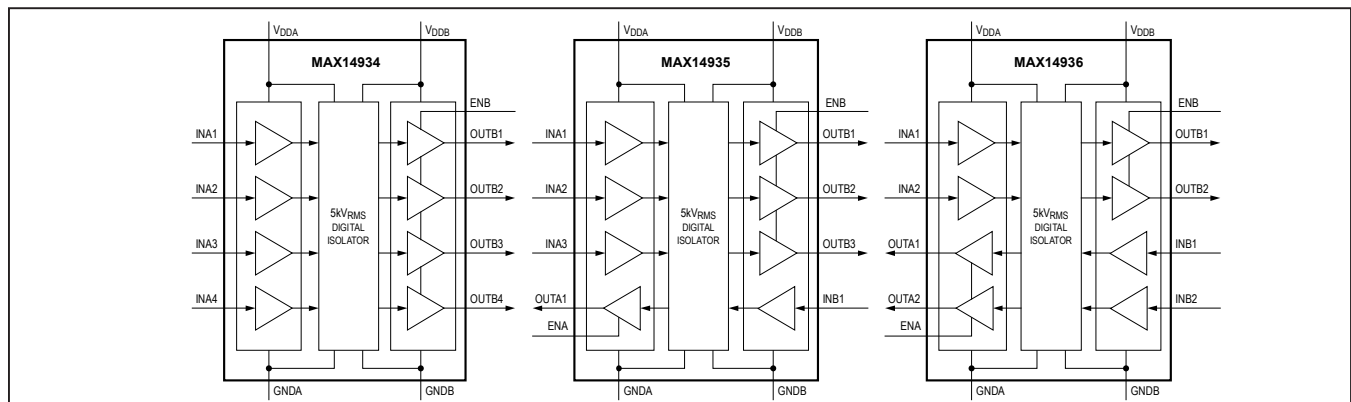

Absolute Maximum Ratings

V _{DDA} to GNDA, V _{DDB} to GNDB	-0.3V to +6V	Continuous Power Dissipation (T _A = +70°C)
INA ₋ , ENA to GNDA	-0.3V to +6V	Wide SOIC (derate 14.1mW/°C above +70°C)
INB ₋ , ENB to GNDB	-0.3V to +6V	Operating Temperature Range
OUTA ₋ to GNDA	-0.3V to (V _{DDA} + 0.3V)	Maximum Junction Temperature
OUTB ₋ to GNDB	-0.3V to (V _{DDB} + 0.3V)	Storage Temperature Range
Short-Circuit Duration		Lead Temperature (soldering, 10s)
(OUTA ₋ to GNDA, OUTB ₋ to GNDB)	Continuous	Soldering Temperature (reflow)

Stresses beyond those listed under "Absolute Maximum Ratings" may cause permanent damage to the device. These are stress ratings only, and functional operation of the device at these or any other conditions beyond those indicated in the operational sections of the specifications is not implied. Exposure to absolute maximum rating conditions for extended periods may affect device reliability.

Package Information

PACKAGE TYPE: 16 Wide SOIC	
Package Code	W16M+8
Outline Number	21-0042
Land Pattern Number	90-0107
THERMAL RESISTANCE, FOUR-LAYER BOARD	
Junction to Ambient (θ _{JA})	71°C/W
Junction to Case (θ _{JC})	23°C/W

Package thermal resistances were obtained using the method described in JEDEC specification JESD51-7, using a four-layer board. For detailed information on package thermal considerations, refer to www.maximintegrated.com/thermal-tutorial.

For the latest package outline information and land patterns (footprints), go to www.maximintegrated.com/packages. Note that a "+", "#", or "-" in the package code indicates RoHS status only. Package drawings may show a different suffix character, but the drawing pertains to the package regardless of RoHS status.

DC Electrical Characteristics

(V_{DDA} - V_{GNDA} = +1.71V to +5.5V, V_{DDB} - V_{GNDB} = +1.71V to +5.5V, C_L = 15pF, T_A = -40°C to +125°C, unless otherwise noted. Typical values are at V_{DDA} - V_{GNDA} = +3.3V, V_{DDB} - V_{GNDB} = +3.3V, V_{GNDA} = V_{GNDB}, T_A = +25°C, unless otherwise noted.) (Note 1)

PARAMETER	SYMBOL	CONDITIONS		MIN	TYP	MAX	UNITS
POWER SUPPLY							
Operating Supply Voltage	V _{DDA}	Relative to GNDA		1.71		5.5	V
	V _{DDB}	Relative to GNDB		1.71		5.5	V
Undervoltage Lockout Threshold	V _{UVLO_}	V _{DD_} rising		1.45	1.58	1.71	V
Undervoltage Lockout Threshold Hysteresis	V _{UVLO_} HYST				50		mV
Supply Current (MAX14934_)	I _{DDA}	500kHz square wave	V _{DDA} = 5V		1.2	1.9	mA
			V _{DDA} = 3.3V		1.2	1.9	
			V _{DDA} = 2.5V		1.2	1.9	
			V _{DDA} = 1.8V		1.1	1.9	
		12.5MHz square wave (Note 2)	V _{DDA} = 5V		2.1	2.7	
			V _{DDA} = 3.3V		2	2.7	
			V _{DDA} = 2.5V		2	2.7	
			V _{DDA} = 1.8V		2	2.6	
		50MHz square wave (Note 2)	V _{DDA} = 5V		5	6.6	
			V _{DDA} = 3.3V		4.6	6.1	
			V _{DDA} = 2.5V		4.5	6.0	
			V _{DDA} = 1.8V		4.5	6.0	
	I _{DDB}	500kHz square wave	V _{DDB} = 5V		8.1	11.2	
			V _{DDB} = 3.3V		7.9	11.1	
			V _{DDB} = 2.5V		7.9	11.0	
			V _{DDB} = 1.8V		7.7	10.8	
		12.5MHz square wave (Note 2)	V _{DDB} = 5V		12.8	15.9	
			V _{DDB} = 3.3V		11.1	14.2	
			V _{DDB} = 2.5V		10.2	13.4	
			V _{DDB} = 1.8V		9.4	12.4	
		50MHz square wave (Note 2)	V _{DDB} = 5V		27.2	35.4	
			V _{DDB} = 3.3V		21.7	27.8	
			V _{DDB} = 2.5V		17.6	23.0	
			V _{DDB} = 1.8V		14.4	18.9	

DC Electrical Characteristics (continued)

(V_{DDA} - V_{GNDA} = +1.71V to +5.5V, V_{DDB} - V_{GNDB} = +1.71V to +5.5V, C_L = 15pF, T_A = -40°C to +125°C, unless otherwise noted. Typical values are at V_{DDA} - V_{GNDA} = +3.3V, V_{DDB} - V_{GNDB} = +3.3V, V_{GNDA} = V_{GNDB}, T_A = +25°C, unless otherwise noted.) (Note 1)

PARAMETER	SYMBOL	CONDITIONS	MIN	TYP	MAX	UNITS
Supply Current (MAX14935_)	I _{DDA}	500kHz square wave	V _{DDA} = 5V	3.4	5.3	mA
			V _{DDA} = 3.3V	3.3	5.3	
			V _{DDA} = 2.5V	3.3	5.3	
			V _{DDA} = 1.8V	3.2	5.1	
		12.5MHz square wave (Note 2)	V _{DDA} = 5V	5.6	7.1	
			V _{DDA} = 3.3V	5	6.6	
			V _{DDA} = 2.5V	4.7	6.4	
			V _{DDA} = 1.8V	4.5	6.1	
		50MHz square wave (Note 2)	V _{DDA} = 5V	12.4	16.0	
			V _{DDA} = 3.3V	10.1	13.0	
			V _{DDA} = 2.5V	9.1	11.6	
			V _{DDA} = 1.8V	8.2	10.4	
	I _{DDB}	500kHz square wave	V _{DDB} = 5V	6.5	9.2	
			V _{DDB} = 3.3V	6.4	9.1	
			V _{DDB} = 2.5V	6.3	9.1	
			V _{DDB} = 1.8V	6.2	8.9	
		12.5MHz square wave (Note 2)	V _{DDB} = 5V	10.3	12.8	
			V _{DDB} = 3.3V	8.9	11.6	
			V _{DDB} = 2.5V	8.2	11.0	
			V _{DDB} = 1.8V	7.6	10.3	
		50MHz square wave (Note 2)	V _{DDB} = 5V	22.7	29.1	
			V _{DDB} = 3.3V	17.7	23.0	
			V _{DDB} = 2.5V	14.7	19.4	
			V _{DDB} = 1.8V	11.9	15.9	

DC Electrical Characteristics (continued)

(V_{DDA} - V_{GNDA} = +1.71V to +5.5V, V_{DDB} - V_{GNDB} = +1.71V to +5.5V, C_L = 15pF, T_A = -40°C to +125°C, unless otherwise noted. Typical values are at V_{DDA} - V_{GNDA} = +3.3V, V_{DDB} - V_{GNDB} = +3.3V, V_{GNDA} = V_{GNDB}, T_A = +25°C, unless otherwise noted.) (Note 1)

PARAMETER	SYMBOL	CONDITIONS	MIN	TYP	MAX	UNITS
Supply Current (MAX14936_)	I _{DDA}	500kHz square wave	V _{DDA} = 5V	5.2	7.2	mA
			V _{DDA} = 3.3V	5.2	7.2	
			V _{DDA} = 2.5V	5.2	7.2	
			V _{DDA} = 1.8V	5	7.0	
		12.5MHz square wave (Note 2)	V _{DDA} = 5V	8.2	10.0	
			V _{DDA} = 3.3V	7.2	9.1	
			V _{DDA} = 2.5V	6.7	8.7	
			V _{DDA} = 1.8V	6.3	8.2	
		50MHz square wave (Note 2)	V _{DDA} = 5V	18	23.3	
			V _{DDA} = 3.3V	14.2	18.4	
			V _{DDA} = 2.5V	12.3	16.1	
			V _{DDA} = 1.8V	10.5	13.6	
	I _{DDB}	500kHz square wave	V _{DDB} = 5V	5.2	7.2	
			V _{DDB} = 3.3V	5.2	7.2	
			V _{DDB} = 2.5V	5.2	7.2	
			V _{DDB} = 1.8V	5	7.0	
		12.5MHz square wave (Note 2)	V _{DDB} = 5V	8.2	10.0	
			V _{DDB} = 3.3V	7.2	9.1	
			V _{DDB} = 2.5V	6.7	8.7	
			V _{DDB} = 1.8V	6.3	8.2	
		50MHz square wave (Note 2)	V _{DDB} = 5V	18	23.3	
			V _{DDB} = 3.3V	14.2	18.4	
			V _{DDB} = 2.5V	12.3	16.1	
			V _{DDB} = 1.8V	10.5	13.6	

DC Electrical Characteristics (continued)

($V_{DDA} - V_{GNDA} = +1.71V$ to $+5.5V$, $V_{DDB} - V_{GNDB} = +1.71V$ to $+5.5V$, $C_L = 15pF$, $T_A = -40^{\circ}C$ to $+125^{\circ}C$, unless otherwise noted. Typical values are at $V_{DDA} - V_{GNDA} = +3.3V$, $V_{DDB} - V_{GNDB} = +3.3V$, $V_{GNDA} = V_{GNDB}$, $T_A = +25^{\circ}C$, unless otherwise noted.) (Note 1)

PARAMETER	SYMBOL	CONDITIONS	MIN	TYP	MAX	UNITS
LOGIC INPUTS AND OUTPUTS						
Input High Voltage	V_{IH}	ENA, INA_ relative to GNDA	0.7 x V_{DDA}			V
		ENB, INB_ relative to GNDB	0.7 x V_{DDB}			
Input Low Voltage	V_{IL}	ENA, INA_ relative to GNDA	$1.71V \leq V_{DDA} \leq 1.89V$	0.6		V
			$2.25V \leq V_{DDA} \leq 5.5V$	0.8		
		ENB, INB_ relative to GNDB	$1.71V \leq V_{DDB} \leq 1.89V$	0.6		
			$2.25V \leq V_{DDB} \leq 5.5V$	0.8		
Input Hysteresis	V_{HYS}	$V_{INA_}$ relative to GNDA or $V_{INB_}$ relative to GNDB	MAX1493_A/D	410		mV
			MAX1493_B/E	410		
			MAX1493_C/F	80		
Input Leakage Current	I_L	$V_{INA_} = 0$ or V_{DDA} , $V_{INB_} = 0$ or V_{DDB}	-1		+1	μA
Input Capacitance	C_{IN}	INA_, INB_, $f = 1MHz$		2		pF
EN_ Pullup Current	I_{PU}		-4	-2.3	-1	μA
Output Voltage High	V_{OH}	$V_{OUTA_}$ relative to GNDA, $I_{OUTA_} = -4mA$ (Note 3)	$V_{DDA} - 0.4$			V
		$V_{OUTB_}$ relative to GNDB, $I_{OUTB_} = -4mA$ (Note 3)	$V_{DDB} - 0.4$			
Output Voltage Low	V_{OL}	$V_{OUTA_}$ relative to GNDA, $I_{OUTA_} = 4mA$ (Note 3)	0.4			V
		$V_{OUTB_}$ relative to GNDB, $I_{OUTB_} = 4mA$ (Note 3)	0.4			

Dynamic Electrical Characteristics (MAX1493_A/D)

(V_{DDA} - V_{GNDA} = +1.71V to +5.5V, V_{DDB} - V_{GNDB} = +1.71V to +5.5V, C_L = 15pF, T_A = -40°C to +125°C, unless otherwise noted. Typical values are at V_{DDA} - V_{GNDA} = +3.3V, V_{DDB} - V_{GNDB} = +3.3V, V_{GNDA} = V_{GNDB}, T_A = +25°C, unless otherwise noted.) (Notes 1, 2)

PARAMETER	SYMBOL	CONDITIONS	MIN	TYP	MAX	UNITS
INPUT AND OUTPUT CHANNELS						
Common-Mode Transient Immunity	CMTI	IN__ = GND_ or VDD_ (Note 4)		25		kV/μs
Maximum Data Rate	DR _{MAX}		1			Mbps
Minimum Pulse Width	PW _{MIN}	INA_ to OUTB_, INB_ to OUTA_			1	μs
Glitch Rejection		INA_ to OUTB_, INB_ to OUTA_		32		ns
Propagation Delay (Figure 1)	t _{PLH}	INA_ to OUTB_, INB_ to OUTA_, C _L = 15pF	4.5V ≤ V _{DDA} , V _{DDB} ≤ 5.5V	38.2	54.1	ns
			3.0V ≤ V _{DDA} , V _{DDB} ≤ 3.6V	38.7	54.6	
			2.25V ≤ V _{DDA} , V _{DDB} ≤ 2.75V	39.7	55.6	
			1.71V ≤ V _{DDA} , V _{DDB} ≤ 1.89V	42.9	58.4	
	t _{PHL}	INA_ to OUTB_, INB_ to OUTA_, C _L = 15pF	4.5V ≤ V _{DDA} , V _{DDB} ≤ 5.5V	38.6	55.3	
			3.0V ≤ V _{DDA} , V _{DDB} ≤ 3.6V	38.9	55.6	
			2.25V ≤ V _{DDA} , V _{DDB} ≤ 2.75V	39.8	56.1	
			1.71V ≤ V _{DDA} , V _{DDB} ≤ 1.89V	42.3	60.2	
Pulse-Width Distortion	PWD	t _{PLH} - t _{PHL}	4.5V ≤ V _{DDA} , V _{DDB} ≤ 5.5V	0.4	4.5	ns
			3.0V ≤ V _{DDA} , V _{DDB} ≤ 3.6V	0.2	4.3	
			2.25V ≤ V _{DDA} , V _{DDB} ≤ 2.75V	0.1	3.9	
			1.71V ≤ V _{DDA} , V _{DDB} ≤ 1.89V	0.6	4.7	
Propagation Delay Skew Part-to-Part (Same Channel)	t _{SPLH}		4.5V ≤ V _{DDA} , V _{DDB} ≤ 5.5V		26.6	ns
			3.0V ≤ V _{DDA} , V _{DDB} ≤ 3.6V		26.6	
			2.25V ≤ V _{DDA} , V _{DDB} ≤ 2.75V		26.6	
			1.71V ≤ V _{DDA} , V _{DDB} ≤ 1.89V		26.9	
	t _{SPHL}		4.5V ≤ V _{DDA} , V _{DDB} ≤ 5.5V		27.9	
			3.0V ≤ V _{DDA} , V _{DDB} ≤ 3.6V		27.7	
			2.25V ≤ V _{DDA} , V _{DDB} ≤ 2.75V		27.6	
			1.71V ≤ V _{DDA} , V _{DDB} ≤ 1.89V		29.7	
Propagation Delay Skew Channel-to-Channel (Same Direction)	t _{SCSLH}		4.5V ≤ V _{DDA} , V _{DDB} ≤ 5.5V		6.7	ns
			3.0V ≤ V _{DDA} , V _{DDB} ≤ 3.6V		6.7	
			2.25V ≤ V _{DDA} , V _{DDB} ≤ 2.75V		6.7	
			1.71V ≤ V _{DDA} , V _{DDB} ≤ 1.89V		6.7	
	t _{SCSHL}		4.5V ≤ V _{DDA} , V _{DDB} ≤ 5.5V		6.7	
			3.0V ≤ V _{DDA} , V _{DDB} ≤ 3.6V		6.7	
			2.25V ≤ V _{DDA} , V _{DDB} ≤ 2.75V		6.7	
			1.71V ≤ V _{DDA} , V _{DDB} ≤ 1.89V		6.7	

Dynamic Electrical Characteristics (MAX1493_A/D) (Continued)

(V_{DDA} - V_{GNDA} = +1.71V to +5.5V, V_{DDB} - V_{GNDB} = +1.71V to +5.5V, C_L = 15pF, T_A = -40°C to +125°C, unless otherwise noted. Typical values are at V_{DDA} - V_{GNDA} = +3.3V, V_{DDB} - V_{GNDB} = +3.3V, V_{GNDA} = V_{GNDB}, T_A = +25°C, unless otherwise noted.) (Notes 1, 2)

PARAMETER	SYMBOL	CONDITIONS	MIN	TYP	MAX	UNITS
Propagation Delay Skew Channel-to-Channel (Opposing Direction)	t _{SCOLH}	4.5V ≤ V _{DDA} , V _{DDB} ≤ 5.5V			26.6	ns
		3.0V ≤ V _{DDA} , V _{DDB} ≤ 3.6V			26.6	
		2.25V ≤ V _{DDA} , V _{DDB} ≤ 2.75V			26.6	
		1.71V ≤ V _{DDA} , V _{DDB} ≤ 1.89V			26.9	
	t _{SCOHL}	4.5V ≤ V _{DDA} , V _{DDB} ≤ 5.5V			27.9	
		3.0V ≤ V _{DDA} , V _{DDB} ≤ 3.6V			27.7	
		2.25V ≤ V _{DDA} , V _{DDB} ≤ 2.75V			27.6	
		1.71V ≤ V _{DDA} , V _{DDB} ≤ 1.89V			29.7	
Rise Time (Figure 1)	t _R	4.5V ≤ V _{DDA} , V _{DDB} ≤ 5.5V		2	ns	
		3.0V ≤ V _{DDA} , V _{DDB} ≤ 3.6V		2		
		2.25V ≤ V _{DDA} , V _{DDB} ≤ 2.75V		2		
		1.71V ≤ V _{DDA} , V _{DDB} ≤ 1.89V		2		
Fall Time (Figure 1)	t _F	4.5V ≤ V _{DDA} , V _{DDB} ≤ 5.5V		2	ns	
		3.0V ≤ V _{DDA} , V _{DDB} ≤ 3.6V		2		
		2.25V ≤ V _{DDA} , V _{DDB} ≤ 2.75V		2		
		1.71V ≤ V _{DDA} , V _{DDB} ≤ 1.89V		2		
Enable to Data Valid	t _{EN}	4.5V ≤ V _{DDA} , V _{DDB} ≤ 5.5V			5.1	ns
		3.0V ≤ V _{DDA} , V _{DDB} ≤ 3.6V			5.5	
		2.25V ≤ V _{DDA} , V _{DDB} ≤ 2.75V			6.7	
		1.71V ≤ V _{DDA} , V _{DDB} ≤ 1.89V			16.3	
Enable to Three-State	t _{TRI}	4.5V ≤ V _{DDA} , V _{DDB} ≤ 5.5V			2.7	ns
		3.0V ≤ V _{DDA} , V _{DDB} ≤ 3.6V			4.4	
		2.25V ≤ V _{DDA} , V _{DDB} ≤ 2.75V			7.0	
		1.71V ≤ V _{DDA} , V _{DDB} ≤ 1.89V			11.7	

Dynamic Electrical Characteristics (MAX1493_B/E)

(V_{DDA} - V_{GNDA} = +1.71V to +5.5V, V_{DDB} - V_{GNDB} = +1.71V to +5.5V, C_L = 15pF, T_A = -40°C to +125°C, unless otherwise noted. Typical values are at V_{DDA} - V_{GNDA} = +3.3V, V_{DDB} - V_{GNDB} = +3.3V, V_{GNDA} = V_{GNDB}, T_A = +25°C, unless otherwise noted.) (Notes 1, 2)

PARAMETER	SYMBOL	CONDITIONS	MIN	TYP	MAX	UNITS
INPUT AND OUTPUT CHANNELS						
Common-Mode Transient Immunity	CMTI	IN__ = GND_ or V _{DD} _ (Note 4)		25		kV/μs
Maximum Data Rate	DR _{MAX}		25			Mbps
Minimum Pulse Width	PW _{MIN}	INA_ to OUTB_, INB_ to OUTA_			40	ns
Glitch Rejection		INA_ to OUTB_, INB_ to OUTA_		15		ns
Propagation Delay (Figure 1)	t _{PLH}	INA_ to OUTB_, INB_ to OUTA_, C _L = 15pF	4.5V ≤ V _{DDA} , V _{DDB} ≤ 5.5V	20.9	27.5	ns
			3.0V ≤ V _{DDA} , V _{DDB} ≤ 3.6V	21.4	28.7	
			2.25V ≤ V _{DDA} , V _{DDB} ≤ 2.75V	22.4	31.2	
			1.71V ≤ V _{DDA} , V _{DDB} ≤ 1.89V	25.7	36.9	
	t _{PHL}	INA_ to OUTB_, INB_ to OUTA_, C _L = 15pF	4.5V ≤ V _{DDA} , V _{DDB} ≤ 5.5V	21.1	28.8	
			3.0V ≤ V _{DDA} , V _{DDB} ≤ 3.6V	21.5	29.8	
			2.25V ≤ V _{DDA} , V _{DDB} ≤ 2.75V	22.3	31.9	
			1.71V ≤ V _{DDA} , V _{DDB} ≤ 1.89V	24.9	37.4	
Pulse-Width Distortion	PWD	t _{PLH} - t _{PHL}	4.5V ≤ V _{DDA} , V _{DDB} ≤ 5.5V	0.2	2.6	ns
			3.0V ≤ V _{DDA} , V _{DDB} ≤ 3.6V	0.1	2.6	
			2.25V ≤ V _{DDA} , V _{DDB} ≤ 2.75V	0.1	2.4	
			1.71V ≤ V _{DDA} , V _{DDB} ≤ 1.89V	0.7	3.2	
Propagation Delay Skew Part-to-Part (Same Channel)	t _{SPLH}		4.5V ≤ V _{DDA} , V _{DDB} ≤ 5.5V		11.7	ns
			3.0V ≤ V _{DDA} , V _{DDB} ≤ 3.6V		11.5	
			2.25V ≤ V _{DDA} , V _{DDB} ≤ 2.75V		11.3	
			1.71V ≤ V _{DDA} , V _{DDB} ≤ 1.89V		13.6	
	t _{SPHL}		4.5V ≤ V _{DDA} , V _{DDB} ≤ 5.5V		9.8	
			3.0V ≤ V _{DDA} , V _{DDB} ≤ 3.6V		9.8	
			2.25V ≤ V _{DDA} , V _{DDB} ≤ 2.75V		11.1	
			1.71V ≤ V _{DDA} , V _{DDB} ≤ 1.89V		14.4	
Propagation Delay Skew Channel-to-Channel (Same Direction)	t _{SCSLH}		4.5V ≤ V _{DDA} , V _{DDB} ≤ 5.5V		3	ns
			3.0V ≤ V _{DDA} , V _{DDB} ≤ 3.6V		3	
			2.25V ≤ V _{DDA} , V _{DDB} ≤ 2.75V		3	
			1.71V ≤ V _{DDA} , V _{DDB} ≤ 1.89V		3	
	t _{SCSHL}		4.5V ≤ V _{DDA} , V _{DDB} ≤ 5.5V		3	
			3.0V ≤ V _{DDA} , V _{DDB} ≤ 3.6V		3	
			2.25V ≤ V _{DDA} , V _{DDB} ≤ 2.75V		3	
			1.71V ≤ V _{DDA} , V _{DDB} ≤ 1.89V		3	

Dynamic Electrical Characteristics (MAX1493_B/E) (Continued)

($V_{DDA} - V_{GNDA} = +1.71V$ to $+5.5V$, $V_{DDB} - V_{GNDB} = +1.71V$ to $+5.5V$, $C_L = 15pF$, $T_A = -40^\circ C$ to $+125^\circ C$, unless otherwise noted. Typical values are at $V_{DDA} - V_{GNDA} = +3.3V$, $V_{DDB} - V_{GNDB} = +3.3V$, $V_{GNDA} = V_{GNDB}$, $T_A = +25^\circ C$, unless otherwise noted.) (Notes 1, 2)

PARAMETER	SYMBOL	CONDITIONS	MIN	TYP	MAX	UNITS
Propagation Delay Skew Channel to Channel (Opposing Direction)	t _{SCOLH}	4.5V ≤ V _{DDA} , V _{DDB} ≤ 5.5V			11.7	ns
		3.0V ≤ V _{DDA} , V _{DDB} ≤ 3.6V			11.5	
		2.25V ≤ V _{DDA} , V _{DDB} ≤ 2.75V			11.3	
		1.71V ≤ V _{DDA} , V _{DDB} ≤ 1.89V			13.6	
	t _{SCOHL}	4.5V ≤ V _{DDA} , V _{DDB} ≤ 5.5V			9.8	
		3.0V ≤ V _{DDA} , V _{DDB} ≤ 3.6V			9.8	
		2.25V ≤ V _{DDA} , V _{DDB} ≤ 2.75V			11.1	
		1.71V ≤ V _{DDA} , V _{DDB} ≤ 1.89V			14.4	
Rise Time (Figure 1)	t _R	4.5V ≤ V _{DDA} , V _{DDB} ≤ 5.5V		2	ns	
		3.0V ≤ V _{DDA} , V _{DDB} ≤ 3.6V		2		
		2.25V ≤ V _{DDA} , V _{DDB} ≤ 2.75V		2		
		1.71V ≤ V _{DDA} , V _{DDB} ≤ 1.89V		2		
Fall Time (Figure 1)	t _F	4.5V ≤ V _{DDA} , V _{DDB} ≤ 5.5V		2	ns	
		3.0V ≤ V _{DDA} , V _{DDB} ≤ 3.6V		2		
		2.25V ≤ V _{DDA} , V _{DDB} ≤ 2.75V		2		
		1.71V ≤ V _{DDA} , V _{DDB} ≤ 1.89V		2		
Enable to Data Valid	t _{EN}	4.5V ≤ V _{DDA} , V _{DDB} ≤ 5.5V			5.1	ns
		3.0V ≤ V _{DDA} , V _{DDB} ≤ 3.6V			5.5	
		2.25V ≤ V _{DDA} , V _{DDB} ≤ 2.75V			6.7	
		1.71V ≤ V _{DDA} , V _{DDB} ≤ 1.89V			16.3	
Enable to Three-State	t _{TRI}	4.5V ≤ V _{DDA} , V _{DDB} ≤ 5.5V			2.7	ns
		3.0V ≤ V _{DDA} , V _{DDB} ≤ 3.6V			4.4	
		2.25V ≤ V _{DDA} , V _{DDB} ≤ 2.75V			7.0	
		1.71V ≤ V _{DDA} , V _{DDB} ≤ 1.89V			11.7	

Dynamic Electrical Characteristics (MAX1493_C/F)

(V_{DDA} - V_{GND A} = +1.71V to +5.5V, V_{DDB} - V_{GND B} = +1.71V to +5.5V, C_L = 15pF, T_A = -40°C to +125°C, unless otherwise noted. Typical values are at V_{DDA} - V_{GND A} = +3.3V, V_{DDB} - V_{GND B} = +3.3V, V_{GND A} = V_{GND B}, T_A = +25°C, unless otherwise noted.) (Notes 1, 2)

PARAMETER	SYMBOL	CONDITIONS	MIN	TYP	MAX	UNITS
INPUT AND OUTPUT CHANNELS						
Common-Mode Transient Immunity	CMTI	IN _{__} = GND _{__} or V _{DD} _{__} (Note 4)		25		kV/μs
Maximum Data Rate	DR _{MAX}		150			Mbps
Minimum Pulse Width	PW _{MIN}	INA _{__} to OUTB _{__} , INB _{__} to OUTB _{__}			6.67	ns
Propagation Delay (Figure 1)	t _{PLH}	INA _{__} to OUTB _{__} , INB _{__} to OUTA _{__} , C _L = 15pF	4.5V ≤ V _{DDA} , V _{DDB} ≤ 5.5V	5.1	7.5	ns
			3.0V ≤ V _{DDA} , V _{DDB} ≤ 3.6V	5.2	8.1	
			2.25V ≤ V _{DDA} , V _{DDB} ≤ 2.75V	5.8	9.7	
			1.71V ≤ V _{DDA} , V _{DDB} ≤ 1.89V	8.1	14	
	t _{PHL}	INA _{__} to OUTB _{__} , INB _{__} to OUTA _{__} , C _L = 15pF	4.5V ≤ V _{DDA} , V _{DDB} ≤ 5.5V	4.9	7.4	
			3.0V ≤ V _{DDA} , V _{DDB} ≤ 3.6V	5.3	8.3	
			2.25V ≤ V _{DDA} , V _{DDB} ≤ 2.75V	5.9	10.2	
			1.71V ≤ V _{DDA} , V _{DDB} ≤ 1.89V	8.2	14.9	
Pulse-Width Distortion	PWD	t _{PLH} - t _{PHL}	4.5V ≤ V _{DDA} , V _{DDB} ≤ 5.5V	0.2	1	ns
			3.0V ≤ V _{DDA} , V _{DDB} ≤ 3.6V	0.1	1	
			2.25V ≤ V _{DDA} , V _{DDB} ≤ 2.75V	0.1	1	
			1.71V ≤ V _{DDA} , V _{DDB} ≤ 1.89V	0.1	1	
Propagation Delay Skew Part-to-Part (Same Channel)	t _{SPLH}		4.5V ≤ V _{DDA} , V _{DDB} ≤ 5.5V		3.0	ns
			3.0V ≤ V _{DDA} , V _{DDB} ≤ 3.6V		3.3	
			2.25V ≤ V _{DDA} , V _{DDB} ≤ 2.75V		4.3	
			1.71V ≤ V _{DDA} , V _{DDB} ≤ 1.89V		7.1	
	t _{SPHL}		4.5V ≤ V _{DDA} , V _{DDB} ≤ 5.5V		2.8	
			3.0V ≤ V _{DDA} , V _{DDB} ≤ 3.6V		3.4	
			2.25V ≤ V _{DDA} , V _{DDB} ≤ 2.75V		4.6	
			1.71V ≤ V _{DDA} , V _{DDB} ≤ 1.89V		7.9	
Propagation Delay Skew Channel-to-Channel (Same Direction)	t _{SCSLH}		4.5V ≤ V _{DDA} , V _{DDB} ≤ 5.5V		0.9	ns
			3.0V ≤ V _{DDA} , V _{DDB} ≤ 3.6V		1.2	
			2.25V ≤ V _{DDA} , V _{DDB} ≤ 2.75V		1.4	
			1.71V ≤ V _{DDA} , V _{DDB} ≤ 1.89V		1.6	
	t _{SCSHL}		4.5V ≤ V _{DDA} , V _{DDB} ≤ 5.5V		0.9	
			3.0V ≤ V _{DDA} , V _{DDB} ≤ 3.6V		1.2	
			2.25V ≤ V _{DDA} , V _{DDB} ≤ 2.75V		1.4	
			1.71V ≤ V _{DDA} , V _{DDB} ≤ 1.89V		1.6	

Dynamic Electrical Characteristics (MAX1493_C/F) (continued)

(V_{DDA} - V_{GNDA} = +1.71V to +5.5V, V_{DDB} - V_{GNDB} = +1.71V to +5.5V, C_L = 15pF, T_A = -40°C to +125°C, unless otherwise noted. Typical values are at V_{DDA} - V_{GNDA} = +3.3V, V_{DDB} - V_{GNDB} = +3.3V, V_{GNDA} = V_{GNDB}, T_A = +25°C, unless otherwise noted.) (Notes 1, 2)

PARAMETER	SYMBOL	CONDITIONS	MIN	TYP	MAX	UNITS
Propagation Delay Skew Channel-to-Channel (Opposing Direction)	t _{SCOLH}	4.5V ≤ V _{DDA} , V _{DDB} ≤ 5.5V			3	ns
		3.0V ≤ V _{DDA} , V _{DDB} ≤ 3.6V			3.3	
		2.25V ≤ V _{DDA} , V _{DDB} ≤ 2.75V			4.3	
		1.71V ≤ V _{DDA} , V _{DDB} ≤ 1.89V			7.1	
	t _{SCOHL}	4.5V ≤ V _{DDA} , V _{DDB} ≤ 5.5V			2.8	
		3.0V ≤ V _{DDA} , V _{DDB} ≤ 3.6V			3.4	
		2.25V ≤ V _{DDA} , V _{DDB} ≤ 2.75V			4.6	
		1.71V ≤ V _{DDA} , V _{DDB} ≤ 1.89V			7.9	
Rise Time (Figure 1)	t _R	4.5V ≤ V _{DDA} , V _{DDB} ≤ 5.5V		2	ns	
		3.0V ≤ V _{DDA} , V _{DDB} ≤ 3.6V		2		
		2.25V ≤ V _{DDA} , V _{DDB} ≤ 2.75V		2		
		1.71V ≤ V _{DDA} , V _{DDB} ≤ 1.89V		2		
Fall Time (Figure 1)	t _F	4.5V ≤ V _{DDA} , V _{DDB} ≤ 5.5V		2	ns	
		3.0V ≤ V _{DDA} , V _{DDB} ≤ 3.6V		2		
		2.25V ≤ V _{DDA} , V _{DDB} ≤ 2.75V		2		
		1.71V ≤ V _{DDA} , V _{DDB} ≤ 1.89V		2		
Enable to Data Valid	t _{EN}	4.5V ≤ V _{DDA} , V _{DDB} ≤ 5.5V			5.1	ns
		3.0V ≤ V _{DDA} , V _{DDB} ≤ 3.6V			5.5	
		2.25V ≤ V _{DDA} , V _{DDB} ≤ 2.75V			6.7	
		1.71V ≤ V _{DDA} , V _{DDB} ≤ 1.89V			16.3	
Enable to Three-State	t _{TRI}	4.5V ≤ V _{DDA} , V _{DDB} ≤ 5.5V			2.7	ns
		3.0V ≤ V _{DDA} , V _{DDB} ≤ 3.6V			4.4	
		2.25V ≤ V _{DDA} , V _{DDB} ≤ 2.75V			7.0	
		V _{DDA} , V _{DDB} ≤ 1.89V			11.7	
Peak Eye Diagram Jitter	T _{JIT(PK)}	V _{DDA} , V _{DDB} = 5.0V			140	ps
		V _{DDA} , V _{DDB} = 3.3V			130	
		V _{DDA} , V _{DDB} = 2.5V			140	
		V _{DDA} , V _{DDB} = 1.8V			160	

ESD Protection

PARAMETER	SYMBOL	CONDITIONS	MIN	TYP	MAX	UNITS
ESD		Human Body Model, All Pins		±4		kV

- Note 1:** All devices are 100% production tested at T_A = +125°C. Specifications over temperature are guaranteed by design.
- Note 2:** Not production tested. Guaranteed by design.
- Note 3:** All currents into the device are positive. All currents out of the device are negative.
- Note 4:** CMTI is the maximum sustainable common-mode voltage slew rate while maintaining the correct output. CMTI applies to both rising and falling common-mode voltage edges. Tested with the transient generator connected between GNDA and GNDB (V_{CM} = 1000V).

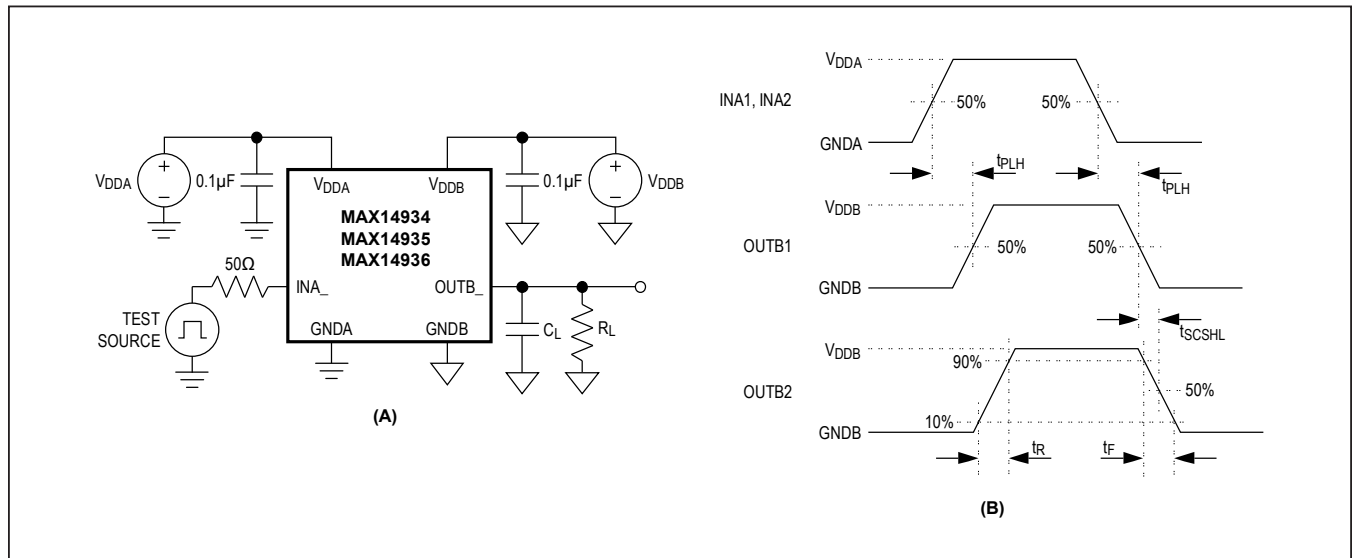

Figure 1. Test Circuit (A) and Timing Diagram (B)

Safety Regulatory Approvals

UL
The MAX14934–MAX14936 are certified under UL1577. For more details, refer to File E351759.
Rated up to 5000V _{RMS} isolation voltage for single protection.
cUL (Equivalent to CSA notice 5A)
The MAX14934-MAX14936 are certified up to 5000V _{RMS} for single protection. For more details, refer to File E351759.
VDE
The MAX14934-MAX14936 are certified to DIN VDE V 0884-11: 2017-01. For details, see file ref. 5015017-4880-0001/272147/TL7/ SCT. Basic Insulation, Maximum Transient Isolation Voltage 8400V _{PK} , Maximum Repetitive Peak Isolation Voltage 1200V _{PK}

This coupler is suitable for “safe electrical insulation” only within the safety ratings. Compliance with the safety ratings shall be ensured by means of suitable protective circuits.

IEC Insulation Testing

TUV
The MAX14934-MAX14936 are tested under TUV.
IEC 60950-1: Up to 1200V _{PK} (848V _{RMS}) working voltage for basic insulation.
IEC 61010-1 (ed. 3): Up to 848V _{RMS} working voltage for basic insulation. For details, see Technical Report number 095-72100581-100.
IEC 60601-1 (ed. 3): For details see Technical Report number 095-72100581-200.
Basic insulation 1 MOOP, 1200V _{PK} (848V _{RMS})
Withstand isolation voltage (V _{ISO}) for 60s, 5000V _{RMS}

MAX14934–MAX14936 Insulation Characteristics

PARAMETER	SYMBOL	CONDITIONS	VALUE	UNITS
Partial Discharge Test Voltage	V _{PR}	Method B1 = V _{IORM} × 1.875 (t = 1s, partial discharge < 5pC)	2250	V _P
Maximum Repetitive Peak Isolation Voltage	V _{IORM}	(Note 5)	1200	V _P
Maximum Working Isolation Voltage	V _{IOWM}	Continuous RMS voltage (Note 5)	848	V _{RMS}
Maximum Transient Isolation Voltage	V _{IOTM}	t = 1s (Note 5)	8400	V _P
Maximum Withstand Isolation Voltage	V _{ISO}	f _{SW} = 60Hz, duration = 60s (Note 5, 6)	5000	V _{RMS}
Maximum Surge Isolation Voltage	V _{IOSM}	Basic insulation, 1.2/50μs pulse per IEC 61000-4-5 (Note 5, 7)	10	kV
Insulation Resistance	R _{IO}	V _{IO} = 500V, T _A = 25°C	> 10 ¹²	Ω
		V _{IO} = 500V, 100°C ≤ T _A ≤ 125°C	> 10 ¹¹	
		V _{IO} = 500V at T _S = 150°C	> 10 ⁹	
Barrier Capacitance Side A to Side B	C _{IO}	f _{SW} = 1MHz (Note 8)	2	pF
Minimum Creepage Distance	CPG	Wide SOIC	8	mm
Minimum Clearance Distance	CLR	Wide SOIC	8	mm
Internal Clearance		Distance through insulation	0.015	mm
Comparative Tracking Index	CTI	Material Group II (IEC 60112)	575	
Climatic Category			40/125/21	
Pollution Degree (DIN VDE 0110, Table 1)			2	

Note 5: V_{ISO}, V_{IOTM}, V_{IOSM}, V_{IOWM}, and V_{IORM} are defined by the IEC 60747-5-5 standard.

Note 6: Products are qualified at V_{ISO} for 60s and 100% production tested at 120% of V_{ISO} for 1s.

Note 7: Devices are immersed in oil during surge characterization.

Note 8: Capacitance is measured with all pins on field-side and logic-side tied together.

Safety Limits

Damage to the IC can result in a low-resistance path to ground or to the supply and, without current limiting, the MAX14934–MAX14936 could dissipate excessive amounts of power. Excessive power dissipation can damage the die and result in damage to the isolation barrier, potentially causing downstream issues. [Table 1](#) shows the safety limits for the MAX14934–MAX14936.

The maximum safety temperature (T_S) for the device is the 150°C maximum junction temperature specified in the [Absolute Maximum Ratings](#). The power dissipation (P_D) and junction-to-ambient thermal impedance (θ_{JA})

determine the junction temperature. Thermal impedance values (θ_{JA} and θ_{JC}) are available in the [Package Information](#) section of the datasheet. Calculate the junction temperature (T_J) as:

$$T_J = T_A + (P_D \times \theta_{JA})$$

[Figure 2](#) to [Figure 3](#) show the thermal derating curves for the safety power limiting and safety current limiting of the devices. Ensure that the junction temperature does not exceed 150°C.

Table 1. Safety Limiting Values for the MAX14934–MAX14936

PARAMETER	SYMBOL	TEST CONDITIONS	MAX	UNITS
Safety Current on Any Pin (No Damage to Isolation Barrier)	I _S	T _J = 150°C, T _A = 25°C	300	mA
Total Safety Power Dissipation	P _S	T _J = 150°C, T _A = 25°C	1760	mW
Maximum Safety Temperature	T _S		150	°C

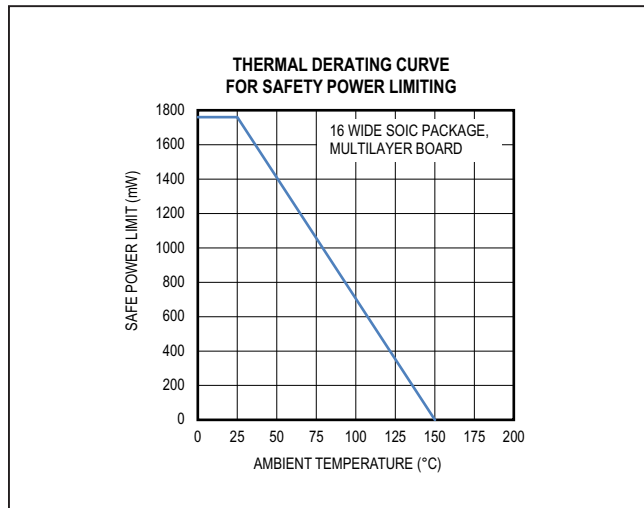

Figure 2. Thermal Derating Curve for Safety Power Limiting

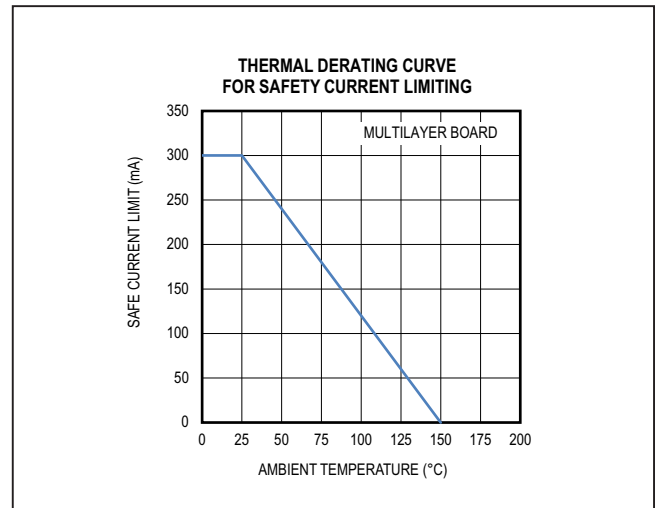
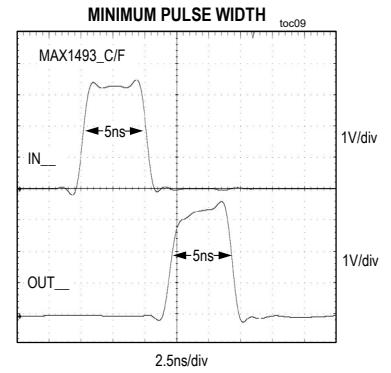
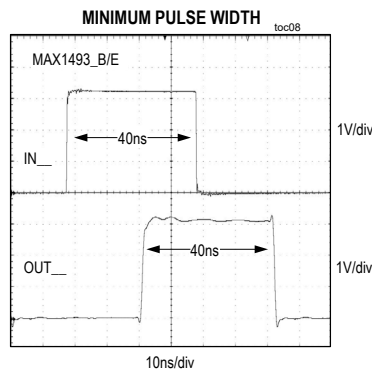
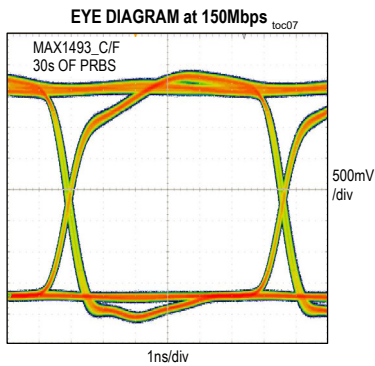
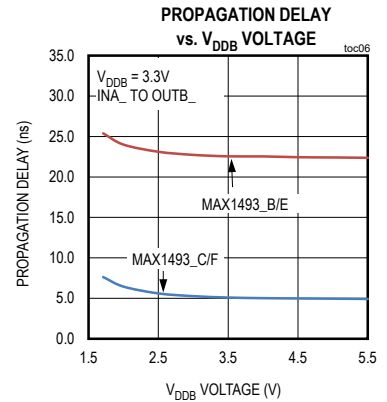
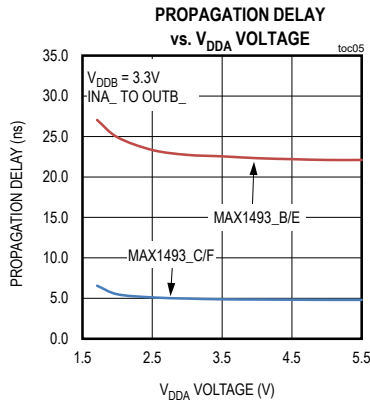
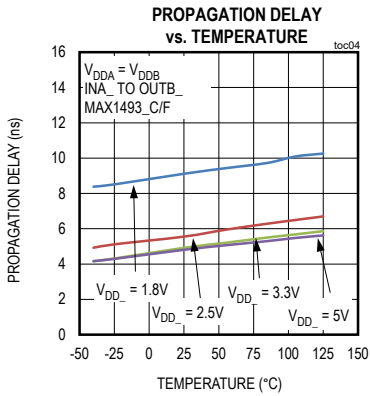
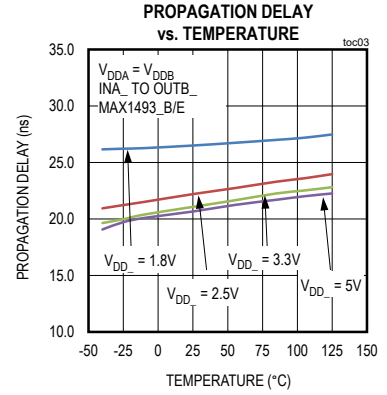
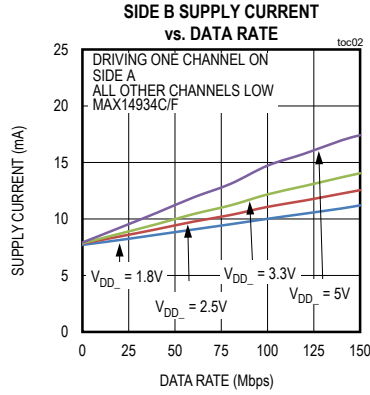
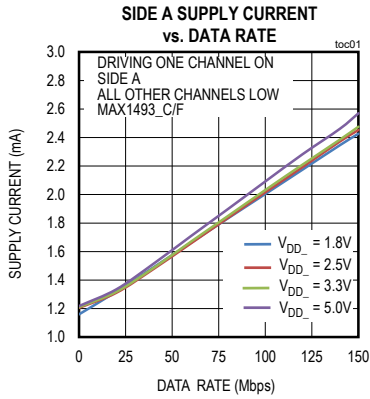

Figure 3. Thermal Derating Curve for Safety Current Limiting

Typical Operating Characteristics

($V_{DDA} - V_{GNDA} = +3.3V$, $V_{DDB} - V_{GNDB} = +3.3V$, $V_{GNDA} = V_{GNDB}$, $T_A = +25^\circ C$, unless otherwise noted.)



Pin Configurations

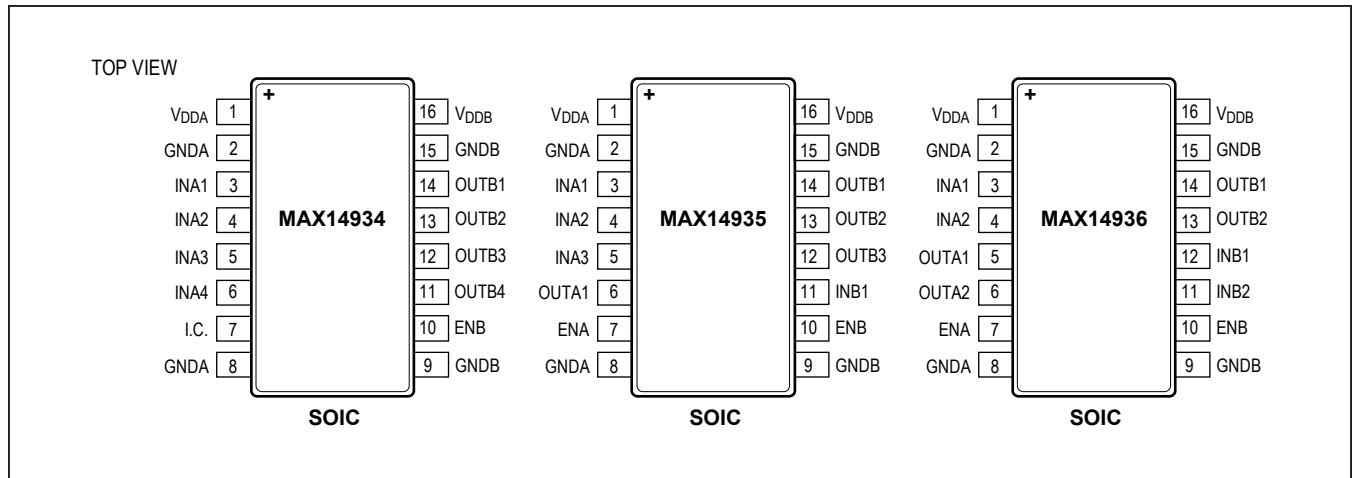

Pin Description

PIN			NAME	FUNCTION	VOLTAGE RELATIVE TO
MAX14934	MAX14935	MAX14936			
1	1	1	V _{DDA}	Power Supply. Bypass V _{DDA} with a 0.1µF ceramic capacitor as close as possible to the pin.	GNDA
2, 8	2, 8	2, 8	GNDA	Ground Reference for Side A	—
3	3	3	INA1	Logic Input 1 on Side A. INA1 corresponds to OUTB1.	GNDA
4	4	4	INA2	Logic Input 2 on Side A. INA2 corresponds to OUTB2.	GNDA
5	5	—	INA3	Logic Input 3 on Side A. INA3 corresponds to OUTB3.	GNDA
6	—	—	INA4	Logic Input 4 on Side A. INA4 corresponds to OUTB4.	GNDA
7	—	—	I.C.	Internally Connected. Leave unconnected or connect to GNDA or V _{DDA} .	—
—	6	5	OUTA1	Logic Output 1 on Side A	GNDA
—	—	6	OUTA2	Logic Output 2 on Side A	GNDA
—	7	7	ENA	Active-High Enable for Side A. ENA has an internal 2µA pullup to V _{DDA} .	GNDA
9, 15	9, 15	9, 15	GNDB	Ground Reference for Side B	—
10	10	10	ENB	Active-High Enable for Side B. ENB has an internal 2µA pullup to V _{DDDB} .	GNDB
11	—	—	OUTB4	Logic Output 4 on Side B	GNDB
—	11	12	INB1	Logic Input 1 on Side B. INB1 corresponds to OUTA1.	GNDB
—	—	11	INB2	Logic Input 2 on Side B. INB2 corresponds to OUTA2.	GNDB
12	12	—	OUTB3	Logic Output 3 on Side B	GNDB
13	13	13	OUTB2	Logic Output 2 on Side B	GNDB
14	14	14	OUTB1	Logic Output 1 on Side B	GNDB
16	16	16	V _{DDDB}	Power Supply. Bypass V _{DDDB} with a 0.1µF ceramic capacitor as close as possible to the pin.	GNDB

Typical Application Circuits

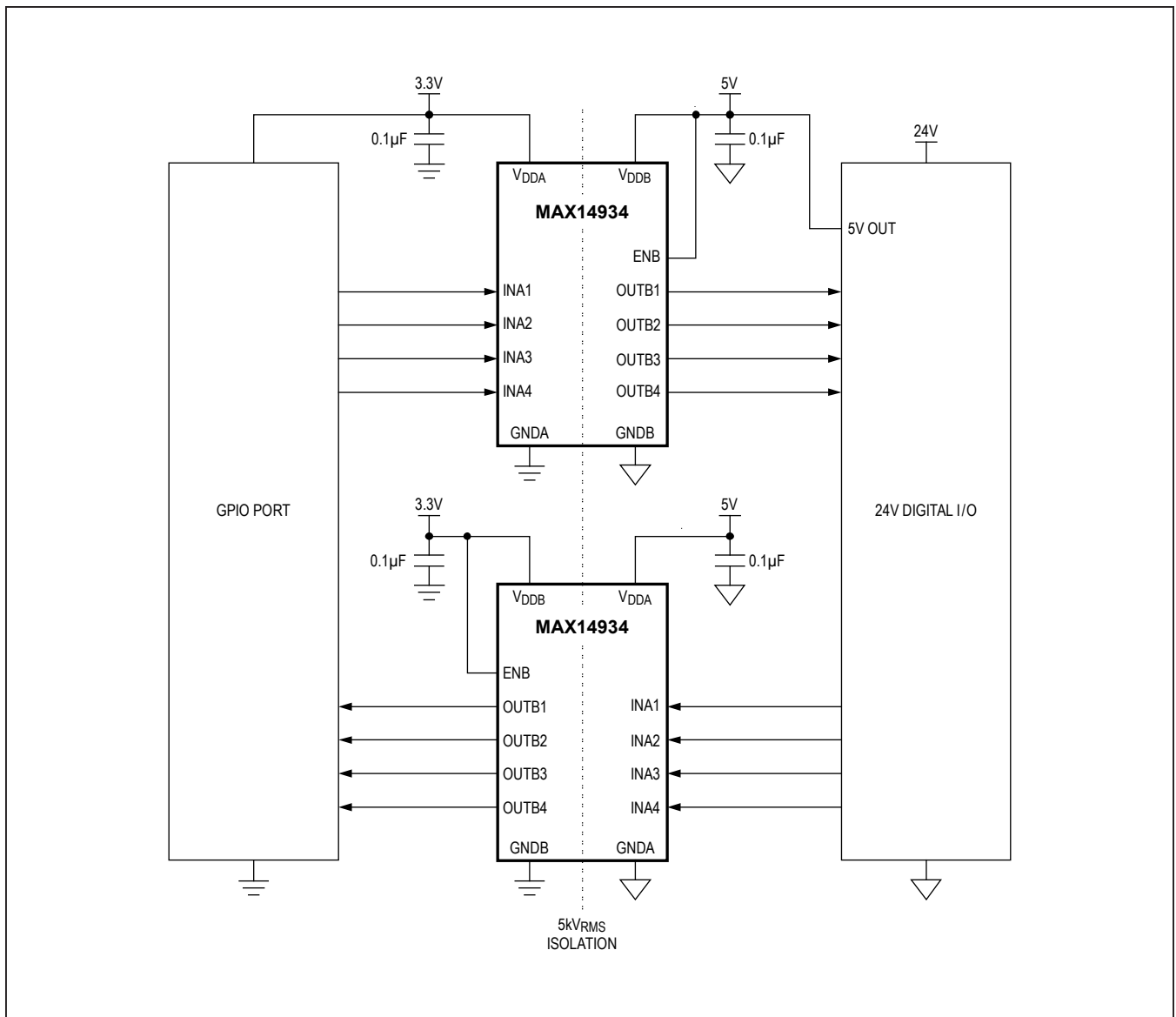

Typical Application Circuits (continued)

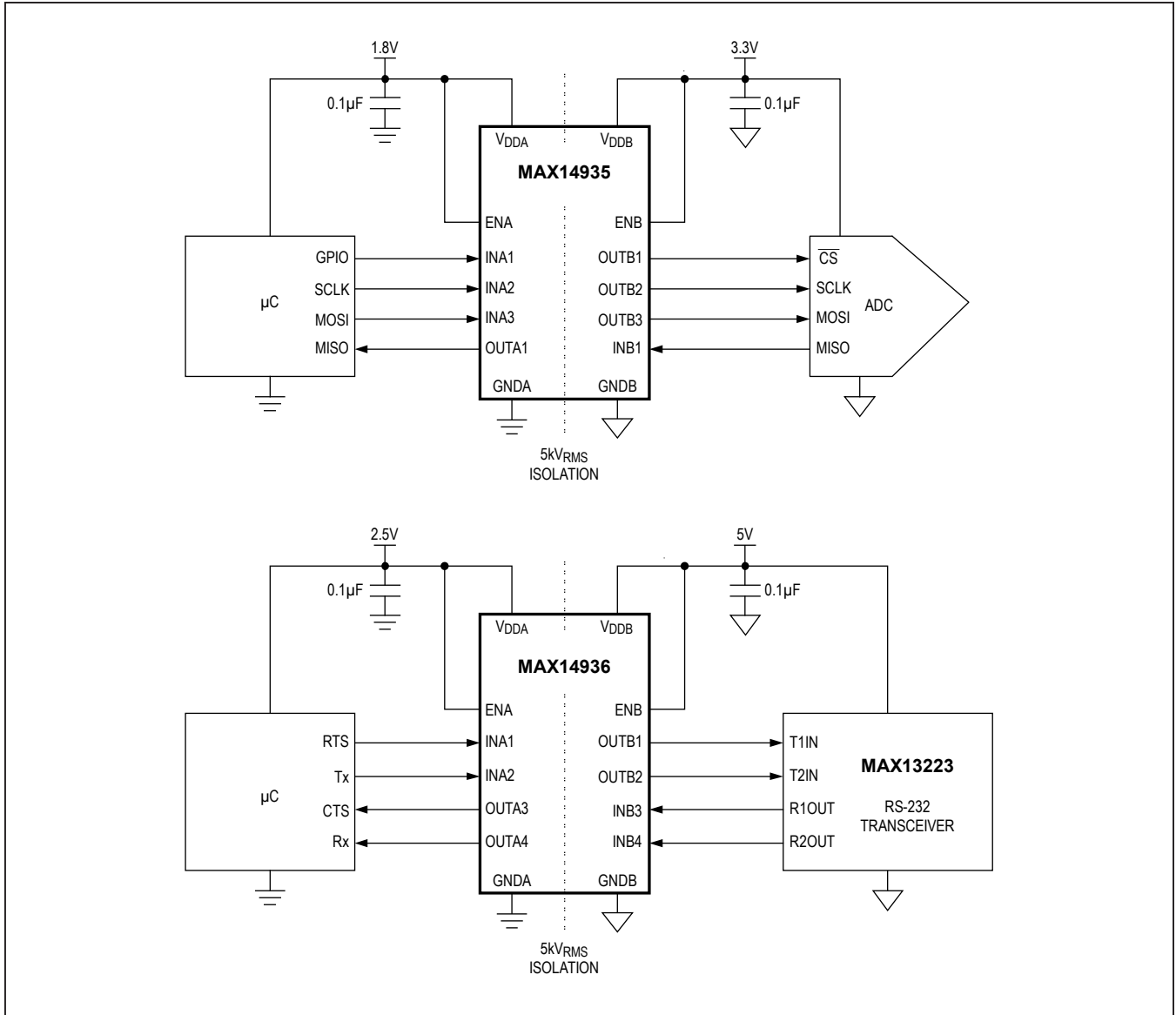

Detailed Description

The MAX14934–MAX14936 are a family of four-channel digital isolators. The MAX14934–MAX14936 family transfers digital signals between circuits with different power domains. The devices are rated for 5kV_{RMS} isolation voltage for 60 seconds. This family of digital isolators offers low-power operation, high electromagnetic interference (EMI) immunity, and stable temperature performance through Maxim's proprietary process technology. The devices isolate different ground domains and block high-voltage/high-current transients from sensitive or human interface circuitry.

The MAX14934–MAX14936 family offers three unidirectional channel configurations for design convenience. The MAX14934 features four channels transferring digital signals in one direction for applications such as isolated digital I/O. The MAX14935 has three channels transmitting data in one direction and one channel transmitting in the opposite direction, making it ideal for applications such as isolated SPI and RS-485 communication. The MAX14936 provides further design flexibility with two channels in each direction for isolated RS-232 or other applications.

Devices are available with data rates from DC up to 1Mbps (A/D versions), 25Mbps (B/E versions), or 150Mbps (C/F versions). Each device can also be ordered with default-high or default-low outputs. This is the state an output will go to when the input side of the device is unpowered.

The devices have two supply inputs, V_{DDA} and V_{ddb}, that independently set the logic levels on either side of the device. V_{DDA} and V_{ddb} are referenced to GNDA and GNDB, respectively. The MAX14934–MAX14936 family also features a refresh circuit to ensure output accuracy when an input remains in the same state indefinitely.

Digital Isolation

The MAX14934–MAX14936 family provides galvanic isolation for digital signals that are transmitted between two ground domains. Up to 1200V_{PEAK} of continuous isolation is supported, as well as transient differences of up to 5kV_{RMS} for up to 60 seconds.

Level Shifting

The wide supply voltage range of both V_{DDA} and V_{ddb} allows the MAX14934–MAX14936 family to be used for level translation in addition to isolation. V_{DDA} and V_{ddb} can be independently set to any voltage from 1.71V to 5.5V. The supply voltage sets the logic level on the corresponding side of the isolator.

Unidirectional Channels

Each channel of the MAX14934–MAX14936 is unidirectional; it only passes data in one direction, as indicated in the functional diagram. Each device features four unidirectional channels that operate independently with guaranteed data rates from DC up to 1Mbps (A/D versions), 25Mbps (B/E versions), or 150Mbps (C/F versions). The output driver of each channel is push-pull, eliminating the need for pullup resistors. The outputs are able to drive both TTL and CMOS logic inputs.

Startup and Undervoltage Lockout

The V_{DDA} and V_{ddb} supplies are both internally monitored for undervoltage conditions. Undervoltage events can occur during power-up, power-down, or during normal operation due to a sagging supply voltage. When an undervoltage condition is detected on either supply, all outputs go to their default states regardless of the status of the inputs (Table 2). Figure 4 through Figure 7 show the behavior of the outputs during power-up and power-down.

Applications Information

Power-Supply Sequencing

The MAX14934–MAX14936 do not require special power-supply sequencing. The logic levels are set independently on either side by V_{DDA} and V_{ddb}. Each supply can be present over the entire specified range regardless of the level or presence of the other supply.

Power-Supply Decoupling

To reduce ripple and the chance of introducing data errors, bypass V_{DDA} and V_{ddb} with 0.1μF ceramic capacitors to GNDA and GNDB, respectively. Place the bypass capacitors as close to the power-supply input pins as possible.

Layout Considerations

The PCB designer should follow some critical recommendations in order to get the best performance from the design.

- Keep the input/output traces as short as possible. To keep signal paths low-inductance, avoid using vias.
- Have a solid ground plane underneath the high-speed signal layer.
- Keep the area underneath the MAX14934–MAX14936 free from ground and signal planes. Any galvanic or metallic connection between the Side A and Side B defeats the isolation.

Table 2. Output Behavior During Undervoltage Conditions

V _{IN}	V _{DDA}	V _{DDB}	ENA	ENB	V _{OUTA}	V _{OUTB}
1	Powered	Powered	1	1	1	1
			0	0	Hi-Z	Hi-Z
0	Powered	Powered	1	1	0	0
			0	0	Hi-Z	Hi-Z
X	Undervoltage	Powered	1	1	Default	Default
			0	0	Hi-Z	Hi-Z
X	Powered	Undervoltage	1	1	Default	Default
			0	0	Hi-Z	Hi-Z

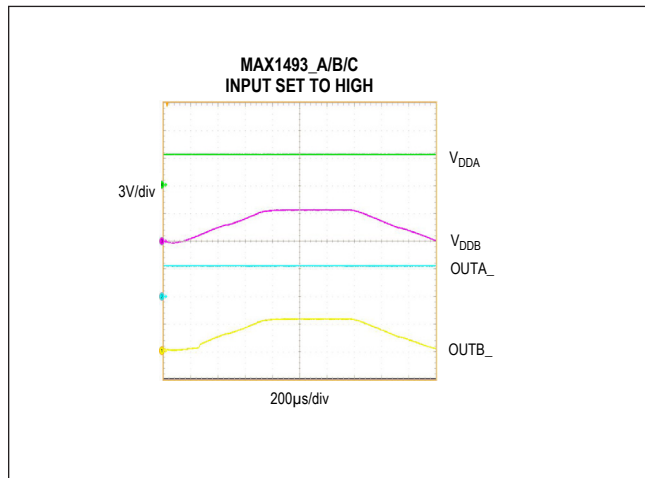

Figure 4. Undervoltage Lockout Behavior (MAX1493_A/B/C High)

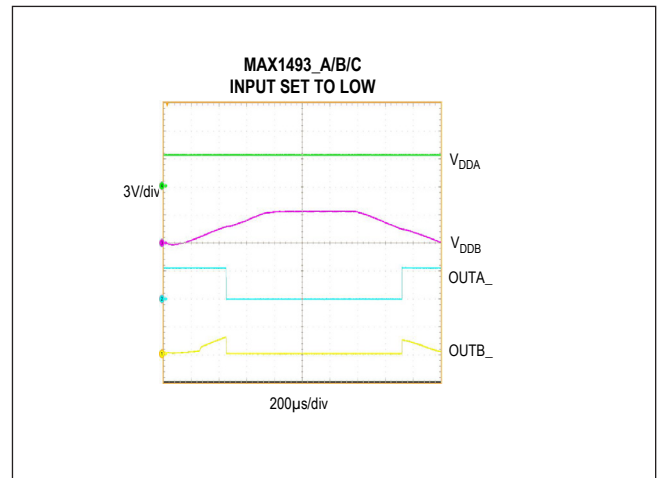

Figure 5. Undervoltage Lockout Behavior (MAX1493_A/B/C Low)

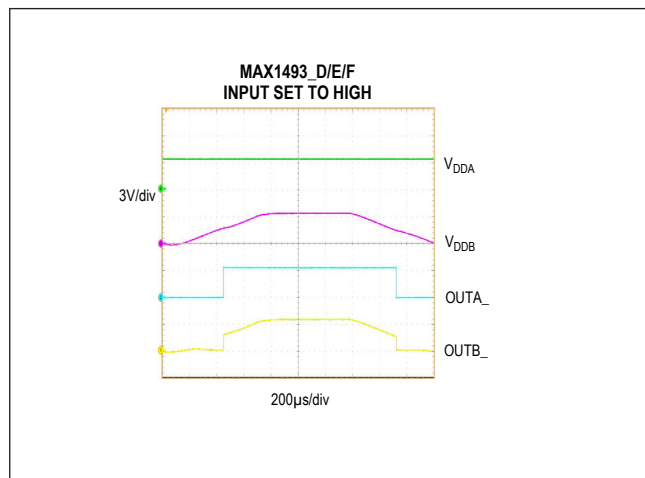

Figure 6. Undervoltage Lockout Behavior (MAX1493_D/E/F High)

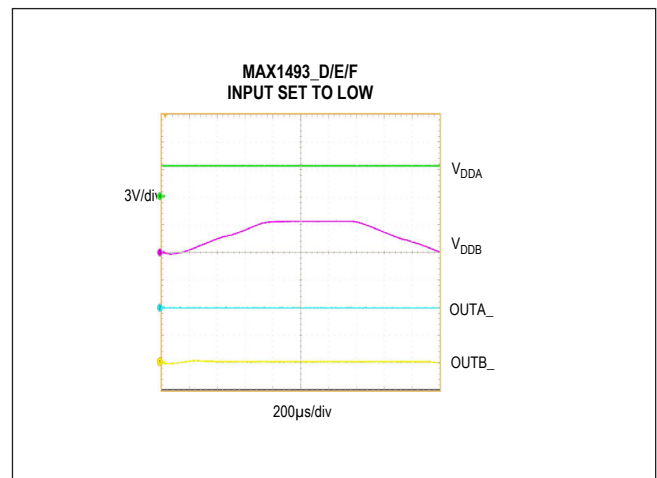

Figure 7. Undervoltage Lockout Behavior (MAX1493_D/E/F Low)

Product Selector Guide

MAX14934 F A W E +

CHANNEL CONFIGURATION
4: 4/0
5: 3/1
6: 2/2

MAXIMUM DATA RATE
DEFAULT OUTPUT (SEE TABLE)

TEMP RANGE: -40°C TO +125°C

PACKAGE: W SOIC

PINS: 16

LEAD-FREE/ROHS COMPLIANT

DEVICE CONFIGURATION	MAX DATA RATE		
	1Mbps	25Mbps	150Mbps
DEFAULT-HIGH OUTPUT	A	B	C
DEFAULT-LOW OUTPUT	D	E	F

Ordering Information

PART	CHANNEL CONFIGURATION	DATA RATE (Mbps)	OUTPUT	TEMP RANGE (°C)	PIN-PACKAGE
MAX14934AAWE+	4/0	1	Default high	-40 to +125	16 wide SOIC
MAX14934BAWE+	4/0	25	Default high	-40 to +125	16 wide SOIC
MAX14934CAWE+	4/0	150	Default high	-40 to +125	16 wide SOIC
MAX14934DAWE+	4/0	1	Default low	-40 to +125	16 wide SOIC
MAX14934EAW+	4/0	25	Default low	-40 to +125	16 wide SOIC
MAX14934FAWE+	4/0	150	Default low	-40 to +125	16 wide SOIC
MAX14935AAWE+	3/1	1	Default high	-40 to +125	16 wide SOIC
MAX14935BAWE+	3/1	25	Default high	-40 to +125	16 wide SOIC
MAX14935CAWE+	3/1	150	Default high	-40 to +125	16 wide SOIC
MAX14935DAWE+	3/1	1	Default low	-40 to +125	16 wide SOIC
MAX14935EAW+	3/1	25	Default low	-40 to +125	16 wide SOIC
MAX14935FAWE+	3/1	150	Default low	-40 to +125	16 wide SOIC
MAX14936AAWE+	2/2	1	Default high	-40 to +125	16 wide SOIC
MAX14936BAWE+	2/2	25	Default high	-40 to +125	16 wide SOIC
MAX14936CAWE+	2/2	150	Default high	-40 to +125	16 wide SOIC
MAX14936DAWE+	2/2	1	Default low	-40 to +125	16 wide SOIC
MAX14936EAW+	2/2	25	Default low	-40 to +125	16 wide SOIC
MAX14936FAWE+	2/2	150	Default low	-40 to +125	16 wide SOIC

+Denotes a lead(Pb)-free/RoHS-compliant package.

Chip Information

PROCESS: BiCMOS

Revision History

REVISION NUMBER	REVISION DATE	DESCRIPTION	PAGES CHANGED
0	9/14	Initial release	—
1	12/14	Removed future product notation from MAX14935DAWE+ in <i>Ordering Information</i> table, changed “basic insulation” to “single protection” in <i>Safety Regulatory Approvals</i> table, and updated third bullet of <i>Many Options Support Broad Applications</i> in <i>Features and Benefits</i> section.	1, 13, 22
2	3/15	Changed future product status for: MAX14934DAWE+, MAX14936AAWE+, MAX14936BAWE+, MAX14936DAWE+, MAX14936EAWWE+, and MAX14936FAWE+.	22
3	7/15	Updated <i>Benefits and Features</i> section, <i>Safety Regulatory Approvals</i> , <i>Insulation Characteristics</i> tables, and <i>Pin Configuration</i> tables.	1, 13, 14, 16
4	4/16	Fixed typos, updated <i>Safety Regulatory Approvals</i> , and updated <i>Ordering Information/ Selection Guide</i> .	1, 13, 14, 21
5	5/16	Updated TUV information and created <i>IEC Insulation Testing</i> table	1, 13
6	1/17	Updated Figure 1 text and removed VDE pending	1, 13, 14
9	11/20	Updated <i>General Description</i> , <i>Dynamic Electrical Characteristics (MAX1493_A/D)</i> , <i>Dynamic Electrical Characteristics (MAX1493_B/E)</i> , <i>Dynamic Electrical Characteristics (MAX1493_C/F)</i> , <i>Safety Regulatory Approvals</i> , <i>Typical Operating Circuits</i> , and <i>Layout Considerations</i> sections; added <i>Safety Limits</i> and <i>Product Selector Guide</i> sections; added new Figures 2 and 3, and renumbered subsequent figures; added Table 1 and renumbered subsequent tables; added a <i>Product Selector Guide</i>	1, 5–10, 14–24

For pricing, delivery, and ordering information, please visit Maxim Integrated's online storefront at <https://www.maximintegrated.com/en/storefront/storefront.html>.

Maxim Integrated cannot assume responsibility for use of any circuitry other than circuitry entirely embodied in a Maxim Integrated product. No circuit patent licenses are implied. Maxim Integrated reserves the right to change the circuitry and specifications without notice at any time. The parametric values (min and max limits) shown in the *Electrical Characteristics* table are guaranteed. Other parametric values quoted in this data sheet are provided for guidance.

Looking for pricing, stock, or lifecycle information?

Click below to explore more details on WIN SOURCE:

 [View MAX14935EAW+ on WIN SOURCE](#)

 [Maxim Integrated](#) Information

Optimize Your Supply Chain with WIN SOURCE Solutions

-  Global Sourcing Solution
-  Obsolete Management
-  Cost Control Management
-  Shortage Management
-  Alternative Solution
-  Excess Inventory Management