



**THE DATASHEET OF  
LT4275BHDD#PBF**



## FEATURES

- IEEE 802.3af/at and LTPoE++™ Powered Device (PD) Controller
- LTPoE++ Supports Power Levels Up to 90W
- LT4275A Supports All of the Following Standards:
  - LTPoE++ 38.7W, 52.7W, 70W and 90W
  - IEEE 802.3at 25.5W Compliant
  - IEEE 802.3af Up to 13W Compliant
- LT4275B is IEEE 802.3at/af Compliant
- LT4275C is IEEE 802.3af Compliant
- 100V Absolute Maximum Input Voltage
- Wide Junction Temperature Range (–40°C to 125°C)
- Overtemperature Protection
- Integrated Signature Resistor
- External Hot Swap™ N-Channel MOSFET for Lowest Power Dissipation and Highest System Efficiency
- Programmable Aux Power Support as Low as 9V
- Optional Support of Non-Standard Low Voltage PoE
- Available in 10-Lead MSOP and 3mm × 3mm DFN Packages

## APPLICATIONS

- High Power Wireless Data Systems
- Outdoor Security Camera Equipment
- Commercial and Public Information Displays
- High Temperature Industrial Applications

## DESCRIPTION

The LT®4275 is a pin-for-pin compatible family of IEEE 802.3 and LTPoE++ powered device (PD) controllers.

The LT4275A employs a proprietary LTPoE++ classification scheme, delivering 38.7W, 52.7W, 70W or 90W of power at the PD RJ45 connector. The LT4275A is fully compatible with IEEE 802.3. The LT4275B is an IEEE 802.3at compliant, Type 2 (PoE+) PD delivering up to 25.5W. The LT4275C is an IEEE 802.3af compliant, Type 1 (PoE) PD delivering up to 13W.

The LT4275 internal charge pump provides an N-channel MOSFET solution, eliminating a larger and more costly P-channel MOSFET. A low  $R_{DS(ON)}$  MOSFET also maximizes power delivery and efficiency, reduces power and heat dissipation, and eases thermal design. Startup inrush current is adjustable with an external capacitor. The LT4275 also includes a power good output, on-board signature resistor, undervoltage lockout, and thermal protection. The LT4275A/LT4275B drives a single opto-coupler to indicate the power level of the attached PSE. Pin-selectable support for non-standard low voltage operation is provided. Auxiliary power override is supported with the AUX pin.

The LT4275A can be configured to support all possible LTPoE++, 802.3at and 802.3af power levels with external component changes.

LT, LT, LTC, LTM, Linear Technology and the Linear logo are registered trademarks and LTPoE++ and Hot Swap are trademarks of Linear Technology Corporation. All other trademarks are the property of their respective owners.

## TYPICAL APPLICATION

LTPoE++ 90W Powered Device Interface

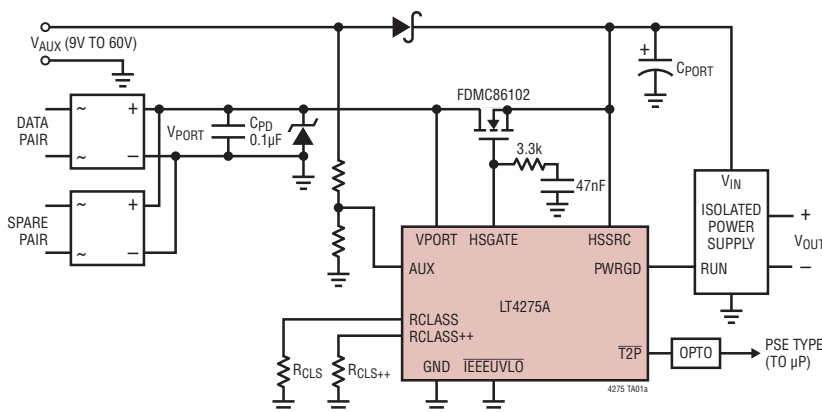

LT4275 Family

| MAX DELIVERED POWER | LT4275 GRADE |   |   |
|---------------------|--------------|---|---|
|                     | A            | B | C |
| LTPoE++ 90W         | ●            |   |   |
| LTPoE++ 70W         | ●            |   |   |
| LTPoE++ 52.7W       | ●            |   |   |
| LTPoE++ 38.7W       | ●            |   |   |
| 25.5W               | ●            | ● |   |
| 13W                 | ●            | ● | ● |

# LT4275

## ABSOLUTE MAXIMUM RATINGS

(Notes 1, 3)

VPORT, HSSRC Voltages ..... -0.3V to 100V  
 HSGATE Current..... ±20mA  
 IEEUUVLO, RCLASS,  
 RCLASS++ Voltages ..... -0.3V to 8V (and ≤ VPORT)  
 AUX Current..... ±1.4mA  
 T2P, PWRGD Voltage ..... -0.3V to 100V  
 T2P, PWRGD Current .....5mA

Operating Junction Temperature Range (Note 4)  
 LT4275AI/LT4275BI/LT4275CI..... -40°C to 85°C  
 LT4275AH/LT4275BH/LT4275CH ..... -40°C to 125°C  
 Storage Temperature Range ..... -65°C to 150°C  
 Lead Temperature (Soldering, 10 sec.)..... 300°C

## PIN CONFIGURATION

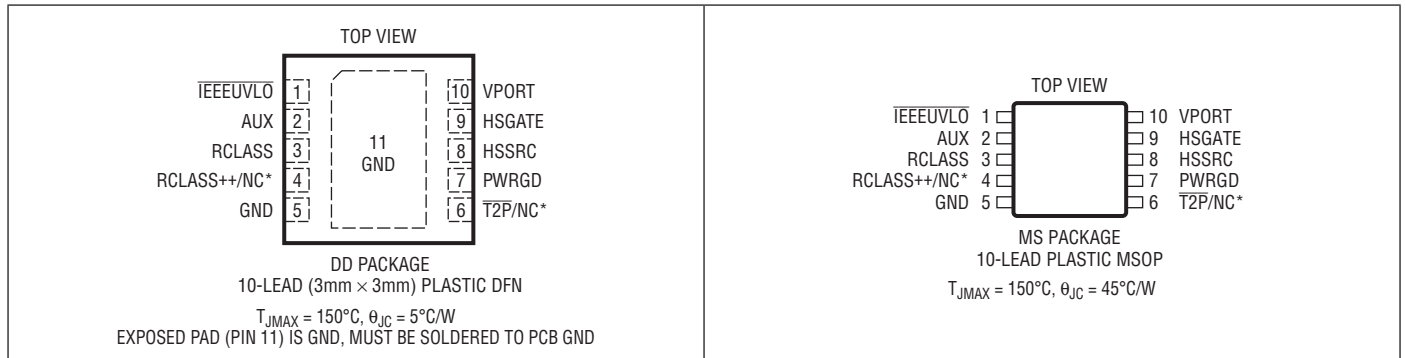

\* RCLASS++ is not connected in the LT4275B/C versions. T2P is not connected in the LT4275C version.

## ORDER INFORMATION

| LEAD FREE FINISH | TAPE AND REEL    | PART MARKING* | MAX PD POWER | PACKAGE DESCRIPTION             | TEMPERATURE RANGE |
|------------------|------------------|---------------|--------------|---------------------------------|-------------------|
| LT4275AIDD#PBF   | LT4275AIDD#TRPBF | LGBS          | 90W          | 10-Lead (3mm × 3mm) Plastic DFN | -40°C to 85°C     |
| LT4275AHDD#PBF   | LT4275AHDD#TRPBF | LGBS          | 90W          | 10-Lead (3mm × 3mm) Plastic DFN | -40°C to 125°C    |
| LT4275AIMS#PBF   | LT4275AIMS#TRPBF | LTGBT         | 90W          | 10-Lead Plastic MSOP            | -40°C to 85°C     |
| LT4275AHMS#PBF   | LT4275AHMS#TRPBF | LTGBT         | 90W          | 10-Lead Plastic MSOP            | -40°C to 125°C    |
| LT4275BIDD#PBF   | LT4275BIDD#TRPBF | LGBV          | 25.5W        | 10-Lead (3mm × 3mm) Plastic DFN | -40°C to 85°C     |
| LT4275BHDD#PBF   | LT4275BHDD#TRPBF | LGBV          | 25.5W        | 10-Lead (3mm × 3mm) Plastic DFN | -40°C to 125°C    |
| LT4275BIMS#PBF   | LT4275BIMS#TRPBF | LTGBW         | 25.5W        | 10-Lead Plastic MSOP            | -40°C to 85°C     |
| LT4275BHMS#PBF   | LT4275BHMS#TRPBF | LTGBW         | 25.5W        | 10-Lead Plastic MSOP            | -40°C to 125°C    |
| LT4275CIDD#PBF   | LT4275CIDD#TRPBF | LGBX          | 13W          | 10-Lead (3mm × 3mm) Plastic DFN | -40°C to 85°C     |
| LT4275CHDD#PBF   | LT4275CHDD#TRPBF | LGBX          | 13W          | 10-Lead (3mm × 3mm) Plastic DFN | -40°C to 125°C    |
| LT4275CIMS#PBF   | LT4275CIMS#TRPBF | LTGBY         | 13W          | 10-Lead Plastic MSOP            | -40°C to 85°C     |
| LT4275CHMS#PBF   | LT4275CHMS#TRPBF | LTGBY         | 13W          | 10-Lead Plastic MSOP            | -40°C to 125°C    |

Consult LTC Marketing for parts specified with wider operating temperature ranges. \*The temperature grade is identified by a label on the shipping container. Consult LTC Marketing for information on nonstandard lead based finish parts.

For more information on lead free part marking, go to: <http://www.linear.com/leadfree/>

For more information on tape and reel specifications, go to: <http://www.linear.com/tapeandree/>

**ELECTRICAL CHARACTERISTICS** The ● denotes the specifications which apply over the full operating temperature range, otherwise specifications are at T<sub>A</sub> = 25°C. (Note 3)

| SYMBOL             | PARAMETER                         | CONDITIONS   |        | MIN        | TYP        | MAX      | UNITS  |
|--------------------|-----------------------------------|--|--------|------------|------------|----------|--------|
|                    | VPORT Operating Input Voltage     | At VPORT Pin   | ●      | 23         |            | 60       | V      |
| V <sub>SIG</sub>   | VPORT Signature Range             | At VPORT Pin   | ●      | 1.5        |            | 10       | V      |
| V <sub>CLASS</sub> | VPORT Classification Range        | At VPORT Pin   | ●      | 12.5       |            | 21       | V      |
| V <sub>MARK</sub>  | VPORT Mark Range                  | At VPORT Pin, Preceded by V <sub>CLASS</sub>                                     | ●      | 5.6        |            | 10       | V      |
|                    | VPORT Aux Mode Range              | At VPORT Pin, AUX > V <sub>AUXT</sub>  | ●      | 8          |            | 60       | V      |
|                    | Signature/Class Hysteresis Window |  | ●      | 1.0        |            |          | V      |
| V <sub>RESET</sub> | Reset Threshold                   |  | ●      | 2.6        |            | 5.6      | V      |
| V <sub>HSON</sub>  | Hot Swap Turn-On Voltage          | $\overline{I}EEEEUVL\overline{O} = 0V$<br>$\overline{I}EEEEUVL\overline{O}$ Open | ●<br>● |            | 35<br>27   | 37<br>29 | V<br>V |
| V <sub>HSOFF</sub> | Hot Swap Turn-Off Voltage         | $\overline{I}EEEEUVL\overline{O} = 0V$<br>$\overline{I}EEEEUVL\overline{O}$ Open | ●<br>● | 30<br>21.5 | 31<br>22.5 |          | V<br>V |
|                    | Hot Swap On/Off Hysteresis Window |  | ●      | 3          |            |          | V      |

**Supply Current**

|  |                                      |   |   |     |     |     |    |
|--|--------------------------------------|---|---|-----|-----|-----|----|
|  | Supply Current                       | VPORT = HSSRC = 57V                     | ● |     |     | 2   | mA |
|  | Supply Current During Classification | VPORT = 17.5V, RCLASS and RCLASS++ Open | ● | 0.4 | 0.7 | 1.1 | mA |
|  | Supply Current During Mark Event     | V <sub>MARK</sub>                       | ● | 0.5 |     | 2.2 | mA |

**Signature and Classification**

|                   |  |   |   |      |      |      |    |
|-------------------|--|---|---|------|------|------|----|
|                   | Signature Resistance                   | V <sub>SIG</sub> (Note 2)                               | ● | 23.7 | 24.4 | 25.2 | kΩ |
|                   | Signature Resistance During Mark Event | V <sub>MARK</sub> (Note 2)                              | ● | 5.8  | 8.3  | 11   | kΩ |
| V <sub>RCLS</sub> | RCLASS/RCLASS++ Operating Voltage      | -10mA ≥ I <sub>RCLASS</sub> ≥ -36mA, V <sub>CLASS</sub> | ● | 1.32 | 1.40 | 1.43 | V  |
|                   | Classification Stability Time          | VPORT Step to 17.5V, RCLASS = 34.8Ω                     | ● |      |      | 2    | ms |

**Analog/Digital Interface**

|                   |                                 |                                 |   |     |     |     |    |
|-------------------|---------------------------------|---------------------------------|---|-----|-----|-----|----|
| V <sub>AUXT</sub> | AUX Threshold                   |                                 | ● | 6.1 | 6.3 | 6.5 | V  |
| I <sub>AUXH</sub> | AUX Pin Hysteresis Current      | AUX = 6.1V                      | ● | 4   | 5.8 | 8   | μA |
|                   | T <sub>2P</sub> Output Low      | 1mA Load (LT4275A/LT4275B Only) | ● |     |     | 0.8 | V  |
|                   | PWRGD Output Low                | 1mA Load                        | ● |     |     | 0.8 | V  |
|                   | PWRGD Leakage Current           | PWRGD = 60V                     | ● |     |     | 5   | μA |
|                   | T <sub>2P</sub> Leakage Current | T <sub>2P</sub> = 60V           | ● |     |     | 5   | μA |

**Hot Swap Control**

|                  |                             |  |   |     |    |    |    |
|------------------|-----------------------------|--|---|-----|----|----|----|
| I <sub>GPU</sub> | HSGATE Pull-Up Current      | V <sub>HSGATE</sub> - V <sub>HSSRC</sub> = 5V, V <sub>PORT</sub> > 42V, Out of Pin | ● | 18  | 22 | 27 | μA |
| V <sub>GOC</sub> | HSGATE Open Circuit Voltage | V <sub>HSGATE</sub> - V <sub>HSSRC</sub> , 0μA to 10μA Load with Respect to HSSRC  | ● | 10  |    | 18 | V  |
|                  | HSGATE Pull-Down Current    | V <sub>HSGATE</sub> - V <sub>HSSRC</sub> = 5V                                      | ● | 200 |    |    | μA |

**Timing**

|                  |                           |  |   |     |     |     |    |
|------------------|---------------------------|--|---|-----|-----|-----|----|
| f <sub>T2P</sub> | T <sub>2P</sub> Frequency | After PWRGD Valid, if LTPoE++ PSE Is Mutually Identified | ● | 690 | 840 | 990 | Hz |
|------------------|---------------------------|--|---|-----|-----|-----|----|

**Note 1:** Stresses beyond those listed under Absolute Maximum Ratings may cause permanent damage to the device. Exposure to any Absolute Maximum Rating condition for extended periods may affect device reliability and lifetime.

**Note 2:** Signature resistance specifications do not include resistance added by the external diode bridge which can add as much as 1.1k to the port resistance.

**Note 3:** All voltages with respect to GND unless otherwise noted. Positive currents are into pins; negative currents are out of pins unless otherwise noted.

**Note 4:** This IC includes overtemperature protection that is intended to protect the device during momentary overload conditions. Junction temperature will exceed 150°C when overtemperature protection is active. Continuous operation above the specified maximum operating junction temperature may impair device reliability.

# TYPICAL PERFORMANCE CHARACTERISTICS

**VPORT Current vs VPORT Voltage  
25k Detection Range**

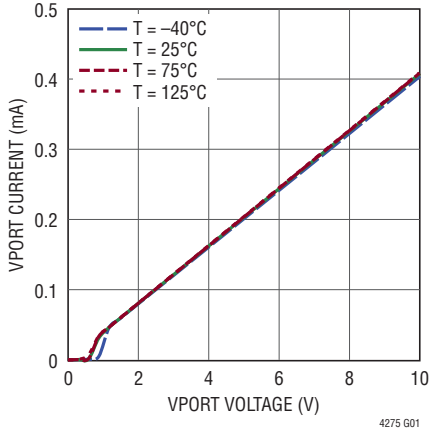

**VPORT Hot Swap Thresholds**

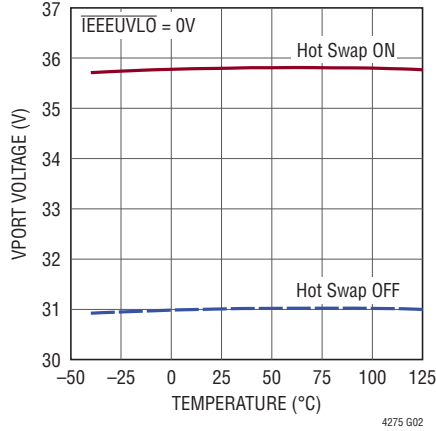

**Supply Current During Power-On**

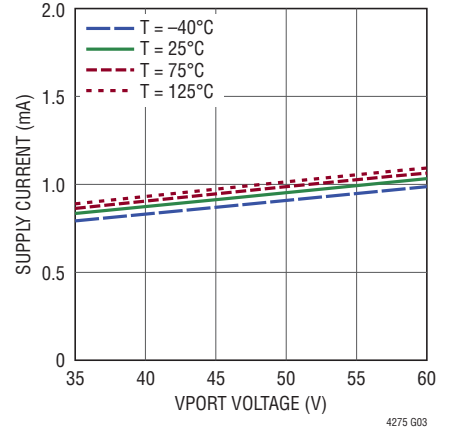

**Signature Resistance vs Input Voltage**

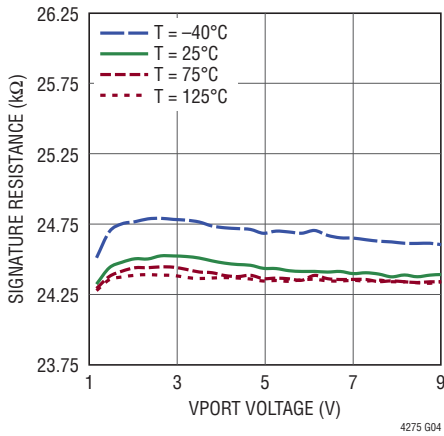

**VPORT Hot Swap Thresholds**

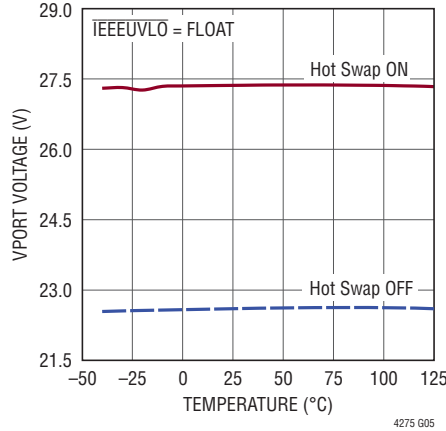

**Reset Threshold**

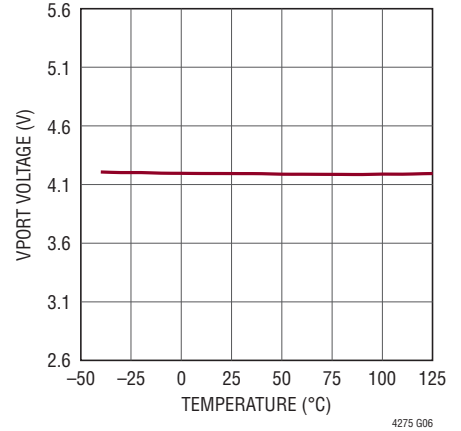

**PWRGD, T2P Output Low  
Voltage vs Current**

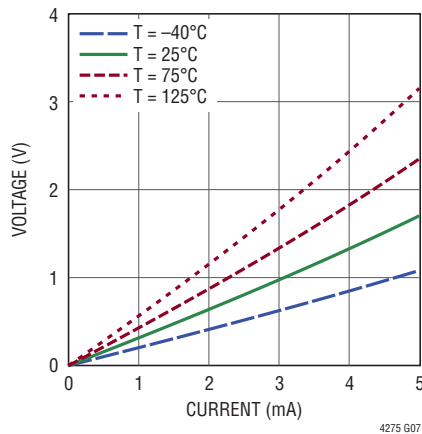

**VPORT Classification Thresholds**

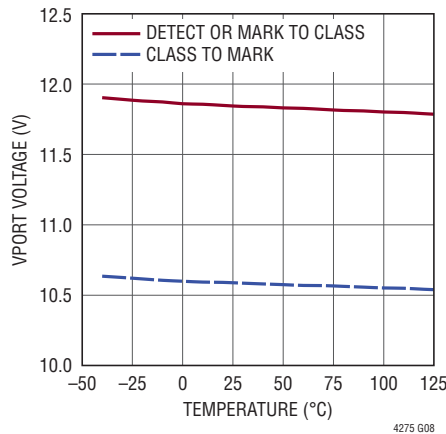

**T2P Frequency**

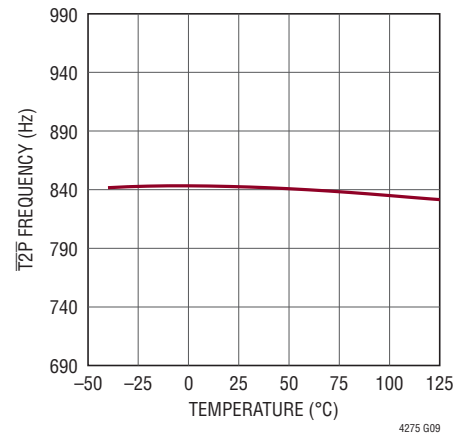

## PIN FUNCTIONS

**IEEEUVLO (Pin 1):** Hot Swap Turn-on Threshold Level Control. Connect to ground for IEEE compliant turn-on and turn-off (UVLO) voltage thresholds. Leave open for lower turn-on and turn-off voltage thresholds.

**AUX (Pin 2):** Auxiliary Sense. Assert AUX via a resistive divider from the auxiliary power input to set the voltage at which the auxiliary supply takes over. Asserting AUX pulls down HSGATE, disconnects the signature resistor, disables classification and floats the PWRGD pin. The AUX pin sinks  $I_{AUXH}$  when below its threshold voltage of  $V_{AUXT}$  to provide hysteresis. Tie to GND when not used.

**RCLASS (Pin 3):** Programmable PoE Classification Resistor. See Table 1.

**RCLASS++ (Pin 4, LT4275A Only):** Programmable LTPoE++ Classification Resistor. This pin is not connected on the LT4275B/LT4275C. See Table 1.

**GND (Pin 5):** Ground Pin. Must be soldered to PCB GND.

**T2P (Pin 6, LT4275A/LT4275B Only):** PSE Type Indicator, Open-Drain Output.  $\overline{T2P}$  floats for a 13W PSE.  $\overline{T2P}$  pulls down for a 25.5W PSE.  $\overline{T2P}$  pulls down at  $f_{T2P}$  with a 50% (typical) duty cycle to indicate the presence of an LTPoE++ PSE.  $\overline{T2P}$  is valid after PWRGD is active. This pin is not connected on the LT4275C. See the Applications Information section for behavior when using the AUX pin.

**PWRGD (Pin 7):** Power Good Indicator, Open-Drain Output. Pulls down during  $V_{CLASS}$  and inrush.

**HSSRC (Pin 8):** External Hot Swap MOSFET Source. Connect to source of the external MOSFET.

**HSGATE (Pin 9):** External Hot Swap MOSFET Gate Control, Output. Connect to gate of the external MOSFET.

**VPORT (Pin 10):** PD interface upper power rail and external Hot Swap MOSFET drain connection.

**Exposed Pad (Pin 11, DFN Package Only):** GND. Must be soldered to PCB GND.

## BLOCK DIAGRAM

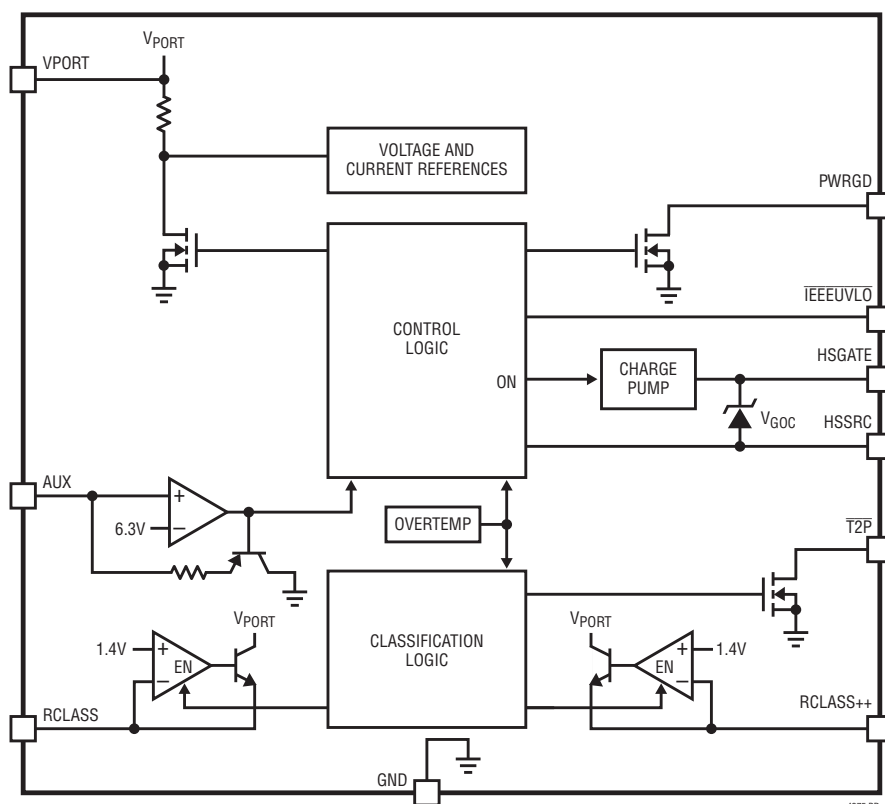

## APPLICATIONS INFORMATION

### OVERVIEW

Power over Ethernet (PoE) continues to gain popularity as products take advantage of DC power and high speed data available from a single RJ45 connector. Powered device (PD) equipment vendors are running into the 25.5W power limit established by the IEEE 802.3 standard. The LT4275A allows higher power while maintaining backwards compatibility with existing PSE systems. The LT4275 utilizes a low  $R_{DS(ON)}$  N-channel MOSFET to maximize efficiency and delivered power. Heat is also reduced, easing thermal design.

### MODES OF OPERATION

The LT4275 has several modes of operation depending on the input voltage sequence applied to the VPORT pin. These modes include 25k $\Omega$  signature detection, classification, mark, inrush and powered on.

### DETECTION

During detection, the PSE looks for a 25k $\Omega$  signature resistor which identifies the device as a PD. The PSE will apply two voltages in the range of 2.8V to 10V and measure the corresponding currents. Figure 1 shows the detection voltages. The PSE calculates the signature resistance using a  $\Delta V/\Delta I$  measurement technique.

The LT4275 presents its precision, temperature-compensated 24.4k resistor between the VPORT and GND pins, allowing the PSE to recognize a PD is present and requesting power to be applied. The LT4275 signature resistor is smaller than 25k to compensate for the additional series resistance introduced by the IEEE required bridge.

### CLASSIFICATION

The detection/classification process varies depending on whether the PSE is Type 1, Type 2, or LTPoE++. A Type 2 PSE may use Type 1 classification signaling and later renegotiate a higher power classification with the PD over the data layer.

A Type 1 PSE, after a successful detection, may apply a classification probe voltage of 15.5V to 20.5V and measure current.

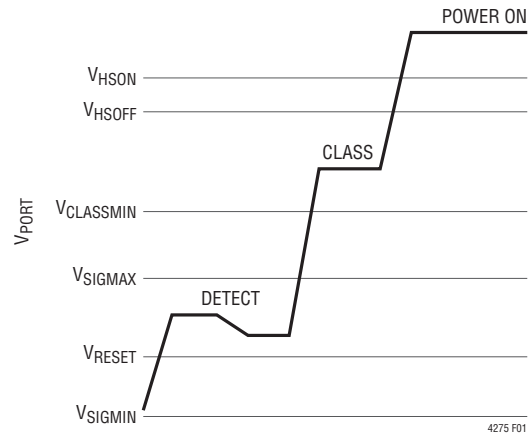

Figure 1. Type 1 Detect/Class Signaling Waveform

A Type 2 PSE may declare the availability of high power by performing 2-event (Physical Layer) classification or by communicating over the (Data Link Layer) high speed data line. A Type 2 PD must recognize both types of communication. Since Layer 2 communications takes place directly between the PSE and the PD application, the LT4275A/LT4275B responsibility ends with supporting 2-event classification.

In 2-event classification, a Type 2 PSE probes for power classification twice as shown in Figure 2. The LT4275A or LT4275B recognizes this and pulls the  $\overline{T2P}$  pin down to signal the load that Type 2 power is available. If an LT4275A senses an LTPoE++ PSE it alternates between pulling  $\overline{T2P}$  down and floating  $\overline{T2P}$  at a rate of  $f_{T2P}$ .

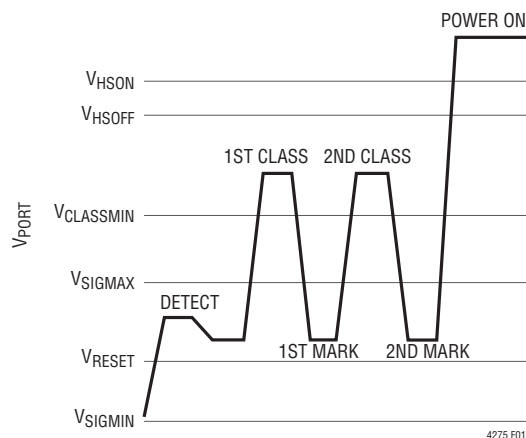

Figure 2. Type 2 Detect/Class Signaling Waveform

## APPLICATIONS INFORMATION

Table 1. Classification Codes, Power Levels and Resistor Selection

| CLASS | PD POWER AVAILABLE | PD TYPE | NOMINAL CLASS CURRENT | LT4275 GRADE CAPABILITY |   |   | RESISTOR         |                                |
|-------|--------------------|---------|-----------------------|-------------------------|---|---|------------------|--------------------------------|
|       |                    |         |                       | A                       | B | C | R <sub>CLS</sub> | R <sub>CLS</sub> <sup>++</sup> |
| 0     | 13W                | Type 1  | <0.4mA                | ✓                       | ✓ | ✓ | Open             | Open                           |
| 1     | 3.84W              | Type 1  | 10.5mA                | ✓                       | ✓ | ✓ | 140Ω             | Open                           |
| 2     | 6.49W              | Type 1  | 18.5mA                | ✓                       | ✓ | ✓ | 76.8Ω            | Open                           |
| 3     | 13W                | Type 1  | 28mA                  | ✓                       | ✓ | ✓ | 49.9Ω            | Open                           |
| 4     | 25.5W              | Type 2  | 40mA                  | ✓                       | ✓ |   | 34.8Ω            | Open                           |
| 4*    | 38.7W              | LTPoE++ | 40mA                  | ✓                       |   |   | Open             | 34.8Ω                          |
| 4*    | 52.7W              | LTPoE++ | 40mA                  | ✓                       |   |   | 140Ω             | 46.4Ω                          |
| 4*    | 70W                | LTPoE++ | 40mA                  | ✓                       |   |   | 76.8Ω            | 64.9Ω                          |
| 4*    | 90W                | LTPoE++ | 40mA                  | ✓                       |   |   | 49.9Ω            | 118Ω                           |

\*An LTPoE++ PD will be classified as class 4 by an IEEE 802.3 compliant PSE.

### LTPoE++ CLASSIFICATION

The LT4275A allows higher power allocation while maintaining backwards compatibility with existing PSE systems by extending the classification signaling of IEEE 802.3. Linear Technology PSE controllers that are capable of LTPoE++ are listed in the Related Parts section. IEEE PSEs will classify an LTPoE++ PD as a Type 2 PD.

### SIGNATURE CORRUPT DURING MARK

During the mark state, the LT4275 presents <11kΩ to the port as required by the IEEE specification.

### INRUSH AND POWERED ON

Once the PSE detects and optionally classifies the PD, the PSE then powers on the PD. When the port voltage rises above the V<sub>HSON</sub> threshold, it begins to source I<sub>GPU</sub> out of the HSGATE pin. This current flows into an external capacitor (C<sub>GATE</sub> in Figure 3) that causes a voltage to ramp up the gate of the external MOSFET. The external MOSFET acts as a source follower and ramps the voltage up on the output bulk capacitor (C<sub>PORT</sub> in Figure 3) thereby determining the inrush current (I<sub>INRUSH</sub> in Figure 3).

To meet IEEE requirements, design I<sub>INRUSH</sub> to be approximately 100mA. See equation below:

$$I_{INRUSH} = I_{GPU} \cdot \frac{C_{PORT}}{C_{GATE}}$$

The LT4275 internal charge pump provides an N-channel MOSFET solution, eliminating a larger and more costly P-channel FET. The low R<sub>DS(ON)</sub> MOSFET also maximizes

power delivery and efficiency, reduces power and heat dissipation, and eases thermal design.

The PWRGD pin is held low by its open drain output until HSGATE charges up to approximately 7V above HSSRC. The PWRGD pin is used to hold off the isolated power supply until inrush is complete and the external MOSFET is fully enhanced. The HSGATE pin will remain high and the PWRGD pin pulled down until the port voltage falls below V<sub>HSSOFF</sub> or the AUX pin is above V<sub>AUXT</sub>.

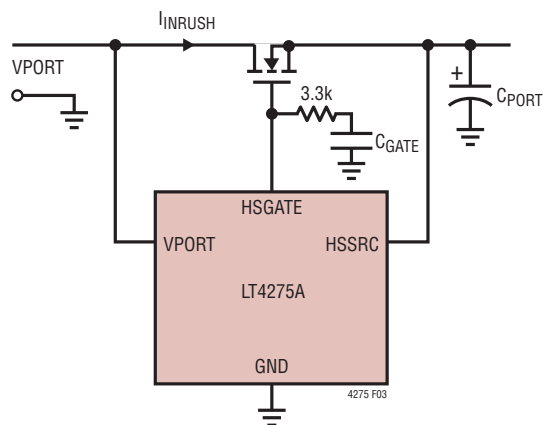

Figure 3. Programming I<sub>INRUSH</sub>

### AUXILIARY SUPPLY OVERRIDE

If the AUX pin is held above V<sub>AUXT</sub>, the LT4275 enters auxiliary power supply override mode. In this mode the signature resistor is disconnected, classification is disabled, HSGATE is pulled down, and the PWRGD pin is allowed to float. The T<sub>2P</sub> pin pulls down on the LT4275A/LT4275B when no R<sub>CLS</sub><sup>++</sup> resistor is present. The T<sub>2P</sub> pin alternates between pulling down and floating at f<sub>T2P</sub> on the LT4275A when the R<sub>CLS</sub><sup>++</sup> resistor is present.

## APPLICATIONS INFORMATION

The AUX pin allows for setting the auxiliary supply turn on ( $V_{AUXON}$ ) and turn off ( $V_{AUXOFF}$ ) voltage thresholds. The auxiliary supply hysteresis voltage ( $V_{AUXHYS}$ ) is set by sinking current ( $I_{AUXH}$ ) only when the AUX pin voltage is less than  $V_{AUXT}$ . Use the following equations to set  $V_{AUXON}$  and  $V_{AUXOFF}$  via R1 and R2 in Figure 4.

$$R1 = \frac{V_{AUXON} - V_{AUXOFF}}{I_{AUXH}} = \frac{V_{AUXHYS}}{I_{AUXH}}$$

$$R2 = \frac{R1}{\left(\frac{V_{AUXOFF}}{V_{AUXT}} - 1\right)}$$

$$R1 \geq \frac{V_{AUX(MAX)} - V_{AUXT}}{1.4mA}$$

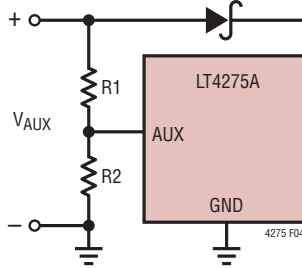

**Figure 4. AUX Threshold and Hysteresis Calculation**

### THERMAL PROTECTION

The IEEE 802.3 specification requires a PD to withstand any applied voltage from 0V to 57V indefinitely. During classification, however, the power dissipation in the LT4275 may be as high as 1.5W. The LT4275 can easily tolerate this power for the maximum IEEE timing but will overheat if this condition persists abnormally.

The LT4275 includes a thermal protection feature which protects itself from excessive heating. If the junction temperature exceeds the overtemperature threshold, the LT4275 pulls down the HSGATE and PWRGD pins and disables classification.

### EXTERNAL INTERFACE AND COMPONENT SELECTION

#### Input Diode Bridge

The input diode bridge introduces a voltage drop that affects the voltage range for each mode of operation. The LT4275 is designed to tolerate these voltage drops. The voltages shown in the Electrical Specifications are measured at the LT4275 package pins.

#### Input Capacitor

A 0.1μF capacitor is needed from VPORT to GND to meet an input impedance requirement in IEEE 802.3.

### Transient Voltage Suppressor

The LT4275 specifies an absolute maximum voltage of 100V and is designed to tolerate brief overvoltage events. However, the pins that interface to the outside world can routinely see excessive peak voltages. To protect the LT4275, install a unidirectional transient voltage suppressor (TVS) such as an SMAJ58A between the port voltage and GND. This TVS must be mounted near the LT4275.

For extremely high cable discharge and surge protection contact Linear Technology Applications.

### Classification Resistor ( $R_{CLS}$ and $R_{CLS++}$ )

The  $R_{CLS}$  resistors set the classification load current corresponding to the PD power classification. Select the value of  $R_{CLS}$  from Table 1 and connect the resistor between the RCLASS pin and GND, or float the RCLASS pin if class 0 is required. The resistor tolerance must be 1% or better to avoid degrading the overall accuracy of the classification circuit. For LTPoE++ use the LT4275A and select the value of  $R_{CLS++}$  from Table 1 in addition to  $R_{CLS}$ .

### Power Good Interface

The LT4275 provides a power good signal (PWRGD) to simplify the isolated power supply design. The power good signal is used to delay isolated power supply startup until the  $C_{PORT}$  capacitor is fully charged.

### Exposed Pad

The LT4275A/LT4275B/LT4275C DFN package has an exposed pad that is internally electrically connected to GND. The exposed pad may only be connected to GND on the printed circuit board.

### LAYOUT CONSIDERATIONS

Avoid excessive parasitic capacitance on the RCLASS pin and place resistor  $R_{CLS}$  close to the LT4275. For the LT4275A, place  $R_{CLS++}$  nearby as well.

It is strictly required for maximum protection to place the input capacitor ( $C_{PD}$ ) and transient voltage suppressor as close to the LT4275 as possible.

TYPICAL APPLICATIONS

IEEE 802.3af (Type 1) 13W Powered Device

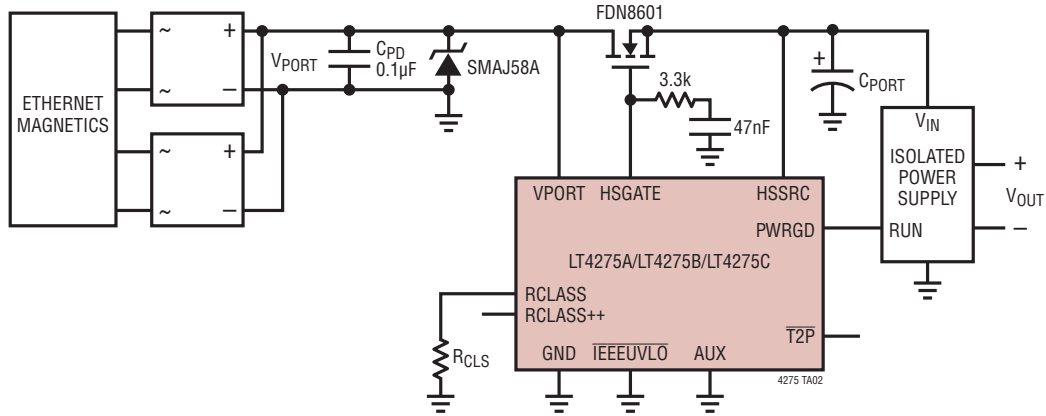

IEEE 802.3at (Type 2) 25.5W Powered Device

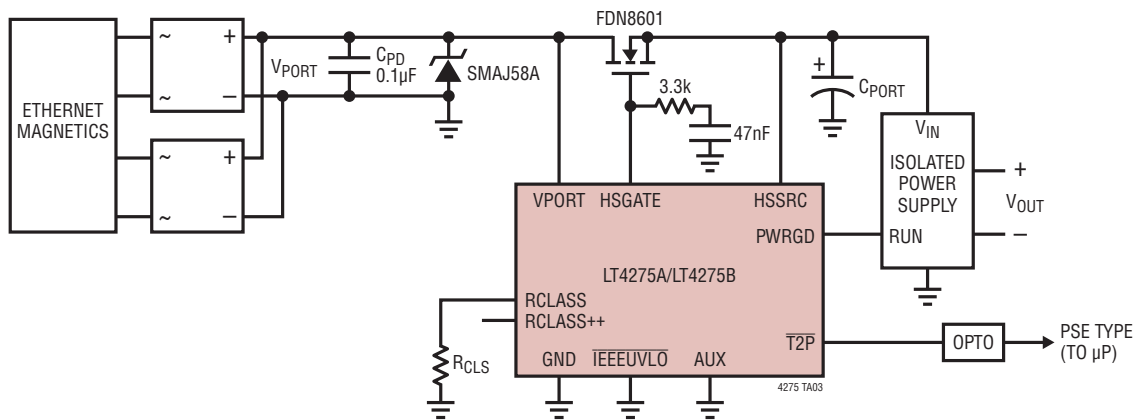

LTPoE++ 38.7W to 90W Powered Device

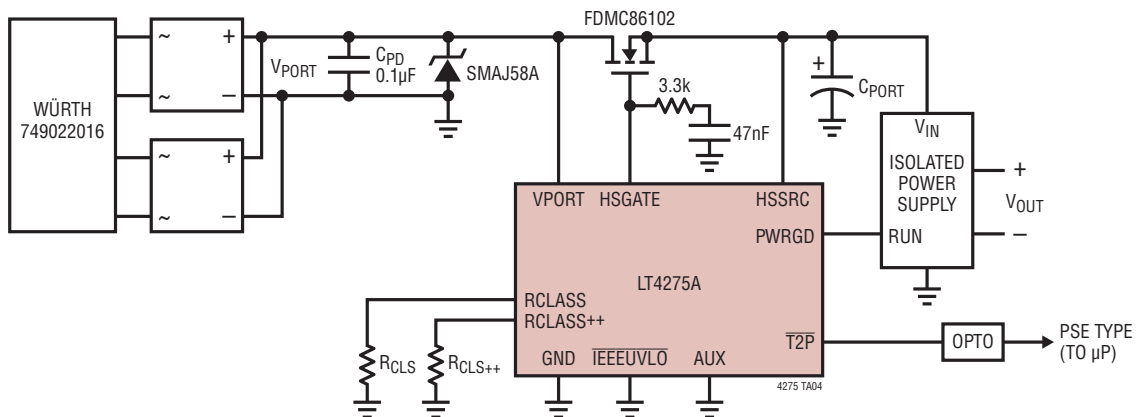

# PACKAGE DESCRIPTION

Please refer to <http://www.linear.com/designtools/packaging/> for the most recent package drawings.

**DD Package**  
**10-Lead Plastic DFN (3mm × 3mm)**  
 (Reference LTC DWG # 05-08-1699 Rev C)

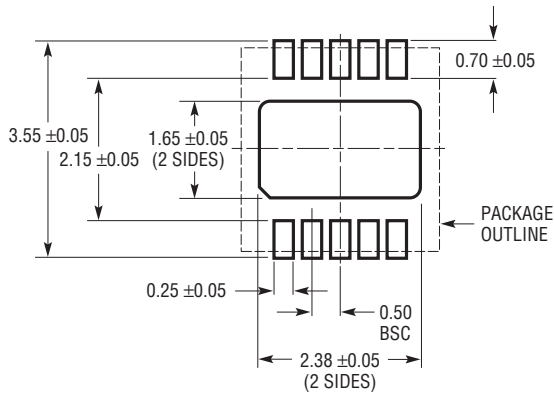

**RECOMMENDED SOLDER PAD PITCH AND DIMENSIONS**

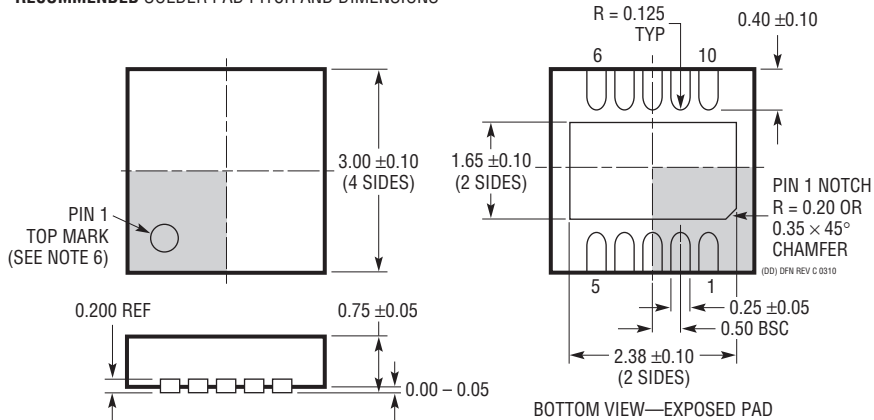

**NOTE:**

1. DRAWING TO BE MADE A JEDEC PACKAGE OUTLINE MO-229 VARIATION OF (WEED-2). CHECK THE LTC WEBSITE DATA SHEET FOR CURRENT STATUS OF VARIATION ASSIGNMENT
2. DRAWING NOT TO SCALE
3. ALL DIMENSIONS ARE IN MILLIMETERS
4. DIMENSIONS OF EXPOSED PAD ON BOTTOM OF PACKAGE DO NOT INCLUDE MOLD FLASH. MOLD FLASH, IF PRESENT, SHALL NOT EXCEED 0.15mm ON ANY SIDE
5. EXPOSED PAD SHALL BE SOLDER PLATED
6. SHADED AREA IS ONLY A REFERENCE FOR PIN 1 LOCATION ON THE TOP AND BOTTOM OF PACKAGE

# PACKAGE DESCRIPTION

Please refer to <http://www.linear.com/designtools/packaging/> for the most recent package drawings.

## MS Package 10-Lead Plastic MSOP (Reference LTC DWG # 05-08-1661 Rev E)

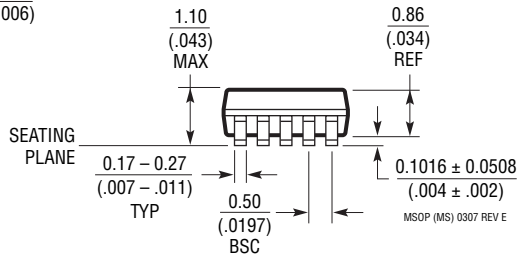
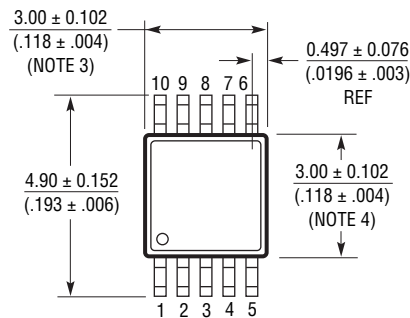
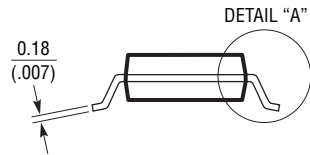
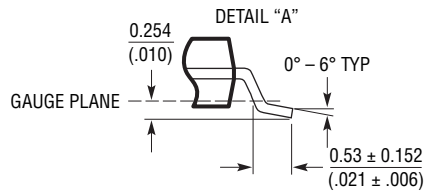
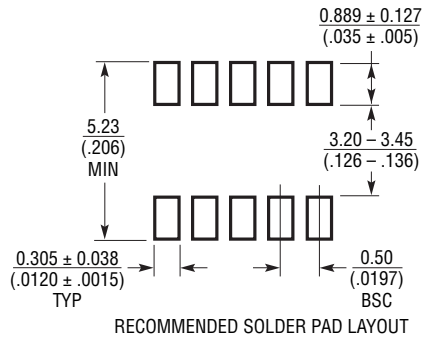

NOTE:

1. DIMENSIONS IN MILLIMETER/(INCH)
2. DRAWING NOT TO SCALE
3. DIMENSION DOES NOT INCLUDE MOLD FLASH, PROTRUSIONS OR GATE BURRS.  
MOLD FLASH, PROTRUSIONS OR GATE BURRS SHALL NOT EXCEED 0.152mm (.006") PER SIDE
4. DIMENSION DOES NOT INCLUDE INTERLEAD FLASH OR PROTRUSIONS.  
INTERLEAD FLASH OR PROTRUSIONS SHALL NOT EXCEED 0.152mm (.006") PER SIDE
5. LEAD COPLANARITY (BOTTOM OF LEADS AFTER FORMING) SHALL BE 0.102mm (.004") MAX

## TYPICAL APPLICATION

### 25W PD Solution with 12VDC and 24VAC Auxiliary Input

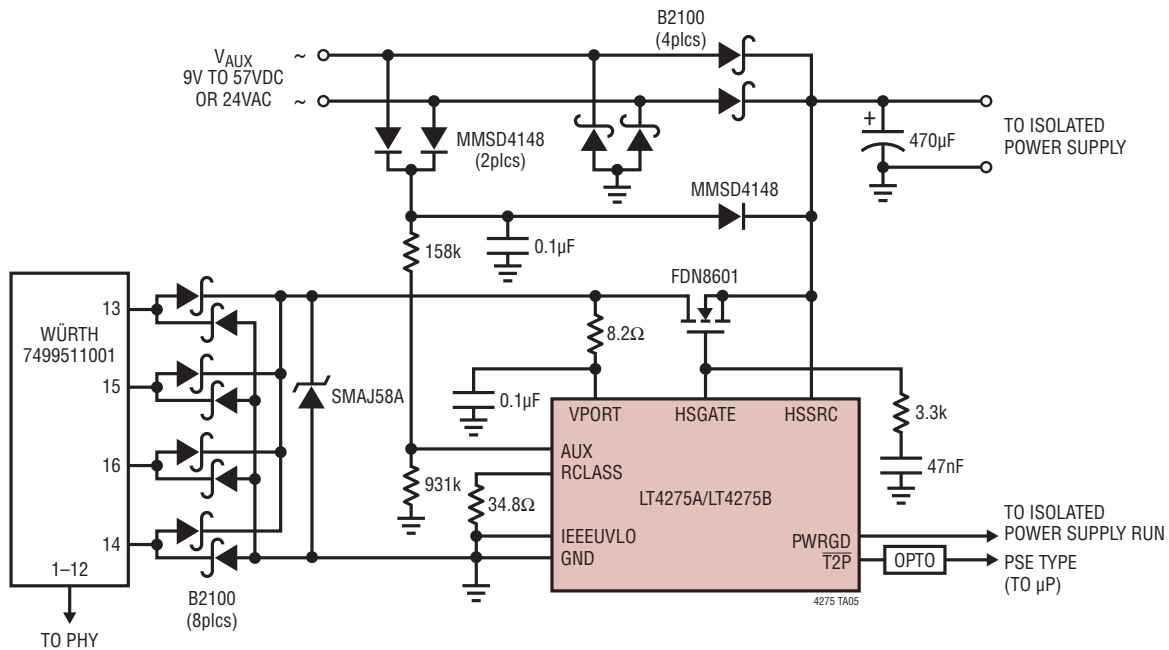



## RELATED PARTS

| PART NUMBER     | DESCRIPTION   | COMMENTS  |
|-----------------|---|---|
| LTC4257-1       | IEEE 802.3af PD Interface Controller                                  | Internal 100V, 400mA Switch, Dual Current Limit, Programmable Class   |
| LTC4263         | Single IEEE 802.3af PSE Controller                                    | Internal FET Switch   |
| LTC4265         | IEEE 802.3at PD Interface Controller                                  | Internal 100V, 1A Switch, 2-Event Classification Recognition  |
| LTC4266         | Quad IEEE 802.3at PoE PSE Controller                                  | With Programmable $I_{CUT}/I_{LIM}$ , 2-Event Classification  |
| LTC4266A        | Quad LTPoE++ PSE Controller   | Provides Up to 90W. Backwards Compatible with IEEE 802.3af and IEEE 802.3at PDs. With Programmable $I_{CUT}/I_{LIM}$ , 2-Event Classification |
| LTC4266C        | Quad IEEE 802.3af PSE Controller                                      | With Programmable $I_{CUT}/I_{LIM}$ , 1-Event Classification  |
| LTC4267-3       | IEEE 802.3af PD Interface with Integrated Switching Regulator         | Internal 100V, 400mA Switch, Programmable Class, 300kHz Constant Frequency PWM  |
| LTC4269-1       | IEEE 802.3af PD Interface with Integrated Flyback Switching Regulator | 2-Event Classification, Programmable Class, Synchronous No-Opto Flyback Controller, 50kHz to 250kHz, Aux Support                              |
| LTC4269-2       | IEEE 802.3af PD Interface with Integrated Forward Switching Regulator | 2-Event Classification, Programmable Class, Synchronous Forward Controller, 100kHz to 500kHz, Aux Support                                     |
| LTC4270/LTC4271 | 12-Port PoE/PoE+/LTPoE++ PSE Controller                               | Transformer Isolation, Supports IEEE 802.3af, IEEE 802.3at and LTPoE++ PDs  |
| LTC4274         | Single IEEE 802.3at PoE PSE Controller                                | With Programmable $I_{CUT}/I_{LIM}$ , 2-Event Classification  |
| LTC4274A        | Single LTPoE++ PSE Controller   | Provides Up to 90W. Backwards Compatible with IEEE 802.3 PDs. With Programmable $I_{CUT}/I_{LIM}$ , 2-Event Classification                    |
| LTC4274C        | Single IEEE 802.3af PSE Controller                                    | With Programmable $I_{CUT}/I_{LIM}$ , 1-Event Classification  |
| LTC4278         | IEEE 802.3af PD Interface with Integrated Flyback Switching Regulator | 2-Event Classification, Programmable Class, Synchronous No-Opto Flyback Controller, 50kHz to 250kHz, 12V Aux Support                          |
| LTC4290/LTC4271 | 8-Port PoE/PoE+/LTPoE++ PSE Controller                                | Transformer Isolation, Supports IEEE 802.3af, IEEE 802.3at and LTPoE++ PDs  |

## Looking for pricing, stock, or lifecycle information?

Click below to explore more details on WIN SOURCE:

-  [View LT4275BHDD#PBF on WIN SOURCE](#)
-  [Analog Devices Inc. Information](#)

## Optimize Your Supply Chain with WIN SOURCE Solutions

-  Global Sourcing Solution
-  Obsolete Management
-  Cost Control Management
-  Shortage Management
-  Alternative Solution
-  Excess Inventory Management