

XMC4300

Microcontroller Series
for Industrial Applications

XMC4000 Family

ARM[®] Cortex[®]-M4
32-bit processor core

Data Sheet

V1.2 2023-04

Microcontrollers

Edition 2023-04

**Published by
Infineon Technologies AG
81726 Munich, Germany**

**© 2023 Infineon Technologies AG
All Rights Reserved.**

Legal Disclaimer

The information given in this document shall in no event be regarded as a guarantee of conditions or characteristics. With respect to any examples or hints given herein, any typical values stated herein and/or any information regarding the application of the device, Infineon Technologies hereby disclaims any and all warranties and liabilities of any kind, including without limitation, warranties of non-infringement of intellectual property rights of any third party.

Information

For further information on technology, delivery terms and conditions and prices, please contact the nearest Infineon Technologies Office (www.infineon.com).

Warnings

Due to technical requirements, components may contain dangerous substances. For information on the types in question, please contact the nearest Infineon Technologies Office.

Infineon Technologies components may be used in life-support devices or systems only with the express written approval of Infineon Technologies, if a failure of such components can reasonably be expected to cause the failure of that life-support device or system or to affect the safety or effectiveness of that device or system. Life support devices or systems are intended to be implanted in the human body or to support and/or maintain and sustain and/or protect human life. If they fail, it is reasonable to assume that the health of the user or other persons may be endangered.

XMC4300

Microcontroller Series
for Industrial Applications

XMC4000 Family

ARM[®] Cortex[®]-M4
32-bit processor core

Data Sheet

V1.2 2023-04

XMC4300 Data Sheet

Revision History: V1.2 2023-04

V1.1 2018-09

V1.0 2016-02

Page	Subjects
V1.2 2023-04	
10	Updated number of breakpoints from 8 to 6.
99	Added PG-LQFP-100-29 details in Table 60.
102	Added package diagram: PG-LQFP-100-29.

Trademarks

C166™, TriCore™, XMC™ and DAVE™ are trademarks of Infineon Technologies AG.
ARM®, ARM Powered®, Cortex®, Thumb® and AMBA® are registered trademarks of ARM, Limited.

CoreSight™, ETM™, Embedded Trace Macrocell™ and Embedded Trace Buffer™ are trademarks of ARM, Limited.

Synopsys™ is a trademark of Synopsys, Inc.

We Listen to Your Comments

Is there any information in this document that you feel is wrong, unclear or missing?
Your feedback will help us to continuously improve the quality of this document.

Please send your proposal (including a reference to this document) to:

mcdocu.comments@infineon.com



Table of Contents

1	Summary of Features	8
1.1	Ordering Information	10
1.2	Device Types	10
1.3	Device Type Features	11
1.4	Definition of Feature Variants	11
1.5	Identification Registers	12
2	General Device Information	13
2.1	Logic Symbols	13
2.2	Pin Configuration and Definition	14
2.2.1	Package Pin Summary	15
2.2.2	Port I/O Functions	20
2.2.2.1	Port I/O Function Table	21
2.3	Power Connection Scheme	25
3	Electrical Parameters	27
3.1	General Parameters	27
3.1.1	Parameter Interpretation	27
3.1.2	Absolute Maximum Ratings	28
3.1.3	Pin Reliability in Overload	29
3.1.4	Pad Driver and Pad Classes Summary	32
3.1.5	Operating Conditions	33
3.2	DC Parameters	34
3.2.1	Input/Output Pins	34
3.2.2	Analog to Digital Converters (VADC)	41
3.2.3	Digital to Analog Converters (DAC)	46
3.2.4	Out-of-Range Comparator (ORC)	49
3.2.5	Die Temperature Sensor	51
3.2.6	USB OTG Interface DC Characteristics	52
3.2.7	Oscillator Pins	54
3.2.8	Power Supply Current	58
3.2.9	Flash Memory Parameters	62
3.3	AC Parameters	64
3.3.1	Testing Waveforms	64
3.3.2	Power-Up and Supply Monitoring	65
3.3.3	Power Sequencing	67
3.3.4	Phase Locked Loop (PLL) Characteristics	68
3.3.5	Internal Clock Source Characteristics	69
3.3.6	JTAG Interface Timing	71
3.3.7	Serial Wire Debug Port (SW-DP) Timing	73
3.3.8	Peripheral Timing	74
3.3.8.1	Synchronous Serial Interface (USIC SSC) Timing	74

Table of Contents

3.3.8.2	Inter-IC (IIC) Interface Timing	77
3.3.8.3	Inter-IC Sound (IIS) Interface Timing	79
3.3.8.4	SDMMC Interface Timing	81
3.3.9	USB Interface Characteristics	89
3.3.10	Ethernet Interface (ETH) Characteristics	90
3.3.10.1	ETH Measurement Reference Points	90
3.3.10.2	ETH Management Signal Parameters (ETH_MDC, ETH_MDIO) ...	91
3.3.10.3	ETH RMII Parameters	92
3.3.11	EtherCAT (ECAT) Characteristics	94
3.3.11.1	ECAT Measurement Reference Points	94
3.3.11.2	ETH Management Signal Parameters (MCLK, MDIO)	94
3.3.11.3	MII Timing TX Characteristics	95
3.3.11.4	MII Timing RX Characteristics	97
3.3.11.5	Sync/Latch Timings	98
4	Package and Reliability	99
4.1	Package Parameters	99
4.1.1	Thermal Considerations	100
4.2	Package Outlines	101
5	Quality Declarations	103

About this Document

This Data Sheet is addressed to embedded hardware and software developers. It provides the reader with detailed descriptions about the ordering designations, available features, electrical and physical characteristics of the XMC4[12]00 series devices.

The document describes the characteristics of a superset of the XMC4[12]00 series devices. For simplicity, the various device types are referred to by the collective term XMC4[12]00 throughout this manual.

XMC4000 Family User Documentation

The set of user documentation includes:

- **Reference Manual**
 - describes the functionality of the superset of devices.
- **Data Sheets**
 - list the complete ordering designations, available features and electrical characteristics of derivative devices.
- **Errata Sheets**
 - list deviations from the specifications given in the related Reference Manual or Data Sheets. Errata Sheets are provided for the superset of devices.

Attention: Please consult all parts of the documentation set to attain consolidated knowledge about your device.

Application related guidance is provided by **Users Guides** and **Application Notes**.

Please refer to <http://www.infineon.com/xmc4000> to get access to the latest versions of those documents.

1 Summary of Features

The XMC4300 devices are members of the XMC4000 Family of microcontrollers based on the ARM Cortex-M4 processor core. The XMC4000 is a family of high performance and energy efficient microcontrollers optimized for Industrial Connectivity, Industrial Control, Power Conversion, Sense & Control.

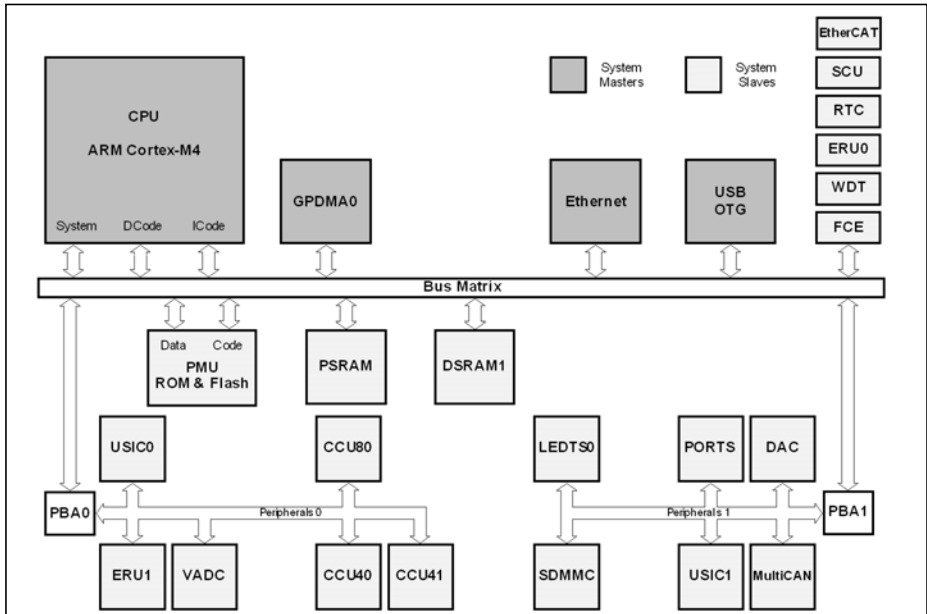

Figure 1 System Block Diagram

CPU Subsystem

- CPU Core
 - High Performance 32-bit ARM Cortex-M4 CPU
 - 16-bit and 32-bit Thumb2 instruction set
 - DSP/MAC instructions
 - System timer (SysTick) for Operating System support
- Floating Point Unit
- Memory Protection Unit
- Nested Vectored Interrupt Controller
- General Purpose DMA with up-to 8 channels
- Event Request Unit (ERU) for programmable processing of external and internal service requests
- Flexible CRC Engine (FCE) for multiple bit error detection

On-Chip Memories

- 16 KB on-chip boot ROM
- 64 KB on-chip high-speed program memory
- 64 KB on-chip high speed data memory
- 256 KB on-chip Flash Memory with 8 KB instruction cache

Communication Peripherals

- Ethernet MAC module capable of 10/100 Mbit/s transfer rates
- EtherCATslave interface (ECAT) capable of 100 Mbit/s transfer rates with 2 MII ports, 8 Fieldbus Memory Management Units (FMMU), 8 Sync Manager, 64 bit distributed clocks
- Universal Serial Bus, USB 2.0 host, Full-Speed OTG, with integrated PHY
- Controller Area Network interface (MultiCAN), Full-CAN/Basic-CAN with 2 nodes, 64 message objects (MO), data rate up to 1 MBaud
- Four Universal Serial Interface Channels (USIC), providing 4 serial channels, usable as UART, double-SPI, quad-SPI, IIC, IIS and LIN interfaces
- LED and Touch-Sense Controller (LEDTS) for Human-Machine interface
- SD and Multi-Media Card interface (SDMMC) for data storage memory cards

Analog Frontend Peripherals

- Two Analog-Digital Converters (VADC) of 12-bit resolution, 8 channels each, with input out-of-range comparators
- Digital-Analog Converter (DAC) with two channels of 12-bit resolution

Industrial Control Peripherals

- One Capture/Compare Units 8 (CCU8) for motor control and power conversion
- Two Capture/Compare Units 4 (CCU4) for use as general purpose timers
- Window Watchdog Timer (WDT) for safety sensitive applications
- Die Temperature Sensor (DTS)
- Real Time Clock module with alarm support
- System Control Unit (SCU) for system configuration and control

Input/Output Lines

- Programmable port driver control module (PORTS)
- Individual bit addressability
- Tri-stated in input mode
- Push/pull or open drain output mode
- Boundary scan test support over JTAG interface

On-Chip Debug Support

- Full support for debug features: 6 breakpoints, CoreSight, trace
- Various interfaces: ARM-JTAG, SWD, single wire trace

1.1 Ordering Information

The ordering code for an Infineon microcontroller provides an exact reference to a specific product. The code "XMC4<DDD>-<Z><PPP><T><FFFF>" identifies:

- <DDD> the derivatives function set
- <Z> the package variant
 - E: LFBGA
 - F: LQFP
 - Q: VQFN
- <PPP> package pin count
- <T> the temperature range:
 - F: -40°C to 85°C
 - K: -40°C to 125°C
- <FFFF> the Flash memory size.

For ordering codes for the XMC4300 please contact your sales representative or local distributor.

This document describes several derivatives of the XMC4300 series, some descriptions may not apply to a specific product. Please see [Table 1](#).

For simplicity the term **XMC4300** is used for all derivatives throughout this document.

1.2 Device Types

These device types are available and can be ordered through Infineon's direct and/or distribution channels.

Table 1 **Synopsis of XMC4300 Device Types**

Derivative ¹⁾	Package	Flash Kbytes	SRAM Kbytes
XMC4300-F100x256	PG-LQFP-100	256	128

1) x is a placeholder for the supported temperature range.

1.3 Device Type Features

The following table lists the available features per device type.

Table 2 Features of XMC4300 Device Types

Derivative ¹⁾	LED TS Intf.	SD MMC Intf.	ETH Intf.	ECAT Slave Intf.	USB Intf.	USIC Chan.	MultiCAN Nodes, MO
XMC4300-F100x256	1	1	RMII	2 x MII	1	2 x 2	N0, N1 MO[0..63]

1) x is a placeholder for the supported temperature range.

Table 3 Features of XMC4300 Device Types

Derivative ¹⁾	ADC Chan.	DAC Chan.	CCU4 Slice	CCU8 Slice
XMC4300-F100x256	16	2	2 x 4	1 x 4

1) x is a placeholder for the supported temperature range.

1.4 Definition of Feature Variants

The XMC4300 types are offered with several memory sizes and number of available VADC channels. [Table 4](#) describes the location of the available Flash memory, [Table 5](#) describes the location of the available SRAMs, [Table 6](#) the available VADC channels.

Table 4 Flash Memory Ranges

Total Flash Size	Cached Range	Uncached Range
256 Kbytes	0800 0000 _H – 0803 FFFF _H	0C00 0000 _H – 0C03 FFFF _H

Table 5 SRAM Memory Ranges

Total SRAM Size	Program SRAM	System Data SRAM
128 Kbytes	1FFF 0000 _H – 1FFF FFFF _H	2000 0000 _H – 2000 FFFF _H

Table 6 ADC Channels¹⁾

Package	VADC G0	VADC G1
PG-LQFP-100	CH0..CH7	CH0..CH7

1) Some pins in a package may be connected to more than one channel. For the detailed mapping see the Port I/O Function table.

1.5 Identification Registers

The identification registers allow software to identify the marking.

Table 7 XMC4300 Identification Registers

Register Name	Value	Marking
SCU_IDCHIP	0004 3001 _H	AA
JTAG IDCODE	101D F083 _H	AA

2 General Device Information

This section summarizes the logic symbols and package pin configurations with a detailed list of the functional I/O mapping.

2.1 Logic Symbols

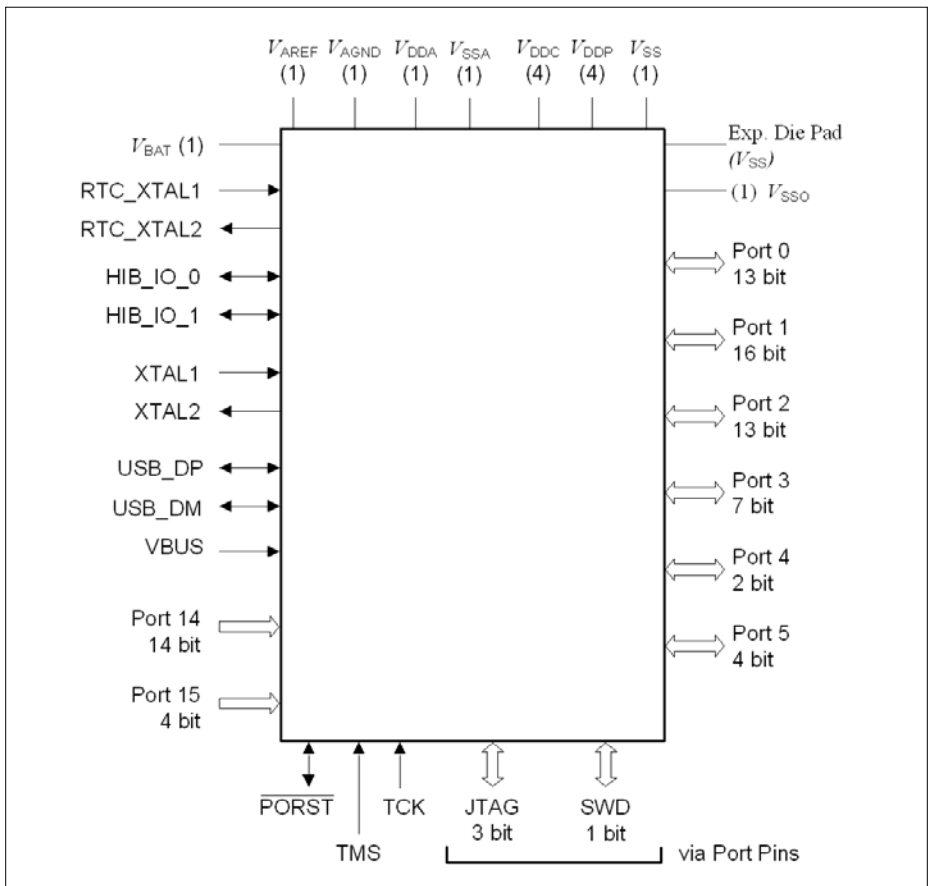

Figure 2 XMC4300 Logic Symbol PG-LQFP-100

2.2 Pin Configuration and Definition

The following figures summarize all pins, showing their locations on the four sides of the different packages.

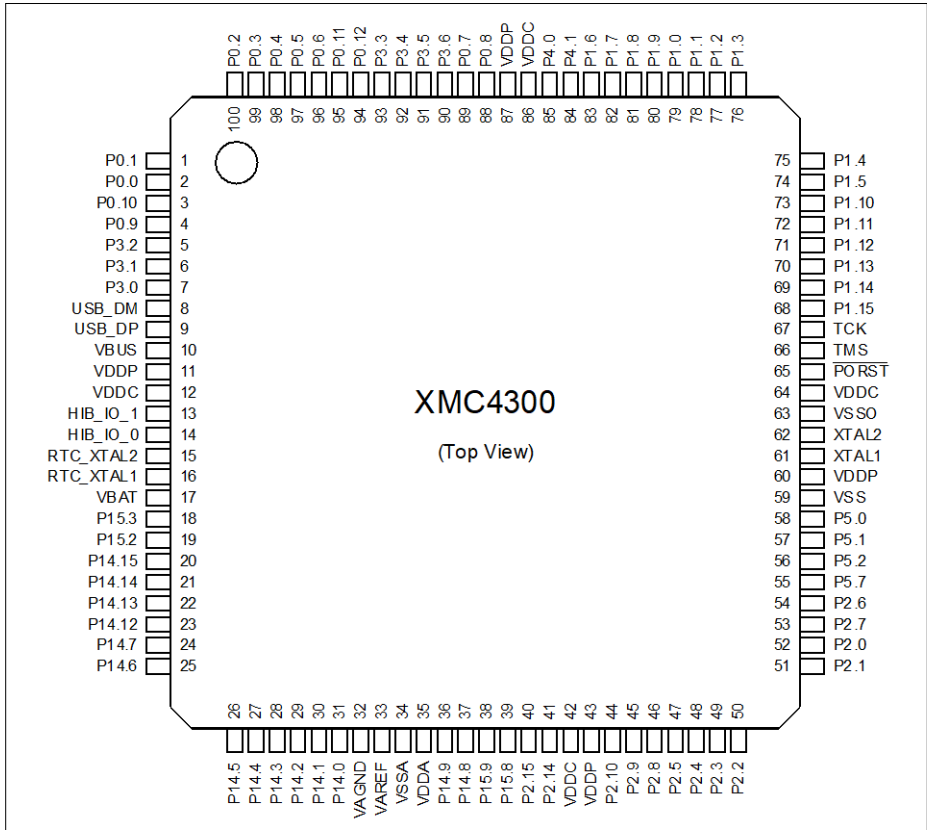

Figure 3 XMC4300 PG-LQFP-100 Pin Configuration (top view)

2.2.1 Package Pin Summary

The following general scheme is used to describe each pin:

Table 8 Package Pin Mapping Description

Function	Package A	Package B	...	Pad Type	Notes
Name	N	Ax	...	A2	

The table is sorted by the “Function” column, starting with the regular Port pins (Px.y), followed by the dedicated pins (i.e. PORST) and supply pins.

The following columns, titled with the supported package variants, lists the package pin number to which the respective function is mapped in that package.

The “Pad Type” indicates the employed pad type (A1, A1+, A2, special=special pad, In=input pad, AN/DIG_IN=analog and digital input, Power=power supply). Details about the pad properties are defined in the Electrical Parameters.

In the “Notes”, special information to the respective pin/function is given, i.e. deviations from the default configuration after reset. Per default the regular Port pins are configured as direct input with no internal pull device active.

Table 9 Package Pin Mapping

Function	LQFP-100	Pad Type	Notes
P0.0	2	A1+	
P0.1	1	A1+	
P0.2	100	A2	
P0.3	99	A2	
P0.4	98	A2	
P0.5	97	A2	
P0.6	96	A2	
P0.7	89	A2	After a system reset, via HWSEL this pin selects the DB.TDI function.
P0.8	88	A2	After a system reset, via HWSEL this pin selects the DB.TRST [̄] function, with a weak pull-down active.
P0.9	4	A2	
P0.10	3	A1+	
P0.11	95	A1+	
P0.12	94	A1+	

General Device Information

Table 9 Package Pin Mapping (cont'd)

Function	LQFP-100	Pad Type	Notes
P1.0	79	A1+	
P1.1	78	A1+	
P1.2	77	A2	
P1.3	76	A2	
P1.4	75	A1+	
P1.5	74	A1+	
P1.6	83	A2	
P1.7	82	A2	
P1.8	81	A2	
P1.9	80	A2	
P1.10	73	A1+	
P1.11	72	A1+	
P1.12	71	A2	
P1.13	70	A2	
P1.14	69	A2	
P1.15	68	A2	
P2.0	52	A2	
P2.1	51	A2	After a system reset, via HWSEL this pin selects the DB.TDO function.
P2.2	50	A2	
P2.3	49	A2	
P2.4	48	A2	
P2.5	47	A2	
P2.6	54	A1+	
P2.7	53	A1+	
P2.8	46	A2	
P2.9	45	A2	
P2.10	44	A2	
P2.14	41	A2	
P2.15	40	A2	
P3.0	7	A2	
P3.1	6	A2	

Table 9 Package Pin Mapping (cont'd)

Function	LQFP-100	Pad Type	Notes
P3.2	5	A2	
P3.3	93	A1+	
P3.4	92	A1+	
P3.5	91	A2	
P3.6	90	A2	
P4.0	85	A2	
P4.1	84	A2	
P5.0	58	A1+	
P5.1	57	A1+	
P5.2	56	A1+	
P5.7	55	A1+	
P14.0	31	AN/DIG_IN	
P14.1	30	AN/DIG_IN	
P14.2	29	AN/DIG_IN	
P14.3	28	AN/DIG_IN	
P14.4	27	AN/DIG_IN	
P14.5	26	AN/DIG_IN	
P14.6	25	AN/DIG_IN	
P14.7	24	AN/DIG_IN	
P14.8	37	AN/DAC/DIG_IN	
P14.9	36	AN/DAC/DIG_IN	
P14.12	23	AN/DIG_IN	
P14.13	22	AN/DIG_IN	
P14.14	21	AN/DIG_IN	
P14.15	20	AN/DIG_IN	
P15.2	19	AN/DIG_IN	
P15.3	18	AN/DIG_IN	
P15.8	39	AN/DIG_IN	
P15.9	38	AN/DIG_IN	

General Device Information
Table 9 Package Pin Mapping (cont'd)

Function	LQFP-100	Pad Type	Notes
HIB_IO_0	14	A1 special	At the first power-up and with every reset of the hibernate domain this pin is configured as open-drain output and drives "0". As output the medium driver mode is active.
HIB_IO_1	13	A1 special	At the first power-up and with every reset of the hibernate domain this pin is configured as input with no pull device active. As output the medium driver mode is active.
USB_DP	9	special	
USB_DM	8	special	
TCK	67	A1	Weak pull-down active.
TMS	66	A1+	Weak pull-up active. As output the strong-soft driver mode is active.
$\overline{\text{PORST}}$	65	special	Weak pull-up permanently active, strong pull-down controlled by EVR.
XTAL1	61	clock_IN	
XTAL2	62	clock_O	
RTC_XTAL1	16	clock_IN	
RTC_XTAL2	15	clock_O	
VBAT	17	Power	When VDDP is supplied VBAT has to be supplied as well.
VBUS	10	special	
VAREF	33	AN_Ref	
VAGND	32	AN_Ref	
VDDA	35	AN_Power	
VSSA	34	AN_Power	
VDDC	12	Power	
VDDC	42	Power	
VDDC	64	Power	
VDDC	86	Power	
VDDP	11	Power	

General Device Information

Table 9 Package Pin Mapping (cont'd)

Function	LQFP-100	Pad Type	Notes
VDDP	43	Power	
VDDP	60	Power	
VDDP	87	Power	
VSS	59	Power	
VSSO	63	Power	
VSS	Exp. Pad	Power	<p>Exposed Die Pad</p> <p>The exposed die pad is connected internally to VSS. For proper operation, it is mandatory to connect the exposed pad directly to the common ground on the board. For thermal aspects, please refer to the Data Sheet. Board layout examples are given in an application note.</p>

2.2.2 Port I/O Functions

The following general scheme is used to describe each Port pin:

Table 10 Port I/O Function Description

Function	Outputs			Inputs		
	ALT1	ALTn	HWO0	HWI0	Input	Input
P0.0		MODA.OUT	MODB.OUT	MODB.INA	MODC.INA	
Pn.y	MODA.OUT				MODA.INA	MODC.INB

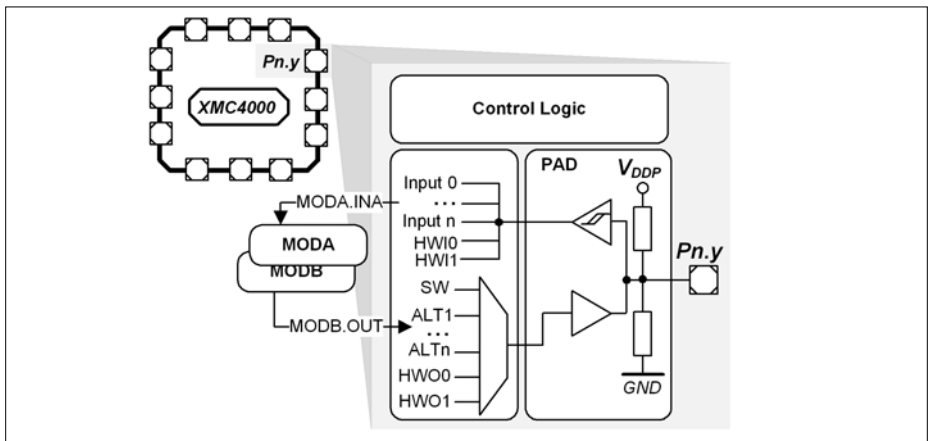

Figure 4 Simplified Port Structure

Pn.y is the port pin name, defining the control and data bits/registers associated with it. As GPIO, the port is under software control. Its input value is read via Pn_IN.y, Pn_OUT defines the output value.

Up to four alternate output functions (ALT1/2/3/4) can be mapped to a single port pin, selected by Pn_IOCR.PC. The output value is directly driven by the respective module, with the pin characteristics controlled by the port registers (within the limits of the connected pad).

The port pin input can be connected to multiple peripherals. Most peripherals have an input multiplexer to select between different possible input sources.

The input path is also active while the pin is configured as output. This allows to feedback an output to on-chip resources without wasting an additional external pin.

By Pn_HWSEL it is possible to select between different hardware “masters” (HWO0/HWI0). The selected peripheral can take control of the pin(s). Hardware control overrules settings in the respective port pin registers.

2.2.2.1 Port I/O Function Table

Table 11 Port I/O Functions

Function	Output					Input									
	ALT1	ALT2	ALT3	ALT4	HWO0	HWI0	Input	Input	Input	Input	Input	Input	Input	Input	Input
P0.0	ECAT0. PHY_RST	GAN. NO_TXD	CCU80. OUT21	LEDS0. COL2	U1C1. COL2		U1C1. DXXD	ETH0. CLK_RMIB	ERU0. 080						ETH0. GLRXRB
P0.1	USB. DRIVE/VEUS	U1C1. DOU70	CCU80. OUT11	LEDS0. COL3	U1C0. COL3		ETH0. GRL_DVB	ERU0. 040							ECAT0. P1_RX_CLKA
P0.2	ECAT0. P1_TXD2	U1C1. SEL01	CCU80. OUT01		U1C0. HWIN3	U1C0. HWIN3	ETH0. RXDVB	ERU0. 383							
P0.3	ECAT0. P1_RXD3	U1C0. HWIN2	CCU80. OUT20		U1C0. HWIN2	U1C0. HWIN2	ETH0. RADVB	ERU1. 380							
P0.4	ETH0. TX_EN	CCU80. OUT10	U1C0. DOU11		U1C0. HWIN1	U1C0. HWIN1	U1C0. DX0A	ERU0. 283							ECAT0. P1_RXD0A
P0.5	ETH0. TXD0	U1C0. DOU10	CCU80. OUT00		U1C0. HWIN0	U1C0. HWIN0	U1C0. DX0B	ERU1. 340							ECAT0. P1_RXD2A
P0.6	ETH0. TAG1	U1C0. SEL00	CCU80. OUT30				U1C0. DX2A	ERU0. 382							ECAT0. P1_RXD1A
P0.7	WWDT. SERVICE_OUT	U0C0. SEL00	ECAT0. LED_ERR		DB. TDI		U0C0. DX2B	ERU0. 281							CCU80. IN2A
P0.8	SQU. EXTCLK	U0C0. SCLKOUT	ECAT0. LED_RUN		DB. FRST		U0C0. DX1B	ERU0. 2A1							CCU80. IN2A
P0.9		U1C1. SEL00	CCU80. OUT12		ETH0. MDIA		U1C1. DX2A	USB. ID	ERU0. 180						ECAT0. P1_RX_DVIA
P0.10	ETH0. MDC	U1C1. SCLKOUT	CCU80. OUT02	LEDS0. COL1			U1C1. DX1A	ERU0. 140							ECAT0. P1_TX_CLKA
P0.11	ECAT0. P1_LINK_ACT	U1C0. SCLKOUT	CCU80. OUT31	SDMMC. RST			ETH0. RXERB	ERU0. 342							ECAT0. P1_RXD0A
P0.12		U1C1. SEL00	CCU80. OUT3	ECAT0. MDC			U1C1. DX2B	ERU0. 282							
P1.0		U0C0. SEL00	CCU40. OUT3	ERU1. PROU73			U0C0. DX2A	ERU0. 380							ECAT0. P0_RX_CLKA
P1.1		U0C0. SCLKOUT	CCU40. OUT2	ERU1. PROU72	SDMMC. SDWC		U0C0. DX1A	ERU0. 340							ECAT0. P0_RX_CLKA
P1.2	ECAT0. P0_TXD3	CCU40. OUT1	CCU40. PROU71	U0C0. DOU73	U0C0. HWIN3			ERU1. 280							
P1.3	ECAT0. P0_TX_ENA	U0C0. MCLKOUT	CCU40. OUT0	U0C0. DOU72	U0C0. HWIN2			ERU1. 240							
P1.4	WWDT. SERVICE_OUT	GAN. NO_TXD	CCU80. OUT33	U0C0. DOU11	U0C0. HWIN1		U0C0. DX0B	ERU0. 280							ECAT0. P0_RXD0A
P1.5	GAN. N1_TXD	U0C0. DOU10	CCU80. OUT23	U0C0. DOU10	U0C0. HWIN0		U0C0. DX0A	ERU1. 040							ECAT0. P0_RXD1A
P1.6	ECAT0. P0_TXD0	U0C0. SCLKOUT		SDMMC. DATA1_OUT	SDMMC. DATA1_IN										

Table 11 Port I/O Functions (cont'd)

Function	Output						Input						
	ALT1	ALT2	ALT3	ALT4	HWO0	HWO0	HWI0	HWI0	HWI0	HWI0	HWI0	HWI0	HWI0
P1.7	ECAT0_P0_TXD3	U0C0_DOUT0		U1C1_SELO2	SDMMC_DATA2_OUT	SDMMC_DATA2_IN							
P1.8	ECAT0_P0_TXD2	U0C0_SELO1		U1C1_SCLKOUT	SDMMC_DATA1_OUT	SDMMC_DATA1_IN							
P1.9	U1C0_SCLKOUT			U1C1_DOUT0	SDMMC_DATA5_OUT	SDMMC_DATA5_IN							ECAT0_P0_RX_DVIA
P1.10	ETH0_MDC	U0C0_SCLKOUT		ECAT0_LED_ERR	SDMMC_SEO2	SDMMC_SEO2					CCU41_IN2C		ECAT0_P0_RXD2A
P1.11	ECAT0_LED_STATE_R UN	U0C0_SELO2		ECAT0_LED_RUN	ETH0_MDO	ETH0_MDI					CCU41_IN3C		ECAT0_P0_RXD3A
P1.12	ETH0_TX_EN	CAN_M1_TXD		ECAT0_PA_LINK_ACT	SDMMC_DATA5_OUT	SDMMC_DATA5_IN							
P1.13	ETH0_TXD0	U0C1_SELO3		ECAT0_PHY_CLK25	SDMMC_DATA7_OUT	SDMMC_DATA7_IN	CAN_M1_RXDC						
P1.14	ETH0_TXD1	U0C1_SELO2		ECAT0_SYNC0	U1C0_DX0E	U1C0_DX0E							
P1.15	SQU_EXCLK			U1C0_DOUT0						ERU1_1A0			ECAT0_P0_LINKB
P2.0	CAN_M0_TXD			LEDTS0_C0L1	ETH0_MDO	ETH0_MDI			ERU0_0B3		CCU40_IN1C		
P2.1				LEDTS0_C0L0	DB_TD0/ TRACESWO	ETH0_CLK_RMIIA			ERU1_0B0		CCU40_IN0C		ETH0_CLKRXVA
P2.2	VADC_EMU000			LEDTS0_LINE9	LEDTS0_TSN0A	LEDTS0_TSN0A	ETH0_CLK_RMIIA	U0C1_DX2A			CCU41_IN3A		
P2.3	VADC_EMU001	U0C1_SELO0		LEDTS0_LINE1	LEDTS0_EXTENDE0	LEDTS0_TSN1A	ETH0_CLK_RMIIA	U0C1_DX2A			CCU41_IN3A		
P2.4	VADC_EMU002	U0C1_SCLKOUT		LEDTS0_LINE2	LEDTS0_EXTENDE2	LEDTS0_TSN2A	ETH0_CLK_RMIIA	U0C1_DX1A			CCU41_IN1A		
P2.5	ETH0_TX_EN	U0C1_DOUT0		LEDTS0_LINE3	LEDTS0_EXTENDE3	LEDTS0_TSN3A	ETH0_CLK_RMIIA	U0C1_DX2B			CCU41_IN3A		ETH0_CRS_DVA
P2.6		ERU1_PDOU73		LEDTS0_C0L3				CAN_M1_RXDVA			CCU40_IN3C		ECAT0_P0_RX_ERRB
P2.7	ETH0_MDC	CAN_M1_TXD		LEDTS0_C0L2						ERU1_1B0	CCU40_IN0C		
P2.8	ETH0_TXD0	ERU1_PDOU71		LEDTS0_LINE4	LEDTS0_EXTENDE4	LEDTS0_TSN4A	DAC_TRIGGERS				CCU40_IN1B		CCU40_IN2B
P2.9	ETH0_TXD1	ERU1_PDOU72		LEDTS0_LINE5	LEDTS0_EXTENDE5	LEDTS0_TSN5A	DAC_TRIGGERS4				CCU41_IN1B		CCU41_IN2B
P2.10	VADC_EMU010	ERU1_PDOU70		ECAT0_PHY_RST									
P2.14	VADC_EMU011	DOUT0		U1C0_OUT21				U1C0_DX0D					
P2.15	VADC_EMU012	ECAT0_P1_TXD3		LEDTS0_OUT11	LEDTS0_EXTENDE6	LEDTS0_TSN6A	ETH0_C0LA						

Table 11 Port I/O Functions (cont'd)

Function	Output				Input								
	ALT1	ALT2	ALT3	ALT4	HWO0	HWI0	Input	Input	Input	Input	Input	Input	Input
P3.0		UIC1_SCLKOUT		ECATO_P1_TX_ENA			UIC1_DX1B		CCU80_INZC				
P3.1		UIC1_SELO0	ECATO_P1_TXD0				UIC1_DZ0B	ERU0_0A1	CCU80_INVC				
P3.2	USB_DRIVE/USB	GAN_NO_TXD	ECATO_P1_TXD1	LEDTS0_COLA	SDMMC_LED			ERU0_0A1	CCU80_INOC				
P3.3		UIC1_SELO1		ECATO_MCLK	SDMMC_BUS_POWER					CCU80_INSB			
P3.4		UIC1_SELO2			SDMMC_CMD_OUT					CCU80_INSB		ECATO_P1_LINxA	
P3.5		UIC1_SELO3		UIC1_DOUT0	SDMMC_CMD_IN			ERU0_3B1				ECATO_P1_RX_ERRA	
P3.6		UIC1_SELO4		UIC1_SCLKOUT	SDMMC_CLK_OUT			ERU0_3A1					
P4.0		ECATO_PHY_CLK2S		UIC0_SCLKOUT	SDMMC_DATA0_OUT		UIC1_DX1C	UIC1_DX0E					ECATO_P0_RX_ERRA
P4.1		UIC1_MCLKOUT		UIC1_SELO0	SDMMC_DATA1_OUT								ECATO_P0_LINxA
P5.0				ERU1_PRODUT0				UIC0_DX0D	ECATO_P0_RXD0B				
P5.1	UIC0_DOUT0			ERU1_PRODUT1				ETH0_RXD1D	ECATO_P0_RXD1B				
P5.2		ECATO_P0_LINxA_ACT		ERU1_PRODUT2				ETH0_GRS_DV0	ECATO_P0_RXD2B				ETH0_RXD20
P5.7	ECATO_SYNC0			LEDTS0_COLA					ECATO_P0_RXD3B				
P14.0							VADC_G0CH0						
P14.1							VADC_G0CH1						
P14.2							VADC_G0CH2						
P14.3							VADC_G0CH3		CAN_NO_RXD0B				
P14.4							VADC_G0CH4						ECATO_LATCHIA
P14.5							VADC_G0CH5						ECATO_LATCHIA
P14.6							VADC_G0CH6						ECATO_P1_RX_CLKB
P14.7							VADC_G0CH7						ECATO_P1_RXD0B
P14.8				DAC_OUT_0			VADC_G1CH0						
P14.9				DAC_OUT_1			VADC_G1CH1						

Table 11 Port I/O Functions (cont'd)

Function	Output					Input						
	ALT1	ALT2	ALT3	ALT4	HWO0	HWI0	Input	Input	Input	Input	Input	
P14.12								VADC, G1CH4				ECATO, P1_RXD1B
P14.13								VADC, G1CH5				ECATO, P1_RXD2B
P14.14								VADC, G1CH6				ECATO, P1_RXD3B
P14.15								VADC, G1CH7				ECATO, P1_RX_DVB
P15.2												ECATO, P1_RX_ERRB
P15.3												ECATO, P1_LINB
P15.8										ETH0, CLK_RMII		ETH0, CLK_RXC
P15.9										ETH0, CRS_DVC		ETH0, RXDVC
HIB_IO_0	HBOUT	WWDT, SERVICE_OUT					WAKEUPA					
HIB_IO_1	HBOUT	WWDT, SERVICE_OUT					WAKEUPB					
USB_DP												
USB_DM												
TOK							DBTCK/ SWCLK					
TMS												
FORST												
XTAL1							USC0, DX0F	USC1, DX0F	USC0, DX0F	USC1, DX0F		
XTAL2												
RTC_XTAL1										ERIU0, IB1		
RTC_XTAL2												

2.3 Power Connection Scheme

Figure 5 shows a reference power connection scheme for the XMC4300.

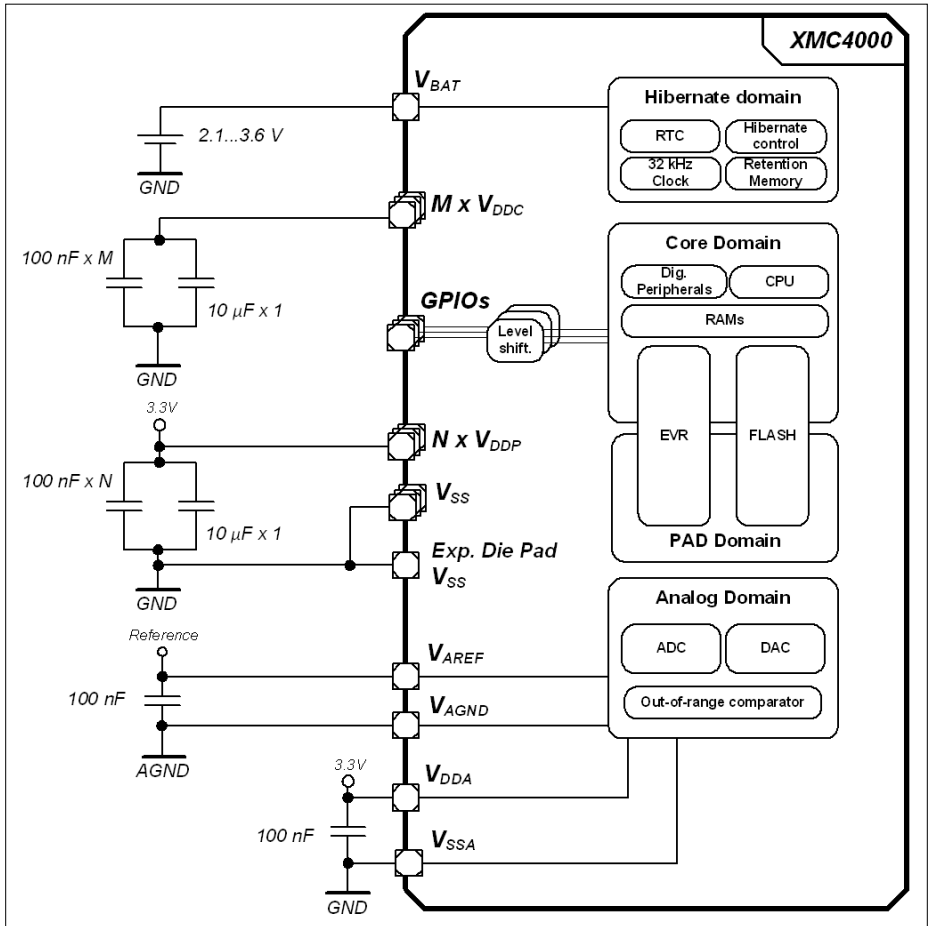

Figure 5 Power Connection Scheme

Every power supply pin needs to be connected. Different pins of the same supply need also to be externally connected. As example, all V_{DDP} pins must be connected externally to one V_{DDP} net. In this reference scheme one 100 nF capacitor is connected at each supply pin against V_{SS} . An additional 10 μ F capacitor is connected to the V_{DDP} nets and an additional 10 μ F capacitor to the V_{DDC} nets.

The XMC4300 has a common ground concept, all V_{SS} , V_{SSA} and V_{SSO} pins share the same ground potential. In packages with an exposed die pad it must be connected to the common ground as well.

V_{AGND} is the low potential to the analog reference V_{AREF} . Depending on the application it can share the common ground or have a different potential. In devices with shared V_{DDA}/V_{AREF} and V_{SSA}/V_{AGND} pins the reference is tied to the supply. Some analog channels can optionally serve as “Alternate Reference”; further details on this operating mode are described in the Reference Manual.

When V_{DDP} is supplied, V_{BAT} must be supplied as well. If no other supply source (e.g. battery) is connected to V_{BAT} , the V_{BAT} pin can also be connected directly to V_{DDP} .

3 Electrical Parameters

Attention: All parameters in this chapter are preliminary target values and may change based on characterization results.

3.1 General Parameters

3.1.1 Parameter Interpretation

The parameters listed in this section partly represent the characteristics of the XMC4300 and partly its requirements on the system. To aid interpreting the parameters easily when evaluating them for a design, they are marked with a two-letter abbreviation in column "Symbol":

- **CC**
Such parameters indicate **C**ontroller **C**haracteristics, which are a distinctive feature of the XMC4300 and must be regarded for system design.
- **SR**
Such parameters indicate **S**ystem **R**equirements, which must be provided by the application system in which the XMC4300 is designed in.

3.1.2 Absolute Maximum Ratings

Stresses above the values listed under “Absolute Maximum Ratings” may cause permanent damage to the device. This is a stress rating only and functional operation of the device at these or any other conditions above those indicated in the operational sections of this specification is not implied. Exposure to absolute maximum rating conditions may affect device reliability.

Table 12 Absolute Maximum Rating Parameters

Parameter	Symbol		Values			Unit	Note / Test Condition
			Min.	Typ.	Max.		
Storage temperature	T_{ST}	SR	-65	–	150	°C	–
Junction temperature	T_J	SR	-40	–	150	°C	–
Voltage at 3.3 V power supply pins with respect to V_{SS}	V_{DDP}	SR	–	–	4.3	V	–
Voltage on any Class A and dedicated input pin with respect to V_{SS}	V_{IN}	SR	-1.0	–	$V_{DDP} + 1.0$ or max. 4.3	V	whichever is lower
Voltage on any analog input pin with respect to V_{AGND}	V_{AIN} V_{AREF}	SR	-1.0	–	$V_{DDP} + 1.0$ or max. 4.3	V	whichever is lower
Input current on any pin during overload condition	I_{IN}	SR	-10	–	+10	mA	
Absolute maximum sum of all input circuit currents for one port group during overload condition ¹⁾	ΣI_{IN}	SR	-25	–	+25	mA	
Absolute maximum sum of all input circuit currents during overload condition	ΣI_{IN}	SR	-100	–	+100	mA	

1) The port groups are defined in [Table 16](#).

Figure 6 explains the input voltage ranges of V_{IN} and V_{AIN} and its dependency to the supply level of V_{DDP} . The input voltage must not exceed 4.3 V, and it must not be more than 1.0 V above V_{DDP} . For the range up to $V_{DDP} + 1.0$ V also see the definition of the overload conditions in “[Pin Reliability in Overload](#)”.

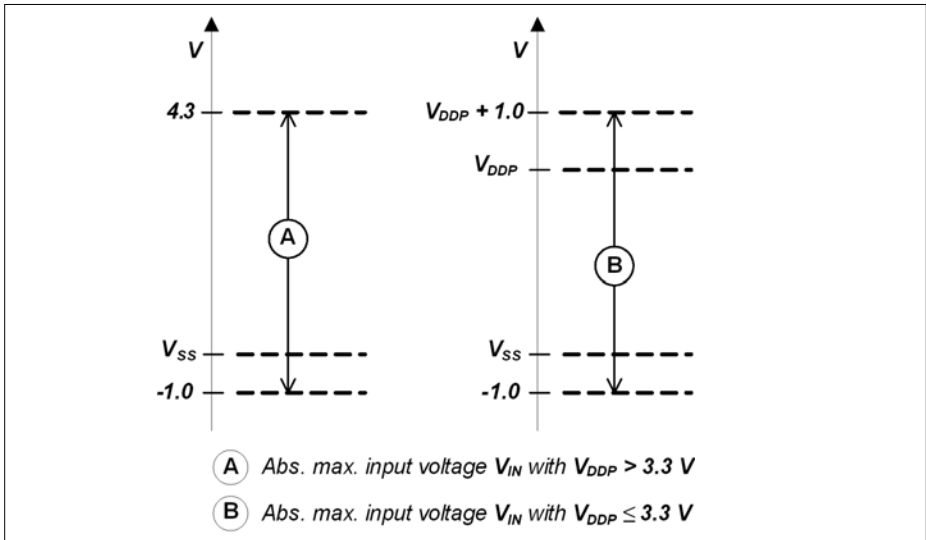

Figure 6 Absolute Maximum Input Voltage Ranges

3.1.3 Pin Reliability in Overload

When receiving signals from higher voltage devices, low-voltage devices experience overload currents and voltages that go beyond their own IO power supplies specification.

Table 13 defines overload conditions that will not cause any negative reliability impact if all the following conditions are met:

- full operation life-time is not exceeded
- “**Operating Conditions**” are met for
 - pad supply levels (V_{DDP} or V_{DDA})
 - temperature

If a pin current is outside of the “**Operating Conditions**” but within the overload conditions, then the parameters of this pin as stated in the Operating Conditions can no longer be guaranteed. Operation is still possible in most cases but with relaxed parameters.

Note: An overload condition on one or more pins does not require a reset.

Note: A series resistor at the pin to limit the current to the maximum permitted overload current is sufficient to handle failure situations like short to battery.

Table 13 **Overload Parameters**

Parameter	Symbol	Values			Unit	Note / Test Condition
		Min.	Typ.	Max.		
Input current on any port pin during overload condition	I_{OV} SR	-5	–	5	mA	
Absolute sum of all input circuit currents for one port group during overload condition ¹⁾	I_{OVG} SR	–	–	20	mA	$\Sigma I_{OVx} $, for all $I_{OVx} < 0$ mA
		–	–	20	mA	$\Sigma I_{OVx} $, for all $I_{OVx} > 0$ mA
Absolute sum of all input circuit currents during overload condition	I_{OVS} SR	–	–	80	mA	ΣI_{OVG}

1) The port groups are defined in [Table 16](#).

Figure 7 shows the path of the input currents during overload via the ESD protection structures. The diodes against V_{DDP} and ground are a simplified representation of these ESD protection structures.

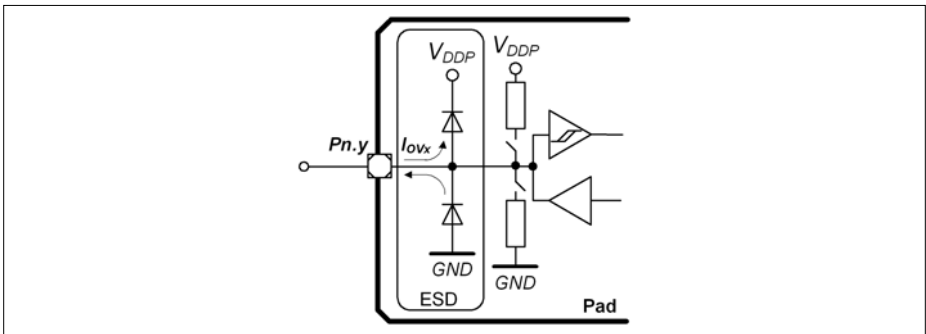

Figure 7 **Input Overload Current via ESD structures**

[Table 14](#) and [Table 15](#) list input voltages that can be reached under overload conditions. Note that the absolute maximum input voltages as defined in the “**Absolute Maximum Ratings**” must not be exceeded during overload.

Table 14 PN-Junction Characteristics for positive Overload

Pad Type	$I_{OV} = 5 \text{ mA}, T_J = -40 \text{ }^\circ\text{C}$	$I_{OV} = 5 \text{ mA}, T_J = 150 \text{ }^\circ\text{C}$
A1 / A1+	$V_{IN} = V_{DDP} + 1.0 \text{ V}$	$V_{IN} = V_{DDP} + 0.75 \text{ V}$
A2	$V_{IN} = V_{DDP} + 0.7 \text{ V}$	$V_{IN} = V_{DDP} + 0.6 \text{ V}$
AN/DIG_IN	$V_{IN} = V_{DDP} + 1.0 \text{ V}$	$V_{IN} = V_{DDP} + 0.75 \text{ V}$

Table 15 PN-Junction Characteristics for negative Overload

Pad Type	$I_{OV} = 5 \text{ mA}, T_J = -40 \text{ }^\circ\text{C}$	$I_{OV} = 5 \text{ mA}, T_J = 150 \text{ }^\circ\text{C}$
A1 / A1+	$V_{IN} = V_{SS} - 1.0 \text{ V}$	$V_{IN} = V_{SS} - 0.75 \text{ V}$
A2	$V_{IN} = V_{SS} - 0.7 \text{ V}$	$V_{IN} = V_{SS} - 0.6 \text{ V}$
AN/DIG_IN	$V_{IN} = V_{DDP} - 1.0 \text{ V}$	$V_{IN} = V_{DDP} - 0.75 \text{ V}$

Table 16 Port Groups for Overload and Short-Circuit Current Sum Parameters

Group	Pins
1	P0.[12:0], P3.[6:0]
2	P14.[15:0], P15.[9:2]
3	P2.[15:0], P5.[7:0]
4	P1.[15:0], P4.[1:0]

3.1.4 Pad Driver and Pad Classes Summary

This section gives an overview on the different pad driver classes and their basic characteristics.

Table 17 Pad Driver and Pad Classes Overview

Class	Power Supply	Type	Sub-Class	Speed Grade	Load	Termination
A	3.3 V	LVTTTL I/O	A1 (e.g. GPIO)	6 MHz	100 pF	No
			A1+ (e.g. serial I/Os)	25 MHz	50 pF	Series termination recommended
			A2 (e.g. ext. Bus)	80 MHz	15 pF	Series termination recommended

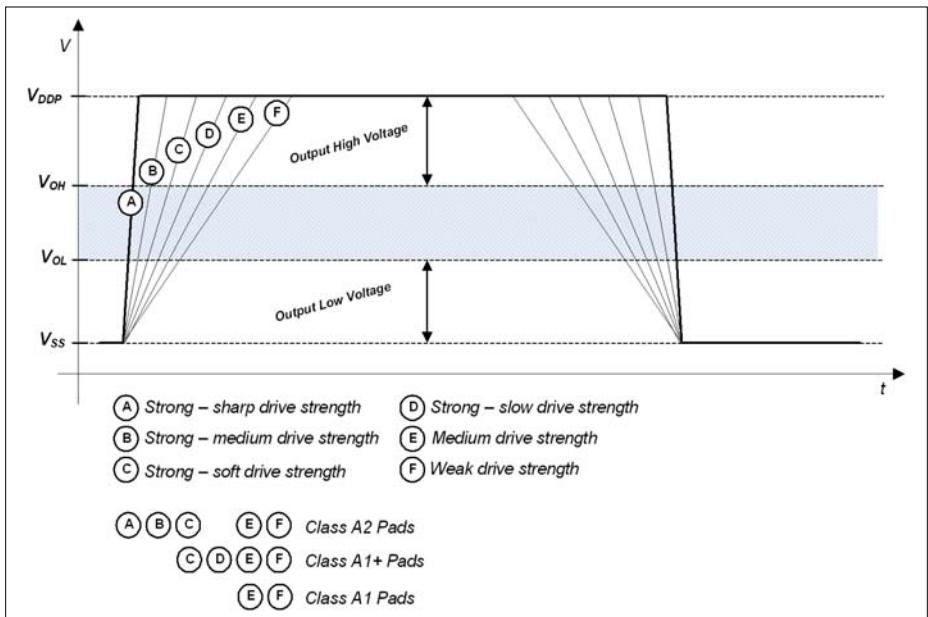

Figure 8 Output Slopes with different Pad Driver Modes

Figure 8 is a qualitative display of the resulting output slope performance with different output driver modes. The detailed input and output characteristics are listed in **“Input/Output Pins”**.

3.1.5 Operating Conditions

The following operating conditions must not be exceeded in order to ensure correct operation and reliability of the XMC4300. All parameters specified in the following sections refer to these operating conditions, unless noted otherwise.

Table 18 Operating Conditions Parameters

Parameter	Symbol	Values			Unit	Note / Test Condition
		Min.	Typ.	Max.		
Ambient Temperature	T_A SR	-40	–	85	°C	Temp. Range F
		-40	–	125	°C	Temp. Range K
Digital supply voltage	V_{DDP} SR	3.13 ¹⁾	3.3	3.63 ²⁾	V	
Core Supply Voltage	V_{DDC} CC	– ¹⁾	1.3	–	V	Generated internally
Digital ground voltage	V_{SS} SR	0	–	–	V	
ADC analog supply voltage	V_{DDA} SR	3.0	3.3	3.6 ²⁾	V	
Analog ground voltage for V_{DDA}	V_{SSA} SR	-0.1	0	0.1	V	
Battery Supply Voltage for Hibernate Domain	V_{BAT} SR	1.95 ³⁾	–	3.63	V	When V_{DDP} is supplied V_{BAT} has to be supplied as well.
System Frequency	f_{SYS} SR	–	–	144	MHz	
Short circuit current of digital outputs	I_{SC} SR	-5	–	5	mA	
Absolute sum of short circuit currents per pin group ⁴⁾	ΣI_{SC_PG} SR	–	–	20	mA	
Absolute sum of short circuit currents of the device	ΣI_{SC_D} SR	–	–	100	mA	

1) See also the Supply Monitoring thresholds, “[Power-Up and Supply Monitoring](#)”.

2) Voltage overshoot to 4.0 V is permissible at Power-Up and PORST low, provided the pulse duration is less than 100 μ s and the cumulated sum of the pulses does not exceed 1 h over lifetime.

3) To start the hibernate domain it is required that $V_{BAT} \geq 2.1$ V, for a reliable start of the oscillation of RTC_XTAL in crystal mode it is required that $V_{BAT} \geq 3.0$ V.

4) The port groups are defined in [Table 16](#).

3.2 DC Parameters

3.2.1 Input/Output Pins

The digital input stage of the shared analog/digital input pins is identical to the input stage of the standard digital input/output pins.

The Pull-up on the $\overline{\text{PORST}}$ pin is identical to the Pull-up on the standard digital input/output pins.

Note: These parameters are not subject to production test, but verified by design and/or characterization.

Table 19 Standard Pad Parameters

Parameter	Symbol	Values		Unit	Note / Test Condition
		Min.	Max.		
Pin capacitance (digital inputs/outputs)	C_{IO} CC	–	10	pF	
Pull-down current	$ I_{PDL} $ SR	150	–	μA	¹⁾ $V_{IN} \geq 0.6 \times V_{DDP}$
		–	10	μA	²⁾ $V_{IN} \leq 0.36 \times V_{DDP}$
Pull-Up current	$ I_{PUH} $ SR	–	10	μA	²⁾ $V_{IN} \geq 0.6 \times V_{DDP}$
		100	–	μA	¹⁾ $V_{IN} \leq 0.36 \times V_{DDP}$
Input Hysteresis for pads of all A classes ³⁾	HYS_A CC	$0.1 \times V_{DDP}$	–	V	
$\overline{\text{PORST}}$ spike filter always blocked pulse duration	t_{SF1} CC	–	10	ns	
$\overline{\text{PORST}}$ spike filter pass-through pulse duration	t_{SF2} CC	100	–	ns	
$\overline{\text{PORST}}$ pull-down current	$ I_{PPD} $ CC	13	–	mA	$V_{IN} = 1.0 \text{ V}$

1) Current required to override the pull device with the opposite logic level (“force current”).

With active pull device, at load currents between force and keep current the input state is undefined.

2) Load current at which the pull device still maintains the valid logic level (“keep current”).

With active pull device, at load currents between force and keep current the input state is undefined.

3) Hysteresis is implemented to avoid metastable states and switching due to internal ground bounce. It can not be guaranteed that it suppresses switching due to external system noise.

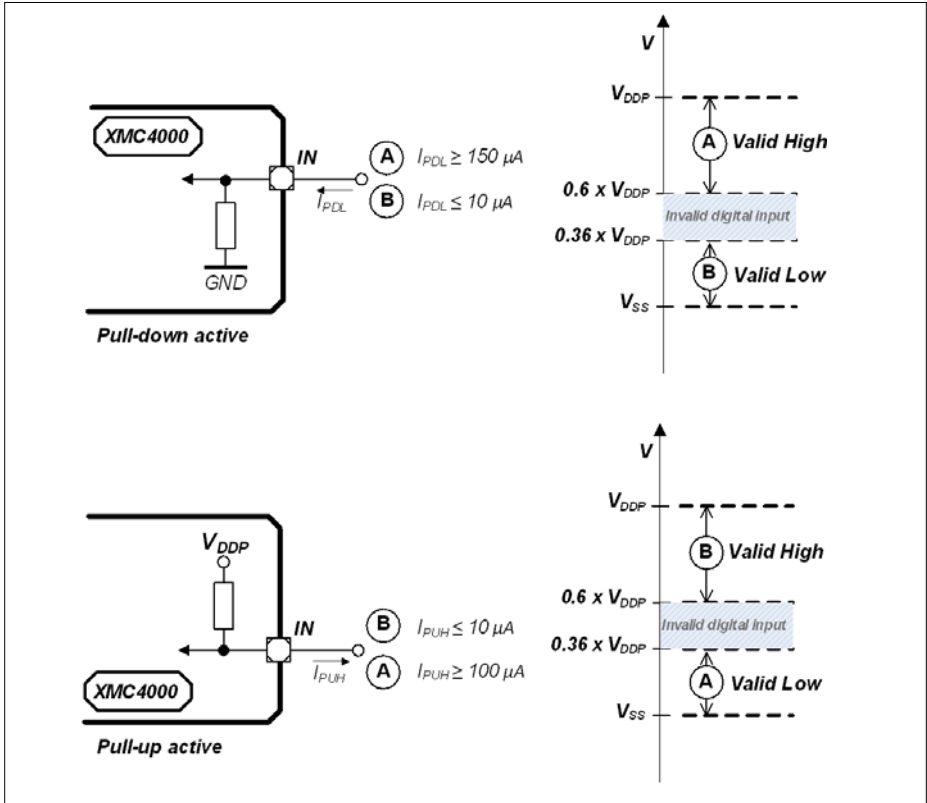

Figure 9 Pull Device Input Characteristics

Figure 9 visualizes the input characteristics with an active internal pull device:

- in the cases "A" the internal pull device is overridden by a strong external driver;
- in the cases "B" the internal pull device defines the input logical state against a weak external load.

Electrical Parameters
Table 20 Standard Pads Class_A1

Parameter	Symbol	Values		Unit	Note / Test Condition
		Min.	Max.		
Input leakage current	I_{OZA1} CC	-500	500	nA	$0\text{ V} \leq V_{IN} \leq V_{DDP}$
Input high voltage	V_{IHA1} SR	$0.6 \times V_{DDP}$	$V_{DDP} + 0.3$	V	max. 3.6 V
Input low voltage	V_{ILA1} SR	-0.3	$0.36 \times V_{DDP}$	V	
Output high voltage, POD ¹⁾ = weak	V_{OHA1} CC	$V_{DDP} - 0.4$	–	V	$I_{OH} \geq -400\ \mu\text{A}$
		2.4	–	V	$I_{OH} \geq -500\ \mu\text{A}$
Output high voltage, POD ¹⁾ = medium		$V_{DDP} - 0.4$	–	V	$I_{OH} \geq -1.4\ \text{mA}$
		2.4	–	V	$I_{OH} \geq -2\ \text{mA}$
Output low voltage	V_{OLA1} CC	–	0.4	V	$I_{OL} \leq 500\ \mu\text{A}$; POD ¹⁾ = weak
		–	0.4	V	$I_{OL} \leq 2\ \text{mA}$; POD ¹⁾ = medium
Fall time	t_{FA1} CC	–	150	ns	$C_L = 20\ \text{pF}$; POD ¹⁾ = weak
		–	50	ns	$C_L = 50\ \text{pF}$; POD ¹⁾ = medium
Rise time	t_{RA1} CC	–	150	ns	$C_L = 20\ \text{pF}$; POD ¹⁾ = weak
		–	50	ns	$C_L = 50\ \text{pF}$; POD ¹⁾ = medium

1) POD = Pin Out Driver

Table 21 Standard Pads Class_A1+

Parameter	Symbol	Values		Unit	Note / Test Condition
		Min.	Max.		
Input leakage current	I_{OZA1+} CC	-1	1	μA	$0\text{ V} \leq V_{IN} \leq V_{DDP}$
Input high voltage	V_{IHA1+} SR	$0.6 \times V_{DDP}$	$V_{DDP} + 0.3$	V	max. 3.6 V
Input low voltage	V_{ILA1+} SR	-0.3	$0.36 \times V_{DDP}$	V	

Electrical Parameters
Table 21 Standard Pads Class_A1+

Parameter	Symbol	Values		Unit	Note / Test Condition	
		Min.	Max.			
Output high voltage, POD ¹⁾ = weak	V _{OHA1+} CC	V _{DDP} - 0.4	–	V	I _{OH} ≥ -400 μA	
		2.4	–	V	I _{OH} ≥ -500 μA	
Output high voltage, POD ¹⁾ = medium		V _{DDP} - 0.4	–	V	I _{OH} ≥ -1.4 mA	
		2.4	–	V	I _{OH} ≥ -2 mA	
Output high voltage, POD ¹⁾ = strong		V _{DDP} - 0.4	–	V	I _{OH} ≥ -1.4 mA	
		2.4	–	V	I _{OH} ≥ -2 mA	
Output low voltage		V _{OLA1+} CC	–	0.4	V	I _{OL} ≤ 500 μA; POD ¹⁾ = weak
			–	0.4	V	I _{OL} ≤ 2 mA; POD ¹⁾ = medium
	–		0.4	V	I _{OL} ≤ 2 mA; POD ¹⁾ = strong	
Fall time	t _{FA1+} CC	–	150	ns	C _L = 20 pF; POD ¹⁾ = weak	
		–	50	ns	C _L = 50 pF; POD ¹⁾ = medium	
		–	28	ns	C _L = 50 pF; POD ¹⁾ = strong; edge = slow	
		–	16	ns	C _L = 50 pF; POD ¹⁾ = strong; edge = soft;	
Rise time	t _{RA1+} CC	–	150	ns	C _L = 20 pF; POD ¹⁾ = weak	
		–	50	ns	C _L = 50 pF; POD ¹⁾ = medium	
		–	28	ns	C _L = 50 pF; POD ¹⁾ = strong; edge = slow	
		–	16	ns	C _L = 50 pF; POD ¹⁾ = strong; edge = soft	

1) POD = Pin Out Driver

Electrical Parameters
Table 22 Standard Pads Class_A2

Parameter	Symbol	Values		Unit	Note / Test Condition
		Min.	Max.		
Input Leakage current	I_{OZA2} CC	-6	6	μA	$0\text{ V} \leq V_{IN} < 0.5 \cdot V_{DDP} - 1\text{ V};$ $0.5 \cdot V_{DDP} + 1\text{ V} < V_{IN} \leq V_{DDP}$
		-3	3	μA	$0.5 \cdot V_{DDP} - 1\text{ V} < V_{IN} < 0.5 \cdot V_{DDP} + 1\text{ V}$
Input high voltage	V_{IHA2} SR	$0.6 \times V_{DDP}$	$V_{DDP} + 0.3$	V	max. 3.6 V
Input low voltage	V_{ILA2} SR	-0.3	$0.36 \times V_{DDP}$	V	
Output high voltage, POD = weak	V_{OHA2} CC	$V_{DDP} - 0.4$	–	V	$I_{OH} \geq -400\ \mu\text{A}$
		2.4	–	V	$I_{OH} \geq -500\ \mu\text{A}$
Output high voltage, POD = medium		$V_{DDP} - 0.4$	–	V	$I_{OH} \geq -1.4\ \text{mA}$
		2.4	–	V	$I_{OH} \geq -2\ \text{mA}$
Output high voltage, POD = strong		$V_{DDP} - 0.4$	–	V	$I_{OH} \geq -1.4\ \text{mA}$
		2.4	–	V	$I_{OH} \geq -2\ \text{mA}$
Output low voltage, POD = weak	V_{OLA2} CC	–	0.4	V	$I_{OL} \leq 500\ \mu\text{A}$
Output low voltage, POD = medium		–	0.4	V	$I_{OL} \leq 2\ \text{mA}$
Output low voltage, POD = strong		–	0.4	V	$I_{OL} \leq 2\ \text{mA}$

Electrical Parameters

Table 22 Standard Pads Class_A2

Parameter	Symbol	Values		Unit	Note / Test Condition
		Min.	Max.		
Fall time	t_{FA2} CC	–	150	ns	$C_L = 20$ pF; POD = weak
		–	50	ns	$C_L = 50$ pF; POD = medium
		–	3.7	ns	$C_L = 50$ pF; POD = strong; edge = sharp
		–	7	ns	$C_L = 50$ pF; POD = strong; edge = medium
		–	16	ns	$C_L = 50$ pF; POD = strong; edge = soft
Rise time	t_{RA2} CC	–	150	ns	$C_L = 20$ pF; POD = weak
		–	50	ns	$C_L = 50$ pF; POD = medium
		–	3.7	ns	$C_L = 50$ pF; POD = strong; edge = sharp
		–	7.0	ns	$C_L = 50$ pF; POD = strong; edge = medium
		–	16	ns	$C_L = 50$ pF; POD = strong; edge = soft

Table 23 HIB_IO Class_A1 special Pads

Parameter	Symbol	Values		Unit	Note / Test Condition
		Min.	Max.		
Input leakage current	I_{OZHIB} CC	-500	500	nA	$0\text{ V} \leq V_{IN} \leq V_{BAT}$
Input high voltage	V_{IHIB} SR	$0.6 \times V_{BAT}$	$V_{BAT} + 0.3$	V	max. 3.6 V
Input low voltage	V_{ILIB} SR	-0.3	$0.36 \times V_{BAT}$	V	
Input Hysteresis for HIB_IO pins ¹⁾	$HYSHIB$ CC	$0.1 \times V_{BAT}$	–	V	$V_{BAT} \geq 3.13\text{ V}$
		$0.06 \times V_{BAT}$	–	V	$V_{BAT} < 3.13\text{ V}$
Output high voltage, POD ¹⁾ = medium	V_{OHIB} CC	$V_{BAT} - 0.4$	–	V	$I_{OH} \geq -1.4\text{ mA}$
Output low voltage	V_{OLIB} CC	–	0.4	V	$I_{OL} \leq 2\text{ mA}$
Fall time	t_{FHIB} CC	–	50	ns	$V_{BAT} \geq 3.13\text{ V}$ $C_L = 50\text{ pF}$
		–	100	ns	$V_{BAT} < 3.13\text{ V}$ $C_L = 50\text{ pF}$
Rise time	t_{RHIB} CC	–	50	ns	$V_{BAT} \geq 3.13\text{ V}$ $C_L = 50\text{ pF}$
		–	100	ns	$V_{BAT} < 3.13\text{ V}$ $C_L = 50\text{ pF}$

1) Hysteresis is implemented to avoid metastable states and switching due to internal ground bounce. It can not be guaranteed that it suppresses switching due to external system noise.

3.2.2 Analog to Digital Converters (VADC)

Note: These parameters are not subject to production test, but verified by design and/or characterization.

Table 24 VADC Parameters (Operating Conditions apply)

Parameter	Symbol	Values			Unit	Note / Test Condition
		Min.	Typ.	Max.		
Analog reference voltage ⁵⁾	V_{AREF} SR	$V_{AGND} + 1$	–	$V_{DDA} + 0.05^{1)}$	V	
Analog reference ground ⁵⁾	V_{AGND} SR	$V_{SSM} - 0.05$	–	$V_{AREF} - 1$	V	
Analog reference voltage range ²⁾⁵⁾	$V_{AREF} - V_{AGND}$ SR	1	–	$V_{DDA} + 0.1$	V	
Analog input voltage	V_{AIN} SR	V_{AGND}	–	V_{DDA}	V	
Input leakage at analog inputs ³⁾	I_{OZ1} CC	-100	–	200	nA	$0.03 \times V_{DDA} < V_{AIN} < 0.97 \times V_{DDA}$
		-500	–	100	nA	$0 \text{ V} \leq V_{AIN} \leq 0.03 \times V_{DDA}$
		-100	–	500	nA	$0.97 \times V_{DDA} \leq V_{AIN} \leq V_{DDA}$
Input leakage current at VAREF	I_{OZ2} CC	-1	–	1	μA	$0 \text{ V} \leq V_{AREF} \leq V_{DDA}$
Input leakage current at VAGND	I_{OZ3} CC	-1	–	1	μA	$0 \text{ V} \leq V_{AGND} \leq V_{DDA}$
Internal ADC clock	f_{ADCI} CC	2	–	36	MHz	$V_{DDA} = 3.3 \text{ V}$
Switched capacitance at the analog voltage inputs ⁴⁾	C_{AINSW} CC	–	4	6.5	pF	
Total capacitance of an analog input	C_{AINTOT} CC	–	12	20	pF	
Switched capacitance at the positive reference voltage input ⁵⁾⁶⁾	C_{AREFSW} CC	–	15	30	pF	
Total capacitance of the voltage reference inputs ⁵⁾	$C_{AREFTOT}$ CC	–	20	40	pF	

Electrical Parameters
Table 24 VADC Parameters (Operating Conditions apply)

Parameter	Symbol	Values			Unit	Note / Test Condition
		Min.	Typ.	Max.		
Total Unadjusted Error	TUE_{CC}	-4	–	4	LSB	12-bit resolution; $V_{DDA} = 3.3\text{ V}$; $V_{AREF} = V_{DDA}$ ⁷⁾
Differential Non-Linearity Error ⁸⁾	$EA_{DNL_{CC}}$	-3	–	3	LSB	
Gain Error ⁸⁾	$EA_{GAIN_{CC}}$	-4	–	4	LSB	
Integral Non-Linearity ⁸⁾	$EA_{INL_{CC}}$	-3	–	3	LSB	
Offset Error ⁸⁾	$EA_{OFF_{CC}}$	-4	–	4	LSB	
RMS Noise ⁹⁾	$EN_{RMS_{CC}}$	–	1	2 ¹⁰⁾¹¹⁾	LSB	
Worst case ADC V_{DDA} power supply current per active converter	$I_{DDAA_{CC}}$	–	1.5	2	mA	during conversion $V_{DDP} = 3.6\text{ V}$, $T_J = 150\text{ °C}$
Charge consumption on V_{AREF} per conversion ⁵⁾	$Q_{CONV_{CC}}$	–	30	–	pC	$0\text{ V} \leq V_{AREF} \leq V_{DDA}$ ¹²⁾
ON resistance of the analog input path	$R_{AIN_{CC}}$	–	600	1 200	Ohm	
ON resistance for the ADC test (pull down for AIN7)	$R_{AIN7T_{CC}}$	180	550	900	Ohm	
Resistance of the reference voltage input path	$R_{AREF_{CC}}$	–	700	1 700	Ohm	

- 1) A running conversion may become imprecise in case the normal conditions are violated (voltage overshoot).
- 2) If the analog reference voltage is below V_{DDA} , then the ADC converter errors increase. If the reference voltage is reduced by the factor k ($k < 1$), TUE, DNL, INL, Gain, and Offset errors increase also by the factor $1/k$.
- 3) The leakage current definition is a continuous function, as shown in figure ADCx Analog Inputs Leakage. The numerical values defined determine the characteristic points of the given continuous linear approximation - they do not define step function (see [Figure 12](#)).
- 4) The sampling capacity of the conversion C-network is pre-charged to $V_{AREF}/2$ before the sampling moment. Because of the parasitic elements, the voltage measured at AINx can deviate from $V_{AREF}/2$.
- 5) Applies to AINx, when used as alternate reference input.
- 6) This represents an equivalent switched capacitance. This capacitance is not switched to the reference voltage at once. Instead, smaller capacitances are successively switched to the reference voltage.
- 7) For 10-bit conversions, the errors are reduced to 1/4; for 8-bit conversions, the errors are reduced to 1/16. Never less than ± 1 LSB.
- 8) The sum of DNL/INL/GAIN/OFF errors does not exceed the related total unadjusted error TUE.

Electrical Parameters

- 9) This parameter is valid for soldered devices and requires careful analog board design.
- 10) Resulting worst case combined error is arithmetic combination of TUE and EN_{RMS} .
- 11) Value is defined for one sigma Gauss distribution.
- 12) The resulting current for a conversion can be calculated with $I_{AREF} = Q_{CONV} / t_c$.
The fastest 12-bit post-calibrated conversion of $t_c = 459$ ns results in a typical average current of $I_{AREF} = 65.4$ μ A.

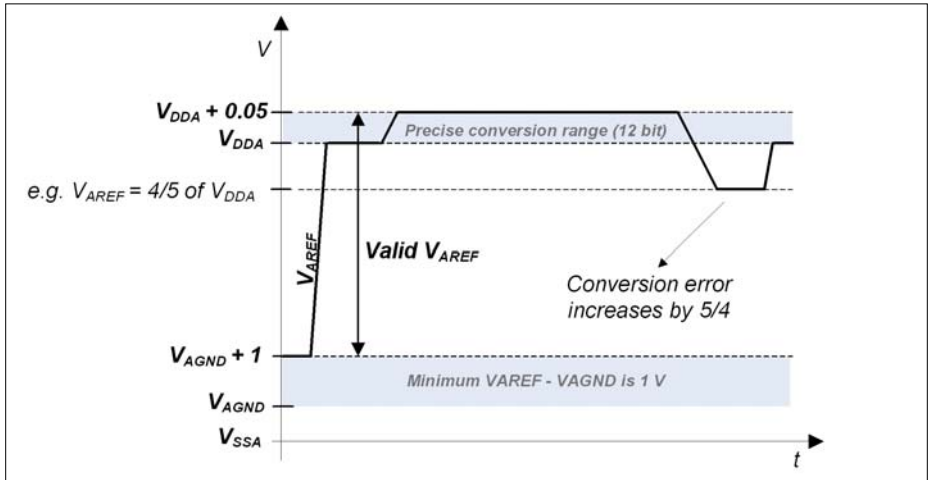

Figure 10 VADC Reference Voltage Range

The power-up calibration of the VADC requires a maximum number of $4 \cdot 352 \cdot f_{ADCI}$ cycles.

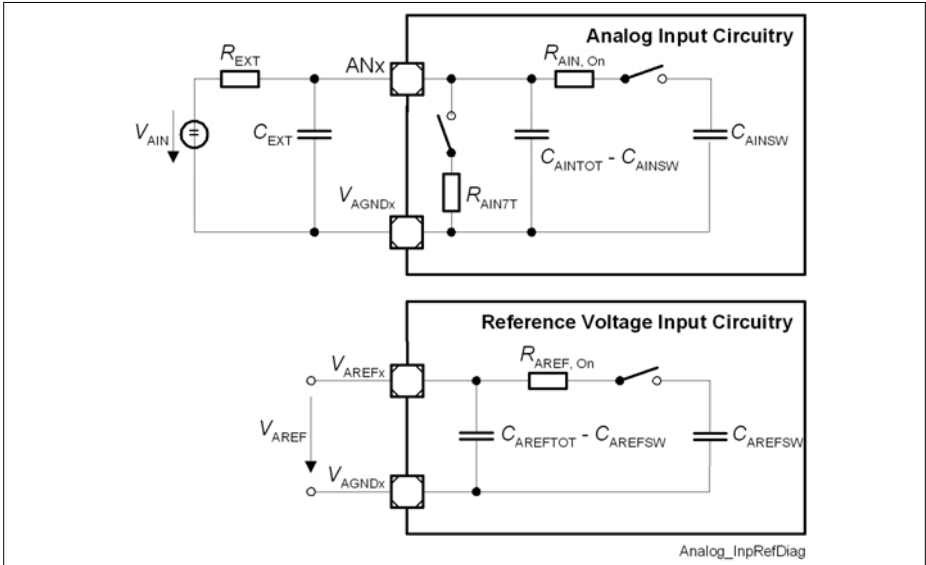

Figure 11 VADC Input Circuits

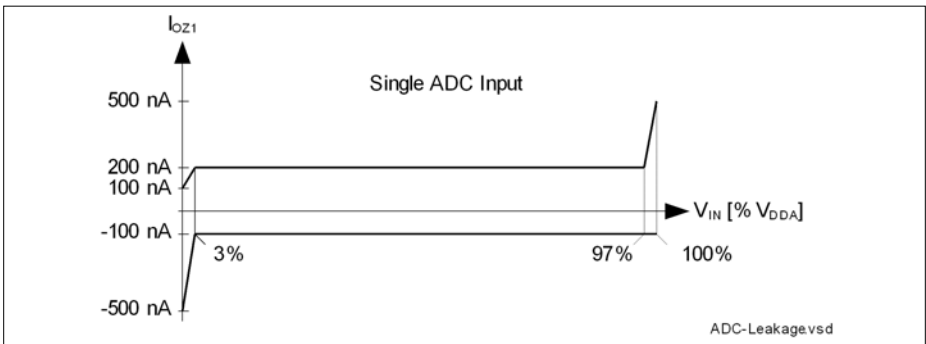

Figure 12 VADC Analog Input Leakage Current

Conversion Time

Table 25 Conversion Time (Operating Conditions apply)

Parameter	Symbol	Values	Unit	Note
Conversion time	t_C CC	$2 \times T_{ADC} + (2 + N + STC + PC + DM) \times T_{ADCI}$	μs	N = 8, 10, 12 for N-bit conversion $T_{ADC} = 1 / f_{PERIPH}$ $T_{ADCI} = 1 / f_{ADCI}$

- STC defines additional clock cycles to extend the sample time
- PC adds two cycles if post-calibration is enabled
- DM adds one cycle for an extended conversion time of the MSB

Conversion Time Examples

System assumptions:

$$f_{ADC} = 144 \text{ MHz i.e. } t_{ADC} = 6.9 \text{ ns, DIVA} = 3, f_{ADCI} = 36 \text{ MHz i.e. } t_{ADCI} = 27.8 \text{ ns}$$

According to the given formulas the following minimum conversion times can be achieved (STC = 0, DM = 0):

12-bit post-calibrated conversion (PC = 2):

$$t_{CN12C} = (2 + 12 + 2) \times t_{ADCI} + 2 \times t_{ADC} = 16 \times 27.8 \text{ ns} + 2 \times 6.9 \text{ ns} = 459 \text{ ns}$$

12-bit uncalibrated conversion:

$$t_{CN12} = (2 + 12) \times t_{ADCI} + 2 \times t_{ADC} = 14 \times 27.8 \text{ ns} + 2 \times 6.9 \text{ ns} = 403 \text{ ns}$$

10-bit uncalibrated conversion:

$$t_{CN10} = (2 + 10) \times t_{ADCI} + 2 \times t_{ADC} = 12 \times 27.8 \text{ ns} + 2 \times 6.9 \text{ ns} = 348 \text{ ns}$$

8-bit uncalibrated:

$$t_{CN8} = (2 + 8) \times t_{ADCI} + 2 \times t_{ADC} = 10 \times 27.8 \text{ ns} + 2 \times 6.9 \text{ ns} = 292 \text{ ns}$$

Electrical Parameters
3.2.3 Digital to Analog Converters (DAC)

Note: These parameters are not subject to production test, but verified by design and/or characterization.

Table 26 DAC Parameters (Operating Conditions apply)

Parameter	Symbol	Values			Unit	Note / Test Condition
		Min.	Typ.	Max.		
RMS supply current	I_{DD} CC	–	2.5	4	mA	per active DAC channel, without load currents of DAC outputs
Resolution	RES CC	–	12	–	Bit	
Update rate	f_{URATE_A} CC	–		2	Msample/s	data rate, where DAC can follow 64 LSB code jumps to ± 1 LSB accuracy
Update rate	f_{URATE_F} CC	–		5	Msample/s	data rate, where DAC can follow 64 LSB code jumps to ± 4 LSB accuracy
Settling time	t_{SETTLE} CC	–	1	2	μ s	at full scale jump, output voltage reaches target value ± 20 LSB
Slew rate	SR CC	2	5	–	V/ μ s	
Minimum output voltage	V_{OUT_MIN} CC	–	0.3	–	V	code value unsigned: 000 _H ; signed: 800 _H
Maximum output voltage	V_{OUT_MAX} CC	–	2.5	–	V	code value unsigned: FFF _H ; signed: 7FF _H
Integral non-linearity	INL CC	-5.5	± 2.5	5.5	LSB	$R_L \geq 5$ kOhm, $C_L \leq 50$ pF
Differential non-linearity	DNL CC	-2	± 1	2	LSB	$R_L \geq 5$ kOhm, $C_L \leq 50$ pF
Offset error	ED_{OFF} CC		± 20		mV	

Electrical Parameters
Table 26 DAC Parameters (Operating Conditions apply) (cont'd)

Parameter	Symbol	Values			Unit	Note / Test Condition
		Min.	Typ.	Max.		
Gain error	ED_{G_IN} CC	-6.5	-1.5	3	%	
Startup time	$t_{STARTUP}$ CC	–	15	30	μs	time from output enabling till code valid ± 16 LSB
3dB Bandwidth of Output Buffer	f_{C1} CC	2.5	5	–	MHz	verified by design
Output sourcing current	I_{OUT_SOURCE} CC	–	-30	–	mA	
Output sinking current	I_{OUT_SINK} CC	–	0.6	–	mA	
Output resistance	R_{OUT} CC	–	50	–	Ohm	
Load resistance	R_L SR	5	–	–	kOhm	
Load capacitance	C_L SR	–	–	50	pF	
Signal-to-Noise Ratio	SNR CC	–	70	–	dB	examination bandwidth < 25 kHz
Total Harmonic Distortion	THD CC	–	70	–	dB	examination bandwidth < 25 kHz
Power Supply Rejection Ratio	$PSRR$ CC	–	56	–	dB	to V_{DDA} verified by design

Conversion Calculation

Unsigned:

$$DACxDATA = 4095 \times (V_{OUT} - V_{OUT_MIN}) / (V_{OUT_MAX} - V_{OUT_MIN})$$

Signed:

$$DACxDATA = 4095 \times (V_{OUT} - V_{OUT_MIN}) / (V_{OUT_MAX} - V_{OUT_MIN}) - 2048$$

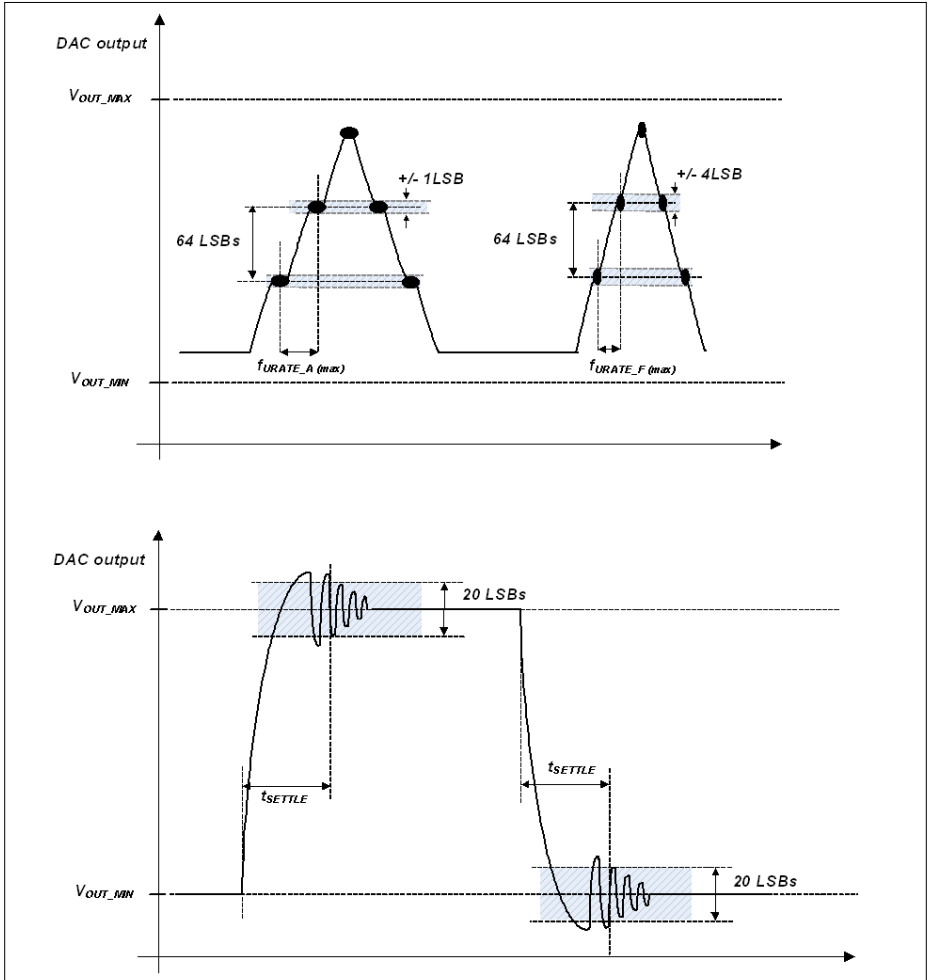

Figure 13 DAC Conversion Examples

3.2.4 Out-of-Range Comparator (ORC)

The Out-of-Range Comparator (ORC) triggers on analog input voltages (V_{AIN}) above the analog reference¹⁾ (V_{AREF}) on selected input pins (GxORCy) and generates a service request trigger (GxORCOUTy).

Note: These parameters are not subject to production test, but verified by design and/or characterization.

The parameters in **Table 27** apply for the maximum reference voltage $V_{AREF} = V_{DDA} + 50 \text{ mV}$.

Table 27 ORC Parameters (Operating Conditions apply)

Parameter	Symbol		Values			Unit	Note / Test Condition
			Min.	Typ.	Max.		
DC Switching Level	V_{ODC}	CC	100	125	210	mV	$V_{AIN} \geq V_{AREF} + V_{ODC}$
Hysteresis	V_{OHYS}	CC	50	–	V_{ODC}	mV	
Detection Delay of a persistent Overvoltage	t_{ODD}	CC	50	–	450	ns	$V_{AIN} \geq V_{AREF} + 210 \text{ mV}$
			45	–	105	ns	$V_{AIN} \geq V_{AREF} + 400 \text{ mV}$
Always detected Overvoltage Pulse	t_{OPDD}	CC	440	–	–	ns	$V_{AIN} \geq V_{AREF} + 210 \text{ mV}$
			90	–	–	ns	$V_{AIN} \geq V_{AREF} + 400 \text{ mV}$
Never detected Overvoltage Pulse	t_{OPDN}	CC	–	–	45	ns	$V_{AIN} \geq V_{AREF} + 210 \text{ mV}$
			–	–	30	ns	$V_{AIN} \geq V_{AREF} + 400 \text{ mV}$
Release Delay	t_{ORD}	CC	65	–	105	ns	$V_{AIN} \leq V_{AREF}$
Enable Delay	t_{OED}	CC	–	100	200	ns	

1) Always the standard VADC reference, alternate references do not apply to the ORC.

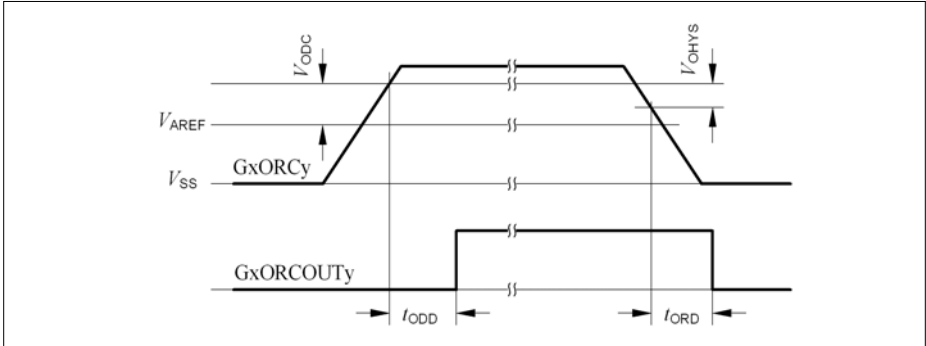

Figure 14 GxORCOUTy Trigger Generation

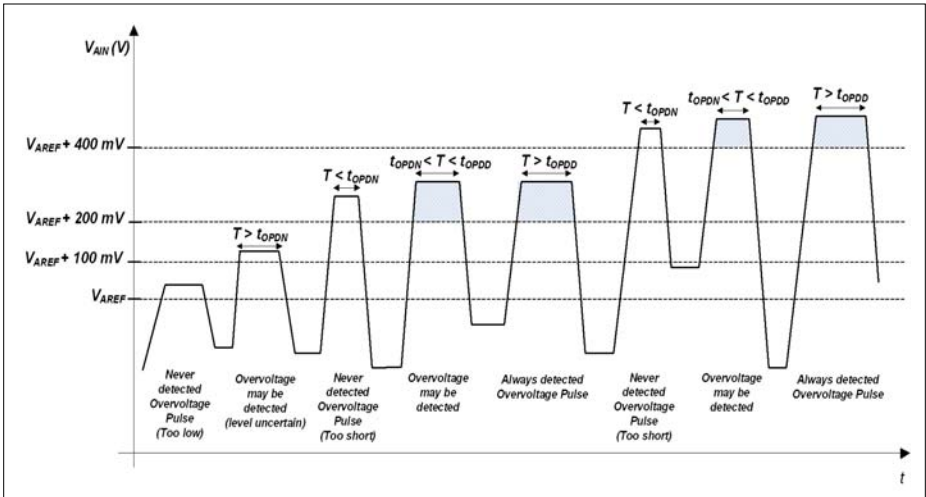

Figure 15 ORC Detection Ranges

3.2.5 Die Temperature Sensor

The Die Temperature Sensor (DTS) measures the junction temperature T_J .

Note: These parameters are not subject to production test, but verified by design and/or characterization.

Table 28 Die Temperature Sensor Parameters

Parameter	Symbol	Values			Unit	Note / Test Condition
		Min.	Typ.	Max.		
Temperature sensor range	T_{SR} SR	-40	–	150	°C	
Linearity Error (to the below defined formula)	ΔT_{LE} CC	–	±1	–	°C	per $\Delta T_J \leq 30$ °C
Offset Error	ΔT_{OE} CC	–	±6	–	°C	$\Delta T_{OE} = T_J - T_{DTS}$ $V_{DDP} \leq 3.3$ V ¹⁾
Measurement time	t_M CC	–	–	100	µs	
Start-up time after reset inactive	t_{TSST} SR	–	–	10	µs	

1) At $V_{DDP_max} = 3.63$ V the typical offset error increases by an additional $\Delta T_{OE} = \pm 1$ °C.

The following formula calculates the temperature measured by the DTS in [°C] from the RESULT bit field of the DTSSTAT register.

$$\text{Temperature } T_{DTS} = (\text{RESULT} - 605) / 2.05 \text{ [°C]}$$

This formula and the values defined in **Table 28** apply with the following calibration values:

- DTSCON.BGTRIM = δ_H
- DTSCON.REFTRIM = 4_H

3.2.6 USB OTG Interface DC Characteristics

The Universal Serial Bus (USB) Interface is compliant to the USB Rev. 2.0 Specification and the OTG Specification Rev. 1.3. High-Speed Mode is not supported.

Note: These parameters are not subject to production test, but verified by design and/or characterization.

Table 29 USB OTG VBUS and ID Parameters (Operating Conditions apply)

Parameter	Symbol	Values			Unit	Note / Test Condition
		Min.	Typ.	Max.		
VBUS input voltage range	V_{IN} CC	0.0	–	5.25	V	
A-device VBUS valid threshold	V_{B1} CC	4.4	–	–	V	
A-device session valid threshold	V_{B2} CC	0.8	–	2.0	V	
B-device session valid threshold	V_{B3} CC	0.8	–	4.0	V	
B-device session end threshold	V_{B4} CC	0.2	–	0.8	V	
VBUS input resistance to ground	R_{VBUS_IN} CC	40	–	100	kOhm	
B-device VBUS pull-up resistor	R_{VBUS_PU} CC	281	–	–	Ohm	Pull-up voltage = 3.0 V
B-device VBUS pull-down resistor	R_{VBUS_PD} CC	656	–	–	Ohm	
USB.ID pull-up resistor	R_{UID_PU} CC	14	–	25	kOhm	
VBUS input current	I_{VBUS_IN} CC	–	–	150	μ A	$0\text{ V} \leq V_{IN} \leq 5.25\text{ V}$: $T_{AVG} = 1\text{ ms}$

Electrical Parameters
Table 30 USB OTG Data Line (USB_DP, USB_DM) Parameters (Operating Conditions apply)

Parameter	Symbol	Values			Unit	Note / Test Condition
		Min.	Typ.	Max.		
Input low voltage	V_{IL} SR	–	–	0.8	V	
Input high voltage (driven)	V_{IH} SR	2.0	–	–	V	
Input high voltage (floating) ¹⁾	V_{IHZ} SR	2.7	–	3.6	V	
Differential input sensitivity	V_{DIS} CC	0.2	–	–	V	
Differential common mode range	V_{CM} CC	0.8	–	2.5	V	
Output low voltage	V_{OL} CC	0.0	–	0.3	V	1.5 kOhm pull-up to 3.6 V
Output high voltage	V_{OH} CC	2.8	–	3.6	V	15 kOhm pull-down to 0 V
DP pull-up resistor (idle bus)	R_{PUI} CC	900	–	1 575	Ohm	
DP pull-up resistor (upstream port receiving)	R_{PUA} CC	1 425	–	3 090	Ohm	
DP, DM pull-down resistor	R_{PD} CC	14.25	–	24.8	kOhm	
Input impedance DP, DM	Z_{INP} CC	300	–	–	kOhm	$0 V \leq V_{IN} \leq V_{DDP}$
Driver output resistance DP, DM	Z_{DRV} CC	28	–	44	Ohm	

1) Measured at A-connector with 1.5 kOhm \pm 5% to 3.3 V \pm 0.3 V connected to USB_DP or USB_DM and at B-connector with 15 kOhm \pm 5% to ground connected to USB_DP and USB_DM.

3.2.7 Oscillator Pins

Note: It is strongly recommended to measure the oscillation allowance (negative resistance) in the final target system (layout) to determine the optimal parameters for the oscillator operation. Please refer to the limits specified by the crystal or ceramic resonator supplier.

Note: These parameters are not subject to production test, but verified by design and/or characterization.

The oscillator pins can be operated with an external crystal (see [Figure 16](#)) or in direct input mode (see [Figure 17](#)).

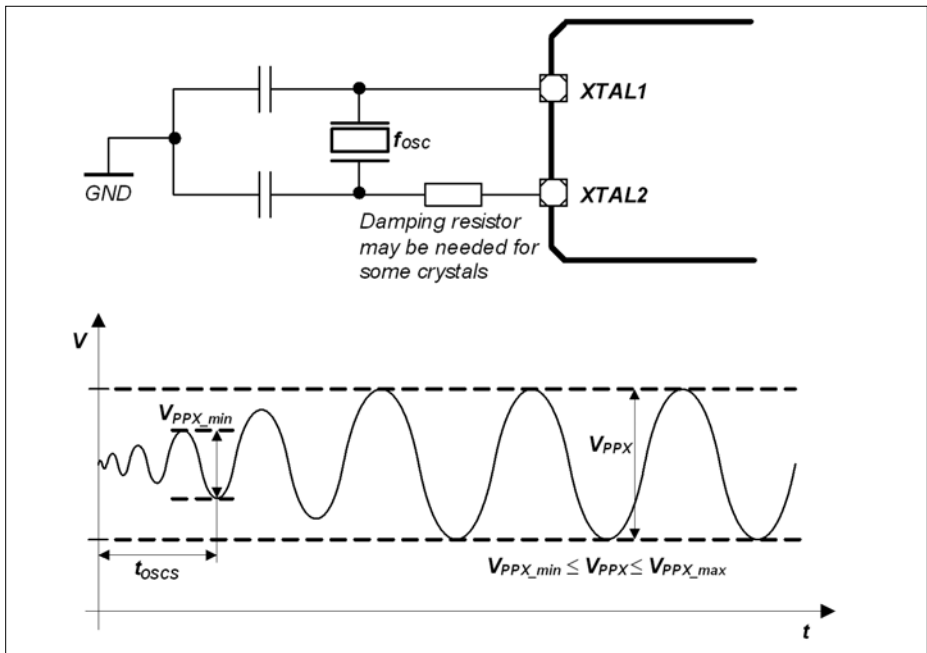

Figure 16 Oscillator in Crystal Mode

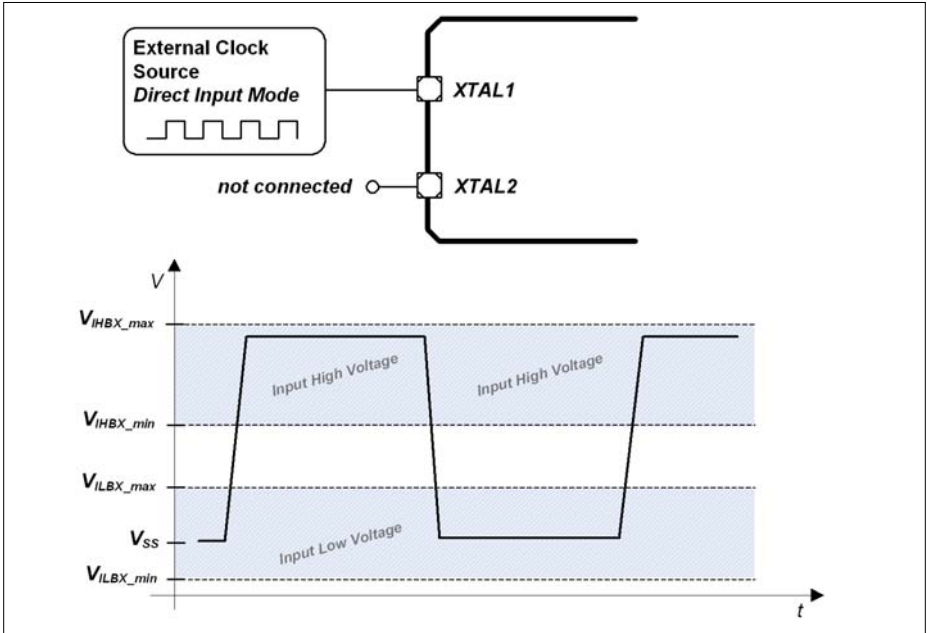

Figure 17 Oscillator in Direct Input Mode

Table 31 OSC_XTAL Parameters

Parameter	Symbol	Values			Unit	Note / Test Condition
		Min.	Typ.	Max.		
Input frequency	f_{OSC} SR	4	–	40	MHz	Direct Input Mode selected
		4	–	25	MHz	External Crystal Mode selected
Oscillator start-up time ¹⁾²⁾	t_{OSCS} CC	–	–	10	ms	
Input voltage at XTAL1	V_{IX} SR	-0.5	–	$V_{\text{DDP}} + 0.5$	V	
Input amplitude (peak-to-peak) at XTAL1 ²⁾³⁾	V_{PPX} SR	$0.4 \times V_{\text{DDP}}$	–	$V_{\text{DDP}} + 1.0$	V	
Input high voltage at XTAL1 ⁴⁾	V_{IHBX} SR	1.0	–	$V_{\text{DDP}} + 0.5$	V	
Input low voltage at XTAL1 ⁴⁾	V_{ILBX} SR	-0.5	–	0.4	V	
Input leakage current at XTAL1	I_{ILX1} CC	-100	–	100	nA	Oscillator power down $0 \text{ V} \leq V_{\text{IX}} \leq V_{\text{DDP}}$

1) t_{OSCS} is defined from the moment the oscillator is enabled with SCU_OSCHPCTRL.MODE until the oscillations reach an amplitude at XTAL1 of $0.4 \times V_{\text{DDP}}$.

2) The external oscillator circuitry must be optimized by the customer and checked for negative resistance and amplitude as recommended and specified by crystal suppliers.

3) If the shaper unit is enabled and not bypassed.

4) If the shaper unit is bypassed, dedicated DC-thresholds have to be met.

Table 32 RTC_XTAL Parameters

Parameter	Symbol	Values			Unit	Note / Test Condition
		Min.	Typ.	Max.		
Input frequency	f_{OSC} SR	–	32.768	–	kHz	
Oscillator start-up time ¹⁾²⁾³⁾	t_{OSCS} CC	–	–	5	s	
Input voltage at RTC_XTAL1	V_{IX} SR	-0.3	–	$V_{BAT} + 0.3$	V	
Input amplitude (peak-to-peak) at RTC_XTAL1 ²⁾⁴⁾	V_{PPX} SR	0.4	–	–	V	
Input high voltage at RTC_XTAL1 ⁵⁾	V_{IHBX} SR	$0.6 \times V_{BAT}$	–	$V_{BAT} + 0.3$	V	
Input low voltage at RTC_XTAL1 ⁵⁾	V_{ILBX} SR	-0.3	–	$0.36 \times V_{BAT}$	V	
Input Hysteresis for RTC_XTAL1 ⁵⁾⁶⁾	V_{HYSX} CC	$0.1 \times V_{BAT}$	–	–	V	$3.0 \text{ V} \leq V_{BAT} < 3.6 \text{ V}$
		$0.03 \times V_{BAT}$	–	–	V	$V_{BAT} < 3.0 \text{ V}$
Input leakage current at RTC_XTAL1	I_{ILX1} CC	-100	–	100	nA	Oscillator power down $0 \text{ V} \leq V_{IX} \leq V_{BAT}$

- t_{OSCS} is defined from the moment the oscillator is enabled by the user with SCU_OSCULCTRL.MODE until the oscillations reach an amplitude at RTC_XTAL1 of 400 mV.
- The external oscillator circuitry must be optimized by the customer and checked for negative resistance and amplitude as recommended and specified by crystal suppliers.
- For a reliable start of the oscillation in crystal mode it is required that $V_{BAT} \geq 3.0 \text{ V}$. A running oscillation is maintained across the full V_{BAT} voltage range.
- If the shaper unit is enabled and not bypassed.
- If the shaper unit is bypassed, dedicated DC-thresholds have to be met.
- Hysteresis is implemented to avoid metastable states and switching due to internal ground bounce. It can not be guaranteed that it suppresses switching due to external system noise.

3.2.8 Power Supply Current

The total power supply current defined below consists of a leakage and a switching component.

Application relevant values are typically lower than those given in the following tables, and depend on the customer's system operating conditions (e.g. thermal connection or used application configurations).

Note: These parameters are not subject to production test, but verified by design and/or characterization.

If not stated otherwise, the operating conditions for the parameters in the following table are:

$$V_{DDP} = 3.3 \text{ V}, T_A = 25 \text{ }^\circ\text{C}$$

Table 33 Power Supply Parameters

Parameter	Symbol	Values			Unit	Note / Test Condition
		Min.	Typ.	Max.		
Active supply current ¹⁾¹¹⁾ Peripherals enabled Frequency: $f_{CPU} / f_{PERIPH} / f_{CCU}$ in MHz	I_{DDPA} CC	–	135	–	mA	144 / 144 / 144
		–	125	–		144 / 72 / 72
		–	97	–		72 / 72 / 144
		–	80	–		24 / 24 / 24
		–	68	–		1 / 1 / 1
Active supply current Code execution from RAM Flash in Sleep mode	I_{DDPA} CC	–	108	–	mA	144 / 144 / 144
		–	98	–		144 / 72 / 72
Active supply current ²⁾ Peripherals disabled Frequency: $f_{CPU} / f_{PERIPH} / f_{CCU}$ in MHz	I_{DDPA} CC	–	86	–	mA	144 / 144 / 144
		–	85	–		144 / 72 / 72
		–	70	–		72 / 72 / 144
		–	55	–		24 / 24 / 24
		–	50	–		1 / 1 / 1
Sleep supply current ³⁾ Peripherals enabled Frequency: $f_{CPU} / f_{PERIPH} / f_{CCU}$ in MHz	I_{DDPS} CC	–	127	–	mA	144 / 144 / 144
		–	115	–		144 / 72 / 72
		–	93	–		72 / 72 / 144
		–	57	–		24 / 24 / 24
		–	47	–		1 / 1 / 1
$f_{CPU} / f_{PERIPH} / f_{CCU}$ in kHz		–	48	–		100 / 100 / 100

Electrical Parameters
Table 33 Power Supply Parameters

Parameter	Symbol	Values			Unit	Note / Test Condition
		Min.	Typ.	Max.		
Sleep supply current ⁴⁾ Peripherals disabled Frequency: $f_{CPU} / f_{PERIPH} / f_{CCU}$ in MHz	I_{DDPS} CC	-	77	-	mA	144 / 144 / 144
		-	76	-		144 / 72 / 72
		-	65	-		72 / 72 / 144
		-	53	-		24 / 24 / 24
		-	46	-		1 / 1 / 1
		-	47	-		100 / 100 / 100
$f_{CPU} / f_{PERIPH} / f_{CCU}$ in kHz Deep Sleep supply current ⁵⁾ Flash in Sleep mode Frequency: $f_{CPU} / f_{PERIPH} / f_{CCU}$ in MHz $f_{CPU} / f_{PERIPH} / f_{CCU}$ in kHz	I_{DDPD} CC	-	11	-	mA	24 / 24 / 24
		-	7.0	-		4 / 4 / 4
		-	6.6	-		1 / 1 / 1
		-	7.6	-		100 / 100 / 100 ⁶⁾
Hibernate supply current RTC on ⁷⁾	I_{DDPH} CC	-	8.7	-	μ A	$V_{BAT} = 3.3$ V
		-	6.5	-		$V_{BAT} = 2.4$ V
		-	5.7	-		$V_{BAT} = 2.0$ V
Hibernate supply current RTC off ⁸⁾	I_{DDPH} CC	-	8.0	-	μ A	$V_{BAT} = 3.3$ V
		-	6.0	-		$V_{BAT} = 2.4$ V
		-	5.0	-		$V_{BAT} = 2.0$ V
Hibernate off ⁹⁾	I_{DDPH} CC	-	4.4	-	μ A	$V_{BAT} = 3.3$ V
		-	3.5	-		$V_{BAT} = 2.4$ V
		-	3.1	-		$V_{BAT} = 2.0$ V
Worst case active supply current ¹⁰⁾	I_{DDPA} CC	-	-	250 ¹¹⁾	mA	$V_{DDP} = 3.6$ V, $T_J = 150$ °C
V_{DDA} power supply current	I_{DDA} CC	-	-	- ¹²⁾	mA	
I_{DDP} current at PORST Low	I_{DDP_PORST} CC	-	5	10	mA	$V_{DDP} = 3.3$ V, $T_J = 25$ °C
		-	13	55	mA	$V_{DDP} = 3.6$ V, $T_J = 150$ °C
Power Dissipation	P_{DISS} CC	-	-	1.4	W	$V_{DDP} = 3.6$ V, $T_J = 150$ °C

Electrical Parameters

Table 33 Power Supply Parameters

Parameter	Symbol	Values			Unit	Note / Test Condition
		Min.	Typ.	Max.		
Wake-up time from Sleep to Active mode	t_{SSA} CC	–	6	–	cycles	
Wake-up time from Deep Sleep to Active mode		–	–	–	ms	Defined by the wake-up of the Flash module, see “ Flash Memory Parameters ”
Wake-up time from Hibernate mode		–	–	–	ms	Wake-up via power-on reset event, see “ Power-Up and Supply Monitoring ”

- 1) CPU executing code from Flash, all peripherals idle.
- 2) CPU executing code from Flash.
- 3) CPU in sleep, all peripherals idle, Flash in Active mode.
- 4) CPU in sleep, Flash in Active mode.
- 5) CPU in sleep, peripherals disabled, after wake-up code execution from RAM.
- 6) To wake-up the Flash from its Sleep mode, $f_{CPU} \geq 1$ MHz is required.
- 7) OSC_ULP operating with external crystal on RTC_XTAL
- 8) OSC_ULP off, Hibernate domain operating with OSC_S1 clock
- 9) V_{BAT} supplied, but Hibernate domain not started; for example state after factory assembly
- 10) Test Power Loop: $f_{SYS} = 144$ MHz, CPU executing benchmark code from Flash, all CCUs in 100kHz timer mode, all ADC groups in continuous conversion mode, USICs as SPI in internal loop-back mode, CAN in 500kHz internal loop-back mode, interrupt triggered DMA block transfers to parity protected RAMs and FCE, DTS measurements and FPU calculations.
The power consumption of each customer application will most probably be lower than this value, but must be evaluated separately.
- 11) I_{DDP} decreases typically by approximately 5 mA when f_{SYS} decreases by 10 MHz, at constant T_J
- 12) Sum of currents of all active converters (ADC and DAC)

Peripheral Idle Currents

Default test conditions:

- f_{sys} and derived clocks at 144 MHz
- $V_{DDP} = 3.3\text{ V}$, $T_a = 25\text{ °C}$
- all peripherals are held in reset (see the PRSTAT registers in the Reset Control Unit of the SCU)
- the peripheral clocks are disabled (see CGATSTAT registers in the Clock Control Unit of the SCU)
- no I/O activity

The given values are a result of differential measurements with asserted and deasserted peripheral reset as well as disabled and enabled clock of the peripheral under test.

The tested peripheral is left in the state after the peripheral reset is deasserted, no further initialisation or configuration is done. E.g. no timer is running in the CCUs, no communication active in the USICs, etc.

Table 34 Peripheral Idle Currents

Parameter	Symbol	Values			Unit	Note / Test Condition
		Min.	Typ.	Max.		
PORTS FCE WDT	$I_{PER\ CC}$	–	≤ 0.3	–	mA	
MultiCAN ERU LEDTSCU0 ETH CCU4x ¹⁾ , CCU8x ¹⁾		–	≤ 1.0	–		
DAC (digital) ²⁾		–	1.3	–		
USICx SDMMC		–	3.0	–		
VADC (digital) ²⁾		–	4.5	–		
DMA0, USB, EtherCAT		–	6.0	–		

1) Enabling the f_{CCU} clock for the CCU4x/CCU8x modules adds approximately $I_{PER} = 4.8\text{ mA}$, disregarding which and how many of those peripherals are enabled.

2) The current consumption of the analog components are given in the dedicated Data Sheet sections of the respective peripheral.

3.2.9 Flash Memory Parameters

Note: These parameters are not subject to production test, but verified by design and/or characterization.

Table 35 Flash Memory Parameters

Parameter	Symbol	Values			Unit	Note / Test Condition
		Min.	Typ.	Max.		
Erase Time per 256 Kbyte Sector	t_{ERP} CC	–	5	5.5	s	
Erase Time per 64 Kbyte Sector	t_{ERP} CC	–	1.2	1.4	s	
Erase Time per 16 Kbyte Logical Sector	t_{ERP} CC	–	0.3	0.4	s	
Program time per page ¹⁾	t_{PRP} CC	–	5.5	11	ms	
Erase suspend delay	t_{FL_ErSusp} CC	–	–	15	ms	
Wait time after margin change	$t_{FL_MarginDel}$ CC	10	–	–	μ s	
Wake-up time	t_{WU} CC	–	–	270	μ s	
Read access time	t_a CC	22	–	–	ns	For operation with $1/f_{CPU} < t_a$ wait states must be configured ²⁾
Data Retention Time, Physical Sector ³⁾⁴⁾	t_{RET} CC	20	–	–	years	Max. 1000 erase/program cycles
Data Retention Time, Logical Sector ³⁾⁴⁾	t_{RETL} CC	20	–	–	years	Max. 100 erase/program cycles
Data Retention Time, User Configuration Block (UCB) ³⁾⁴⁾	t_{RTU} CC	20	–	–	years	Max. 4 erase/program cycles per UCB
Endurance on 64 Kbyte Physical Sector PS4	N_{EPS4} CC	10000	–	–	cycles	Cycling distributed over life time ⁵⁾

Electrical Parameters

- 1) In case the Program Verify feature detects weak bits, these bits will be programmed once more. The reprogramming takes an additional time of 5.5 ms.
- 2) The following formula applies to the wait state configuration: $FCON.WSPFLASH \times (1 / f_{CPU}) \geq t_a$.
- 3) Storage and inactive time included.
- 4) Values given are valid for an average weighted junction temperature of $T_J = 110^\circ\text{C}$.
- 5) Only valid with robust EEPROM emulation algorithm, equally cycling the logical sectors. For more details see the Reference Manual.

3.3 AC Parameters

3.3.1 Testing Waveforms

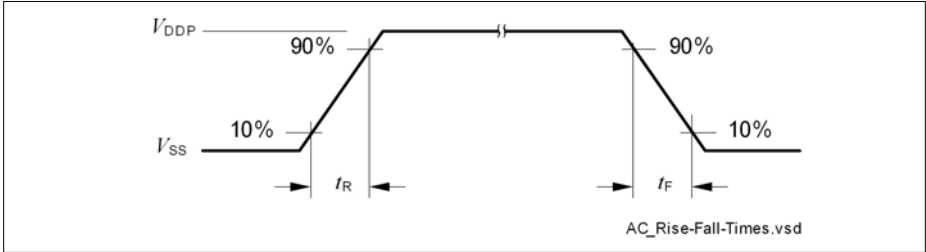

Figure 18 Rise/Fall Time Parameters

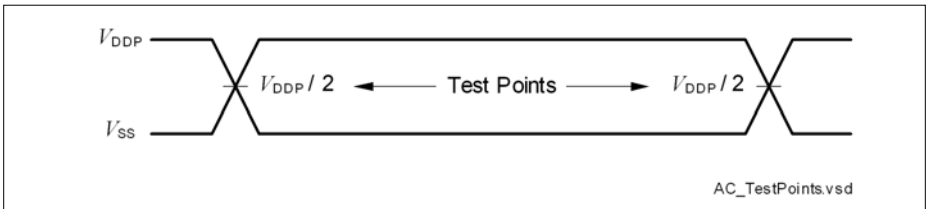

Figure 19 Testing Waveform, Output Delay

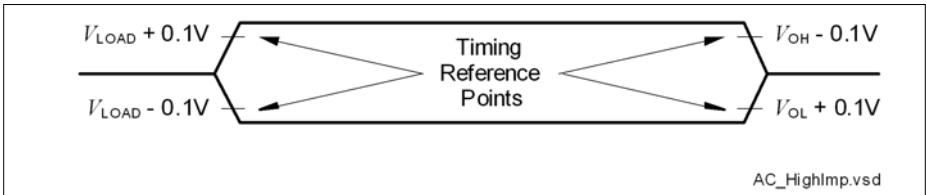

Figure 20 Testing Waveform, Output High Impedance

3.3.2 Power-Up and Supply Monitoring

$\overline{\text{PORST}}$ is always asserted when V_{DDP} and/or V_{DDC} violate the respective thresholds.

Note: These parameters are not subject to production test, but verified by design and/or characterization.

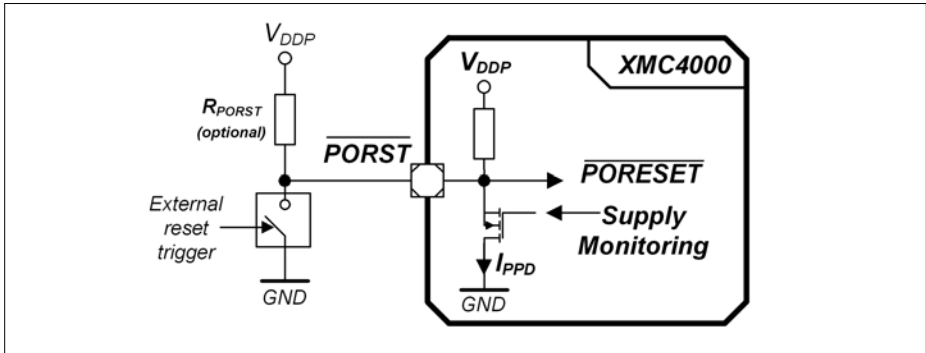

Figure 21 $\overline{\text{PORST}}$ Circuit

Table 36 Supply Monitoring Parameters

Parameter	Symbol	Values			Unit	Note / Test Condition
		Min.	Typ.	Max.		
Digital supply voltage reset threshold	V_{POR} CC	2.79 ¹⁾	–	3.05 ²⁾	V	3)
Core supply voltage reset threshold	V_{PV} CC	–	–	1.17	V	
V_{DDP} voltage to ensure defined pad states	V_{DDPPA} CC	–	1.0	–	V	
$\overline{\text{PORST}}$ rise time	t_{PR} SR	–	–	2	μs	4)
Startup time from power-on reset with code execution from Flash	t_{SSW} CC	–	2.5	3.5	ms	Time to the first user code instruction
V_{DDC} ramp up time	t_{VCR} CC	–	550	–	μs	Ramp up after power-on or after a reset triggered by a violation of V_{POR} or V_{PV}

1) Minimum threshold for reset assertion.

Electrical Parameters

- 2) Maximum threshold for reset deassertion.
- 3) The V_{DDP} monitoring has a typical hysteresis of $V_{PORHYS} = 180\text{ mV}$.
- 4) If t_{PR} is not met, low spikes on $\overline{\text{PORST}}$ may be seen during start up (e.g. reset pulses generated by the supply monitoring due to a slow ramping V_{DDP}).

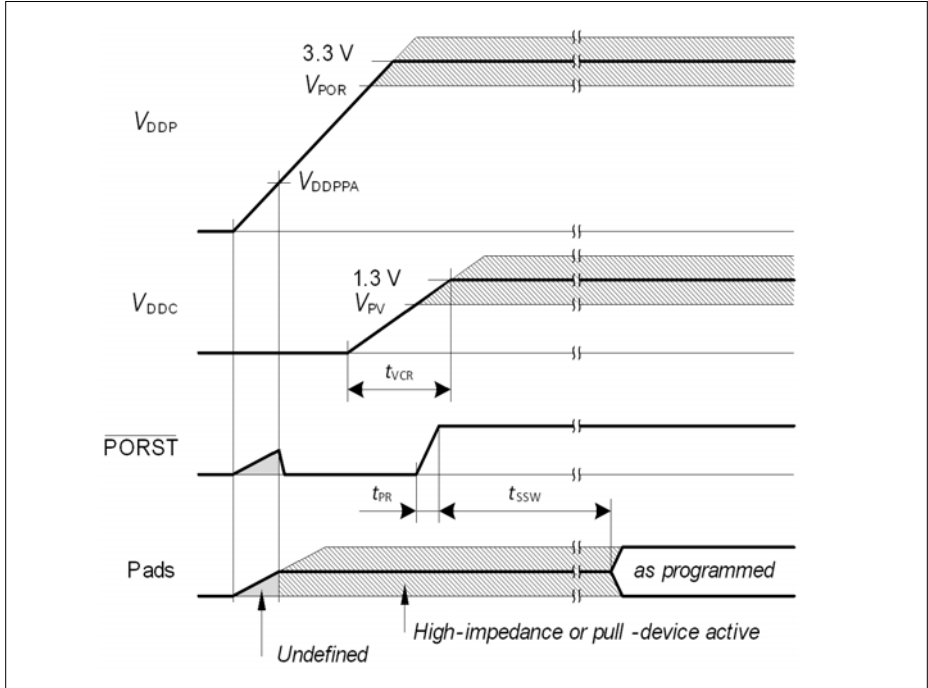

Figure 22 Power-Up Behavior

3.3.3 Power Sequencing

While starting up and shutting down as well as when switching power modes of the system it is important to limit the current load steps. A typical cause for such load steps is changing the CPU frequency f_{CPU} . Load steps exceeding the below defined values may cause a power on reset triggered by the supply monitor.

Note: These parameters are not subject to production test, but verified by design and/or characterization.

Table 37 Power Sequencing Parameters

Parameter	Symbol	Values			Unit	Note / Test Condition
		Min.	Typ.	Max.		
Positive Load Step Current	ΔI_{PLS} SR	-	-	50	mA	Load increase on V_{DDP} $\Delta t \leq 10$ ns
Negative Load Step Current	ΔI_{NLS} SR	-	-	150	mA	Load decrease on V_{DDP} $\Delta t \leq 10$ ns
V_{DDC} Voltage Over- / Undershoot from Load Step	ΔV_{LS} CC	-	-	± 100	mV	For maximum positive or negative load step
Positive Load Step Settling Time	t_{PLSS} SR	50	-	-	μs	
Negative Load Step Settling Time	t_{NLSS} SR	100	-	-	μs	
External Buffer Capacitor on V_{DDC}	C_{EXT} SR	-	10	-	μF	In addition $C = 100$ nF capacitor on each V_{DDC} pin

Positive Load Step Examples

System assumptions:

$f_{\text{CPU}} = f_{\text{SYS}}$, target frequency $f_{\text{CPU}} = 144$ MHz, main PLL $f_{\text{VCO}} = 288$ MHz, stepping done by K2 divider, t_{PLSS} between individual steps:

24 MHz - 48 MHz - 72 MHz - 96 MHz - 144 MHz (K2 steps 12 - 6 - 4 - 3 - 2)

24 MHz - 48 MHz - 96 MHz - 144 MHz (K2 steps 12 - 6 - 3 - 2)

24 MHz - 72 MHz - 144 MHz (K2 steps 12 - 4 - 2)

3.3.4 Phase Locked Loop (PLL) Characteristics

Note: These parameters are not subject to production test, but verified by design and/or characterization.

Main and USB PLL

Table 38 PLL Parameters

Parameter	Symbol	Values			Unit	Note / Test Condition
		Min.	Typ.	Max.		
Accumulated Jitter	D_P CC	–	–	±5	ns	accumulated over 300 cycles $f_{SYS} = 144$ MHz
Duty Cycle ¹⁾	D_{DC} CC	46	50	54	%	Low pulse to total period, assuming an ideal input clock source
PLL base frequency	$f_{PLLBASE}$ CC	30	–	140	MHz	
VCO input frequency	f_{REF} CC	4	–	16	MHz	
VCO frequency range	f_{VCO} CC	260	–	520	MHz	
PLL lock-in time	t_L CC	–	–	400	μs	

1) 50% for even K2 divider values, $50 \pm (10/K2)$ for odd K2 divider values.

3.3.5 Internal Clock Source Characteristics

Note: These parameters are not subject to production test, but verified by design and/or characterization.

Fast Internal Clock Source

Table 39 Fast Internal Clock Parameters

Parameter	Symbol	Values			Unit	Note / Test Condition
		Min.	Typ.	Max.		
Nominal frequency	f_{OFINC} CC	–	36.5	–	MHz	not calibrated
		–	24	–	MHz	calibrated
Accuracy	Δf_{OFI} CC	-0.5	–	0.5	%	automatic calibration ¹⁾²⁾
		-15	–	15	%	factory calibration, $V_{\text{DDP}} = 3.3 \text{ V}$
		-25	–	25	%	no calibration, $V_{\text{DDP}} = 3.3 \text{ V}$
		-7	–	7	%	Variation over voltage range ³⁾ $3.13 \text{ V} \leq V_{\text{DDP}} \leq 3.63 \text{ V}$
Start-up time	t_{OFIS} CC	–	50	–	μs	

1) Error in addition to the accuracy of the reference clock.

2) Automatic calibration compensates variations of the temperature and in the V_{DDP} supply voltage.

3) Deviations from the nominal V_{DDP} voltage induce an additional error to the uncalibrated and/or factory calibrated oscillator frequency.

Electrical Parameters

Slow Internal Clock Source

Table 40 Slow Internal Clock Parameters

Parameter	Symbol	Values			Unit	Note / Test Condition
		Min.	Typ.	Max.		
Nominal frequency	f_{OSI} CC	–	32.768	–	kHz	
Accuracy	Δf_{OSI} CC	-4	–	4	%	$V_{BAT} = \text{const.}$ $0\text{ }^{\circ}\text{C} \leq T_A \leq 85\text{ }^{\circ}\text{C}$
		-5	–	5	%	$V_{BAT} = \text{const.}$ $T_A < 0\text{ }^{\circ}\text{C}$ or $T_A > 85\text{ }^{\circ}\text{C}$
		-5	–	5	%	$2.4\text{ V} \leq V_{BAT}$, $T_A = 25\text{ }^{\circ}\text{C}$
		-10	–	10	%	$1.95\text{ V} \leq V_{BAT} < 2.4\text{ V}$, $T_A = 25\text{ }^{\circ}\text{C}$
Start-up time	t_{OSIS} CC	–	50	–	μs	

3.3.6 JTAG Interface Timing

The following parameters are applicable for communication through the JTAG debug interface. The JTAG module is fully compliant with IEEE1149.1-2000.

Note: These parameters are not subject to production test, but verified by design and/or characterization.

Note: Operating conditions apply.

Table 41 JTAG Interface Timing Parameters

Parameter	Symbol	Values			Unit	Note / Test Condition
		Min.	Typ.	Max.		
TCK clock period	t_1 SR	25	–	–	ns	
TCK high time	t_2 SR	10	–	–	ns	
TCK low time	t_3 SR	10	–	–	ns	
TCK clock rise time	t_4 SR	–	–	4	ns	
TCK clock fall time	t_5 SR	–	–	4	ns	
TDI/TMS setup to TCK rising edge	t_6 SR	6	–	–	ns	
TDI/TMS hold after TCK rising edge	t_7 SR	6	–	–	ns	
TDO valid after TCK falling edge ¹⁾ (propagation delay)	t_8 CC	–	–	13	ns	$C_L = 50$ pF
		3	–	–	ns	$C_L = 20$ pF
TDO hold after TCK falling edge ¹⁾	t_{18} CC	2	–	–	ns	
TDO high imped. to valid from TCK falling edge ¹⁾²⁾	t_9 CC	–	–	14	ns	$C_L = 50$ pF
TDO valid to high imped. from TCK falling edge ¹⁾	t_{10} CC	–	–	13.5	ns	$C_L = 50$ pF

1) The falling edge on TCK is used to generate the TDO timing.

2) The setup time for TDO is given implicitly by the TCK cycle time.

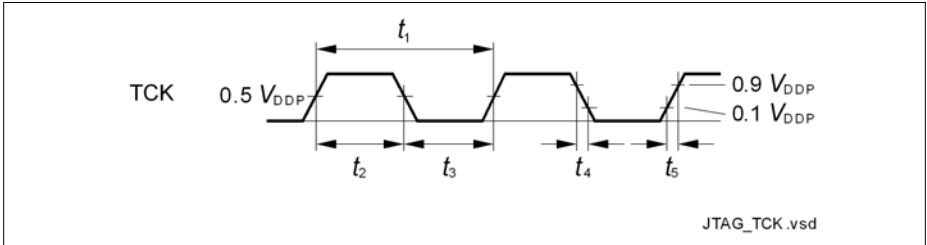

Figure 23 Test Clock Timing (TCK)

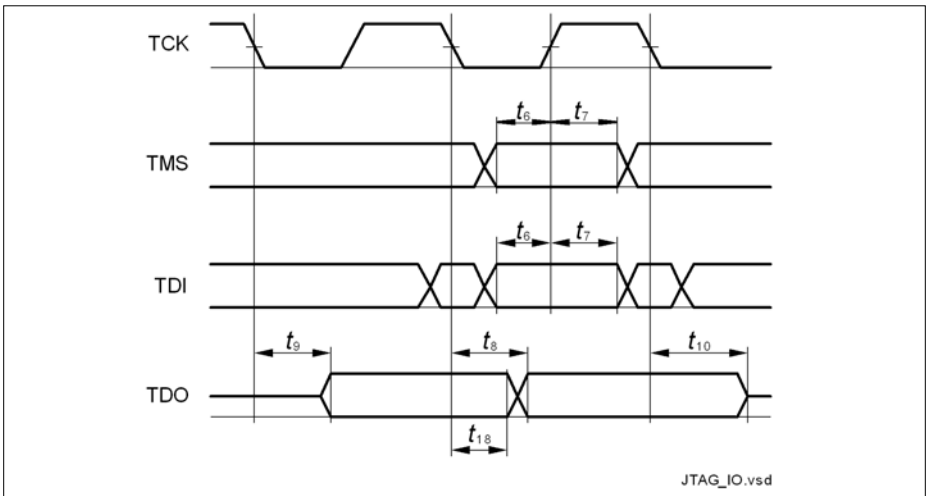

Figure 24 JTAG Timing

3.3.7 Serial Wire Debug Port (SW-DP) Timing

The following parameters are applicable for communication through the SW-DP interface.

Note: These parameters are not subject to production test, but verified by design and/or characterization.

Note: Operating conditions apply.

Table 42 SWD Interface Timing Parameters (Operating Conditions apply)

Parameter	Symbol		Values			Unit	Note / Test Condition
			Min.	Typ.	Max.		
SWDCLK clock period	t_{SC}	SR	25	–	–	ns	$C_L = 30$ pF
			40	–	–	ns	$C_L = 50$ pF
SWDCLK high time	t_1	SR	10	–	500000	ns	
SWDCLK low time	t_2	SR	10	–	500000	ns	
SWDIO input setup to SWDCLK rising edge	t_3	SR	6	–	–	ns	
SWDIO input hold after SWDCLK rising edge	t_4	SR	6	–	–	ns	
SWDIO output valid time after SWDCLK rising edge	t_5	CC	–	–	17	ns	$C_L = 50$ pF
			–	–	13	ns	$C_L = 30$ pF
SWDIO output hold time from SWDCLK rising edge	t_6	CC	3	–	–	ns	

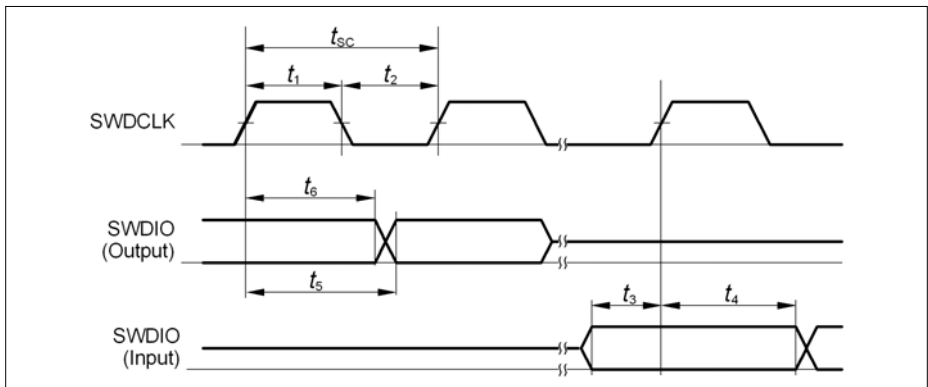

Figure 25 SWD Timing

3.3.8 Peripheral Timing

3.3.8.1 Synchronous Serial Interface (USIC SSC) Timing

The following parameters are applicable for a USIC channel operated in SSC mode.

Note: These parameters are not subject to production test, but verified by design and/or characterization.

Table 43 USIC SSC Master Mode Timing

Parameter	Symbol	Values			Unit	Note / Test Condition
		Min.	Typ.	Max.		
SCLKOUT master clock period	t_{CLK} CC	33.3	–	–	ns	
Slave select output SELO active to first SCLKOUT transmit edge	t_1 CC	$t_{PB} - 6.5^{1)}$	–	–	ns	
Slave select output SELO inactive after last SCLKOUT receive edge	t_2 CC	$t_{PB} - 8.5^{1)}$	–	–	ns	
Data output DOUT[3:0] valid time	t_3 CC	-6	–	8	ns	
Receive data input DX0/DX[5:3] setup time to SCLKOUT receive edge	t_4 SR	23	–	–	ns	
Data input DX0/DX[5:3] hold time from SCLKOUT receive edge	t_5 SR	1	–	–	ns	

1) $t_{PB} = 1 / f_{PB}$

Table 44 USIC SSC Slave Mode Timing

Parameter	Symbol	Values			Unit	Note / Test Condition
		Min.	Typ.	Max.		
DX1 slave clock period	t_{CLK} SR	66.6	–	–	ns	
Select input DX2 setup to first clock input DX1 transmit edge ¹⁾	t_{10} SR	3	–	–	ns	
Select input DX2 hold after last clock input DX1 receive edge ¹⁾	t_{11} SR	4	–	–	ns	
Receive data input DX0/DX[5:3] setup time to shift clock receive edge ¹⁾	t_{12} SR	6	–	–	ns	
Data input DX0/DX[5:3] hold time from clock input DX1 receive edge ¹⁾	t_{13} SR	4	–	–	ns	
Data output DOUT[3:0] valid time	t_{14} CC	0	–	24	ns	

1) This input timing is valid for asynchronous input signal handling of slave select input, shift clock input, and receive data input (bits DXnCR.DSEN = 0).

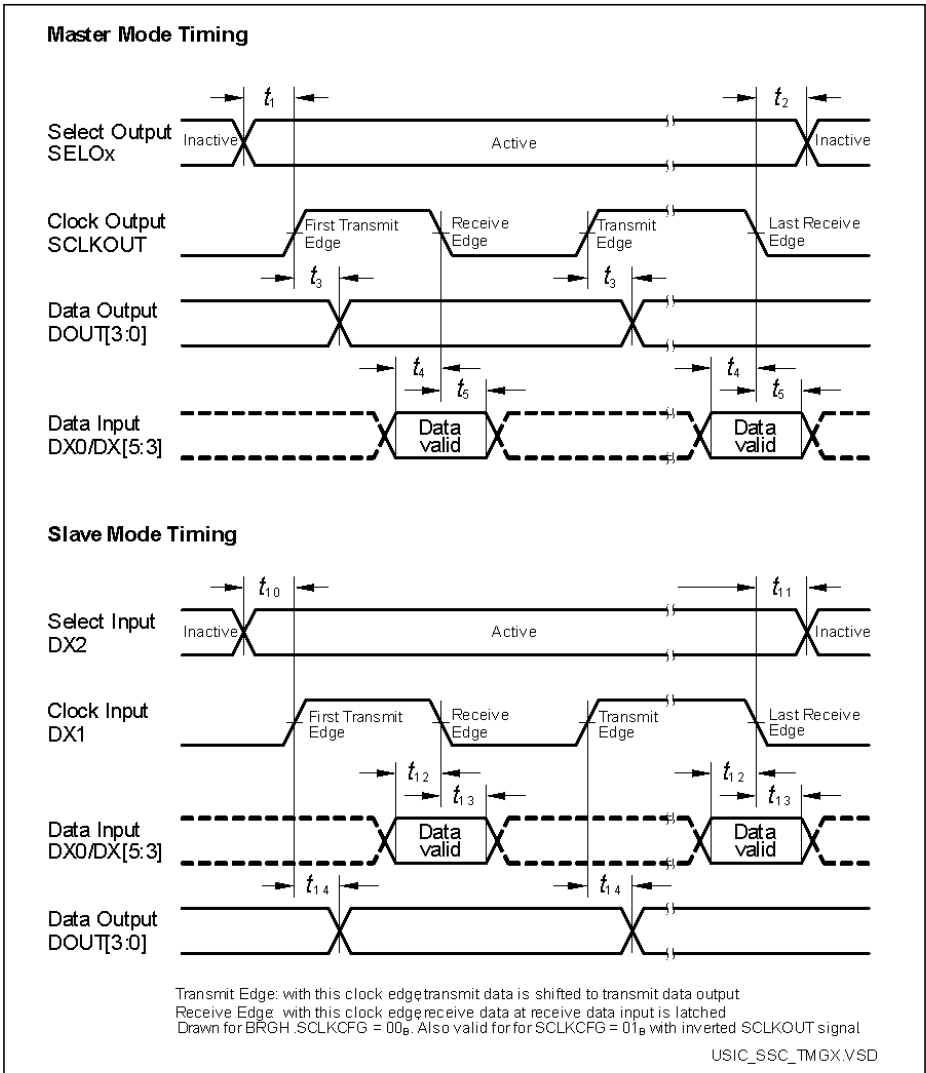

Figure 26 USIC - SSC Master/Slave Mode Timing

Note: This timing diagram shows a standard configuration, for which the slave select signal is low-active, and the serial clock signal is not shifted and not inverted.

3.3.8.2 Inter-IC (IIC) Interface Timing

The following parameters are applicable for a USIC channel operated in IIC mode.

Note: These parameters are not subject to production test, but verified by design and/or characterization.

Table 45 USIC IIC Standard Mode Timing¹⁾

Parameter	Symbol	Values			Unit	Note / Test Condition
		Min.	Typ.	Max.		
Fall time of both SDA and SCL	t_1 CC/SR	-	-	300	ns	
Rise time of both SDA and SCL	t_2 CC/SR	-	-	1000	ns	
Data hold time	t_3 CC/SR	0	-	-	μs	
Data set-up time	t_4 CC/SR	250	-	-	ns	
LOW period of SCL clock	t_5 CC/SR	4.7	-	-	μs	
HIGH period of SCL clock	t_6 CC/SR	4.0	-	-	μs	
Hold time for (repeated) START condition	t_7 CC/SR	4.0	-	-	μs	
Set-up time for repeated START condition	t_8 CC/SR	4.7	-	-	μs	
Set-up time for STOP condition	t_9 CC/SR	4.0	-	-	μs	
Bus free time between a STOP and START condition	t_{10} CC/SR	4.7	-	-	μs	
Capacitive load for each bus line	C_b SR	-	-	400	pF	

1) Due to the wired-AND configuration of an IIC bus system, the port drivers of the SCL and SDA signal lines need to operate in open-drain mode. The high level on these lines must be held by an external pull-up device, approximately 10 kOhm for operation at 100 kbit/s, approximately 2 kOhm for operation at 400 kbit/s.

Table 46 USIC IIC Fast Mode Timing¹⁾

Parameter	Symbol	Values			Unit	Note / Test Condition
		Min.	Typ.	Max.		
Fall time of both SDA and SCL	t_1 CC/SR	20 + 0.1 * C _b 2)	-	300	ns	
Rise time of both SDA and SCL	t_2 CC/SR	20 + 0.1 * C _b 2)	-	300	ns	
Data hold time	t_3 CC/SR	0	-	-	μs	
Data set-up time	t_4 CC/SR	100	-	-	ns	
LOW period of SCL clock	t_5 CC/SR	1.3	-	-	μs	
HIGH period of SCL clock	t_6 CC/SR	0.6	-	-	μs	
Hold time for (repeated) START condition	t_7 CC/SR	0.6	-	-	μs	
Set-up time for repeated START condition	t_8 CC/SR	0.6	-	-	μs	
Set-up time for STOP condition	t_9 CC/SR	0.6	-	-	μs	
Bus free time between a STOP and START condition	t_{10} CC/SR	1.3	-	-	μs	
Capacitive load for each bus line	C _b SR	-	-	400	pF	

1) Due to the wired-AND configuration of an IIC bus system, the port drivers of the SCL and SDA signal lines need to operate in open-drain mode. The high level on these lines must be held by an external pull-up device, approximately 10 kOhm for operation at 100 kbit/s, approximately 2 kOhm for operation at 400 kbit/s.

2) C_b refers to the total capacitance of one bus line in pF.

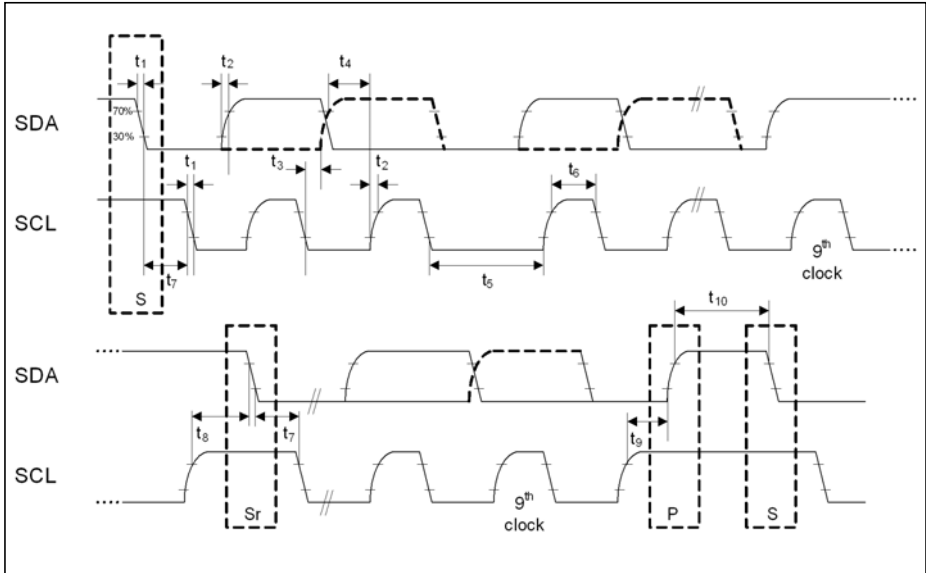

Figure 27 USIC IIC Stand and Fast Mode Timing

3.3.8.3 Inter-IC Sound (IIS) Interface Timing

The following parameters are applicable for a USIC channel operated in IIS mode.

Note: These parameters are not subject to production test, but verified by design and/or characterization.

Table 47 USIC IIS Master Transmitter Timing

Parameter	Symbol	Values			Unit	Note / Test Condition
		Min.	Typ.	Max.		
Clock period	t_1 CC	33.3	–	–	ns	
Clock high time	t_2 CC	0.35 x t_{1min}	–	–	ns	
Clock low time	t_3 CC	0.35 x t_{1min}	–	–	ns	
Hold time	t_4 CC	0	–	–	ns	
Clock rise time	t_5 CC	–	–	0.15 x t_{1min}	ns	

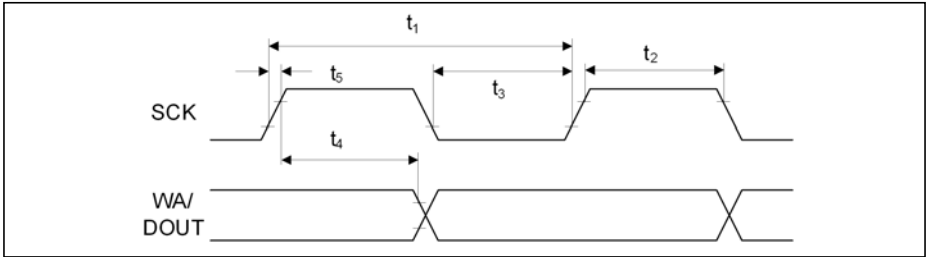

Figure 28 USIC IIS Master Transmitter Timing

Table 48 USIC IIS Slave Receiver Timing

Parameter	Symbol	Values			Unit	Note / Test Condition
		Min.	Typ.	Max.		
Clock period	t_6 SR	66.6	–	–	ns	
Clock high time	t_7 SR	0.35 x t_{6min}	–	–	ns	
Clock low time	t_8 SR	0.35 x t_{6min}	–	–	ns	
Set-up time	t_9 SR	0.2 x t_{6min}	–	–	ns	
Hold time	t_{10} SR	0	–	–	ns	

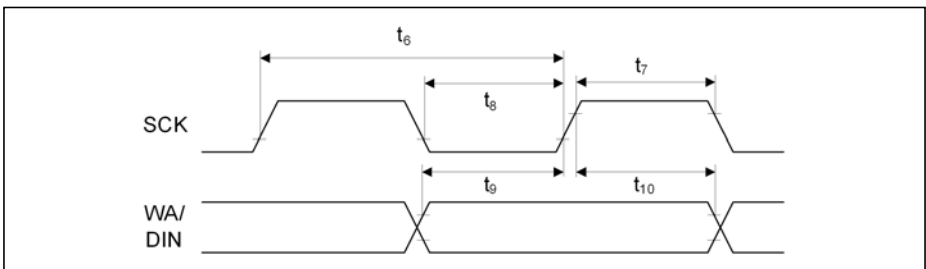

Figure 29 USIC IIS Slave Receiver Timing

3.3.8.4 SDMMC Interface Timing

Note: These parameters are not subject to production test, but verified by design and/or characterization.

Note: Operating Conditions apply, total external capacitive load $C_L = 40$ pF.

AC Timing Specifications (Full-Speed Mode)

Table 49 SDMMC Timing for Full-Speed Mode

Parameter	Symbol	Values	Unit		Note/ Test Condition
			Min.	Max.	
Clock frequency in full speed transfer mode ($1/t_{pp}$)	f_{pp} CC	0	24	MHz	
Clock cycle in full speed transfer mode	t_{pp} CC	40	–	ns	
Clock low time	t_{WL} CC	10	–	ns	
Clock high time	t_{WH} CC	10	–	ns	
Clock rise time	t_{TLH} CC	–	10	ns	
Clock fall time	t_{THL} CC	–	10	ns	
Inputs setup to clock rising edge	t_{ISU_F} SR	2	–	ns	
Inputs hold after clock rising edge	t_{IH_F} SR	2	–	ns	
Outputs valid time in full speed mode	t_{ODLY_F} CC	–	10	ns	
Outputs hold time in full speed mode	t_{OH_F} CC	0	–	ns	

Table 50 SD Card Bus Timing for Full-Speed Mode¹⁾

Parameter	Symbol	Values		Unit	Note/ Test Condition
		Min.	Max.		
SD card input setup time	t_{ISU}	5	–	ns	
SD card input hold time	t_{IH}	5	–	ns	
SD card output valid time	t_{ODLY}	–	14	ns	
SD card output hold time	t_{OH}	0	–	ns	

1) Reference card timing values for calculation examples. Not subject to production test and not characterized.

Full-Speed Output Path (Write)

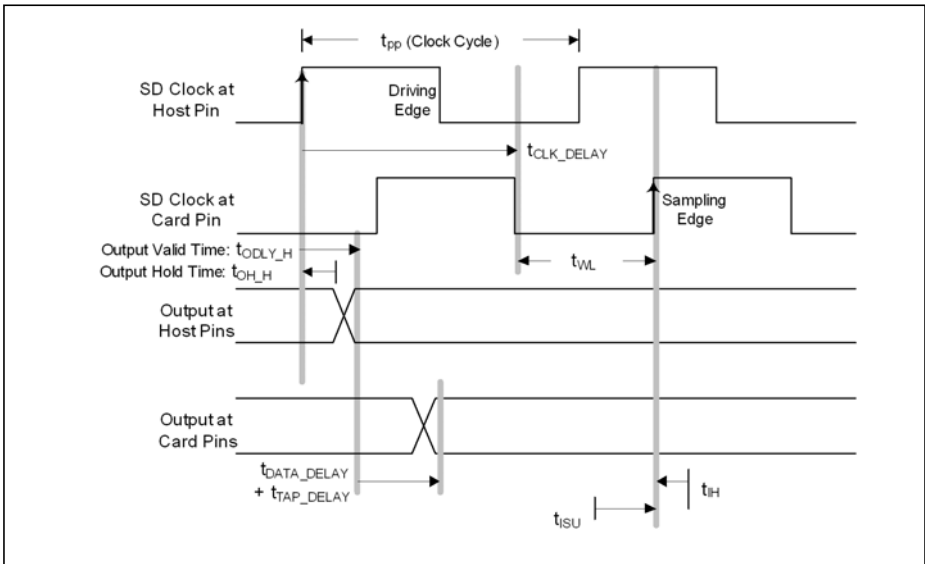

Figure 30 Full-Speed Output Path

Full-Speed Write Meeting Setup (Maximum Delay)

The following equations show how to calculate the allowed skew range between the SD_CLK and SD_DAT/CMD signals on the PCB.

No clock delay:

$$t_{ODLY_F} + t_{DATA_DELAY} + t_{TAP_DELAY} + t_{ISU} < t_{WL} \tag{1}$$

With clock delay:

$$t_{ODLY_F} + t_{DATA_DELAY} + t_{TAP_DELAY} + t_{ISU} < t_{WL} + t_{CLK_DELAY} \tag{2}$$

$$t_{DATA_DELAY} + t_{TAP_DELAY} + t_{WL} < t_{PP} + t_{CLK_DELAY} - t_{ISU} - t_{ODLY_F} \tag{3}$$

$$t_{DATA_DELAY} + t_{TAP_DELAY} + 20 < 40 + t_{CLK_DELAY} - 5 - 10$$

$$t_{DATA_DELAY} < 5 + t_{CLK_DELAY} - t_{TAP_DELAY}$$

The data can be delayed versus clock up to 5 ns in ideal case of $t_{WL} = 20$ ns.

Full-Speed Write Meeting Hold (Minimum Delay)

The following equations show how to calculate the allowed skew range between the SD_CLK and SD_DAT/CMD signals on the PCB.

$$t_{CLK_DELAY} < t_{WL} + t_{OH_F} + t_{DATA_DELAY} + t_{TAP_DELAY} - t_{IH} \tag{4}$$

$$t_{CLK_DELAY} < 20 + t_{DATA_DELAY} + t_{TAP_DELAY} - 5$$

$$t_{DATA_DELAY} < 15 + t_{CLK_DELAY} + t_{TAP_DELAY}$$

The clock can be delayed versus data up to 18.2 ns (external delay line) in ideal case of $t_{WL} = 20$ ns, with maximum $t_{TAP_DELAY} = 3.2$ ns programmed.

Full-Speed Input Path (Read)

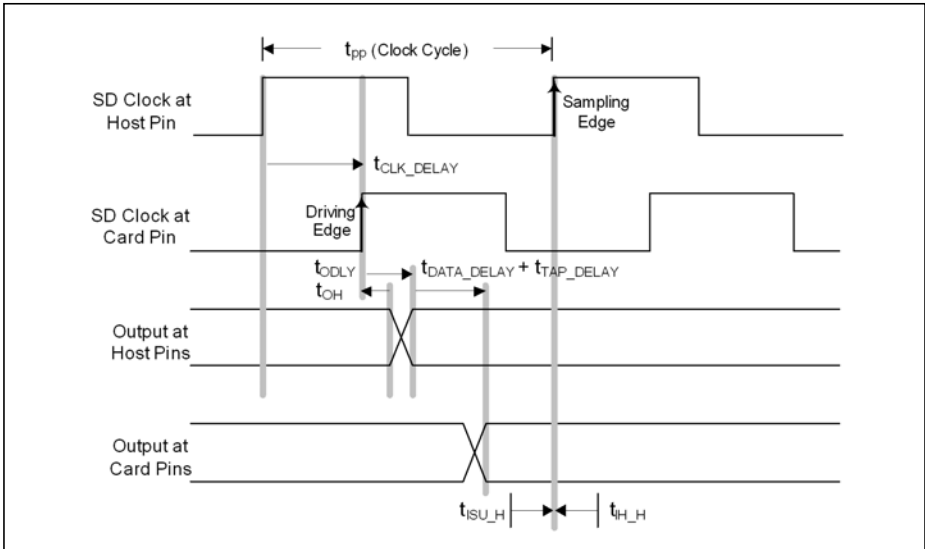

Figure 31 Full-Speed Input Path

Full-Speed Read Meeting Setup (Maximum Delay)

The following equations show how to calculate the allowed combined propagation delay range of the SD_CLK and SD_DAT/CMD signals on the PCB.

(5)

$$t_{CLK_DELAY} + t_{DATA_DELAY} + t_{TAP_DELAY} + t_{ODLY} + t_{ISU_F} < 0.5 \times t_{pp}$$

$$t_{CLK_DELAY} + t_{DATA_DELAY} < 0.5 \times t_{pp} - t_{ODLY} - t_{ISU_F} - t_{TAP_DELAY}$$

$$t_{CLK_DELAY} + t_{DATA_DELAY} < 20 - 14 - 2 - t_{TAP_DELAY}$$

$$t_{CLK_DELAY} + t_{DATA_DELAY} < 4 - t_{TAP_DELAY}$$

The data + clock delay can be up to 4 ns for a 40 ns clock cycle.

Electrical Parameters

Full-Speed Read Meeting Hold (Minimum Delay)

The following equations show how to calculate the allowed combined propagation delay range of the SD_CLK and SD_DAT/CMD signals on the PCB.

(6)

$$t_{\text{CLK_DELAY}} + t_{\text{OH}} + t_{\text{DATA_DELAY}} + t_{\text{TAP_DELAY}} > t_{\text{IH_F}}$$

$$t_{\text{CLK_DELAY}} + t_{\text{DATA_DELAY}} > t_{\text{IH_F}} - t_{\text{OH}} - t_{\text{TAP_DELAY}}$$

$$t_{\text{CLK_DELAY}} + t_{\text{DATA_DELAY}} > 2 - t_{\text{TAP_DELAY}}$$

The data + clock delay must be greater than 2 ns if $t_{\text{TAP_DELAY}}$ is not used.

If the $t_{\text{TAP_DELAY}}$ is programmed to at least 2 ns, the data + clock delay must be greater than 0 ns (or less). This is always fulfilled.

AC Timing Specifications (High-Speed Mode)

Table 51 SDMMC Timing for High-Speed Mode

Parameter	Symbol	Values	Unit		Note/ Test Condition
			Min.	Max.	
Clock frequency in high speed transfer mode ($1/t_{\text{pp}}$)	f_{pp} CC	0	48	MHz	
Clock cycle in high speed transfer mode	t_{pp} CC	20	–	ns	
Clock low time	t_{WL} CC	7	–	ns	
Clock high time	t_{WH} CC	7	–	ns	
Clock rise time	t_{TLH} CC	–	3	ns	
Clock fall time	t_{THL} CC	–	3	ns	
Inputs setup to clock rising edge	$t_{\text{ISU_H}}$ SR	2	–	ns	
Inputs hold after clock rising edge	$t_{\text{IH_H}}$ SR	2	–	ns	
Outputs valid time in high speed mode	$t_{\text{ODLY_H}}$ CC	–	14	ns	
Outputs hold time in high speed mode	$t_{\text{OH_H}}$ CC	2	–	ns	

Table 52 SD Card Bus Timing for High-Speed Mode¹⁾

Parameter	Symbol	Values		Unit	Note/ Test Condition
		Min.	Max.		
SD card input setup time	t_{ISU}	6	–	ns	
SD card input hold time	t_{IH}	2	–	ns	
SD card output valid time	t_{ODLY}	–	14	ns	
SD card output hold time	t_{OH}	2.5	–	ns	

1) Reference card timing values for calculation examples. Not subject to production test and not characterized.

High-Speed Output Path (Write)

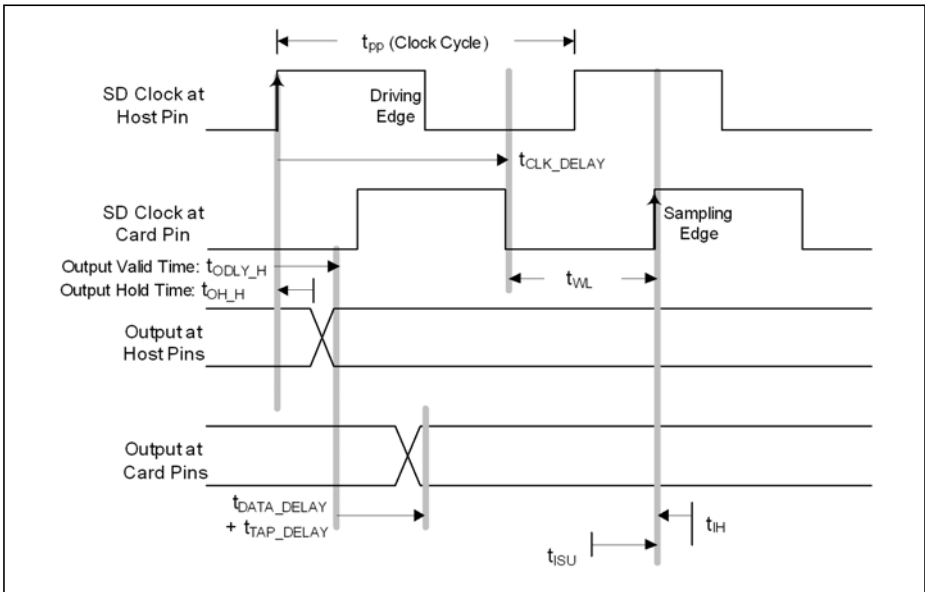

Figure 32 High-Speed Output Path

High-Speed Write Meeting Setup (Maximum Delay)

The following equations show how to calculate the allowed skew range between the SD_CLK and SD_DAT/CMD signals on the PCB.

No clock delay:

$$t_{ODLY_H} + t_{DATA_DELAY} + t_{TAP_DELAY} + t_{ISU} < t_{WL} \quad (7)$$

With clock delay:

$$t_{ODLY_H} + t_{DATA_DELAY} + t_{TAP_DELAY} + t_{ISU} < t_{WL} + t_{CLK_DELAY} \quad (8)$$

$$t_{DATA_DELAY} + t_{TAP_DELAY} - t_{CLK_DELAY} < t_{WL} - t_{ISU} - t_{ODLY_H} \quad (9)$$

$$t_{DATA_DELAY} - t_{CLK_DELAY} < t_{WL} - t_{ISU} - t_{ODLY_H} - t_{TAP_DELAY}$$

$$t_{DATA_DELAY} - t_{CLK_DELAY} < 10 - 6 - 14 - t_{TAP_DELAY}$$

$$t_{DATA_DELAY} - t_{CLK_DELAY} < -10 - t_{TAP_DELAY}$$

The data delay is less than the clock delay by at least 10 ns in the ideal case where $t_{WL} = 10$ ns.

High-Speed Write Meeting Hold (Minimum Delay)

The following equations show how to calculate the allowed skew range between the SD_CLK and SD_DAT/CMD signals on the PCB.

$$t_{CLK_DELAY} < t_{WL} + t_{OH_H} + t_{DATA_DELAY} + t_{TAP_DELAY} - t_{IH} \quad (10)$$

$$t_{CLK_DELAY} - t_{DATA_DELAY} < t_{WL} + t_{OH_H} + t_{TAP_DELAY} - t_{IH}$$

$$t_{CLK_DELAY} - t_{DATA_DELAY} < 10 + 2 + t_{TAP_DELAY} - 2$$

$$t_{CLK_DELAY} - t_{DATA_DELAY} < 10 + t_{TAP_DELAY}$$

Electrical Parameters

The clock can be delayed versus data up to 13.2 ns (external delay line) in ideal case of $t_{WL} = 10$ ns, with maximum $t_{TAP_DELAY} = 3.2$ ns programmed.

High-Speed Input Path (Read)

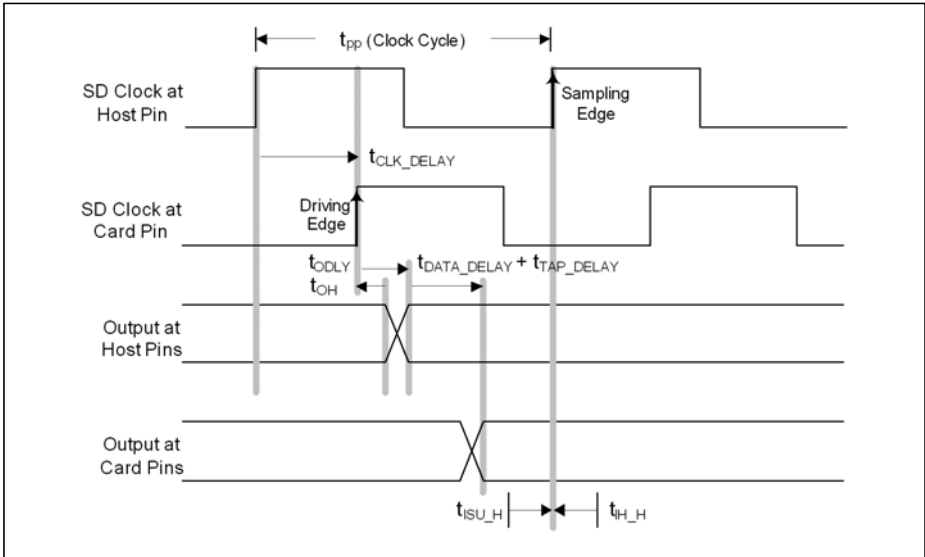

Figure 33 High-Speed Input Path

High-Speed Read Meeting Setup (Maximum Delay)

The following equations show how to calculate the allowed combined propagation delay range of the SD_CLK and SD_DAT/CMD signals on the PCB.

(11)

$$t_{CLK_DELAY} + t_{DATA_DELAY} + t_{TAP_DELAY} + t_{ODLY} + t_{ISU_H} < t_{pp}$$

$$t_{CLK_DELAY} + t_{DATA_DELAY} < t_{pp} - t_{ODLY} - t_{ISU_H} - t_{TAP_DELAY}$$

$$t_{CLK_DELAY} + t_{DATA_DELAY} < 20 - 14 - 2 - t_{TAP_DELAY}$$

$$t_{CLK_DELAY} + t_{DATA_DELAY} < 4 - t_{TAP_DELAY}$$

The data + clock delay can be up to 4 ns for a 20 ns clock cycle.

Electrical Parameters

High-Speed Read Meeting Hold (Minimum Delay)

The following equations show how to calculate the allowed combined propagation delay range of the SD_CLK and SD_DAT/CMD signals on the PCB.

(12)

$$t_{\text{CLK_DELAY}} + t_{\text{OH}} + t_{\text{DATA_DELAY}} + t_{\text{TAP_DELAY}} > t_{\text{IH_H}}$$

$$t_{\text{CLK_DELAY}} + t_{\text{DATA_DELAY}} > t_{\text{IH_H}} - t_{\text{OH}} - t_{\text{TAP_DELAY}}$$

$$t_{\text{CLK_DELAY}} + t_{\text{DATA_DELAY}} > 2 - 2.5 - t_{\text{TAP_DELAY}}$$

$$t_{\text{CLK_DELAY}} + t_{\text{DATA_DELAY}} > -0.5 - t_{\text{TAP_DELAY}}$$

The data + clock delay must be greater than -0.5 ns for a 20 ns clock cycle. This is always fulfilled.

3.3.9 USB Interface Characteristics

The Universal Serial Bus (USB) Interface is compliant to the USB Rev. 2.0 Specification and the OTG Specification Rev. 1.3. High-Speed Mode is not supported.

Note: These parameters are not subject to production test, but verified by design and/or characterization.

Table 53 USB Timing Parameters (operating conditions apply)

Parameter	Symbol		Values			Unit	Note / Test Condition
			Min.	Typ.	Max.		
Rise time	t_R	CC	4	–	20	ns	$C_L = 50 \text{ pF}$
Fall time	t_F	CC	4	–	20	ns	$C_L = 50 \text{ pF}$
Rise/Fall time matching	t_R/t_F	CC	90	–	111.11	%	$C_L = 50 \text{ pF}$
Crossover voltage	V_{CRS}	CC	1.3	–	2.0	V	$C_L = 50 \text{ pF}$

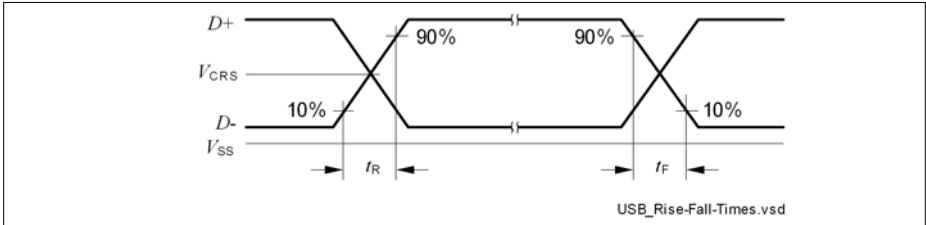

Figure 34 USB Signal Timing

3.3.10 Ethernet Interface (ETH) Characteristics

For proper operation of the Ethernet Interface it is required that $f_{SYS} \geq 100$ MHz.

Note: These parameters are not subject to production test, but verified by design and/or characterization.

3.3.10.1 ETH Measurement Reference Points

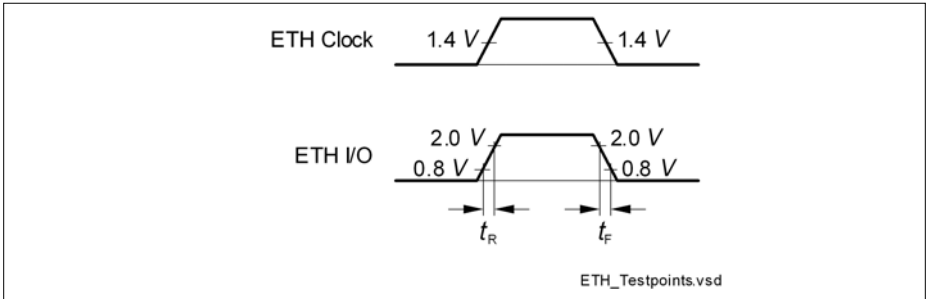

Figure 35 ETH Measurement Reference Points

3.3.10.2 ETH Management Signal Parameters (ETH_MDC, ETH_MDIO)

Table 54 ETH Management Signal Timing Parameters

Parameter	Symbol		Values			Unit	Note / Test Condition
			Min.	Typ.	Max.		
ETH_MDC period	t_1	CC	400	–	–	ns	$C_L = 25 \text{ pF}$
ETH_MDC high time	t_2	CC	160	–	–	ns	
ETH_MDC low time	t_3	CC	160	–	–	ns	
ETH_MDIO setup time (output)	t_4	CC	10	–	–	ns	
ETH_MDIO hold time (output)	t_5	CC	10	–	–	ns	
ETH_MDIO data valid (input)	t_6	SR	0	–	300	ns	

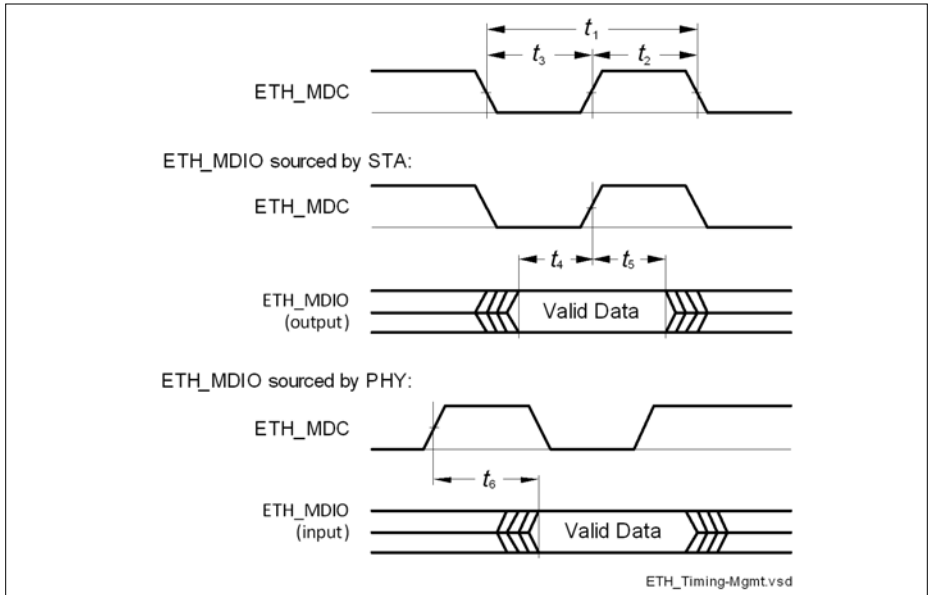

Figure 36 ETH Management Signal Timing

3.3.10.3 ETH RMII Parameters

In the following, the parameters of the RMII (Reduced Media Independent Interface) are described.

Table 55 ETH RMII Signal Timing Parameters

Parameter	Symbol		Values			Unit	Note / Test Condition
			Min.	Typ.	Max.		
ETH_RMII_REF_CL clock period	t_{13}	SR	20	–	–	ns	$C_L = 25 \text{ pF}; 50 \text{ ppm}$
ETH_RMII_REF_CL clock high time	t_{14}	SR	7	–	13	ns	$C_L = 25 \text{ pF}$
ETH_RMII_REF_CL clock low time	t_{15}	SR	7	–	13	ns	
ETH_RMII_RXD[1:0], ETH_RMII_CRD setup time	t_{16}	SR	4	–	–	ns	
ETH_RMII_RXD[1:0], ETH_RMII_CRD hold time	t_{17}	SR	2	–	–	ns	
ETH_RMII_TXD[1:0], ETH_RMII_TXEN data valid	t_{18}	CC	4	–	15	ns	

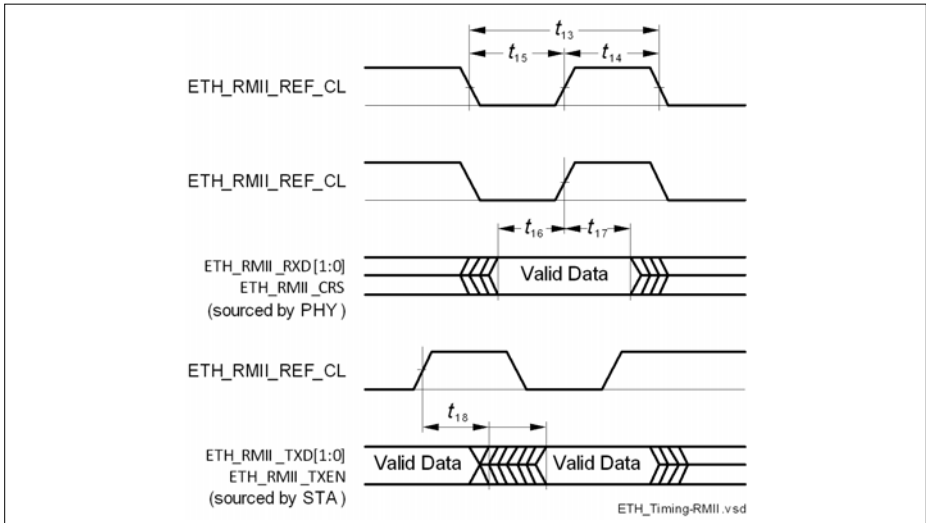

Figure 37 ETH RMII Signal Timing

3.3.11 EtherCAT (ECAT) Characteristics

3.3.11.1 ECAT Measurement Reference Points

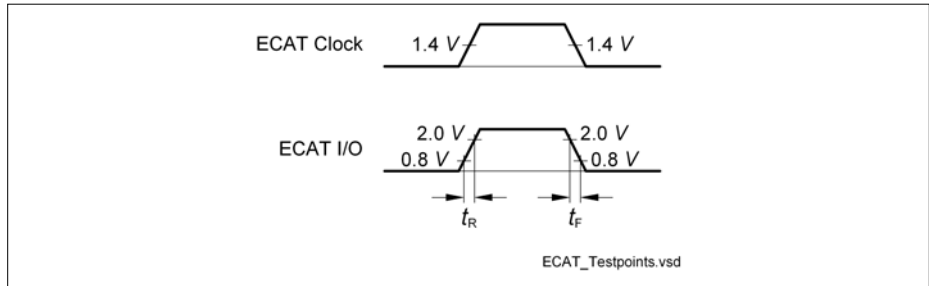

Figure 38 Measurement Reference Points

3.3.11.2 ETH Management Signal Parameters (MCLK, MDIO)

Table 56 ECAT Management Signal Timing Parameters

Parameter	Symbol	Values			Unit	Note / Test Condition
		Min.	Typ.	Max.		
ECAT_MCLK period	t_{MCLK} CC	–	400	–	ns	IEEE802.3 requirement (2.5 MHz) $C_L = 25$ pF
ECAT_MCLK high time	t_{MCLK_h} CC	160	–	–	ns	
ECAT_MCLK low time	t_{MCLK_l} CC	160	–	–	ns	
ECAT_MDIO setup time (output)	t_{D_setup} CC	10	–	–	ns	
ECAT_MDIO hold time (output)	t_{D_hold} CC	10	–	–	ns	
ECAT_MDIO data valid (input)	t_{D_valid} SR	0	–	300	ns	

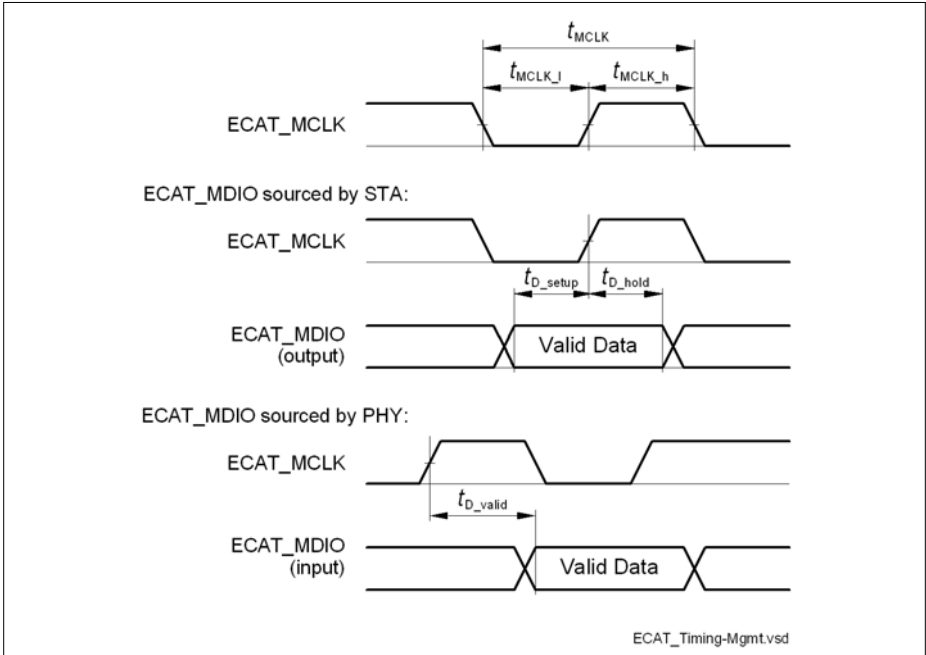

Figure 39 ECAT Management Signal Timing

3.3.11.3 MII Timing TX Characteristics

Table 57 ETH MII TX Signal Timing Parameters

Parameter	Symbol	Values			Unit	Note / Test Condition
		Min.	Typ.	Max.		
PHY_CLK25, TX_CLK period	t_{TX_CLK} SR	–	40	–	ns	
Delay between PHY clock source PHY_CLK25 and TX_CLK output of the PHY	t_{PHY_delay} SR	–	–	–	ns	PHY dependent

Electrical Parameters

Table 57 ETH MII TX Signal Timing Parameters (cont'd)

Parameter	Symbol	Values			Unit	Note / Test Condition
		Min.	Typ.	Max.		
PHY setup requirement: TXEN/TXD[3:0] with respect to TX_CLK	t_{TX_setup} SR	15	–	0	ns	PHY dependent IEEE802.3 limit is 15 ns
PHY hold requirement: TXEN/TXD[3:0] with respect to TX_CLK	t_{TX_hold} CC	0	–	25	ns	PHY dependent IEEE802.3 limit is 0 ns

Note: ECAT0_CONPx.TX_SHIFT can be adjusted by displaying TX_CLK of a PHY and TXEN/TXD[3:0] on an oscilloscope. TXEN/TXD[3:0] is allowed to change between 0 ns and 25 ns after a rising edge of TX_CLK (according to IEEE802.3 – check your PHY's documentation). Configure TX_SHIFT so that TXEN/TXD[3:0] change near the middle of this range. It is sufficient to check just one of the TXEN/TXD[3:0] signals, because they are nearly generated at the same time.

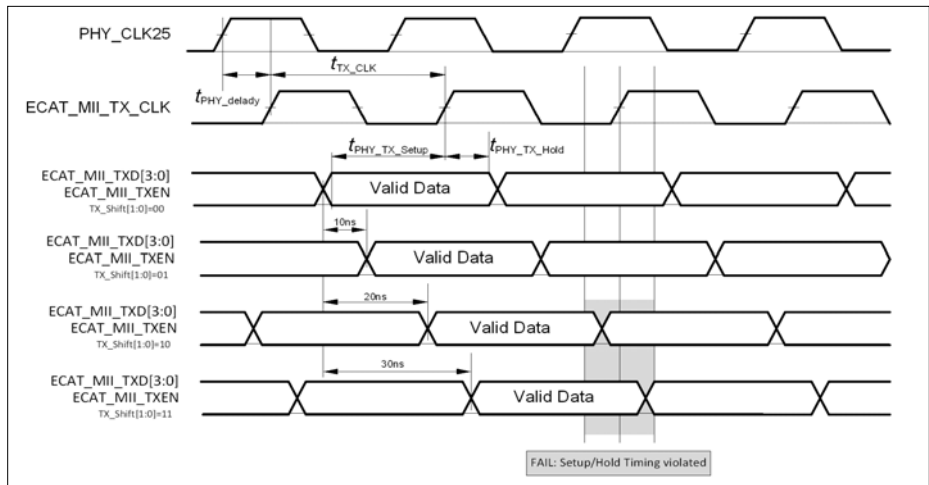

Figure 40 MII TX Characteristics

3.3.11.4 MII Timing RX Characteristics

Table 58 ETH MII RX Signal Timing Parameters

Parameter	Symbol	Values			Unit	Note / Test Condition
		Min.	Typ.	Max.		
RX_CLK period	t_{RX_CLK} SR	–	40	–	ns	$C_L = 25\text{ pF}$, IEEE802.3 requirement
RX_DV/RX_DV/RXD[3:0] valid before rising edge of RX_CLK	t_{RX_setup} SR	10	–	–	ns	
RX_DV/RX_DV/RXD[3:0] valid after rising edge of RX_CLK	t_{RX_hold} SR	10	–	–	ns	

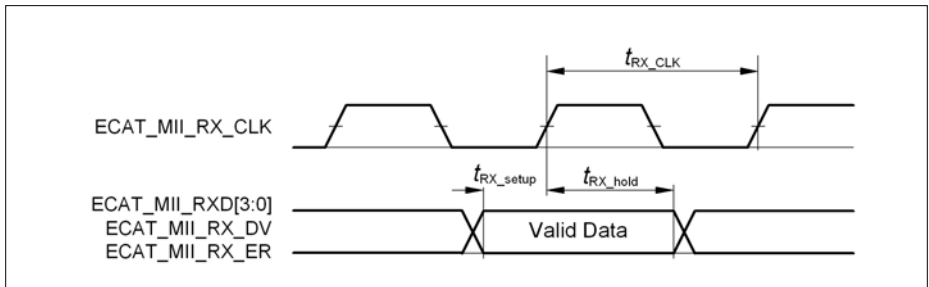

Figure 41 MII RX characteristics

3.3.11.5 Sync/Latch Timings

Table 59 Sync/Latch Timings

Parameter	Symbol	Values			Unit	Note / Test Condition
		Min.	Typ.	Max.		
SYNC0/1	$t_{DC_SYNC_Jitter_SR}$	–	–	11 + m ¹⁾	ns	
LATCH0/1	$t_{DC_LATCH_SR}$	12 + n ²⁾	–	–	ns	

- 1) additional delay form logic and pad, number is added after characterization
- 2) additional shaping delay, number is added after characterization

Note: SYNC0/1 pulse length are initially loaded by EEPROM content ADR 0x0002. The actual used value can be read back from Register DC_PULSE_LEN.

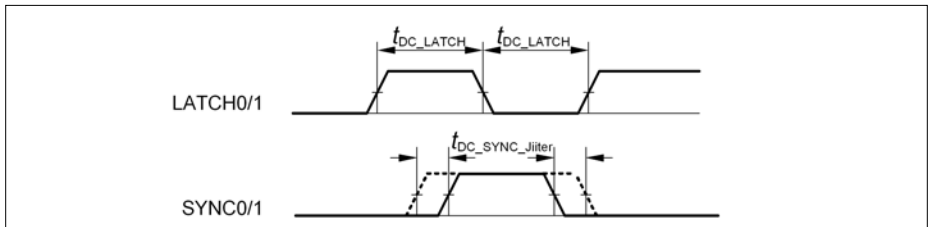

Figure 42 Sync/Latch Timings

4 Package and Reliability

The XMC4300 is a member of the XMC4000 Family of microcontrollers. It is also compatible to a certain extent with members of similar families or subfamilies.

Each package is optimized for the device it houses. Therefore, there may be slight differences between packages of the same pin-count but for different device types. In particular, the size of the Exposed Die Pad may vary.

If different device types are considered or planned for an application, it must be ensured that the board layout fits all packages under consideration.

4.1 Package Parameters

Table 60 provides the thermal characteristics of the packages used in XMC4300.

Table 60 Thermal Characteristics of the Packages

Parameter	Symbol	Limit Values		Unit	Package Types
		Min.	Max.		
Exposed Die Pad dimensions including U-Groove	$E_x \times E_y$ CC	-	7.0 × 7.0	mm	PG-LQFP-100-25
Exposed Die Pad dimensions excluding U-Groove	$A_x \times A_y$ CC	-	6.2 × 6.2	mm	PG-LQFP-100-25
Exposed Die Pad dimensions	-	-	7.0 × 7.0	mm	PG-LQFP-100-29
Thermal resistance Junction-Ambient $T_J \leq 150\text{ °C}$	$R_{\Theta JA}$ CC	-	22.5	K/W	PG-LQFP-100-25 ¹⁾ PG-LQFP-100-29 ¹⁾

1) Device mounted on a 4-layer JEDEC board (JESD 51-7) with thermal vias; exposed pad soldered.

Note: For electrical reasons, it is required to connect the exposed pad to the board ground V_{SS} , independent of EMC and thermal requirements.

4.1.1 Thermal Considerations

When operating the XMC4300 in a system, the total heat generated in the chip must be dissipated to the ambient environment to prevent overheating and the resulting thermal damage.

The maximum heat that can be dissipated depends on the package and its integration into the target board. The “Thermal resistance $R_{\Theta JA}$ ” quantifies these parameters. The power dissipation must be limited so that the average junction temperature does not exceed 150 °C.

The difference between junction temperature and ambient temperature is determined by $\Delta T = (P_{INT} + P_{IOSTAT} + P_{IODYN}) \times R_{\Theta JA}$

The internal power consumption is defined as

$$P_{INT} = V_{DDP} \times I_{DDP} \text{ (switching current and leakage current).}$$

The static external power consumption caused by the output drivers is defined as

$$P_{IOSTAT} = \Sigma((V_{DDP} - V_{OH}) \times I_{OH}) + \Sigma(V_{OL} \times I_{OL})$$

The dynamic external power consumption caused by the output drivers (P_{IODYN}) depends on the capacitive load connected to the respective pins and their switching frequencies.

If the total power dissipation for a given system configuration exceeds the defined limit, countermeasures must be taken to ensure proper system operation:

- Reduce V_{DDP} , if possible in the system
- Reduce the system frequency
- Reduce the number of output pins
- Reduce the load on active output drivers

4.2 Package Outlines

The exposed die pad dimensions are listed in **Table 60**.

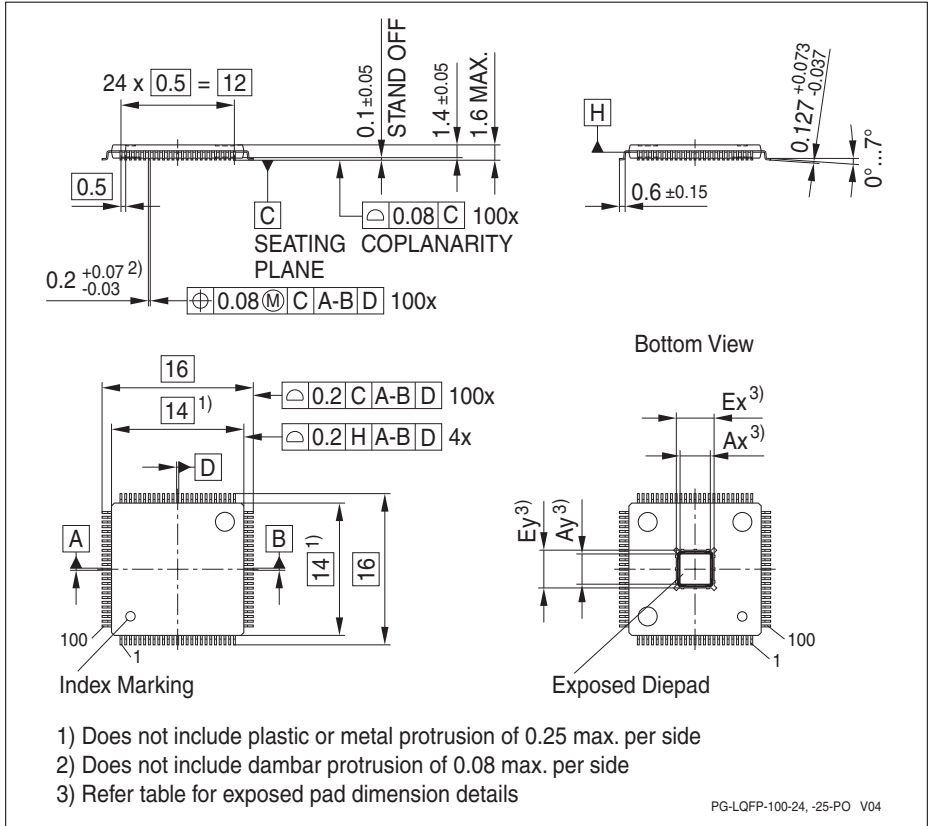

Figure 43 PG-LQFP-100-25 (Plastic Green Low Profile Quad Flat Package)

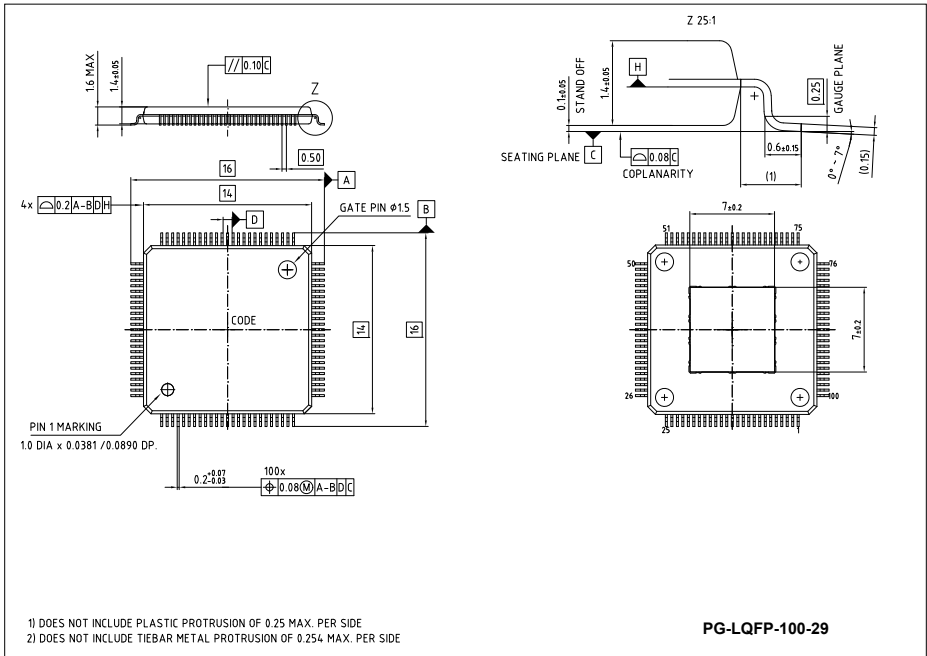

Figure 44 PG-LQFP-100-29 (Plastic Green Low Profile Quad Flat Package)

All dimensions in mm.

You can find complete information about Infineon packages, packing and marking in our Infineon Internet Page “Packages”: <http://www.infineon.com/packages>

5 Quality Declarations

The qualification of the XMC4300 is executed according to the JEDEC standard JESD471.

Note: For automotive applications refer to the Infineon automotive microcontrollers.

Table 61 Quality Parameters

Parameter	Symbol	Values			Unit	Note / Test Condition
		Min.	Typ.	Max.		
Operation lifetime	t_{OP} CC	20	–	–	a	$T_J \leq 109^\circ\text{C}$, device permanent on
ESD susceptibility according to Human Body Model (HBM)	V_{HBM} SR	–	–	3 000	V	EIA/JESD22-A114-B
ESD susceptibility according to Charged Device Model (CDM)	V_{CDM} SR	–	–	1 000	V	Conforming to JESD22-C101-C
Moisture sensitivity level	MSL CC	–	–	3	–	JEDEC J-STD-020D
Soldering temperature	T_{SDR} SR	–	–	260	$^\circ\text{C}$	Profile according to JEDEC J-STD-020D

www.infineon.com

Published by Infineon Technologies AG

Looking for pricing, stock, or lifecycle information?

Click below to explore more details on WIN SOURCE:

- ➔ [View XMC4300F100F256AAXQMA1 on WIN SOURCE](#)
- ➔ [Infineon Technologies Information](#)

Optimize Your Supply Chain with WIN SOURCE Solutions

- ✓ Global Sourcing Solution
- ✓ Obsolete Management
- ✓ Cost Control Management
- ✓ Shortage Management
- ✓ Alternative Solution
- ✓ Excess Inventory Management