



**THE DATASHEET OF  
MAMF-011069-TR1000**



## Integrated Dual Switch - LNA Module 1.8 - 3.9 GHz

Rev. V1

### Features

- Dual Channel Architecture
- Two Low Noise Amplifiers
- Two High Power Switches
- 20 W CW PIN Switch Power Handling
- Gain (Rx Mode):
  - 33 dB @ 2.6 GHz
  - 34 dB @ 3.5 GHz
- Noise Figure (Rx Mode):
  - 1.2 dB @ 2.6 GHz
  - 1.5 dB @ 3.5 GHz
- 0.5 dB Insertion Loss (Tx Mode)
- Lead-Free 5 mm 32-Lead QFN Package
- Integrated ESD Protection
- Halogen-Free "Green" Mold Compound
- RoHS\* Compliant

### Description

The MAMF-011069 is a dual channel module containing two 2-stage low noise amplifiers and two high power switches assembled in a 5 mm 32-lead QFN package.

This module operates from 1.8 GHz - 3.9 GHz. It features high gain and very low noise figure in the receive mode and low insertion loss in the transmission mode. The PIN switches provide high power handling over 20 W CW signal. External SMT components optimize the matching and enable flexible frequency of operation.

The MAMF-011069 is ideally suited for 4G or next generation 5G Massive MIMO or Small Cell BTS.

### Ordering Information<sup>1,2</sup>

Part Number	Package
MAMF-011069-TR1000	1000 Piece Reel
MAMF-011069-1SMB	2.6 GHz Sample Board
MAMF-011069-2SMB	3.5 GHz Sample Board

1. Reference Application Note M513 for reel size information.
2. All sample boards include 3 loose parts.

\* Restrictions on Hazardous Substances, compliant to current RoHS EU directive.

### Functional Schematic

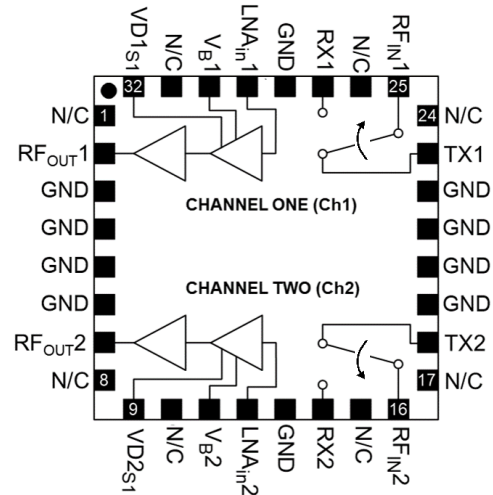

### Pin Configuration<sup>3,4</sup>

Pin #	Pin Name	Function
1, 8, 10, 15, 17, 24, 26, 31	N/C	No Connection
2	RF_OUT1	Ch1 RF Output / VD1_STAGE2
3-6, 13, 19-22, 28	GND	Ground
7	RF_OUT2	Ch2 RF Output / VD2_STAGE2
9	VD2_S1	Ch2 LNA Stage1 VD
11	V_B2	Ch2 LNA Vbias
12	LNA_IN2	Ch2 LNA Input
14	RX2	Ch2 RX / V_RX2
16	RF_IN2	Ch2 Antenna / V_ANT2
18	TX2	Ch2 TX / V_TX2
23	TX1	Ch1 TX / V_TX1
25	RF_IN1	Ch1 Antenna / V_ANT1
27	RX1	Ch1 RX / V_RX1
29	LNA_IN1	Ch1 LNA Input
30	V_B1	Ch1 LNA Vbias
32	VD1_S1	Ch1 LNA Stage1 VD
33	Paddle	Ground

3. MACOM recommends connecting unused package pins (N/C) to ground.
4. The exposed pad centered on the package bottom must be connected to RF, DC and thermal ground.

## Integrated Dual Switch - LNA Module 1.8 - 3.9 GHz

Rev. V1

### Electrical Specifications<sup>5</sup>:

Frequency = 2.6 GHz,  $T_A = 25^\circ\text{C}$ ,  $V_D = 5\text{ V}$ , Switch Bias = (see Bias Table),  $Z_0 = 50\ \Omega$

Parameter	Test Conditions	Units	Min.	Typ.	Max.
Gain RF <sub>IN</sub> - RF <sub>OUT</sub>	Rx Mode	dB	31	33	—
Noise Figure RF <sub>IN</sub> - RF <sub>OUT</sub>	Rx Mode	dB	—	1.2	—
Return Loss RF <sub>IN</sub> - RF <sub>OUT</sub>	Rx Mode	dB	—	13	—
Output IP3 RF <sub>IN</sub> - RF <sub>OUT</sub>	Rx Mode $P_{IN} = -32\text{ dBm/ tone, tone spacing } 10\text{ MHz}$	dBm	—	33	—
P1dB RF <sub>IN</sub> - RF <sub>OUT</sub>	Rx Mode	dBm	—	19	—
Isolation RF <sub>OUT1</sub> - RF <sub>OUT2</sub>	Switch State = RF <sub>IN</sub> - RF <sub>OUT</sub>	dB	—	37	—
Insertion Loss RF <sub>IN</sub> - TX	Tx Mode	dB	—	0.5	0.8
Return Loss RF <sub>IN</sub> - TX	Tx Mode	dB	—	23	—
LNA Bias Current	LNA1 Current + LNA2 Current	mA	—	210	—
Switch Current	$V_{ANT} = 5\text{ V}$ , Ch1 + Ch2 ANT Current	mA	—	45	—
RF Switching Time	—	ns	—	200	—

5. Specifications with the use of external matching components per recommended schematic for 2.6 GHz operation. Refer to schematic on page 4.

### Bias Table (See Recommended Schematic on Page 4)

RF <sub>IN</sub> - RF <sub>OUT</sub> (Rx Mode)	RF <sub>IN</sub> - TX (Tx Mode)	$V_D$	$V_{ANT}$	$V_{RX}$	$V_{TX}$
ON	OFF	5 V	5 V	0 V	28 V (0 mA)
OFF	ON	0 V	5 V	28 V (0 mA)	0 V

## Integrated Dual Switch - LNA Module 1.8 - 3.9 GHz

Rev. V1

### Absolute Maximum Ratings<sup>6,7,8,9</sup>

Parameter	Absolute Maximum
RF Input Power RF <sub>IN</sub> - RF <sub>OUT</sub> RF <sub>IN</sub> - TX	19 dBm 20 W CW
LNA Bias Voltage V <sub>B1</sub> & V <sub>B2</sub> RF <sub>OUT</sub> & VD <sub>STAGE1</sub>	5.0 V 5.5 V
Junction Temperature Switch LNA	+175°C +150°C
Operating Temperature	-40°C to +105°C
Storage Temperature	-55°C to +150°C

6. Exceeding any one or combination of these limits may cause permanent damage to this device.
7. MACOM does not recommend sustained operation near these survivability limits.
8. Operating at nominal conditions with  $T_J \leq 150^\circ\text{C}$  will ensure  $\text{MTTF} > 1 \times 10^6$  hours. Channel temperature should be kept as low as possible to maximize lifetime.
9. LNA Junction Temperature ( $T_J$ ) =  $T_C + \Theta_{JC} \cdot (V \cdot I)$   
Typical thermal resistance ( $\Theta_{JC}$ ) = 55°C/W.
  - a) For  $T_C = 25^\circ\text{C}$ ,  
 $T_J = 54^\circ\text{C} @ 5 \text{ V}, 105 \text{ mA}$
  - b) For  $T_C = 85^\circ\text{C}$ ,  
 $T_J = 113^\circ\text{C} @ 5 \text{ V}, 98 \text{ mA}$

### Handling Procedures

Please observe the following precautions to avoid damage:

### Static Sensitivity

These electronic devices are sensitive to electrostatic discharge (ESD) and can be damaged by static electricity. Proper ESD control techniques should be used when handling these HBM 1B devices.

**Recommended Schematic (2.6 GHz Operation)**

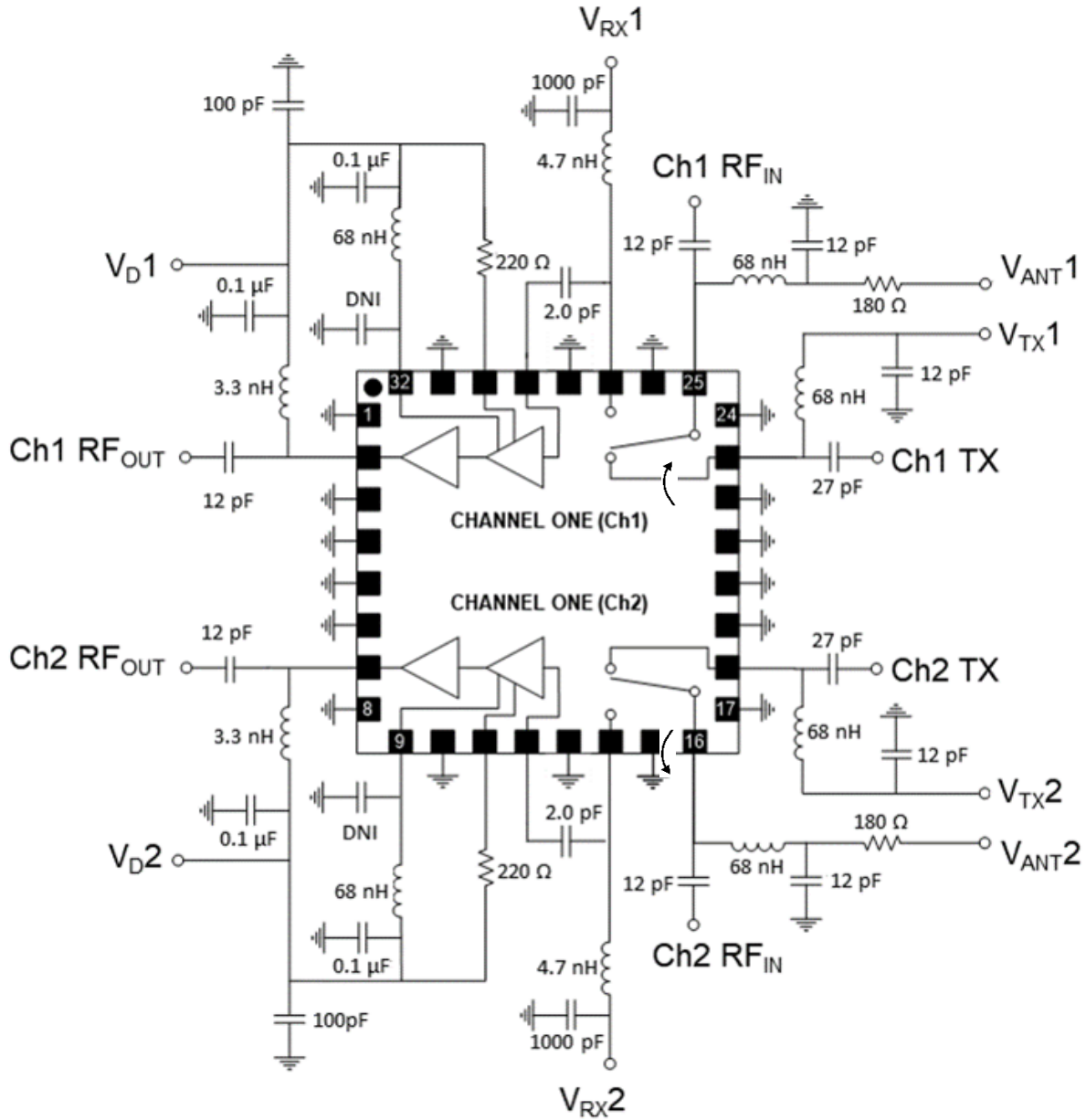

## PCB Layout - Sample Board, 2.6 GHz Operation

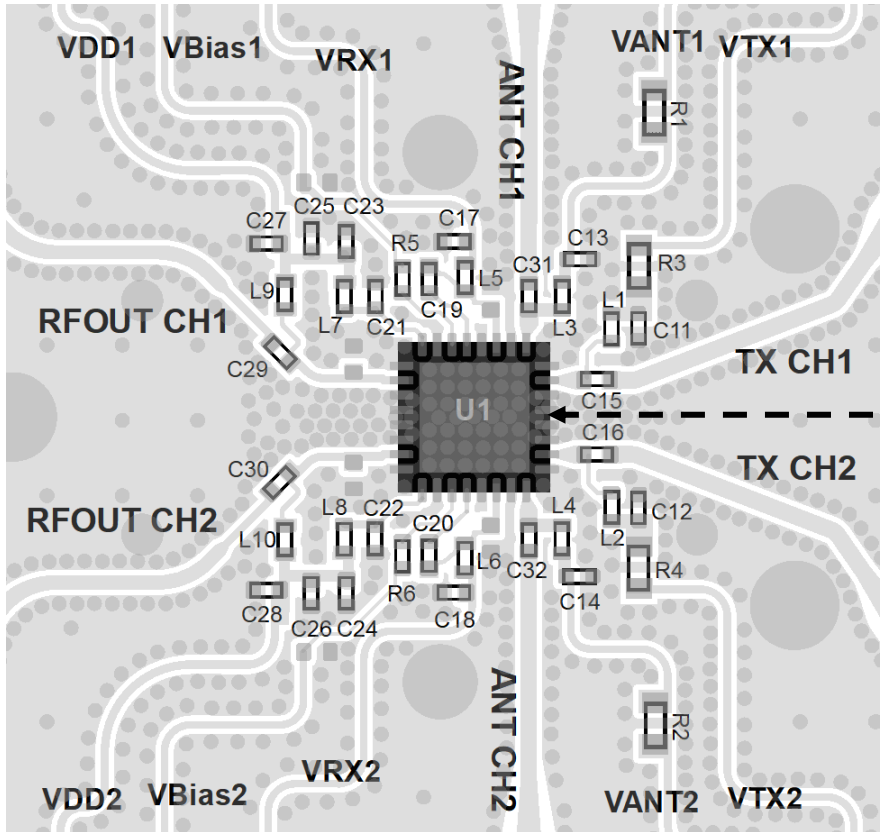

**PCB Land Pattern<sup>10</sup>**

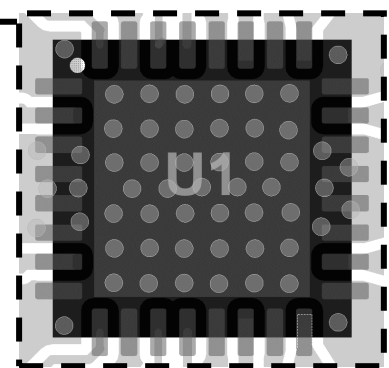

10. For best performance, ensure proper grounding at the device.

## Part List<sup>11</sup>

Component	Value	Description
C1 - C10	100 pF	0603 SMT Capacitor
C11 - C14, C29 - C32	12 pF	0402 SMT Capacitor
C15, C16	27 pF	0402 SMT Capacitor
C17, C18	1000 pF	0402 SMT Capacitor
C19, C20	2 pF	0402 SMT Capacitor
C21, C22	Do Not Populate	—
C23, C24, C27, C28	0.1 μF	0402 SMT Capacitor
C25, C26	100 pF	0402 SMT Capacitor
L1 - L4, L7, L8	68 nH	0402 Wire Wound Inductor
L5, L6	4.7 nH	0402 Wire Wound Inductor
L9, L10	3.3 nH	0402 Inductor
R1, R2	180 Ω	0402 SMT Resistor
R3, R4	0 Ω	0603 SMT Resistor
R5, R6	220 Ω	0402 SMT Resistor

11. Bypass capacitors C1 - C10 are not shown on PCB layout.

## Typical Performance Curves: 2.6 GHz Operation

**Rx Mode: Gain**

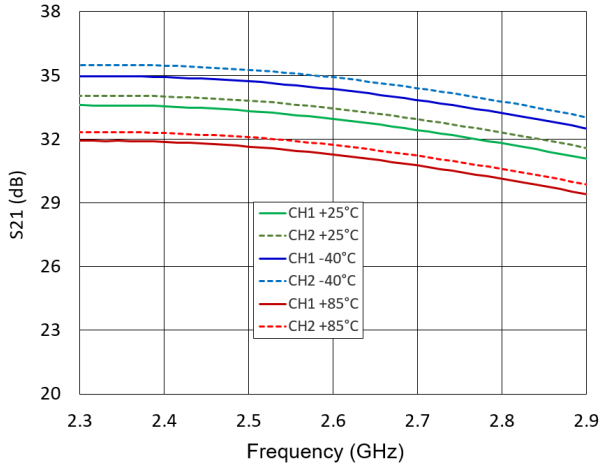

**Rx Mode: Noise Figure**

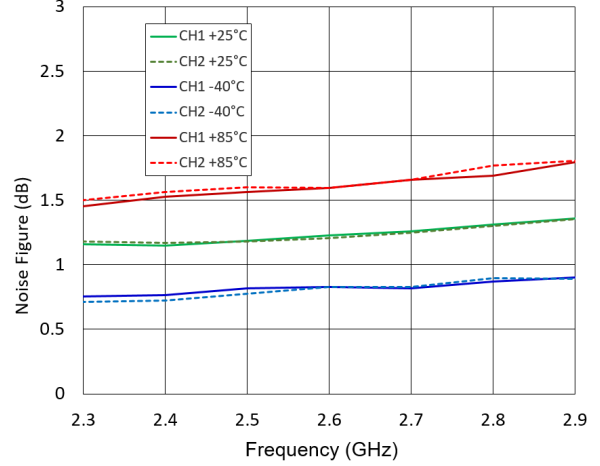

**Rx Mode: Input Return Loss**

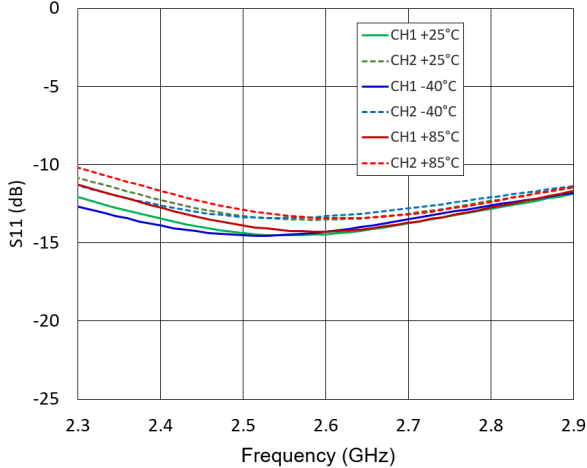

**Rx Mode: Output Return Loss**

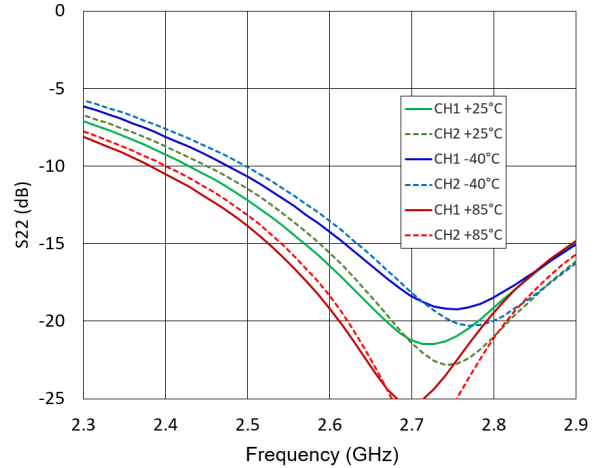

**Rx Mode: OIP3 at  $P_{IN} = -32$  dBm/tone**

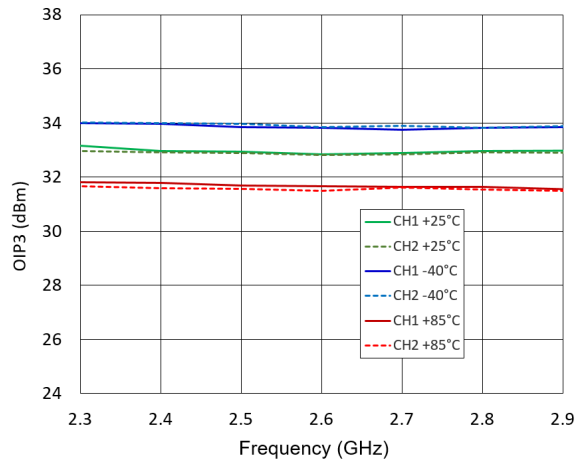

**Rx Mode: P1dB**

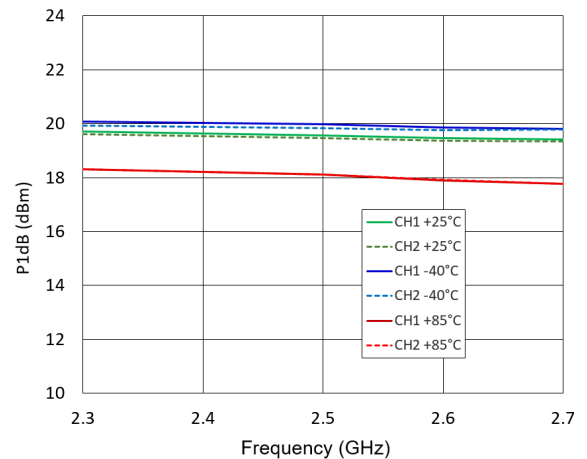

## Typical Performance Curves: 2.6 GHz Operation

**Tx Mode: Insertion Loss**

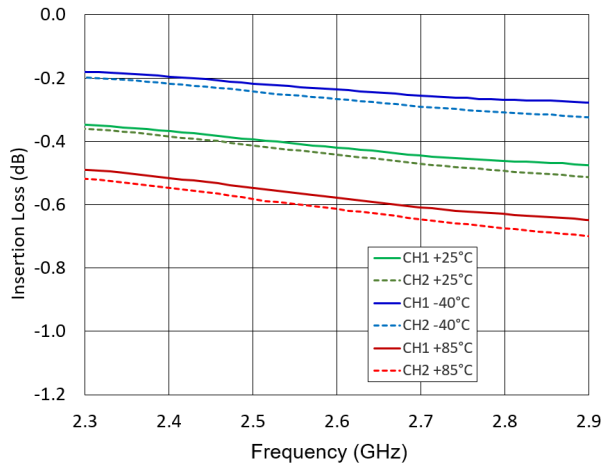

**Tx Mode: Input Return Loss**

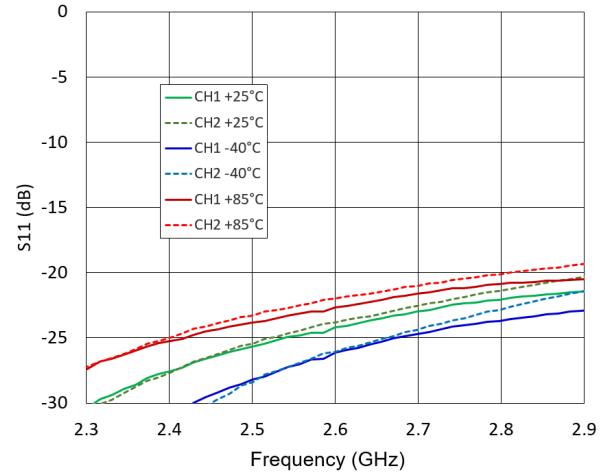

**Tx Mode: Output Return Loss**

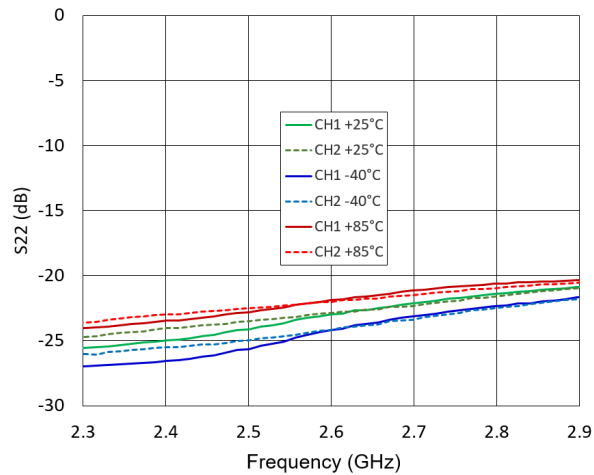

## Application Section - 3.4 - 3.6 GHz Operation

The MAMF-011069 may be tuned for operation in 3.4 - 3.6 GHz band with alternate external tuning components. Updated parts are indicated in the table below. Non - listed components are the same as in the 2.6 GHz tune on page 5.

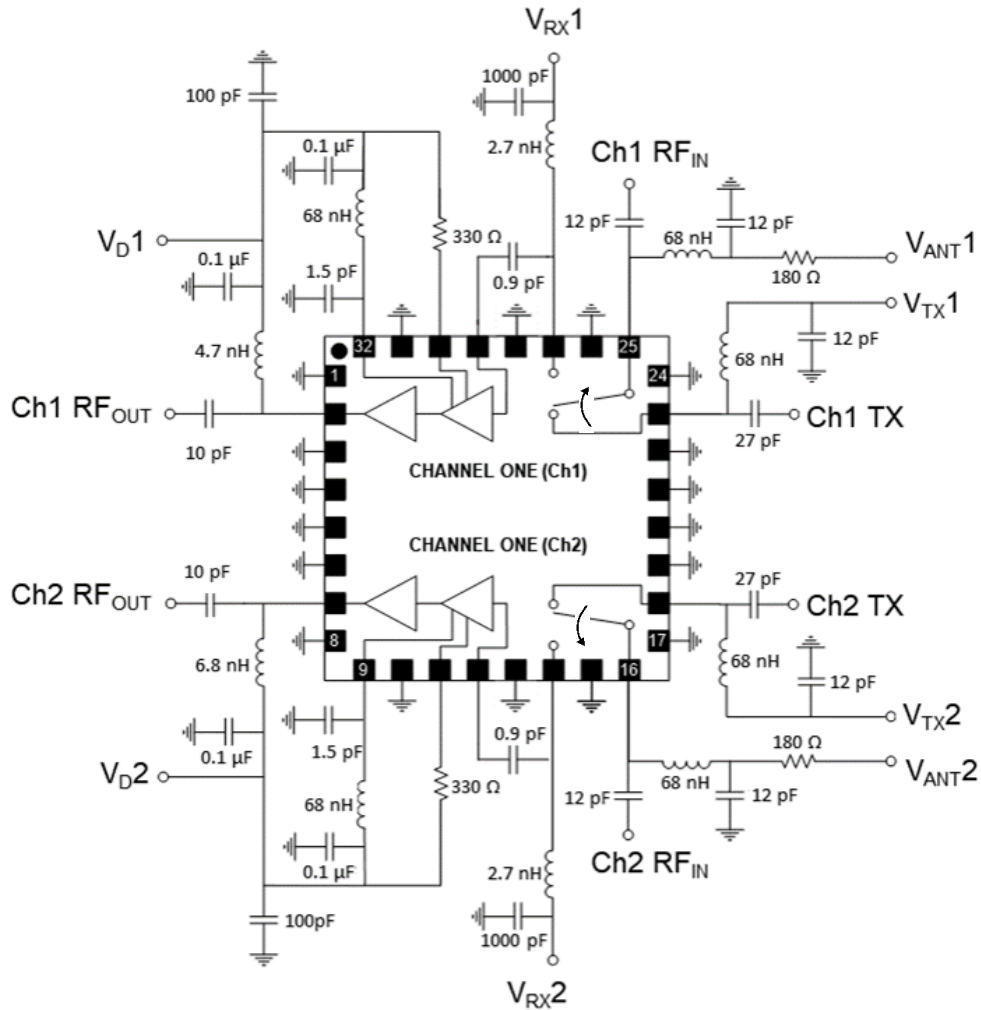

## Part List: 3.4 - 3.6 GHz Operation

Component	Value	Package
C19 , C20	0.9 pF	0402 SMT Capacitor
C21, C22	1.5 pF	0402 SMT Capacitor
L5, L6	2.7 nH	0402 Wire Wound Inductor
L9	4.7 nH	0402 Inductor
L10	6.8 nH	0402 Inductor
R5, 46	330 Ω	0402 SMT Resistor

**Typical Performance<sup>12</sup>:  $T_A = 25^\circ\text{C}$ ,  
 $V_D = 5\text{ V}$ , Switch Bias = (see Bias Table on Page 2),  $Z_0 = 50\ \Omega$ , 3.4 - 3.6 GHz Tune**

Parameter	Test Conditions	Units	Min.	Typ.	Max.
Gain RF <sub>IN</sub> - RF <sub>OUT</sub>	Rx Mode	dB	—	34	—
Noise Figure RF <sub>IN</sub> - RF <sub>OUT</sub>	Rx Mode	dB	—	1.5	—
Return Loss RF <sub>IN</sub> - RF <sub>OUT</sub>	Rx Mode: Input Output	dB	—	8 13	—
Output IP3 RF <sub>IN</sub> - RF <sub>OUT</sub>	Rx Mode $P_{IN} = -32\text{ dBm/tone}$ , tone spacing 10 MHz	dBm	—	32	—
P1dB RF <sub>IN</sub> - RF <sub>OUT</sub>	Rx Mode	dBm	—	19	—
Insertion Loss RF <sub>IN</sub> - TX	Tx Mode	dB	—	0.5	—
Return Loss RF <sub>IN</sub> - TX	Tx Mode	dB	—	19	—

12. Performance with the use of the external matching components per recommended schematic for 3.4 - 3.6 GHz operation. See schematic on page 8.

## Typical Performance Curves: 3.4 - 3.6 GHz Operation

**Rx Mode: Gain**

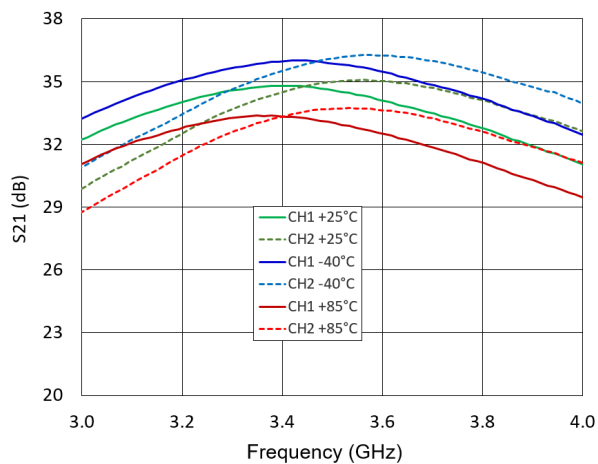

**Rx Mode: Noise Figure**

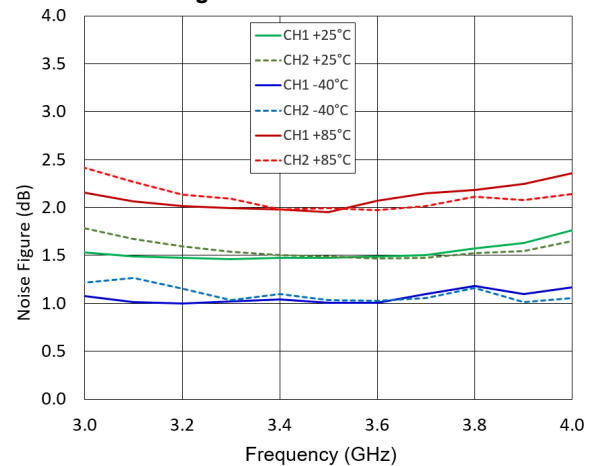

## Typical Performance Curves: 3.4 - 3.6 GHz Operation

**Rx Mode: Input Return Loss**

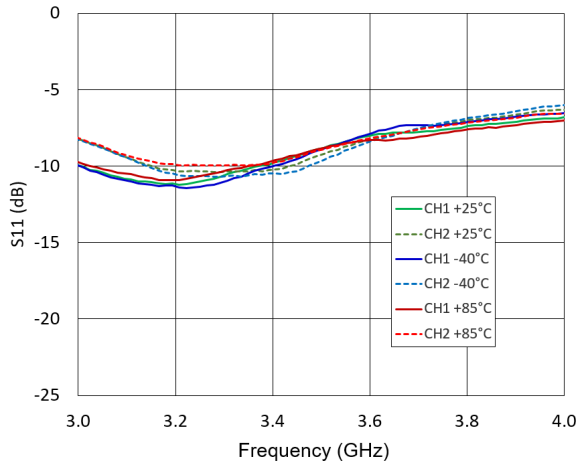

**Rx Mode: Output Return Loss**

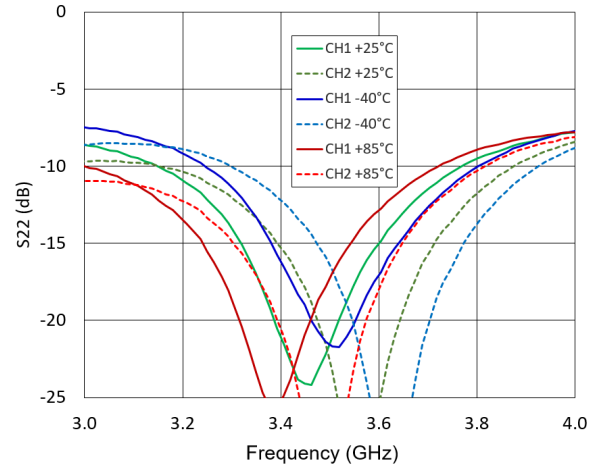

**Rx Mode: OIP3 at  $P_{IN} = -32$  dBm/tone**

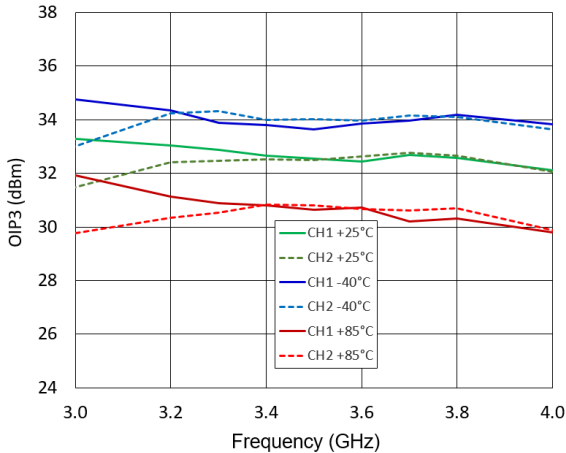

**Tx Mode: Insertion Loss**

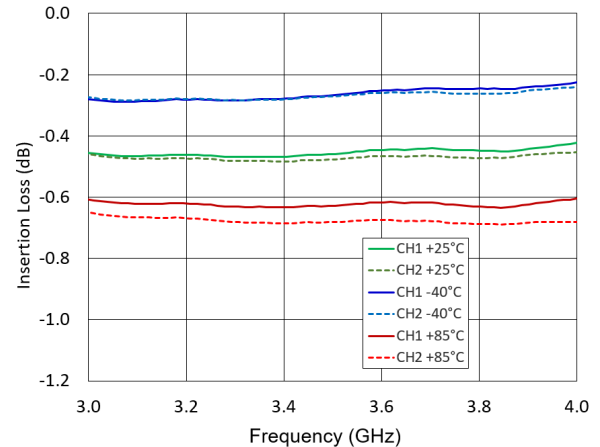

**Tx Mode: Input Return Loss**

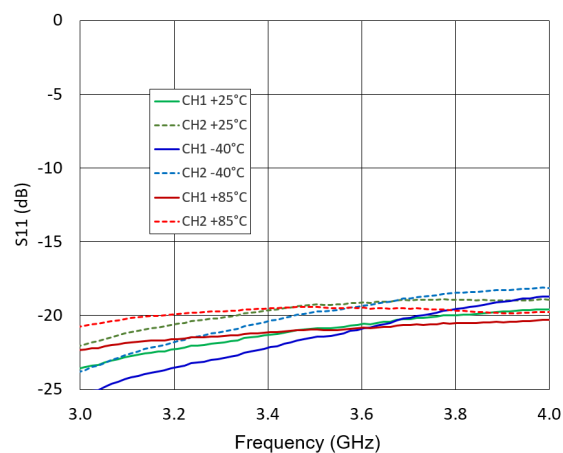

**Tx Mode: Output Return Loss**

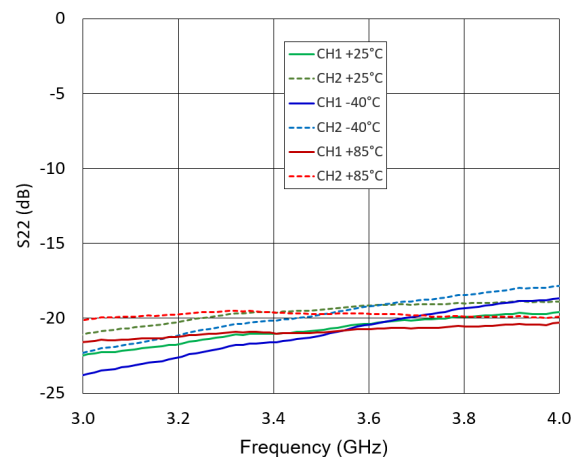



MACOM Technology Solutions Inc. All rights reserved.

Information in this document is provided in connection with MACOM Technology Solutions Inc ("MACOM") products. These materials are provided by MACOM as a service to its customers and may be used for informational purposes only. Except as provided in MACOM's Terms and Conditions of Sale for such products or in any separate agreement related to this document, MACOM assumes no liability whatsoever. MACOM assumes no responsibility for errors or omissions in these materials. MACOM may make changes to specifications and product descriptions at any time, without notice. MACOM makes no commitment to update the information and shall have no responsibility whatsoever for conflicts or incompatibilities arising from future changes to its specifications and product descriptions. No license, express or implied, by estoppel or otherwise, to any intellectual property rights is granted by this document.

THESE MATERIALS ARE PROVIDED "AS IS" WITHOUT WARRANTY OF ANY KIND, EITHER EXPRESS OR IMPLIED, RELATING TO SALE AND/OR USE OF MACOM PRODUCTS INCLUDING LIABILITY OR WARRANTIES RELATING TO FITNESS FOR A PARTICULAR PURPOSE, CONSEQUENTIAL OR INCIDENTAL DAMAGES, MERCHANTABILITY, OR INFRINGEMENT OF ANY PATENT, COPYRIGHT OR OTHER INTELLECTUAL PROPERTY RIGHT. MACOM FURTHER DOES NOT WARRANT THE ACCURACY OR COMPLETENESS OF THE INFORMATION, TEXT, GRAPHICS OR OTHER ITEMS CONTAINED WITHIN THESE MATERIALS. MACOM SHALL NOT BE LIABLE FOR ANY SPECIAL, INDIRECT, INCIDENTAL, OR CONSEQUENTIAL DAMAGES, INCLUDING WITHOUT LIMITATION, LOST REVENUES OR LOST PROFITS, WHICH MAY RESULT FROM THE USE OF THESE MATERIALS.

MACOM products are not intended for use in medical, lifesaving or life sustaining applications. MACOM customers using or selling MACOM products for use in such applications do so at their own risk and agree to fully indemnify MACOM for any damages resulting from such improper use or sale.

## Looking for pricing, stock, or lifecycle information?

Click below to explore more details on WIN SOURCE:

- ⊖ [View MAMF-011069-TR1000 on WIN SOURCE](#)
- ⊖ [M/A-Com Technology Solutions Information](#)

## Optimize Your Supply Chain with WIN SOURCE Solutions

- ✓ Global Sourcing Solution
- ✓ Obsolete Management
- ✓ Cost Control Management
- ✓ Shortage Management
- ✓ Alternative Solution
- ✓ Excess Inventory Management