

XMC4100 / XMC4200

Microcontroller Series
for Industrial Applications

XMC4000 Family

ARM[®] Cortex[®]-M4
32-bit processor core

Data Sheet

V1.5 2023-04

Microcontrollers

Edition 2023-04

**Published by
Infineon Technologies AG
81726 Munich, Germany**

**© 2023 Infineon Technologies AG
All Rights Reserved.**

Legal Disclaimer

The information given in this document shall in no event be regarded as a guarantee of conditions or characteristics. With respect to any examples or hints given herein, any typical values stated herein and/or any information regarding the application of the device, Infineon Technologies hereby disclaims any and all warranties and liabilities of any kind, including without limitation, warranties of non-infringement of intellectual property rights of any third party.

Information

For further information on technology, delivery terms and conditions and prices, please contact the nearest Infineon Technologies Office (www.infineon.com).

Warnings

Due to technical requirements, components may contain dangerous substances. For information on the types in question, please contact the nearest Infineon Technologies Office.

Infineon Technologies components may be used in life-support devices or systems only with the express written approval of Infineon Technologies, if a failure of such components can reasonably be expected to cause the failure of that life-support device or system or to affect the safety or effectiveness of that device or system. Life support devices or systems are intended to be implanted in the human body or to support and/or maintain and sustain and/or protect human life. If they fail, it is reasonable to assume that the health of the user or other persons may be endangered.

XMC4100 / XMC4200

Microcontroller Series
for Industrial Applications

XMC4000 Family

ARM[®] Cortex[®]-M4
32-bit processor core

Data Sheet

V1.5 2023-04

XMC4[12]00 Data Sheet

Revision History: V1.5 2023-04

Previous Versions:

V1.4 2018-09

V1.3 2015-10

V1.2 2014-06

V1.1 2014-03

V1.0 2013-10

V0.6 2012-11

Page	Subjects
V1.5 2023-04	
86	Deleted package details: PG-LQFP-64-19 and PG-VQFN-48-53. Added package details: PG-TQFP-64-21.
88	Deleted Table 56 and 57.
89	Added package diagram: PG-TQFP-64-21. Deleted package diagram: PG-LQFP-64-19.

Trademarks

C166™, TriCore™, XMC™ and DAVE™ are trademarks of Infineon Technologies AG.
ARM®, ARM Powered®, Cortex®, Thumb® and AMBA® are registered trademarks of ARM, Limited.

CoreSight™, ETM™, Embedded Trace Macrocell™ and Embedded Trace Buffer™ are trademarks of ARM, Limited.

Synopsys™ is a trademark of Synopsys, Inc.

We Listen to Your Comments

Is there any information in this document that you feel is wrong, unclear or missing?
Your feedback will help us to continuously improve the quality of this document.
Please send your proposal (including a reference to this document) to:

mcdocu.comments@infineon.com



Table of Contents

1	Summary of Features	8
1.1	Ordering Information	10
1.2	Device Types	10
1.3	Package Variants	11
1.4	Device Type Features	11
1.5	Definition of Feature Variants	12
1.6	Identification Registers	13
2	General Device Information	15
2.1	Logic Symbols	15
2.2	Pin Configuration and Definition	17
2.2.1	Package Pin Summary	19
2.2.2	Port I/O Functions	23
2.2.2.1	Port I/O Function Table	24
2.3	Power Connection Scheme	27
3	Electrical Parameters	29
3.1	General Parameters	29
3.1.1	Parameter Interpretation	29
3.1.2	Absolute Maximum Ratings	30
3.1.3	Pin Reliability in Overload	32
3.1.4	Pad Driver and Pad Classes Summary	34
3.1.5	Operating Conditions	35
3.2	DC Parameters	36
3.2.1	Input/Output Pins	36
3.2.2	Analog to Digital Converters (ADCx)	41
3.2.3	Digital to Analog Converters (DACx)	46
3.2.4	Out-of-Range Comparator (ORC)	49
3.2.5	High Resolution PWM (HRPWM)	51
3.2.5.1	HRC characteristics	51
3.2.5.2	CMP and 10-bit DAC characteristics	51
3.2.5.3	Clocks	54
3.2.6	Low Power Analog Comparator (LPAC)	55
3.2.7	Die Temperature Sensor	56
3.2.8	USB Device Interface DC Characteristics	57
3.2.9	Oscillator Pins	58
3.2.10	Power Supply Current	62
3.2.11	Flash Memory Parameters	66
3.3	AC Parameters	68
3.3.1	Testing Waveforms	68
3.3.2	Power-Up and Supply Monitoring	69
3.3.3	Power Sequencing	70

Table of Contents

3.3.4	Phase Locked Loop (PLL) Characteristics	72
3.3.5	Internal Clock Source Characteristics	73
3.3.6	JTAG Interface Timing	75
3.3.7	Serial Wire Debug Port (SW-DP) Timing	77
3.3.8	Peripheral Timing	78
3.3.8.1	Synchronous Serial Interface (USIC SSC) Timing	78
3.3.8.2	Inter-IC (IIC) Interface Timing	81
3.3.8.3	Inter-IC Sound (IIS) Interface Timing	83
3.3.9	USB Interface Characteristics	85
4	Package and Reliability	86
4.1	Package Parameters	86
4.1.1	Thermal Considerations	87
4.2	Package Outlines	88
5	Quality Declarations	90

About this Document

This Data Sheet is addressed to embedded hardware and software developers. It provides the reader with detailed descriptions about the ordering designations, available features, electrical and physical characteristics of the XMC4[12]00 series devices.

The document describes the characteristics of a superset of the XMC4[12]00 series devices. For simplicity, the various device types are referred to by the collective term XMC4[12]00 throughout this manual.

XMC4000 Family User Documentation

The set of user documentation includes:

- **Reference Manual**
 - describes the functionality of the superset of devices.
- **Data Sheets**
 - list the complete ordering designations, available features and electrical characteristics of derivative devices.
- **Errata Sheets**
 - list deviations from the specifications given in the related Reference Manual or Data Sheets. Errata Sheets are provided for the superset of devices.

Attention: Please consult all parts of the documentation set to attain consolidated knowledge about your device.

Application related guidance is provided by **Users Guides** and **Application Notes**.

Please refer to <http://www.infineon.com/xmc4000> to get access to the latest versions of those documents.

1 Summary of Features

The XMC4[12]00 devices are members of the XMC4000 Family of microcontrollers based on the ARM Cortex-M4 processor core. The XMC4000 is a family of high performance and energy efficient microcontrollers optimized for Industrial Connectivity, Industrial Control, Power Conversion, Sense & Control.

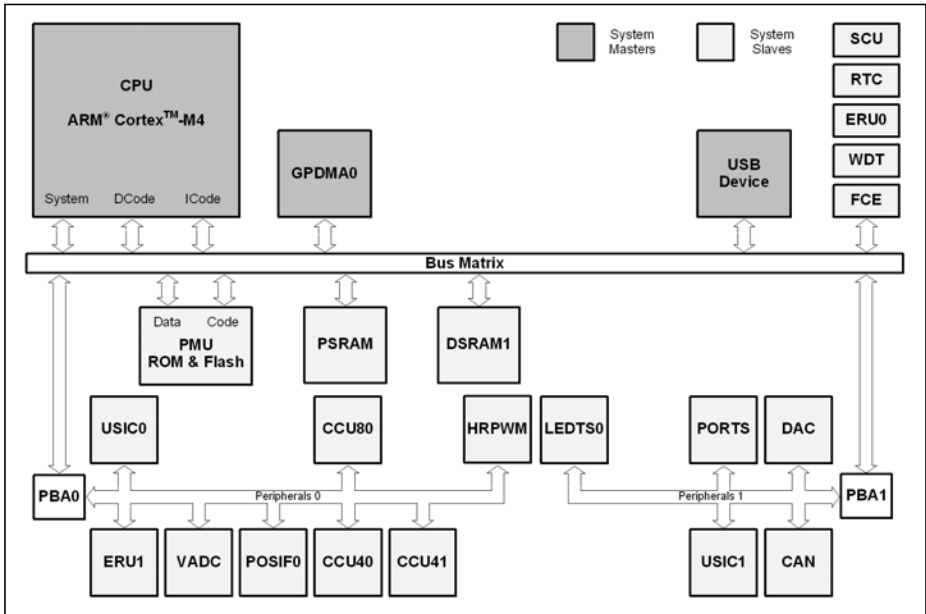

Figure 1 System Block Diagram

CPU Subsystem

- CPU Core
 - High Performance 32-bit ARM Cortex-M4 CPU
 - 16-bit and 32-bit Thumb2 instruction set
 - DSP/MAC instructions
 - System timer (SysTick) for Operating System support
- Floating Point Unit
- Memory Protection Unit
- Nested Vectored Interrupt Controller
- One General Purpose DMA with up-to 8 channels
- Event Request Unit (ERU) for programmable processing of external and internal service requests
- Flexible CRC Engine (FCE) for multiple bit error detection

On-Chip Memories

- 16 KB on-chip boot ROM
- up to 16 KB on-chip high-speed program memory
- up to 24 KB on-chip high speed data memory
- up to 256 KB on-chip Flash Memory with 1 KB instruction cache

Communication Peripherals

- Universal Serial Bus, USB 2.0 device, with integrated PHY
- Controller Area Network interface (MultiCAN), Full-CAN/Basic-CAN with two nodes, 64 message objects (MO), data rate up to 1 MBit/s
- Four Universal Serial Interface Channels (USIC), providing four serial channels, usable as UART, double-SPI, quad-SPI, IIC, IIS and LIN interfaces
- LED and Touch-Sense Controller (LEDTS) for Human-Machine interface

Analog Frontend Peripherals

- Two Analog-Digital Converters (VADC) of 12-bit resolution, 8 channels each, with input out-of-range comparators
- Digital-Analog Converter (DAC) with two channels of 12-bit resolution

Industrial Control Peripherals

- Two Capture/Compare Units 4 (CCU4) for use as general purpose timers
- One Capture/Compare Units 8 (CCU8) for motor control and power conversion
- Four High Resolution PWM (HRPWM) channels
- One Position Interface (POSIF) for servo motor positioning
- Window Watchdog Timer (WDT) for safety sensitive applications
- Die Temperature Sensor (DTS)
- Real Time Clock module with alarm support
- System Control Unit (SCU) for system configuration and control

Input/Output Lines

- Programmable port driver control module (PORTS)
- Individual bit addressability
- Tri-stated in input mode
- Push/pull or open drain output mode
- Boundary scan test support over JTAG interface

On-Chip Debug Support

- Full support for debug features: 8 breakpoints, CoreSight, trace
- Various interfaces: ARM-JTAG, SWD, single wire trace

1.1 Ordering Information

The ordering code for an Infineon microcontroller provides an exact reference to a specific product. The code “XMC4<DDD>-<Z><PPP><T><FFFF>” identifies:

- <DDD> the derivatives function set
- <Z> the package variant
 - E: LFBGA
 - F: LQFP, TQFP
 - Q: VQFN
- <PPP> package pin count
- <T> the temperature range:
 - F: -40°C to 85°C
 - K: -40°C to 125°C
- <FFFF> the Flash memory size.

For ordering codes for the XMC4[12]00 please contact your sales representative or local distributor.

This document describes several derivatives of the XMC4100 and XMC4200 series, some descriptions may not apply to a specific product. Please see [Table 1](#).

For simplicity the term **XMC4[12]00** is used for all derivatives throughout this document.

1.2 Device Types

These device types are available and can be ordered through Infineon’s direct and/or distribution channels.

Table 1 Synopsis of XMC4[12]00 Device Types

Derivative ¹⁾	Package	Flash Kbytes	SRAM Kbytes
XMC4200-F64x256	PG-yQFP-64 ²⁾	256	40
XMC4200-Q48x256	PG-VQFN-48	256	40
XMC4100-F64x128	PG-yQFP-64 ²⁾	128	20
XMC4100-Q48x128	PG-VQFN-48	128	20
XMC4104-F64x64	PG-yQFP-64 ²⁾	64	20
XMC4104-Q48x64	PG-VQFN-48	64	20
XMC4104-F64x128	PG-yQFP-64 ²⁾	128	20
XMC4104-Q48x128	PG-VQFN-48	128	20
XMC4108-F64x64	PG-yQFP-64 ²⁾	64	20
XMC4108-Q48x64	PG-VQFN-48	64	20

1) x is a placeholder for the supported temperature range.

2) y is a placeholder for the QFP package variant, LQFP or TQFP depending on the stepping, see [Section 1.3](#).

1.3 Package Variants

Different markings of the XMC4[12]00 use different package variants. Details of those packages are given in the “**Package Parameters**” section of the Data Sheet.

Table 2 XMC4[12]00 Package Variants

Package Variant	Marking	Package
XMC4[12]00-F64	EES-AA, ES-AA, ES-AB, AB	PG-LQFP-64-19
XMC4[12]00-Q48		PG-VQFN-48-53
XMC4[12]00-F64	BA	PG-TQFP-64-19
XMC4[12]00-Q48		PG-VQFN-48-71

1.4 Device Type Features

The following table lists the available features per device type.

Table 3 Features of XMC4[12]00 Device Types

Derivative ¹⁾	LEDTS Intf.	USB Intf.	USIC Chan.	MultiCAN Nodes, MO
XMC4200-F64x256	1	1	2 x 2	N0, N1 MO[0..63]
XMC4200-Q48x256	1	1	2 x 2	N0, N1 MO[0..63]
XMC4100-F64x128	1	1	2 x 2	N0, N1 MO[0..63]
XMC4100-Q48x128	1	1	2 x 2	N0, N1 MO[0..63]
XMC4104-F64x64	1	–	2 x 2	–
XMC4104-Q48x64	1	–	2 x 2	–
XMC4104-F64x128	1	–	2 x 2	–
XMC4104-Q48x128	1	–	2 x 2	–
XMC4108-F64x64	–	–	2 x 2	N0, MO[0..31]
XMC4108-Q48x64	–	–	2 x 2	N0, MO[0..31]

1) x is a placeholder for the supported temperature range.

Table 4 Features of XMC4[12]00 Device Types

Derivative ¹⁾	ADC Chan.	DAC Chan.	CCU4 Slice	CCU8 Slice	POSIF Intf.	HRPWM Intf.
XMC4200-F64x256	10	2	2 x 4	1 x 4	1	1
XMC4200-Q48x256	9	2	2 x 4	1 x 4	1	1
XMC4100-F64x128	10	2	2 x 4	1 x 4	1	1
XMC4100-Q48x128	9	2	2 x 4	1 x 4	1	1
XMC4104-F64x64	10	2	2 x 4	1 x 4	1	1
XMC4104-Q48x64	9	2	2 x 4	1 x 4	1	1
XMC4104-F64x128	10	2	2 x 4	1 x 4	1	1
XMC4104-Q48x128	9	2	2 x 4	1 x 4	1	1
XMC4108-F64x64	10	2	2 x 4	1 x 4	1	–
XMC4108-Q48x64	9	2	2 x 4	1 x 4	1	–

1) x is a placeholder for the supported temperature range.

1.5 Definition of Feature Variants

The XMC4[12]00 types are offered with several memory sizes and number of available VADC channels. [Table 5](#) describes the location of the available Flash memory, [Table 6](#) describes the location of the available SRAMs, [Table 7](#) the available VADC channels.

Table 5 Flash Memory Ranges

Total Flash Size	Cached Range	Uncached Range
256 Kbytes	0800 0000 _H – 0803 FFFF _H	0C00 0000 _H – 0C03 FFFF _H
128 Kbytes	0800 0000 _H – 0801 FFFF _H	0C00 0000 _H – 0C01 FFFF _H
64 Kbytes	0800 0000 _H – 0800 FFFF _H	0C00 0000 _H – 0C00 FFFF _H

Table 6 SRAM Memory Ranges

Total SRAM Size	Program SRAM	System Data SRAM
40 Kbytes	1FFF C000 _H – 1FFF FFFF _H	2000 0000 _H – 2000 5FFF _H
20 Kbytes	1FFF E000 _H – 1FFF FFFF _H	2000 0000 _H – 2000 2FFF _H

Table 7 ADC Channels¹⁾

Package	VADC G0	VADC G1
LQFP-64, TQFP-64	CH0, CH3..CH7	CH0, CH1, CH3, CH6
PG-VQFN-48	CH0, CH3..CH7	CH0, CH1, CH3

1) Some pins in a package may be connected to more than one channel. For the detailed mapping see the Port I/O Function table.

1.6 Identification Registers

The identification registers allow software to identify the marking.

Table 8 XMC4200 Identification Registers

Register Name	Value	Marking
SCU_IDCHIP	0004 2001 _H	EES-AA, ES-AA
SCU_IDCHIP	0004 2002 _H	ES-AB, AB
SCU_IDCHIP	0004 2003 _H	BA
JTAG IDCODE	101D D083 _H	EES-AA, ES-AA
JTAG IDCODE	201D D083 _H	ES-AB, AB
JTAG IDCODE	301D D083 _H	BA

Table 9 XMC4100 Identification Registers

Register Name	Value	Marking
SCU_IDCHIP	0004 2001 _H	EES-AA, ES-AA
SCU_IDCHIP	0004 2002 _H	ES-AB, AB
SCU_IDCHIP	0004 1003 _H	BA
JTAG IDCODE	101D D083 _H	EES-AA, ES-AA
JTAG IDCODE	201D D083 _H	ES-AB, AB
JTAG IDCODE	301D D083 _H	BA

2 General Device Information

This section summarizes the logic symbols and package pin configurations with a detailed list of the functional I/O mapping.

2.1 Logic Symbols

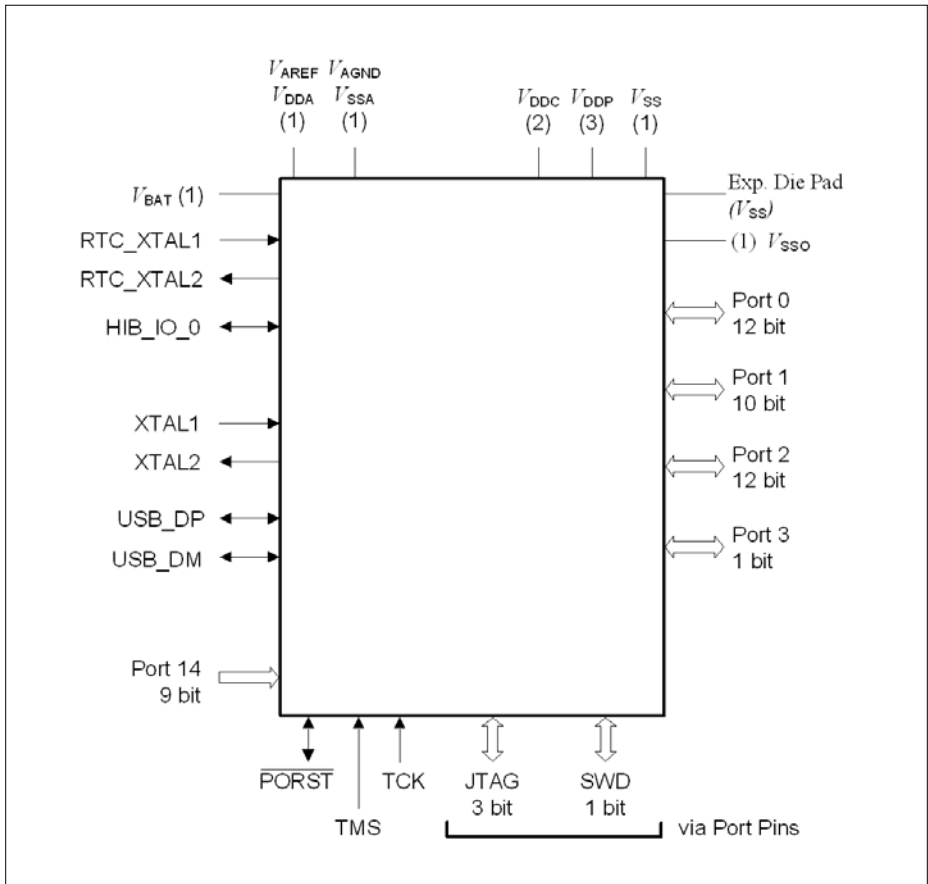

Figure 2 XMC4[12]00 Logic Symbol PG-LQFP-64 and PG-TQFP-64

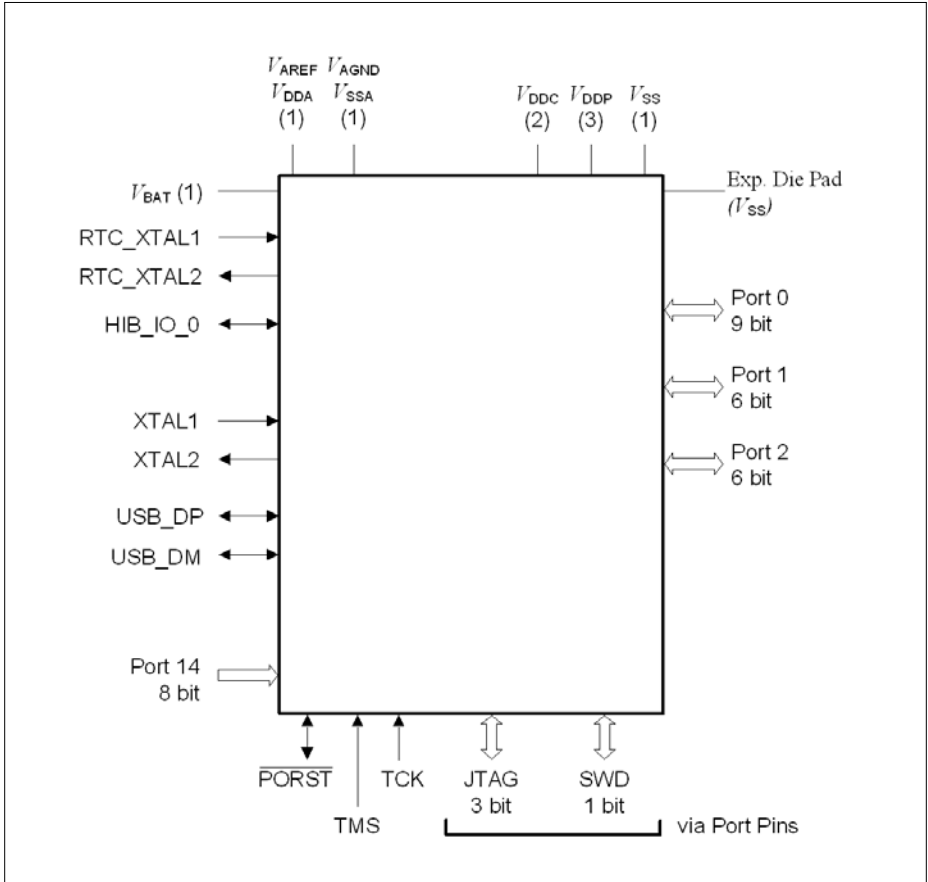

Figure 3 XMC4[12]00 Logic Symbol PG-VQFN-48

2.2 Pin Configuration and Definition

The following figures summarize all pins, showing their locations on the different packages.

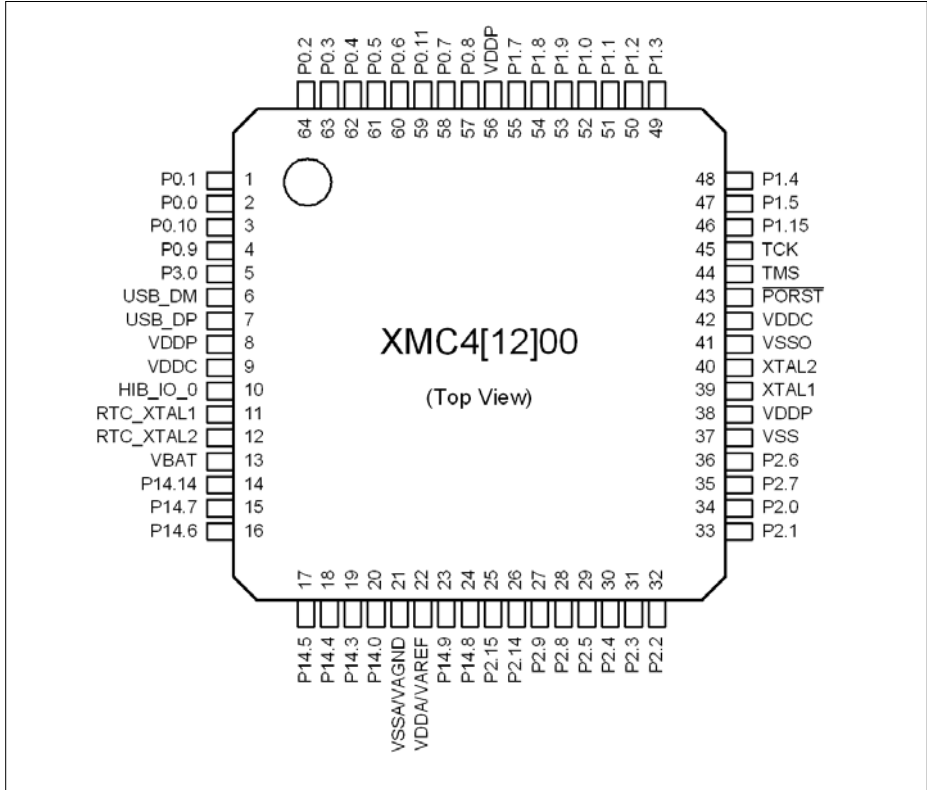

Figure 4 XMC4[12]00 PG-LQFP-64 and PG-TQFP-64 Pin Configuration (top view)

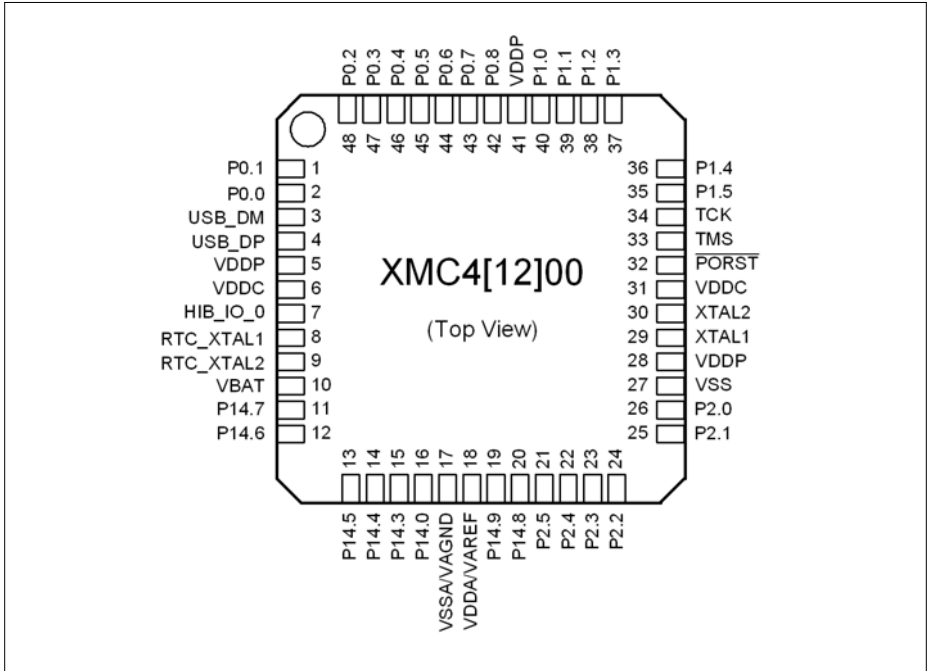

Figure 5 XMC4[12]00 PG-VQFN-48 Pin Configuration (top view)

2.2.1 Package Pin Summary

The following general scheme is used to describe each pin:

Table 10 Package Pin Mapping Description

Function	Package A	Package B	...	Pad Type	Notes
Name	N	Ax	...	A1+	

The table is sorted by the “Function” column, starting with the regular Port pins (Px.y), followed by the dedicated pins (i.e. $\overline{\text{PORST}}$) and supply pins.

The following columns, titled with the supported package variants, lists the package pin number to which the respective function is mapped in that package.

The “Pad Type” indicates the employed pad type (A1, A1+, special=special pad, In=input pad, AN/DIG_IN=analog and digital input, Power=power supply). Details about the pad properties are defined in the Electrical Parameters.

In the “Notes”, special information to the respective pin/function is given, i.e. deviations from the default configuration after reset. Per default the regular Port pins are configured as direct input with no internal pull device active.

Table 11 Package Pin Mapping

Function	LQFP-64 TQFP-64	VQFN-48	Pad Type	Notes
P0.0	2	2	A1+	
P0.1	1	1	A1+	
P0.2	64	48	A1+	
P0.3	63	47	A1+	
P0.4	62	46	A1+	
P0.5	61	45	A1+	
P0.6	60	44	A1+	
P0.7	58	43	A1+	After a system reset, via HWSEL this pin selects the DB.TDI function.
P0.8	57	42	A1+	After a system reset, via HWSEL this pin selects the DB.TRST function, with a weak pull-down active.
P0.9	4	-	A1+	
P0.10	3	-	A1+	

General Device Information

Table 11 Package Pin Mapping (cont'd)

Function	LQFP-64 TQFP-64	VQFN-48	Pad Type	Notes
P0.11	59	-	A1+	
P1.0	52	40	A1+	
P1.1	51	39	A1+	
P1.2	50	38	A1+	
P1.3	49	37	A1+	
P1.4	48	36	A1+	
P1.5	47	35	A1+	
P1.7	55	-	A1+	
P1.8	54	-	A1+	
P1.9	53	-	A1+	
P1.15	46	-	A1+	
P2.0	34	26	A1+	
P2.1	33	25	A1+	After a system reset, via HWSEL this pin selects the DB.TDO function.
P2.2	32	24	A1+	
P2.3	31	23	A1+	
P2.4	30	22	A1+	
P2.5	29	21	A1+	
P2.6	36	-	A1+	
P2.7	35	-	A1+	
P2.8	28	-	A1+	
P2.9	27	-	A1+	
P2.14	26	-	A1+	
P2.15	25	-	A1+	
P3.0	5	-	A1+	
P14.0	20	16	AN/DIG_IN	
P14.3	19	15	AN/DIG_IN	
P14.4	18	14	AN/DIG_IN	
P14.5	17	13	AN/DIG_IN	
P14.6	16	12	AN/DIG_IN	
P14.7	15	11	AN/DIG_IN	
P14.8	24	20	AN/DAC/DIG_IN	

General Device Information
Table 11 Package Pin Mapping (cont'd)

Function	LQFP-64 TQFP-64	VQFN-48	Pad Type	Notes
P14.9	23	19	AN/DAC/DIG_IN	
P14.14	14	-	AN/DIG_IN	
USB_DP	7	4	special	
USB_DM	6	3	special	
HIB_IO_0	10	7	A1 special	At the first power-up and with every reset of the hibernate domain this pin is configured as open-drain output and drives "0". As output the medium driver mode is active.
TCK	45	34	A1	Weak pull-down active.
TMS	44	33	A1+	Weak pull-up active. As output the strong-soft driver mode is active.
PORST	43	32	special	Strong pull-down controlled by EVR. Weak pull-up active while strong pull-down is not active.
XTAL1	39	29	clock_IN	
XTAL2	40	30	clock_O	
RTC_XTAL1	11	8	clock_IN	
RTC_XTAL2	12	9	clock_O	
VBAT	13	10	Power	When VDDP is supplied VBAT has to be supplied as well.
VDDA/VAREF	22	18	AN_Power/AN_Ref	Shared analog supply and reference voltage pin.
VSSA/VAGND	21	17	AN_Power/AN_Ref	Shared analog supply and reference ground pin.
VDDC	9	6	Power	
VDDC	42	31	Power	
VDDP	8	5	Power	
VDDP	38	28	Power	
VDDP	56	41	Power	
VSS	37	27	Power	

General Device Information

Table 11 Package Pin Mapping (cont'd)

Function	LQFP-64 TQFP-64	VQFN-48	Pad Type	Notes
VSSO	41	-	Power	
VSS	Exp. Pad	Exp. Pad	Power	<p>Exposed Die Pad The exposed die pad is connected internally to VSS. For proper operation, it is mandatory to connect the exposed pad directly to the common ground on the board. For thermal aspects, please refer to the Data Sheet. Board layout examples are given in an application note.</p>

2.2.2 Port I/O Functions

The following general scheme is used to describe each PORT pin:

Table 12 Port I/O Function Description

Function	Outputs			Inputs		
	ALT1	ALTn	HWO0	HWI0	Input	Input
P0.0		MODA.OUT	MODB.OUT	MODB.INA	MODC.INA	
Pn.y	MODA.OUT				MODA.INA	MODC.INB

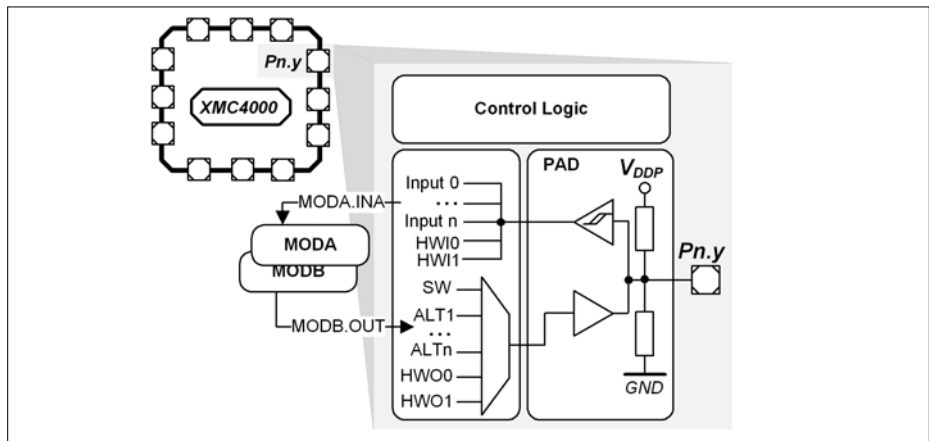

Figure 6 Simplified Port Structure

Pn.y is the port pin name, defining the control and data bits/registers associated with it. As GPIO, the port is under software control. Its input value is read via Pn_IN.y, Pn_OUT defines the output value.

Up to four alternate output functions (ALT1/2/3/4) can be mapped to a single port pin, selected by Pn_IOCR.PC. The output value is directly driven by the respective module, with the pin characteristics controlled by the port registers (within the limits of the connected pad).

The port pin input can be connected to multiple peripherals. Most peripherals have an input multiplexer to select between different possible input sources.

The input path is also active while the pin is configured as output. This allows to feedback an output to on-chip resources without wasting an additional external pin.

By Pn_HWSEL it is possible to select between different hardware “masters” (HWO0/HWI0). The selected peripheral can take control of the pin(s). Hardware control overrules settings in the respective port pin registers.

2.2.2.1 Port I/O Function Table

Table 13 Port I/O Functions

Function	Output				Input								
	ALT1	ALT2	ALT3	ALT4	HWO0	HWI0	Input	Input	Input	Input	Input	Input	Input
P0.0		CAN. NO_TXD	CCU0. OUT2	LEDTS0. COL2			U1C1. DX00	ERJ0. 0B0	USB. VBUS/DETCT A			HRP/WM0. C1NB	
P0.1		U1C1. DOU0	CCU0. OUT1	LEDTS0. COL3				ERJ0. 0A0				HRP/WM0. C2NB	
P0.2		U1C1. SELO	CCU0. OUT0	HRP/WM0. HROUT0	U1C0. DOU3	U1C0. HWI3		ERJ0. 3B3					
P0.3		U1C1. SEL0	CCU0. OUT2	HRP/WM0. HROUT20	U1C0. DOU2	U1C0. HWI2		ERJ1. 3B0					
P0.4		U1C0. DOU0	CCU0. OUT0	HRP/WM0. HROUT1	U1C0. DOU1	U1C0. HWI1		ERJ0. 2B3					
P0.5		U1C0. DOU0	CCU0. OUT0	HRP/WM0. HROUT0	U1C0. DOU0	U1C0. HWI0		ERJ1. 3A0					
P0.6		U1C0. SELO	CCU0. OUT30	HRP/WM0. HROUT30			U1C0. DX2A	ERJ0. 3B2		CCU0. IN2B			
P0.7	WM0T. SERVICE_OUT	U1C0. SELO	CCU0. OUT30	HRP/WM0. HROUT11		DB. TDI	U1C0. DX2B	ERJ0. 2B1		CCU0. IN2A	CCU0. IN2A	CCU0. IN2A	CCU0. IN2A
P0.8	SQJ. ENCLK	U1C0. SCLKOUT		HRP/WM0. HROUT0		DB. TRST	U1C0. DX1B	ERJ0. 2A1					
P0.9	HRP/WM0. HROUT31	U1C1. SELO	CCU0. OUT2	LEDTS0. COL0			U1C1. DX2A	ERJ0. 1B0					
P0.10		U1C1. SCLKOUT	CCU0. OUT2	LEDTS0. COL1			U1C1. DX1A	ERJ0. 1A0					
P0.11		U1C0. SCLKOUT	CCU0. OUT31				U1C0. DX1A	ERJ0. 3A2					
P1.0		U1C0. SELO	CCU0. OUT3	ERJ1. P0OUT3			U1C0. DX2A	ERJ0. 3B0			CCU0. IN2A	HRP/WM0. C1NA	
P1.1		U1C0. SCLKOUT	CCU0. OUT2	ERJ1. P0OUT2			U1C0. DX1A	ERJ0. 3A0		CCU0. IN2A	HRP/WM0. C1NA	HRP/WM0. C1NA	
P1.2		U1C0. MCLKOUT	CCU0. OUT1	ERJ1. P0OUT1	U1C0. DOU3	U1C0. HWI3	U1C0. IN2A	ERJ1. 2B0		CCU0. IN2A	HRP/WM0. C2NA	HRP/WM0. C2NA	
P1.3		U1C0. MCLKOUT	CCU0. OUT0	ERJ1. P0OUT0	U1C0. DOU2	U1C0. HWI2	U1C0. IN2A	ERJ1. 2A0		CCU0. IN2A	HRP/WM0. C0NB	HRP/WM0. C0NB	
P1.4	WM0T. SERVICE_OUT	CAN. NO_TXD	CCU0. OUT33		U1C0. DOU1	U1C0. HWI1	U1C0. CAN. NO_RXD0	ERJ0. 2B0			CCU0. IN2C	HRP/WM0. B0A	
P1.5	CAN. NO_TXD	U1C0. DOU0	CCU0. OUT23		U1C0. DOU0	U1C0. HWI0	U1C0. CAN. NO_RXD0A	ERJ1. 2A0			CCU0. IN2C	HRP/WM0. B0A	
P1.7		U1C0. DOU0		U1C1. SELO2				USB. VBUS/DETCT B					

Table 13 Port I/O Functions (cont'd)

Function	Output					Input								
	ALT1	ALT2	ALT3	ALT4	HWO0	HWO1	Input	Input	Input	Input	Input			
P18		UIC0_SELO1		UIC1_SCLKOUT										
P19	UIC0_SCLKOUT			UIC1_SCLKOUT										
P115	SQU_EXCLK			UIC0_DOUT0						ERU1_1A0				
P20	CAN_NO_TXD			LEDTSO_COL1					ERJ0_0B3		COJ40_IN1C			
P21				LEDTSO_COLO	DB_TDO TRACE/SWO					ERU1_0B0	COJ40_IN1C			
P22	VADC_EMUX00		COJ41_OUT0	LEDTSO_LINE0	LEDTSO_EXTENDE00	LEDTSO_TSIN0A	UIC1_DANA	ERJ0_1B2			COJ41_IN1A			
P23	VADC_EMUX01	UIC1_SELO1	COJ41_OUT2	LEDTSO_LINE1	LEDTSO_EXTENDE01	LEDTSO_TSIN1A	UIC1_DX2A	ERJ0_1A2			COJ41_IN1A			
P24	VADC_EMUX02		COJ41_OUT1	LEDTSO_LINE2	LEDTSO_EXTENDE02	LEDTSO_TSIN2A	UIC1_DX1A	ERJ0_0B2			COJ41_IN1A	HRP/WM0_B11A		
P25		UIC1_DOUT0	COJ41_OUT0	LEDTSO_LINE3	LEDTSO_EXTENDE03	LEDTSO_TSIN3A	UIC1_DX0B	ERJ0_0A2			COJ41_IN1A	HRP/WM0_B12A		
P26			COJ90_OUT0	LEDTSO_COJ3			CAN_N1_TXDA	ERJ0_1B3			COJ40_IN1C			
P27		CAN_N1_TXD	COJ90_OUT0	LEDTSO_COJ2				ERU1_1B0			COJ40_IN1C			
P28			COJ90_OUT32	LEDTSO_LINE4	LEDTSO_EXTENDE04	LEDTSO_TSIN4A	DAC_TRIGGERS				COJ40_IN1B	COJ40_IN1B	COJ40_IN1B	COJ40_IN1B
P29			COJ90_OUT22	LEDTSO_LINE5	LEDTSO_EXTENDE05	LEDTSO_TSIN5A	DAC_TRIGGERM				COJ41_IN1B	COJ41_IN1B	COJ41_IN1B	COJ41_IN1B
P214	VADC_EMUX11	UIC0_DOUT0	COJ90_OUT21				UIC0_DAN0							
P215	VADC_EMUX12		COJ90_OUT11	LEDTSO_LINE6	LEDTSO_EXTENDE06	LEDTSO_TSIN6A	UIC0_DX0C							
P30		UIC1_SCLKOUT					UIC1_DX1B				COJ80_IN1C			
P14.0							VADC_G0CH0							
P14.3							VADC_G0CH3							
P14.4							VADC_G0CH4							
P14.5							VADC_G0CH5							
P14.6							VADC_G0CH6						GOOR05	
P14.7							VADC_G0CH7							
P14.8					DAC_OUT_0		VADC_G1CH0							

Table 13 Port I/O Functions (cont'd)

Function	Output					Input									
	ALT1	ALT2	ALT3	ALT4	HWO0	HWI0	Input	Input	Input	Input	Input	Input	Input	Input	
P14.9					DMC OUT_1										
P14.14															GIORCS
USB_DP															
USB_DM															
HIB_IO_0	HIBOUT	WWDT. SERVICE_OUT					WAKEUPA					USB. VBUSDETECT C			
TCK															
TMS					DB_TMS/ SWDIO										
FORST															
XTAL1							U0C0. DX0F					U1C0. DX0F			
XTAL2															
RTC_XTAL1												ERN0. IB1			
RTC_XTAL2															

2.3 Power Connection Scheme

Figure 7 shows a reference power connection scheme for the XMC4[12]00.

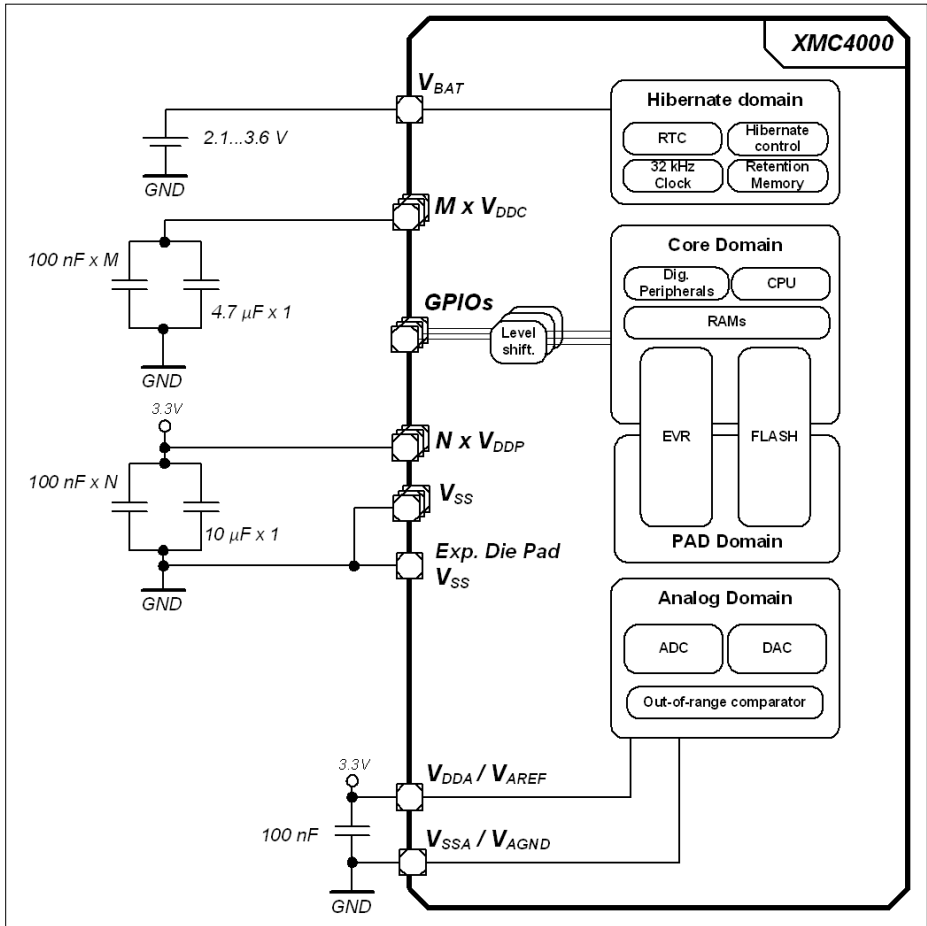

Figure 7 Power Connection Scheme

Every power supply pin needs to be connected. Different pins of the same supply need also to be externally connected. As example, all V_{DDP} pins must be connected externally to one V_{DDP} net. In this reference scheme one 100 nF capacitor is connected at each supply pin against V_{SS} . An additional 10 μ F capacitor is connected to the V_{DDP} nets and an additional 4.7uF capacitor to the V_{DDC} nets.

The XMC4[12]00 has a common ground concept, all V_{SS} , V_{SSA} and V_{SSO} pins share the same ground potential. In packages with an exposed die pad it must be connected to the common ground as well.

There are no dedicated connections for the analog reference V_{AREF} and V_{AGND} . Instead, they share the same pins as the analog supply pins V_{DDA} and V_{SSA} . Some analog channels can optionally serve as "Alternate Reference"; further details on this operating mode are described in the Reference Manual.

When V_{DDP} is supplied, V_{BAT} must be supplied as well. If no other supply source (e.g. battery) is connected to V_{BAT} , the V_{BAT} pin can also be connected directly to V_{DDP} .

3 Electrical Parameters

3.1 General Parameters

3.1.1 Parameter Interpretation

The parameters listed in this section partly represent the characteristics of the XMC4[12]00 and partly its requirements on the system. To aid interpreting the parameters easily when evaluating them for a design, they are marked with an two-letter abbreviation in column "Symbol":

- **CC**
Such parameters indicate **C**ontroller **C**haracteristics, which are a distinctive feature of the XMC4[12]00 and must be regarded for system design.
- **SR**
Such parameters indicate **S**ystem **R**equirements, which must be provided by the application system in which the XMC4[12]00 is designed in.

3.1.2 Absolute Maximum Ratings

Stresses above the values listed under “Absolute Maximum Ratings” may cause permanent damage to the device. This is a stress rating only and functional operation of the device at these or any other conditions above those indicated in the operational sections of this specification is not implied. Exposure to absolute maximum rating conditions may affect device reliability.

Table 14 Absolute Maximum Rating Parameters

Parameter	Symbol		Values			Unit	Note / Test Condition
			Min.	Typ.	Max.		
Storage temperature	T_{ST}	SR	-65	–	150	°C	–
Junction temperature	T_J	SR	-40	–	150	°C	–
Voltage at 3.3 V power supply pins with respect to V_{SS}	V_{DDP}	SR	–	–	4.3	V	–
Voltage on any Class A and dedicated input pin with respect to V_{SS}	V_{IN}	SR	-1.0	–	$V_{DDP} + 1.0$ or max. 4.3	V	whichever is lower
Voltage on any analog input pin with respect to V_{AGND}	V_{AIN} V_{AREF}	SR	-1.0	–	$V_{DDP} + 1.0$ or max. 4.3	V	whichever is lower
Input current on any pin during overload condition	I_{IN}	SR	-10	–	+10	mA	
Absolute maximum sum of all input circuit currents for one port group during overload condition ¹⁾	ΣI_{IN}	SR	-25	–	+25	mA	
Absolute maximum sum of all input circuit currents during overload condition	ΣI_{IN}	SR	-100	–	+100	mA	

1) The port groups are defined in [Table 18](#).

Figure 8 explains the input voltage ranges of V_{IN} and V_{AIN} and its dependency to the supply level of V_{DDP} . The input voltage must not exceed 4.3 V, and it must not be more than 1.0 V above V_{DDP} . For the range up to $V_{DDP} + 1.0$ V also see the definition of the overload conditions in “**Pin Reliability in Overload**”.

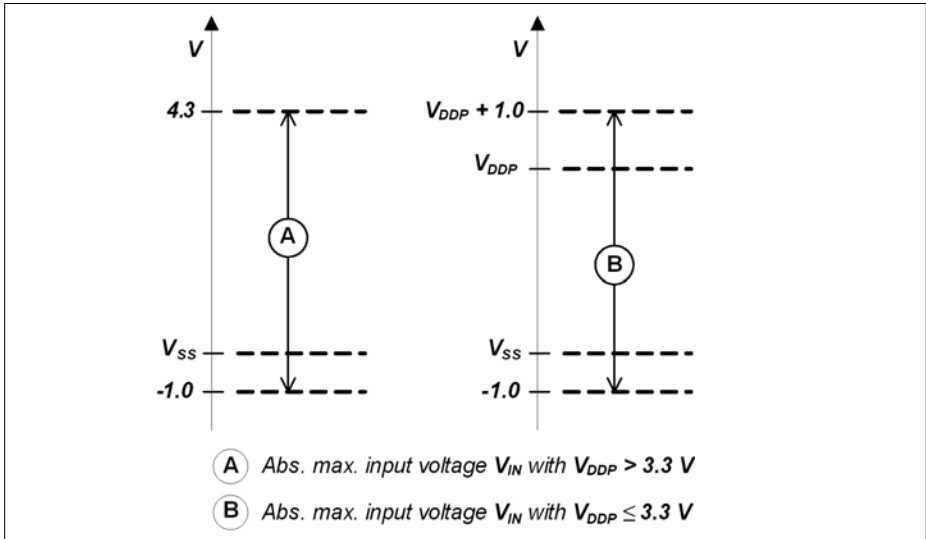

Figure 8 Absolute Maximum Input Voltage Ranges

3.1.3 Pin Reliability in Overload

When receiving signals from higher voltage devices, low-voltage devices experience overload currents and voltages that go beyond their own IO power supplies specification.

Table 15 defines overload conditions that will not cause any negative reliability impact if all the following conditions are met:

- full operation life-time is not exceeded
- **“Operating Conditions”** are met for
 - pad supply levels (V_{DDP} or V_{DDA})
 - temperature

If a pin current is outside of the **“Operating Conditions”** but within the overload parameters, then the parameters functionality of this pin as stated in the Operating Conditions can no longer be guaranteed. Operation is still possible in most cases but with relaxed parameters.

Note: An overload condition on one or more pins does not require a reset.

Note: A series resistor at the pin to limit the current to the maximum permitted overload current is sufficient to handle failure situations like short to battery.

Table 15 Overload Parameters

Parameter	Symbol	Values			Unit	Note / Test Condition
		Min.	Typ.	Max.		
Input current on any port pin during overload condition	I_{OV} SR	-5	–	5	mA	
Absolute sum of all input circuit currents for one port group during overload condition ¹⁾	I_{OVG} SR	–	–	20	mA	$\Sigma I_{OVx} $, for all $I_{OVx} < 0$ mA
		–	–	20	mA	$\Sigma I_{OVx} $, for all $I_{OVx} > 0$ mA
Absolute sum of all input circuit currents during overload condition	I_{OVS} SR	–	–	80	mA	ΣI_{OVG}

1) The port groups are defined in **Table 18**.

Figure 9 shows the path of the input currents during overload via the ESD protection structures. The diodes against V_{DDP} and ground are a simplified representation of these ESD protection structures.

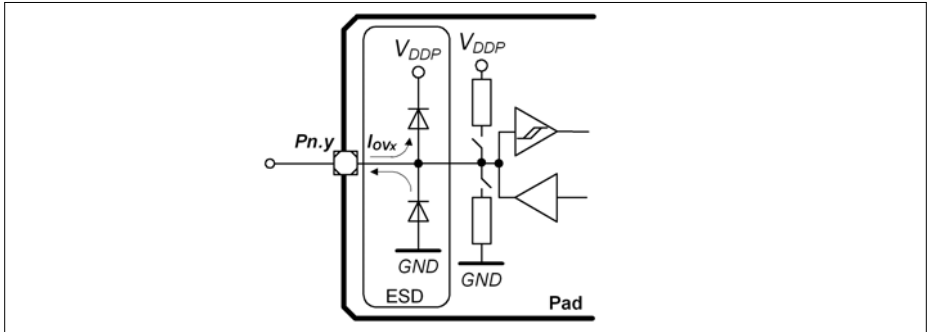

Figure 9 Input Overload Current via ESD structures

Table 16 and Table 17 list input voltages that can be reached under overload conditions. Note that the absolute maximum input voltages as defined in the “**Absolute Maximum Ratings**” must not be exceeded during overload.

Table 16 PN-Junction Characteristics for positive Overload

Pad Type	$I_{OV} = 5 \text{ mA}, T_J = -40 \text{ °C}$	$I_{OV} = 5 \text{ mA}, T_J = 150 \text{ °C}$
A1 / A1+	$V_{IN} = V_{DDP} + 1.0 \text{ V}$	$V_{IN} = V_{DDP} + 0.75 \text{ V}$
AN/DIG_IN	$V_{IN} = V_{DDP} + 1.0 \text{ V}$	$V_{IN} = V_{DDP} + 0.75 \text{ V}$

Table 17 PN-Junction Characteristics for negative Overload

Pad Type	$I_{OV} = 5 \text{ mA}, T_J = -40 \text{ °C}$	$I_{OV} = 5 \text{ mA}, T_J = 150 \text{ °C}$
A1 / A1+	$V_{IN} = V_{SS} - 1.0 \text{ V}$	$V_{IN} = V_{SS} - 0.75 \text{ V}$
AN/DIG_IN	$V_{IN} = V_{DDP} - 1.0 \text{ V}$	$V_{IN} = V_{DDP} - 0.75 \text{ V}$

Table 18 Port Groups for Overload and Short-Circuit Current Sum Parameters

Group	Pins
1	P0.[12:0], P3.0
2	P14.[8:0]
3	P2.[15:0]
4	P1.[15:0]

3.1.4 Pad Driver and Pad Classes Summary

This section gives an overview on the different pad driver classes and its basic characteristics. More details (mainly DC parameters) are defined in the **“Input/Output Pins”**.

Table 19 Pad Driver and Pad Classes Overview

Class	Power Supply	Type	Sub-Class	Speed Grade	Load	Termination
A	3.3 V	LVTTTL I/O, LVTTTL outputs	A1 (e.g. GPIO)	6 MHz	100 pF	No
			A1+ (e.g. serial I/Os)	25 MHz	50 pF	Series termination recommended

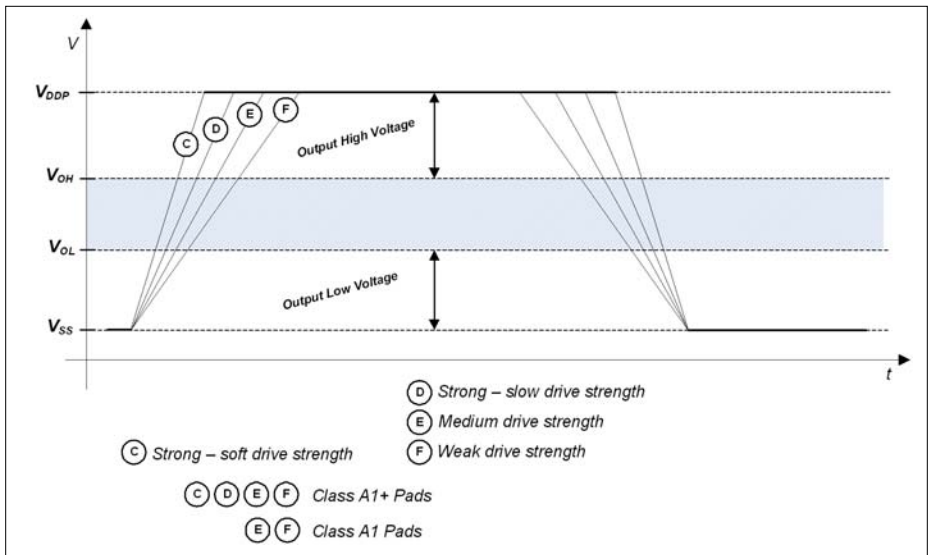

Figure 10 Output Slopes with different Pad Driver Modes

Figure 10 is a qualitative display of the resulting output slope performance with different output driver modes. The detailed input and output characteristics are listed in **“Input/Output Pins”**.

3.1.5 Operating Conditions

The following operating conditions must not be exceeded in order to ensure correct operation and reliability of the XMC4[12]00. All parameters specified in the following tables refer to these operating conditions, unless noted otherwise.

Table 20 Operating Conditions Parameters

Parameter	Symbol	Values			Unit	Note / Test Condition
		Min.	Typ.	Max.		
Ambient Temperature	T_A SR	-40	–	85	°C	Temp. Range F
		-40	–	125	°C	Temp. Range K
Digital supply voltage	V_{DDP} SR	3.13 ¹⁾	3.3	3.63 ²⁾	V	
Core Supply Voltage	V_{DDC} CC	– ¹⁾	1.3	–	V	Generated internally
Digital ground voltage	V_{SS} SR	0	–	–	V	
ADC analog supply voltage	V_{DDA} SR	3.0	3.3	3.6 ²⁾	V	
Analog ground voltage for V_{DDA}	V_{SSA} SR	-0.1	0	0.1	V	
Battery Supply Voltage for Hibernate Domain ³⁾	V_{BAT} SR	1.95 ⁴⁾	–	3.63	V	When V_{DDP} is supplied V_{BAT} has to be supplied as well.
System Frequency	f_{SYS} SR	–	–	80	MHz	
Short circuit current of digital outputs	I_{SC} SR	-5	–	5	mA	
Absolute sum of short circuit currents per pin group ⁵⁾	ΣI_{SC_PG} SR	–	–	20	mA	
Absolute sum of short circuit currents of the device	ΣI_{SC_D} SR	–	–	100	mA	

1) See also the Supply Monitoring thresholds, [Section 3.3.2](#).

2) Voltage overshoot to 4.0 V is permissible at Power-Up and \overline{PORST} low, provided the pulse duration is less than 100 μ s and the cumulated sum of the pulses does not exceed 1 h over lifetime.

3) Different limits apply for LPAC operation, [Section 3.2.6](#).

4) To start the hibernate domain it is required that $V_{BAT} \geq 2.1$ V, for a reliable start of the oscillation of RTC_XTAL in crystal mode it is required that $V_{BAT} \geq 3.0$ V.

5) The port groups are defined in [Table 18](#).

3.2 DC Parameters

3.2.1 Input/Output Pins

The digital input stage of the shared analog/digital input pins is identical to the input stage of the standard digital input/output pins.

The pull-up characteristics (I_{PUH}) and the input high and low voltage levels (V_{IH} and V_{IL}) of the $\overline{\text{PORST}}$ pin are identical to the respective values of the standard digital input/output pins.

Table 21 Standard Pad Parameters

Parameter	Symbol	Values		Unit	Note / Test Condition
		Min.	Max.		
Pin capacitance (digital inputs/outputs)	C_{IO} CC	–	10	pF	
Pull-down current	$ I_{PDL} $ SR	150	–	μA	¹⁾ $V_{IN} \geq 0.6 \times V_{DDP}$
		–	10	μA	²⁾ $V_{IN} \leq 0.36 \times V_{DDP}$
Pull-up current	$ I_{PUH} $ SR	–	10	μA	²⁾ $V_{IN} \geq 0.6 \times V_{DDP}$
		100	–	μA	¹⁾ $V_{IN} \leq 0.36 \times V_{DDP}$
Input Hysteresis for pads of all A classes ³⁾	HYS_A CC	$0.1 \times V_{DDP}$	–	V	
$\overline{\text{PORST}}$ spike filter always blocked pulse duration	t_{SF1} CC	–	10	ns	
$\overline{\text{PORST}}$ spike filter pass-through pulse duration	t_{SF2} CC	100	–	ns	
$\overline{\text{PORST}}$ pull-down current	$ I_{PPD} $ CC	13	–	mA	$V_i = 1.0 \text{ V}$

- 1) Current required to override the pull device with the opposite logic level ("force current").
With active pull device, at load currents between force and keep current the input state is undefined.
- 2) Load current at which the pull device still maintains the valid logic level ("keep current").
With active pull device, at load currents between force and keep current the input state is undefined.
- 3) Hysteresis is implemented to avoid metastable states and switching due to internal ground bounce. It can not be guaranteed that it suppresses switching due to external system noise.

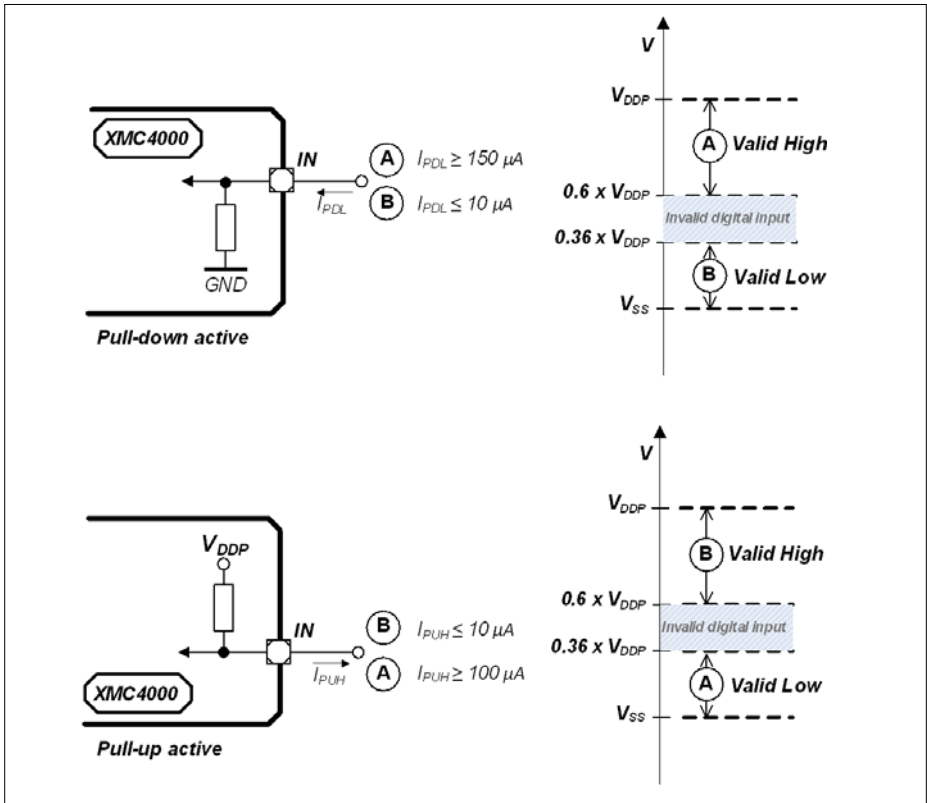

Figure 11 Pull Device Input Characteristics

Figure 11 visualizes the input characteristics with an active internal pull device:

- in the cases "A" the internal pull device is overridden by a strong external driver;
- in the cases "B" the internal pull device defines the input logical state against a weak external load.

Electrical Parameters
Table 22 Standard Pads Class_A1

Parameter	Symbol	Values		Unit	Note / Test Condition
		Min.	Max.		
Input leakage current	I_{OZA1} CC	-500	500	nA	$0\text{ V} \leq V_{IN} \leq V_{DDP}$
Input high voltage	V_{IHA1} SR	$0.6 \times V_{DDP}$	$V_{DDP} + 0.3$	V	max. 3.6 V
Input low voltage	V_{ILA1} SR	-0.3	$0.36 \times V_{DDP}$	V	
Output high voltage, POD ¹⁾ = weak	V_{OHA1} CC	$V_{DDP} - 0.4$	–	V	$I_{OH} \geq -400\ \mu\text{A}$
		2.4	–	V	$I_{OH} \geq -500\ \mu\text{A}$
Output high voltage, POD ¹⁾ = medium		$V_{DDP} - 0.4$	–	V	$I_{OH} \geq -1.4\ \text{mA}$
		2.4	–	V	$I_{OH} \geq -2\ \text{mA}$
Output low voltage	V_{OLA1} CC	–	0.4	V	$I_{OL} \leq 500\ \mu\text{A};$ POD ¹⁾ = weak
		–	0.4	V	$I_{OL} \leq 2\ \text{mA};$ POD ¹⁾ = medium
Fall time	t_{FA1} CC	–	150	ns	$C_L = 20\ \text{pF};$ POD ¹⁾ = weak
		–	50	ns	$C_L = 50\ \text{pF};$ POD ¹⁾ = medium
Rise time	t_{RA1} CC	–	150	ns	$C_L = 20\ \text{pF};$ POD ¹⁾ = weak
		–	50	ns	$C_L = 50\ \text{pF};$ POD ¹⁾ = medium

1) POD = Pin Out Driver

Table 23 Standard Pads Class_A1+

Parameter	Symbol	Values		Unit	Note / Test Condition
		Min.	Max.		
Input leakage current	I_{OZA1+} CC	-1	1	μA	$0\text{ V} \leq V_{IN} \leq V_{DDP}$
Input high voltage	V_{IHA1+} SR	$0.6 \times V_{DDP}$	$V_{DDP} + 0.3$	V	max. 3.6 V
Input low voltage	V_{ILA1+} SR	-0.3	$0.36 \times V_{DDP}$	V	

Electrical Parameters
Table 23 Standard Pads Class_A1+

Parameter	Symbol	Values		Unit	Note / Test Condition	
		Min.	Max.			
Output high voltage, POD ¹⁾ = weak	V _{OHA1+} CC	V _{DDP} - 0.4	–	V	I _{OH} ≥ -400 μA	
		2.4	–	V	I _{OH} ≥ -500 μA	
Output high voltage, POD ¹⁾ = medium		V _{DDP} - 0.4	–	V	I _{OH} ≥ -1.4 mA	
		2.4	–	V	I _{OH} ≥ -2 mA	
Output high voltage, POD ¹⁾ = strong		V _{DDP} - 0.4	–	V	I _{OH} ≥ -1.4 mA	
		2.4	–	V	I _{OH} ≥ -2 mA	
Output low voltage		V _{OLA1+} CC	–	0.4	V	I _{OL} ≤ 500 μA; POD ¹⁾ = weak
			–	0.4	V	I _{OL} ≤ 2 mA; POD ¹⁾ = medium
	–		0.4	V	I _{OL} ≤ 2 mA; POD ¹⁾ = strong	
Fall time	t _{FA1+} CC	–	150	ns	C _L = 20 pF; POD ¹⁾ = weak	
		–	50	ns	C _L = 50 pF; POD ¹⁾ = medium	
		–	28	ns	C _L = 50 pF; POD ¹⁾ = strong; edge = slow	
		–	16	ns	C _L = 50 pF; POD ¹⁾ = strong; edge = soft;	
Rise time	t _{RA1+} CC	–	150	ns	C _L = 20 pF; POD ¹⁾ = weak	
		–	50	ns	C _L = 50 pF; POD ¹⁾ = medium	
		–	28	ns	C _L = 50 pF; POD ¹⁾ = strong; edge = slow	
		–	16	ns	C _L = 50 pF; POD ¹⁾ = strong; edge = soft	

1) POD = Pin Out Driver

Table 24 HIB_IO Class_A1 special Pads

Parameter	Symbol	Values		Unit	Note / Test Condition
		Min.	Max.		
Input leakage current	I_{OZHIB} CC	-500	500	nA	$0\text{ V} \leq V_{IN} \leq V_{BAT}$
Input high voltage	V_{IHIB} SR	$0.6 \times V_{BAT}$	$V_{BAT} + 0.3$	V	max. 3.6 V
Input low voltage	V_{ILHIB} SR	-0.3	$0.36 \times V_{BAT}$	V	
Input Hysteresis for HIB_IO pins ¹⁾	$HYSHIB$ CC	$0.1 \times V_{BAT}$	–	V	$V_{BAT} \geq 3.13\text{ V}$
		$0.06 \times V_{BAT}$	–	V	$V_{BAT} < 3.13\text{ V}$
Output high voltage, POD ¹⁾ = medium	V_{OHIB} CC	$V_{BAT} - 0.4$	–	V	$I_{OH} \geq -1.4\text{ mA}$
Output low voltage	V_{OLHIB} CC	–	0.4	V	$I_{OL} \leq 2\text{ mA}$
Fall time	t_{FHIB} CC	–	50	ns	$V_{BAT} \geq 3.13\text{ V}$ $C_L = 50\text{ pF}$
		–	100	ns	$V_{BAT} < 3.13\text{ V}$ $C_L = 50\text{ pF}$
Rise time	t_{RHIB} CC	–	50	ns	$V_{BAT} \geq 3.13\text{ V}$ $C_L = 50\text{ pF}$
		–	100	ns	$V_{BAT} < 3.13\text{ V}$ $C_L = 50\text{ pF}$

1) Hysteresis is implemented to avoid metastable states and switching due to internal ground bounce. It can not be guaranteed that it suppresses switching due to external system noise.

3.2.2 Analog to Digital Converters (ADCx)
Table 25 ADC Parameters (Operating Conditions apply)

Parameter	Symbol	Values			Unit	Note / Test Condition
		Min.	Typ.	Max.		
Analog reference voltage	V_{AREF} SR	–	–	–	V	$V_{AREF} = V_{DDA}$ shared analog supply and reference input pin
Alternate reference voltage ⁵⁾	V_{AREF} SR	$V_{AGND} + 1$	–	$V_{DDA} + 0.05^{1)}$	V	
Analog reference ground	V_{AGND} SR	–	–	–	V	$V_{AGND} = V_{SSA}$ shared analog supply and reference input pin
Alternate reference voltage range ²⁾⁵⁾	$V_{AREF} - V_{AGND}$ SR	1	–	$V_{DDA} + 0.1$	V	
Analog input voltage	V_{AIN} SR	V_{AGND}	–	V_{DDA}	V	
Input leakage at analog inputs ³⁾	I_{OZ1} CC	–100	–	200	nA	$0.03 \times V_{DDA} < V_{AIN} < 0.97 \times V_{DDA}$
		–500	–	100	nA	$0 \text{ V} \leq V_{AIN} \leq 0.03 \times V_{DDA}$
		–100	–	500	nA	$0.97 \times V_{DDA} \leq V_{AIN} \leq V_{DDA}$
Internal ADC clock	f_{ADCI} CC	2	–	30	MHz	$V_{DDA} = 3.3 \text{ V}$
Switched capacitance at the analog voltage inputs ⁴⁾	C_{AINSW} CC	–	4	6.5	pF	
Total capacitance of an analog input	C_{AINTOT} CC	–	12	20	pF	
Switched capacitance at the alternate reference voltage input ⁵⁾⁶⁾	C_{AREFSW} CC	–	15	30	pF	

Electrical Parameters
Table 25 ADC Parameters (Operating Conditions apply)

Parameter	Symbol	Values			Unit	Note / Test Condition
		Min.	Typ.	Max.		
Total capacitance of the alternate reference inputs ⁵⁾	$C_{AREFTOT}$ CC	–	20	40	pF	
Total Unadjusted Error	TUE CC	-6	–	6	LSB	12-bit resolution; $V_{DDA} = 3.3\text{ V}$; $V_{AREF} = V_{DDA}$ ⁷⁾
Differential Non-Linearity Error ⁸⁾	EA_{DNL} CC	-4.5	–	4.5	LSB	
Gain Error ⁸⁾	EA_{GAIN} CC	-6	–	6	LSB	
Integral Non-Linearity ⁸⁾	EA_{INL} CC	-4.5	–	4.5	LSB	
Offset Error ⁸⁾	EA_{OFF} CC	-6	–	6	LSB	
RMS Noise ⁹⁾	EN_{RMS} CC	–	1	2 ¹⁰⁾ 11)	LSB	
Worst case ADC V_{DDA} power supply current per active converter	I_{DDAA} CC	–	1.5	2	mA	during conversion $V_{DDP} = 3.6\text{ V}$, $T_J = 150\text{ °C}$
Charge consumption on alternate reference per conversion ⁵⁾	Q_{CONV} CC	–	30	–	pC	$0\text{ V} \leq V_{AREF} \leq V_{DDA}$ ¹²⁾
ON resistance of the analog input path	R_{AIN} CC	–	600	1 200	Ohm	
ON resistance for the ADC test (pull down for AIN7)	R_{AIN7T} CC	180	550	900	Ohm	

- 1) A running conversion may become imprecise in case the normal conditions are violated (voltage overshoot).
- 2) If the analog reference voltage is below V_{DDA} , then the ADC converter errors increase. If the reference voltage is reduced by the factor k ($k < 1$), TUE, DNL, INL, Gain, and Offset errors increase also by the factor $1/k$.
- 3) The leakage current definition is a continuous function, as shown in figure ADCx Analog Inputs Leakage. The numerical values defined determine the characteristic points of the given continuous linear approximation - they do not define step function (see [Figure 14](#)).
- 4) The sampling capacity of the conversion C-network is pre-charged to $V_{AREF}/2$ before the sampling moment. Because of the parasitic elements, the voltage measured at AINx can deviate from $V_{AREF}/2$.
- 5) Applies to AINx, when used as alternate reference input.
- 6) This represents an equivalent switched capacitance. This capacitance is not switched to the reference voltage at once. Instead, smaller capacitances are successively switched to the reference voltage.
- 7) For 10-bit conversions, the errors are reduced to 1/4; for 8-bit conversions, the errors are reduced to 1/16. Never less than ± 1 LSB.

Electrical Parameters

- 8) The sum of DNL/INL/GAIN/OFF errors does not exceed the related total unadjusted error TUE.
- 9) This parameter is valid for soldered devices and requires careful analog board design.
- 10) Resulting worst case combined error is arithmetic combination of TUE and EN_{RMS} .
- 11) Value is defined for one sigma Gauss distribution.
- 12) The resulting current for a conversion can be calculated with $I_{AREF} = Q_{CONV} / t_c$.
The fastest 12-bit post-calibrated conversion of $t_c = 566$ ns results in a typical average current of $I_{AREF} = 53 \mu A$.

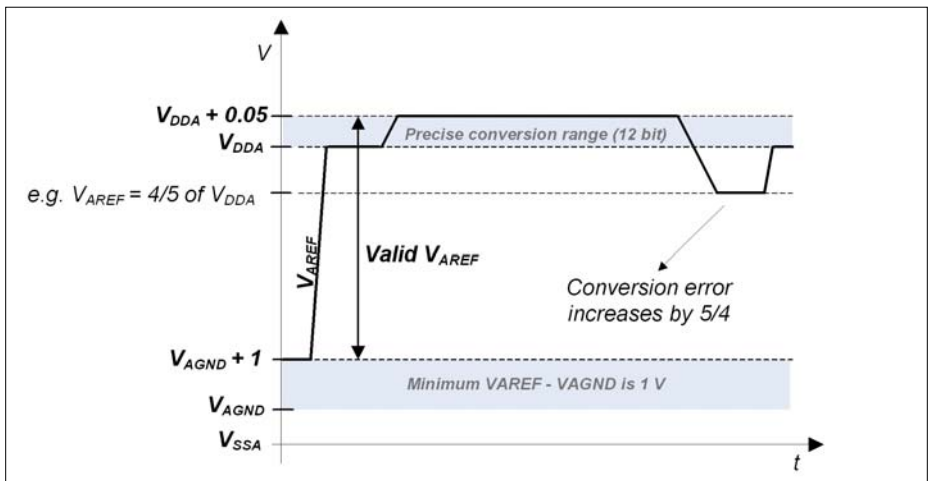

Figure 12 VADC Reference Voltage Range

Electrical Parameters

The power-up calibration of the ADC requires a maximum number of $4 \cdot 352 \cdot f_{\text{ADCI}}$ cycles.

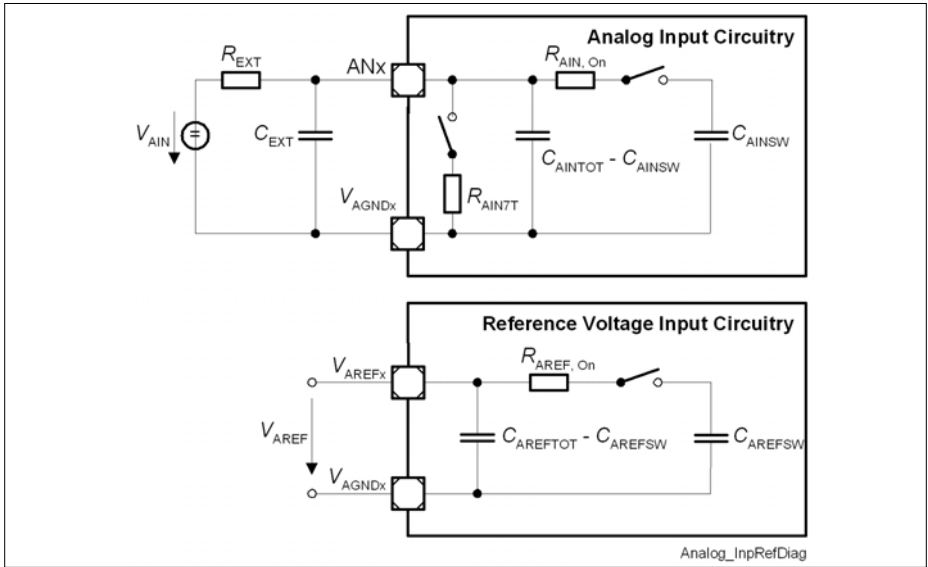

Figure 13 ADCx Input Circuits

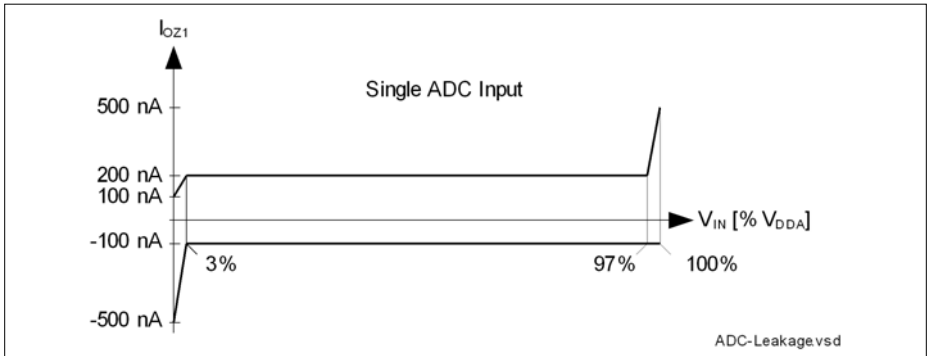

Figure 14 ADCx Analog Input Leakage Current

Conversion Time
Table 26 Conversion Time (Operating Conditions apply)

Parameter	Symbol	Values	Unit	Note
Conversion time	t_C CC	$2 \times T_{ADC} + (2 + N + STC + PC + DM) \times T_{ADCI}$	μs	N = 8, 10, 12 for N-bit conversion $T_{ADC} = 1 / f_{PERIPH}$ $T_{ADCI} = 1 / f_{ADCI}$

- STC defines additional clock cycles to extend the sample time
- PC adds two cycles if post-calibration is enabled
- DM adds one cycle for an extended conversion time of the MSB

Conversion Time Examples

System assumptions (max. f_{ADC}):

$$f_{ADC} = 80 \text{ MHz i.e. } t_{ADC} = 12.5 \text{ ns, DIVA} = 2, f_{ADCI} = 26.7 \text{ MHz i.e. } t_{ADCI} = 37.5 \text{ ns}$$

According to the given formulas the following minimum conversion times can be achieved (STC = 0, DM = 0):

12-bit post-calibrated conversion (PC = 2):

$$t_{CN12C} = (2 + 12 + 2) \times t_{ADCI} + 2 \times t_{ADC} = 16 \times 37.5 \text{ ns} + 2 \times 12.5 \text{ ns} = 625 \text{ ns}$$

12-bit uncalibrated conversion:

$$t_{CN12} = (2 + 12) \times t_{ADCI} + 2 \times t_{ADC} = 14 \times 37.5 \text{ ns} + 2 \times 12.5 \text{ ns} = 550 \text{ ns}$$

10-bit uncalibrated conversion:

$$t_{CN10} = (2 + 10) \times t_{ADCI} + 2 \times t_{ADC} = 12 \times 37.5 \text{ ns} + 2 \times 12.5 \text{ ns} = 475 \text{ ns}$$

8-bit uncalibrated:

$$t_{CN8} = (2 + 8) \times t_{ADCI} + 2 \times t_{ADC} = 10 \times 37.5 \text{ ns} + 2 \times 12.5 \text{ ns} = 400 \text{ ns}$$

System assumptions (max. f_{ADCI}):

$$f_{ADC} = 60 \text{ MHz i.e. } t_{ADC} = 16.67 \text{ ns, DIVA} = 1, f_{ADCI} = 30 \text{ MHz i.e. } t_{ADCI} = 33.33 \text{ ns}$$

12-bit post-calibrated conversion (PC = 2):

$$t_{CN12C} = (2 + 12 + 2) \times t_{ADCI} + 2 \times t_{ADC} = 16 \times 33.33 \text{ ns} + 2 \times 16.67 \text{ ns} = 566 \text{ ns}$$

3.2.3 Digital to Analog Converters (DACx)

Note: These parameters are not subject to production test, but verified by design and/or characterization.

Table 27 DAC Parameters (Operating Conditions apply)

Parameter	Symbol	Values			Unit	Note / Test Condition
		Min.	Typ.	Max.		
RMS supply current	I_{DD} CC	–	2.5	4	mA	per active DAC channel, without load currents of DAC outputs
Resolution	RES CC	–	12	–	Bit	
Update rate	f_{URATE_A} CC	–		2	Msample/s	data rate, where DAC can follow 64 LSB code jumps to ± 1 LSB accuracy
Update rate	f_{URATE_F} CC	–		5	Msample/s	data rate, where DAC can follow 64 LSB code jumps to ± 4 LSB accuracy
Settling time	t_{SETTLE} CC	–	1	2	μ s	at full scale jump, output voltage reaches target value ± 20 LSB
Slew rate	SR CC	2	5	–	V/ μ s	
Minimum output voltage	V_{OUT_MIN} CC	–	0.3	–	V	code value unsigned: 000 _H ; signed: 800 _H
Maximum output voltage	V_{OUT_MAX} CC	–	2.5	–	V	code value unsigned: FFF _H ; signed: 7FF _H
Integral non-linearity ¹⁾	INL CC	-5.5	± 2.5	5.5	LSB	$R_L \geq 5$ kOhm, $C_L \leq 50$ pF
Differential non-linearity	DNL CC	-2	± 1	2	LSB	$R_L \geq 5$ kOhm, $C_L \leq 50$ pF

Electrical Parameters
Table 27 DAC Parameters (Operating Conditions apply) (cont'd)

Parameter	Symbol	Values			Unit	Note / Test Condition
		Min.	Typ.	Max.		
Offset error	ED_{OFF} CC		±20		mV	
Gain error	ED_{G_IN} CC	-5	0	5	%	
Startup time	$t_{STARTUP}$ CC	–	15	30	µs	time from output enabling till code valid ±16 LSB
3dB Bandwidth of Output Buffer	f_{C1} CC	2.5	5	–	MHz	verified by design
Output sourcing current	I_{OUT_SOURCE} CC	–	-30	–	mA	
Output sinking current	I_{OUT_SINK} CC	–	0.6	–	mA	
Output resistance	R_{OUT} CC	–	50	–	Ohm	
Load resistance	R_L SR	5	–	–	kOhm	
Load capacitance	C_L SR	–	–	50	pF	
Signal-to-Noise Ratio	SNR CC	–	70	–	dB	examination bandwidth < 25 kHz
Total Harmonic Distortion	THD CC	–	70	–	dB	examination bandwidth < 25 kHz
Power Supply Rejection Ratio	PSRR CC	–	56	–	dB	to V_{DDA} verified by design

1) According to best straight line method.

Conversion Calculation

Unsigned:

$$DACxDATA = 4095 \times (V_{OUT} - V_{OUT_MIN}) / (V_{OUT_MAX} - V_{OUT_MIN})$$

Signed:

$$DACxDATA = 4095 \times (V_{OUT} - V_{OUT_MIN}) / (V_{OUT_MAX} - V_{OUT_MIN}) - 2048$$

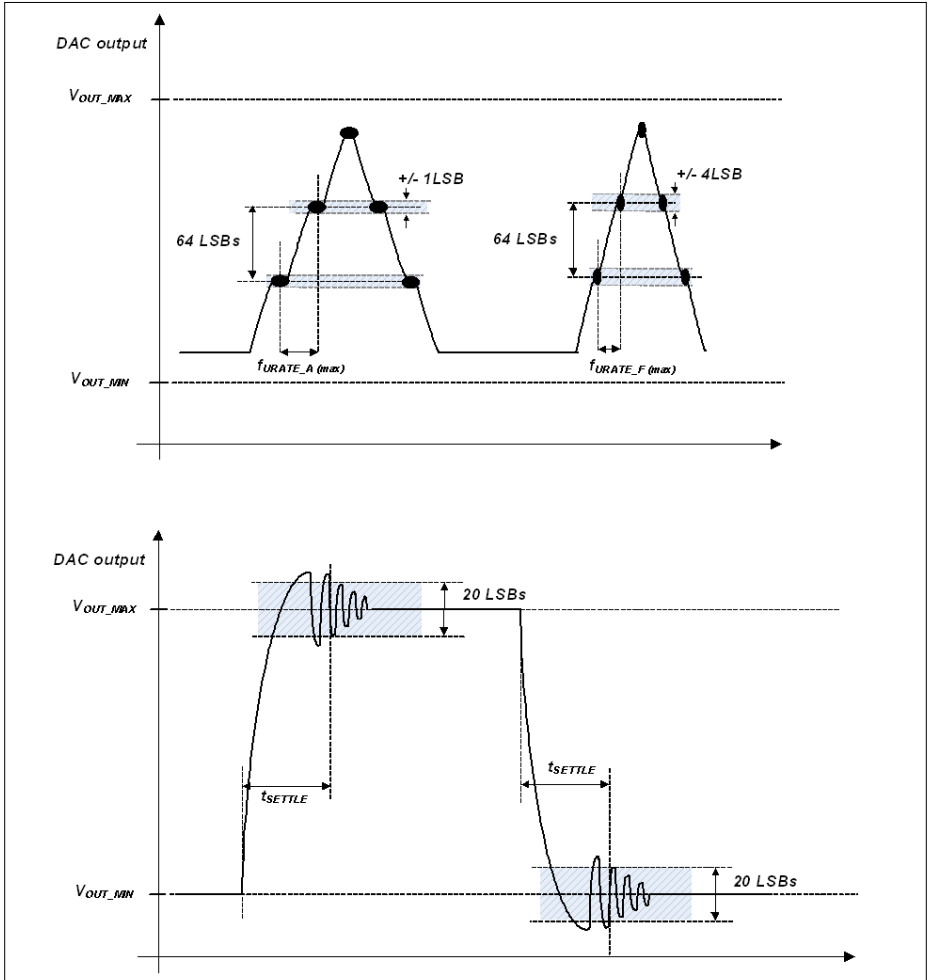

Figure 15 DAC Conversion Examples

3.2.4 Out-of-Range Comparator (ORC)

The Out-of-Range Comparator (ORC) triggers on analog input voltages (V_{AIN}) above the analog reference¹⁾ (V_{AREF}) on selected input pins (GxORCy) and generates a service request trigger (GxORCOUTy).

Note: These parameters are not subject to production test, but verified by design and/or characterization.

The parameters in **Table 28** apply for the maximum reference voltage $V_{AREF} = V_{DDA} + 50$ mV.

Table 28 ORC Parameters (Operating Conditions apply)

Parameter	Symbol		Values			Unit	Note / Test Condition
			Min.	Typ.	Max.		
DC Switching Level	V_{ODC}	CC	100	125	200	mV	Ax-marking devices $V_{AIN} \geq V_{AREF} + V_{ODC}$
Hysteresis	V_{OHYS}	CC	50	–	V_{ODC}	mV	
Detection Delay of a persistent Overvoltage	t_{ODD}	CC	55	–	450	ns	Ax-marking devices $V_{AIN} \geq V_{AREF} + 200$ mV
			45	–	105	ns	$V_{AIN} \geq V_{AREF} + 400$ mV
Always detected Overvoltage Pulse	t_{OPDD}	CC	440	–	–	ns	Ax-marking devices $V_{AIN} \geq V_{AREF} + 200$ mV
			90	–	–	ns	$V_{AIN} \geq V_{AREF} + 400$ mV
Never detected Overvoltage Pulse	t_{OPDN}	CC	–	–	49	ns	Ax-marking devices $V_{AIN} \geq V_{AREF} + 200$ mV
			–	–	30	ns	$V_{AIN} \geq V_{AREF} + 400$ mV
Release Delay	t_{ORD}	CC	65	–	105	ns	$V_{AIN} \leq V_{AREF}$
Enable Delay	t_{OED}	CC	–	100	200	ns	

1) Always the standard VADC reference, alternate references do not apply to the ORC.

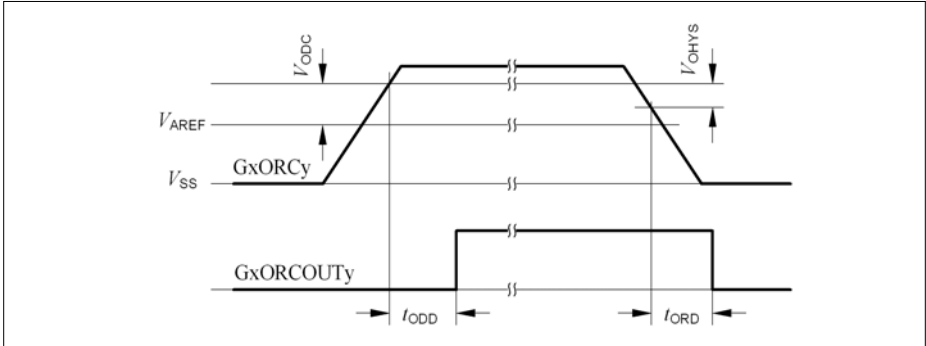

Figure 16 GxORCOUTy Trigger Generation

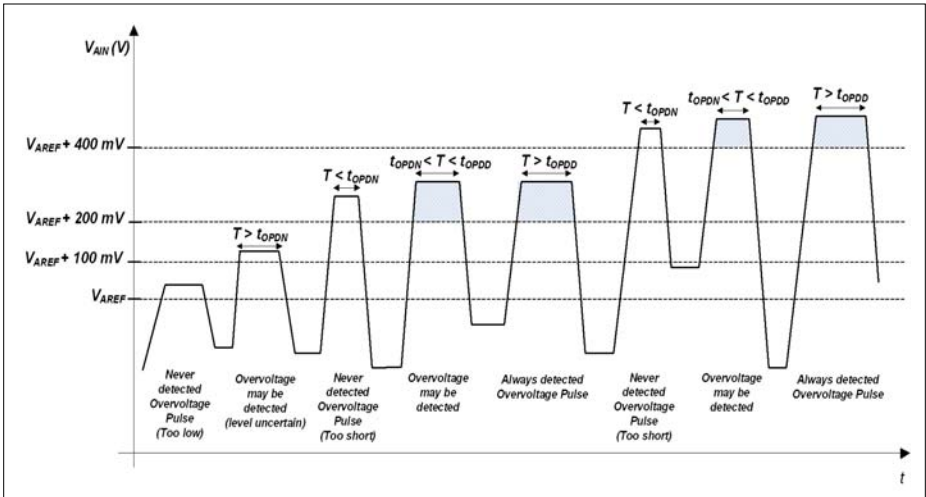

Figure 17 ORC Detection Ranges

3.2.5 High Resolution PWM (HRPWM)

The following chapters describe the operating conditions, characteristics and timing requirements, for all the components inside the HRPWM module. Each description is given for just one sub unit, e.g., one CSG or one HRC.

All the timing information is related to the module clock, f_{hrpwm} .

Note: These parameters are not subject to production test, but verified by design and/or characterization.

3.2.5.1 HRC characteristics

Table 29 summarizes the characteristics of the HRC units.

Table 29 HRC characteristics (Operating Conditions apply)

Parameter	Symbol	Values			Unit	Note / Test Condition
		Min.	Typ.	Max.		
High resolution step size ¹⁾²⁾	t_{HRS} CC	–	150	–	ps	
Startup time (after reset release)	t_{start} CC	–	–	2	μs	

1) The step size for clock frequencies equal to 180, 120 and 80 MHz is 150 ps.

2) The step size for clock frequencies different from 180, 120 and 80 MHz but within the range from 180 to 64 MHz can be between 118 to 180 ps (fixed over process and operating conditions)

3.2.5.2 CMP and 10-bit DAC characteristics

The **Table 30** summarizes the characteristics of the CSG unit.

The specified characteristics require that the setup of the HRPWM follows the initialization sequence as documented in the Reference Manual.

Table 30 CMP and 10-bit DAC characteristics (Operating Conditions apply)

Parameter	Symbol	Values			Unit	Note / Test Condition
		Min.	Typ.	Max.		
DAC Resolution	RES CC		10		bits	
DAC differential nonlinearity	DNL CC	-1	–	1.5	LSB	Monotonic behavior See Figure 18
DAC integral nonlinearity	INL CC	-3	–	3	LSB	See Figure 18

Electrical Parameters
Table 30 CMP and 10-bit DAC characteristics (Operating Conditions apply)

Parameter	Symbol	Values			Unit	Note / Test Condition
		Min.	Typ.	Max.		
CSG Output Jitter	D_{CSG} CC	–	–	1	clk	
Bias startup time	t_{start} CC	–	–	98	us	
Bias supply current	I_{DDbias} CC	–	–	400	μA	
CSGy startup time	t_{CSGS} CC	–	–	2	μs	
Input operation current ¹⁾	I_{DDCIN} CC	-10	–	33	μA	See Figure 19
High Speed Mode						
DAC output voltage range	V_{DOUT} CC	V_{SS}	–	V_{DDP}	V	
DAC propagation delay - Full scale	t_{FShs} CC	–	–	80	ns	See Figure 20
Input Selector propagation delay - Full scale	t_{Dhs} CC	–	–	100	ns	See Figure 20
Comparator bandwidth	t_{Dhs} CC	20	–	–	ns	
DAC CLK frequency	f_{clk} SR	–	–	30	MHz	
Supply current	I_{DDhs} CC	–	–	940	μA	
Low Speed Mode						
DAC output voltage range	V_{DOUT} CC	$0.1 \times V_{DDP}^{2)}$	–	V_{DDP}	V	
DAC propagation delay - Full Scale	t_{FSls} CC	–	–	160	ns	See Figure 20
Input Selector propagation delay - Full Scale	t_{Dis} CC	–	–	200	ns	See Figure 20
Comparator bandwidth	t_{Dis} CC	20	–	–	ns	
DAC CLK frequency	f_{clk} SR	–	–	30	MHz	
Supply current	I_{DDls} CC	–	–	300	μA	

1) Typical input resistance $R_{CIN} = 100k\Omega$.

2) The INL error increases for DAC output voltages below this limit.

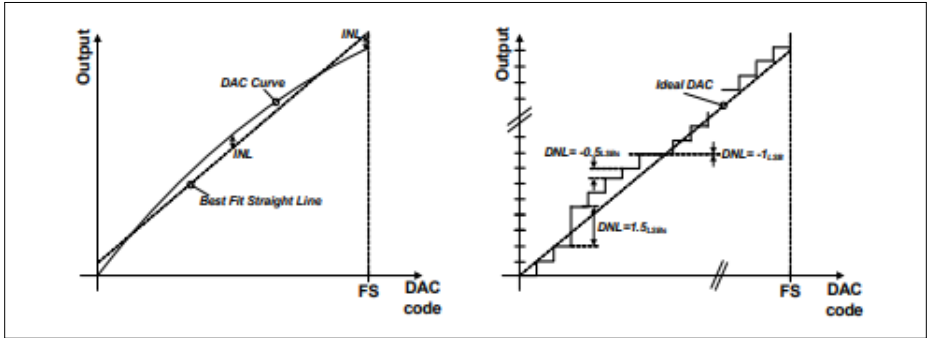

Figure 18 CSG DAC INL and DNL example

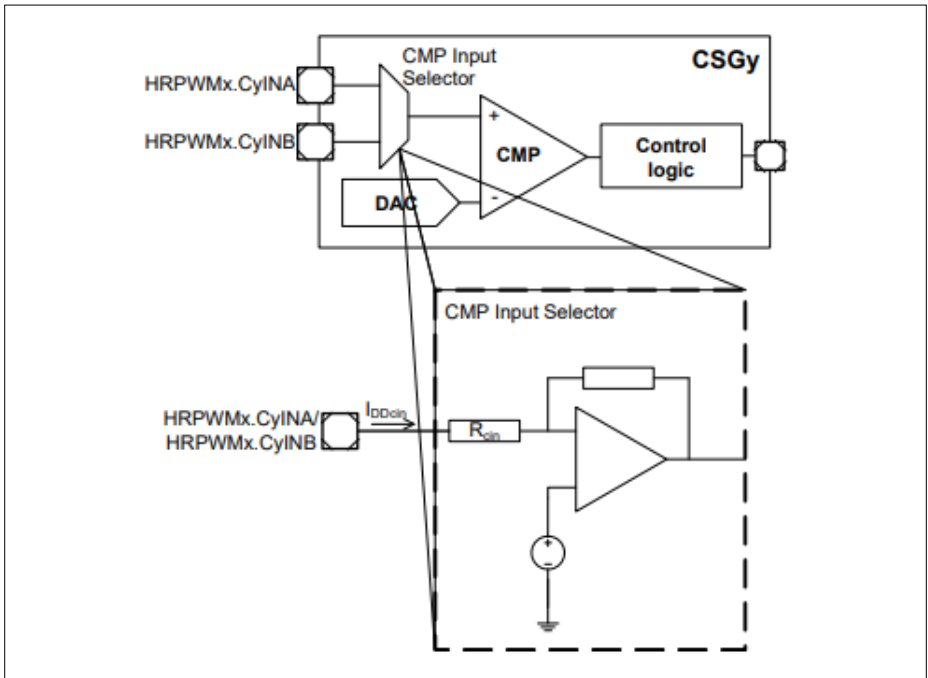

Figure 19 Input operation current

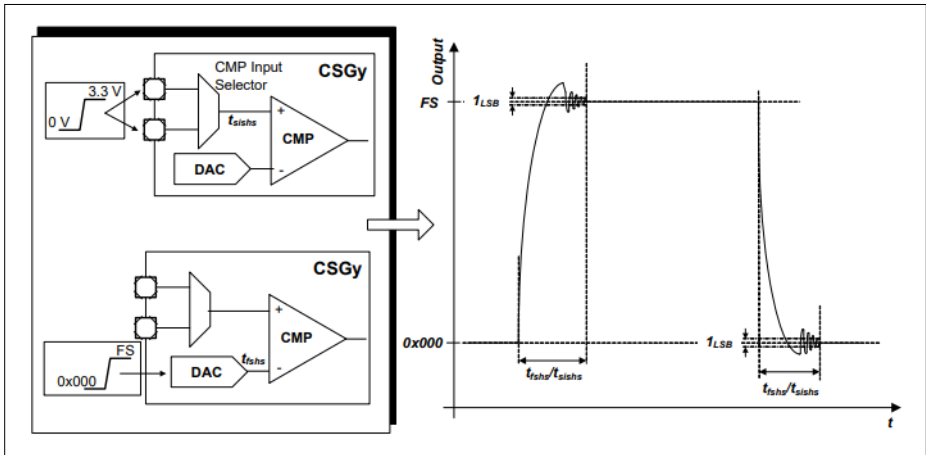

Figure 20 DAC and Input Selector Propagation Delay

3.2.5.3 Clocks

HRPWM DAC Conversion Clock

The DAC conversion clock can be generated internally or it can be controlled via a HRPWM module pin.

Table 31 External DAC conversion trigger operating conditions

Parameter	Symbol	Values			Unit	Note / Test Condition
		Min.	Typ.	Max.		
Frequency	f_{etrg} SR	–	–	30 ²⁾	MHz	
ON time	t_{onetrg} SR	$2T_{ccu}^{1)2)}$	–	–	ns	
OFF time	$t_{offetrg}$ SR	$2T_{ccu}^{1)2)}$	–	–	ns	

1) 50% duty cycle is not obligatory

2) Only valid if the signal was not previously synchronized/generated with the fccu clock (or a synchronous clock)

CSG External Clock

It is possible to select an external source, that can be used as a clock for the slope generation, HRPWMx.ECLKy. This clock is synchronized internally with the module clock and therefore the external clock needs to meet the criterion described on [Table 32](#).

Table 32 External clock operating conditions

Parameter	Symbol	Values			Unit	Note / Test Condition
		Min.	Typ.	Max.		
Frequency	f_{eck} SR	–	–	$f_{\text{hrpwm}}/4$	MHz	
ON time	t_{oneck} SR	$2T_{\text{ccu}}^{1)2)}$	–	–	ns	
OFF time	t_{offeck} SR	$2T_{\text{ccu}}^{1)2)}$	–	–	ns	Only the rising edge is used

1) 50% duty cycle is not obligatory

2) Only valid if the signal was not previously synchronized/generated with the fccu clock (or a synchronous clock)

3.2.6 Low Power Analog Comparator (LPAC)

The Low Power Analog Comparator (LPAC) triggers a wake-up event from Hibernate state or an interrupt trigger during normal operation. It does so by comparing V_{BAT} or another external sensor voltage V_{LPS} with a pre-programmed threshold voltage.

Note: These parameters are not subject to production test, but verified by design and/or characterization.

Table 33 Low Power Analog Comparator Parameters

Parameter	Symbol	Values			Unit	Note / Test Condition
		Min.	Typ.	Max.		
V_{BAT} supply voltage range for LPAC operation	V_{BAT} SR	2.1	–	3.6	V	
Sensor voltage range	V_{LPCS} CC	0	–	1.2	V	
Threshold step size	V_{th} CC	–	18.75	–	mV	
Threshold trigger accuracy	ΔV_{th} CC	–	–	± 10	%	for $V_{\text{th}} > 0.4 \text{ V}$
Conversion time	t_{LPCC} CC	–	–	250	μs	
Average current consumption over time	I_{LPCAC} CC	–	–	15	μA	conversion interval 10 ms ¹⁾
Current consumption during conversion	I_{LPCC} CC	–	150	–	μA	¹⁾

1) Single channel conversion, measuring $V_{\text{BAT}} = 3.3 \text{ V}$, 8 cycles settling time

3.2.7 Die Temperature Sensor

The Die Temperature Sensor (DTS) measures the junction temperature T_J .

Note: These parameters are not subject to production test, but verified by design and/or characterization.

Table 34 Die Temperature Sensor Parameters

Parameter	Symbol	Values			Unit	Note / Test Condition
		Min.	Typ.	Max.		
Temperature sensor range	T_{SR} SR	-40	–	150	°C	
Linearity Error (to the below defined formula)	ΔT_{LE} CC	–	±1	–	°C	per $\Delta T_J \leq 30$ °C
Offset Error	ΔT_{OE} CC	–	±6	–	°C	$\Delta T_{OE} = T_J - T_{DTS}$ $V_{DDP} \leq 3.3$ V ¹⁾
Measurement time	t_M CC	–	–	100	µs	
Start-up time after reset inactive	t_{TSST} SR	–	–	10	µs	

1) At $V_{DDP_max} = 3.63$ V the typical offset error increases by an additional $\Delta T_{OE} = \pm 1$ °C.

The following formula calculates the temperature measured by the DTS in [°C] from the RESULT bit field of the DTSSTAT register.

$$\text{Temperature } T_{DTS} = (\text{RESULT} - 605) / 2.05 \text{ [°C]}$$

This formula and the values defined in [Table 34](#) apply with the following calibration values:

- DTSCON.BGTRIM = 8_H
- DTSCON.REFTRIM = 4_H

3.2.8 USB Device Interface DC Characteristics

The Universal Serial Bus (USB) Interface is compliant to the USB Rev. 2.0 Specification. High-Speed Mode is not supported.

Note: These parameters are not subject to production test, but verified by design and/or characterization.

Table 35 USB Device Data Line (USB_DP, USB_DM) Parameters (Operating Conditions apply)

Parameter	Symbol	Values			Unit	Note / Test Condition
		Min.	Typ.	Max.		
Input low voltage	V_{IL} SR	–	–	0.8	V	
Input high voltage (driven)	V_{IH} SR	2.0	–	–	V	
Input high voltage (floating) ¹⁾	V_{IHZ} SR	2.7	–	3.6	V	
Differential input sensitivity	V_{DIS} CC	0.2	–	–	V	
Differential common mode range	V_{CM} CC	0.8	–	2.5	V	
Output low voltage	V_{OL} CC	0.0	–	0.3	V	1.5 kOhm pull-up to 3.6 V
Output high voltage	V_{OH} CC	2.8	–	3.6	V	15 kOhm pull-down to 0 V
DP pull-up resistor (idle bus)	R_{PUI} CC	900	–	1 575	Ohm	
DP pull-up resistor (upstream port receiving)	R_{PUA} CC	1 425	–	3 090	Ohm	
Input impedance DP, DM	Z_{INP} CC	300	–	–	kOhm	$0\text{ V} \leq V_{IN} \leq V_{DDP}$
Driver output resistance DP, DM	Z_{DRV} CC	28	–	44	Ohm	

1) Measured at A-connector with 1.5 kOhm \pm 5% to 3.3 V \pm 0.3 V connected to USB_DP or USB_DM and at B-connector with 15 kOhm \pm 5% to ground connected to USB_DP and USB_DM.

3.2.9 Oscillator Pins

Note: It is strongly recommended to measure the oscillation allowance (negative resistance) in the final target system (layout) to determine the optimal parameters for the oscillator operation. Please refer to the limits specified by the crystal or ceramic resonator supplier.

Note: These parameters are not subject to production test, but verified by design and/or characterization.

The oscillator pins can be operated with an external crystal (see [Figure 21](#)) or in direct input mode (see [Figure 22](#)).

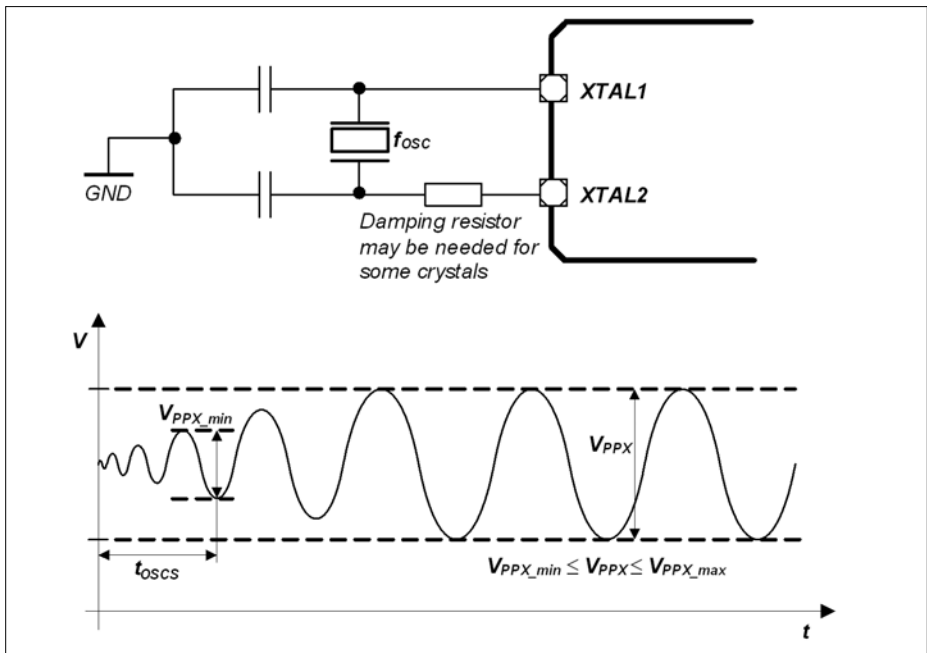

Figure 21 Oscillator in Crystal Mode

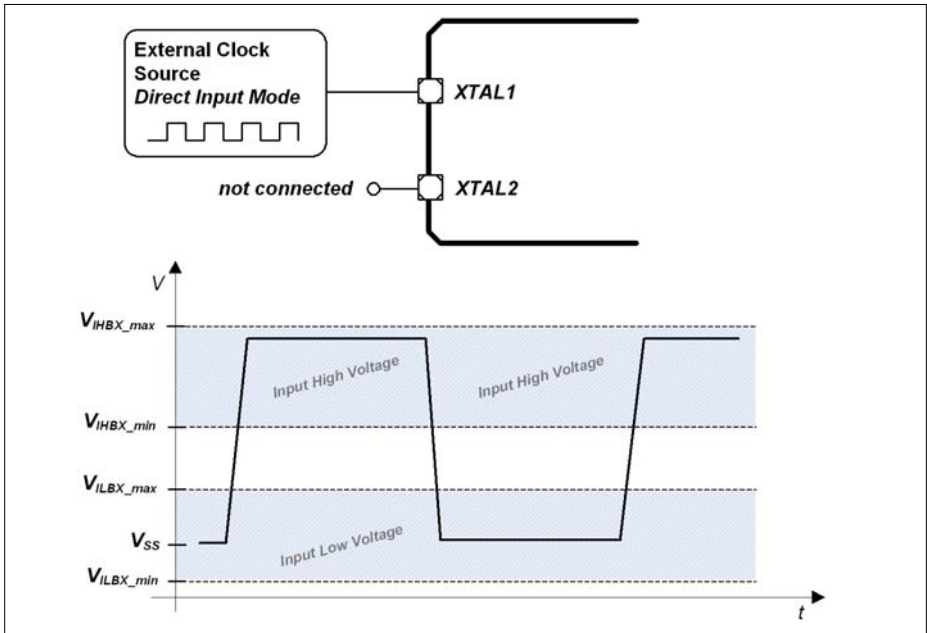

Figure 22 Oscillator in Direct Input Mode

Table 36 OSC_XTAL Parameters

Parameter	Symbol	Values			Unit	Note / Test Condition
		Min.	Typ.	Max.		
Input frequency	f_{OSC} SR	4	–	40	MHz	Direct Input Mode selected
		4	–	25	MHz	External Crystal Mode selected
Oscillator start-up time ¹⁾²⁾	t_{OSCS} CC	–	–	10	ms	
Input voltage at XTAL1	V_{IX} SR	-0.5	–	$V_{\text{DDP}} + 0.5$	V	
Input amplitude (peak-to-peak) at XTAL1 ²⁾³⁾	V_{PPX} SR	$0.4 \times V_{\text{DDP}}$	–	$V_{\text{DDP}} + 1.0$	V	
Input high voltage at XTAL1 ⁴⁾	V_{IHBX} SR	1.0	–	$V_{\text{DDP}} + 0.5$	V	
Input low voltage at XTAL1 ⁴⁾	V_{ILBX} SR	-0.5	–	0.4	V	
Input leakage current at XTAL1	I_{ILX1} CC	-100	–	100	nA	Oscillator power down $0 \text{ V} \leq V_{\text{IX}} \leq V_{\text{DDP}}$

1) t_{OSCS} is defined from the moment the oscillator is enabled with SCU_OSCHPCTRL.MODE until the oscillations reach an amplitude at XTAL1 of $0.4 \times V_{\text{DDP}}$.

2) The external oscillator circuitry must be optimized by the customer and checked for negative resistance and amplitude as recommended and specified by crystal suppliers.

3) If the shaper unit is enabled and not bypassed.

4) If the shaper unit is bypassed, dedicated DC-thresholds have to be met.

Table 37 RTC_XTAL Parameters

Parameter	Symbol	Values			Unit	Note / Test Condition
		Min.	Typ.	Max.		
Input frequency	f_{OSC} SR	–	32.768	–	kHz	
Oscillator start-up time ¹⁾²⁾³⁾	t_{OSCS} CC	–	–	5	s	
Input voltage at RTC_XTAL1	V_{IX} SR	-0.3	–	$V_{BAT} + 0.3$	V	
Input amplitude (peak-to-peak) at RTC_XTAL1 ²⁾⁴⁾	V_{PPX} SR	0.4	–	–	V	
Input high voltage at RTC_XTAL1 ⁵⁾	V_{IHBX} SR	$0.6 \times V_{BAT}$	–	$V_{BAT} + 0.3$	V	
Input low voltage at RTC_XTAL1 ⁵⁾	V_{ILBX} SR	-0.3	–	$0.36 \times V_{BAT}$	V	
Input Hysteresis for RTC_XTAL1 ³⁾⁶⁾	V_{HYSX} CC	$0.1 \times V_{BAT}$		–	V	$3.0 \text{ V} \leq V_{BAT} < 3.6 \text{ V}$
		$0.03 \times V_{BAT}$		–	V	$V_{BAT} < 3.0 \text{ V}$
Input leakage current at RTC_XTAL1	I_{ILX1} CC	-100	–	100	nA	Oscillator power down $0 \text{ V} \leq V_{IX} \leq V_{BAT}$

- 1) t_{OSCS} is defined from the moment the oscillator is enabled by the user with SCU_OSCULCTRL.MODE until the oscillations reach an amplitude at RTC_XTAL1 of 400 mV.
- 2) The external oscillator circuitry must be optimized by the customer and checked for negative resistance and amplitude as recommended and specified by crystal suppliers.
- 3) For a reliable start of the oscillation in crystal mode it is required that $V_{BAT} \geq 3.0 \text{ V}$. A running oscillation is maintained across the full V_{BAT} voltage range.
- 4) If the shaper unit is enabled and not bypassed.
- 5) If the shaper unit is bypassed, dedicated DC-thresholds have to be met.
- 6) Hysteresis is implemented to avoid metastable states and switching due to internal ground bounce. It can not be guaranteed that it suppresses switching due to external system noise.

3.2.10 Power Supply Current

The total power supply current defined below consists of a leakage and a switching component.

Application relevant values are typically lower than those given in the following tables, and depend on the customer's system operating conditions (e.g. thermal connection or used application configurations).

Note: These parameters are not subject to production test, but verified by design and/or characterization.

If not stated otherwise, the operating conditions for the parameters in the following table are:

$$V_{DDP} = 3.3 \text{ V}, T_A = 25 \text{ }^\circ\text{C}$$

Table 38 Power Supply Parameters

Parameter	Symbol	Values			Unit	Note / Test Condition
		Min.	Typ.	Max.		
Active supply current ¹⁾ Peripherals enabled Frequency: $f_{CPU} / f_{PERIPH} / f_{CCU}$ in MHz	I_{DDPA} CC	-	80	-	mA	80 / 80 / 80
		-	75	-		80 / 40 / 40
		-	73	-		40 / 40 / 80
		-	59	-		24 / 24 / 24
		-	50	-		1 / 1 / 1
Active supply current Code execution from RAM Flash in Sleep mode Frequency: $f_{CPU} / f_{PERIPH} / f_{CCU}$ in MHz	I_{DDPA} CC	-	24	-	mA	80 / 80 / 80
		-	19	-		80 / 40 / 40
Active supply current ²⁾ Peripherals disabled Frequency: f_{CPU} / f_{PERIPH} in MHz	I_{DDPA} CC	-	63	-	mA	80 / 80 / 80
		-	62	-		80 / 40 / 40
		-	60	-		40 / 40 / 80
		-	54	-		24 / 24 / 24
		-	50	-		1 / 1 / 1

Electrical Parameters
Table 38 Power Supply Parameters

Parameter	Symbol	Values			Unit	Note / Test Condition
		Min.	Typ.	Max.		
Sleep supply current ³⁾ Peripherals enabled Frequency: $f_{CPU} / f_{PERIPH} / f_{CCU}$ in MHz	I_{DDPS} CC	-	76	-	mA	80 / 80 / 80
		-	73	-		80 / 40 / 40
		-	70	-		40 / 40 / 80
		-	56	-		24 / 24 / 24
		-	47	-		1 / 1 / 1
		-	46	-		100 / 100 / 100
$f_{CPU} / f_{PERIPH} / f_{CCU}$ in kHz						
Sleep supply current ⁴⁾ Peripherals disabled Frequency: $f_{CPU} / f_{PERIPH} / f_{CCU}$ in MHz	I_{DDPS} CC	-	59	-	mA	80 / 80 / 80
		-	58	-		80 / 40 / 40
		-	57	-		40 / 40 / 80
		-	51	-		24 / 24 / 24
		-	46	-		1 / 1 / 1
		-	46	-		100 / 100 / 100
$f_{CPU} / f_{PERIPH} / f_{CCU}$ in kHz						
Deep Sleep supply current ⁵⁾ Flash in Sleep mode Frequency: $f_{CPU} / f_{PERIPH} / f_{CCU}$ in MHz	I_{DDPD} CC	-	6.9	-	mA	24 / 24 / 24
		-	4.3	-		4 / 4 / 4
		-	3.8	-		1 / 1 / 1
		-	4.5	-		100 / 100 / 100 ⁶⁾
$f_{CPU} / f_{PERIPH} / f_{CCU}$ in kHz						
Hibernate supply current RTC on ⁷⁾	I_{DDPH} CC	-	10.8	-	μ A	$V_{BAT} = 3.3$ V
		-	8.0	-		$V_{BAT} = 2.4$ V
		-	6.8	-		$V_{BAT} = 2.0$ V
Hibernate supply current RTC off ⁸⁾	I_{DDPH} CC	-	10.3	-	μ A	$V_{BAT} = 3.3$ V
		-	7.5	-		$V_{BAT} = 2.4$ V
		-	6.3	-		$V_{BAT} = 2.0$ V
Worst case active supply current ⁹⁾	I_{DDPA} CC	-	-	140 ¹⁰⁾	mA	$V_{DDP} = 3.6$ V, $T_J = 150$ °C
V_{DDA} power supply current	I_{DDA} CC	-	-	- ¹¹⁾	mA	
I_{DDP} current at PORST Low	I_{DDP_PORST} CC	-	-	24	mA	$V_{DDP} = 3.6$ V, $T_J = 150$ °C

Table 38 Power Supply Parameters

Parameter	Symbol	Values			Unit	Note / Test Condition
		Min.	Typ.	Max.		
Power Dissipation	P_{DISS} CC	–	–	1	W	$V_{DDP} = 3.6\text{ V}$, $T_J = 150\text{ °C}$
Wake-up time from Sleep to Active mode	t_{SSA} CC	–	6	–	cycles	
Wake-up time from Deep Sleep to Active mode		–	–	–	ms	Defined by the wake-up of the Flash module, see Section 3.2.11
Wake-up time from Hibernate mode		–	–	–	ms	Wake-up via power-on reset event, see Section 3.3.2

- 1) CPU executing code from Flash, all peripherals idle.
- 2) CPU executing code from Flash. USB and CCU clock off.
- 3) CPU in sleep, all peripherals idle, Flash in Active mode.
- 4) CPU in sleep, Flash in Active mode.
- 5) CPU in sleep, peripherals disabled, after wake-up code execution from RAM.
- 6) To wake-up the Flash from its Sleep mode, $f_{CPU} \geq 1\text{ MHz}$ is required.
- 7) OSC_ULP operating with external crystal on RTC_XTAL
- 8) OSC_ULP off, Hibernate domain operating with OSC_SI clock
- 9) Test Power Loop: $f_{SYS} = 80\text{ MHz}$, CPU executing benchmark code from Flash, all CCUs in 100kHz timer mode, all ADC groups in continuous conversion mode, USICs as SPI in internal loop-back mode, CAN in 500kHz internal loop-back mode, interrupt triggered DMA block transfers to parity protected RAMs and FCE, DTS measurements and FPU calculations.
The power consumption of each customer application will most probably be lower than this value, but must be evaluated separately.
- 10) I_{DDP} decreases typically by 3.5 mA when f_{SYS} decreases by 10 MHz, at constant T_J
- 11) Sum of currents of all active converters (ADC and DAC)

Peripheral Idle Currents

Test conditions:

- f_{sys} and derived clocks at 80 MHz
- $V_{DDP} = 3.3\text{ V}$, $T_a = 25\text{ °C}$
- all peripherals are held in reset (see the PRSTAT registers in the Reset Control Unit of the SCU)
- the peripheral clocks are disabled (see CGATSTAT registers in the Clock Control Unit of the SCU)
- no I/O activity
- the given values are a result of differential measurements with asserted and deasserted peripheral reset and enabled clock of the peripheral under test

The tested peripheral is left in the state after the peripheral reset is deasserted, no further initialisation or configuration is done. E.g. no timer is running in the CCUs, no communication active in the USICs, etc.

Table 39 Peripheral Idle Currents

Parameter	Symbol	Values			Unit	Note / Test Condition
		Min.	Typ.	Max.		
PORTS USB FCE WDT POSIFx ¹⁾	$I_{PER\ CC}$	–	≤ 0.3	–	mA	
MultICAN ERU LEDTSCU0 CCU4x ¹⁾ CCU8x ¹⁾		–	≤ 1.0	–		
DAC (digital) ²⁾		–	1.3	–		
USICx		–	3.0	–		
VADC (digital) ²⁾		–	4.5	–		
DMAx		–	6.0	–		

1) Enabling the f_{CCU} clock for the POSIFx/CCU4x/CCU8x modules adds approximately $I_{PER} = 1.8\text{ mA}$, disregarding which and how many of those peripherals are enabled.

2) The current consumption of the analog components are given in the dedicated Data Sheet sections of the respective peripheral.

3.2.11 Flash Memory Parameters

Note: These parameters are not subject to production test, but verified by design and/or characterization.

Table 40 Flash Memory Parameters

Parameter	Symbol	Values			Unit	Note / Test Condition
		Min.	Typ.	Max.		
Erase Time per 256 Kbyte Sector	t_{ERP} CC	–	5	5.5	s	
Erase Time per 64 Kbyte Sector	t_{ERP} CC	–	1.2	1.4	s	
Erase Time per 16 Kbyte Logical Sector	t_{ERP} CC	–	0.3	0.4	s	
Program time per page ¹⁾	t_{PRP} CC	–	5.5	11	ms	
Erase suspend delay	t_{FL_ErSusp} CC	–	–	15	ms	
Wait time after margin change	$t_{FL_MarginDel}$ CC	10	–	–	μs	
Wake-up time	t_{WU} CC	–	–	270	μs	
Read access time	t_a CC	20	–	–	ns	For operation with $1/f_{CPU} < t_a$ wait states must be configured ²⁾
Data Retention Time, Physical Sector ³⁾⁴⁾	t_{RET} CC	20	–	–	years	Max. 1000 erase/program cycles
Data Retention Time, Logical Sector ³⁾⁴⁾	t_{RETL} CC	20	–	–	years	Max. 100 erase/program cycles

Table 40 Flash Memory Parameters

Parameter	Symbol	Values			Unit	Note / Test Condition
		Min.	Typ.	Max.		
Data Retention Time, User Configuration Block (UCB) ³⁾⁴⁾	t_{RTU} CC	20	–	–	years	Max. 4 erase/program cycles per UCB
Endurance on 64 Kbyte Physical Sector PS4	N_{EPS4} CC	10000	–	–	cycles	BA-marking devices only! Cycling distributed over life time ⁵⁾

- 1) In case the Program Verify feature detects weak bits, these bits will be programmed once more. The reprogramming takes an additional time of 5.5 ms.
- 2) The following formula applies to the wait state configuration: $FCON.WSPFLASH \times (1 / f_{CPU}) \geq t_a$.
- 3) Storage and inactive time included.
- 4) Values given are valid for an average weighted junction temperature of $T_J = 110^\circ\text{C}$.
- 5) Only valid with robust EEPROM emulation algorithm, equally cycling the logical sectors. For more details see the Reference Manual.

3.3 AC Parameters

3.3.1 Testing Waveforms

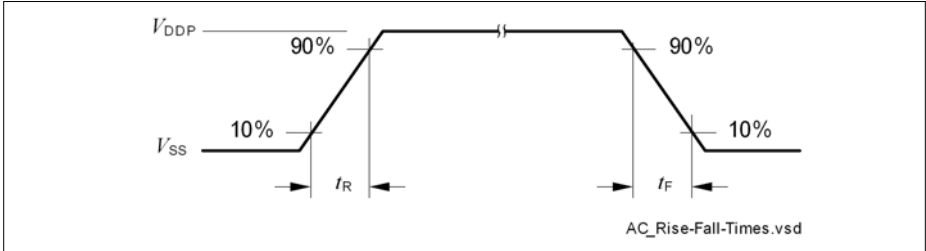

Figure 23 Rise/Fall Time Parameters

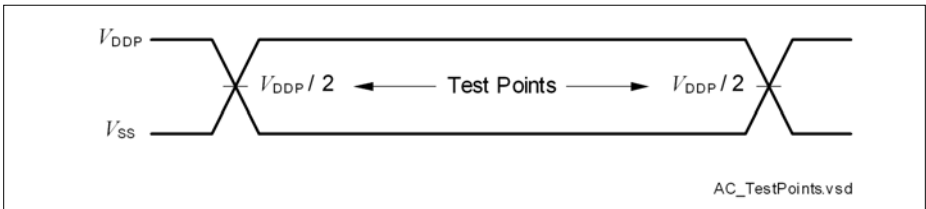

Figure 24 Testing Waveform, Output Delay

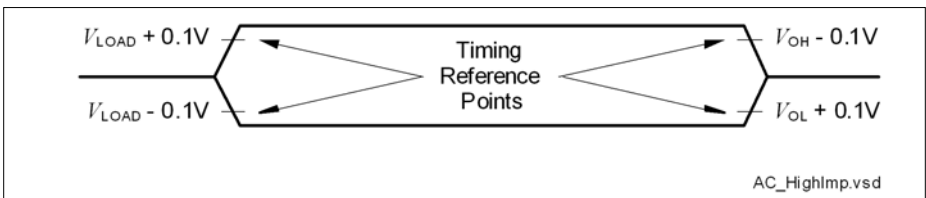

Figure 25 Testing Waveform, Output High Impedance

3.3.2 Power-Up and Supply Monitoring

$\overline{\text{PORST}}$ is always asserted when V_{DDP} and/or V_{DDC} violate the respective thresholds.

Note: These parameters are not subject to production test, but verified by design and/or characterization.

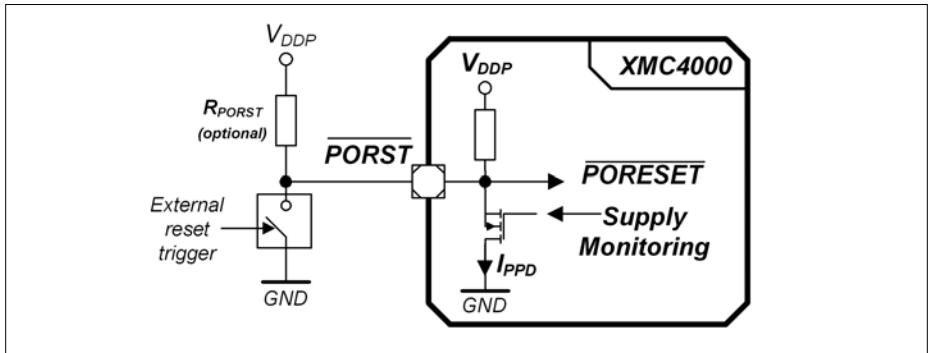

Figure 26 $\overline{\text{PORST}}$ Circuit

Table 41 Supply Monitoring Parameters

Parameter	Symbol	Values			Unit	Note / Test Condition
		Min.	Typ.	Max.		
Digital supply voltage reset threshold	V_{POR} CC	2.79 ¹⁾	–	3.05 ²⁾	V	3)
Core supply voltage reset threshold	V_{PV} CC	–	–	1.17	V	
V_{DDP} voltage to ensure defined pad states	V_{DDPPA} CC	–	1.0	–	V	
$\overline{\text{PORST}}$ rise time	t_{PR} SR	–	–	2	μs	
Startup time from power-on reset with code execution from Flash	t_{SSW} CC	–	2.5	3.5	ms	Time to the first user code instruction
V_{DDC} ramp up time	t_{VCR} CC	–	550	–	μs	Ramp up after power-on or after a reset triggered by a violation of V_{POR} or V_{PV}

1) Minimum threshold for reset assertion.

- 2) Maximum threshold for reset deassertion.
- 3) The V_{DDP} monitoring has a typical hysteresis of $V_{PORHYS} = 180\text{ mV}$.

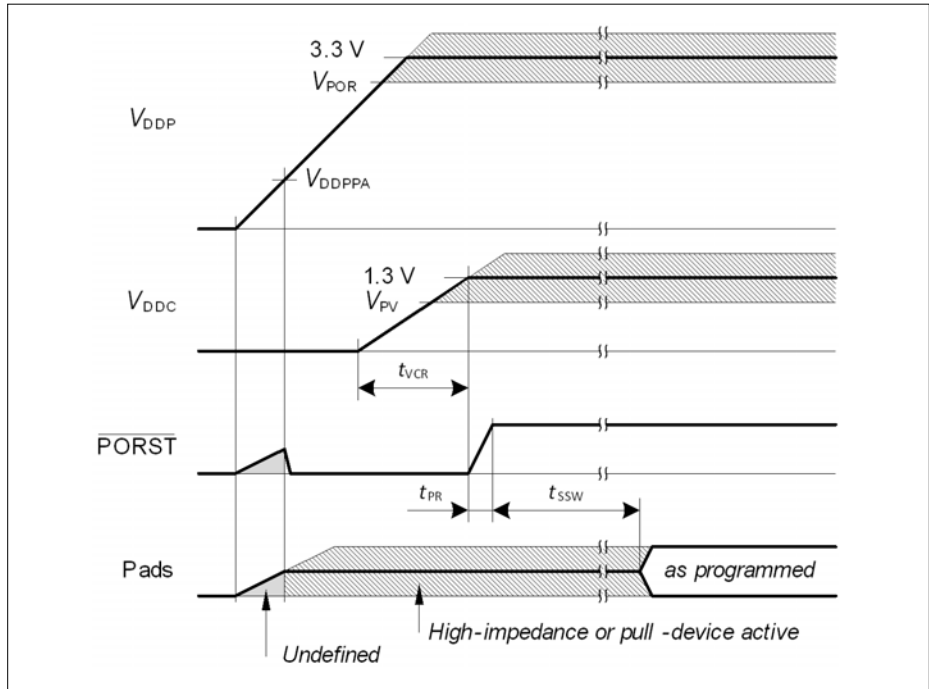

Figure 27 Power-Up Behavior

3.3.3 Power Sequencing

While starting up and shutting down as well as when switching power modes of the system it is important to limit the current load steps. A typical cause for such load steps is changing the CPU frequency f_{CPU} . Load steps exceeding the below defined values may cause a power on reset triggered by the supply monitor.

Note: These parameters are not subject to production test, but verified by design and/or characterization.

Table 42 Power Sequencing Parameters

Parameter	Symbol	Values			Unit	Note / Test Condition
		Min.	Typ.	Max.		
Positive Load Step Current	ΔI_{PLS} SR	-	-	50	mA	Load increase on V_{DDP} $\Delta t \leq 10$ ns
Negative Load Step Current	ΔI_{NLS} SR	-	-	150	mA	Load decrease on V_{DDP} $\Delta t \leq 10$ ns
V_{DDC} Voltage Over- / Undershoot from Load Step	ΔV_{LS} CC	-	-	± 100	mV	For maximum positive or negative load step
Positive Load Step Settling Time	t_{PLSS} SR	50	-	-	μ s	
Negative Load Step Settling Time	t_{NLSS} SR	100	-	-	μ s	
External Buffer Capacitor on V_{DDC}	C_{EXT} SR	3	4.7	6	μ F	In addition $C = 100$ nF capacitor on each V_{DDC} pin

Positive Load Step Examples

System assumptions:

$f_{CPU} = f_{SYS}$, target frequency $f_{CPU} = 80$ MHz, main PLL $f_{VCO} = 480$ MHz, stepping done by K2 divider, t_{PLSS} between individual steps:

24 MHz - 48 MHz - 80 MHz (K2 steps 20 - 10 - 6)

24 MHz - 60 MHz - 80 MHz (K2 steps 20 - 8 - 6)

3.3.4 Phase Locked Loop (PLL) Characteristics

Main and USB PLL

Table 43 PLL Parameters

Parameter	Symbol	Values			Unit	Note / Test Condition
		Min.	Typ.	Max.		
Accumulated Jitter	D_P CC	–	–	±5	ns	accumulated over 300 cycles $f_{SYS} = 80$ MHz
Duty Cycle ¹⁾	D_{DC} CC	46	50	54	%	Low pulse to total period, assuming an ideal input clock source
PLL base frequency	$f_{PLLBASE}$ CC	30	–	140	MHz	
VCO input frequency	f_{REF} CC	4	–	16	MHz	
VCO frequency range	f_{VCO} CC	260	–	520	MHz	
PLL lock-in time	t_L CC	–	–	400	μs	

1) 50% for even K2 divider values, $50 \pm (10/K2)$ for odd K2 divider values.

3.3.5 Internal Clock Source Characteristics

Fast Internal Clock Source

Table 44 Fast Internal Clock Parameters

Parameter	Symbol	Values			Unit	Note / Test Condition
		Min.	Typ.	Max.		
Nominal frequency	$f_{\text{OFINC CC}}$	–	36.5	–	MHz	not calibrated
		–	24	–	MHz	calibrated
Accuracy	$\Delta f_{\text{OFI CC}}$	-0.5	–	0.5	%	automatic calibration ¹⁾²⁾
		-15	–	15	%	factory calibration, $V_{\text{DDP}} = 3.3 \text{ V}$
		-25	–	25	%	no calibration, $V_{\text{DDP}} = 3.3 \text{ V}$
		-7	–	7	%	Variation over voltage range ³⁾ $3.13 \text{ V} \leq V_{\text{DDP}} \leq 3.63 \text{ V}$
Start-up time	$t_{\text{OFIS CC}}$	–	50	–	μs	

1) Error in addition to the accuracy of the reference clock.

2) Automatic calibration compensates variations of the temperature and in the V_{DDP} supply voltage.

3) Deviations from the nominal V_{DDP} voltage induce an additional error to the uncalibrated and/or factory calibrated oscillator frequency.

Slow Internal Clock Source
Table 45 Slow Internal Clock Parameters

Parameter	Symbol	Values			Unit	Note / Test Condition
		Min.	Typ.	Max.		
Nominal frequency	f_{OSI} CC	–	32.768	–	kHz	
Accuracy	Δf_{OSI} CC	-4	–	4	%	$V_{BAT} = \text{const.}$ $0\text{ }^{\circ}\text{C} \leq T_A \leq 85\text{ }^{\circ}\text{C}$
		-5	–	5	%	$V_{BAT} = \text{const.}$ $T_A < 0\text{ }^{\circ}\text{C}$ or $T_A > 85\text{ }^{\circ}\text{C}$
		-5	–	5	%	$2.4\text{ V} \leq V_{BAT}$, $T_A = 25\text{ }^{\circ}\text{C}$
		-10	–	10	%	$1.95\text{ V} \leq V_{BAT} < 2.4\text{ V}$, $T_A = 25\text{ }^{\circ}\text{C}$
Start-up time	t_{OSIS} CC	–	50	–	μs	

3.3.6 JTAG Interface Timing

The following parameters are applicable for communication through the JTAG debug interface. The JTAG module is fully compliant with IEEE1149.1-2000.

Note: These parameters are not subject to production test, but verified by design and/or characterization.

Note: Operating conditions apply.

Table 46 JTAG Interface Timing Parameters

Parameter	Symbol		Values			Unit	Note / Test Condition
			Min.	Typ.	Max.		
TCK clock period	t_1	SR	30	–	–	ns	For $C_L = 20$ pF on TDO
TCK clock period	t_1	SR	40	–	–	ns	For $C_L = 50$ pF on TDO
TCK high time	t_2	SR	10	–	–	ns	
TCK low time	t_3	SR	10	–	–	ns	
TCK clock rise time	t_4	SR	–	–	4	ns	
TCK clock fall time	t_5	SR	–	–	4	ns	
TDI/TMS setup to TCK rising edge	t_6	SR	6	–	–	ns	
TDI/TMS hold after TCK rising edge	t_7	SR	6	–	–	ns	
TDO valid after TCK falling edge ¹⁾ (propagation delay)	t_8	CC	–	–	17	ns	$C_L = 50$ pF
			3	–	–	ns	$C_L = 20$ pF
TDO hold after TCK falling edge ¹⁾	t_{18}	CC	2	–	–	ns	
TDO high imped. to valid from TCK falling edge ¹⁾²⁾	t_9	CC	–	–	14	ns	$C_L = 50$ pF
TDO valid to high imped. from TCK falling edge ¹⁾	t_{10}	CC	–	–	13.5	ns	$C_L = 50$ pF

1) The falling edge on TCK is used to generate the TDO timing.

2) The setup time for TDO is given implicitly by the TCK cycle time.

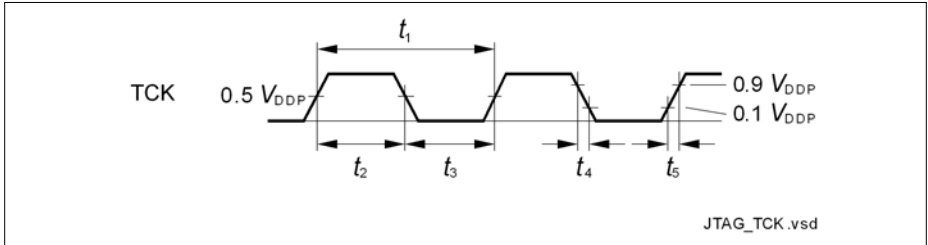

Figure 28 Test Clock Timing (TCK)

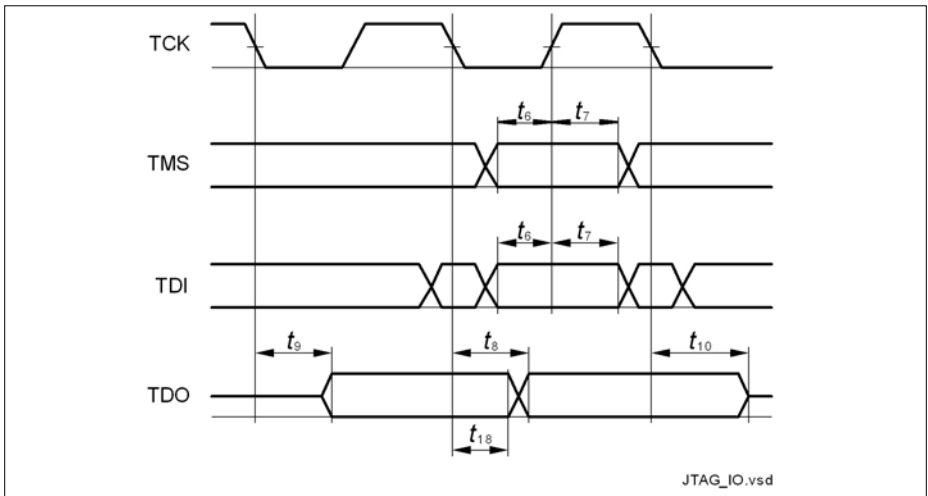

Figure 29 JTAG Timing

3.3.7 Serial Wire Debug Port (SW-DP) Timing

The following parameters are applicable for communication through the SW-DP interface.

Note: These parameters are not subject to production test, but verified by design and/or characterization.

Note: Operating conditions apply.

Table 47 SWD Interface Timing Parameters (Operating Conditions apply)

Parameter	Symbol		Values			Unit	Note / Test Condition
			Min.	Typ.	Max.		
SWDCLK clock period	t_{SC}	SR	25	–	–	ns	$C_L = 30$ pF
			40	–	–	ns	$C_L = 50$ pF
SWDCLK high time	t_1	SR	10	–	500000	ns	
SWDCLK low time	t_2	SR	10	–	500000	ns	
SWDIO input setup to SWDCLK rising edge	t_3	SR	6	–	–	ns	
SWDIO input hold after SWDCLK rising edge	t_4	SR	6	–	–	ns	
SWDIO output valid time after SWDCLK rising edge	t_5	CC	–	–	17	ns	$C_L = 50$ pF
			–	–	13	ns	$C_L = 30$ pF
SWDIO output hold time from SWDCLK rising edge	t_6	CC	3	–	–	ns	

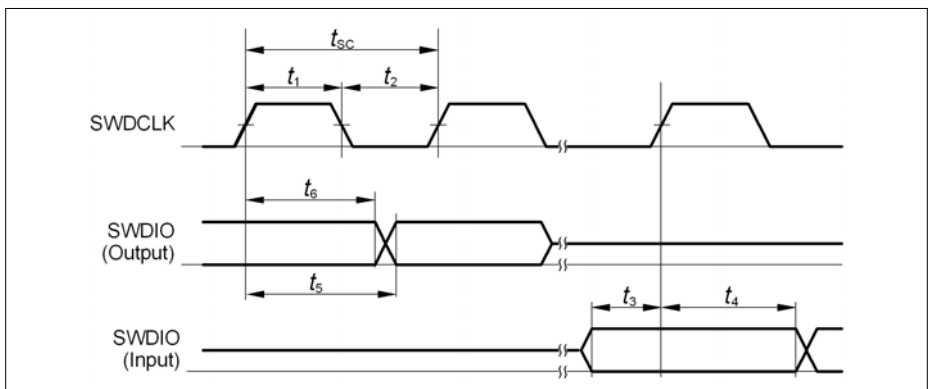

Figure 30 SWD Timing

3.3.8 Peripheral Timing

Note: These parameters are not subject to production test, but verified by design and/or characterization.

Note: Operating conditions apply.

3.3.8.1 Synchronous Serial Interface (USIC SSC) Timing

The following parameters are applicable for a USIC channel operated in SSC mode.

Note: Operating Conditions apply.

Table 48 USIC SSC Master Mode Timing

Parameter	Symbol	Values			Unit	Note / Test Condition
		Min.	Typ.	Max.		
SCLKOUT master clock period	t_{CLK} CC	40	–	–	ns	
Slave select output SELO active to first SCLKOUT transmit edge	t_1 CC	$t_{SYS} - 6.5^{1)}$	–	–	ns	
Slave select output SELO inactive after last SCLKOUT receive edge	t_2 CC	$t_{SYS} - 8.5^{1)}$	–	–	ns	
Data output DOUT[3:0] valid time	t_3 CC	-6	–	8	ns	
Receive data input DX0/DX[5:3] setup time to SCLKOUT receive edge	t_4 SR	23	–	–	ns	
Data input DX0/DX[5:3] hold time from SCLKOUT receive edge	t_5 SR	1	–	–	ns	

1) $t_{SYS} = 1 / f_{PB}$

Table 49 USIC SSC Slave Mode Timing

Parameter	Symbol		Values			Unit	Note / Test Condition
			Min.	Typ.	Max.		
DX1 slave clock period	t_{CLK}	SR	66.6	–	–	ns	
Select input DX2 setup to first clock input DX1 transmit edge ¹⁾	t_{10}	SR	3	–	–	ns	
Select input DX2 hold after last clock input DX1 receive edge ¹⁾	t_{11}	SR	4	–	–	ns	
Receive data input DX0/DX[5:3] setup time to shift clock receive edge ¹⁾	t_{12}	SR	6	–	–	ns	
Data input DX0/DX[5:3] hold time from clock input DX1 receive edge ¹⁾	t_{13}	SR	4	–	–	ns	
Data output DOUT[3:0] valid time	t_{14}	CC	0	–	24	ns	

1) These input timing are valid for asynchronous input signal handling of slave select input, shift clock input, and receive data input (bits DXnCR.DSEN = 0).

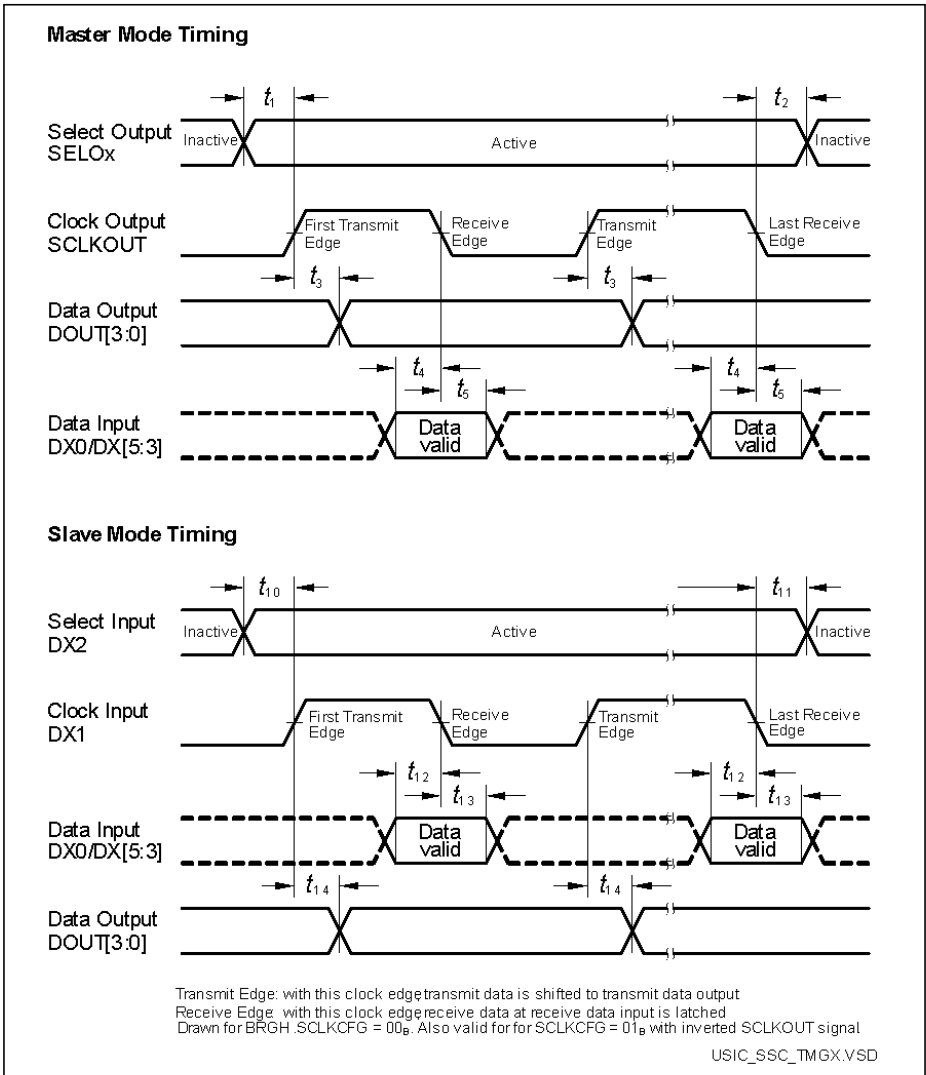

Figure 31 USIC - SSC Master/Slave Mode Timing

Note: This timing diagram shows a standard configuration, for which the slave select signal is low-active, and the serial clock signal is not shifted and not inverted.

3.3.8.2 Inter-IC (IIC) Interface Timing

The following parameters are applicable for a USIC channel operated in IIC mode.

Note: Operating Conditions apply.

Table 50 USIC IIC Standard Mode Timing¹⁾

Parameter	Symbol	Values			Unit	Note / Test Condition
		Min.	Typ.	Max.		
Fall time of both SDA and SCL	t_1 CC/SR	-	-	300	ns	
Rise time of both SDA and SCL	t_2 CC/SR	-	-	1000	ns	
Data hold time	t_3 CC/SR	0	-	-	µs	
Data set-up time	t_4 CC/SR	250	-	-	ns	
LOW period of SCL clock	t_5 CC/SR	4.7	-	-	µs	
HIGH period of SCL clock	t_6 CC/SR	4.0	-	-	µs	
Hold time for (repeated) START condition	t_7 CC/SR	4.0	-	-	µs	
Set-up time for repeated START condition	t_8 CC/SR	4.7	-	-	µs	
Set-up time for STOP condition	t_9 CC/SR	4.0	-	-	µs	
Bus free time between a STOP and START condition	t_{10} CC/SR	4.7	-	-	µs	
Capacitive load for each bus line	C_b SR	-	-	400	pF	

1) Due to the wired-AND configuration of an IIC bus system, the port drivers of the SCL and SDA signal lines need to operate in open-drain mode. The high level on these lines must be held by an external pull-up device, approximately 10 kOhm for operation at 100 kbit/s, approximately 2 kOhm for operation at 400 kbit/s.

Table 51 USIC IIC Fast Mode Timing¹⁾

Parameter	Symbol	Values			Unit	Note / Test Condition
		Min.	Typ.	Max.		
Fall time of both SDA and SCL	t_1 CC/SR	20 + 0.1 * C_b 2)	-	300	ns	
Rise time of both SDA and SCL	t_2 CC/SR	20 + 0.1 * C_b 2)	-	300	ns	
Data hold time	t_3 CC/SR	0	-	-	μs	
Data set-up time	t_4 CC/SR	100	-	-	ns	
LOW period of SCL clock	t_5 CC/SR	1.3	-	-	μs	
HIGH period of SCL clock	t_6 CC/SR	0.6	-	-	μs	
Hold time for (repeated) START condition	t_7 CC/SR	0.6	-	-	μs	
Set-up time for repeated START condition	t_8 CC/SR	0.6	-	-	μs	
Set-up time for STOP condition	t_9 CC/SR	0.6	-	-	μs	
Bus free time between a STOP and START condition	t_{10} CC/SR	1.3	-	-	μs	
Capacitive load for each bus line	C_b SR	-	-	400	pF	

1) Due to the wired-AND configuration of an IIC bus system, the port drivers of the SCL and SDA signal lines need to operate in open-drain mode. The high level on these lines must be held by an external pull-up device, approximately 10 kOhm for operation at 100 kbit/s, approximately 2 kOhm for operation at 400 kbit/s.

2) C_b refers to the total capacitance of one bus line in pF.

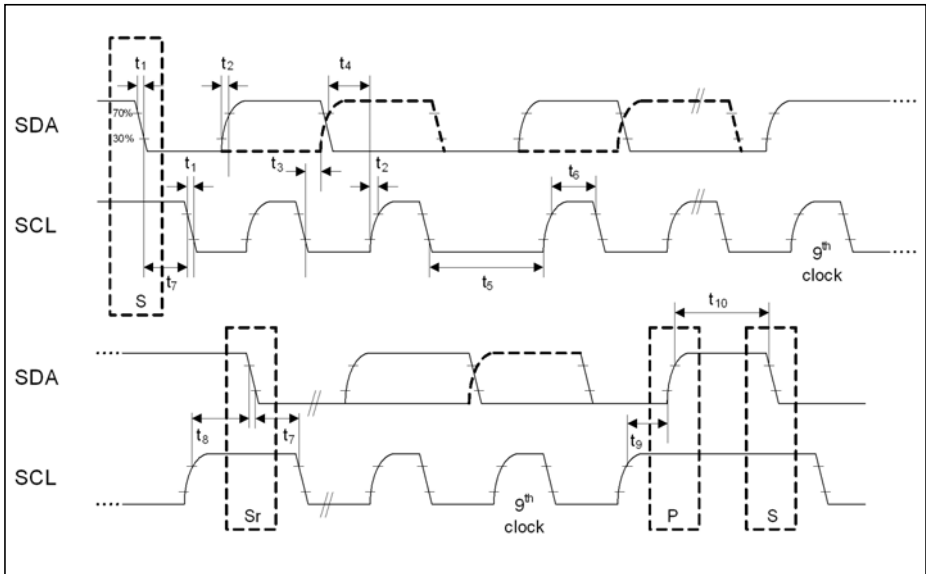

Figure 32 USIC IIC Stand and Fast Mode Timing

3.3.8.3 Inter-IC Sound (IIS) Interface Timing

The following parameters are applicable for a USIC channel operated in IIS mode.

Note: Operating Conditions apply.

Table 52 USIC IIS Master Transmitter Timing

Parameter	Symbol	Values			Unit	Note / Test Condition
		Min.	Typ.	Max.		
Clock period	t_1 CC	33.3	–	–	ns	
Clock high time	t_2 CC	0.35 x t_{1min}	–	–	ns	
Clock low time	t_3 CC	0.35 x t_{1min}	–	–	ns	
Hold time	t_4 CC	0	–	–	ns	
Clock rise time	t_5 CC	–	–	0.15 x t_{1min}	ns	

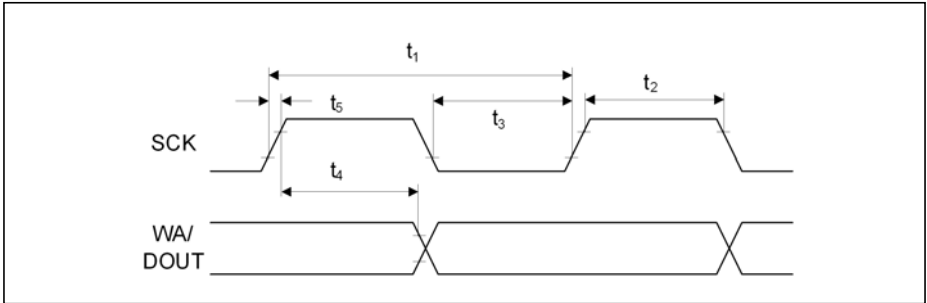

Figure 33 USIC IIS Master Transmitter Timing

Table 53 USIC IIS Slave Receiver Timing

Parameter	Symbol	Values			Unit	Note / Test Condition
		Min.	Typ.	Max.		
Clock period	t_6 SR	66.6	–	–	ns	
Clock high time	t_7 SR	$0.35 \times t_{6min}$	–	–	ns	
Clock low time	t_8 SR	$0.35 \times t_{6min}$	–	–	ns	
Set-up time	t_9 SR	$0.2 \times t_{6min}$	–	–	ns	
Hold time	t_{10} SR	0	–	–	ns	

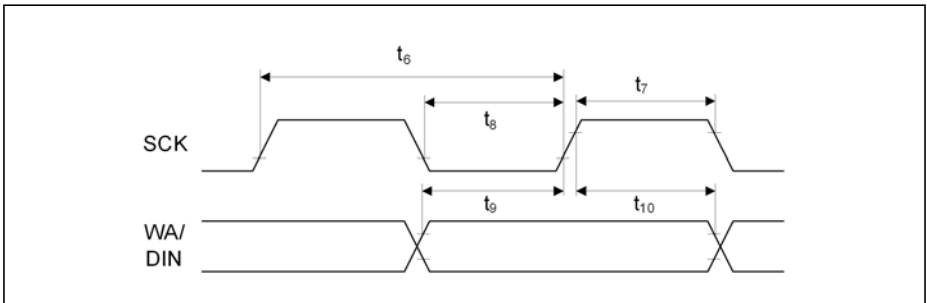

Figure 34 USIC IIS Slave Receiver Timing

3.3.9 USB Interface Characteristics

The Universal Serial Bus (USB) Interface is compliant to the USB Rev. 2.0 Specification. High-Speed Mode is not supported.

Note: These parameters are not subject to production test, but verified by design and/or characterization.

Table 54 USB Timing Parameters (operating conditions apply)

Parameter	Symbol		Values			Unit	Note / Test Condition
			Min.	Typ.	Max.		
Rise time	t_R	CC	4	–	20	ns	$C_L = 50$ pF
Fall time	t_F	CC	4	–	20	ns	$C_L = 50$ pF
Rise/Fall time matching	t_R/t_F	CC	90	–	111.11	%	$C_L = 50$ pF
Crossover voltage	V_{CRS}	CC	1.3	–	2.0	V	$C_L = 50$ pF

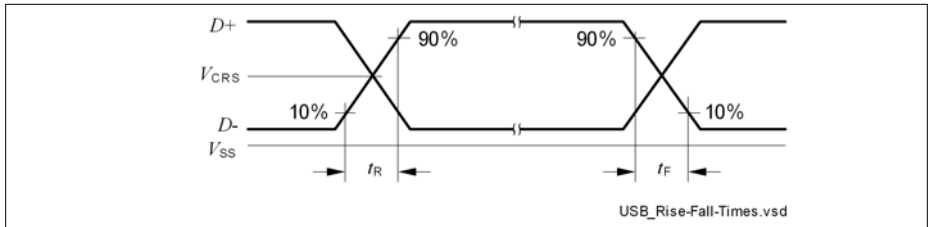

Figure 35 USB Signal Timing

4 Package and Reliability

The XMC4[12]00 is a member of the XMC4000 Family of microcontrollers. It is also compatible to a certain extent with members of similar families or subfamilies.

Each package is optimized for the device it houses. Therefore, there may be slight differences between packages of the same pin-count but for different device types. In particular, the size of the Exposed Die Pad may vary.

If different device types are considered or planned for an application, it must be ensured that the board layout fits all packages under consideration.

4.1 Package Parameters

Table 55 provides the thermal characteristics of the packages used in XMC4[12]00. The availability of different packages for different markings is listed in **Table 2**.

Table 55 Thermal Characteristics of the Packages

Parameter	Symbol	Limit Values		Unit	Package Types
		Min.	Max.		
Exposed Die Pad Dimensions	Ex × Ey CC	-	5.7 × 5.7	mm	PG-TQFP-64-19 PG-TQFP-64-21
		-	5.2 × 5.2	mm	PG-VQFN-48-71
Thermal resistance Junction-Ambient	$R_{\Theta JA}$ CC	-	23.4	K/W	PG-TQFP-64-19 ¹⁾ PG-TQFP-64-21 ¹⁾
		-	34.8	K/W	PG-VQFN-48-71 ¹⁾
Package thickness 1.0 ^{±0.05} mm	-	-	1.2 Max	mm	PG-TQFP-64-19 PG-TQFP-64-21

1) Device mounted on a 4-layer JEDEC board (JESD 51-7) with thermal vias; exposed pad soldered.

Note: For electrical reasons, it is required to connect the exposed pad to the board ground V_{SS} , independent of EMC and thermal requirements.

4.1.1 Thermal Considerations

When operating the XMC4[12]00 in a system, the total heat generated in the chip must be dissipated to the ambient environment to prevent overheating and the resulting thermal damage.

The maximum heat that can be dissipated depends on the package and its integration into the target board. The “Thermal resistance $R_{\Theta JA}$ ” quantifies these parameters. The power dissipation must be limited so that the average junction temperature does not exceed 150 °C.

The difference between junction temperature and ambient temperature is determined by $\Delta T = (P_{INT} + P_{IOSTAT} + P_{IODYN}) \times R_{\Theta JA}$

The internal power consumption is defined as

$$P_{INT} = V_{DDP} \times I_{DDP} \text{ (switching current and leakage current).}$$

The static external power consumption caused by the output drivers is defined as

$$P_{IOSTAT} = \Sigma((V_{DDP} - V_{OH}) \times I_{OH}) + \Sigma(V_{OL} \times I_{OL})$$

The dynamic external power consumption caused by the output drivers (P_{IODYN}) depends on the capacitive load connected to the respective pins and their switching frequencies.

If the total power dissipation for a given system configuration exceeds the defined limit, countermeasures must be taken to ensure proper system operation:

- Reduce V_{DDP} , if possible in the system
- Reduce the system frequency
- Reduce the number of output pins
- Reduce the load on active output drivers

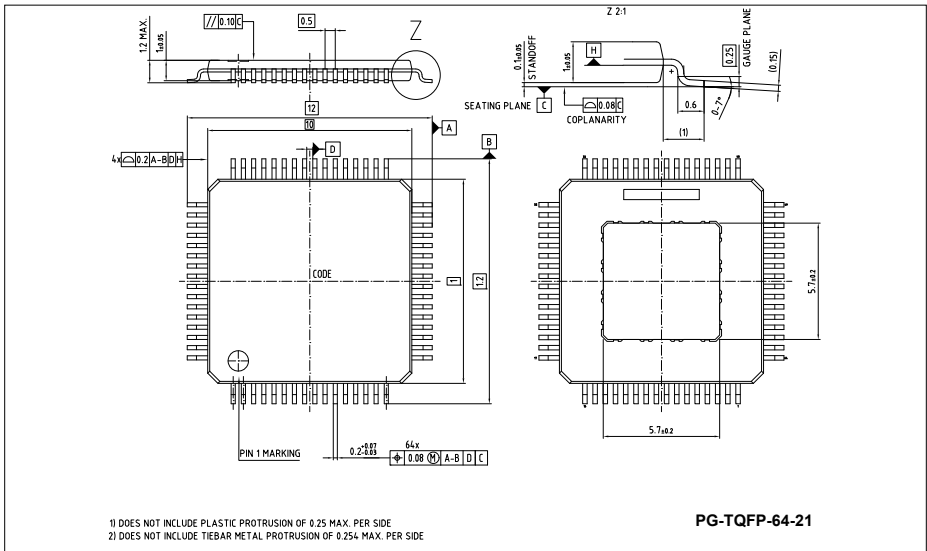

Figure 37 PG-TQFP-64-21 (Plastic Green Thin Profile Quad Flat Package)

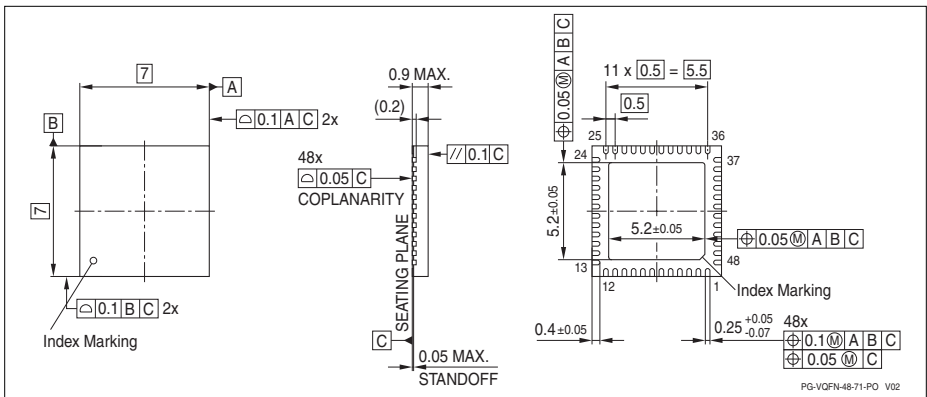

Figure 38 PG-VQFN-48-71 (Plastic Green Very Thin Profile Flat Non Ledged Package)

All dimensions in mm.

You can find complete information about Infineon packages, packing and marking in our Infineon Internet Page “Packages”: <http://www.infineon.com/packages>

5 Quality Declarations

The qualification of the XMC4[12]00 is executed according to the JEDEC standard JESD47H.

Note: For automotive applications refer to the Infineon automotive microcontrollers.

Table 56 Quality Parameters



Parameter	Symbol	Values			Unit	Note / Test Condition
		Min.	Typ.	Max.		
Operation lifetime	t_{OP} CC	20	–	–	a	$T_J \leq 109^\circ\text{C}$, device permanent on
ESD susceptibility according to Human Body Model (HBM)	V_{HBM} SR	–	–	2 000	V	EIA/JESD22-A114-B
ESD susceptibility according to Charged Device Model (CDM)	V_{CDM} SR	–	–	500	V	Conforming to JESD22-C101-C
Moisture sensitivity level	MSL CC	–	–	3	–	JEDEC J-STD-020D
Soldering temperature	T_{SDR} SR	–	–	260	$^\circ\text{C}$	Profile according to JEDEC J-STD-020D

www.infineon.com





Published by Infineon Technologies AG

Looking for pricing, stock, or lifecycle information?

Click below to explore more details on WIN SOURCE:

-  [View XMC4100F64K128BAXQMA1 on WIN SOURCE](#)
-  [Infineon Technologies](#) Information

Optimize Your Supply Chain with WIN SOURCE Solutions

-  Global Sourcing Solution
-  Obsolete Management
-  Cost Control Management
-  Shortage Management
-  Alternative Solution
-  Excess Inventory Management