



**THE DATASHEET OF
S12M15600B**



S12M15600B(LS)

SENSITIVE GATE SILICON CONTROLLED RECTIFIERS REVERSE BLOCKING THYRISTORS

SCRs 12 AMPERES RMA 600 VOLTS

FEATURES

- Blocking Voltage to 600 Volts
- On-State Current Rating of 12 Amperes RMS at 80°C
- Rugged, Economical TO-220AB Package
- Glass Passivated Junctions for Reliability and Uniformity
- Minimum and Maximum Values of IGT, VGT and IH Specified for Ease of Design
- High Immunity to dv/dt – 100V/ms Minimum at 125°C
- **Lead-Free Finish; RoHS Compliant (Notes 1 & 2)**
- **Halogen and Antimony Free. "Green" Device (Note 3)**

MECHANICAL DATA

- Package: TO-220AB
- Package Material: Molded Plastic
- Weight: 0.07 ounces, 2.0 grams

TO-220AB

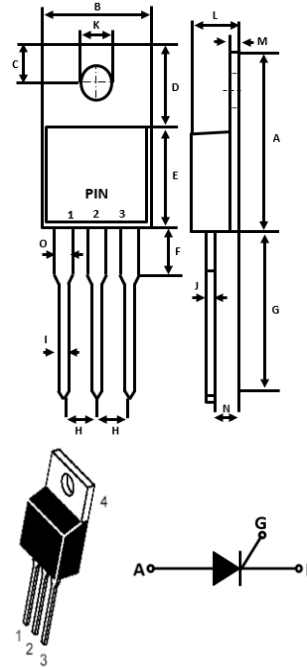

TO-220AB		
Dim.	Min.	Max.
A	14.22	15.88
B	9.65	10.67
C	2.54	3.43
D	5.84	6.86
E	8.26	9.28
F	-	6.35
G	12.70	14.73
H	2.29	2.79
I	0.51	1.14
J	0.40	0.67
K	3.35 ϕ	4.09 ϕ
L	3.56	4.83
M	1.14	1.40
N	2.03	2.92
O	1.17	1.37

All Dimensions in millimeter

PIN ASSIGNMENT	
1	Cathode
2	Anode
3	Gate
4	Anode

MAXIMUM RATINGS AND ELECTRICAL CHARACTERISTICS

Ratings at 25°C ambient temperature unless otherwise specified.

CHARACTERISTICS	SYMBOL	VALUE	UNIT
Peak Repetitive Off-State Voltage ($T_J = -40^\circ\text{C}$ to 125°C , Sine Wave, 50Hz to 60Hz; Gate Open)	V_{DRM} V_{RRM}	600	V
On-State RMS Current (180° Conduction Angles, $T_C = 80^\circ\text{C}$)	$I_{T(RMS)}$	12	A
Peak Non-Repetitive Surge Current (1/2 Cycle, Sine Wave, 60Hz, $T_J = 25^\circ\text{C}$) (1/2 Cycle, Sine Wave, 50Hz, $T_J = 25^\circ\text{C}$)	I_{TSM}	125 120	A
Circuit Fusing Consideration ($t = 8.3\text{ms}$) ($t = 10\text{ms}$)	I^2t	64 72	A ² s
Forward Peak Gate Power (Pulse Width $\leq 1.0\mu\text{s}$, $T_J = 80^\circ\text{C}$)	P_{GM}	5.0	W
Forward Average Gate Power ($t = 8.3\text{ms}$, $T_C = 80^\circ\text{C}$)	$P_{G(AV)}$	0.5	W
Forward Peak Gate Current (Pulse Width $\leq 1.0\mu\text{s}$, $T_C = 80^\circ\text{C}$)	I_{GM}	2.0	A
Operating Temperature Range	T_J	-40 to +125	°C
Storage Temperature Range	T_{STG}	-40 to +150	°C

Notes:

1. EU Directive 2002/95/EC (RoHS), 2011/65/EU (RoHS 2) & 2015/863/EU (RoHS 3) compliant. All applicable RoHS exemptions applied.
2. See <https://www.diodes.com/quality/lead-free/> for more information about Diodes Incorporated's definitions of Halogen- and Antimony-free, "Green" and Lead-free.
3. Halogen- and Antimony-free "Green" products are defined as those which contain <900ppm bromine, <900ppm chlorine (<1500ppm total Br + Cl) and <1000ppm antimony compounds.
4. V_{DRM} and V_{RRM} for all types can be applied on a continuous basis. Ratings apply for zero or negative gate voltage; positive gate voltage shall not be applied concurrent with negative potential on the anode. Blocking voltages shall not be tested with a constant current source such that the voltage ratings of the devices are exceeded.

**RATING AND CHARACTERISTIC CURVES
S12M15600B**

THERMAL CHARACTERISTICS

CHARACTERISTICS	SYMBOL	VALUE	UNIT
Thermal Resistance - Junction to Case - Junction to Ambient	RthJC RthJA	2.2 62.5	°C/W
Maximum Lead Temperature for Soldering Purposes 1/16" from Case for 10 Seconds	T _L	260	°C

ELECTRICAL CHARACTERISTICS (T_J = 25°C unless otherwise specified)

OFF CHARACTERISTICS

CHARACTERISTICS	SYMBOL	MAX	UNIT
Peak Repetitive Forward or Reverse Blocking Current (V _D = Rated V _{DRM} and V _{RRM} ; Gate Open)	I _{DRM} I _{RRM}	10 2.0	μA mA

ON CHARACTERISTICS

CHARACTERISTICS	SYMBOL	MIN	TYP	MAX	UNIT
Peak Forward On-State Voltage (I _{TM} = 24A Peak, Pulse Width ≤ 2.0ms, Duty Cycle ≤ 2%)	V _{TM}	--	--	2.2	V
Gate Trigger Current (V _D = 12 V, R _L = 100 Ohms)	I _{GT}	2.0	8.0	15	mA
Holding Current (V _D = 12 V, Gate Open, Initiating Current = 200mA)	I _H	4.0	20	40	mA
Gate Trigger Voltage (V _D = 12V, R _L = 100 Ohms)	V _{GT}	0.5	0.65	1.0	V
Latch Current (V _D = 12V, I _G = 20mA)	I _L	6.0	25	60	mA

DANAMIC CHARACTERISTICS

CHARACTERISTICS	SYMBOL	MIN.	TYP.	MAX	UNIT
Critical Rate of Rise of Off-State Voltage (V _D = Rated V _{DRM} , Exponential Waveform, Gate open, T _J = 125°C)	dv/dt	100	250	--	V/us
Repetitive Critical Rate of Rise of On-State Current (I _{PK} = 50A, P _W = 40us, di/dt = 1A/us, I _{GT} = 50mA)	di/dt	--	--	50	A/us

RATING AND CHARACTERISTIC CURVES
S12M15600B

Voltage Current Characteristic of SCR

Symbol	Parameter
V_{DRM}	Peak Repetitive Off State Forward Voltage
I_{DRM}	Peak Forward Blocking Current
V_{RRM}	Peak Repetitive Off State Reverse Voltage
I_{RRM}	Peak Reverse Blocking Current
V_{TM}	Peak on State Voltage
I_H	Holding Current

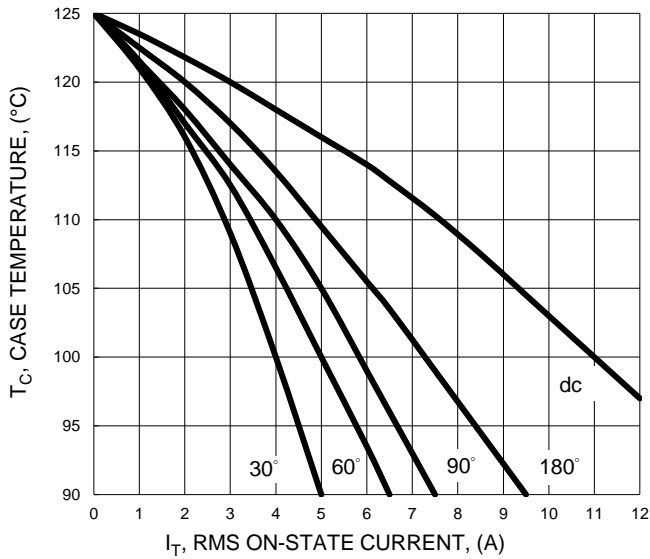
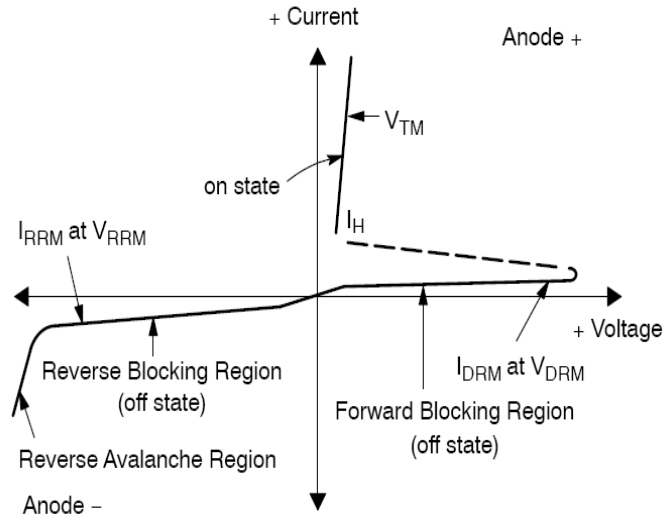

Figure 1. Typical RMS Current De-rating

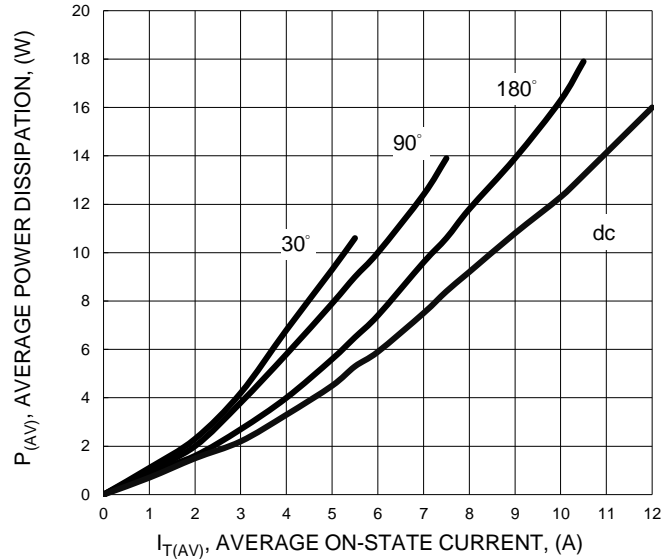

Figure 2. On-State Power Dissipation

RATING AND CHARACTERISTIC CURVES
S12M15600B

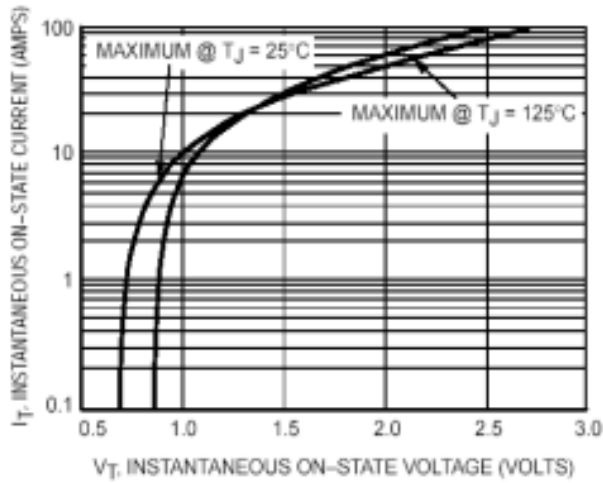

Figure 3. Typical On-State Characteristics

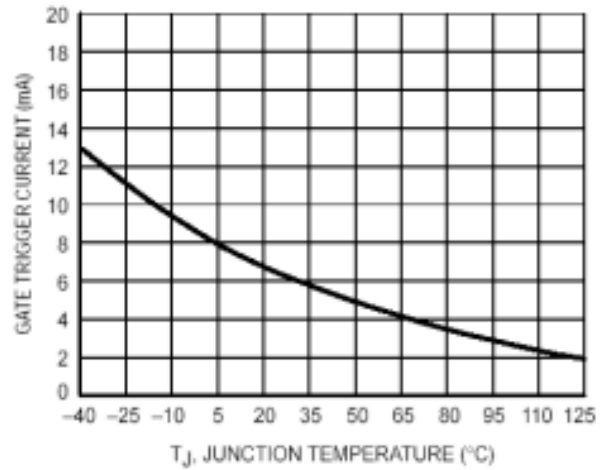

Figure 4. Typical Gate Trigger Current versus Junction Temperature

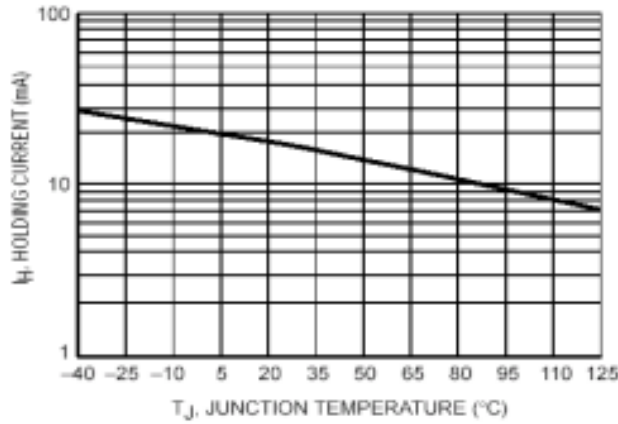

Figure 5. Typical Holding Current versus Junction Temperature

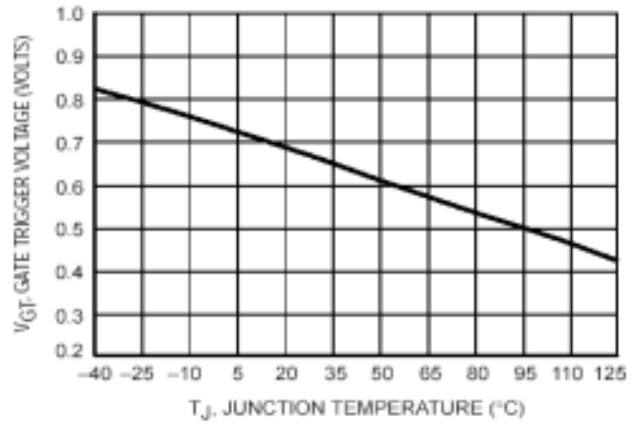

Figure 6. Typical Gate Trigger Voltage versus Junction Temperature

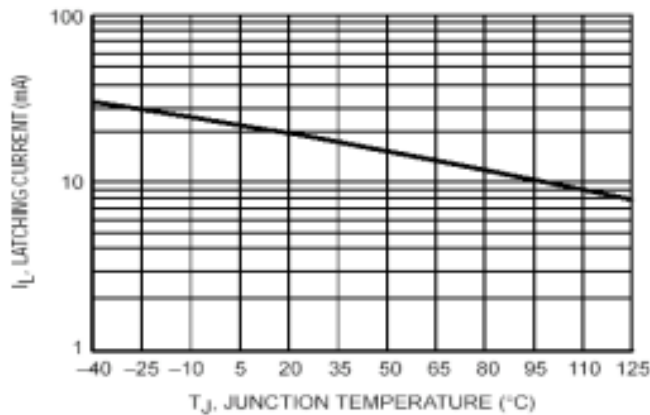
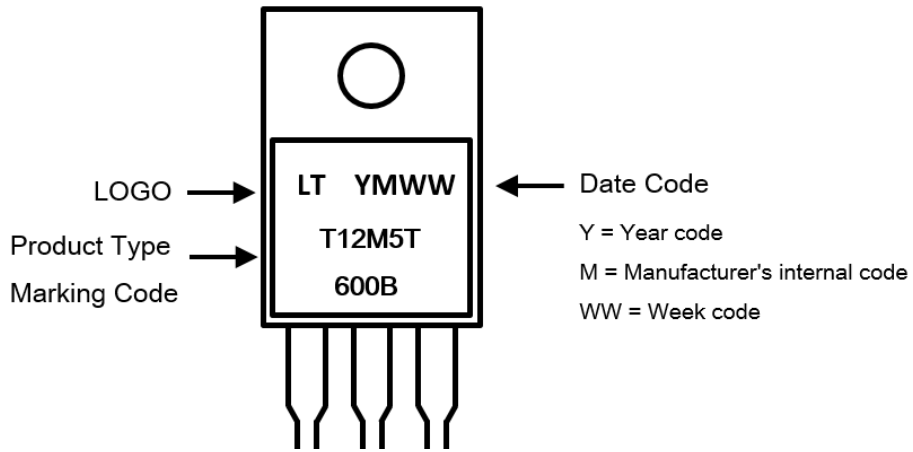

Figure 7. Typical Latching Current versus Junction Temperature

Ordering Information:

Part Number	Package	Packing	
		Qty.	Carrier
S12M15600B	TO-220AB	50pcs	Tube

Marking Information:



IMPORTANT NOTICE

1. DIODES INCORPORATED AND ITS SUBSIDIARIES ("DIODES") MAKE NO WARRANTY OF ANY KIND, EXPRESS OR IMPLIED, WITH REGARDS TO ANY INFORMATION CONTAINED IN THIS DOCUMENT, INCLUDING, BUT NOT LIMITED TO, THE IMPLIED WARRANTIES OF MERCHANTABILITY, FITNESS FOR A PARTICULAR PURPOSE OR NON-INFRINGEMENT OF THIRD PARTY INTELLECTUAL PROPERTY RIGHTS (AND THEIR EQUIVALENTS UNDER THE LAWS OF ANY JURISDICTION).
2. The Information contained herein is for informational purpose only and is provided only to illustrate the operation of Diodes products described herein and application examples. Diodes does not assume any liability arising out of the application or use of this document or any product described herein. This document is intended for skilled and technically trained engineering customers and users who design with Diodes products. Diodes products may be used to facilitate safety-related applications; however, in all instances customers and users are responsible for (a) selecting the appropriate Diodes products for their applications, (b) evaluating the suitability of the Diodes products for their intended applications, (c) ensuring their applications, which incorporate Diodes products, comply the applicable legal and regulatory requirements as well as safety and functional-safety related standards, and (d) ensuring they design with appropriate safeguards (including testing, validation, quality control techniques, redundancy, malfunction prevention, and appropriate treatment for aging degradation) to minimize the risks associated with their applications.
3. Diodes assumes no liability for any application-related information, support, assistance or feedback that may be provided by Diodes from time to time. Any customer or user of this document or products described herein will assume all risks and liabilities associated with such use, and will hold Diodes and all companies whose products are represented herein or on Diodes' websites, harmless against all damages and liabilities.
4. Products described herein may be covered by one or more United States, international or foreign patents and pending patent applications. Product names and markings noted herein may also be covered by one or more United States, international or foreign trademarks and trademark applications. Diodes does not convey any license under any of its intellectual property rights or the rights of any third parties (including third parties whose products and services may be described in this document or on Diodes' website) under this document.
5. Diodes products are provided subject to Diodes' Standard Terms and Conditions of Sale (<https://www.diodes.com/about/company/terms-and-conditions/terms-and-conditions-of-sales/>) or other applicable terms. This document does not alter or expand the applicable warranties provided by Diodes. Diodes does not warrant or accept any liability whatsoever in respect of any products purchased through unauthorized sales channel.
6. Diodes products and technology may not be used for or incorporated into any products or systems whose manufacture, use or sale is prohibited under any applicable laws and regulations. Should customers or users use Diodes products in contravention of any applicable laws or regulations, or for any unintended or unauthorized application, customers and users will (a) be solely responsible for any damages, losses or penalties arising in connection therewith or as a result thereof, and (b) indemnify and hold Diodes and its representatives and agents harmless against any and all claims, damages, expenses, and attorney fees arising out of, directly or indirectly, any claim relating to any noncompliance with the applicable laws and regulations, as well as any unintended or unauthorized application.
7. While efforts have been made to ensure the information contained in this document is accurate, complete and current, it may contain technical inaccuracies, omissions and typographical errors. Diodes does not warrant that information contained in this document is error-free and Diodes is under no obligation to update or otherwise correct this information. Notwithstanding the foregoing, Diodes reserves the right to make modifications, enhancements, improvements, corrections or other changes without further notice to this document and any product described herein. This document is written in English but may be translated into multiple languages for reference. Only the English version of this document is the final and determinative format released by Diodes.
8. Any unauthorized copying, modification, distribution, transmission, display or other use of this document (or any portion hereof) is prohibited. Diodes assumes no responsibility for any losses incurred by the customers or users or any third parties arising from any such unauthorized use.

Copyright © 2022 Diodes Incorporated

www.diodes.com

Looking for pricing, stock, or lifecycle information?

Click below to explore more details on WIN SOURCE:

-  [View S12M15600B on WIN SOURCE](#)
-  [Diodes Incorporated Information](#)

Optimize Your Supply Chain with WIN SOURCE Solutions

-  Global Sourcing Solution
-  Obsolete Management
-  Cost Control Management
-  Shortage Management
-  Alternative Solution
-  Excess Inventory Management