



THE DATASHEET OF MM3825ACCYLE



1cell Li-ion/Li-polymer battery protection IC

MM3825 Series

Description

The MM3825 series are protection IC using high voltage CMOS process for overcharge, overdischarge and overcurrent protection of the rechargeable Lithium-ion or Lithium-polymer battery. The overcharge, overdischarge, discharging overcurrent, charging overcurrent, and short protection of the rechargeable one-cell Lithium-ion or Lithium-polymer battery can be detected. Each of these IC composed of four voltage detectors, short detection circuit, reference voltage sources, oscillator, counter circuit and logical circuits.

Features

(Unless otherwise specified, Ta=25 degC)

•Detection voltage	Range	Accuracy
Overcharge detection voltage	3.6V to 5.0V, 5mV steps	+/-20mV +/-25mV(Ta=-20 to +60 degC)
Overdischarge detection voltage	2.0V to 3.0V, 50mV steps	+/-35mV
Discharging overcurrent detection voltage	20mV to +300mV, 1mV steps	+/-2.5mV +/-3.0mV(Ta=-20 to +60 degC)
Charging overcurrent detection voltage	-20mV to -300mV, 1mV steps	+/-2.5mV +/-3.0mV(Ta=-20 to +60 degC)
Short detection voltage	70mV to 350mV, 1mV steps	+/-8%
0V battery charge inhibition battery voltage	1.1V to 2.4V, 0.1V steps	+/-0.1V
	0.9V	+/-0.3V
•0V battery charge function	Selectable "Permission" or "inhibition"	
•Current consumption at Ta=25 degC		
Normal mode	2.5uA typ. 4.0uA max.	
Standby mode	0.1uA max. (Overdischarge latch function enable.) 0.5uA max. (Overdischarge latch function disable.)	
MM3825Txx Series		
Normal mode	2.0uA typ. 3.0uA max.	
Standby mode	0.05uA max. (Overdischarge latch function enable.) 0.5uA max. (Overdischarge latch function disable.)	

Applications

- Lithium-ion rechargeable battery pack
- Lithium polymer rechargeable battery pack

Package type

- SSON-6J/6M 1.40 × 1.40 × 0.55 [mm]
- SON-6C 1.60 × 1.60 × 0.55 [mm]

Block diagram

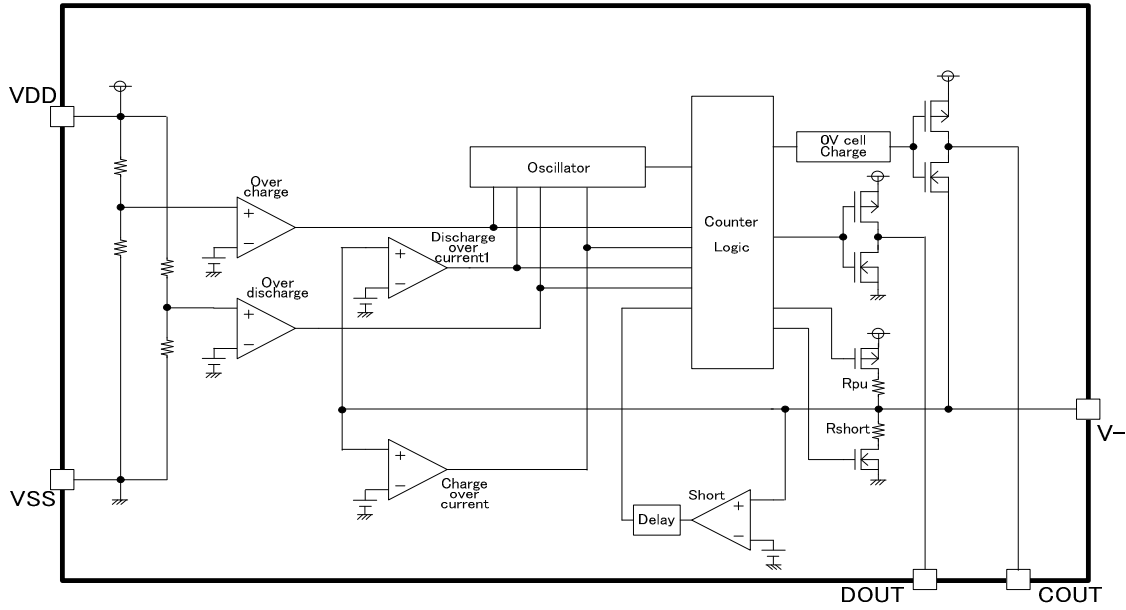

Package and pin configuration

SSON-6J/6M		Pin No.	Symbol	Function
	1	NC	No connection	
	2	COUT	Charge FET control terminal	
	3	DOUT	Discharge FET control terminal	
	4	VSS	Negative power supply voltage input terminal	
	5	VDD	Positive power supply voltage input terminal	
	6	V-	Negative power supply voltage input terminal.	

SON-6F		Pin No.	Symbol	Function
	1	NC	No connection	
	2	COUT	Charge FET control terminal	
	3	DOUT	Discharge FET control terminal	
	4	VSS	Negative power supply voltage input terminal	
	5	VDD	Positive power supply voltage input terminal	
	6	V-	Negative power supply voltage input terminal.	

Package dimensions

Unit:mm

SON-6C

Top View

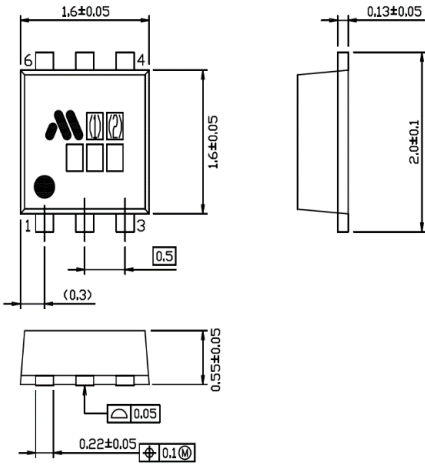

Bottom View

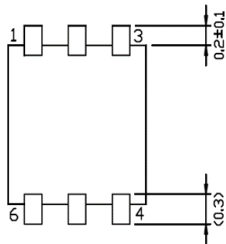

Marking Contents / SON-6C

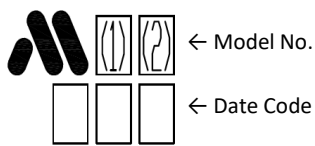

SSON-6J

Top View

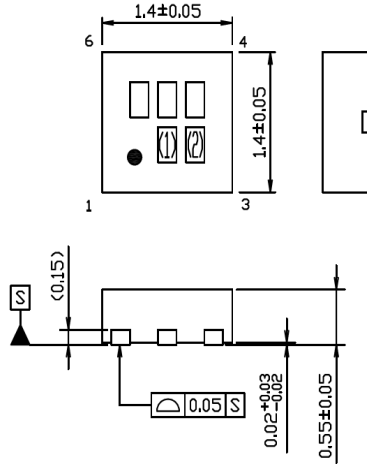

Bottom View

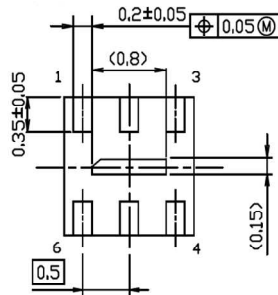

Marking Contents / SSON-6J

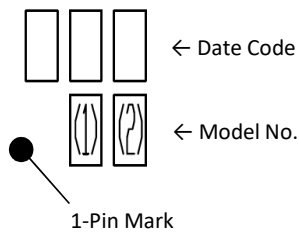

SSON-6M

Top View

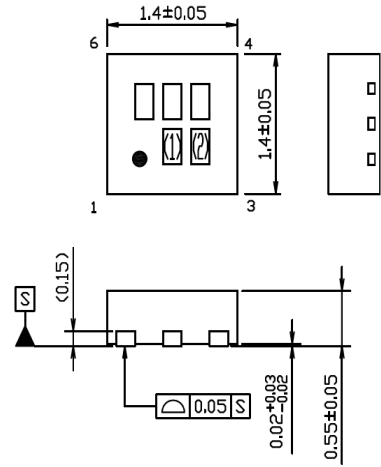

Bottom View

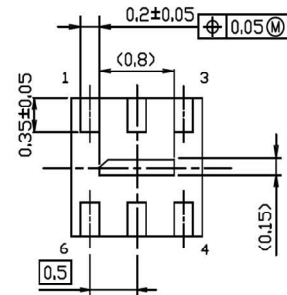

Marking Contents / SSON-6M

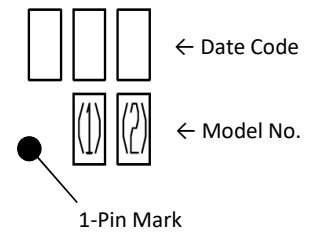

Absolute maximum ratings

Parameter	Symbol	Rating	Unit
Supply voltage	VDD	-0.3 to 12	V
V- terminal	V-	VDD-28 to VDD+0.3	V
COUT terminal	VCOUT	VDD-28 to VDD+0.3	V
DOUT terminal	VDOUT	VSS-0.3 to VDD+0.3	V
Storage temperature	Tstg	-55 to +125	degC

Recommend operating conditions

Parameter	Symbol	Rating	Unit
Operating ambient temperature	Topr	-40 to +85	degC
Operating voltage	Vop	1.5 to 5.5	V

Electrical characteristics

(Unless otherwise specified, Ta=25 degC)

Item	Unit	Symbol	Note	Min	Typ	Max
Operating voltage	V	Vop		1.5	-	5.5
Operating Ambient temperature	degC	Ta		-40	-	85
Discharge overcurrent release resistance	kohms	Rshort	VDD=3.6V, V-=2.0V	Rshort*0.6	Rshort	Rshort*2.0
V- terminal pull-up resistances	kohms	Rpu	VDD=2.0V, V-=0V	Rpu*0.5	Rpu	Rpu*2.0
COUT L level output voltage	V	VcoL	Icout=30uA, VDD=4.5V	-	0.1	0.5
COUT H level output voltage	V	VcoH	Icout=-30uA, VDD=4.0V	VDD-0.5	VDD-0.1	-
DOUT L level output voltage	V	VdoL	Icout=30uA, VDD=2.0V	-	0.1	0.5
DOUT H level output voltage	V	VdoH	Icout=-30uA, VDD=4.0V	VDD-0.5	VDD-0.1	-
Current consumption	uA	Idd	VDD=4.0V, V-=0V	-	2.5	4.0
Current consumption at stand-by	uA	Is	VDD=2.0V *3	-	-	0.1
			VDD=2.0V *4	-	0.3	0.5
0V battery charge permission charger voltage	V	Vst	Vst=VDD-V-, VDD=0V *1	-	-	1.2
0V battery charge inhibition battery voltage	V		Vst=VDD-VSS, V-=0V *2	Vst-0.1	Vst	Vst+0.1
Overcharge detection voltage	V	Vdet1	Ta=-20 to 60degC, V-=0V	Vdet1-0.020	Vdet1	Vde1+0.020
Overcharge release voltage	V	Vrel1	*5	Vrel1-0.030	Vrel1	Vrel1+0.030
Overdischarge detection voltage	V	Vdet2	V-=0V	Vdet1-0.035	Vdet2	Vde1+0.035
Overdischarge release voltage	V	Vrel2	In case Vdet2=Vrel2 *3 *5	Vrel2-0.035	Vrel2	Vrel2+0.050
			In case Vdet2≠Vrel2 *4 *5	Vdet1-0.065		Vdet1+0.090
Discharging overcurrent detection voltage	V	Vdet3	VDD=3.6V, V-=0V *6	Vdet3- Δ V	Vdet3	Vdet3+ Δ V
Charging overcurrent detection voltage	V	Vdet4	VDD=3.6V, V-=0V *6	Vdet4- Δ V	Vdet4	Vdet4+ Δ V
Short detection voltage	V	Vshort	VDD=3.6V	Vshort*0.92	Vshort	Vshort*1.08
Overcharge detection delay time	ms	tVdet1		tVdet1*0.8	tVdet1	tVdet1*1.2
Overdischarge detection delay time	ms	tVdet2		tVdet2*0.8	tVdet2	tVdet2*1.2
Discharging overcurrent detection delay time	ms	tVdet3		tVdet3*0.8	tVdet3	tVdet3*1.2
Charging overcurrent detection delay time	ms	tVdet4		tVdet4*0.8	tVdet4	tVdet4*1.2
Short detection delay time	us	tVshort		tVshort*0.7	tVshort	tVshort*1.4

*1 In case 0V battery charge function "Permission".

*2 In case 0V battery charge function "inhibition".

*3 Overdischarge mode latch function "Enable".

*4 Overdischarge mode latch function "Disable".

*5 Please refer to each specifications for release condition.

*6 Current detection voltage Accuracy

Typical application circuit

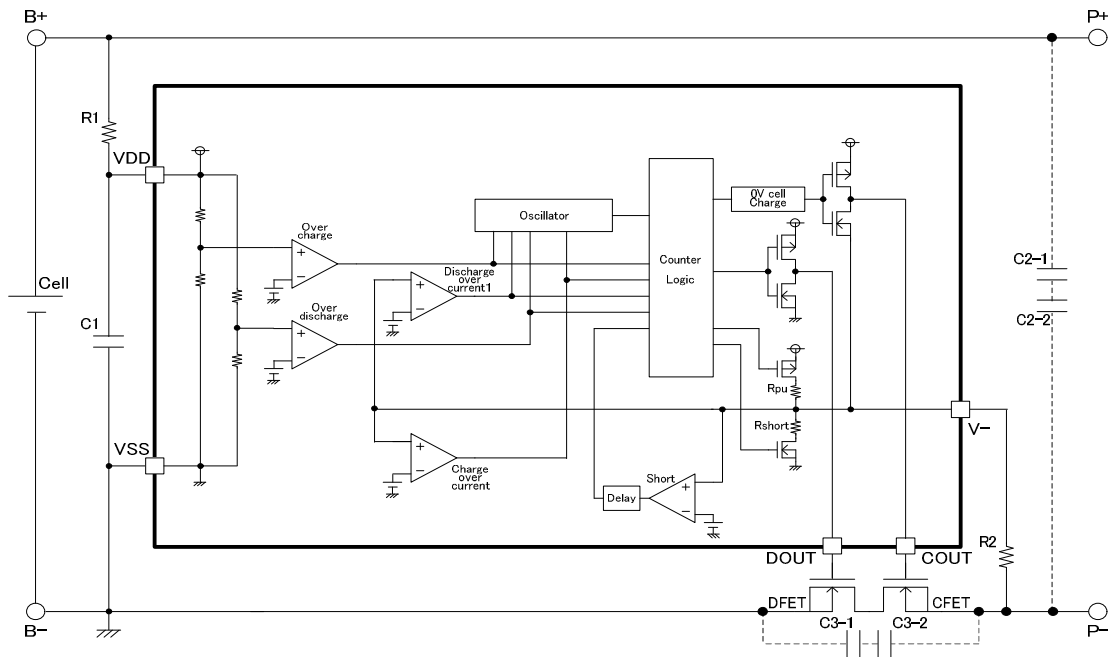

Symbol	Part	Min.	Typ.	Max.	Purpose
R1	Resistor	-	100Ω	1.0kΩ	For voltage fluctuation, For ESD
C1	Capacitor	0.01uF	0.1uF	1.0uF	For voltage fluctuation
R2	Resistor	-	1.0kΩ	1.0kΩ	Current limit for charger reverse connection
C2	Capacitor	-	0.1uF	-	For exogenous noise
C3	Capacitor	-	0.1uF	-	For exogenous noise
DFET, CFET	Nch MOS FET	-	-	-	Charge and discharge control

Application hints

R1 and C1 stabilize a supply voltage fluctuation. However, the detection voltage rises by the current consumption of IC when R1 is too large, and please use 1kohm or less for R1. Please use 0.01uF or more for C1 to stabilize the operation.

Lineup

MODEL	PKG	OV charge	Protection mode latch function			Hys-Cancel		Overcharge detection voltage	Overcharge release voltage	Overdischarge detection voltage	Overdischarge release voltage	Discharging overcurrent detection voltage	Charging overcurrent detection voltage	Short detection voltage1
			Overcharge	Overdischarge	Discharge overcurrent	Overcharge	Overdischarge							
			Vdet1 [V]	Vrel1 [V]	Vdet2 [V]	Vrel2 [V]	Vdet3 [mV]	Vdet4 [mV]	Vshort [mV]					
MM3825ACCYLE	SON-6C	0.9	Disable	Disable	Disable	Enable	Disable	4.475	4.275	2.500	2.900	20.0	-20.0	70.0
MM3825CM1RRE	SSON-6J	1.1	Disable	Enable	Disable	Enable	Enable	4.275	4.175	2.400	2.400	90.0	-25.0	250.0
MM3825CM3YRE	SON-6C	0.9	Disable	Enable	Disable	Enable	Enable	4.475	4.275	2.700	2.700	45.0	-45.0	145.0
MM3825CN3YRE	SON-6C	Permission	Disable	Enable	Disable	Enable	Enable	4.475	4.275	2.500	2.500	30.0	-30.0	105.0
MM3825TM3YRE	SON-6C	0.9	Disable	Disable	Disable	Enable	Disable	4.475	4.275	2.500	2.800	60.0	-60.0	190.0
MM3825TM4RRE	SSON-6J	2.1	Disable	Enable	Disable	Enable	Enable	4.200	4.000	2.800	2.800	50.0	-50.0	150.0
MM3825TN1YRE	SON-6C	Permission	Disable	Enable	Disable	Enable	Enable	4.495	4.295	2.500	2.500	45.0	-45.0	150.0

Delay time

MODEL	tVdet1 [s]	tVrel1 [ms]	tVdet2 [ms]	tVrel2 [ms]	tVdet3 [ms]	tVrel3 [ms]	tVdet4 [ms]	tVrel4 [ms]	tshort [us]
MM3825ACCYLE	1.024	16.00	64.00	1.00	16.00	1.00	16.00	1.00	280
MM3825CM1RRE	1.024	16.00	32.00	1.00	24.00	1.00	8.00	1.00	250
MM3825CM3YRE	1.024	16.00	32.00	1.00	16.00	1.00	8.00	1.00	280
MM3825CN3YRE	1.024	16.00	32.00	1.00	8.00	1.00	8.00	1.00	280
MM3825TM3YRE	1.024	16.00	20.00	1.00	12.00	1.00	8.00	1.00	280
MM3825TM4RRE	1.024	8.00	128.00	1.00	8.00	1.00	8.00	1.00	280
MM3825TN1YRE	1.024	16.00	32.00	1.00	32.00	1.00	8.00	1.00	280

NOTES

【Safety Precautions】

- Though Mitsumi Electric Co., Ltd. (hereinafter referred to as "Mitsumi") works continually to improve our product's quality and reliability, semiconductor products may generally malfunction or fail. Customers are responsible for complying with safety standards and for providing adequate designs and safeguards for their hardware, software and systems which minimize risk and avoid situations in which a malfunction or failure of this product could cause loss of human life, bodily injury, or damage to property, including data loss or corruption. Before customers use this product, create designs including this product, or incorporate this product into their own applications, customers must also refer to and comply with (a) the latest versions or all of our relevant information, including without limitation, product specifications, data sheets and application notes for this product and (b) the user's manual, handling instructions or all relevant information for any products which is to be used, or combined with this products. Customers are solely responsible for all aspects of their own product design or applications, including but not limited to (a) determining the appropriateness of the use of this product in such design or applications; (b) evaluating and determining the applicability of any information contained in this document, or in charts, diagrams, programs, algorithms, sample application circuits, or any other referenced documents; and (c) validating all operating parameters for such designs and applications. Mitsumi assumes no liability for customers' product design or applications.
- This product is intended for applying to computers, OA units, communication units, instrumentation units, machine tools, industrial robots, AV units, household electrical appliances, and other general electronic units.

【Precautions for Product Liability Act】

- No responsibility is assumed by us for any consequence resulting from any wrong or improper use or operation, etc. of this product.

【ATTENTION】

- This product is designed and manufactured with the intention of normal use in general electronics. No special circumstance as described below is considered for the use of it when it is designed. With this reason, any use and storage under the circumstances below may affect the performance of this product. Prior confirmation of performance and reliability is requested to customers.
 - Environment with strong static electricity or electromagnetic wave
 - Environment with high temperature or high humidity where dew condensation may occur
- This product is not designed to withstand radioactivity, and must avoid using in a radioactive environment.
- This specification is written in Japanese and English. The English text is faithfully translated into the Japanese. However, if any question arises, Japanese text shall prevail.

Looking for pricing, stock, or lifecycle information?

Click below to explore more details on WIN SOURCE:

- ⊖ [View MM3825ACCYLE on WIN SOURCE](#)
- ⊖ [Mitsumi Information](#)

Optimize Your Supply Chain with WIN SOURCE Solutions

- ✓ Global Sourcing Solution
- ✓ Obsolete Management
- ✓ Cost Control Management
- ✓ Shortage Management
- ✓ Alternative Solution
- ✓ Excess Inventory Management