



**THE DATASHEET OF  
CY8C4145AZI-PS433**



# PSoC™ 4100PS

Based on Arm® Cortex™-M0+

## General description

Infineon's PSoC™ 4 is a scalable and reconfigurable platform architecture for a family of programmable embedded system controllers with an Arm® Cortex®-M0+ CPU. It combines programmable and reconfigurable analog and digital blocks with flexible automatic routing. PSoC™ 4100PS is a member of the PSoC™ 4 platform architecture. It is a combination of a microcontroller with standard communication and timing peripherals, a capacitive touch-sensing system (CAPSENSE™) with best-in-class performance, programmable general-purpose continuous-time and switched-capacitor analog blocks, and programmable connectivity.

## Features

- Programmable analog blocks
  - Two dedicated analog-to-digital converters (ADC) including a 12-bit SAR ADC and a 10-bit single-slope ADC
  - Four opamps, two low-power comparators, and a flexible 38-channel analog mux to create custom Analog Front Ends (AFE)
  - Two 13-bit voltage DACs
  - Two 7-bit current DACs (IDACs) for general-purpose or capacitive sensing applications on any pin
- CAPSENSE™ capacitive sensing
  - Infineon's fourth-generation CAPSENSE™ Sigma-Delta (CSD) providing best-in-class signal-to-noise ratio (SNR) and water tolerance
  - Infineon-supplied software component makes capacitive sensing design easy
  - Automatic hardware tuning (SmartSense™)
- Segment LCD drive
  - LCD drive supported on all pins (common or segment)
  - Operates in Deep-Sleep mode with four bits per pin memory
- Programmable digital peripherals
  - Three independent serial communication blocks (SCBs) that are run-time configurable as I2C, SPI or UART
  - Eight 16-bit timer/counter/pulse-width modulator (TCPWM) blocks with center-aligned, edge, and pseudo-random modes
- 32-bit signal processing engine
  - Arm® Cortex®-M0+ CPU up to 48 MHz
  - Up to 32 KB of flash with read accelerator
  - Up to 4 KB of SRAM
  - Eight-channel descriptor-based DMA controller
- Low-power operation
  - 1.71-V to 5.5-V operation
  - Deep-Sleep mode with operational analog and 2.5-µA digital system current
  - Watch crystal oscillator (WCO)
- Programmable GPIO pins
  - Up to 38 GPIOs that can be used for analog, digital, CAPSENSE™, or LCD functions with programmable drive modes, strength and slew rates
  - Includes eight Smart I/Os to implement pin-level Boolean operations on input and output signals
  - 48-pin QFN, 48-pin TQFP, 28-pin SSOP, and 45-ball WLCSP packages

## Features

- PSoC™ Creator Design Environment
  - Integrated Design Environment (IDE) provides schematic-capture design entry and build (with automatic routing of analog and digital signals) and concurrent firmware development with an Arm®-SWD debugger
  - GUI-based configurable PSoC™ Components with fully engineered embedded initialization, calibration and correction algorithms
  - Application programming interfaces (API) for all fixed-function and programmable peripherals
- Industry-standard tool compatibility
  - After schematic-capture, firmware development can be done with Arm-based industry-standard development tools

More information

## More information

Infineon provides a wealth of data at [www.infineon.com](http://www.infineon.com) to help you to select the right PSoC™ device for your design, and to help you to quickly and effectively integrate the device into your design. For a comprehensive list of resources, see the knowledge base article [KBA86521, How to Design with PSoC™ 3, PSoC™ 4, and PSoC™ 5LP](#). Following is an abbreviated list for PSoC™ 4:

- Overview: [MCU Portfolio](#)
- Product selectors: [PSoC™ 1](#), [PSoC™ 3](#), [PSoC™ 4](#), [PSoC™ 5LP](#), [PSoC™ 6](#)  
In addition, PSoC™ Creator includes a device selection tool.
- Application notes: Infineon offers a large number of PSoC™ application notes covering a broad range of topics, from basic to advanced level. Recommended application notes for getting started with PSoC™ 4 are:
  - [AN79953](#): Getting Started With PSoC™ 4
  - [AN88619](#): PSoC™ 4 Hardware Design Considerations
  - [AN86439](#): Using PSoC™ 4 GPIO Pins
  - [AN57821](#): Mixed Signal Circuit Board Layout
  - [AN81623](#): Digital Design Best Practices
  - [AN73854](#): Introduction To Bootloaders
  - [AN89610](#): Arm® Cortex® Code Optimization
  - [AN85951](#): PSoC™ 4 and PSoC™ Analog Coprocessor CAPSENSE™ Design Guide
- Technical reference manual (TRM) is in two documents:
  - [Architecture TRM](#) details each PSoC™ 4 functional block.
  - [Registers TRM](#) describes each of the PSoC™ 4 registers.
- Development kits:
  - [CY8CKIT-147](#), PSoC™ 4100PS Prototyping Kit enables you to evaluate and develop with PSoC™ 4100PS devices at a low cost.

The [MiniProg3](#) device provides an interface for flash programming and debug.

- **Software user guide:**
  - A step-by-step guide for using PSoC™ Creator. The software user guide shows you how the PSoC™ Creator build process works in detail, how to use source control with PSoC™ Creator, and much more.
- Component datasheets:
  - The flexibility of PSoC™ allows the creation of new peripherals (components) long after the device has gone into production. Component datasheets provide all the information needed to select and use a particular component, including a functional description, API documentation, example code, and AC/DC specifications.
- Online:
  - In addition to print documentation, the [Infineon Developer Community](#) connect you with fellow PSoC™ users and experts in PSoC™ from around the world, 24 hours a day, 7 days a week.

## PSoC™ Creator

**PSoC™ Creator** is a free Windows-based Integrated Design Environment (IDE). It enables concurrent hardware and firmware design of PSoC™ 3, PSoC™ 4, and PSoC™ 5LP based systems. Create designs using classic, familiar schematic capture supported by over 100 pre-verified, production-ready PSoC™ Components; see the [list of component datasheets](#). With PSoC™ Creator, you can:

1. Drag and drop component icons to build your hardware system design in the main design workspace
2. Codesign your application firmware with the PSoC™ hardware, using the PSoC™ Creator IDE C compiler
3. Configure components using the configuration tools
4. Explore the library of 100+ components
5. Review component datasheets

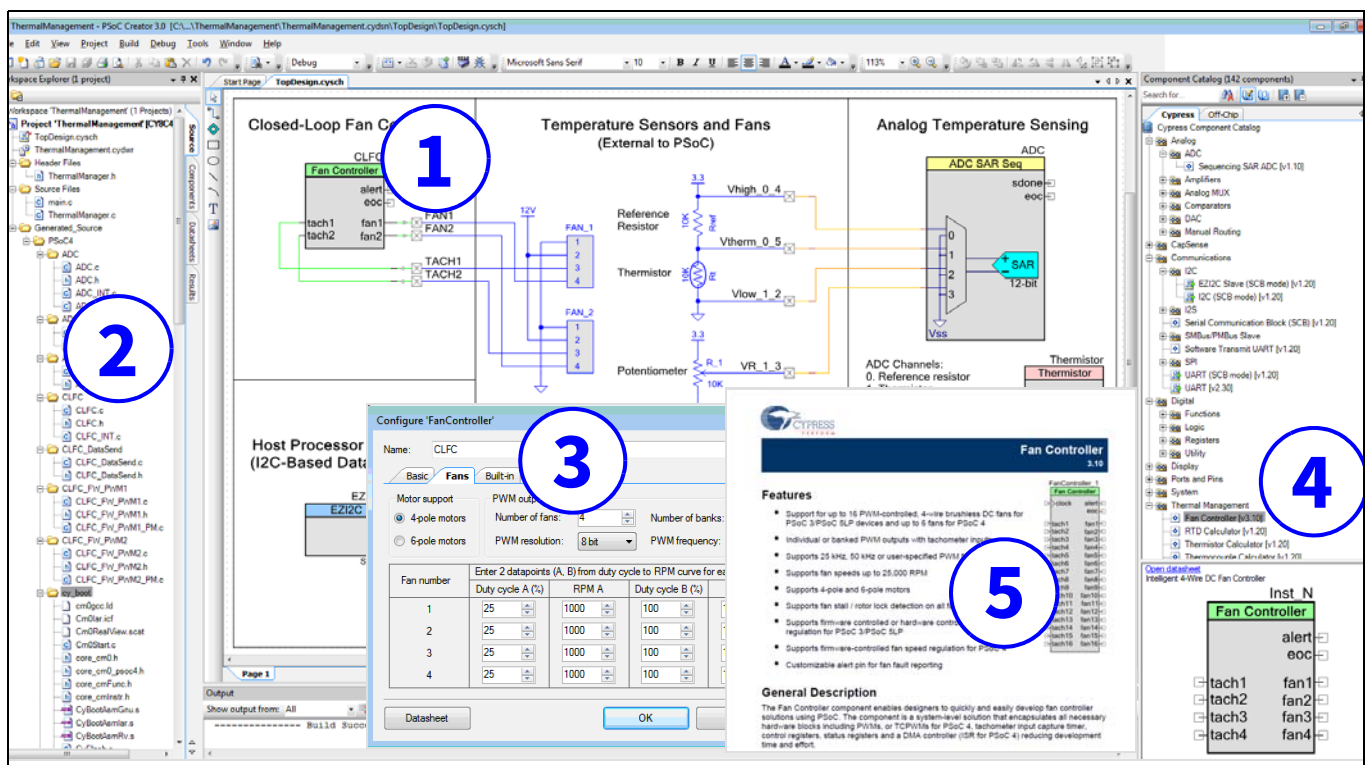

**Figure 1 Multiple-sensor example project in PSoC™ Creator**

## Table of contents

<b>General description</b> .....	<b>1</b>
<b>Features</b> .....	<b>1</b>
<b>More information</b> .....	<b>3</b>
<b>PSoC™ Creator</b> .....	<b>4</b>
<b>Table of contents</b> .....	<b>5</b>
<b>1 Functional overview</b> .....	<b>7</b>
<b>2 Functional definition</b> .....	<b>9</b>
2.1 CPU and memory subsystem .....	9
2.1.1 CPU .....	9
2.1.2 DMA/DataWire .....	9
2.1.3 Flash .....	9
2.1.4 SRAM .....	9
2.1.5 SROM .....	9
2.2 System resources .....	10
2.2.1 Power system .....	10
2.2.2 Clock system .....	10
2.2.3 IMO clock source .....	10
2.2.4 ILO clock source .....	11
2.2.5 Watch crystal oscillator (WCO) .....	11
2.2.6 Watchdog timer .....	11
2.2.7 Reset .....	11
2.2.8 Voltage reference .....	11
2.3 Analog blocks .....	12
2.3.1 12-bit SAR ADC .....	12
2.3.2 Four opamps (Continuous-time block; CTB) .....	12
2.3.3 VDAC (13 bits) .....	13
2.3.4 Low-power comparators (LPC) .....	13
2.3.5 Current DACs .....	13
2.3.6 Analog multiplexed buses .....	13
2.3.7 Temperature sensor .....	13
2.4 Fixed Function Digital .....	13
2.4.1 Timer/Counter/PWM (TCPWM) block .....	13
2.4.2 Serial Communication block (SCB) .....	14
2.5 GPIO .....	14
2.6 Special Function Peripherals .....	15
2.6.1 CAPSENSE™ .....	15
2.7 WLCSP Package Bootloader .....	15
<b>3 Pinouts</b> .....	<b>16</b>
3.1 Alternate pin functions .....	18
<b>4 Power</b> .....	<b>21</b>
4.1 Mode 1: 1.8 V to 5.5 V External Supply .....	21
4.2 Mode 2: 1.8 V ± 5% External Supply .....	22
<b>5 Development support</b> .....	<b>23</b>
5.1 Documentation .....	23
5.2 Online .....	23
5.3 Tools .....	23
<b>6 Electrical specifications</b> .....	<b>24</b>
6.1 Absolute maximum ratings .....	24
6.2 Device Level Specifications .....	25
6.2.1 GPIO .....	27
6.2.2 XRES .....	29

Table of contents

6.3 Analog peripherals.....	30
6.3.1 CTB Opamp .....	30
6.3.2 PGA .....	35
6.3.3 Voltage DAC.....	36
6.3.4 Comparator .....	37
6.3.5 Temperature Sensor .....	38
6.3.6 SAR.....	39
6.3.7 CAPSENSE™ and IDAC.....	41
6.4 Digital Peripherals .....	45
6.4.1 Timer Counter Pulse-Width Modulator (TCPWM).....	45
6.4.2 I <sup>2</sup> C .....	46
6.4.3 SPI.....	47
6.4.4 UART .....	48
6.4.5 LCD.....	48
6.5 Memory.....	49
6.5.1 Flash .....	49
6.6 System resources.....	50
6.6.1 Power-on Reset (POR) .....	50
6.6.2 SWD Interface.....	50
6.6.3 Internal Main Oscillator (IMO) .....	51
6.6.4 Internal low-speed oscillator (ILO) .....	51
6.6.5 Watch Crystal Oscillator (WCO) .....	52
6.6.6 External Clock .....	52
6.6.7 Block.....	52
6.6.8 PRGIO Pass-through Time .....	52
<b>7 Ordering information .....</b>	<b>53</b>
<b>8 Packaging .....</b>	<b>55</b>
8.1 Package diagrams.....	56
<b>9 Acronyms .....</b>	<b>60</b>
<b>10 Document conventions .....</b>	<b>64</b>
10.1 Units of measure .....	64
<b>Revision history .....</b>	<b>65</b>

# 1 Functional overview

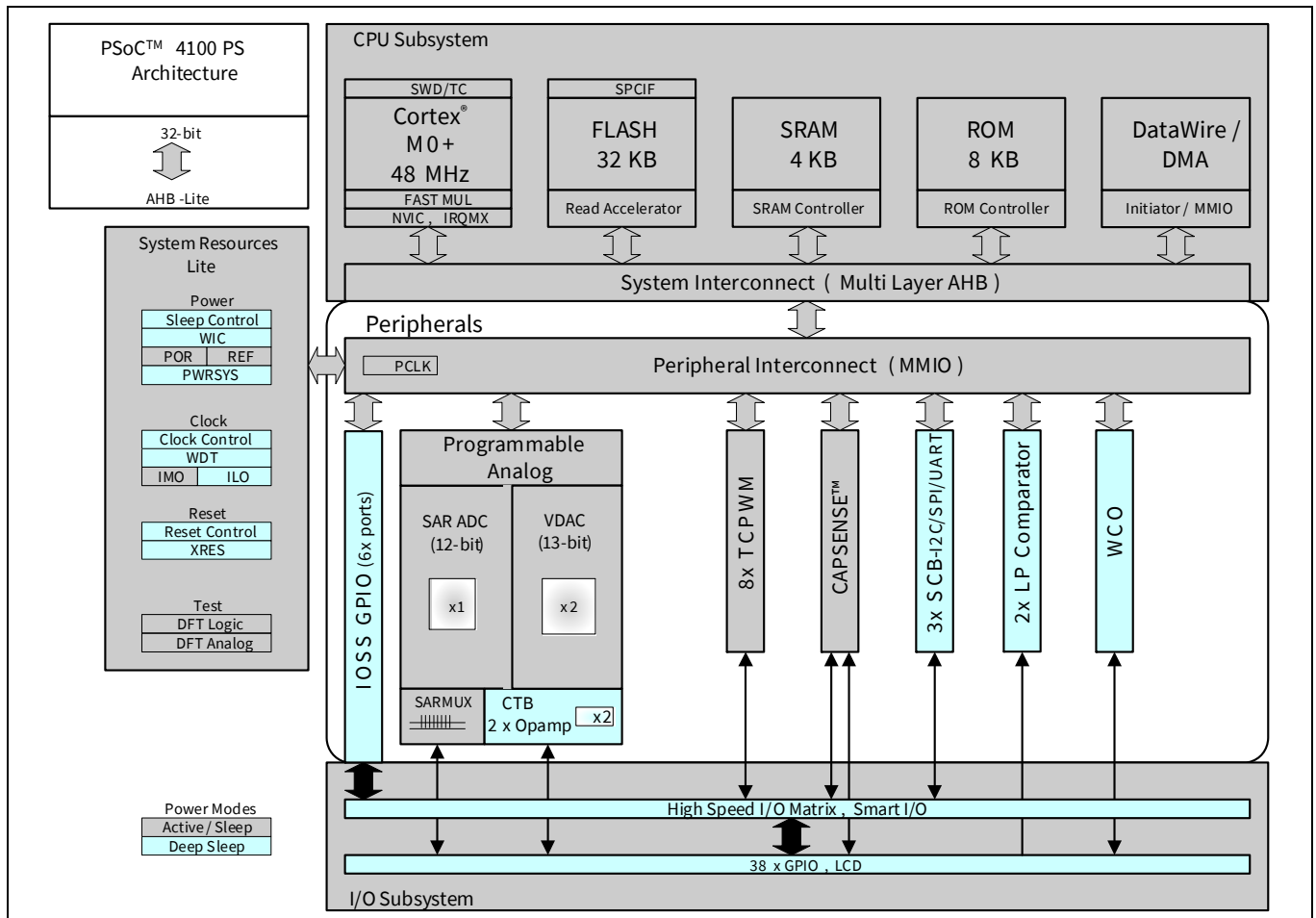

**Figure 2 Block diagram**

PSoC™ 4100PS devices include extensive support for programming, testing, debugging, and tracing both hardware and firmware.

The Arm® Serial-Wire Debug (SWD) interface supports all programming and debug features of the device.

Complete debug-on-chip functionality enables full-device debugging in the final system using the standard production device. It does not require special interfaces, debugging pods, simulators, or emulators. Only the standard programming connections are required to fully support debug.

The PSoC™ Creator IDE provides fully integrated programming and debug support for the PSoC™ 4100PS devices. The SWD interface is fully compatible with industry-standard third-party tools. The PSoC™ 4100PS family provides a level of security not possible with multi-chip application solutions or with microcontrollers. It has the following advantages:

- Allows disabling of debug features
- Robust flash protection
- Allows customer-proprietary functionality to be implemented in on-chip programmable blocks

The debug circuits are enabled by default and can be disabled in firmware. If they are not enabled, the only way to re-enable them is to erase the entire device, clear flash protection, and reprogram the device with new firmware that enables debugging. Thus firmware control of debugging cannot be over-ridden without erasing the firmware thus providing security.

Additionally, all device interfaces can be permanently disabled (device security) for applications concerned about phishing attacks due to a maliciously reprogrammed device or attempts to defeat security by starting and interrupting flash programming sequences. All programming, debug, and test interfaces are disabled when maximum device security is enabled. Therefore, PSoC™ 4100PS, with device security enabled, may not be returned for failure analysis. This is a trade-off the PSoC™ 4100PS allows the customer to make.

## **2 Functional definition**

### **2.1 CPU and memory subsystem**

#### **2.1.1 CPU**

The Cortex®-M0+ CPU in the PSoC™ 4100PS is part of the 32-bit MCU subsystem, which is optimized for low-power operation with extensive clock gating. Most instructions are 16 bits in length and the CPU executes a subset of the Thumb-2 instruction set. It includes a nested vectored interrupt controller (NVIC) block with eight interrupt inputs and also includes a Wakeup Interrupt Controller (WIC). The WIC can wake the processor from Deep Sleep mode, allowing power to be switched off to the main processor when the chip is in Deep Sleep mode.

The CPU also includes a debug interface, the serial wire debug (SWD) interface, which is a two-wire form of JTAG. The debug configuration used for PSoC™ 4100PS has four breakpoint (address) comparators and two watchpoint (data) comparators.

#### **2.1.2 DMA/DataWire**

The DMA engine will be capable of doing independent data transfers anywhere within the memory map via a user-programmable descriptor chain. The DataWire capability is used to effect single-element transfers from one location in memory to another. There are eight DMA channels with a range of selectable trigger sources.

#### **2.1.3 Flash**

The PSoC™ 4100PS device has a flash module with a flash accelerator, tightly coupled to the CPU to improve average access times from the flash block. The low-power flash block is designed to deliver two wait-state (WS) access time at 48 MHz. The flash accelerator delivers 85% of single-cycle SRAM access performance on average.

#### **2.1.4 SRAM**

Four KB of SRAM are provided with zero wait-state access at 48 MHz.

#### **2.1.5 SROM**

Eight KB of SROM are provided that contain boot and configuration routines.

## 2.2 System resources

### 2.2.1 Power system

The power system is described in detail in the section “**Power**” on page 21. It provides an assurance that voltage levels are as required for each respective mode and either delays mode entry (for example, on power-on reset (POR) until voltage levels are as required for proper functionality, or generates resets (for example, on brown-out detection). PSoC™ 4100PS operates with a single external supply over the range of either 1.8 V ± 5% (externally regulated) or 1.8 V to 5.5 V (internally regulated) and has three different power modes, transitions between which are managed by the power system. PSoC™ 4100PS provides Active, Sleep, and Deep Sleep low-power modes.

All subsystems are operational in Active mode. The CPU subsystem (CPU, flash, and SRAM) is clock-gated off in Sleep mode, while all peripherals and interrupts are active with instantaneous wake-up on a wake-up event. In Deep Sleep mode, the high-speed clock and associated circuitry is switched off; wake-up from this mode takes 35 µs. The opamps can remain operational in Deep Sleep mode.

### 2.2.2 Clock system

The PSoC™ 4100PS clock system is responsible for providing clocks to all subsystems that require clocks and for switching between different clock sources without glitching. In addition, the clock system ensures that there are no metastable conditions.

The clock system for the PSoC™ 4100PS consists of the internal main oscillator (IMO), internal low-frequency oscillator (ILO), a 32 kHz Watch Crystal Oscillator (WCO) and provision for an external clock. Clock dividers are provided to generate clocks for peripherals on a fine-grained basis. Fractional dividers are also provided to enable clocking of higher data rates for UARTs.

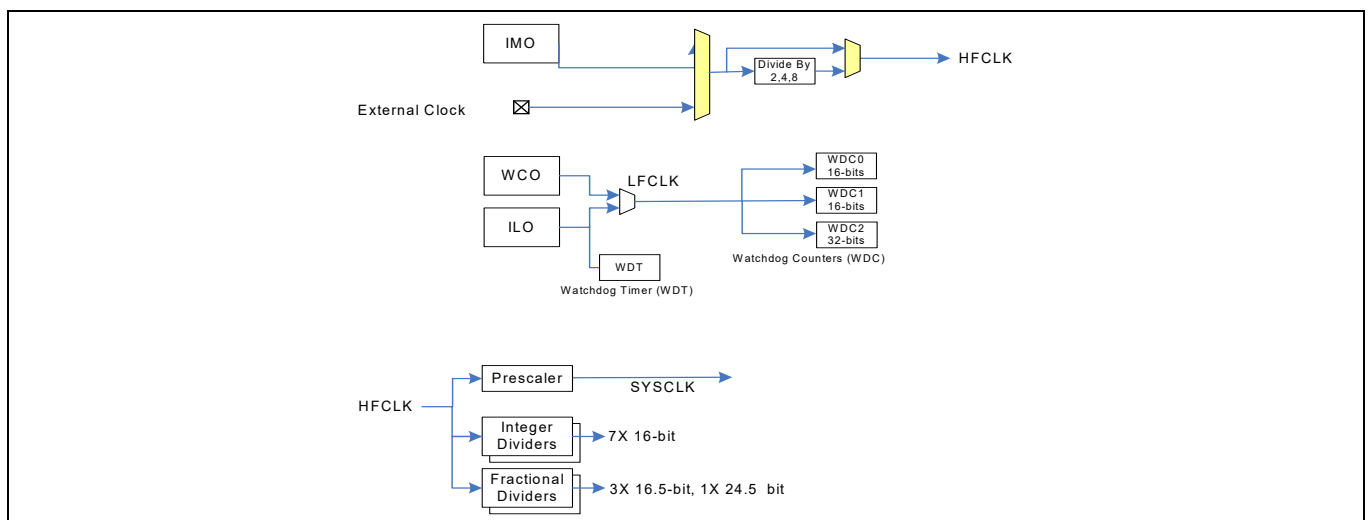

**Figure 3 PSoC™ 4100PS MCU Clocking Architecture**

The HFCLK signal can be divided down to generate synchronous clocks for the analog and digital peripherals. There are 11 clock dividers for PSoC™ 4100PS as shown in the diagram above. The 16-bit capability allows flexible generation of fine-grained frequency values (there is one 24-bit divider for large divide ratios), and is fully supported in PSoC™ Creator.

### 2.2.3 IMO clock source

The IMO is the primary source of internal clocking in PSoC™ 4100PS. It is trimmed during testing to achieve the specified accuracy. The IMO default frequency is 24 MHz and it can be adjusted from 24 to 48 MHz in steps of 4 MHz. The IMO tolerance with Infineon-provided calibration settings is ±2%.

### **2.2.4 ILO clock source**

The ILO is a very low power, nominally 40-kHz oscillator, which is primarily used to generate clocks for the watchdog timer (WDT) and peripheral operation in Deep Sleep mode. ILO-driven counters can be calibrated to the IMO to improve accuracy. Infineon provides a software component, which does the calibration.

### **2.2.5 Watch crystal oscillator (WCO)**

The PSoC™ 4100PS clock subsystem also implements a low-frequency (32-kHz watch crystal) oscillator that can be used for Watchdog timing applications.

### **2.2.6 Watchdog timer**

A watchdog timer is implemented in the clock block running from the ILO; this allows watchdog operation during Deep Sleep and generates a watchdog reset if not serviced before the set timeout occurs. The watchdog reset is recorded in a Reset Cause register, which is firmware readable.

### **2.2.7 Reset**

PSoC™ 4100PS can be reset from a variety of sources including a software reset. Reset events are asynchronous and guarantee reversion to a known state. The reset cause is recorded in a register, which is sticky through reset and allows software to determine the cause of the reset. An XRES pin is reserved for external reset by asserting it active low. The XRES pin has an internal pull-up resistor that is always enabled.

### **2.2.8 Voltage reference**

The PSoC™ 4100PS reference system generates all internally required references. A 1.2-V voltage reference is provided for the comparator. The IDACs are based on a  $\pm 5\%$  reference.

## 2.3 Analog blocks

### 2.3.1 12-bit SAR ADC

The 12-bit, 1-Msps SAR ADC can operate at a maximum clock rate of 18 MHz and requires a minimum of 18 clocks at that frequency to do a 12-bit conversion.

The Sample-and-Hold (S/H) aperture is programmable allowing the gain bandwidth requirements of the amplifier driving the SAR inputs, which determine its settling time, to be relaxed if required. It is possible to provide an external bypass (through a fixed pin location) for the internal reference amplifier.

The SAR is connected to a fixed set of pins through an 8-input sequencer. The sequencer cycles through selected channels autonomously (sequencer scan) with zero switching overhead (that is, aggregate sampling bandwidth is equal to 1 Msps whether it is for a single channel or distributed over several channels). The sequencer switching is effected through a state machine or through firmware driven switching. A feature provided by the sequencer is buffering of each channel to reduce CPU interrupt service requirements. To accommodate signals with varying source impedance and frequency, it is possible to have different sample times programmable for each channel. Also, signal range specification through a pair of range registers (low and high range values) is implemented with a corresponding out-of-range interrupt if the digitized value exceeds the programmed range; this allows fast detection of out-of-range values without the necessity of having to wait for a sequencer scan to be completed and the CPU to read the values and check for out-of-range values in software.

The SAR is not available in Deep Sleep mode as it requires a high-speed clock (up to 18 MHz). The SAR operating range is 1.71 V to 5.5 V.

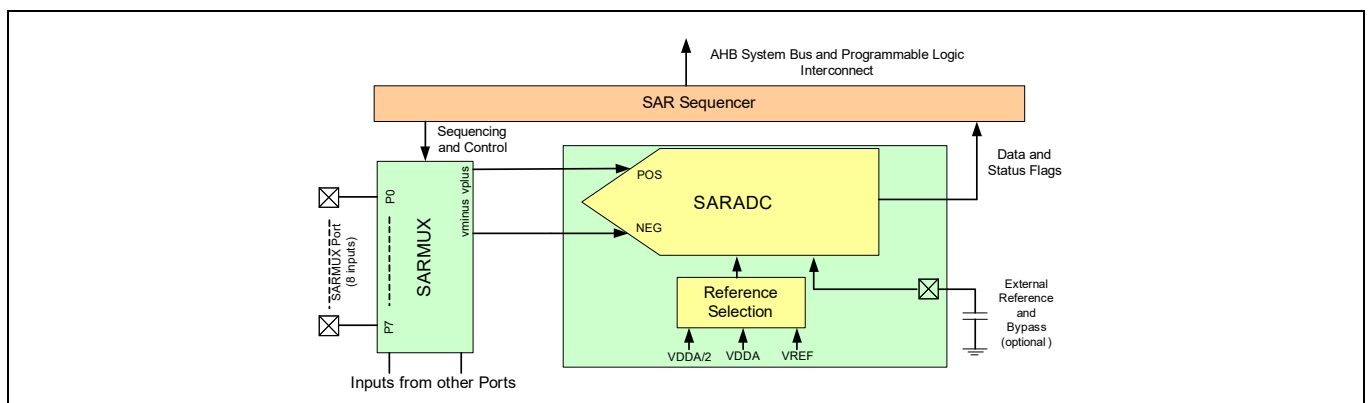

**Figure 4 SAR ADC**

### 2.3.2 Four opamps (Continuous-time block; CTB)

PSoC™ 4100PS has four opamps with Comparator modes which allow most common analog functions to be performed on-chip eliminating external components; PGAs, Voltage Buffers, Filters, Trans-Impedance Amplifiers, and other functions can be realized, in some cases with external passives, saving power, cost, and space. The on-chip opamps are designed with enough bandwidth to drive the Sample-and-Hold circuit of the ADC without requiring external buffering.

### **2.3.3 VDAC (13 bits)**

The PSoC™ 4100PS has two 13-bit resolution Voltage DACs.

### **2.3.4 Low-power comparators (LPC)**

PSoC™ 4100PS has a pair of low-power comparators, which can also operate in Deep Sleep modes. This allows the analog system blocks to be disabled while retaining the ability to monitor external voltage levels during low-power modes. The comparator outputs are normally synchronized to avoid metastability unless operating in an asynchronous power mode where the system wake-up circuit is activated by a comparator switch event. The LPC outputs can be routed to pins.

### **2.3.5 Current DACs**

PSoC™ 4100PS has two IDACs, which can drive any of the pins on the chip. These IDACs have programmable current ranges.

### **2.3.6 Analog multiplexed buses**

PSoC™ 4100PS has two concentric independent buses that go around the periphery of the chip. These buses (called amux buses) are connected to firmware-programmable analog switches that allow the chip's internal resources (IDACs, comparator) to connect to any pin on the I/O ports.

### **2.3.7 Temperature sensor**

There is an on-chip temperature sensor which is calibrated during production to achieve  $\pm 1\%$  typical ( $\pm 5\%$  maximum) deviation from accuracy. The SAR ADC is used to measure the temperature.

## **2.4 Fixed Function Digital**

### **2.4.1 Timer/Counter/PWM (TCPWM) block**

The TCPWM block consists of a 16-bit counter with user-programmable period length. There is a capture register to record the count value at the time of an event (which may be an I/O event), a period register that is used to either stop or auto-reload the counter when its count is equal to the period register, and compare registers to generate compare value signals that are used as PWM duty cycle outputs. The block also provides true and complementary outputs with programmable offset between them to allow use as dead-band programmable complementary PWM outputs. It also has a Kill input to force outputs to a predetermined state; for example, this is used in motor drive systems when an over-current state is indicated and the PWM driving the FETs needs to be shut off immediately with no time for software intervention. There are eight TCPWM blocks in PSoC™ 4100PS.

## 2.4.2 Serial Communication block (SCB)

PSoC™ 4100PS has three serial communication blocks, which can be programmed to have SPI, I<sup>2</sup>C, or UART functionality.

**I<sup>2</sup>C Mode:** The hardware I<sup>2</sup>C block implements a full multi-master and slave interface (it is capable of multi-master arbitration). This block is capable of operating at speeds of up to 1 Mbps (Fast Mode Plus) and has flexible buffering options to reduce interrupt overhead and latency for the CPU. It also supports EZI2C that creates a mailbox address range in the memory of PSoC™ 4100PS and effectively reduces I<sup>2</sup>C communication to reading from and writing to an array in memory. In addition, the block supports an 8-deep FIFO for receive and transmit which, by increasing the time given for the CPU to read data, greatly reduces the need for clock stretching caused by the CPU not having read data on time.

The I<sup>2</sup>C peripheral is compatible with the I<sup>2</sup>C Standard-mode and Fast-mode devices as defined in the NXP I<sup>2</sup>C-bus specification and user manual (UM10204). The I<sup>2</sup>C bus I/O is implemented with GPIO in open-drain modes.

PSoC™ 4100PS is not completely compliant with the I<sup>2</sup>C spec in the following respect:

- GPIO cells are not overvoltage tolerant and, therefore, cannot be hot-swapped or powered up independently of the rest of the I<sup>2</sup>C system.

**UART Mode:** This is a full-feature UART operating at up to 1 Mbps. It supports automotive single-wire interface (LIN), infrared interface (IrDA), and SmartCard (ISO7816) protocols, all of which are minor variants of the basic UART protocol. In addition, it supports the 9-bit multiprocessor mode that allows addressing of peripherals connected over common RX and TX lines. Common UART functions such as parity error, break detect, and frame error are supported. An 8-deep FIFO allows much greater CPU service latencies to be tolerated.

**SPI Mode:** The SPI mode supports full Motorola SPI, TI SSP (adds a start pulse used to synchronize SPI Codecs), and National Microwire (half-duplex form of SPI). The SPI block can use the FIFO.

## 2.5 GPIO

PSoC™ 4100PS has up to 38 GPIOs. The GPIO block implements the following:

- Eight drive modes:
  - Analog input mode (input and output buffers disabled)
  - Input only
  - Weak pull-up with strong pull-down
  - Strong pull-up with weak pull-down
  - Open drain with strong pull-down
  - Open drain with strong pull-up
  - Strong pull-up with strong pull-down
  - Weak pull-up with weak pull-down
- Input threshold select (CMOS or LVTTTL)
- Individual control of input and output buffer enabling/disabling in addition to the drive strength modes
- Selectable slew rates for dV/dt related noise control to improve EMI.

The pins are organized in logical entities called ports, which are 8-bit in width (less for Ports 2 and 3). During power-on and reset, the blocks are forced to the disable state so as not to crowbar any inputs and/or cause excess turn-on current. A multiplexing network known as a high-speed I/O matrix is used to multiplex between various signals that may connect to an I/O pin.

Data output and pin state registers store, respectively, the values to be driven on the pins and the states of the pins themselves.

Every I/O pin can generate an interrupt if so enabled; each I/O port has an interrupt request (IRQ) and interrupt service routine (ISR) vector associated with it (4 for PSoC™ 4100PS). The Smart I/O block is a fabric of switches and LUTs that allows Boolean functions to be performed on signals being routed to the pins of a GPIO port. The Smart I/O block can perform logical operations on input pins to the chip and on signals going out as outputs.

## **2.6 Special Function Peripherals**

### **2.6.1 CAPSENSE™**

CAPSENSE™ is supported in PSoC™ 4100PS through a CSD block that can be connected to any pins through an analog mux bus via an analog switch. CAPSENSE™ function can thus be provided on any available pin or group of pins in a system under software control. A PSoC™ Creator component is provided for the CAPSENSE™ block to make it easy for the user.

Shield voltage can be driven on another mux bus to provide water-tolerance capability. Water tolerance is provided by driving the shield electrode in phase with the sense electrode to keep the shield capacitance from attenuating the sensed input. Proximity sensing can also be implemented.

The CAPSENSE™ block has two IDACs, which can be used for general purposes if CAPSENSE™ is not being used (both IDACs are available in that case) or if CAPSENSE™ is used without water tolerance (one IDAC is available). The CAPSENSE™ block also provides a 10-bit Slope ADC function, which can be used in conjunction with the CAPSENSE™ function.

The CAPSENSE™ block is an advanced, low-noise, programmable block with programmable voltage references and current source ranges for improved sensitivity and flexibility. It can also use an external reference voltage. It has a full-wave CSD mode that alternates sensing to VDDA and ground to null out power-supply related noise

## **2.7 WLCSP Package Bootloader**

The WLCSP package is supplied with an I<sup>2</sup>C bootloader installed in flash. The bootloader is compatible with PSoC™ Creator bootloader project files.

### 3 Pinouts

The following table provides the pin list for PSoC™ 4100PS for the 48-pin QFN, 48-pin TQFP, 45-ball WLCSP, and 28-pin SSOP packages. All port pins support GPIO.

**Table 1 Pinouts**

Packages							
48-pin QFN		48-pin TQFP		28-pin SSOP		45-ball CSP	
Pin	Name	Pin	Name	Pin	Name	Pin	Name
28	P0.0	28	P0.0	21	P0.0	D3	P0.0
29	P0.1	29	P0.1	22	P0.1	E2	P0.1
30	P0.2	30	P0.2	23	P0.2	D2	P0.2
31	P0.3	31	P0.3			C3	P0.3
32	P0.4	32	P0.4			D1	P0.4
33	P0.5	33	P0.5			E1	P0.5
34	P0.6	34	P0.6			C2	P0.6
35	P0.7	35	P0.7			B2	P0.7
36	XRES	36	XRES	24	XRES	B3	XRES
37	P4.0	37	P4.0			A1	P4.0
38	P4.1	38	P4.1			B1	P4.1
39	P5.0	39	P5.0	25	P5.0	B4	P5.0
40	P5.1	40	P5.1			C1	P5.1
41	P5.2	41	P5.2	26	P5.2	A2	P5.2
42	P5.3	42	P5.3	27	P5.3	A3	P5.3
43	VDDA	43	VDDA	28	VDDA	J2	VDDA
44	VSSA	44	VSSA			J3	VSSA
45	VCCD	45	VCCD	1	VCCD	A4	VCCD
						B5	VDDD
46	VSSD	46	VSSD	2	VSSD	A5	VSSD
47	VDDD	47	VDDD	3	VDDD		
48	P1.0	48	P1.0	4	P1.0	C5	P1.0
1	P1.1	1	P1.1	5	P1.1	C4	P1.1
2	P1.2	2	P1.2	6	P1.2	D5	P1.2
3	P1.3	3	P1.3	7	P1.3	D4	P1.3
4	P1.4	4	P1.4			E3	P1.4
5	P1.5	5	P1.5			E4	P1.5
6	P1.6	6	P1.6				
7	P1.7	7	P1.7			G3	P1.7
8	VDDA	8	VDDA	8	VDDA	E5	VDDA
9	VSSA	9	VSSA	9	VSSA	F5	VSSA
10	P2.0	10	P2.0	10	P2.0	F4	P2.0
11	P2.1	11	P2.1	11	P2.1	F3	P2.1

**Table 1** Pinouts (continued)

Packages							
48-pin QFN		48-pin TQFP		28-pin SSOP		45-ball CSP	
Pin	Name	Pin	Name	Pin	Name	Pin	Name
12	P2.2	12	P2.2	12	P2.2	G4	P2.2
13	P2.3	13	P2.3	13	P2.3	G5	P2.3
14	P2.4	14	P2.4			H5	P2.4
15	P2.5	15	P2.5			J4	P2.5
16	P2.6	16	P2.6			H4	P2.6
17	P2.7/VREF	17	P2.7/VREF	14	P2.7/VREF	J5	P2.7/VREF
18	VSSA	18	VSSA			J3	VSSA
19	VDDA	19	VDDA	15	VDDA	J2	VDDA
20	P3.0	20	P3.0			H2	P3.0
21	P3.1	21	P3.1	16	P3.1	F2	P3.1
22	P3.2	22	P3.2	17	P3.2	J1	P3.2
23	P3.3	23	P3.3	18	P3.3	H3	P3.3
24	P3.4	24	P3.4			F1	P3.4
25	P3.5	25	P3.5			G2	P3.5
26	P3.6	26	P3.6	19	P3.6	G1	P3.6
27	P3.7	27	P3.7	20	P3.7	H1	P3.7

**Descriptions of the Power pins are as follows:**

VDDD: Power supply for the digital section.

VDDA: Power supply for the analog section.

VSS: Ground pin.

VCCD: Regulated digital supply (1.8 V ± 5%)

The 48-pin packages have 38 I/O pins. The 45-ball CSP and the 28-pin SSOP have 37 and 20 I/O pins respectively.

### 3.1 Alternate pin functions

Each Port pin has can be assigned to one of multiple functions; it can, for example, be an Analog I/O, a Digital Peripheral pin. The pin assignments are shown in the following table.

**Table 2** Alternate pin functions

Port/Pin	Analog	SmartIO	Active				De
			ACT #0	ACT #1	ACT #2	ACT #3	
P0.0		SmartIO[0].io[0]	tcpwm.line[4]:1			tcpwm.tr_in[0]	cp
P0.1		SmartIO[0].io[1]	tcpwm.line_compl[4]:1			tcpwm.tr_in[1]	cp
P0.2		SmartIO[0].io[2]	tcpwm.line[5]:1		srss.ext_clk		
P0.3		SmartIO[0].io[3]	tcpwm.line_compl[5]:1				
P0.4		SmartIO[0].io[4]	tcpwm.line[6]:1	scb[1].uart_rx:0			sc
P0.5		SmartIO[0].io[5]	tcpwm.line_compl[6]:1	scb[1].uart_tx:0			sc
P0.6		SmartIO[0].io[6]		scb[1].uart_cts:0			lp
P0.7		SmartIO[0].io[7]		scb[1].uart_rts:0			lp
P4.0	wco_in		tcpwm.line[0]:2	scb[2].uart_rx:1		tcpwm.tr_in[5]	sc
P4.1	wco_out		tcpwm.line_compl[0]:2	scb[2].uart_tx:1		tcpwm.tr_in[6]	sc
P5.0	csd.cshieldpads		tcpwm.line[7]:1	scb[0].uart_rx:1			sc
P5.1	csd.vref_ext		tcpwm.line_compl[7]:1	scb[0].uart_tx:1			sc
P5.2	csd.dsi_cmod		tcpwm.line[6]:2	scb[0].uart_cts:1	tr_sar_out		

**Table 2** Alternate pin functions (continued)

Port/Pin	Analog	SmartIO	Active			De
			ACT #0	ACT #1	ACT #2	
P5.3	csd.dsi_csh_tank		tcpwm.line_compl[6]:2	scb[0].uart_rts:1		
P1.0	ctb_pads[8] lpcomp.in_p[1]		tcpwm.line[0]:1	scb[1].uart_rx:1		sc
P1.1	ctb_pads[9] lpcomp.in_n[1]		tcpwm.line_compl[0]:1	scb[1].uart_tx:1		sc
P1.2	ctb_pads[10] ctb_oa0_out_10x[1]		tcpwm.line[1]:1	scb[1].uart_cts:1		
P1.3	ctb_pads[11] ctb_oa1_out_10x[1]		tcpwm.line_compl[1]:1	scb[1].uart_rts:1		
P1.4	ctb_pads[12]		tcpwm.line[2]:1			
P1.5	ctb_pads[13]		tcpwm.line_compl[2]:1			
P1.6	ctb_pads[14]		tcpwm.line[3]:1			
P1.7	ctb_pads[15]		tcpwm.line_compl[3]:1			
P2.0	ctb_pads[0]		tcpwm.line[4]:0	scb[2].uart_rx:0		sc
P2.1	ctb_pads[1]		tcpwm.line_compl[4]:0	scb[2].uart_tx:0		sc
P2.2	ctb_pads[2] ctb_oa0_out_10x[0]		tcpwm.line[5]:0	scb[2].uart_cts:0		
P2.3	ctb_pads[3] ctb_oa1_out_10x[0]		tcpwm.line_compl[5]:0	scb[2].uart_rts:0		
P2.4	ctb_pads[4]		tcpwm.line[0]:0			

**Table 2** Alternate pin functions (continued)

Port/Pin	Analog	SmartIO	Active			DS
			ACT #0	ACT #1	ACT #2	
P2.5	ctb_pads[5]		tcpwm.line_compl[0]:0			
P2.6	ctb_pads[6]		tcpwm.line[1]:0			
P2.7	ctb_pads[7]		tcpwm.line_compl[1]:0			
P3.0	sar_ext_vref0 sar_ext_vref1					
P3.1	sarmux[0]		tcpwm.line[2]:0	scb[0].uart_rx:0		sc
P3.2	sarmux[1]		tcpwm.line_compl[2]:0	scb[0].uart_tx:0		sc
P3.3	sarmux[2] lpcomp.in_p[0]		tcpwm.line[3]:0	scb[0].uart_cts:0		
P3.4	sarmux[3] lpcomp.in_n[0]		tcpwm.line_compl[3]:0	scb[0].uart_rts:0		
P3.5	sarmux[4]		tcpwm.line[6]:0			tcpwm.tr_in[2]
P3.6	sarmux[5]		tcpwm.line_compl[6]:0			tcpwm.tr_in[3]
P3.7	sarmux[6]		tcpwm.line[7]:0	scb[2].uart_rx:2		tcpwm.tr_in[4]
P3.7	sarmux[7]		tcpwm.line_compl[7]:0	scb[2].uart_tx:2		sc

Refer to the Technical Reference Manual (TRM) for CTB connection details. The VDAC outputs are buffered through the may be routed to any CTB output.

## 4 Power

The following power system diagram shows the set of power supply pins as implemented for the PSoC™ 4100PS. The system has one regulator in Active mode for the digital circuitry. There is no analog regulator; the analog circuits run directly from the  $V_{DDA}$  input.

**Note that VDDD and VDDA must be shorted together on the PCB.**

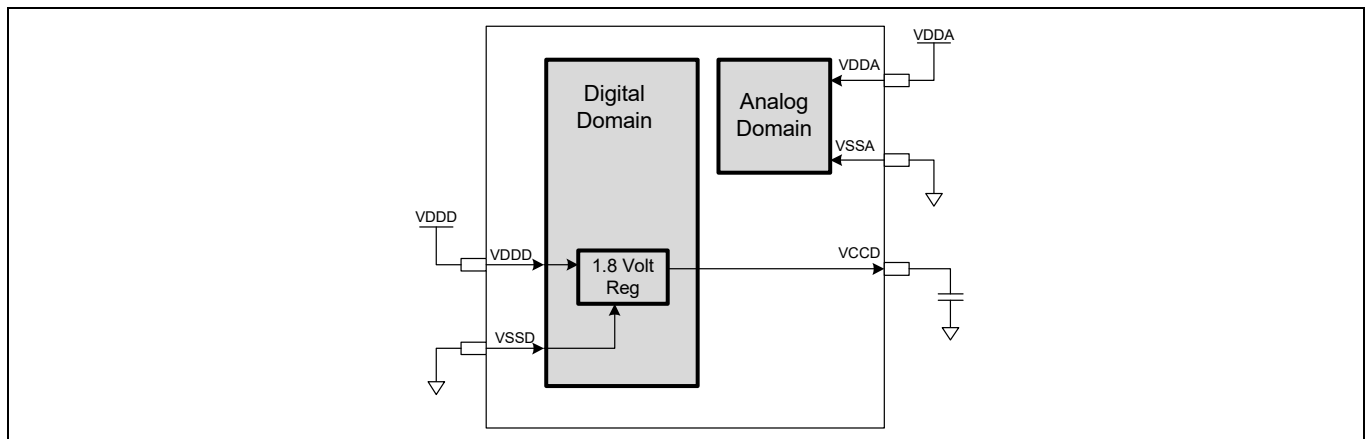

**Figure 5 Power supply connections**

There are two distinct modes of operation. In Mode 1, the supply voltage range is 1.8 V to 5.5 V (unregulated externally; internal regulator operational). In Mode 2, the supply range is 1.8 V  $\pm$  5% (externally regulated; 1.71 V to 1.89 V, internal regulator bypassed).

### 4.1 Mode 1: 1.8 V to 5.5 V External Supply

In this mode, the PSoC™ 4100PS is powered by an external power supply that can be anywhere in the range of 1.8 V to 5.5 V. This range is also designed for battery-powered operation. For example, the chip can be powered from a battery system that starts at 3.5 V and works down to 1.8 V. In this mode, the internal regulator of the PSoC™ 4100PS supplies the internal logic and its output is connected to the  $V_{CCD}$  pin. The  $V_{CCD}$  pin must be bypassed to ground via an external capacitor (0.1  $\mu$ F; X5R ceramic or better) and must not be connected to anything else.

## 4.2 Mode 2: 1.8 V ± 5% External Supply

In this mode, the PSoC™ 4100PS is powered by an external power supply that must be within the range of 1.71 V to 1.89 V; note that this range needs to include the power supply ripple too. In this mode, the  $V_{DDD}$  and  $V_{CCD}$  pins are shorted together and bypassed.

Bypass capacitors must be used from  $V_{DDD}$  and  $V_{DDA}$  to ground. The typical practice for systems in this frequency range is to use a capacitor in the 1- $\mu\text{F}$  range, in parallel with a smaller capacitor (0.1  $\mu\text{F}$ , for example). Note that these are simply rules of thumb and that, for critical applications, the PCB layout, lead inductance, and the bypass capacitor parasitic should be simulated to design and obtain optimal bypassing.

Figure 6 shows an example of a bypass scheme.

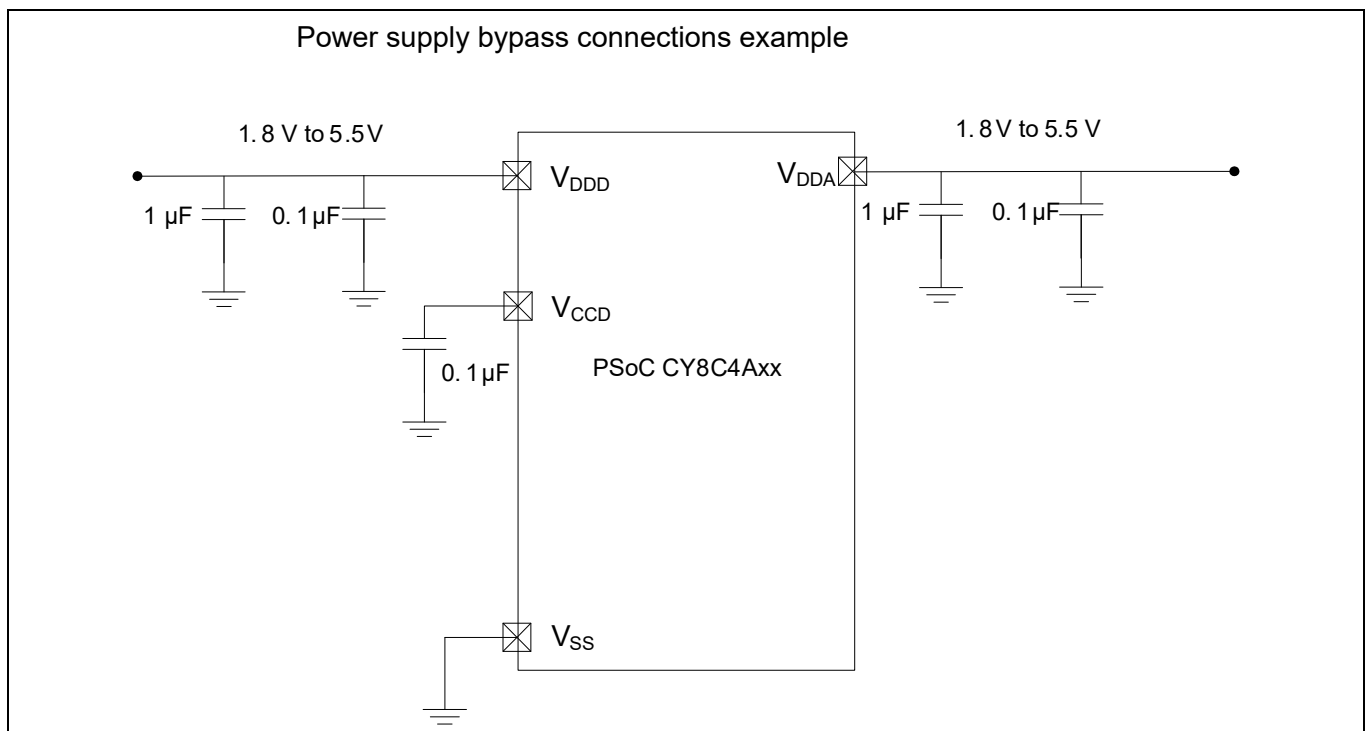

Figure 6 External supply range from 1.8 V to 5.5 V with Internal Regulator Active

## 5 Development support

The PSoC™ 4100PS family has a rich set of documentation, development tools, and online resources to assist you during your development process. Visit [www.infineon.com/psoc4](http://www.infineon.com/psoc4) to find out more.

### 5.1 Documentation

A suite of documentation supports the PSoC™ 4100PS family to ensure that you can find answers to your questions quickly. This section contains a list of some of the key documents.

**Software user guide:** A step-by-step guide for using PSoC™ Creator. The software user guide shows you how the PSoC™ Creator build process works in detail, how to use source control with PSoC™ Creator, and much more.

**Component datasheets:** The flexibility of PSoC™ allows the creation of new peripherals (components) long after the device has gone into production. Component data sheets provide all of the information needed to select and use a particular component, including a functional description, API documentation, example code, and AC/DC specifications.

**Application notes:** PSoC™ application notes discuss a particular application of PSoC™ in depth; examples include brushless DC motor control and on-chip filtering. Application notes often include example projects in addition to the application note document.

**Technical reference manual:** The Technical Reference Manual (TRM) contains all the technical detail you need to use a PSoC™ device, including a complete description of all PSoC™ registers. The TRM is available in the Documentation section at [www.infineon.com/psoc4](http://www.infineon.com/psoc4).

### 5.2 Online

In addition to print documentation, the Infineon PSoC™ forums connect you with fellow PSoC™ users and experts in PSoC™ from around the world, 24 hours a day, 7 days a week.

### 5.3 Tools

With industry standard cores, programming, and debugging interfaces, the PSoC™ 4100PS family is part of a development tool ecosystem. Visit us at [www.infineon.com/psoccreator](http://www.infineon.com/psoccreator) for the latest information on the revolutionary, easy to use PSoC™ Creator IDE, supported third party compilers, programmers, debuggers, and development kits.

## 6 Electrical specifications

### 6.1 Absolute maximum ratings

**Table 3** Absolute maximum ratings<sup>[1]</sup>

Spec ID#	Parameter	Description	Min	Typ	Max	Unit	Details/ conditions
SID1	V <sub>DD_ABS</sub>	Digital or Analog supply relative to V <sub>SS</sub>	-0.5	-	6	V	V <sub>DDD</sub> , V <sub>DDA</sub> , Absolute Max
SID2	V <sub>CCD_ABS</sub>	Direct digital core voltage input relative to V <sub>SS</sub>	-0.5	-	1.95		-
SID3	V <sub>GPIO_ABS</sub>	GPIO voltage	-0.5	-	V <sub>DD</sub> + 0.5		-
SID4	I <sub>GPIO_ABS</sub>	Maximum current per GPIO	-25	-	25	mA	-
SID5	I <sub>GPIO_injection</sub>	GPIO injection current, Max for V <sub>IH</sub> > V <sub>DDD</sub> , and Min for V <sub>IL</sub> < V <sub>SS</sub>	-0.5	-	0.5		Current injected per pin
BID44	ESD_HBM	Electrostatic discharge human body model	2200	-	-	V	-
BID45	ESD_CDM	Electrostatic discharge charged device model	500	-	-		-
BID46	LU	Pin current for latch-up	-140	-	140	mA	-

#### Note

- Usage above the absolute maximum conditions listed in **Table 3** may cause permanent damage to the device. Exposure to Absolute Maximum conditions for extended periods of time may affect device reliability. The Maximum Storage Temperature is 150°C in compliance with JEDEC Standard JESD22-A103, High Temperature Storage Life. When used below Absolute Maximum conditions but above normal operating conditions, the device may not operate to specification.

## 6.2 Device Level Specifications

All specifications are valid for  $-40^{\circ}\text{C} \leq T_A \leq 105^{\circ}\text{C}$  and  $T_J \leq 125^{\circ}\text{C}$ , except where noted. Specifications are valid for 1.71 V to 5.5 V, except where noted.

**Table 4 DC specifications**

Typical values measured at  $V_{DD} = 3.3\text{ V}$  and  $25^{\circ}\text{C}$ .

Spec ID#	Parameter	Description	Min	Typ	Max	Unit	Details/ conditions
SID53	$V_{DD}$	Power supply input voltage	1.8	–	5.5	V	With regulator enabled
SID255	$V_{DD}$	Power supply input voltage ( $V_{CCD} = V_{DD}$ )	1.71	–	1.89		Internally unregulated supply
SID54	$V_{DDIO}$	$V_{DDIO}$ domain supply	1.71	–	$V_{DD}$		–
SID55	$C_{EFC}$	External regulator voltage bypass	–	0.1	–	$\mu\text{F}$	X5R ceramic or better
SID56	$C_{EXC}$	Power supply bypass capacitor	–	1	–		X5R ceramic or better

**Active Mode,  $V_{DD} = 1.8\text{ V}$  to  $5.5\text{ V}$ . Typical values measured at  $V_{DD} = 3.3\text{ V}$  and  $25^{\circ}\text{C}$ .**

SID10	$I_{DD5}$	Execute from flash; CPU at 6 MHz	–	2	–	mA	–
SID16	$I_{DD8}$	Execute from flash; CPU at 24 MHz	–	5.6	–		–
SID19	$I_{DD11}$	Execute from flash; CPU at 48 MHz	–	10.4	–		–

**Sleep Mode,  $V_{DDD} = 1.8\text{ V}$  to  $5.5\text{ V}$  (Regulator on)**

SID22	$I_{DD17}$	$I^2\text{C}$ wakeup WDT, and Comparators on.	–	1.1	–	mA	6 MHz
SID25	$I_{DD20}$	$I^2\text{C}$ wakeup, WDT, and Comparators on.	–	3.1	–		12 MHz

**Sleep Mode,  $V_{DDD} = 1.71\text{ V}$  to  $1.89\text{ V}$  (Regulator bypassed)**

SID28	$I_{DD23}$	$I^2\text{C}$ wakeup, WDT, and Comparators on.	–	1.1	–	mA	6 MHz
SID28A	$I_{DD23A}$	$I^2\text{C}$ wakeup, WDT, and Comparators on.	–	3.1	–	mA	12 MHz

**Deep Sleep Mode,  $V_{DD} = 1.8\text{ V}$  to  $3.6\text{ V}$  (Regulator on)**

SID31	$I_{DD26}$	$I^2\text{C}$ wakeup and WDT on	–	2.5	–	$\mu\text{A}$	–
-------	------------	---------------------------------	---	-----	---	---------------	---

**Deep Sleep Mode,  $V_{DD} = 3.6\text{ V}$  to  $5.5\text{ V}$  (Regulator on)**

SID34	$I_{DD29}$	$I^2\text{C}$ wakeup and WDT on	–	2.5	–	$\mu\text{A}$	–
-------	------------	---------------------------------	---	-----	---	---------------	---

**Deep Sleep Mode,  $V_{DD} = 1.71\text{ V}$  to  $1.89\text{ V}$  (Regulator bypassed)**

SID37	$I_{DD32}$	$I^2\text{C}$ wakeup and WDT on	–	2.5	–	$\mu\text{A}$	–
-------	------------	---------------------------------	---	-----	---	---------------	---

**XRES Current**

SID307	$I_{DD\_XR}$	Supply current while XRES asserted	–	115	300	$\mu\text{A}$	–
--------	--------------	------------------------------------	---	-----	-----	---------------	---

**Table 5 AC specifications**

Spec ID#	Parameter	Description	Min	Typ	Max	Unit	Details/conditions
SID48	F <sub>CPU</sub>	CPU frequency	DC	–	48	MHz	1.71 ≤ V <sub>DD</sub> ≤ 5.5
SID49 <sup>[2]</sup>	T <sub>SLEEP</sub>	Wakeup from Sleep mode	–	0	–	μs	–
SID50 <sup>[2]</sup>	T <sub>DEEPSLEEP</sub>	Wakeup from Deep Sleep mode	–	35	–		–

**Note**

2. Guaranteed by characterization.

## 6.2.1 GPIO

**Table 6 GPIO DC specifications**

Spec ID#	Parameter	Description	Min	Typ	Max	Unit	Details/ conditions
SID57	$V_{IH}^{[3]}$	Input voltage high threshold	$0.7 \times V_{DDD}$	-	-	V	CMOS Input
SID58	$V_{IL}$	Input voltage low threshold	-	-	$0.3 \times V_{DDD}$		CMOS Input
SID241	$V_{IH}^{[3]}$	LVTTL input, $V_{DDD} < 2.7 V$	$0.7 \times V_{DDD}$	-	-		-
SID242	$V_{IL}$	LVTTL input, $V_{DDD} < 2.7 V$	-	-	$0.3 \times V_{DDD}$		-
SID243	$V_{IH}^{[3]}$	LVTTL input, $V_{DDD} \geq 2.7 V$	2.0	-	-		-
SID244	$V_{IL}$	LVTTL input, $V_{DDD} \geq 2.7 V$	-	-	0.8		-
SID59	$V_{OH}$	Output voltage high level	$V_{DDD} - 0.6$	-	-		$I_{OH} = 4 \text{ mA}$ at $3 V_{DDD}$
SID60	$V_{OH}$	Output voltage high level	$V_{DDD} - 0.5$	-	-		$I_{OH} = 1 \text{ mA}$ at $1.8 V_{DDD}$
SID61	$V_{OL}$	Output voltage low level	-	-	0.6		$I_{OL} = 4 \text{ mA}$ at $1.8 V_{DDD}$
SID62	$V_{OL}$	Output voltage low level	-	-	0.6		$I_{OL} = 10 \text{ mA}$ at $3 V_{DDD}$
SID62A	$V_{OL}$	Output voltage low level	-	-	0.4	$I_{OL} = 3 \text{ mA}$ at $3 V_{DDD}$	
SID63	$R_{PULLUP}$	Pull-up resistor	3.5	5.6	8.5	k $\Omega$	-
SID64	$R_{PULLDOWN}$	Pull-down resistor	3.5	5.6	8.5		-
SID65	$I_{IL}$	Input leakage current (absolute value)	-	2	-	nA	-
SID66	$C_{IN}$	Input capacitance	-	3	7	pF	-
SID67 <sup>[4]</sup>	$V_{HYSTTL}$	Input hysteresis LVTTL	15	40	-	mV	$V_{DDD} \geq 2.7 V$
SID68 <sup>[4]</sup>	$V_{HYSCMOS}$	Input hysteresis CMOS	$0.05 \times V_{DDD}$	-	-		$V_{DD} < 4.5 V$
SID68A <sup>[4]</sup>	$V_{HYSCMOS5V5}$	Input hysteresis CMOS	200	-	-		$V_{DD} > 4.5 V$
SID69 <sup>[4]</sup>	$I_{DIODE}$	Current through protection diode to $V_{DD}/V_{SS}$	-	-	100	$\mu A$	-
SID69A <sup>[4]</sup>	$I_{TOT\_GPIO}$	Maximum total source or sink chip current	-	-	85	mA	-

### Notes

- $V_{IH}$  must not exceed  $V_{DDD} + 0.2 V$ .
- Guaranteed by characterization.

Electrical specifications

**Table 7 GPIO AC specifications**

(Guaranteed by characterization)

Spec ID#	Parameter	Description	Min	Typ	Max	Unit	Details/conditions
SID70	T <sub>RISEF</sub>	Rise time in fast strong mode	2	–	12	ns	3.3 V V <sub>DDD</sub> , Clload = 25 pF
SID71	T <sub>FALLF</sub>	Fall time in fast strong mode	2	–	12		3.3 V V <sub>DDD</sub> , Clload = 25 pF
SID72	T <sub>RISES</sub>	Rise time in slow strong mode	10	–	60	ns	3.3 V V <sub>DDD</sub> , Clload = 25 pF
SID73	T <sub>FALLS</sub>	Fall time in slow strong mode	10	–	60	ns	3.3 V V <sub>DDD</sub> , Clload = 25 pF
SID74	F <sub>GPIOUT1</sub>	GPIO F <sub>OUT</sub> ; 3.3 V ≤ V <sub>DDD</sub> ≤ 5.5 V Fast strong mode	–	–	16	MHz	90/10%, 25-pF load, 60/40 duty cycle
SID75	F <sub>GPIOUT2</sub>	GPIO F <sub>OUT</sub> ; 1.71 V ≤ V <sub>DDD</sub> ≤ 3.3 V Fast strong mode	–	–	16		90/10%, 25-pF load, 60/40 duty cycle
SID76	F <sub>GPIOUT3</sub>	GPIO F <sub>OUT</sub> ; 3.3 V ≤ V <sub>DDD</sub> ≤ 5.5 V Slow strong mode	–	–	7		90/10%, 25-pF load, 60/40 duty cycle
SID245	F <sub>GPIOUT4</sub>	GPIO F <sub>OUT</sub> ; 1.71 V ≤ V <sub>DDD</sub> ≤ 3.3 V Slow strong mode.	–	–	3.5		90/10%, 25-pF load, 60/40 duty cycle
SID246	F <sub>GPIOIN</sub>	GPIO input operating frequency; 1.71 V ≤ V <sub>DDD</sub> ≤ 5.5 V	–	–	48		90/10% V <sub>IO</sub>

## 6.2.2 XRES

**Table 8 XRES DC specifications**

Spec ID#	Parameter	Description	Min	Typ	Max	Unit	Details/ conditions
SID77	$V_{IH}$	Input voltage high threshold	$0.7 \times V_{DDD}$	–	–	V	CMOS Input
SID78	$V_{IL}$	Input voltage low threshold	–	–	$0.3 \times V_{DDD}$		
SID79	$R_{PULLUP}$	Pull-up resistor	–	60	–	k $\Omega$	–
SID80	$C_{IN}$	Input capacitance	–	3	7	pF	–
SID81 <sup>[5]</sup>	$V_{HYSXRES}$	Input voltage hysteresis	–	$0.05 \times V_{DD}$	–	mV	Typical hysteresis is 200 mV for $V_{DD} > 4.5$ V

**Table 9 XRES AC specifications**

Spec ID#	Parameter	Description	Min	Typ	Max	Unit	Details/ conditions
SID83 <sup>[5]</sup>	$T_{RESETWIDTH}$	Reset pulse width	1	–	–	$\mu$ s	–
BID194 <sup>[5]</sup>	$T_{RESETWAKE}$	Wake-up time from reset release	–	–	2.5	ms	–

### Note

5. Guaranteed by characterization.

## 6.3 Analog peripherals

### 6.3.1 CTB Opamp

**Table 10 CTB Opamp specifications**

Spec ID#	Parameter	Description	Min	Typ	Max	Unit	Details/conditions
	$I_{DD}$	Opamp block current, No load					
SID269	$I_{DD\_HI}$	power = hi	–	1100	2070	μA	–
SID270	$I_{DD\_MED}$	power = med	–	550	950		–
SID271	$I_{DD\_LOW}$	power = lo	–	150	350		–
	$G_{BW}$	Load = 20 pF, 0.1 mA, $V_{DDA} = 2.7 V$					
SID272	$G_{BW\_HI}$	power = hi	6	–	–	MHz	Input and output are 0.2 V to $V_{DDA} - 0.2 V$
SID273	$G_{BW\_MED}$	power = med	3	–	–		Input and output are 0.2 V to $V_{DDA} - 0.2 V$
SID274	$G_{BW\_LO}$	power = lo	–	1	–		Input and output are 0.2 V to $V_{DDA} - 0.2 V$
	$I_{OUT\_MAX}$	$V_{DDA} = 2.7 V$ , 500 mV from rail					
SID275	$I_{OUT\_MAX\_HI}$	power = hi	10	–	–	mA	Output is 0.5 V to $V_{DDA} - 0.5 V$
SID276	$I_{OUT\_MAX\_MID}$	power = mid	10	–	–		Output is 0.5 V to $V_{DDA} - 0.5 V$
SID277	$I_{OUT\_MAX\_LO}$	power = lo	–	5	–		Output is 0.5 V to $V_{DDA} - 0.5 V$
	$I_{OUT}$	$V_{DDA} = 1.71 V$ , 500 mV from rail					
SID278	$I_{OUT\_MAX\_HI}$	power = hi	4	–	–	mA	Output is 0.5 V to $V_{DDA} - 0.5 V$
SID279	$I_{OUT\_MAX\_MID}$	power = mid	4	–	–		Output is 0.5 V to $V_{DDA} - 0.5 V$
SID280	$I_{OUT\_MAX\_LO}$	power = lo	–	2	–		Output is 0.5 V to $V_{DDA} - 0.5 V$
	$I_{DD\_Int}$	Opamp block current Internal Load					
SID269_I	$I_{DD\_HI\_Int}$	power = hi	–	1500	2300	μA	–
SID270_I	$I_{DD\_MED\_Int}$	power = med	–	700	1200		–
	$G_{BW}$	$V_{DDA} = 2.7 V$					
SID272_I	$G_{BW\_HI\_Int}$	power = hi	8	–	–	MHz	Output is 0.25 V to $V_{DDA} - 0.25 V$

Electrical specifications

**Table 10** CTB Opamp specifications (continued)

Spec ID#	Parameter	Description	Min	Typ	Max	Unit	Details/conditions
General opamp specs for both internal and external modes							
SID281	$V_{IN}$	Charge-pump on, $V_{DDA} = 2.7\text{ V}$	-0.05	-	$V_{DDA} - 0.2$	V	-
SID282	$V_{CM}$	Charge-pump on, $V_{DDA} = 2.7\text{ V}$	-0.05	-	$V_{DDA} - 0.2$		-
SID283	$V_{OUT\_1}$	power = hi, Iload = 10 mA	0.5	-	$V_{DDA} - 0.5$	V	$V_{DD} = 2.7\text{ V}$
SID284	$V_{OUT\_2}$	power = hi, Iload = 1 mA	0.2	-	$V_{DDA} - 0.2$		$V_{DDA} = 2.7\text{ V}$
SID285	$V_{OUT\_3}$	power = med, Iload = 1 mA	0.2	-	$V_{DDA} - 0.2$		$V_{DDA} = 2.7\text{ V}$
SID286	$V_{OUT\_4}$	power = lo, Iload = 0.1 mA	0.2	-	$V_{DDA} - 0.2$		$V_{DDA} = 2.7\text{ V}$
SID288	$V_{OS\_TR}$	Offset voltage, trimmed	-1.0	$\pm 0.5$	1.0	mV	High mode, input 0 V to $V_{DDA} - 0.2\text{ V}$
SID288A	$V_{OS\_TR}$	Offset voltage, trimmed	-	$\pm 1$	-		Medium mode, input 0 V to $V_{DDA} - 0.2\text{ V}$
SID288B	$V_{OS\_TR}$	Offset voltage, trimmed	-	$\pm 2$	-		Low mode, input 0 V to $V_{DDA} - 0.2\text{ V}$
SID290	$V_{OS\_DR\_TR}$	Offset voltage drift, trimmed	-10	$\pm 3$	10	$\mu\text{V}/\text{C}$	High mode
SID290A	$V_{OS\_DR\_TR}$	Offset voltage drift, trimmed	-	$\pm 10$	-	$\mu\text{V}/\text{C}$	Medium mode
SID290B	$V_{OS\_DR\_TR}$	Offset voltage drift, trimmed	-	$\pm 10$	-		Low mode
SID291	CMRR	DC	70	80	-	dB	Input is 0 V to $V_{DDA} - 0.2\text{ V}$ , Output is 0.2 V to $V_{DDA} - 0.2\text{ V}$ , $V_{DDA} \geq 2.7\text{ V}$
SID291A	CMRR2	DC	60	70	-		Input is 0 V to $V_{DDA} - 0.2\text{ V}$ , Output is 0.2 V to $V_{DDA} - 0.2\text{ V}$ . $1.71\text{ V} \leq V_{DDA} < 2.7\text{ V}$
SID292	PSRR	At 1 kHz, 10-mV ripple	70	85	-		$V_{DDD} = 3.6\text{ V}$ , high-power mode, input is 0.2 V to $V_{DDA} - 0.2\text{ V}$

Electrical specifications

**Table 10** CTB Opamp specifications (continued)

Spec ID#	Parameter	Description	Min	Typ	Max	Unit	Details/conditions
	Noise						
SID294	VN2	Input-referred, 1 kHz, power = Hi	–	72	–	nV/ rtHz	Input and output are at 0.2 V to $V_{DDA} - 0.2$ V
SID295	VN3	Input-referred, 10 kHz, power = Hi	–	28	–		Input and output are at 0.2 V to $V_{DDA} - 0.2$ V
SID296	VN4	Input-referred, 100 kHz, power = Hi	–	15	–		Input and output are at 0.2 V to $V_{DDA} - 0.2$ V
SID297	$C_{LOAD}$	Stable up to max. load. Performance specs at 50 pF.	–	–	125	pF	–
SID298	SLEW_RATE	$C_{LOAD} = 50$ pF, Power = High, $V_{DDA} = 2.7$ V	6	–	–	V/ $\mu$ s	–
SID299	T_OP_WAKE	From disable to enable, no external RC dominating	–	–	25	$\mu$ s	–
SID299A	OL_GAIN	Open Loop Gain	–	90	–	dB	–
	COMP_MODE	Comparator mode; 50-mV drive, $T_{rise} = T_{fall}$ (approx)					
SID300	$T_{PD1}$	Response time; power = hi	–	150	175	ns	Input is 0.2 V to $V_{DDA} - 0.2$ V
SID301	$T_{PD2}$	Response time; power = med	–	500	–		Input is 0.2 V to $V_{DDA} - 0.2$ V
SID302	$T_{PD3}$	Response time; power = lo	–	2500	–		Input is 0.2 V to $V_{DDA} - 0.2$ V
SID303	$V_{HYST\_OP}$	Hysteresis	–	10	–	mV	–
SID304	WUP_CTB	Wake-up time from Enabled to Usable	–	–	25	$\mu$ s	–

Electrical specifications

**Table 10** CTB Opamp specifications (continued)

Spec ID#	Parameter	Description	Min	Typ	Max	Unit	Details/conditions
	Opamp Deep Sleep Mode	Mode 2 is lowest current range. Mode 1 has higher GBW.					
SID_DS_1	I <sub>DD_HI_M1</sub>	Mode 1, High current	–	1400	–	μA	–
SID_DS_2	I <sub>DD_MED_M1</sub>	Mode 1, Medium current	–	700	–		–
SID_DS_3	I <sub>DD_LOW_M1</sub>	Mode 1, Low current	–	200	–		–
SID_DS_4	I <sub>DD_HI_M2</sub>	Mode 2, High current	–	120	–	μA	–
SID_DS_5	I <sub>DD_MED_M2</sub>	Mode 2, Medium current	–	60	–		–
SID_DS_6	I <sub>DD_LOW_M2</sub>	Mode 2, Low current	–	15	–		–
SID_DS_7	G <sub>BW_HI_M1</sub>	Mode 1, High current	–	4	–	MHz	20-pF load, no DC load 0.2 V to V <sub>DDA</sub> – 0.2 V
SID_DS_8	G <sub>BW_MED_M1</sub>	Mode 1, Medium current	–	2	–		20-pF load, no DC load 0.2 V to V <sub>DDA</sub> – 0.2 V
SID_DS_9	G <sub>BW_LOW_M1</sub>	Mode 1, Low current	–	0.5	–		20-pF load, no DC load 0.2 V to V <sub>DDA</sub> – 0.2 V
SID_DS_10	G <sub>BW_HI_M2</sub>	Mode 2, High current	–	0.5	–		20-pF load, no DC load 0.2 V to V <sub>DDA</sub> – 0.2 V
SID_DS_11	G <sub>BW_MED_M2</sub>	Mode 2, Medium current	–	0.2	–		20-pF load, no DC load 0.2 V to V <sub>DDA</sub> – 0.2 V
SID_DS_12	G <sub>BW_Low_M2</sub>	Mode 2, Low current	–	0.1	–		20-pF load, no DC load 0.2 V to V <sub>DDA</sub> – 0.2 V
SID_DS_13	V <sub>OS_HI_M1</sub>	Mode 1, High current	–	5	–	mV	With trim 25°C, 0.2 V to V <sub>DDA</sub> – 1.5 V
SID_DS_14	V <sub>OS_MED_M1</sub>	Mode 1, Medium current	–	5	–		With trim 25°C, 0.2 V to V <sub>DDA</sub> – 1.5 V
SID_DS_15	V <sub>OS_LOW_M1</sub>	Mode 1, Low current	–	5	–		With trim 25°C, 0.2 V to V <sub>DDA</sub> – 1.5 V
SID_DS_16	V <sub>OS_HI_M2</sub>	Mode 2, High current	–	5	–		With trim 25°C, 0.2 V to V <sub>DDA</sub> – 1.5 V
SID_DS_17	V <sub>OS_MED_M2</sub>	Mode 2, Medium current	–	5	–		With trim 25°C, 0.2 V to V <sub>DDA</sub> – 1.5 V
SID_DS_18	V <sub>OS_LOW_M2</sub>	Mode 2, Low current	–	5	–		With trim 25°C, 0.2 V to V <sub>DDA</sub> – 1.5 V

Electrical specifications

**Table 10** CTB Opamp specifications (continued)

Spec ID#	Parameter	Description	Min	Typ	Max	Unit	Details/conditions
SID_DS_19	I <sub>OUT_HI_M1</sub>	Mode 1, High current	–	10	–	mA	Output is 0.5 V to V <sub>DDA</sub> – 0.5 V
SID_DS_20	I <sub>OUT_MED_M1</sub>	Mode 1, Medium current	–	10	–		Output is 0.5 V to V <sub>DDA</sub> – 0.5 V
SID_DS_21	I <sub>OUT_LOW_M1</sub>	Mode 1, Low current	–	4	–		Output is 0.5 V to V <sub>DDA</sub> – 0.5 V
SID_DS_22	I <sub>OUT_HI_M2</sub>	Mode 2, High current	–	1	–		–
SID_DS_23	I <sub>OU_MED_M2</sub>	Mode 2, Medium current	–	1	–		–
SID_DS_24	I <sub>OU_LOW_M2</sub>	Mode 2, Low current	–	0.5	–		–

### 6.3.2 PGA

**Table 11** PGA specifications

Spec ID#	Parameter	Description	Min	Typ	Max	Unit	Details/ conditions
PGA Gain Values	-	Gain Values are 2, 4, 16, and 32.	2	-	32	-	-
SID_PGA_1	PGA_ERR_1	Gain Error for Low range; Gain = 2	-	1	-	%	-
		Gain Error for Medium range; Gain = 2	-	-	1.5	%	-
		Gain Error for High range; Gain = 2	-	-	1.5	%	-
SID_PGA_2	PGA_ERR_2	Gain Error for Low range; Gain = 4	-	1	-	%	-
		Gain Error for Medium range; Gain = 4	-	-	1.5	%	-
		Gain Error for High range; Gain = 4	-	-	1.5	%	-
SID_PGA_3	PGA_ERR_3	Gain Error for Low range; Gain = 16	-	3	-	%	-
		Gain Error for Medium range; Gain = 16	-	3	-	%	-
		Gain Error for High range; Gain = 16	-	3	-	%	-
SID_PGA_4	PGA_ERR_4	Gain Error for Low range; Gain = 32	-	5	-	%	-
		Gain Error for Medium range; Gain = 32	-	5	-	%	-
		Gain Error for High range; Gain = 32	-	5	-	%	-

### 6.3.3 Voltage DAC

**Table 12 Voltage DAC specifications**

(VDAC specs are valid from -20°C to 85°C)

Spec ID#	Parameter	Description	Min	Typ	Max	Unit	Details/conditions
13-bit DAC							
SID_DAC_1	INL_VDAC1	Integral non linearity (INL)	-6	-	5	LSB	-
SID_DAC_2	DNL_VDAC1	Differential non linearity (DNL)	-1	-	4		-
SID_DAC_3	VOUT_VDAC1	Output voltage range	0.2	-	$V_{DDA} - 0.2$	V	Valid output range is 200 LSBs from rails. Full settling bandwidth to within 200 mV of rail.
SID_DAC_4	ZSE_VDAC1	Zero scale error (output with all zeroes input)	-	20	-	mV	Zero scale is at analog ground.
SID_DAC_5	GE_VDAC1	Full scale error less offset	-	0.3	2	%	$V_{DDA} \geq 2.7 V$ , $V_{REF} = V_{DDA}/2$
SID_DAC_6	IDD_VDAC1	Block current	-	1.8	-	mA	-
SID_DAC_7	PSRR_VDAC1	Power supply rejection ratio	-	50	-	dB	$2.7 V < V_{DDA} \leq 5.5 V$
SID_DAC_8	WUP_VDAC1	Wake-up time from Enabled to Usable	-	-	32	$\mu s$	$2.7 V < V_{DDA} \leq 5.5 V$
SID_DAC_8A	WUP_VDAC2	Wake-up time from Enabled to Usable	-	-	72	$\mu s$	$V_{DDA} \leq 2.7 V$
SID_DAC_9	TS_VDAC1	Settling time for DAC	-	-	2	$\mu s$	500 ksps operation, $V_{DDA} \geq 2.7 V$
SID_DAC_9A	TS_VDAC2	Settling time for DAC	-	-	10	$\mu s$	100 ksps operation, $V_{DDA} \leq 2.7 V$

**Note**

6. Guaranteed by characterization.

### 6.3.4 Comparator

**Table 13** Comparator DC specifications

Spec ID#	Parameter	Description	Min	Typ	Max	Unit	Details/conditions
SID84	V <sub>OFFSET1</sub>	Input offset voltage, Factory trim	-	-	±10	mV	-
SID85	V <sub>OFFSET2</sub>	Input offset voltage, Custom trim	-	-	±4		-
SID86	V <sub>HYST</sub>	Hysteresis when enabled	-	10	35		-
SID87	V <sub>ICM1</sub>	Input common mode voltage in normal mode	0	-	V <sub>DDD</sub> - 0.1	V	Modes 1 and 2
SID247	V <sub>ICM2</sub>	Input common mode voltage in low power mode	0	-	V <sub>DDD</sub>		-
SID247A	V <sub>ICM3</sub>	Input common mode voltage in ultra low power mode	0	-	V <sub>DDD</sub> - 1.15		V <sub>DDD</sub> ≥ 2.2 V for Temp < 0°C, V <sub>DDD</sub> ≥ 1.8 V for Temp > 0°C
SID88	C <sub>MRR</sub>	Common mode rejection ratio	50	-	-	dB	V <sub>DDD</sub> ≥ 2.7 V
SID88A	C <sub>MRR</sub>	Common mode rejection ratio	42	-	-		V <sub>DDD</sub> ≤ 2.7 V
SID89	I <sub>CMP1</sub>	Block current, normal mode	-	-	400	μA	-
SID248	I <sub>CMP2</sub>	Block current, low power mode	-	-	100		-
SID259	I <sub>CMP3</sub>	Block current in ultra low-power mode	-	-	28		V <sub>DDD</sub> ≥ 2.2 V for Temp < 0°C, V <sub>DDD</sub> ≥ 1.8 V for Temp > 0°C
SID90	Z <sub>CMP</sub>	DC Input impedance of comparator	35	-	-	MΩ	-

**Table 14** Comparator AC specifications

Spec ID#	Parameter	Description	Min	Typ	Max	Unit	Details/conditions
SID91	TRESP1	Response time, normal mode, 50 mV overdrive	-	38	110	ns	All V <sub>DD</sub>
SID258	TRESP2	Response time, low power mode, 50 mV overdrive	-	70	200		-
SID92	TRESP3	Response time, ultra-low power mode, 200 mV overdrive	-	2.3	15	μs	V <sub>DDD</sub> ≥ 2.2 V for Temp < 0°C, V <sub>DDD</sub> ≥ 1.8 V for Temp > 0°C

### 6.3.5 Temperature Sensor

**Table 15** Temperature Sensor specifications

Spec ID#	Parameter	Description	Min	Typ	Max	Unit	Details/conditions
SID93	TSENSACC	Temperature sensor accuracy	-5	±1	5	°C	-40°C to +85°C

### 6.3.6 SAR

**Table 16 SAR specifications**

Spec ID#	Parameter	Description	Min	Typ	Max	Unit	Details/conditions
<b>SAR ADC DC specifications</b>							
SID94	A_RES	Resolution	-	-	12	bits	-
SID95	A_CHNLS_S	Number of channels - single ended	-	-	8		8 full speed.
SID96	A-CHNKS_D	Number of channels - differential	-	-	4		-
SID97	A-MONO	Monotonicity	-	-	-		Yes.
SID98	A_GAINERR	Gain error	-	-	±0.1	%	With external reference.
SID99	A_OFFSET	Input offset voltage	-	-	2	mV	Measured with 1-V reference.
SID100	A_ISAR	Current consumption	-	-	1	mA	-
SID101	A_VINS	Input voltage range - single ended	V <sub>SS</sub>	-	V <sub>DDA</sub>	V	-
SID102	A_VIND	Input voltage range - differential	V <sub>SS</sub>	-	V <sub>DDA</sub>	V	-
SID103	A_INRES	Input resistance	-	-	2.2	KΩ	-
SID104	A_INCAP	Input capacitance	-	-	10	pF	-
SID260	VREFSAR	Trimmed internal reference to SAR	-	-	TBD	V	-
<b>SAR ADC AC specifications</b>							
SID106	A_PSRR	Power supply rejection ratio	70	-	-	dB	-
SID107	A_CMRR	Common mode rejection ratio	66	-	-	dB	Measured at 1 V.
SID108	A_SAMP	Sample rate	-	-	1	MspS	-
SID109	A_SNR	Signal-to-noise and distortion ratio (SINAD)	65	-	-	dB	F <sub>IN</sub> = 10 kHz
SID110	A_BW	Input bandwidth without aliasing	-	-	A <sub>samp</sub> /2	kHz	-
SID111	A_INL	Integral non linearity. V <sub>DD</sub> = 1.71 V to 5.5 V, 1 MspS	-1.7	-	2	LSB	V <sub>REF</sub> = 1 to V <sub>DD</sub>
SID111A	A_INL	Integral non linearity. V <sub>DDD</sub> = 1.71 V to 3.6 V, 1 MspS	-1.5	-	1.7	LSB	V <sub>REF</sub> = 1.71 to V <sub>DD</sub>
SID111B	A_INL	Integral non linearity. V <sub>DD</sub> = 1.71 V to 5.5 V, 500 kspS	-1.5	-	1.7	LSB	V <sub>REF</sub> = 1 to V <sub>DD</sub>

**Table 16 SAR specifications** (continued)

Spec ID#	Parameter	Description	Min	Typ	Max	Unit	Details/conditions
SID112	A_DNL	Differential non linearity. $V_{DD} = 1.71\text{ V to }5.5\text{ V}$ , 1 Msps	-1	-	2.2	LSB	$V_{REF} = 1\text{ to }V_{DD}$
SID112A	A_DNL	Differential non linearity. $V_{DD} = 1.71\text{ V to }3.6\text{ V}$ , 1 Msps	-1	-	2	LSB	$V_{REF} = 1.71\text{ to }V_{DD}$
SID112B	A_DNL	Differential non linearity. $V_{DD} = 1.71\text{ V to }5.5\text{ V}$ , 500 ksps	-1	-	2.2	LSB	$V_{REF} = 1\text{ to }V_{DD}$
SID113	A_THD	Total harmonic distortion	-	-	-65	dB	$F_{IN} = 10\text{ kHz}$
SID261	FSARINTREF	SAR operating speed without external ref. bypass	-	-	100	ksps	12-bit resolution

### 6.3.7 CAPSENSE™ and IDAC

**Table 17 CAPSENSE™ and IDAC specifications<sup>[7]</sup>**

Spec ID#	Parameter	Description	Min	Typ	Max	Unit	Details/conditions
SYS.PER#3	VDD_RIPPLE	Max allowed ripple on power supply, DC to 10 MHz	–	–	±50	mV	V <sub>DD</sub> > 2 V (with ripple), 25°C T <sub>A</sub> , Sensitivity = 0.1 pF
SYS.PER#16	VDD_RIPPLE_1.8	Max allowed ripple on power supply, DC to 10 MHz	–	–	±25	mV	V <sub>DD</sub> > 1.75 V (with ripple), 25°C T <sub>A</sub> , Parasitic Capacitance (CP) < 20 pF, Sensitivity ≥ 0.4 pF
SID.CSD.BLK	ICSD	Maximum block current	–	–	4000	μA	–
SID.CSD#15	VREF	Voltage reference for CSD and Comparator	0.6	1.2	V <sub>DDA</sub> – 0.6	V	V <sub>DDA</sub> – 0.6 V or 4.4 V, whichever is lower
SID.CSD#15A	VREF_EXT	External Voltage reference for CSD and Comparator	0.6	–	V <sub>DDA</sub> – 0.6	V	V <sub>DDA</sub> – 0.6 V or 4.4 V, whichever is lower
SID.CSD#16	IDAC1IDD	IDAC1 (7 bits) block current	–	–	1750	μA	–
SID.CSD#17	IDAC2IDD	IDAC2 (7 bits) block current	–	–	1750	μA	–
SID308	VCSD	Voltage range of operation	1.71	–	5.5	V	1.8 V ± 5% or 1.8 V to 5.5 V
SID308A	VCOMPIDAC	Voltage compliance range of IDAC	0.6	–	V <sub>DDA</sub> – 0.6	V	V <sub>DDA</sub> – 0.6 V or 4.4 V, whichever is lower
SID309	IDAC1DNL	DNL	–1	–	1	LSB	–
SID310	IDAC1INL	INL	–3	–	3	LSB	–
SID311	IDAC2DNL	DNL	–1	–	1.0	LSB	–
SID312	IDAC2INL	INL	–3	–	3	LSB	–
SID313	SNR	Ratio of counts of finger to noise. Guaranteed by characterization	5.0	–	–	Ratio	Capacitance range of 5 pF to 200 pF, 0.1 pF sensitivity. All use cases. V <sub>DDA</sub> > 2 V.
SID314	IDAC7_SRC1	Maximum Source current of 7-bit IDAC in low range	4.2	–	5.4	μA	LSB = 37.5 nA typ.
SID314A	IDAC7_SRC2	Maximum Source current of 7-bit IDAC in medium range	34	–	41	μA	LSB = 300 nA typ.

**Note**

7. For optimal CAPSENSE™ performance, Ports 0, 4, and 5 must be used for large DC loads.

Electrical specifications

**Table 17 CAPSENSE™ and IDAC specifications<sup>[7]</sup> (continued)**

Spec ID#	Parameter	Description	Min	Typ	Max	Unit	Details/conditions
SID314B	IDAC7_SRC3	Maximum Source current of 7-bit IDAC in high range	275	–	330	μA	LSB = 2.4 μA typ.
SID314C	IDAC7_SRC4	Maximum Source current of 7-bit IDAC in low range, 2X mode	8	–	10.5	μA	LSB = 37.5 nA typ. 2X output stage
SID314D	IDAC7_SRC5	Maximum Source current of 7-bit IDAC in medium range, 2X mode	69	–	82	μA	LSB = 300 nA typ. 2X output stage
SID314E	IDAC7_SRC6	Maximum Source current of 7-bit IDAC in high range, 2X mode	540	–	660	μA	LSB = 2.4 μA typ. 2X output stage
SID315	IDAC7_SINK_1	Maximum Sink current of 7-bit IDAC in low range	4.2	–	5.7	μA	LSB = 37.5 nA typ.
SID315A	IDAC7_SINK_2	Maximum Sink current of 7-bit IDAC in medium range	34	–	44	μA	LSB = 300 nA typ.
SID315B	IDAC7_SINK_3	Maximum Sink current of 7-bit IDAC in high range	260	–	340	μA	LSB = 2.4 μA typ.
SID315C	IDAC7_SINK_4	Maximum Sink current of 7-bit IDAC in low range, 2X mode	8	–	11.5	μA	LSB = 37.5 nA typ. 2X output stage
SID315D	IDAC7_SINK_5	Maximum Sink current of 7-bit IDAC in medium range, 2X mode	68	–	86	μA	LSB = 300 nA typ. 2X output stage
SID315E	IDAC7_SINK_6	Maximum Sink current of 7-bit IDAC in high range, 2X mode	540	–	700	μA	LSB = 2.4 μA typ. 2X output stage
SID315F	IDAC8_SRC_1	Maximum Source current of 8-bit IDAC in low range	8.4	–	10.8	μA	LSB = 37.5 nA typ.
SID315G	IDAC8_SRC_2	Maximum Source current of 8-bit IDAC in medium range	68	–	82	μA	LSB = 300 nA typ.

**Note**

7. For optimal CAPSENSE™ performance, Ports 0, 4, and 5 must be used for large DC loads.

Electrical specifications

**Table 17 CAPSENSE™ and IDAC specifications<sup>[7]</sup> (continued)**

Spec ID#	Parameter	Description	Min	Typ	Max	Unit	Details/conditions
SID315H	IDAC8_SRC_3	Maximum Source current of 8-bit IDAC in high range	550	–	680	μA	LSB = 2.4 μA typ.
SID315J	IDAC8_SINK_1	Maximum Sink current of 8-bit IDAC in low range	8.4	–	11.4	μA	LSB = 37.5 nA typ.
SID315K	IDAC8_SINK_2	Maximum Sink current of 8-bit IDAC in medium range	68	–	88	μA	LSB = 300 nA typ.
SID315L	IDAC8_SINK_3	Maximum Sink current of 8-bit IDAC in high range	540	–	670	μA	LSB = 2.4 μA typ.
SID320	IDACOFFSET1	All zeroes input; Medium and High range	–	–	1	LSB	Polarity set by Source or Sink
SID320A	IDACOFFSET2	All zeroes input; Low range	–	–	2	LSB	Polarity set by Source or Sink
SID321	IDACGAIN	Full-scale error less offset	–	–	±20	%	
SID322	IDACMISMATCH1	Mismatch between IDAC1 and IDAC2 in Low mode	–	–	9.2	LSB	LSB = 37.5 nA typ.
SID322A	IDACMISMATCH2	Mismatch between IDAC1 and IDAC2 in Medium mode	–	–	6	LSB	LSB = 300 nA typ.
SID322B	IDACMISMATCH3	Mismatch between IDAC1 and IDAC2 in High mode	–	–	6.8	LSB	LSB = 2.4 μA typ.
SID323	IDACSET8	Settling time to 0.5 LSB for 8-bit IDAC	–	–	10	μs	Full-scale transition. No external load.
SID324	IDACSET7	Settling time to 0.5 LSB for 7-bit IDAC	–	–	10	μs	Full-scale transition. No external load.
SID325	CMOD	External modulator capacitor.	–	2.2	–	nF	5-V rating, X7R or NP0 cap.

**Note**

7. For optimal CAPSENSE™ performance, Ports 0, 4, and 5 must be used for large DC loads.

**Table 18 10-bit CAPSENSE™ ADC specifications**

Spec ID#	Parameter	Description	Min	Typ	Max	Unit	Details/conditions
SIDA94	A_RES	Resolution	–	–	10	bits	8 full speed.
SID95	A_CHNLS_S	Number of channels - single-ended	–	–	16		Diff inputs use neighboring I/O
SIDA97	A-MONO	Monotonicity	–	–	–	Yes	Yes
SIDA98	A_GAINERR	Gain error	–	–	TBD	%	With external reference.
SIDA99	A_OFFSET	Input offset voltage	–	–	TBD	mV	Measured with 1-V reference.
SIDA100	A_ISAR	Current consumption	–	–	TBD	mA	–
SIDA101	A_VINS	Input voltage range - single-ended	V <sub>SSA</sub>	–	V <sub>DDA</sub>	V	–
SIDA103	A_INRES	Input resistance	–	2.2	–	KΩ	–
SIDA104	A_INCAP	Input capacitance	–	20	–	pF	–
SIDA106	A_PSRR	Power supply rejection ratio	TBD	–	–	dB	–
SIDA107	A_TACQ	Sample acquisition time	–	1	–	μs	–
SIDA108	A_CONV8	Conversion time for 8-bit resolution at conversion rate = $F_{clk}/(2^{(N+2)})$ . Clock frequency = 48 MHz.	–	–	21.3	μs	Does not include acquisition time. Equivalent to 44.8 ksps including acquisition time.
SIDA108A	A_CONV10	Conversion time for 10-bit resolution at conversion rate = $F_{clk}/(2^{(N+2)})$ . Clock frequency = 48 MHz.	–	–	85.3	μs	Does not include acquisition time. Equivalent to 11.6 ksps including acquisition time.
SIDA109	A_SND	Signal-to-noise and distortion ratio (SINAD)	TBD	–	–	dB	–
SIDA110	A_BW	Input bandwidth without aliasing	–	–	22.4	kHz	8-bit resolution
SIDA111	A_INL	Integral non linearity. V <sub>DD</sub> = 1.71 V to 5.5 V, 1 ksps	–	–	2	LSB	V <sub>REF</sub> = 2.4 V or greater
SIDA112	A_DNL	Differential non linearity. V <sub>DD</sub> = 1.71 V to 5.5 V, 1 ksps	–	–	1	LSB	–

## 6.4 Digital Peripherals

### 6.4.1 Timer Counter Pulse-Width Modulator (TCPWM)

**Table 19 TCPWM specifications**

Spec ID#	Parameter	Description	Min	Typ	Max	Unit	Details/conditions
SID.TCPWM.1	ITCPWM1	Block current consumption at 3 MHz	–	–	45	μA	All modes (TCPWM)
SID.TCPWM.2	ITCPWM2	Block current consumption at 12 MHz	–	–	155		All modes (TCPWM)
SID.TCPWM.2A	ITCPWM3	Block current consumption at 48 MHz	–	–	650		All modes (TCPWM)
SID.TCPWM.3	TCPWM <sub>FREQ</sub>	Operating frequency	–	–	Fc	MHz	Fc max = CLK_SYS Maximum = 48 MHz
SID.TCPWM.4	TPWM <sub>ENEXT</sub>	Input trigger pulse width	2/Fc	–	–	ns	For all trigger events <sup>[8]</sup>
SID.TCPWM.5	TPWM <sub>EXT</sub>	Output trigger pulse widths	2/Fc	–	–		Minimum possible width of Overflow, Underflow, and CC (Counter equals Compare value) outputs
SID.TCPWM.5A	TC <sub>RES</sub>	Resolution of counter	1/Fc	–	–		Minimum time between successive counts
SID.TCPWM.5B	PWM <sub>RES</sub>	PWM resolution	1/Fc	–	–		Minimum pulse width of PWM Output
SID.TCPWM.5C	Q <sub>RES</sub>	Quadrature inputs resolution	1/Fc	–	–		Minimum pulse width between Quadrature phase inputs

**Note**

8. Trigger events can be Stop, Start, Reload, Count, Capture, or Kill depending on which mode of operation is selected.

## 6.4.2 I<sup>2</sup>C

**Table 20** Fixed I<sup>2</sup>C DC specifications<sup>[9]</sup>

Spec ID	Parameter	Description	Min	Typ	Max	Unit	Details/conditions
SID149	I <sub>I2C1</sub>	Block current consumption at 100 kHz	–	–	50	μA	–
SID150	I <sub>I2C2</sub>	Block current consumption at 400 kHz	–	–	135		–
SID151	I <sub>I2C3</sub>	Block current consumption at 1 Mbps	–	–	310		–
SID152	I <sub>I2C4</sub>	I <sup>2</sup> C enabled in Deep Sleep mode	–	–	1.4		–

**Table 21** Fixed I<sup>2</sup>C AC specifications<sup>[9]</sup>

Spec ID#	Parameter	Description	Min	Typ	Max	Unit	Details/conditions
SID153	F <sub>I2C1</sub>	Bit rate	–	–	1	Mbps	–

**Note**

9. Guaranteed by characterization.

### 6.4.3 SPI

**Table 22 SPI DC specifications**<sup>[10]</sup>

Spec ID#	Parameter	Description	Min	Typ	Max	Unit	Details/conditions
SID163	ISPI1	Block current consumption at 1 Mbits/sec	–	–	360	μA	–
SID164	ISPI2	Block current consumption at 4 Mbits/sec	–	–	560		–
SID165	ISPI3	Block current consumption at 8 Mbits/sec	–	–	600		–

**Table 23 SPI AC specifications**<sup>[10]</sup>

Spec ID#	Parameter	Description	Min	Typ	Max	Unit	Details/conditions
SID166	FSPI	SPI Operating frequency (Master; 6X Oversampling)	–	–	8	MHz	SID166

**Fixed SPI Master Mode AC specifications**

SID167	TDMO	MOSI Valid after SClock driving edge	–	–	15	ns	–
SID168	TDSI	MISO Valid before SClock capturing edge	20	–	–		Full clock, late MISO sampling
SID169	THMO	Previous MOSI data hold time	0	–	–		Referred to Slave capturing edge

**Fixed SPI Slave Mode AC specifications**

SID170	TDMI	MOSI Valid before Sclock Capturing edge	40	–	–	ns	–
SID171	TDSO	MISO Valid after Sclock driving edge	–	–	$42 + 3 \times T_{scb}$		$T_{scb} = SCB \text{ clock}$
SID171A	TDSO_EXT	MISO Valid after Sclock driving edge in Ext. Clk mode	–	–	48		–
SID172	THSO	Previous MISO data hold time	0	–	–		–

**Note**

10. Guaranteed by characterization.

Electrical specifications

### 6.4.4 UART

**Table 24** UART DC specifications<sup>[11]</sup>

Spec ID#	Parameter	Description	Min	Typ	Max	Unit	Details/conditions
SID160	I <sub>UART1</sub>	Block current consumption at 100 Kbits/sec	–	–	55	μA	–
SID161	I <sub>UART2</sub>	Block current consumption at 1000 Kbits/sec	–	–	312	μA	–

**Table 25** UART AC specifications<sup>[11]</sup>

Spec ID#	Parameter	Description	Min	Typ	Max	Unit	Details/conditions
SID162	F <sub>UART</sub>	Bit rate	–	–	1	Mbps	–

### 6.4.5 LCD

**Table 26** LCD Direct Drive DC specifications<sup>[11]</sup>

Spec ID#	Parameter	Description	Min	Typ	Max	Unit	Details/conditions
SID154	I <sub>LCDLOW</sub>	Operating current in low power mode	–	5	–	μA	16 × 4 small segment disp. at Hz
SID155	C <sub>LCDCAP</sub>	LCD capacitance per segment/common driver	–	500	5000	pF	–
SID156	LCD <sub>OFFSET</sub>	Long-term segment offset	–	20	–	mV	–
SID157	I <sub>LCDOP1</sub>	LCD system operating current V <sub>bias</sub> = 5 V	–	2	–	mA	32 × 4 segments. 50 Hz. 25°C
SID158	I <sub>LCDOP2</sub>	LCD system operating current V <sub>bias</sub> = 3.3 V	–	2	–		32 × 4 segments. 50 Hz. 25°C 4 segments. 50 Hz. 25°C.

**Table 27** LCD Direct Drive AC specifications<sup>[11]</sup>

Spec ID#	Parameter	Description	Min	Typ	Max	Unit	Details/conditions
SID159	F <sub>LCD</sub>	LCD frame rate	10	50	150	Hz	–

**Note**

11. Guaranteed by characterization.

## 6.5 Memory

### 6.5.1 Flash

**Table 28 Flash DC specifications**

Spec ID#	Parameter	Description	Min	Typ	Max	Unit	Details/conditions
SID173	V <sub>PE</sub>	Erase and program voltage	1.71	–	5.5	V	–

**Table 29 Flash AC specifications**

Spec ID#	Parameter	Description	Min	Typ	Max	Unit	Details/conditions
SID174	T <sub>ROWWRITE</sub> <sup>[12]</sup>	Row (block) write time (erase and program)	–	–	20	ms	Row (block) = 64 bytes
SID175	T <sub>ROWERASE</sub> <sup>[12]</sup>	Row erase time	–	–	13		–
SID176	T <sub>ROWPROGRAM</sub> <sup>[12]</sup>	Row program time after erase	–	–	7		–
SID178	T <sub>BULKERASE</sub> <sup>[12]</sup>	Bulk erase time (16 KB)	–	–	15		–
SID180 <sup>[13]</sup>	T <sub>DEVPROG</sub> <sup>[12]</sup>	Total device program time	–	–	7.5	Seconds	–
SID181 <sup>[13]</sup>	F <sub>END</sub>	Flash endurance	100K	–	–	Cycles	–
SID182 <sup>[13]</sup>	F <sub>RET</sub>	Flash retention. T <sub>A</sub> ≤ 55°C, 100 K P/E cycles	20	–	–	Years	–
SID182A <sup>[13]</sup>	–	Flash retention. T <sub>A</sub> ≤ 85°C, 10 K P/E cycles	10	–	–		–
SID182B <sup>[13]</sup>	F <sub>RETQ</sub>	Flash retention. T <sub>A</sub> ≤ 105°C, 10 K P/E cycles; ≤ three years at T <sub>A</sub> ≥ 85°C	10	–	–		Guaranteed by characterization
SID256	TWS48	Number of Wait states at 48 MHz	2	–	–		CPU execution from Flash
SID257	TWS24	Number of Wait states at 24 MHz	1	–	–		CPU execution from Flash

#### Notes

12. It can take as much as 20 milliseconds to write to Flash. During this time the device should not be Reset, or Flash operations will be interrupted and cannot be relied on to have completed. Reset sources include the XRES pin, software resets, CPU lockup states and privilege violations, improper power supply levels, and watchdogs. Make certain that these are not inadvertently activated.

13. Guaranteed by characterization.

## 6.6 System resources

### 6.6.1 Power-on Reset (POR)

**Table 30** POR

Spec ID#	Parameter	Description	Min	Typ	Max	Unit	Details/conditions
SID.CLK#6	SR_POWER_UP	Power supply slew rate	1	–	67	V/ms	At power-up and power-down.
SID185 <sup>[14]</sup>	V <sub>RISEIPOR</sub>	Rising trip voltage	0.80	–	1.5	V	–
SID186 <sup>[14]</sup>	V <sub>FALLIPOR</sub>	Falling trip voltage	0.70	–	1.4		–

**Table 31** Brown-out Detect (BOD) for V<sub>CCD</sub>

Spec ID	Parameter	Description	Min	Typ	Max	Unit	Details/conditions
SID190 <sup>[14]</sup>	V <sub>FALLPPOR</sub>	BOD trip voltage in active and sleep modes	1.48	–	1.62	V	–
SID192 <sup>[14]</sup>	V <sub>FALLDPSLP</sub>	BOD trip voltage in Deep Sleep	1.1	–	1.5		–

### 6.6.2 SWD Interface

**Table 32** SWD Interface specifications

Spec ID#	Parameter	Description	Min	Typ	Max	Unit	Details/conditions
SID213	F_SWDCCLK1	$3.3\text{ V} \leq V_{DD} \leq 5.5\text{ V}$	–	–	14	MHz	SWDCCLK ≤ 1/3 CPU clock frequency
SID214	F_SWDCCLK2	$1.71\text{ V} \leq V_{DD} \leq 3.3\text{ V}$	–	–	7		SWDCCLK ≤ 1/3 CPU clock frequency
SID215 <sup>[14]</sup>	T_SWDI_SETUP	$T = 1/f\text{ SWDCCLK}$	$0.25 \times T$	–	–	ns	–
SID216 <sup>[14]</sup>	T_SWDI_HOLD	$T = 1/f\text{ SWDCCLK}$	$0.25 \times T$	–	–		–
SID217 <sup>[14]</sup>	T_SWDO_VALID	$T = 1/f\text{ SWDCCLK}$	–	–	$0.5 \times T$		–
SID217A <sup>[14]</sup>	T_SWDO_HOLD	$T = 1/f\text{ SWDCCLK}$	1	–	–		–

**Note**

14. Guaranteed by characterization.

### 6.6.3 Internal Main Oscillator (IMO)

**Table 33 IMO DC specifications**

(Guaranteed by design)

Spec ID#	Parameter	Description	Min	Typ	Max	Unit	Details/conditions
SID218	I <sub>IMO1</sub>	IMO operating current at 48 MHz	–	–	250	μA	–
SID219	I <sub>IMO2</sub>	IMO operating current at 24 MHz	–	–	180	μA	–

**Table 34 IMO AC specifications**

Spec ID	Parameter	Description	Min	Typ	Max	Unit	Details/conditions
SID223	F <sub>IMOTOL1</sub>	Frequency range from 24 MHz to 48 MHz (4-MHz increments)	–2	–	+2	%	2 V ≤ V <sub>DD</sub> ≤ 5.5 V, and –25°C ≤ T <sub>A</sub> ≤ 85°C
SID226	T <sub>STARTIMO</sub>	IMO startup time	–	–	7	μs	–
SID228	T <sub>JITRMSIMO2</sub>	RMS jitter at 24 MHz	–	145	–	ps	–

### 6.6.4 Internal low-speed oscillator (ILO)

**Table 35 ILO DC specifications**

(Guaranteed by design)

Spec ID	Parameter	Description	Min	Typ	Max	Unit	Details/conditions
SID231 <sup>[15]</sup>	I <sub>ILO1</sub>	ILO operating current	–	0.3	1.05	μA	–

**Table 36 ILO AC specifications**

Spec ID	Parameter	Description	Min	Typ	Max	Unit	Details/conditions
SID234 <sup>[15]</sup>	T <sub>STARTILO1</sub>	ILO startup time	–	–	2	ms	–
SID236 <sup>[15]</sup>	T <sub>ILODUTY</sub>	ILO duty cycle	40	50	60	%	–
SID237	F <sub>ILOTRIM1</sub>	ILO frequency range	20	40	80	kHz	–

**Note**

15.Guaranteed by characterization.

## 6.6.5 Watch Crystal Oscillator (WCO)

**Table 37 Watch Crystal Oscillator (WCO) specifications**

Spec ID	Parameter	Description	Min	Typ	Max	Unit	Details/conditions
SID398	FWCO	Crystal Frequency	–	32.768	–	kHz	–
SID399	FTOL	Frequency tolerance	–	50	250	ppm	With 20-ppm crystal
SID400	ESR	Equivalent series resistance	–	50	–	kΩ	–
SID401	PD	Drive Level	–	–	1	μW	–
SID402	TSTART	Startup time	–	–	500	ms	–
SID403	CL	Crystal Load Capacitance	6	–	12.5	pF	–
SID404	C0	Crystal Shunt Capacitance	–	1.35	–	pF	–
SID405	IWCO1	Operating Current (high power mode)	–	–	8	μA	–

## 6.6.6 External Clock

**Table 38 External Clock specifications**

Spec ID	Parameter	Description	Min	Typ	Max	Unit	Details/conditions
SID305 <sup>[15]</sup>	ExtClkFreq	External clock input frequency	0	–	48	MHz	–
SID306 <sup>[15]</sup>	ExtClkDuty	Duty cycle; measured at $V_{DD/2}$	45	–	55	%	–

## 6.6.7 Block

**Table 39 Block specifications**

Spec ID	Parameter	Description	Min	Typ	Max	Unit	Details/conditions
SID262 <sup>[16]</sup>	$T_{CLKSWITCH}$	System clock source switching time	3	–	4	Periods	–

## 6.6.8 PRGIO Pass-through Time

**Table 40 PRGIO Pass-through Time (Delay in Bypass Mode)**

Spec ID	Parameter	Description	Min	Typ	Max	Unit	Details/conditions
SID252	PRG_BYPASS	Max. delay added by PRGIO in bypass mode	–	–	1.6	ns	–

### Note

16. Guaranteed by characterization.

## 7 Ordering information

**Table 41** Ordering information

Category	MPN	Features														Package				Temperature range (°C)			
		Max CPU Speed (MHz)	DMA	Flash (KB)	SRAM (KB)	13-bit VDAC	Opamp (CTB)	CAPSENSE™	10-bit CSD ADC	Direct LCD drive	RTC	12-bit SAR ADC	LP comparators	TCPWM blocks	SCB blocks	Smart IOs	GPIO	28-pin SSOP	45-ball WLCSOP		48-pin TQFP	48-pin QFN	
4125	CY8C4125PVI-PS421	24	✓	32	4	2	4	-	✓	✓	✓	806 ksp/s	2	8	2	8	20	✓	-	-	-	-40 to 85	
	CY8C4125FNI-PS423	24	✓	32	4	2	4	-	✓	✓	✓	806 ksp/s	2	8	2	8	37	-	✓	-	-		
	CY8C4125AZI-PS423	24	✓	32	4	2	4	-	✓	✓	✓	806 ksp/s	2	8	2	8	38	-	-	✓	-		
	CY8C4125LQI-PS423	24	✓	32	4	2	4	-	✓	✓	✓	806 ksp/s	2	8	2	8	38	-	-	-	✓		
4145	CY8C4145PVI-PS421	48	✓	32	4	2	4	-	✓	✓	✓	1000 ksp/s	2	8	2	8	20	✓	-	-	-	-40 to 105	
	CY8C4145FNI-PS423	48	✓	32	4	2	4	-	✓	✓	✓	1000 ksp/s	2	8	2	8	37	-	✓	-	-		
	CY8C4145FNQ-PS423	48	✓	32	4	2	4	-	✓	✓	✓	1000 ksp/s	2	8	2	8	37	-	✓	-	-		
	4145	CY8C4145AZI-PS423	48	✓	32	4	2	4	-	✓	✓	✓	1000 ksp/s	2	8	2	8	38	-	-	✓	-	-40 to 85
		CY8C4145LQI-PS423	48	✓	32	4	2	4	-	✓	✓	✓	1000 ksp/s	2	8	2	8	38	-	-	-	✓	
		CY8C4145PVI-PS431	48	✓	32	4	2	4	✓	✓	✓	✓	1000 ksp/s	2	8	3	8	20	✓	-	-	-	
		CY8C4145FNI-PS433	48	✓	32	4	2	4	✓	✓	✓	✓	1000 ksp/s	2	8	3	8	37	-	✓	-	-	
		CY8C4145FNQ-PS433	48	✓	32	4	2	4	✓	✓	✓	✓	1000 ksp/s	2	8	3	8	37	-	✓	-	-	
		CY8C4145AZI-PS433	48	✓	32	4	2	4	✓	✓	✓	✓	1000 ksp/s	2	8	3	8	38	-	-	✓	-	
CY8C4145LQI-PS433	48	✓	32	4	2	4	✓	✓	✓	✓	1000 ksp/s	2	8	3	8	38	-	-	-	✓			

Ordering information

The nomenclature used in the preceding table is based on the following part numbering convention:

**Table 42 Nomenclature**

Field	Description	Values	Meaning
CY8C	Cypress, an Infineon company prefix		
4	Architecture	4	Arm® Cortex®-M0+ CPU
A	Family	1	4100PS Family
B	Maximum frequency	2	24 MHz
		4	48 MHz
C	Flash Memory Capacity	5	32 KB
DE	Package Code	AZ	TQFP (0.5 mm pitch)
		LQ	QFN
		PV	SSOP
		FN	CSP
S	Series Designator	PS	S-Series
F	Temperature Range	I	Industrial
		Q	Extended Industrial
XYZ	Attributes Code	000–999	Code of feature set in the specific family

The following is an example of a part number:

**Example**

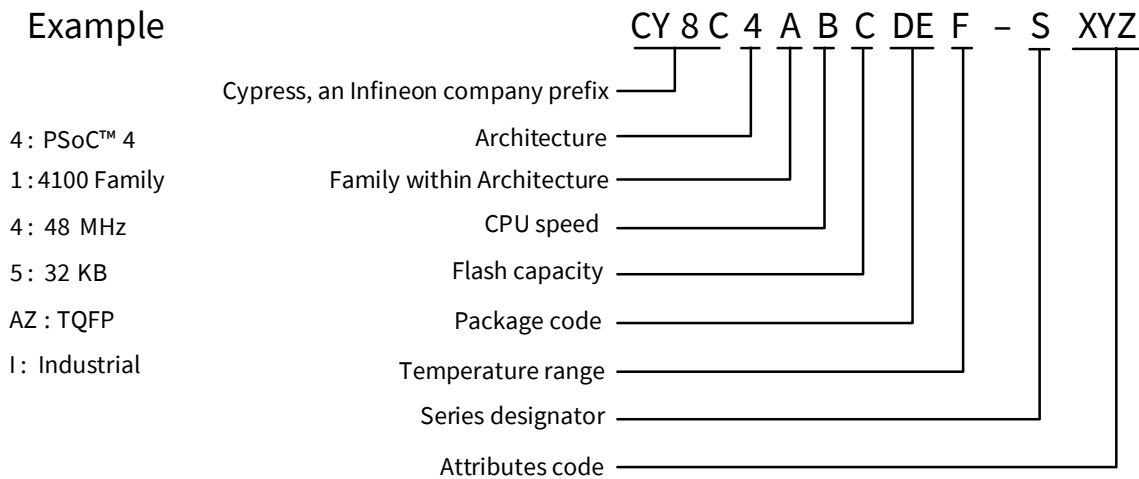

## 8 Packaging

**Table 43 Details**

Spec ID#	Package	Description	Package DWG #
BID20	48-pin TQFP	7 × 7 × 1.4 mm A48	51-85135
BID27	48-pin QFN	6 × 6 × 0.6 mm LR48A/LQ48A 4.6 × 4.6 E-Pad (Sawn)	001-57280
BID34	45-ball WLCSP	1.986 × 3.691 × 0.482 mm FN45B	002-24003
BID34A	28-pin SSOP	10.2 × 5.3 × 2.0 mm SP28	51-85079

**Table 44 Package Thermal characteristics**

Parameter	Description	Package	Min	Typ	Max	Unit
T <sub>A</sub>	Operating Ambient temperature	–	–40	25	105	°C
T <sub>J</sub>	Operating junction temperature	–	–40	–	125	°C
T <sub>JA</sub>	Package θ <sub>JA</sub>	48-pin TQFP	–	71	–	°C/W
T <sub>JC</sub>	Package θ <sub>JC</sub>	48-pin TQFP	–	34.3	–	°C/W
T <sub>JA</sub>	Package θ <sub>JA</sub>	48-pin QFN	–	18	–	°C/W
T <sub>JC</sub>	Package θ <sub>JC</sub>	48-pin QFN	–	4.5	–	°C/W
T <sub>JA</sub>	Package θ <sub>JA</sub>	45-ball WLCSP	–	37.2	–	°C/W
T <sub>JC</sub>	Package θ <sub>JC</sub>	45-ball WLCSP	–	0.31	–	°C/W
T <sub>JA</sub>	Package θ <sub>JA</sub>	28-pin SSOP	–	60	–	°C/W
T <sub>JC</sub>	Package θ <sub>JC</sub>	28-pin SSOP	–	25	–	°C/W

**Table 45 Solder Reflow Peak Temperature**

Package	Maximum Peak Temperature	Maximum Time at Peak Temperature
All	260°C	30 seconds

**Table 46 Package Moisture Sensitivity Level (MSL), IPC/JEDEC J-STD-020**

Package	MSL
All	MSL 3

## 8.1 Package diagrams

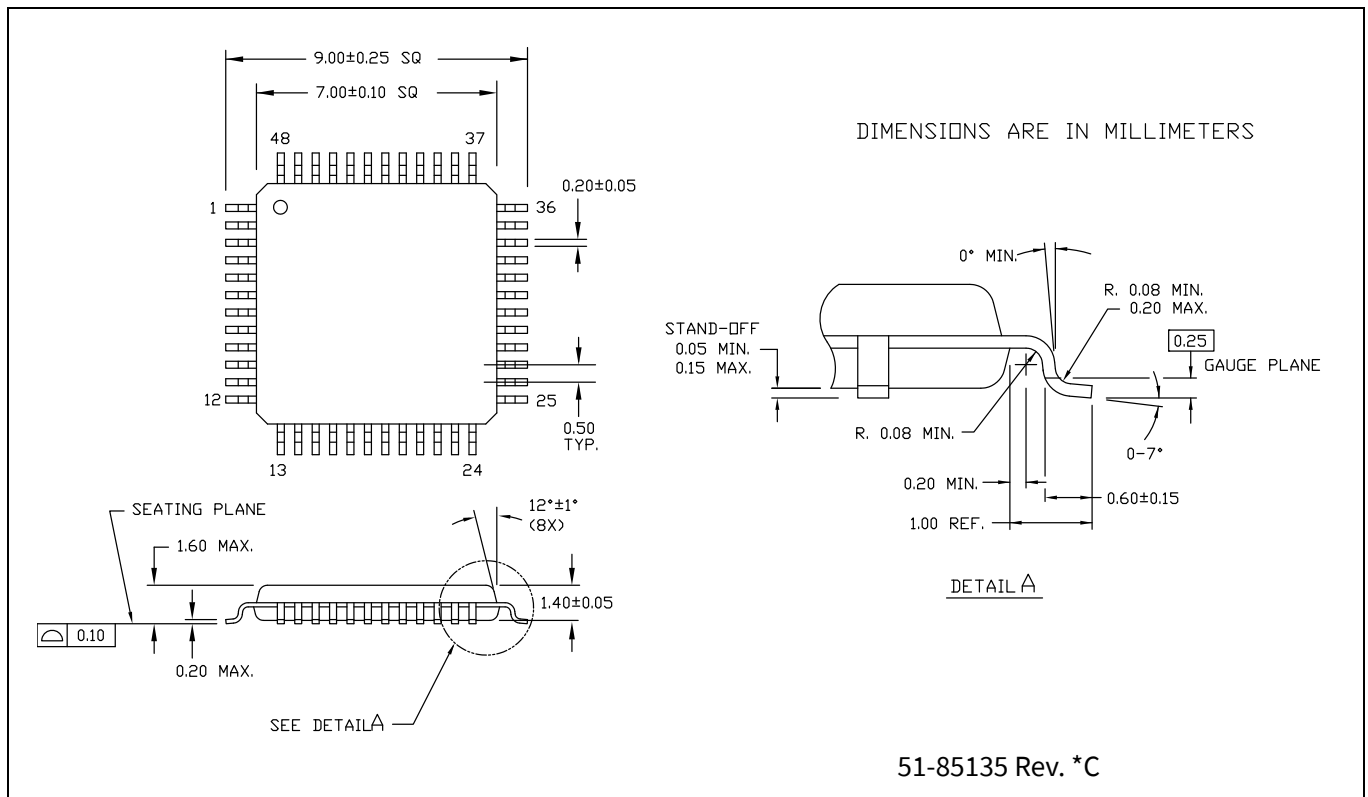
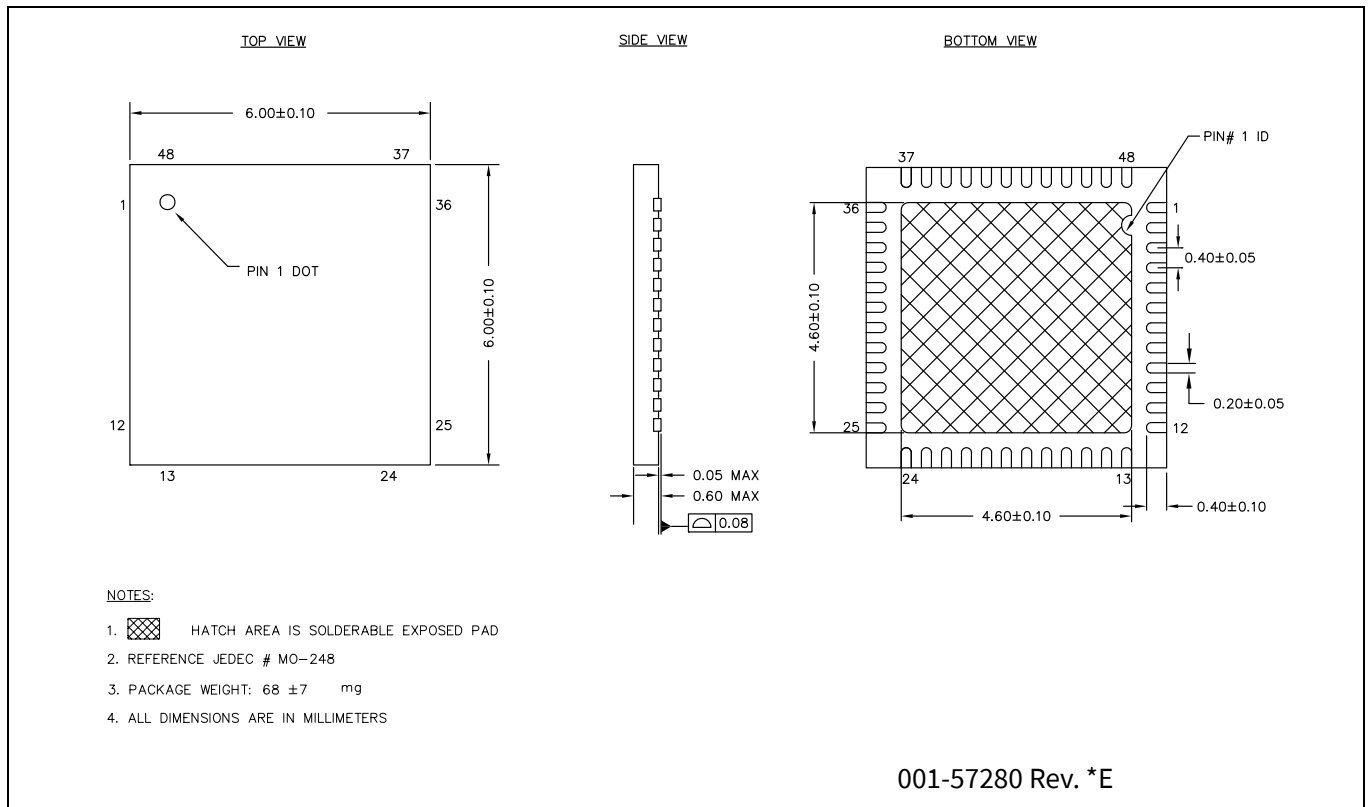

Figure 7 48-pin TQFP (7 × 7 × 1.4 mm) A48 package outline (PG-TQFP-48), 51-85135



**Figure 8 48-pin QFN ((6 × 6 × 0.6 mm) LR48A/LQ48A 4.6 × 4.6 E-Pad (Sawn)) package outline (PG-VQFN-48), 001-57280**

**Note:**

The center pad on the QFN package should be connected to ground (VSS) for best mechanical, thermal, and electrical performance. If not connected to ground, it should be electrically floating and not connected to any other signal.

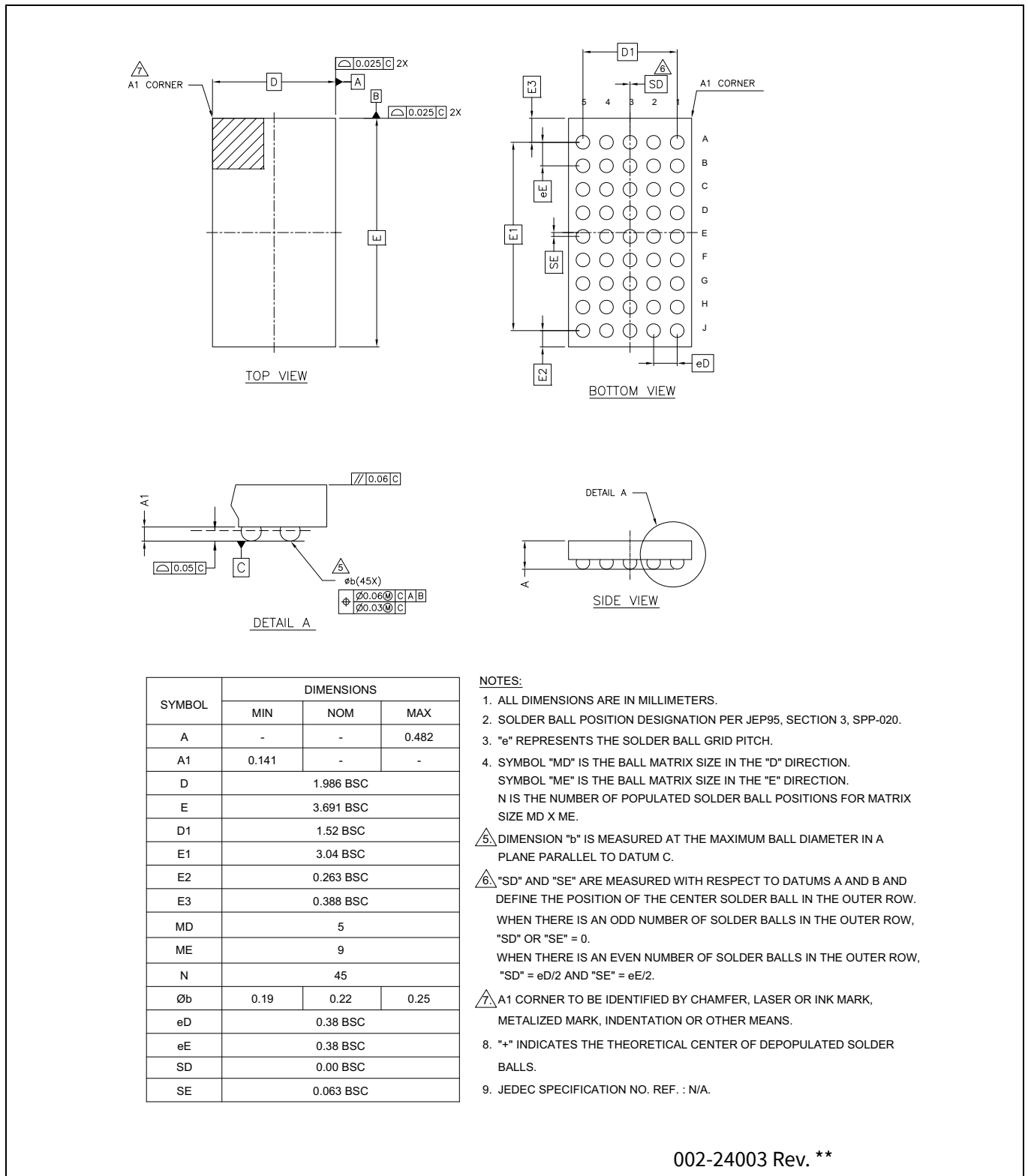

**Figure 9 45-ball WLCSP (1.986 × 3.691 × 0.482 mm) FN45B package outline (SG-XFWLB-45), 002-24003**

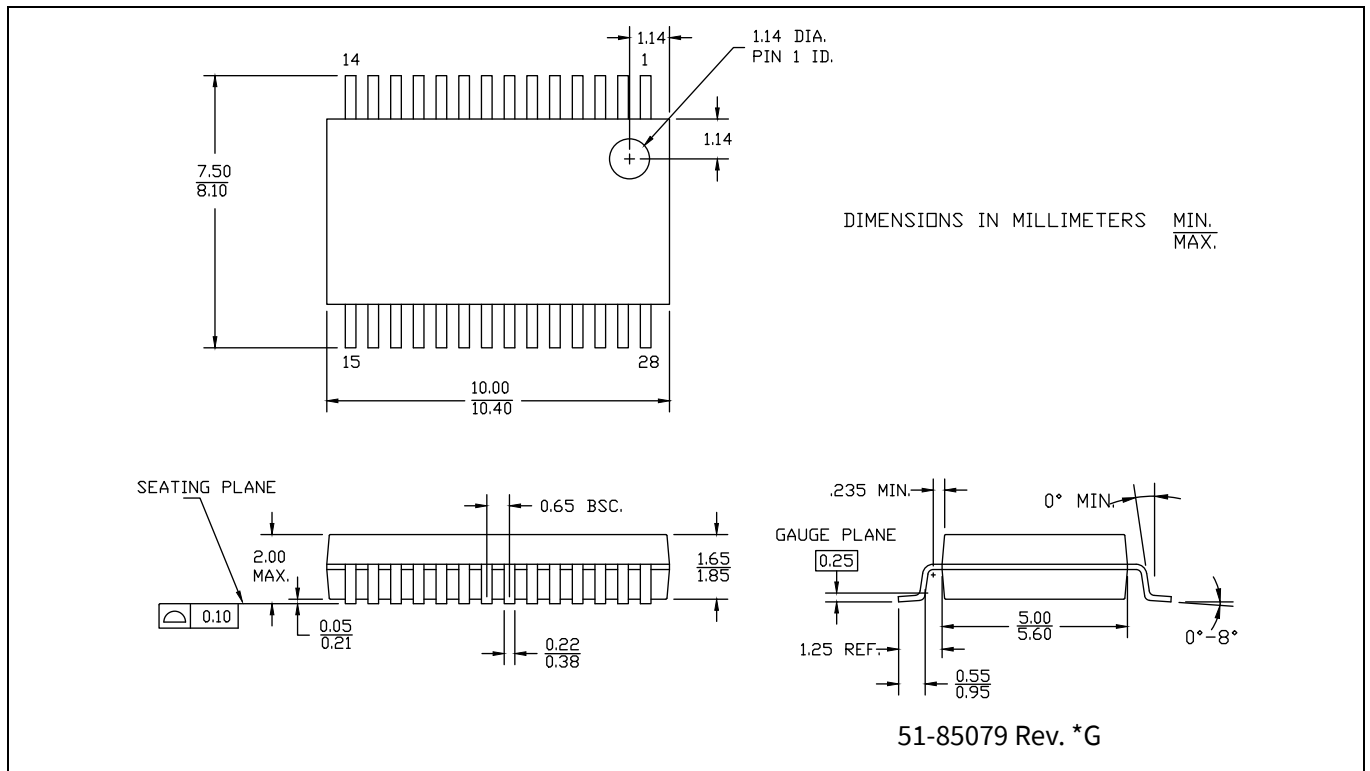

**Figure 10 28-pin SSOP (10.2 × 5.3 × 2.0 mm) SP28 package outline (PG-SSOP-28), 51-85079**

## 9 Acronyms

**Table 47 Acronyms used in this document**

<b>Acronym</b>	<b>Description</b>
abus	analog local bus
ADC	analog-to-digital converter
AG	analog global
AHB	AMBA (advanced microcontroller bus architecture) high-performance bus, an Arm® data transfer bus
ALU	arithmetic logic unit
AMUXBUS	analog multiplexer bus
API	application programming interface
APSR	application program status register
Arm®	advanced RISC machine, a CPU architecture
ATM	automatic thump mode
BW	bandwidth
CAN	Controller Area Network, a communications protocol
CMRR	common-mode rejection ratio
CPU	central processing unit
CRC	cyclic redundancy check, an error-checking protocol
DAC	digital-to-analog converter, see also IDAC, VDAC
DFB	digital filter block
DIO	digital input/output, GPIO with only digital capabilities, no analog. See GPIO.
DMIPS	Dhrystone million instructions per second
DMA	direct memory access, see also TD
DNL	differential nonlinearity, see also INL
DNU	do not use
DR	port write data registers
DSI	digital system interconnect
DWT	data watchpoint and trace
ECC	error correcting code
ECO	external crystal oscillator
EEPROM	electrically erasable programmable read-only memory
EMI	electromagnetic interference
EMIF	external memory interface
EOC	end of conversion
EOF	end of frame
EPSR	execution program status register
ESD	electrostatic discharge
ETM	embedded trace macrocell
FIR	finite impulse response, see also IIR

Acronyms

**Table 47** Acronyms used in this document *(continued)*

Acronym	Description
FPB	flash patch and breakpoint
FS	full-speed
GPIO	general-purpose input/output, applies to a PSoC pin
HVI	high-voltage interrupt, see also LVI, LVD
IC	integrated circuit
IDAC	current DAC, see also DAC, VDAC
IDE	integrated development environment
I <sup>2</sup> C, or IIC	Inter-Integrated Circuit, a communications protocol
IIR	infinite impulse response, see also FIR
ILO	internal low-speed oscillator, see also IMO
IMO	internal main oscillator, see also ILO
INL	integral nonlinearity, see also DNL
I/O	input/output, see also GPIO, DIO, SIO, USBIO
IPOR	initial power-on reset
IPSR	interrupt program status register
IRQ	interrupt request
ITM	instrumentation trace macrocell
LCD	liquid crystal display
LIN	Local Interconnect Network, a communications protocol.
LR	link register
LUT	lookup table
LVD	low-voltage detect, see also LVI
LVI	low-voltage interrupt, see also HVI
LVTTL	low-voltage transistor-transistor logic
MAC	multiply-accumulate
MCU	microcontroller unit
MISO	master-in slave-out
NC	no connect
NMI	nonmaskable interrupt
NRZ	non-return-to-zero
NVIC	nested vectored interrupt controller
NVL	nonvolatile latch, see also WOL
opamp	operational amplifier
PAL	programmable array logic, see also PLD
PC	program counter
PCB	printed circuit board
PGA	programmable gain amplifier
PHUB	peripheral hub
PHY	physical layer
PICU	port interrupt control unit

Acronyms

**Table 47** Acronyms used in this document *(continued)*

Acronym	Description
PLA	programmable logic array
PLD	programmable logic device, see also PAL
PLL	phase-locked loop
PMDD	package material declaration data sheet
POR	power-on reset
PRES	precise power-on reset
PRS	pseudo random sequence
PS	port read data register
PSoC™	Programmable System-on-Chip™
PSRR	power supply rejection ratio
PWM	pulse-width modulator
RAM	random-access memory
RISC	reduced-instruction-set computing
RMS	root-mean-square
RTC	real-time clock
RTL	register transfer language
RTR	remote transmission request
RX	receive
SAR	successive approximation register
SC/CT	switched capacitor/continuous time
SCL	I <sup>2</sup> C serial clock
SDA	I <sup>2</sup> C serial data
S/H	sample and hold
SINAD	signal to noise and distortion ratio
SIO	special input/output, GPIO with advanced features. See GPIO.
SOC	start of conversion
SOF	start of frame
SPI	Serial Peripheral Interface, a communications protocol
SR	slew rate
SRAM	static random access memory
SRES	software reset
SWD	serial wire debug, a test protocol
SWV	single-wire viewer
TD	transaction descriptor, see also DMA
THD	total harmonic distortion
TIA	transimpedance amplifier
TRM	technical reference manual
TTL	transistor-transistor logic
TX	transmit
UART	Universal Asynchronous Transmitter Receiver, a communications protocol

Acronyms

**Table 47**      **Acronyms used in this document** *(continued)*

<b>Acronym</b>	<b>Description</b>
UDB	universal digital block
USB	Universal Serial Bus
USBIO	USB input/output, PSoC pins used to connect to a USB port
VDAC	voltage DAC, see also DAC, IDAC
WDT	watchdog timer
WOL	write once latch, see also NVL
WRES	watchdog timer reset
XRES	external reset I/O pin
XTAL	crystal

## 10 Document conventions

### 10.1 Units of measure

**Table 48** Units of measure

Symbol	Unit of measure
°C	degrees Celsius
dB	decibel
fF	femto farad
Hz	hertz
KB	1024 bytes
kbps	kilobits per second
Khr	kilohour
kHz	kilohertz
kΩ	kilo ohm
ksps	kilosamples per second
LSB	least significant bit
Mbps	megabits per second
MHz	megahertz
MΩ	mega-ohm
Msps	megasamples per second
μA	microampere
μF	microfarad
μH	microhenry
μs	microsecond
μV	microvolt
μW	microwatt
mA	milliampere
ms	millisecond
mV	millivolt
nA	nanoampere
ns	nanosecond
nV	nanovolt
Ω	ohm
pF	picofarad
ppm	parts per million
ps	picosecond
s	second
sps	samples per second
sqrtHz	square root of hertz
V	volt

## Revision history

Document revision	Date	Description of changes
**	2018-01-30	New spec.
*A	2018-04-27	Updated <b>Functional definition</b> : Updated <b>Analog blocks</b> : Updated <b>VDAC (13 bits)</b> : Updated description. Updated <b>Electrical specifications</b> : Updated <b>Analog peripherals</b> : Updated <b>Voltage DAC</b> : Updated <b>Table 12</b> .
*B	2018-05-03	Updated <b>Ordering information</b> : No change in part numbers. Fixed typo.
*C	2018-09-25	Updated <b>Electrical specifications</b> : Updated <b>Device Level Specifications</b> : Updated <b>Table 4</b> . Updated <b>XRES</b> : Updated <b>Table 8</b> . Updated <b>Analog peripherals</b> : Updated <b>CTB Opamp</b> : Updated <b>Table 10</b> . Updated <b>Voltage DAC</b> : Updated <b>Table 12</b> . Updated <b>Memory</b> : Updated <b>Flash</b> : Updated <b>Table 29</b> . Updated <b>System resources</b> : Updated <b>External Clock</b> : Updated <b>Table 38</b> . Updated <b>Packaging</b> : Updated <b>Package diagrams</b> : Removed spec 002-10531 Rev. **. Added spec 002-24003 Rev. **.
*D	2019-12-06	Updated <b>Electrical specifications</b> : Updated <b>Device Level Specifications</b> : Updated description. Updated <b>Memory</b> : Updated <b>Flash</b> : Updated <b>Table 29</b> . Updated <b>Ordering information</b> : Updated <b>Table 41</b> (Updated part numbers). Updated <b>Packaging</b> : Updated <b>Table 44</b> . Updated to new template.

Revision history

Document revision	Date	Description of changes
*E	2020-12-17	Updated <b>Electrical specifications</b> : Updated <b>System resources</b> : Updated <b>Power-on Reset (POR)</b> : Updated <b>Table 30</b> . Updated <b>Packaging</b> : Updated <b>Package diagrams</b> : spec 51-85079 – Changed revision from *F to *G. Updated to new template.
*F	2023-11-16	Updated Document Title to read as “CY8C41x5, PSoC™ 4100PS Based on Arm® Cortex™-M0+”. Updated <b>More information</b> : Updated description. Updated hyperlinks. Updated <b>PSoC™ Creator</b> : Updated hyperlinks. Updated <b>Development support</b> : Updated hyperlinks. Updated <b>Packaging</b> : Updated <b>Package diagrams</b> : No change in revisions. Added Note below spec 001-57280 *E. Migrated to Infineon template. Completing Sunset Review.

## Trademarks

All referenced product or service names and trademarks are the property of their respective owners.

**Edition 2023-11-16**

**Published by**

**Infineon Technologies AG  
81726 Munich, Germany**

**© 2023 Infineon Technologies AG.  
All Rights Reserved.**

**Do you have a question about this document?**

**Email:**  
[erratum@infineon.com](mailto:erratum@infineon.com)

**Document reference  
002-22097 Rev. \*F**

## IMPORTANT NOTICE

The information given in this document shall in no event be regarded as a guarantee of conditions or characteristics ("Beschaffenheitsgarantie").

With respect to any examples, hints or any typical values stated herein and/or any information regarding the application of the product, Infineon Technologies hereby disclaims any and all warranties and liabilities of any kind, including without limitation warranties of non-infringement of intellectual property rights of any third party.

In addition, any information given in this document is subject to customer's compliance with its obligations stated in this document and any applicable legal requirements, norms and standards concerning customer's products and any use of the product of Infineon Technologies in customer's applications.

The data contained in this document is exclusively intended for technically trained staff. It is the responsibility of customer's technical departments to evaluate the suitability of the product for the intended application and the completeness of the product information given in this document with respect to such application.

## WARNINGS

Due to technical requirements products may contain dangerous substances. For information on the types in question please contact your nearest Infineon Technologies office.

Except as otherwise explicitly approved by Infineon Technologies in a written document signed by authorized representatives of Infineon Technologies, Infineon Technologies' products may not be used in any applications where a failure of the product or any consequences of the use thereof can reasonably be expected to result in personal injury.

## Looking for pricing, stock, or lifecycle information?

Click below to explore more details on WIN SOURCE:

- [View CY8C4145AZI-PS433 on WIN SOURCE](#)
- [Cypress Semiconductor Corp Information](#)

## Optimize Your Supply Chain with WIN SOURCE Solutions

- ✓ Global Sourcing Solution
- ✓ Obsolete Management
- ✓ Cost Control Management
- ✓ Shortage Management
- ✓ Alternative Solution
- ✓ Excess Inventory Management