



**THE DATASHEET OF
HPC3130APGE**



- **Compliant With PCI Hot-Plug Specification, Revision 1.0**
- **Supports up to Four Independently Controlled Hot-Plug Slots**
- **Provides Register Accessing Through Both Generic Parallel Bus and Two-Wire Serial Interface**
- **Provides Interrupt and Event Status/Enable State Compliant With ACPI Specification 1.0**
- **Provides an Automatic Bus Connection Sequencing Feature**
- **Supports 66-MHz PCI Clock Frequency**
- **Features Two Attention Indicators With Variable LED Blinking Rates per Slot**
- **Provides an Easy Scheme to Cascade the HPC3130A for Compact PCI Applications**
- **Provides Card Detection Mechanism Independent of PCI Present Signals for Advanced Card Protection**
- **Provides Path to Guarantee Idle State During PCI Bus Connections**
- **Fabricated in Advanced Low-Power CMOS Process**
- **Features a CBT Switch† Control Feature for REQ64 Implementation**
- **Package Options:**
 - 120-pin QFP Package
 - 128-pin LQFP Package
 - 144-pin LQFP Package

Table of Contents

Description	2	66 MHz PCI Support	24
Functional Block Diagram	2	Configuration and Control Registers	25
Pin Assignments (120-Pin)	3	Absolute Maximum Ratings	32
Pin Assignments (128-Pin)	4	Recommended Operating Conditions	33
Pin Assignments (144-Pin)	5	Serial Bus Interface	34
Signal Name/Pin Number Sort Table (120-Pin)	6	Electrical Characteristics	34
Signal Name/Pin Number Sort Table (128-Pin)	8	PCI Clock/Reset Timing Requirements	35
Signal Name/Pin Number Sort Table (144-Pin)	10	PCI Timing Requirements	36
Terminal Functions	12	Mechanical Data (120-Pin)	37
HPC3130A Applications	15	Mechanical Data (128-Pin)	38
64-Bit Implementation	23	Mechanical Data (144-Pin)	39



Please be aware that an important notice concerning availability, standard warranty, and use in critical applications of Texas Instruments semiconductor products and disclaimers thereto appears at the end of this data sheet.

† Contact Texas Instrument's Bus Interface product group for information related to CBT switches.

PRODUCTION DATA information is current as of publication date. Products conform to specifications per the terms of Texas Instruments standard warranty. Production processing does not necessarily include testing of all parameters.



POST OFFICE BOX 655303 • DALLAS, TEXAS 75265

Copyright © 1999, Texas Instruments Incorporated

HPC3130A PCI HOT PLUG CONTROLLER

SCPS055 – NOVEMBER 1999

description

The Texas Instruments HPC3130A is a peripheral component interconnect (PCI) hot-plug controller, compliant with *PCI Hot-Plug Specification, Revision 1.0*. This device supports hot insertion/removal of up to four hot-plug slots on a PCI bus, provides a 64-bit data path in any of the four hot-plug slots, and supports 66-MHz systems for two slots.

The primary function of the HPC3130A is to allow noninterfering hot-plug slot connection/disconnection with the other PCI devices on the bus. The HPC3130A provides automatic bus connection sequencing and supports a protocol for connection during bus idle conditions. It also supports an interrupt pin to report hot-plug slot events. The interrupt event status and enable state are compliant with the *Advanced Configuration and Power Interface (ACPI) Specification*.

Internal registers may be accessed through either a two-signal serial interface or a generic parallel bus. The serial interface slave decoding circuit supports up to eight different controllers or other serial bus devices with the same system base. Decoding through the parallel interface supports multiple controllers with external chip-select logic. Two double-words of configuration and control registers are provided per slot. As a result, the HPC3130A decodes an address range of 32 bytes.

An advanced complementary metal-oxide semiconductor (CMOS) process provides low system power consumption while operating at PCI clock rates up to 66 MHz.

functional block diagram

A simplified block diagram of the HPC3130A is provided below. The block diagram illustrates the HPC3130A functionality on a per slot basis. The SMODE chip input, not shown, is used for terminal multiplexing of the serial and parallel bus slave interfaces.

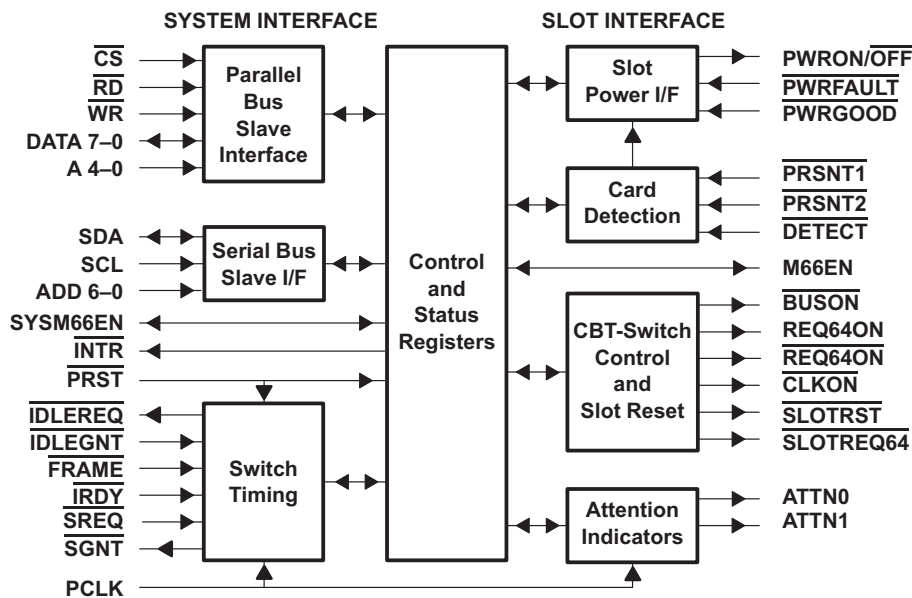

terminal assignments (120-terminal package)

PBM QUAD FLAT PACKAGE
TOP VIEW

Pin	Signal	Pin	Signal
1	ATTN0[3]	90	RSVD
2	ATTN1[3]	89	RSVD
3	M66EN[3]	88	DETECT1[1]
4	DETECT0[3]	87	DETECT0[1]
5	DETECT1[3]	86	M66EN[1]
6	V _{CC}	85	V _{CC}
7	SLOTREQ64[3]	84	ATTN1[1]
8	SLOTREQ64[2]	83	ATTN0[1]
9	SLOTREQ64[1]	82	CLKON[1]
10	SLOTREQ64[0]	81	BUSON[1]
11	GND	80	REQ64ON[1]
12	SREQ	79	GND
13	SGNT	78	REQ64ON[1]
14	PRST	77	SLOTTRST[1]
15	V _{CC5V}	76	PRSNT2[1]
16	PCLK	75	PRSNT1[1]
17	GND	74	V _{CC5V}
18	IDLEREQ	73	PWRGOOD[1]
19	IDLEGNT	72	PWRFAULT[1]
20	FRAME	71	PWRON/OFF[1]
21	IRDY	70	DETECT1[0]
22	V _{CCP}	69	DETECT0[0]
23	INTR	68	GND
24	INTR	67	M66EN[0]
25	SYSM66EN	66	ATTN1[0]
26	GND	65	ATTN0[0]
27	SMODE	64	CLKON[0]
28	V _{CC5V}	63	BUSON[0]
29	RD/SDA	62	RSVD
30	WR/SCL	61	RSVD
31	RSVD	51	GND
32	RSVD	52	PWRON/OFF[0]
33	RSVD	53	PWRFAULT[0]
34	CS	54	PWRGOOD[0]
35	DATA7	55	PRSNT1[0]
36	V _{CC}	56	V _{CC}
37	DATA6	57	PRSNT2[0]
38	DATA5	58	SLOTTRST[0]
39	DATA4	59	REQ64ON[0]
40	DATA3	60	REQ64ON[0]
41	GND		
42	DATA2		
43	DATA1/ADD6		
44	DATA0/ADD5		
45	A4/ADD4		
46	V _{CC5V}		
47	A3/ADD3		
48	A2/ADD2		
49	A1/ADD1		
50	A0/ADD0		
51	GND		
52	PWRON/OFF[0]		
53	PWRFAULT[0]		
54	PWRGOOD[0]		
55	PRSNT1[0]		
56	V _{CC}		
57	PRSNT2[0]		
58	SLOTTRST[0]		
59	REQ64ON[0]		
60	REQ64ON[0]		
61	RSVD		
62	RSVD		
63	BUSON[0]		
64	CLKON[0]		
65	ATTN0[0]		
66	ATTN1[0]		
67	M66EN[0]		
68	GND		
69	DETECT0[0]		
70	DETECT1[0]		
71	PWRON/OFF[1]		
72	PWRFAULT[1]		
73	PWRGOOD[1]		
74	V _{CC5V}		
75	PRSNT1[1]		
76	PRSNT2[1]		
77	SLOTTRST[1]		
78	REQ64ON[1]		
79	GND		
80	REQ64ON[1]		
81	BUSON[1]		
82	CLKON[1]		
83	ATTN0[1]		
84	ATTN1[1]		
85	V _{CC}		
86	M66EN[1]		
87	DETECT0[1]		
88	DETECT1[1]		
89	RSVD		
90	RSVD		
91	PWRON/OFF[2]		
92	PWRFAULT[2]		
93	PWRGOOD[2]		
94	PRSNT1[2]		
95	V _{CC}		
96	PRSNT2[2]		
97	SLOTTRST[2]		
98	REQ64ON[2]		
99	REQ64ON[2]		
100	BUSON[2]		
101	GND		
102	CLKON[2]		
103	ATTN0[2]		
104	ATTN1[2]		
105	M66EN[2]		
106	DETECT0[2]		
107	V _{CC5V}		
108	DETECT1[2]		
109	PWRON/OFF[3]		
110	PWRFAULT[3]		
111	PWRGOOD[3]		
112	GND		
113	PRSNT1[3]		
114	PRSNT2[3]		
115	SLOTTRST[3]		
116	REQ64ON[3]		
117	GND		
118	REQ64ON[3]		
119	BUSON[3]		
120	CLKON[3]		

HPC3130A PCI HOT PLUG CONTROLLER

SCPS055 – NOVEMBER 1999

terminal assignments (128-terminal package)

PBK LOW-PROFILE QUAD FLAT PACKAGE
TOP VIEW

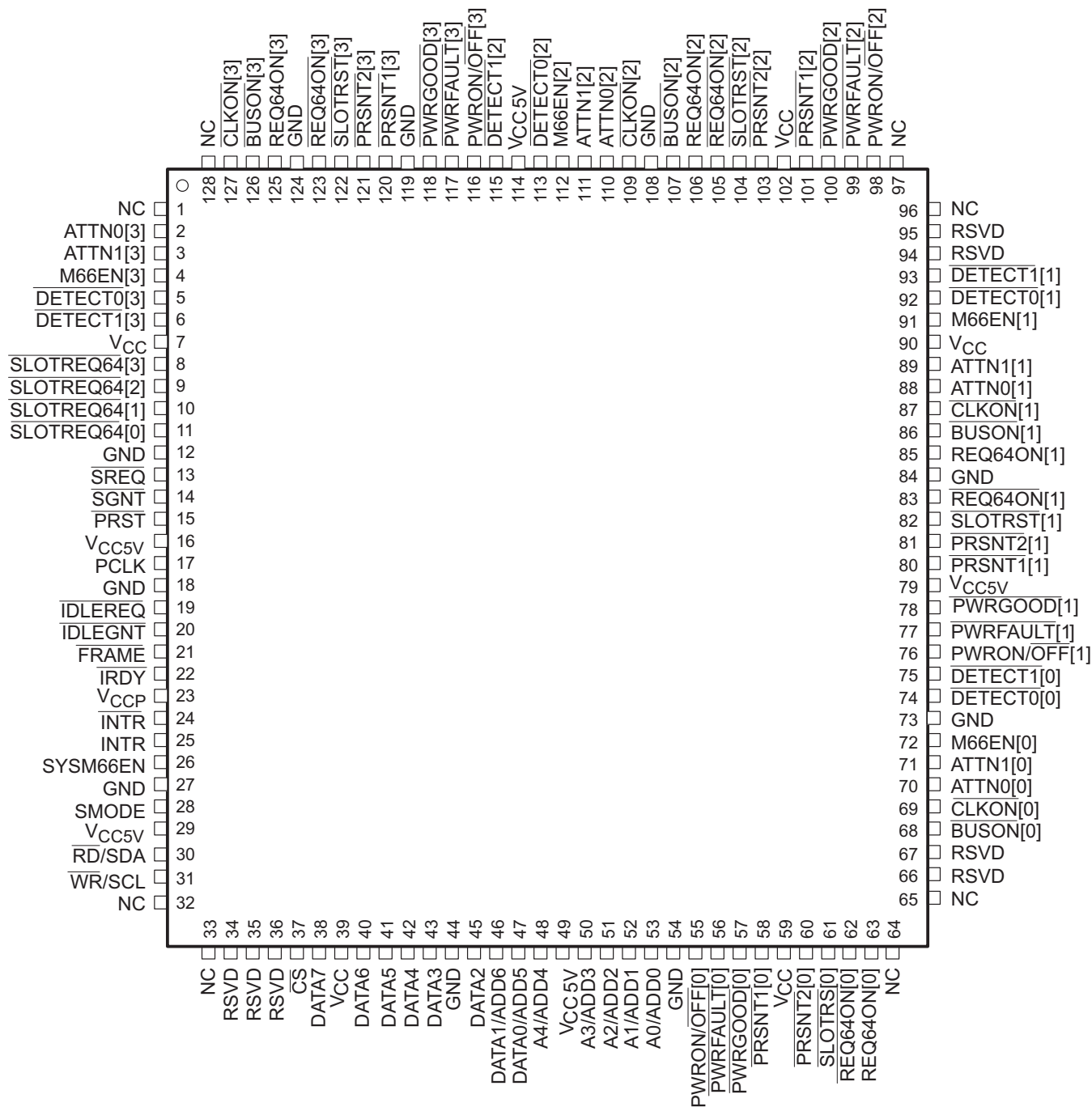

POST OFFICE BOX 655303 • DALLAS, TEXAS 75265

terminal assignments (144-terminal package)

PGE LOW-PROFILE QUAD FLAT PACKAGE TOP VIEW

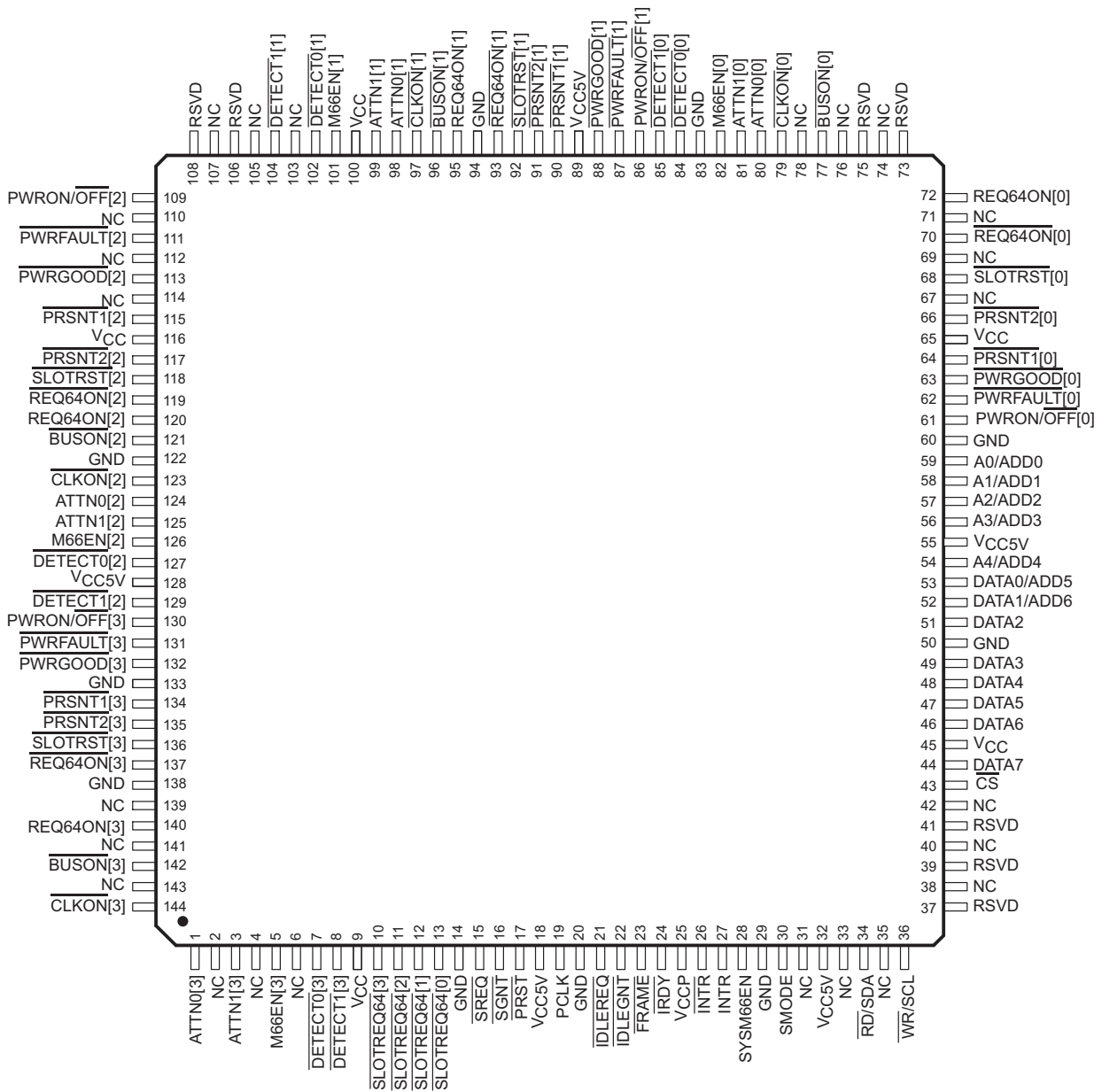

HPC3130A PCI HOT PLUG CONTROLLER

SCPS055 – NOVEMBER 1999

signal names by terminal name

Table 1. Signals Sorted Alphabetically by Terminal Name (120-Terminal Package)

TERMINAL NAME	NO.	TERMINAL NAME	NO.	TERMINAL NAME	NO.
A0/ADD0	50	GND	17	$\overline{\text{RD}}/\text{SDA}$	29
A1/ADD1	49	GND	26	$\overline{\text{REQ64ON}}[0]$	59
A2/ADD2	48	GND	41	$\overline{\text{REQ64ON}}[1]$	78
A3/ADD3	47	GND	51	$\overline{\text{REQ64ON}}[2]$	98
A4/ADD4	45	GND	68	$\overline{\text{REQ64ON}}[3]$	116
ATTN0[0]	65	GND	79	REQ64ON[0]	60
ATTN0[1]	83	GND	101	REQ64ON[1]	80
ATTN0[2]	103	GND	112	REQ64ON[2]	99
ATTN0[3]	1	GND	117	REQ64ON[3]	118
ATTN1[0]	66	$\overline{\text{IDLEGNT}}$	19	RSVD	31
ATTN1[1]	84	$\overline{\text{IDLEREQ}}$	18	RSVD	32
ATTN1[2]	104	INTR	24	RSVD	33
ATTN1[3]	2	$\overline{\text{INTR}}$	23	RSVD	61
$\overline{\text{BUSON}}[0]$	63	$\overline{\text{IRDY}}$	21	RSVD	62
$\overline{\text{BUSON}}[1]$	81	M66EN[0]	67	RSVD	89
$\overline{\text{BUSON}}[2]$	100	M66EN[1]	86	RSVD	90
$\overline{\text{BUSON}}[3]$	119	M66EN[2]	105	$\overline{\text{SGNT}}$	13
$\overline{\text{CLKON}}[0]$	64	M66EN[3]	3	$\overline{\text{SLOTREQ64}}[0]$	10
$\overline{\text{CLKON}}[1]$	82	PCLK	16	$\overline{\text{SLOTREQ64}}[1]$	9
$\overline{\text{CLKON}}[2]$	102	$\overline{\text{PRSNT1}}[0]$	55	$\overline{\text{SLOTREQ64}}[2]$	8
$\overline{\text{CLKON}}[3]$	120	$\overline{\text{PRSNT1}}[1]$	75	$\overline{\text{SLOTREQ64}}[3]$	7
$\overline{\text{CS}}$	34	$\overline{\text{PRSNT1}}[2]$	94	$\overline{\text{SLOTTRST}}[0]$	58
DATA0/ADD5	44	$\overline{\text{PRSNT1}}[3]$	113	$\overline{\text{SLOTTRST}}[1]$	77
DATA1/ADD6	43	$\overline{\text{PRSNT2}}[0]$	57	$\overline{\text{SLOTTRST}}[2]$	97
DATA2	42	$\overline{\text{PRSNT2}}[1]$	76	$\overline{\text{SLOTTRST}}[3]$	115
DATA3	40	$\overline{\text{PRSNT2}}[2]$	96	SMODE	27
DATA4	39	$\overline{\text{PRSNT2}}[3]$	114	$\overline{\text{SREQ}}$	12
DATA5	38	$\overline{\text{PRST}}$	14	SYSM66EN	25
DATA6	37	$\overline{\text{PWRFAULT}}[0]$	53	VCC	6
DATA7	35	$\overline{\text{PWRFAULT}}[1]$	72	VCC	36
$\overline{\text{DETECT0}}[0]$	69	$\overline{\text{PWRFAULT}}[2]$	92	VCC	56
$\overline{\text{DETECT0}}[1]$	87	$\overline{\text{PWRFAULT}}[3]$	110	VCC	85
$\overline{\text{DETECT0}}[2]$	106	$\overline{\text{PWRGOOD}}[0]$	54	VCC	95
$\overline{\text{DETECT0}}[3]$	4	$\overline{\text{PWRGOOD}}[1]$	73	VCC5V	15
$\overline{\text{DETECT1}}[0]$	70	$\overline{\text{PWRGOOD}}[2]$	93	VCC5V	28
$\overline{\text{DETECT1}}[1]$	88	$\overline{\text{PWRGOOD}}[3]$	111	VCC5V	46
$\overline{\text{DETECT1}}[2]$	108	PWRON/OFF[0]	52	VCC5V	74
$\overline{\text{DETECT1}}[3]$	5	PWRON/OFF[1]	71	VCC5V	107
FRAME	20	PWRON/OFF[2]	91	VCCP	22
GND	11	PWRON/OFF[3]	109	$\overline{\text{WR}}/\text{SCL}$	30



signal names by terminal number

Table 2. Signals Sorted Numerically by Terminal Number (120-Terminal Package)

NO.	TERMINAL NAME	NO.	TERMINAL NAME	NO.	TERMINAL NAME
1	ATTN0[3]	41	GND	81	BUSON[1]
2	ATTN1[3]	42	DATA2	82	CLKON[1]
3	M66EN[3]	43	DATA1/ADD6	83	ATTN0[1]
4	DETECT0[3]	44	DATA0/ADD5	84	ATTN1[1]
5	DETECT1[3]	45	A4/ADD4	85	VCC
6	VCC	46	VCC5V	86	M66EN[1]
7	SLOTREQ64[3]	47	A3/ADD3	87	DETECT0[1]
8	SLOTREQ64[2]	48	A2/ADD2	88	DETECT1[1]
9	SLOTREQ64[1]	49	A1/ADD1	89	RSVD
10	SLOTREQ64[0]	50	A0/ADD0	90	RSVD
11	GND	51	GND	91	PWRON/OFF[2]
12	SREQ	52	PWRON/OFF[0]	92	PWRFAULT[2]
13	SGNT	53	PWRFAULT[0]	93	PWRGOOD[2]
14	PRST	54	PWRGOOD[0]	94	PRSNT1[2]
15	VCC5V	55	PRSNT1[0]	95	VCC
16	PCLK	56	VCC	96	PRSNT2[2]
17	GND	57	PRSNT2[0]	97	SLOTTRST[2]
18	IDLEREQ	58	SLOTTRST[0]	98	REQ64ON[2]
19	IDLEGNT	59	REQ64ON[0]	99	REQ64ON[2]
20	FRAME	60	REQ64ON[0]	100	BUSON[2]
21	IRDY	61	RSVD	101	GND
22	VCCP	62	RSVD	102	CLKON[2]
23	INTR	63	BUSON[0]	103	ATTN0[2]
24	INTR	64	CLKON[0]	104	ATTN1[2]
25	SYM66EN	65	ATTN0[0]	105	M66EN[2]
26	GND	66	ATTN1[0]	106	DETECT0[2]
27	SMODE	67	M66EN[0]	107	VCC5V
28	VCC5V	68	GND	108	DETECT1[2]
29	RD/SDA	69	DETECT0[0]	109	PWRON/OFF[3]
30	WR/SCL	70	DETECT1[0]	110	PWRFAULT[3]
31	RSVD	71	PWRON/OFF[1]	111	PWRGOOD[3]
32	RSVD	72	PWRFAULT[1]	112	GND
33	RSVD	73	PWRGOOD[1]	113	PRSNT1[3]
34	CS	74	VCC5V	114	PRSNT2[3]
35	DATA7	75	PRSNT1[1]	115	SLOTTRST[3]
36	VCC	76	PRSNT2[1]	116	REQ64ON[3]
37	DATA6	77	SLOTTRST[1]	117	GND
38	DATA5	78	REQ64ON[1]	118	REQ64ON[3]
39	DATA4	79	GND	119	BUSON[3]
40	DATA3	80	REQ64ON[1]	120	CLKON[3]

HPC3130A PCI HOT PLUG CONTROLLER

SCPS055 – NOVEMBER 1999

signal names by terminal name

Table 3. Signals Sorted Alphabetically by Terminal Name (128-Terminal Package)

TERMINAL NAME	NO.	TERMINAL NAME	NO.	TERMINAL NAME	NO.	TERMINAL NAME	NO.
A0/ADD0	53	$\overline{\text{DETECT0}}[2]$	113	NC	97	REQ64ON[3]	125
A1/ADD1	52	$\overline{\text{DETECT0}}[3]$	5	NC	128	RSVD	34
A2/ADD2	51	$\overline{\text{DETECT1}}[0]$	75	PCLK	17	RSVD	35
A3/ADD3	50	$\overline{\text{DETECT1}}[1]$	93	$\overline{\text{PRSNT1}}[0]$	58	RSVD	36
A4/ADD4	48	$\overline{\text{DETECT1}}[2]$	115	$\overline{\text{PRSNT1}}[1]$	80	RSVD	66
ATTN0[0]	70	$\overline{\text{DETECT1}}[3]$	6	$\overline{\text{PRSNT1}}[2]$	101	RSVD	67
ATTN0[1]	88	$\overline{\text{FRAME}}$	21	$\overline{\text{PRSNT1}}[3]$	120	RSVD	94
ATTN0[2]	110	GND	12	$\overline{\text{PRSNT2}}[0]$	60	RSVD	95
ATTN0[3]	2	GND	18	$\overline{\text{PRSNT2}}[1]$	81	$\overline{\text{SGNT}}$	14
ATTN1[0]	71	GND	27	$\overline{\text{PRSNT2}}[2]$	103	$\overline{\text{SLOTREQ64}}[0]$	11
ATTN1[1]	89	GND	44	$\overline{\text{PRSNT2}}[3]$	121	$\overline{\text{SLOTREQ64}}[1]$	10
ATTN1[2]	111	GND	54	$\overline{\text{PRST}}$	15	$\overline{\text{SLOTREQ64}}[2]$	9
ATTN1[3]	3	GND	73	$\overline{\text{PWRFAULT}}[0]$	56	$\overline{\text{SLOTREQ64}}[3]$	8
$\overline{\text{BUSON}}[0]$	68	GND	84	$\overline{\text{PWRFAULT}}[1]$	77	$\overline{\text{SLOTTRST}}[0]$	61
$\overline{\text{BUSON}}[1]$	86	GND	108	$\overline{\text{PWRFAULT}}[2]$	99	$\overline{\text{SLOTTRST}}[1]$	82
$\overline{\text{BUSON}}[2]$	107	GND	119	$\overline{\text{PWRFAULT}}[3]$	117	$\overline{\text{SLOTTRST}}[2]$	104
$\overline{\text{BUSON}}[3]$	126	GND	124	$\overline{\text{PWRGOOD}}[0]$	57	$\overline{\text{SLOTTRST}}[3]$	122
$\overline{\text{CLKON}}[0]$	69	$\overline{\text{IDLEGN}}[T]$	20	$\overline{\text{PWRGOOD}}[1]$	78	SMODE	28
$\overline{\text{CLKON}}[1]$	87	$\overline{\text{IDLEREQ}}$	19	$\overline{\text{PWRGOOD}}[2]$	100	$\overline{\text{SREQ}}$	13
$\overline{\text{CLKON}}[2]$	109	INTR	25	$\overline{\text{PWRGOOD}}[3]$	118	SYSM66EN	26
$\overline{\text{CLKON}}[3]$	127	$\overline{\text{INTR}}$	24	PWRON/ $\overline{\text{OFF}}$ [0]	55	VCC	7
$\overline{\text{CS}}$	37	$\overline{\text{IRDY}}$	22	PWRON/ $\overline{\text{OFF}}$ [1]	76	VCC	39
DATA0/ADD5	47	M66EN[0]	72	PWRON/ $\overline{\text{OFF}}$ [2]	98	VCC	59
DATA1/ADD6	46	M66EN[1]	91	PWRON/ $\overline{\text{OFF}}$ [3]	116	VCC	90
DATA2	45	M66EN[2]	112	$\overline{\text{RD}}/\text{SDA}$	30	VCC	102
DATA3	43	M66EN[3]	4	$\overline{\text{REQ64ON}}[0]$	62	VCC5V	16
DATA4	42	NC	1	$\overline{\text{REQ64ON}}[1]$	83	VCC5V	29
DATA5	41	NC	32	$\overline{\text{REQ64ON}}[2]$	105	VCC5V	49
DATA6	40	NC	33	$\overline{\text{REQ64ON}}[3]$	123	VCC5V	79
DATA7	38	NC	64	REQ64ON[0]	63	VCC5V	114
$\overline{\text{DETECT0}}[0]$	74	NC	65	REQ64ON[1]	85	VCCP	23
$\overline{\text{DETECT0}}[1]$	92	NC	96	REQ64ON[2]	106	$\overline{\text{WR/SCL}}$	31



signal names by terminal number

Table 4. Signals Sorted Numerically by Terminal Number (128-Terminal Package)

NO.	TERMINAL NAME	NO.	TERMINAL NAME	NO.	TERMINAL NAME	NO.	TERMINAL NAME
1	NC	33	NC	65	NC	97	NC
2	ATTN0[3]	34	RSVD	66	RSVD	98	PWRON/OFF[2]
3	ATTN1[3]	35	RSVD	67	RSVD	99	PWRFAULT[2]
4	M66EN[3]	36	RSVD	68	BUSON[0]	100	PWRGOOD[2]
5	DETECT0[3]	37	CS	69	CLKON[0]	101	PRSNT1[2]
6	DETECT1[3]	38	DATA7	70	ATTN0[0]	102	VCC
7	VCC	39	VCC	71	ATTN1[0]	103	PRSNT2[2]
8	SLOTREQ64[3]	40	DATA6	72	M66EN[0]	104	SLOTTRST[2]
9	SLOTREQ64[2]	41	DATA5	73	GND	105	REQ64ON[2]
10	SLOTREQ64[1]	42	DATA4	74	DETECT0[0]	106	REQ64ON[2]
11	SLOTREQ64[0]	43	DATA3	75	DETECT1[0]	107	BUSON[2]
12	GND	44	GND	76	PWRON/OFF[1]	108	GND
13	SREQ	45	DATA2	77	PWRFAULT[1]	109	CLKON[2]
14	SGNT	46	DATA1/ADD6	78	PWRGOOD[1]	110	ATTN0[2]
15	PRST	47	DATA0/ADD5	79	VCC5V	111	ATTN1[2]
16	VCC5V	48	A4/ADD4	80	PRSNT1[1]	112	M66EN[2]
17	PCLK	49	VCC5V	81	PRSNT2[1]	113	DETECT0[2]
18	GND	50	A3/ADD3	82	SLOTTRST[1]	114	VCC5V
19	IDLEREQ	51	A2/ADD2	83	REQ64ON[1]	115	DETECT1[2]
20	IDLEGNT	52	A1/ADD1	84	GND	116	PWRON/OFF[3]
21	FRAME	53	A0/ADD0	85	REQ64ON[1]	117	PWRFAULT[3]
22	IRDY	54	GND	86	BUSON[1]	118	PWRGOOD[3]
23	VCCP	55	PWRON/OFF[0]	87	CLKON[1]	119	GND
24	INTR	56	PWRFAULT[0]	88	ATTN0[1]	120	PRSNT1[3]
25	INTR	57	PWRGOOD[0]	89	ATTN1[1]	121	PRSNT2[3]
26	SYSM66EN	58	PRSNT1[0]	90	VCC	122	SLOTTRST[3]
27	GND	59	VCC	91	M66EN[1]	123	REQ64ON[3]
28	SMODE	60	PRSNT2[0]	92	DETECT0[1]	124	GND
29	VCC5V	61	SLOTTRST[0]	93	DETECT1[1]	125	REQ64ON[3]
30	RD/SDA	62	REQ64ON[0]	94	RSVD	126	BUSON[3]
31	WR/SCL	63	REQ64ON[0]	95	RSVD	127	CLKON[3]
32	NC	64	NC	96	NC	128	NC

HPC3130A PCI HOT PLUG CONTROLLER

SCPS055 – NOVEMBER 1999

signal names by terminal name

Table 5. Signals Sorted Alphabetically by Terminal Name (144-Terminal Package)

TERMINAL NAME	NO.	TERMINAL NAME	NO.	TERMINAL NAME	NO.	TERMINAL NAME	NO.
A0/ADD0	59	$\overline{\text{DETECT1}}[2]$	129	NC	78	$\overline{\text{REQ64ON}}[3]$	137
A1/ADD1	58	$\overline{\text{DETECT1}}[3]$	8	NC	103	$\overline{\text{REQ64ON}}[0]$	72
A2/ADD2	57	$\overline{\text{FRAME}}$	23	NC	105	$\overline{\text{REQ64ON}}[1]$	95
A3/ADD3	56	GND	14	NC	107	$\overline{\text{REQ64ON}}[2]$	120
A4/ADD4	54	GND	20	NC	110	$\overline{\text{REQ64ON}}[3]$	140
ATTN0[0]	80	GND	29	NC	112	RSVD	37
ATTN0[1]	98	GND	50	NC	114	RSVD	39
ATTN0[2]	124	GND	60	NC	139	RSVD	41
ATTN0[3]	1	GND	83	NC	141	RSVD	73
ATTN1[0]	81	GND	94	NC	143	RSVD	75
ATTN1[1]	99	GND	122	PCLK	19	RSVD	106
ATTN1[2]	125	GND	133	$\overline{\text{PRSNT1}}[0]$	64	RSVD	108
ATTN1[3]	3	GND	138	$\overline{\text{PRSNT1}}[1]$	90	$\overline{\text{SGNT}}$	16
$\overline{\text{BUSON}}[0]$	77	$\overline{\text{IDLEGNT}}$	22	$\overline{\text{PRSNT1}}[2]$	115	$\overline{\text{SLOTREQ64}}[0]$	13
$\overline{\text{BUSON}}[1]$	96	$\overline{\text{IDLEREQ}}$	21	$\overline{\text{PRSNT1}}[3]$	134	$\overline{\text{SLOTREQ64}}[1]$	12
$\overline{\text{BUSON}}[2]$	121	INTR	27	$\overline{\text{PRSNT2}}[0]$	66	$\overline{\text{SLOTREQ64}}[2]$	11
$\overline{\text{BUSON}}[3]$	142	$\overline{\text{INTR}}$	26	$\overline{\text{PRSNT2}}[1]$	91	$\overline{\text{SLOTREQ64}}[3]$	10
$\overline{\text{CLKON}}[0]$	79	$\overline{\text{IRDY}}$	24	$\overline{\text{PRSNT2}}[2]$	117	$\overline{\text{SLOTTRST}}[0]$	68
$\overline{\text{CLKON}}[1]$	97	M66EN[0]	82	$\overline{\text{PRSNT2}}[3]$	135	$\overline{\text{SLOTTRST}}[1]$	92
$\overline{\text{CLKON}}[2]$	123	M66EN[1]	101	$\overline{\text{PRST}}$	17	$\overline{\text{SLOTTRST}}[2]$	118
$\overline{\text{CLKON}}[3]$	144	M66EN[2]	126	$\overline{\text{PWRFAULT}}[0]$	62	$\overline{\text{SLOTTRST}}[3]$	136
$\overline{\text{CS}}$	43	M66EN[3]	5	$\overline{\text{PWRFAULT}}[1]$	87	SMODE	30
DATA0/ADD5	53	NC	2	$\overline{\text{PWRFAULT}}[2]$	111	$\overline{\text{SREQ}}$	15
DATA1/ADD6	52	NC	4	$\overline{\text{PWRFAULT}}[3]$	131	SYSM66EN	28
DATA2	51	NC	6	$\overline{\text{PWRGOOD}}[0]$	63	VCC	9
DATA3	49	NC	31	$\overline{\text{PWRGOOD}}[1]$	88	VCC	45
DATA4	48	NC	33	$\overline{\text{PWRGOOD}}[2]$	113	VCC	65
DATA5	47	NC	35	$\overline{\text{PWRGOOD}}[3]$	132	VCC	100
DATA6	46	NC	38	$\overline{\text{PWRON/OFF}}[0]$	61	VCC	116
DATA7	44	NC	40	$\overline{\text{PWRON/OFF}}[1]$	86	VCC5V	18
$\overline{\text{DETECT0}}[0]$	84	NC	42	$\overline{\text{PWRON/OFF}}[2]$	109	VCC5V	32
$\overline{\text{DETECT0}}[1]$	102	NC	67	$\overline{\text{PWRON/OFF}}[3]$	130	VCC5V	55
$\overline{\text{DETECT0}}[2]$	127	NC	69	$\overline{\text{RD}}/\text{SDA}$	34	VCC5V	89
$\overline{\text{DETECT0}}[3]$	7	NC	71	$\overline{\text{REQ64ON}}[0]$	70	VCC5V	128
$\overline{\text{DETECT1}}[0]$	85	NC	74	$\overline{\text{REQ64ON}}[1]$	93	VCCP	25
$\overline{\text{DETECT1}}[1]$	104	NC	76	$\overline{\text{REQ64ON}}[2]$	119	$\overline{\text{WR/SCL}}$	36



POST OFFICE BOX 655303 • DALLAS, TEXAS 75265

signal names by terminal number

Table 6. Signals Sorted Numerically by Terminal Number (144-Terminal Package)

NO.	TERMINAL NAME	NO.	TERMINAL NAME	NO.	TERMINAL NAME	NO.	TERMINAL NAME
1	ATTN0[3]	37	RSVD	73	RSVD	109	PWRON/OFF[2]
2	NC	38	NC	74	NC	110	NC
3	ATTN1[3]	39	RSVD	75	RSVD	111	PWRFAULT[2]
4	NC	40	NC	76	NC	112	NC
5	M66EN[3]	41	RSVD	77	BUSON[0]	113	PWRGOOD[2]
6	NC	42	NC	78	NC	114	NC
7	DETECT0[3]	43	CS	79	CLKON[0]	115	PRSNT1[2]
8	DETECT1[3]	44	DATA7	80	ATTN0[0]	116	VCC
9	VCC	45	VCC	81	ATTN1[0]	117	PRSNT2[2]
10	SLOTREQ64[3]	46	DATA6	82	M66EN[0]	118	SLOTTRST[2]
11	SLOTREQ64[2]	47	DATA5	83	GND	119	REQ64ON[2]
12	SLOTREQ64[1]	48	DATA4	84	DETECT0[0]	120	REQ64ON[2]
13	SLOTREQ64[0]	49	DATA3	85	DETECT1[0]	121	BUSON[2]
14	GND	50	GND	86	PWRON/OFF[1]	122	GND
15	SREQ	51	DATA2	87	PWRFAULT[1]	123	CLKON[2]
16	SGNT	52	DATA1/ADD6	88	PWRGOOD[1]	124	ATTN0[2]
17	PRST	53	DATA0/ADD5	89	VCC5V	125	ATTN1[2]
18	VCC5V	54	A4/ADD4	90	PRSNT1[1]	126	M66EN[2]
19	PCLK	55	VCC5V	91	PRSNT2[1]	127	DETECT0[2]
20	GND	56	A3/ADD3	92	SLOTTRST[1]	128	VCC5V
21	IDLEREQ	57	A2/ADD2	93	REQ64ON[1]	129	DETECT1[2]
22	IDLEGNT	58	A1/ADD1	94	GND	130	PWRON/OFF[3]
23	FRAME	59	A0/ADD0	95	REQ64ON[1]	131	PWRFAULT[3]
24	IRDY	60	GND	96	BUSON[1]	132	PWRGOOD[3]
25	VCCP	61	PWRON/OFF[0]	97	CLKON[1]	133	GND
26	INTR	62	PWRFAULT[0]	98	ATTN0[1]	134	PRSNT1[3]
27	INTR	63	PWRGOOD[0]	99	ATTN1[1]	135	PRSNT2[3]
28	SYM66EN	64	PRSNT1[0]	100	VCC	136	SLOTTRST[3]
29	GND	65	VCC	101	M66EN[1]	137	REQ64ON[3]
30	SMODE	66	PRSNT2[0]	102	DETECT0[1]	138	GND
31	NC	67	NC	103	NC	139	NC
32	VCC5V	68	SLOTTRST[0]	104	DETECT1[1]	140	REQ64ON[3]
33	NC	69	NC	105	NC	141	NC
34	RD/SDA	70	REQ64ON[0]	106	RSVD	142	BUSON[3]
35	NC	71	NC	107	NC	143	NC
36	WR/SCL	72	REQ64ON[0]	108	RSVD	144	CLKON[3]

HPC3130A

PCI HOT PLUG CONTROLLER

SCPS055 – NOVEMBER 1999

Terminal Functions

This section describes the HPC3130A terminal functions. The terminals are grouped in tables by function.

power supply terminal functions

TERMINAL				I/O	FUNCTION
NAME	NO. 120	NO. 128	NO. 144		
GND	11, 17, 26, 41, 51, 68, 79, 101, 112, 117	12, 18, 27, 44, 54, 73, 84, 108, 119, 124	14, 20, 29, 50, 60, 83, 94, 122, 133, 138	I	Device ground terminals
VCC	6, 36, 56, 85, 95	7, 39, 59, 90, 102	9, 45, 65, 100, 116	I	3.3-V power supply
VCC5V	15, 28, 46, 74, 107	16, 29, 49, 79, 114	18, 32, 55, 89, 128	I	5-V clamp-rail voltage supply
VCCP	22	23	25	I	Clamp rail voltage for PCI signaling (5V or 3.3V)

control bus interface

TERMINAL				I/O	FUNCTION
NAME	NO. 120	NO. 128	NO. 144		
A2/ADD2 A1/ADD1 A0/ADD0	48 49 50	51 52 53	57 58 59	I	Parallel bus address. These terminals are address inputs in generic parallel bus cycles and are only used when the SMODE is input low. These lower address terminals select one of the eight registers for read/write access. Serial bus address select. These terminals indicate the full serial bus address of the HPC3130A when the SMODE is input high.
A4/ADD4 A3/ADD3	45 47	48 50	54 56	I	Parallel bus address. These terminals are address inputs in generic parallel bus cycles, and are only used when SMODE is input low. These upper address terminals select one of four hot-plug slots supported by the HPC3130A. Serial bus address select. These terminals indicate the full serial bus address of the HPC3130A when the SMODE is input high.
$\overline{\text{CS}}$	34	37	43	I	Chip selection. This active low input selects the HPC3130A chip as addressed in the current generic parallel bus cycle. This chip input is only valid if the SMODE is input low. Multiple HPC3130A chips may exist in a system with external logic driving this signal.
DATA1/ADD6 DATA0/ADD5	43 44	46 47	52 53	I/O	Parallel bus data. This bus is the data bus in generic parallel bus cycles and is selected when the SMODE is input low. The data path is used during both read and write transactions to internal registers when the parallel control bus interface is implemented. Serial bus address selection. These terminals indicate the full serial bus address of the HPC3130A when the SMODE is input high.
DATA7 DATA6 DATA5 DATA4 DATA3 DATA2	35 37 38 39 40 42	38 40 41 42 43 45	44 46 47 48 49 51	I/O	Parallel bus data. This bus is the data bus in generic parallel bus cycles and is selected when the SMODE is input low. The data path is used during both read and write transactions to internal registers when the parallel control bus interface is implemented.
$\overline{\text{RD}}/\text{SDA}$	29	30	34	I/O	Read selection. This terminal indicates a register read cycle when the SMODE input is low and the $\overline{\text{CS}}$ terminal input is asserted. This is used to read an internal HPC3130A register. Serial bus data. This terminal signals the serial bus data when the SMODE input is high. It is used during internal register read and write transactions.
$\overline{\text{WR}}/\text{SCL}$	30	31	36	I	Write selection. This terminal indicates a register write cycle when the SMODE input is low and the $\overline{\text{CS}}$ terminal input is asserted. This input is used to write to an internal HPC3130A register. Serial bus clock. This terminal inputs serial bus clock in when the SMODE input is high. It is used during internal register read and write transactions.



Terminal Functions (Continued)

system interface

TERMINAL				I/O	FUNCTION
NAME	NO. 120	NO. 128	NO. 144		
$\overline{\text{FRAME}}$	20	21	23	I	Frame. This input and the $\overline{\text{IRDY}}$ input indicate that the PCI bus is idle. When the HPC3130A senses the PCI bus is idle after $\overline{\text{IDLEGNT}}$ is low, a hot-plug slot can be connected to the PCI bus. This input must be wired to a valid logic level if the bus idling procedure is not implemented.
$\overline{\text{IDLEGNT}}$	19	20	22	I	Idle grant. This input indicates when the PCI bus is idled by the HOST-PCI bridge after a request is made by $\overline{\text{IDLEREQ}}$. The protocol is identical to PCI request/grant. This input must be wired to a valid logic level if the bus idling procedure is not implemented.
$\overline{\text{IDLEREQ}}$	18	19	21	O	Idle request. This output is driven to request the HOST-PCI bridge to idle the PCI bus before connecting a hot-plug slot. The protocol is identical to PCI request/grant. A pullup resistor must be implemented on this terminal if the bus idling procedure is not implemented.
INTR	24	25	27	O	System interrupt. This output provides a system interrupt. The HPC3130A can be programmed to assert this interrupt under various conditions, which may be serviced by the hot-plug service. Furthermore, the event status/enable state is compliant with the <i>ACPI Specification</i> and, as a result, supports ACPI control methods for switching the HPC3130A.
$\overline{\text{INTR}}$	23	24	26	O	System interrupt. This open drain output provides a system interrupt. The HPC3130A can be programmed to assert this interrupt under various conditions, which may be serviced by the hot-plug. Furthermore, the event status/enable state is compliant with the <i>ACPI Specification</i> and, as a result, supports ACPI control methods for switching the HPC3130A.
$\overline{\text{IRDY}}$	21	22	24	I	Initiator ready. This and the $\overline{\text{FRAME}}$ input indicate that the PCI bus is idle. When the HPC3130A senses the PCI bus is idle after $\overline{\text{IDLEGNT}}$ is low, a hot-plug slot may be connected to the PCI bus. This input must be wired to a valid logic level if the bus idling procedure is not implemented.
PCLK	16	17	19	I	PCI clock input. These terminals provide the PCI clock to the HPC3130A, which uses it only for activity indicator timing, $\overline{\text{IDLEREQ}}/\overline{\text{IDLEGNT}}$ protocol, and connection sequencing.
$\overline{\text{PRST}}$	14	15	17	I	PCI reset. This signal provides the PCI reset to the HPC3130A. After a PCI reset, the HPC3130A resides in a state where all slots are enabled, as in a non-hot-plug system. The HPC3130A passes PCI resets from the host to all hot-plug slots.
$\overline{\text{SGNT}}$	13	14	16	O	Secondary grant. This output provides a scheme to cascade a secondary HPC3130A device in order to provide more than four slots. The $\overline{\text{SGNT}}$ output from the primary HPC3130A is input to the $\overline{\text{IDLEGNT}}$ terminal for the secondary HPC3130A. After the secondary HPC3130A requests the primary HPC3130A to idle the bus, the primary HPC3130A arbitrates for the bus using $\overline{\text{IDLEREQ}}$. Once $\overline{\text{IDLEGNT}}$ is asserted, the primary HPC3130A asserts its $\overline{\text{SGNT}}$ output. This indicates to the secondary HPC3130A device that it can connect to the bus.
SMODE	27	28	30	I	Serial bus mode. When this input is asserted high, the internal HPC3130A registers are accessible through the serial bus interface; otherwise, they are accessed through the generic parallel bus interface. This input selects the control bus interface.
$\overline{\text{SREQ}}$	12	13	15	I	Secondary request. This input provides a scheme to cascade a second HPC3130A device in order to provide more than four slots. The $\overline{\text{IDLEREQ}}$ from the second HPC3130A device is input to the $\overline{\text{SREQ}}$ terminal of the primary HPC3130A. If the second HPC3130A device arbitrates for the bus by asserting its $\overline{\text{IDLEREQ}}$ output, this scheme causes the primary HPC3130A to assert its $\overline{\text{IDLEREQ}}$. If cascading is not used, this input is pulled high.
SYSM66EN	25	26	28	I/O	PCI bus frequency indicator. This signal indicates the PCI clock frequency requirements of the hot-plug slots, and must be tied to the system PCI bus M66EN signal. The output from this terminal only changes state after a PCI reset and is only required in a 66-MHz system.

HPC3130A PCI HOT PLUG CONTROLLER

SCPS055 – NOVEMBER 1999

Terminal Functions (Continued)

slot control and status functions

TERMINAL				I/O	FUNCTION
NAME	NO. 120	NO. 128	NO. 144		
ATTN0[3]	1	2	1	O	Attention indicators. These two outputs are provided per slot as attention indicators and can be independently programmed to drive high, low, fast blink, and slow blink. The timer is based on the PCI clock frequency and the state of SYSM66EN.
ATTN0[2]	103	110	124		
ATTN0[1]	83	88	98		
ATTN0[0]	65	70	80		
ATTN1[3]	2	3	3		
ATTN1[2]	104	111	125		
ATTN1[1]	84	89	99		
ATTN1[0]	66	71	81		
BUSON[3]	119	126	142	O	CBT switch control for PCI bus. This output controls the CBT switch that connects the hot-plug slot to the system PCI bus. This output is only driven by the HPC3130A under programmed control.
BUSON[2]	100	107	121		
BUSON[1]	81	86	96		
BUSON[0]	63	68	77		
CLKON[3]	120	127	144	O	PCI clock connection control. This output is used to control the CBT switch or clock driver that connects the hot-plug slot to the system PCI clock. This output is only driven by the HPC3130A under programmed control.
CLKON[2]	102	109	123		
CLKON[1]	82	87	97		
CLKON[0]	64	69	79		
DETECT0[3]	4	5	7	I	Card detection signals. These two card detect input signals, <u>DETECT0</u> and <u>DETECT1</u> , are provided as additional card detection signals to the <u>PRSNT1</u> and <u>PRSNT2</u> . Since only one present input must be tied to ground to indicate a card is present per the <i>PCI Specification</i> , these optional inputs are provided for designers of a more mechanically robust system. If the protection enable bit is set to 1 in the <u>general configuration register</u> , the HPC3130A does not power a hot-plug slot unless <u>DETECT0</u> and <u>DETECT1</u> are input low. A design not implementing additional card detection must tie these signals to ground. When this feature is utilized, the HPC3130A guarantees that power can not be applied to an empty slot or a slot with a partially inserted card.
DETECT0[2]	106	113	127		
DETECT0[1]	87	92	102		
DETECT0[0]	69	74	84		
DETECT1[3]	5	6	8		
DETECT1[2]	108	115	129		
DETECT1[1]	88	93	104		
DETECT1[0]	70	75	85		
M66EN[3]	3	4	5	I	PCI bus frequency indicator. This signal indicates the PCI clock frequency requirements of the hot-plug slots and is only required in a 66-MHz system (two slot maximum electrical loading limits). The two slot interfaces that provide the M66EN terminals are sensed at PCI reset and are driven afterwards.
M66EN[2]	105	112	126		
M66EN[1]	86	91	101		
M66EN[0]	67	72	82		
PRSNT1[3]	113	120	134	I	Present signals. These inputs are provided by hot-plug slots to indicate that an add-in card is physically present in the slot and to power requirements to the system. Only one of these signals must be tied to ground to indicate a card is present in an expansion slot. A set of <u>PRSNT1</u> and <u>PRSNT2</u> inputs are provided for each hot-plug slot.
PRSNT1[2]	94	101	115		
PRSNT1[1]	75	80	90		
PRSNT1[0]	55	58	64		
PRSNT2[3]	114	121	135		
PRSNT2[2]	96	103	117		
PRSNT2[1]	76	81	91		
PRSNT2[0]	57	60	66		
PWRFAULT[3]	110	117	131	I	Power fault. This input is provided per slot power switch to indicate if there is a power fault. The HPC3130A can be programmed to generate an interrupt through <u>INTR</u> when this input is asserted.
PWRFAULT[2]	92	99	111		
PWRFAULT[1]	72	77	87		
PWRFAULT[0]	53	56	62		
PWRGOOD[3]	111	118	132	I	Power good. This input is provided per slot power switch to indicate when power is successfully switched. The HPC3130A can be programmed to generate an interrupt through <u>INTR</u> when this input is asserted.
PWRGOOD[2]	93	100	113		
PWRGOOD[1]	73	78	88		
PWRGOOD[0]	54	57	63		



Terminal Functions (Continued)

slot control and status functions (continued)

TERMINAL				I/O	FUNCTION
NAME	NO. 120	NO. 128	NO. 144		
PWRON/OFF[3] PWRON/OFF[2] PWRON/OFF[1] PWRON/OFF[0]	109 91 71 52	116 98 76 55	130 109 86 61	○	Power ON/OFF. This output is provided per slot and is driven to the power switch to control the slot power state.
REQ64ON[3] REQ64ON[2] REQ64ON[1] REQ64ON[0]	116 98 78 59	123 105 83 62	137 119 93 70	○	CBT switch control for SLOTRREQ64. A CBT switch can be implemented to reduce trace loading of the additional REQ64 signal inherent to the HPC3130A controller. This output can be used to control the CBT switch. This output is only driven by the HPC3130A under programmed control.
REQ64ON[3] REQ64ON[2] REQ64ON[1] REQ64ON[0]	118 99 80 60	125 106 85 63	140 120 95 72	○	CBT switch control for SLOTRREQ64. A CBT switch can be implemented to reduce trace loading of the additional REQ64 signal inherent to the HPC3130A controller. This output can be used to control the CBT switch. This output is only driven by the HPC3130A under programmed control.
SLOTRREQ64[3] SLOTRREQ64[2] SLOTRREQ64[1] SLOTRREQ64[0]	7 8 9 10	8 9 10 11	10 11 12 13	○	Slot request 64. This output is driven in conjunction with SLOTRST to the hot-plug slot to indicate to option cards whether or not they are plugged into a 64-bit slot. If a 64-bit device is plugged into a 32-bit slot, then it must ensure that its high-word path inputs do not oscillate and that there is not a significant power drain through the input buffer. This output is only driven by the HPC3130A under programmed control.
SLOTRST[3] SLOTRST[2] SLOTRST[1] SLOTRST[0]	115 97 77 58	122 104 82 61	136 118 92 68	○	Slot PCI reset. This output is driven to the hot-plug slot to reset it after power up. When a card is inserted into a hot-plug slot it must be reset independent of the other PCI devices on the bus. This output is only driven by the HPC3130A under programmed control.

HPC3130A applications

This section discusses the various features of the HPC3130A in detail, and presents design considerations including a general connection sequencing guideline.

system implementation

Figure 1 illustrates the HPC3130A implementation. The PCI bus signals are switched to the hot-plug PCI slot by the BUSON output, which controls a CBT switch. The PCI clock, PCI reset, M66EN, and REQ64 must not be routed through the CBT switch. The HPC3130A drives the slot PCI reset and SLOTRREQ64, which can be controlled by internal HPC3130A registers. The SLOTRREQ64 requires special consideration during reset, as described. The PCI clock to the slot is driven by a clock driver, which is enabled by the HPC3130A CLKON output.

The HPC3130A also provides other features such as mechanical detection circuits, attention indicators, and interrupt signaling. The mechanical detection circuitry using the DETECT[1,0] inputs is displayed as a dotted line and is an optional feature. Two attention indicator outputs, ATTN[1,0], are provided: one indicator to draw the attention of the user to a particular slot for insertion/removal, and one optional indicator that can be used to indicate fault conditions. Additional features, such as 66-MHz capability and automatic sequencing, are discussed in the following sections.

HPC3130A PCI HOT PLUG CONTROLLER

SCPS055 – NOVEMBER 1999

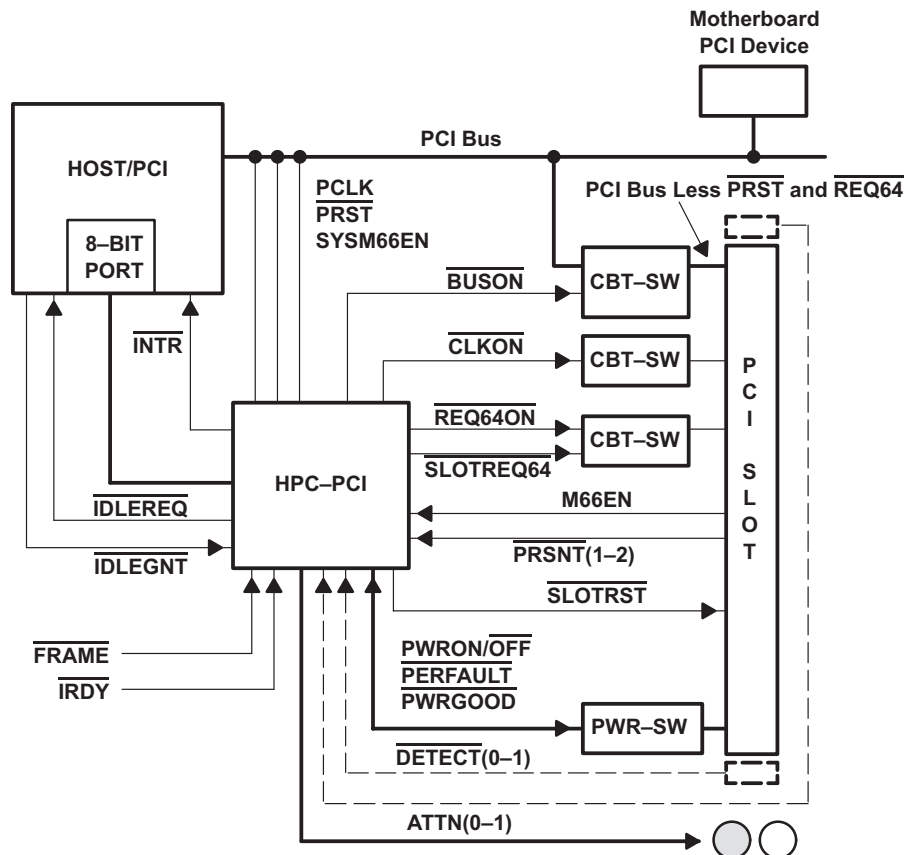

Figure 1. HPC3130A Implementation

The HPC3130A internal registers can be accessed through either a two-wire serial interface or an 8-bit generic parallel bus (ISA-like). The above figure illustrates the 8-bit port configuration. Not shown in the diagram is the SMODE chip input that must be wired low to indicate parallel bus interface mode. Also not shown in the diagram is the external chip-select logic required to select the HPC3130A in ISA bus cycles.

serial interface

The internal registers can be accessed either through a two-wire serial interface or through an 8-bit generic parallel interface. The SMODE input selects one of these modes.

The HPC3130A implements a two-pin serial slave interface with one clock signal (SCL) and one data signal (SDA). This serial interface can operate with a serial clock frequency up to 400 kHz. Both SCL and SDA require pullup resistors for the serial slave interface to function properly.

All data transfers are initiated by the serial bus master. The beginning of a data transfer is indicated by a START condition (S) when the SDA line transitions to a low state while SCL is in a high state as illustrated in Figure 2. The end of a requested data transfer is indicated by a STOP condition (P), which is the low-to-high transition of SDA while SCL is in the high state. Data on SDA must remain stable during the high state of the SCL signal. Changes on the SDA signal during the high state of SCL will be interpreted as control signals, that is, a START or STOP condition.

The SCL is an input into the HPC3130A and SDA is bidirectional.

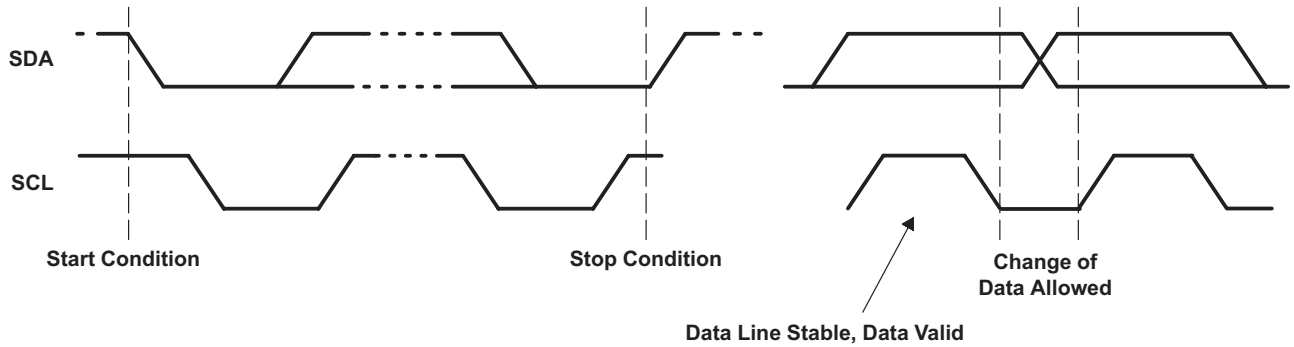

Figure 2. Serial Bus Start/Stop Conditions and Bit Transfers

Data is transferred on the bus in 8-bit bytes. The number of bytes that can be transmitted during a data transfer is unlimited; however, each byte must be completed with an acknowledge bit. An acknowledge (ACK) is indicated by the receiver pulling down the SDA signal so that it remains low during the high state of the SCL signal as shown in Figure 3.

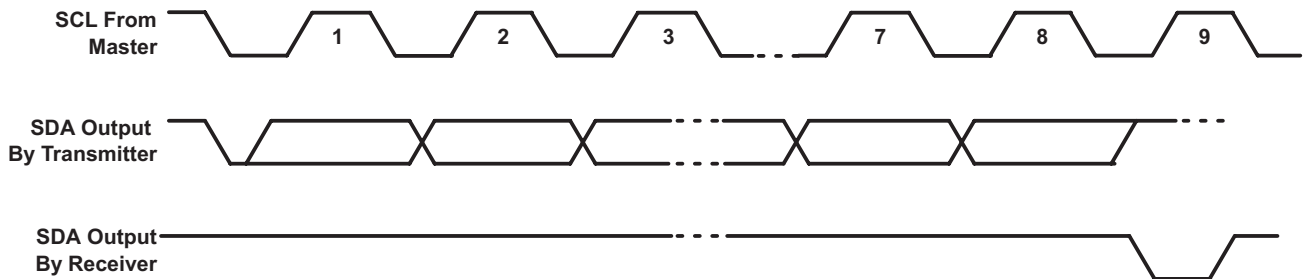

Figure 3. Serial Bus Protocol – Acknowledge

The HPC3130A serial bus slave interface protocol for write transactions is illustrated in Figure 4. The $\overline{R/\overline{W}}$ command bit is set to zero to indicate a write transaction. For a write operation, the HPC3130A requires a word address field after the slave address. This address field is comprised of eight bits. Upon receipt of the word address, the HPC3130A responds with an acknowledge, and waits for the next eight bits of data, again responding with an acknowledge. After all the data bytes are transferred, the master then terminates the transfer by generating a STOP condition. The device automatically increments the address for subsequent data words. After the receipt of each word, the low order address bits are internally incremented by one.

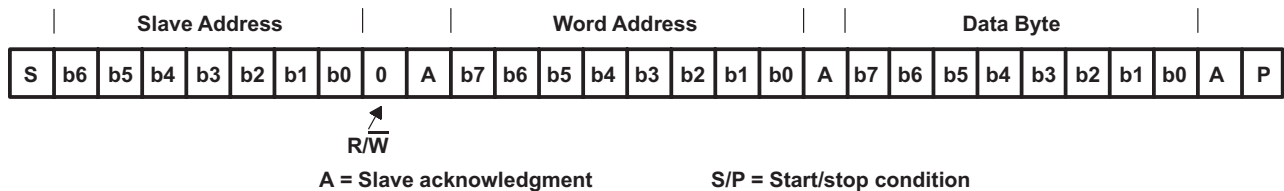

Figure 4. Serial Bus Protocol – Byte Write

A byte read operation is illustrated in Figure 5. The read protocol is very similar to the write protocol, except the $\overline{R/\overline{W}}$ command bit must be set to one to indicate a read data transfer. First the master issues a write command that includes the START condition and the slave address field (with the $\overline{R/\overline{W}}$ bit set to write), followed by the address of the word it is to read. This procedure sets the internal address counter of the HPC3130A to the desired address. After the word address acknowledgment is received by the master, the master immediately reissues a START condition followed by another slave address field with the $\overline{R/\overline{W}}$ bit set to read. The HPC3130A responds with an acknowledgment and transmits the eight data bits stored in the addressed location. If the

HPC3130A PCI HOT PLUG CONTROLLER

SCPS055 – NOVEMBER 1999

master responds with an acknowledge signal, indicating that it requires additional data, the HPC3130A continues to output data for each received acknowledge signal. The master terminates the sequential read operation by not responding with an acknowledge signal, and issues a STOP condition.

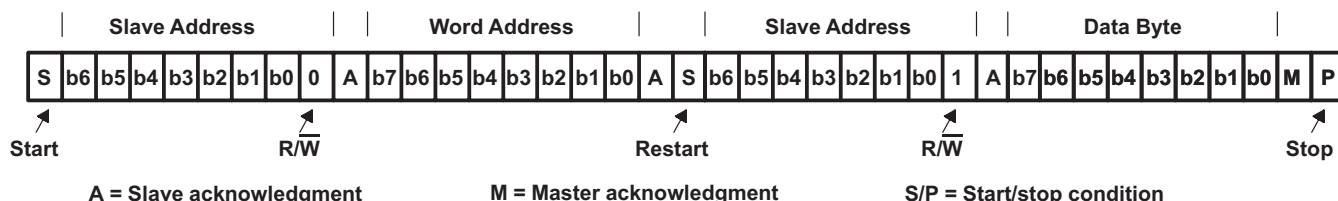

Figure 5. Serial Bus Protocol – Byte Read

parallel interface

The HPC3130A also implements an 8-bit parallel interface mode. When this mode is selected, the HPC3130A internal register addressed by the A[4:0] inputs can be accessed for a read/write transaction using the CS, RD, WR strobes. The following signals have pullups on the mother board: IO16, M16, NOWS, CHRDY, MEMR, MEMW, IOR, IOW, SD[15:0] to implement default states. Figure 6 shows write access using the default 8-bit standard ISA bus cycle with four wait states. A read cycle is similar.

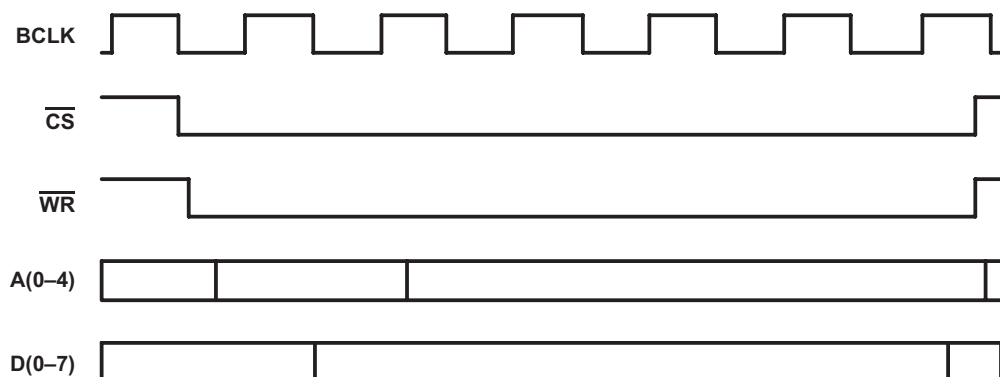

Figure 6. Parallel Bus Write Cycle

connection sequencing

Before an add-in card is hot plugged and made available to the slot, the various pins in the HPC3130A have to be controlled in a specific sequence. The HPC3130A provides the software interface to sequence the power to the slot, clocks, and signals to the add-in cards that are being live inserted. The switch-timing block is used to control the exact timing when the CBT switches are enabled.

The initial software sequencing is done by setting individual bits in the hot plug control register in the following sequence. First, the SLTPWR_CTL bit is set high to drive the PWRON/OFF signal high. After the power to the slot is applied, the SLOTRST_O bit is set low to drive the SLOTRST output. Next the CLKON_O bit is set low to enable the PCI clock to the slot. Also, the REQ64_O bit is set to a value of 0 and the SLOTREQ64 bit is set to indicate to the add-in card whether it is inserted into a 64-bit or 32-bit slot. SLOTREQ64 is set low for a 64-bit slot and is set high for a 32-bit slot.

After initial software sequencing of the above signals is complete, the next step is to enable the CBT switches. This can be done either by using the software to manually set the BUS_CTL bit or using the HPC3130A via the automatic connection sequence mode located in the general configuration register.

connection sequencing (continued)

If automatic sequencing mode 1 is selected, then the BUS_CTL bit controls the sequencing by using idling protocol. When this bit is set to zero, the switch-timing block will arbitrate for the PCI bus by asserting $\overline{\text{IDLEREQ}}$. Subsequently, $\overline{\text{IDLEGNT}}$ is asserted and the HPC3130A waits for bus idle condition. When $\overline{\text{FRAME}}$ and $\overline{\text{IRDY}}$ are deasserted, the CBT switches are enabled. Following this, the $\overline{\text{SLOTRST}}$, $\overline{\text{SLOTREQ64}}$ and $\overline{\text{REQ64ON}}$ are deasserted. Figure 7 depicts the sequencing of events when automatic sequencing mode 1 is enabled.

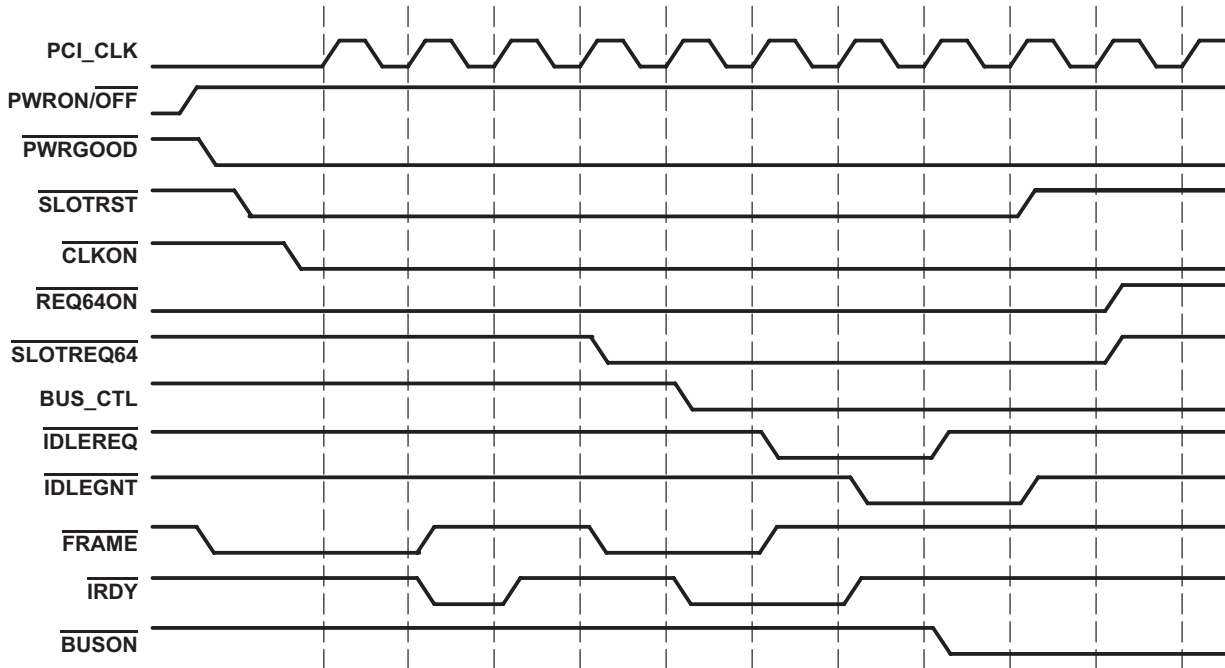

Figure 7. Automatic Connection Sequencing Mode 1

If automatic sequencing mode 2 is selected, then the BUS_CTL bit controls the sequencing by using idling protocol. When this bit is set to zero, the switch timing block arbitrates for the PCI bus by asserting $\overline{\text{IDLEREQ}}$. Subsequently, $\overline{\text{IDLEGNT}}$ is asserted and the HPC3130A waits for the bus idle condition. When $\overline{\text{FRAME}}$ and $\overline{\text{IRDY}}$ are deasserted, the $\overline{\text{SLOTRST}}$ is deasserted. Following this, the $\overline{\text{SLOTREQ64}}$ and $\overline{\text{REQ64ON}}$ are deasserted and the CBT switches are enabled. Figure 8 depicts the sequencing of events when automatic sequencing mode 2 is enabled.

HPC3130A PCI HOT PLUG CONTROLLER

SCPS055 – NOVEMBER 1999

connection sequencing (continued)

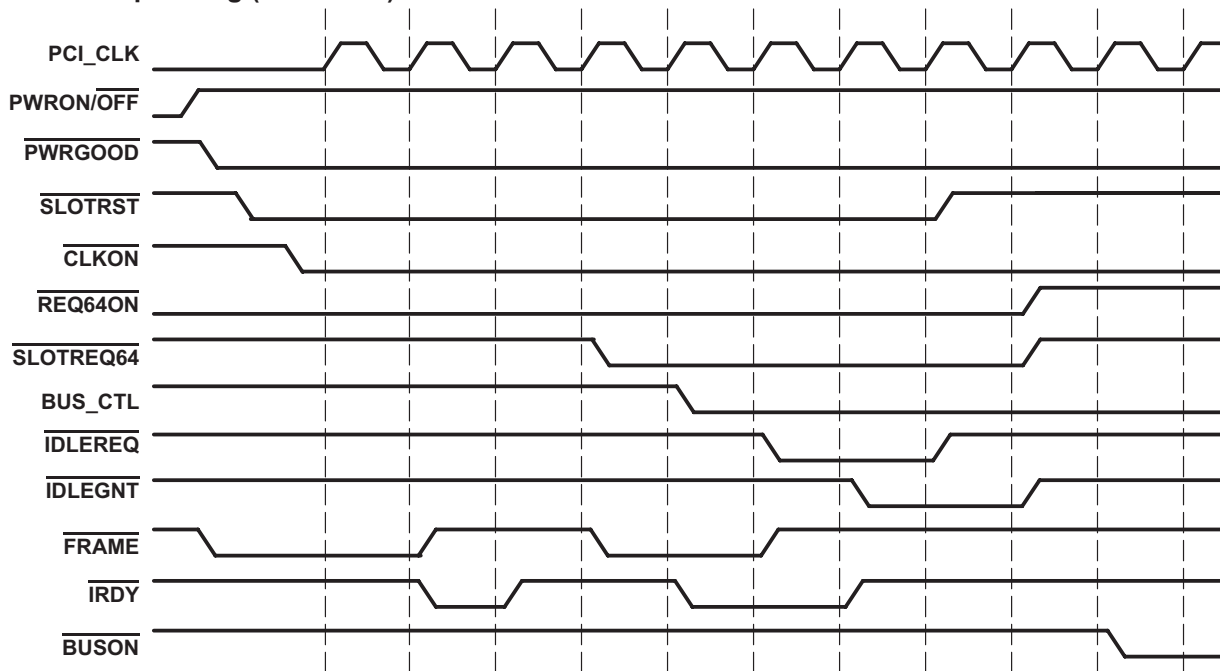

Figure 8. Automatic Connection Sequencing Mode 2

The protocol described above is identical to the PCI $\overline{\text{REQ}}/\overline{\text{GNT}}$ protocol used by PCI bus masters, which also must wait for bus idle through PCI $\overline{\text{FRAME}}$ and $\overline{\text{IRDY}}$ before initiating a PCI cycle. If the HPC3130A is connected to PCI $\overline{\text{FRAME}}$ and $\overline{\text{IRDY}}$, the HPC3130A arbitrates for the bus; although it does not drive the PCI bus or assert $\overline{\text{FRAME}}$ to start a cycle.

There are some issues with this implementation such as bus parking and additional loading on the PCI $\overline{\text{FRAME}}$ and $\overline{\text{IRDY}}$ signals, which need to be considered when designing a system. The system designer may have a level of confidence that PCI adapter cards can tolerate connection to a non-idle bus. In the scenario where the HPC3130A is not connected to the bus, then the $\overline{\text{FRAME}}$, $\overline{\text{IRDY}}$, and $\overline{\text{IDLEGNT}}$ must be wired to valid logic levels and the automatic sequencing will start without any relationship to the bus.

connection sequencing (continued)

$\overline{\text{IDLEREQ}}$, $\overline{\text{IDLEGNT}}$, $\overline{\text{FRAME}}$, and $\overline{\text{IRDY}}$ pins are not connected in manual mode. In contrast, during automatic connection, the HPC3130A requests the PCIBus to make sure it is idle before it sequences through the connection sequence.

In manual mode, software has to perform each part of the connection sequence. Figure 9 is an example of the manual connection sequence. There could be several other ways to implement this protocol.

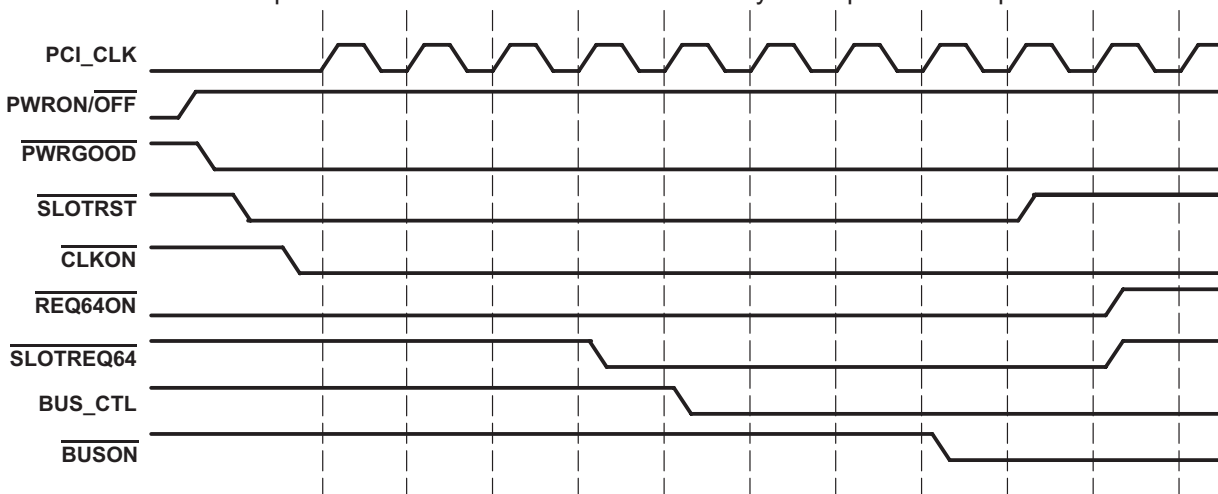

Figure 9. Manual Connection Sequencing

disconnecting sequence

The HPC3130A provides two mechanisms to isolate a PCI slot from the PCI bus so an add-in card can be removed. One of the mechanisms is called manual sequencing and is enabled by default. This mechanism allows the software to control the entire disconnect sequence. This means it is the software's responsibility to remove a powered slot from the PCI bus without any impact to the system.

The second mechanism is called autosequencing and can be enabled by programming either Auto-Sequence 1 or Auto-Sequence 2 in the general configuration register. Unlike the connection sequence, which has two different autoconnection sequencing modes, the autodisconnect sequence has only one mode of operation. The steps in the autodisconnect sequence are as follows:

1. Software may assert $\overline{\text{SLOTRST}}$ to the appropriate slot by writing a 0 to the SLOTRST_O bit in the hot-plug control register. This is optional.
2. Next the software must set the BUS_CTL bit in the hot-plug control register to a 1.
3. Once the BUS_CTL bit is set to a 1, the HPC3130A asserts $\overline{\text{IDLEREQ}}$.
4. Once $\overline{\text{IDLEGNT}}$ is asserted and $\overline{\text{FRAME}}$ and $\overline{\text{IRDY}}$ are deasserted, the HPC3130A deasserts $\overline{\text{BUSON}}$ and $\overline{\text{CLKON}}$ and asserts $\overline{\text{REQ64ON}}$ to isolate the slot from the PCI bus.
5. The HPC3130A then drives $\overline{\text{PWRON/OFF}}$ low to power off the slot.

HPC3130A PCI HOT PLUG CONTROLLER

SCPS055 – NOVEMBER 1999

disconnecting sequence (continued)

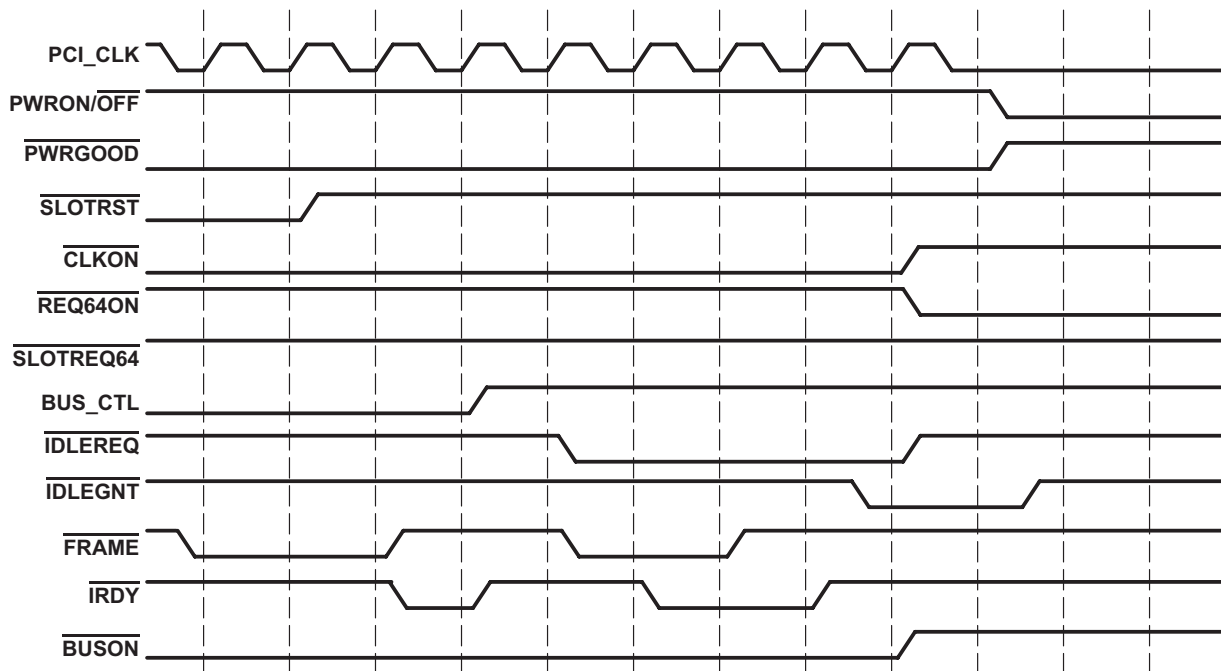

Figure 10. Automatic Disconnect Sequencing Mode

In manual disconnect mode, software has to perform each part of the disconnection sequence. Figure 11 is an example of the manual disconnection sequence. There could be several other ways to implement this protocol. During manual disconnection, the PCI bus may or may not idle; it will depend on the software implementation of the system.

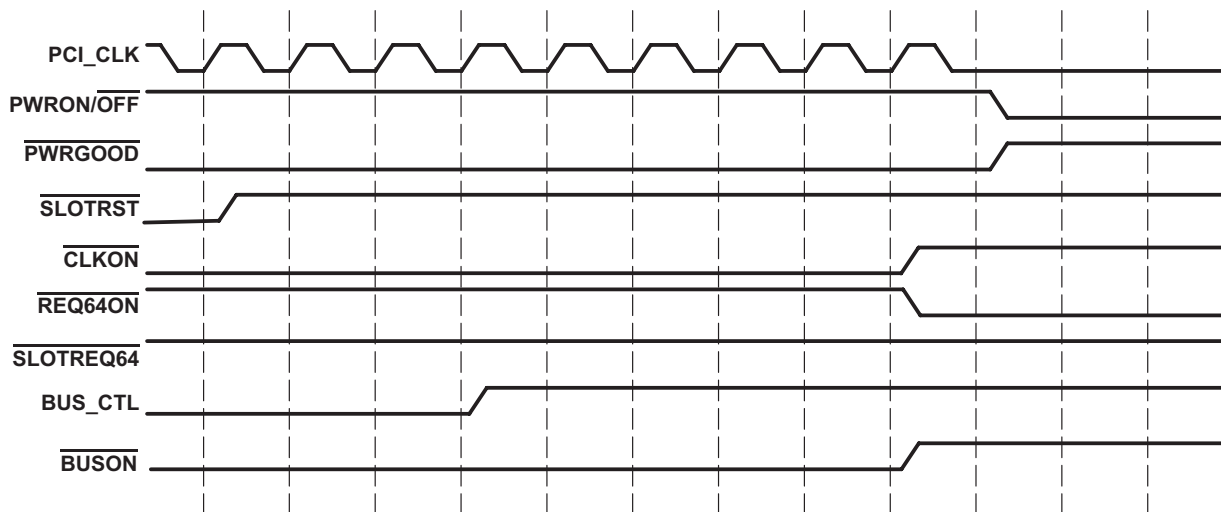

Figure 11. Manual Disconnect Sequencing Mode

64-bit implementation

When inserted into a slot, a 64-bit PCI card tests whether that slot is 64-bit or 32-bit. If $\overline{\text{REQ64}}$ is low when $\overline{\text{PCI_RST}}$ is deasserted, that signals the card that the slot is 64-bit; otherwise, the slot is 32-bit. The HPC3130A provides a mechanism to notify the PCI card it is connected to a 64-bit PCI slot. The mechanism uses $\overline{\text{REQ64ON}}$ and $\overline{\text{REQ64}}$ as CBT switch enables and $\overline{\text{SLOTREQ64}}$ as the slot specific $\overline{\text{REQ64}}$ signal. As depicted in figures 12 and 13, $\overline{\text{REQ64ON}}$ enables the CBT switch that routes $\overline{\text{SLOTREQ64}}$ to the slot, and $\overline{\text{REQ64ON}}$ enables the CBT switch that routes $\overline{\text{SYSTEMREQ64}}$ to the slot. $\overline{\text{SYSTEMREQ64}}$ will always be routed to the slot except when the slot is disconnected from the bus or during a connection sequence. It is very important during a connection sequence that the software clears bit 3 in the *hot plug control register* to drive $\overline{\text{SLOTREQ64}}$ low. The HPC3130A will deassert $\overline{\text{SLOTREQ64}}$ during the automatic connection sequence.

In a 32-bit PCI bus implementation, the $\overline{\text{SLOTREQ64}}$, $\overline{\text{REQ64ON}}$, and $\overline{\text{REQ64}}$ outputs are not connected.

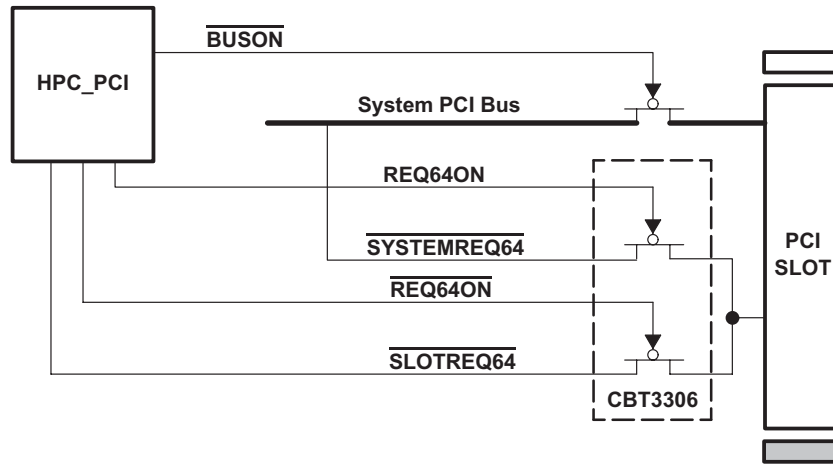

Figure 12. $\overline{\text{SLOTREQ64}}$ Implementation Using CBT3306

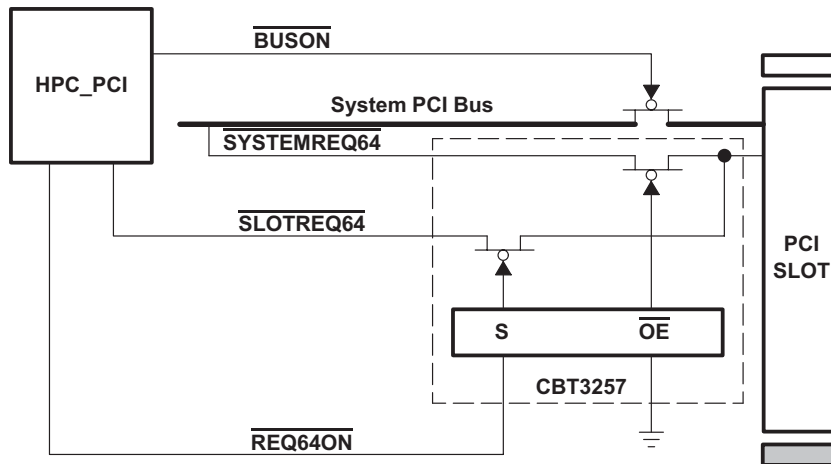

Figure 13. $\overline{\text{SLOTREQ64}}$ Implementation Using CBT3257

HPC3130A PCI HOT PLUG CONTROLLER

SCPS055 – NOVEMBER 1999

66-MHz PCI support

The HPC3130A supports up to two slots in a 66-MHz system: slot 0 and slot 1. These hot-plug slot interfaces include the M66EN signal and the SYSM66EN signal communicates hot-plug slot capability to the system. Figure 14 illustrates the 66-MHz support function in the HPC3130A.

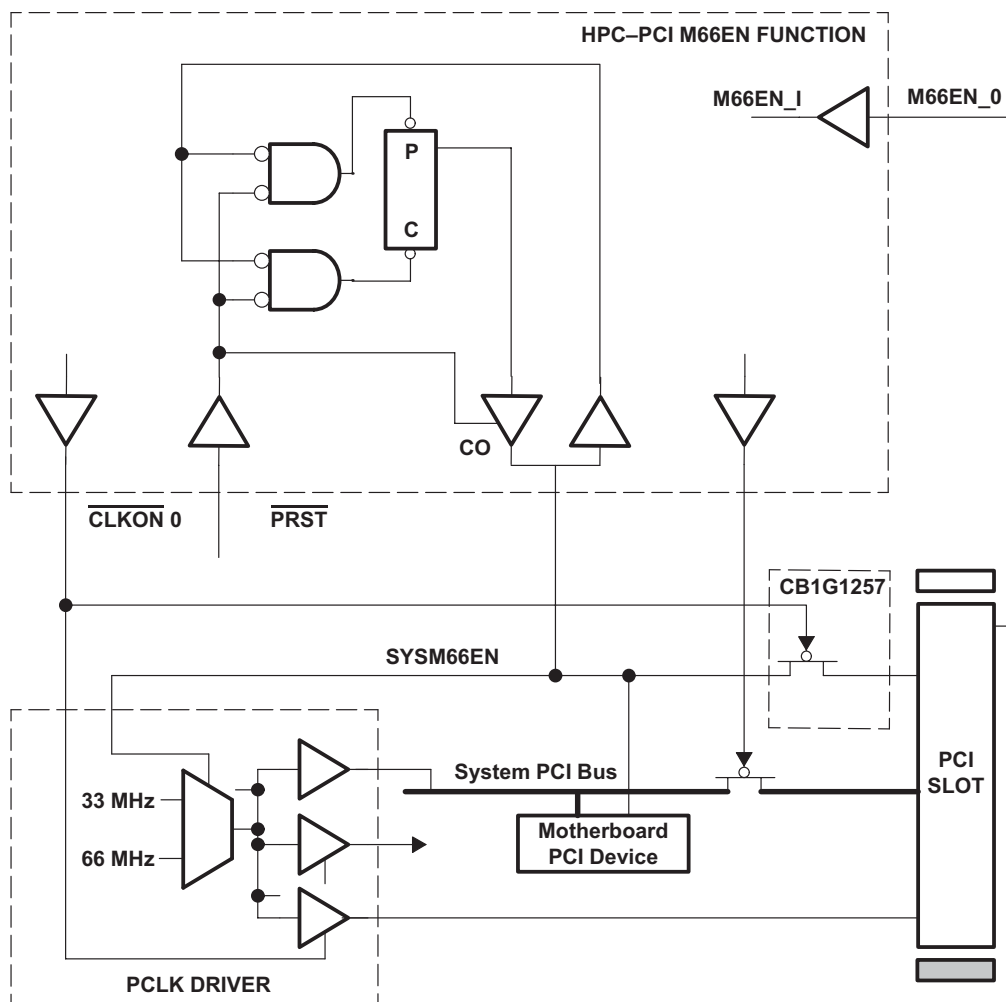

Figure 14. HPC3130A 66-MHz System Support

When the $\overline{\text{PCIRST}}$ signal is deasserted, the SYSM66EN signal is latched and selects the system frequency.

Before an adapter card can be inserted, the slot is prepared for insertion by deasserting $\overline{\text{BUSON}}$, deasserting $\overline{\text{CLKON}}$, and powering down the slot. When an adapter card is inserted into either hot-plug slot 0 or slot 1, $\overline{\text{PWRON/OFF}}$ is high, and power is applied, the value M66EN from the card can be read through internal registers. If the bus is operating at 66-MHz and a 33-MHz adapter card is inserted, then the software ensures that the card is never connected to the bus. If the bus is operating at 33 MHz and a 66-MHz adapter card is inserted, then the latched SYSM66EN state can be driven to the slot by enabling the CBT switch using $\overline{\text{CLKON}}$.

SYSM66EN and $\overline{\text{CLKON}}$ input to a clock driver circuit to control the PCI clock frequency. The 66-MHz support designed into the HPC3130A allows option cards to indicate PCI clock frequency capabilities upon PCI reset; however, does not allow an inserted hot-plug card to alter the clock frequency of an operating PCI bus.

configuration and control registers

The HPC3130A register set is accessible through either a generic parallel bus interface or a two-wire serial interface. Eight bytes of register space are provided per slot. Since the HPC3130A supports four slots, a total of 32 bytes of registers is implemented. Register and bit descriptions are provided in the following sections and indicate the bits that are common to all slots. The bit default values are given, which represent the state of the HPC3130A after a PCI reset event. After a PCI reset, the HPC3130A drives outputs to a state such that the slots appear as if they were not a hot-plug platform.

The register map that follows provides the register overview. Byte addressing is required when accessing the internal registers. Read transactions from reserved registers return zeros.

Table 7. Register Map

SLOT	REGISTER NAME	ADDRESS	SLOT	REGISTER NAME	ADDRESS
Slot 0	General configuration register	0x00	Slot 2	General configuration register	0x10
Slot 0	Hot-plug slot status register	0x01	Slot 2	Hot-plug slot status register	0x11
Slot 0	Hot-plug slot control register	0x02	Slot 2	Hot-plug slot control register	0x12
Slot 0	Attention indicator control	0x03	Slot 2	Attention indicator control	0x13
Slot 0	Reserved	0x04	Slot 2	Reserved	0x14
Slot 0	Reserved	0x05	Slot 2	Reserved	0x15
Slot 0	Interrupt event status register	0x06	Slot 2	Interrupt event status register	0x16
Slot 0	Interrupt event enable register	0x07	Slot 2	Interrupt event enable register	0x17
Slot 1	General configuration register	0x08	Slot 3	General configuration register	0x18
Slot 1	Hot-plug slot status register	0x09	Slot 3	Hot-plug slot status register	0x19
Slot 1	Hot-plug slot control register	0x0A	Slot 3	Hot-plug slot control register	0x1A
Slot 1	Attention indicator control	0x0B	Slot 3	Attention indicator control	0x1B
Slot 1	Reserved	0x0C	Slot 3	Reserved	0x1C
Slot 1	Reserved	0x0D	Slot 3	Reserved	0x1D
Slot 1	Interrupt event status register	0x0E	Slot 3	Interrupt event status register	0x1E
Slot 1	Interrupt event enable register	0x0F	Slot 3	Interrupt event enable register	0x1F

HPC3130A PCI HOT PLUG CONTROLLER

SCPS055 – NOVEMBER 1999

configuration and control registers (continued)

general configuration register

Bit	7	6	5	4	3	2	1	0
Name	General configuration register							
Type	R	R	R	R	R/W	R/W	R	R/W
Default	0	0	1	1	0	0	X	0

Register: General configuration
 Type: Read-only, Read/Write
 Offset: 00h (slot 0), 08h (slot 1), 10h (slot 2), 18h (slot 3)
 Default: 0Xh
 Description: This register is for general configurations and indications. The automatic PCI bus connection sequencing is enabled through this register, and the register access mode is indicated. This register is shared among all four slots.

Table 8. General Configuration Register

BIT	TYPE	NAME	FUNCTION
7–4	R	RSVD	Reserved for revision ID. These bits return 0011b for this device.
3–2	R/W	SEQUENCING	Automatic PCI bus connection sequencing. These bits control the sequencing used to connect the hot-plug slot to the PCI bus. 00 = Manual sequencing through register accesses 01 = Auto–Sequence 1: Enable CBT switches before deasserting $\overline{\text{RST}}$ 10 = Auto–Sequence 2: Enable CBT switches after deasserting $\overline{\text{RST}}$ 11 = Reserved
1	R	SYSM66STAT	Status of SYSM66EN. This bit represents the latched value of SYSM66EN during a PCI reset. A value of 1 indicates the PCI bus is operating at a frequency greater than 33 MHz. A value of 0 indicates the PCI bus is operating at 33 MHz or less.
0	R/W	PROTECTEN	Protection enable. This bit enables a protection mechanism provided by the HPC3130A. When this bit is enabled and either of the $\overline{\text{DETECT}}[1:0]$ inputs are high, the HPC3130A drives the $\overline{\text{BUS_ON}}$ and $\overline{\text{CLKON}}$ outputs high. The HPC3130A also drives $\overline{\text{PWRON/OFF}}$ and $\overline{\text{REQ64ON}}$ outputs low.



configuration and control registers (continued)

hot-plug slot status register

Bit	7	6	5	4	3	2	1	0
Name	Hot-plug slot status register							
Type	R	R	R	R	R	R	R	R
Default	X	X	X	X	X	X	X	X

Register: Hot-plug slot status
 Type: Read-only
 Offset: 01h (slot 0), 09h (slot 1), 11h (slot 2), 19h (slot 3)
 Default: XXh
 Description: This register reports card detection, power status, and other chip input from the hot-plug slot interface. All bits in this register are read only, and the data read from each bit represents the logical value of the data input from the corresponding terminal.

Table 9. Hot-Plug Slot Status Register

BIT	TYPE	NAME	FUNCTION
7	R	BUSON	Bus on. This bit returns the logical value of the <u>BUSON</u> terminal output.
6	R	M66EN_I	M66EN input. This bit returns the logical value of the M66EN terminal input.
5	R	PWRGOOD_I	Power good input. This bit returns the logical value of the <u>PWRGOOD</u> terminal input.
4	R	PWRFAULT_I	Power fault input. This bit returns the logical value of the <u>PWRFAULT</u> terminal input.
3	R	DETECT1_I	Mech detect 1 input. This bit returns the logical value of the <u>DETECT1</u> terminal input.
2	R	DETECT0_I	Mech detect 0 input. This bit returns the logical value of the <u>DETECT0</u> terminal input.
1	R	PRSNT2_I	Card present 2 input. This bit returns the logical value of the <u>PRSNT2</u> terminal input.
0	R	PRSNT1_I	Card present 1 input. This bit returns the logical value of the <u>PRSNT1</u> terminal input.

HPC3130A

PCI HOT PLUG CONTROLLER

SCPS055 – NOVEMBER 1999

configuration and control registers (continued)

hot-plug slot control register

Bit	7	6	5	4	3	2	1	0
Name	Hot-plug slot control register							
Type	R	R	R/W	R/W	R/W	R/W	R/W	R/W
Default	0	0	1	0	1	1	0	1

Register: Hot-plug slot control
 Type: Read-only, Read/Write
 Offset: 02 (slot 0), 0Ah (slot 1), 12h (slot 2), 1Ah (slot 3)
 Default: 2Dh
 Description: This register applies power, resets, and provides general control of a hot-plug slot connection to the system PCI bus.

Table 10. Hot-Plug Slot Control Register

BIT	TYPE	NAME	FUNCTION
7	R	RSVD	Reserved. This bit returns 0 when read.
6	R	RSVD	Reserved. This bit returns 0 when read.
5	R/W	SLTPWR_CTL	Slot power $\overline{\text{On/Off}}$ control. The data written to this bit represents the logical value of the data to drive the $\overline{\text{PWRON/OFF}}$ output and is used to control the power state of a hot-plug slot. If the $\overline{\text{PROTECTEN}}$ bit in the general configuration register is set to 1, then a logic high can only be driven by the $\overline{\text{PWRON/OFF}}$ output if the $\overline{\text{DETECT}}[1:0]$ inputs are low.
4	R/W	BUS_CTL	PCI bus CBT-switch control. When manual sequencing is enabled, then the value written to this bit represents the logical value of the data driven to the $\overline{\text{BUSON}}$ output, and it is used to connect/disconnect a hot-plug slot to/from the PCI bus. If an auto sequencing mode is enabled in the general configuration register, then this bit functions as follows: 1 = By setting this bit, the hot-plug slot gets disconnected from the PCI bus. This is accomplished by asserting $\overline{\text{IDLEREQ}}$, then waiting for $\overline{\text{IDLEGNT}}$ assertion and deassertion of $\overline{\text{FRAME}}$ and $\overline{\text{IRDY}}$ before driving $\overline{\text{BUSON}}$ high, $\overline{\text{CLKON}}$ high, $\overline{\text{REQ64ON}}$ low, and $\overline{\text{PWRON/OFF}}$ low. 0 = By clearing this bit, the hot-plug slot gets connected to the PCI bus. This is accomplished by asserting $\overline{\text{IDLEREQ}}$, then waiting for $\overline{\text{IDLEGNT}}$ assertion and deassertion of $\overline{\text{FRAME}}$ and $\overline{\text{IRDY}}$ before driving $\overline{\text{BUSON}}$ low. Also verifies assertion of $\overline{\text{DETECT}}[1:0]$ if the protection enable bit is enabled in the general configuration register.
3	R/W	SLOTREQ64	Slot request 64-bit control. The data written to this bit represents the logical value of the data driven to the $\overline{\text{SLOTREQ64}}$ output and is used during reset of a slot after power is applied. This input indicates to an option card whether or not it is connected to a 64-bit slot.
2	R/W	REQ64_O	$\overline{\text{REQ64}}$ CBT switch control. The data written to this bit represents the logical value of the data driven to the $\overline{\text{REQ64ON}}$ output and is used to control the CBT switch that implements the $\overline{\text{REQ64}}$ PCI signal.
1	R/W	CLKON_O	$\overline{\text{CLKON}}$ CBT switch control. The data written to this bit represents the logical value of the data driven to the $\overline{\text{CLKON}}$ output and is used to control the clock driver to the hot-plug slot.
0	R/W	SLOTTRST_O	Slot reset control. The data written to this bit represents the logical value of the data driven to the $\overline{\text{SLOTTRST}}$ output and is used to reset a hot-plug slot after power is applied.



configuration and control registers (continued)

attention indicator control register

Bit	7	6	5	4	3	2	1	0
Name	Attention indicator control register							
Type	R	R	R	R	R/W	R/W	R/W	R/W
Default	0	0	0	0	0	0	0	0

Register: Attention indicator control
 Type: Read-only, Read/Write
 Offset: 03 (slot 0), 0Bh (slot 1), 13h (slot 2), 1Bh (slot 3)
 Default: 00h
 Description: This register controls the attention indicators. The timing for the indicators is based upon the PCI clock and the M66EN input.

Table 11. Attention Indicator Control Register

BIT	TYPE	NAME	FUNCTION
7	R	RSVD	Reserved. This bit returns 0 when read.
6	R	RSVD	Reserved. This bit returns 0 when read.
5	R	RSVD	Reserved. This bit returns 0 when read.
4	R	RSVD	Reserved. This bit returns 0 when read.
3–2	R/W	ATTN1_CTL	Attention indicator 1 control. These bits control the state of ATTN1 per slot and are programmed as follows: 00 = Drive low 01 = Slow blink – 1 cycle per second 10 = Fast blink – 2 cycles per second 11 = Drive high
1–0	R/W	ATTN0_CTL	Attention indicator 0 control. These bits control the state of ATTN0 per slot and are programmed as follows: 00 = Drive low 01 = Slow blink – 1 cycle per second 10 = Fast blink – 2 cycles per second 11 = Drive high

HPC3130A PCI HOT PLUG CONTROLLER

SCPS055 – NOVEMBER 1999

configuration and control registers (continued)

interrupt event status register

Bit	7	6	5	4	3	2	1	0
Name	Interrupt event status register							
Type	R	R/C	R/C	R/C	R/C	R/C	R/C	R/C
Default	0	0	0	0	0	0	0	0

Register: Interrupt event status
 Type: Read-only, Read/Clear
 Offset: 06h (slot 0), 0Eh (slot 1), 16h (slot 2), 1Eh (slot 3)
 Default: 00h
 Description: This register reads interrupt status, and clears the interrupt. All functional bits in this register are readable and cleared by a write back of 1. The HPC3130A can be programmed to generate an interrupt, signaled through the open-drain $\overline{\text{INTR}}$, after detecting various events. Each event is individually enabled through the interrupt event enable register.

Table 12. Interrupt Event Status Register

BIT	TYPE	NAME	FUNCTION
7	R	RSVD	Reserved. This bit returns 0 when read.
6	R/C	BUS_S	PCI Bus CBT switch status. This bit is set when the $\overline{\text{BUSON}}$ output changes state, and is cleared by a write back of 1. The BUS event is intended for use with the idling protocol.
5	R/C	PWRGOOD_S	Power good status. This bit is set when the $\overline{\text{PWRGOOD}}$ input changes state.
4	R/C	PWRFAULT_S	Power fault status. This bit is set when the $\overline{\text{PWRFAULT}}$ input is asserted.
3	R/C	DETECT1_S	Mechanical detect 1 status. This bit is set when the $\overline{\text{DETECT1}}$ input changes state.
2	R/C	DETECT0_S	Mechanical detect 0 status. This bit is set when the $\overline{\text{DETECT0}}$ input changes state.
1	R/C	PRSNT2_S	Card present 2 status. This bit is set when the $\overline{\text{PRSNT2}}$ input changes state.
0	R/C	PRSNT1_S	Card present 1 status. This bit is set when the $\overline{\text{PRSNT1}}$ input changes state.

configuration and control registers (continued)

interrupt event enable register

Bit	7	6	5	4	3	2	1	0
Name	Interrupt event enable register							
Type	R	R/W	R/W	R/W	R/W	R/W	R/W	R/W
Default	0	0	0	0	0	0	0	0

Register: Interrupt event enable
 Type: Read-only, Read/Write
 Offset: 07h (slot 0), 0Fh (slot 1), 17h (slot 2), 1Fh (slot 3)
 Default: 00h
 Description: This register is used to enable interrupts, signaled through the open-drain $\overline{\text{INTR}}$, after detecting various events. Event status is reported through the interrupt event status register.

Table 13. Interrupt Event Enable Register

BIT	TYPE	NAME	FUNCTION
7	R	RSVD	Reserved. This bit returns 0 when read.
6	R/W	BUS_E	PCI bus CBT switch event enable. When this bit is set, an $\overline{\text{INTR}}$ is signaled when the $\overline{\text{BUSON}}$ output changes state. The BUS event is intended for use with the idling protocol.
5	R/W	PWRGOOD_E	Power good event enable. When this bit is set, an $\overline{\text{INTR}}$ is signaled when the $\overline{\text{PWRGOOD}}$ input changes state.
4	R/W	PWRFAULT_E	Power fault event enable. When this bit is set, an $\overline{\text{INTR}}$ is signaled when $\overline{\text{PWRFAULT}}$ input is asserted.
3	R/W	DETECT1_E	Mechanical detect 1 event enable. Enables $\overline{\text{INTR}}$ events on $\overline{\text{DETECT1}}$ input state changes.
2	R/W	DETECT0_E	Mechanical detect 0 event enable. Enables $\overline{\text{INTR}}$ events on $\overline{\text{DETECT0}}$ input state changes.
1	R/W	PRSNT2_E	Card present 2 event enable. Enables $\overline{\text{INTR}}$ events on $\overline{\text{PRSNT2}}$ input state changes.
0	R/W	PRSNT1_E	Card present 1 event enable. Enables $\overline{\text{INTR}}$ events on $\overline{\text{PRSNT1}}$ input state changes.

HPC3130A

PCI HOT PLUG CONTROLLER

SCPS055 – NOVEMBER 1999

absolute maximum ratings over operating free-air temperature range†

Supply voltage range, V_{CC}	-0.5 V to 3.6 V
V_{CCP} and V_{CC5V}	-0.5 V to 5.5 V
Input voltage range, V_I :	
PCI	-0.5 V to $V_{CCP} + 0.5$ V
SLOT	-0.5 V to $V_{CC5V} + 0.5$ V
BUSON	-0.5 V to $V_{CC5V} + 0.5$ V
Parallel	-0.5 V to $V_{CC5V} + 0.5$ V
Parallel/serial	-0.5 V to $V_{CC5V} + 0.5$ V
Miscellaneous	-0.5 V to $V_{CC5V} + 0.5$ V
Output voltage range, V_O :	
PCI	-0.5 V to $V_{CCP} + 0.5$ V
SLOT	-0.5 V to $V_{CC5V} + 0.5$ V
BUSON	-0.5 V to $V_{CC5V} + 0.5$ V
Parallel	-0.5 V to $V_{CC5V} + 0.5$ V
Parallel/serial	-0.5 V to $V_{CC5V} + 0.5$ V
Miscellaneous	-0.5 V to $V_{CC5V} + 0.5$ V
Input clamp current, I_{IK} ($V_I < 0$ or $V_I > V_{CC}$) (see Note 1)	± 20 mA
Output clamp current, I_{OK} ($V_O < 0$ or $V_O > V_{CC}$) (see Note 2)	± 20 mA
Storage temperature range	-65°C to 150°C
Junction temperature, T_J	150°C

† Stresses beyond those listed under “absolute maximum ratings” may cause permanent damage to the device. These are stress ratings only, and functional operation of the device at these or any other conditions beyond those indicated under “recommended operating conditions” is not implied. Exposure to absolute-maximum-rated conditions for extended periods may affect device reliability.

- NOTES: 1. Applies to external input and bidirectional buffers. For 5-V tolerant use $V_I > V_{CC5V}$. For universal PCI, use $V_I > V_{CCP}$.
 2. Applies to external output and bidirectional buffers. For 5-V tolerant use $V_O > V_{CC5V}$. For universal PCI, use $V_O > V_{CCP}$.



recommended operating conditions

			MIN	NOM	MAX	UNIT
V_{CC}	Core voltage	Commercial	3	3.3	3.6	V
V_{CCP}	PCI I/O voltage	Commercial	3	5	5.5	V
V_{CC5V}	Slot I/O voltage	Commercial	3	5	5.5	V
V_{CC5V}	Parallel I/O voltage	Commercial	3	5	5.5	V
V_{CC5V}	Serial I/O voltage	Commercial	3	5	5.5	V
V_{CC5V}	Miscellaneous I/O voltage	Commercial	3	5	5.5	V
V_I	Input voltage	PCI	0		V_{CCP}	V
		Slot	0		V_{CC5V}	
		BUSON	0		V_{CC5V}	
		Parallel	0		V_{CC5V}	
		Parallel/Serial	0		V_{CC5V}	
		Miscellaneous	0		V_{CC5V}	
V_O	Output voltage†	PCI	0		V_{CC}	V
		Slot	0		V_{CC}	
		BUSON	0		V_{CC}	
		Parallel	0		V_{CC}	
		Parallel/Serial	0		V_{CC}	
		Miscellaneous	0		V_{CC}	
V_{IH}	High-level input voltage	PCI	2		V_{CCP}	V
		Slot	2		V_{CC5V}	
		BUSON	2		V_{CC5V}	
		Parallel	2		V_{CC5V}	
		Parallel/Serial	2		V_{CC5V}	
		Miscellaneous	2		V_{CC5V}	
V_{IL}	Low-level input voltage	PCI	0		0.8	V
		Slot	0		0.8	
		BUSON	0		0.8	
		Parallel	0		0.8	
		Parallel/Serial	0		0.8	
		Miscellaneous	0		0.8	
t_t	Input transition time (t_r and t_f) (10% to 90%)	PCI	0		6	ns
		Slot	0		6	
		BUSON	0		6	
		Parallel/Serial	0		6	
		Miscellaneous	0		6	
T_A	Operating ambient temperature range		0	25	70	°C
T_J	Virtual junction temperature‡		0	25	115	°C

† Applies to external output buffers.

‡ These junction temperatures reflect simulation conditions. Customer is responsible for verifying junction temperature.

HPC3130A

PCI HOT PLUG CONTROLLER

SCPS055 – NOVEMBER 1999

serial bus interface

			STANDARD MODE		FAST MODE		UNIT
			MIN	MAX	MIN	MAX	
V_{IL}	Low-level input voltage	Fixed: V_{CC5V} related:	-0.5 -0.5	1.5 $0.3 V_{CC5V}$	-0.5 -0.5	1.5 $0.3 V_{CC5V}$	V
V_{IH}	High-level input voltage	Fixed: V_{CC5V} related:	0 $0.7 V_{CC5V}$	$V_{CC5V \max} + 0.5$ $V_{CC5V \max} + 0.5$	3 $0.7 V_{CC5V}$	$V_{CC5V \max} + 0.5$ $V_{CC5V \max} + 0.5$	V

electrical characteristics over recommended operating conditions

PARAMETER	PINS	OPERATION	TEST CONDITIONS	MIN	MAX	UNIT
V_{OH}	PCI□	3.3 V	$I_{OH} = -0.5 \text{ mA}$	$0.9 V_{CC}$		V
		5 V	$I_{OH} = -2 \text{ mA}$	$V_{CC} - 0.6$		
	Slot§		$I_{OH} = -8 \text{ mA}$	$V_{CC} - 0.6$		
	BUSON¶		$I_{OH} = -8 \text{ mA}$	$V_{CC} - 0.6$		
	Parallel#		$I_{OH} = -4 \text{ mA}$	$V_{CC} - 0.6$		
	Parallel/Serial		$I_{OH} = -4 \text{ mA}$	$V_{CC} - 0.6$		
	Miscellaneous☆		$I_{OH} = -8 \text{ mA}$	$V_{CC} - 0.6$		
V_{OL}	PCI□	3.3 V	$I_{OL} = 1.5 \text{ mA}$		$0.1 V_{CC}$	V
		5 V	$I_{OL} = 6 \text{ mA}$		0.55	
	Slot§		$I_{OL} = 8 \text{ mA}$		0.5	
	BUSON¶		$I_{OL} = 8 \text{ mA}$		0.5	
	Parallel#		$I_{OL} = 4 \text{ mA}$		0.5	
	Parallel/Serial		$I_{OL} = 4 \text{ mA}$		0.5	
	Miscellaneous☆		$I_{OL} = 2 \text{ mA}$		0.5	
I_{IL}^\dagger	PCI□		$V_I = \text{GND}$		-20	μA
	Slot§		$V_I = \text{GND}$		-20	
	BUSON¶		$V_I = \text{GND}$		-20	
	Parallel#		$V_I = \text{GND}$		-20	
	Parallel/Serial		$V_I = \text{GND}$		-20	
	Miscellaneous☆		$V_I = \text{GND}$		-20	
I_{IH}^\dagger	PCI□		$V_I = V_{CC}$		20	μA
	Slot§		$V_I = V_{CC}$		20	
	BUSON¶		$V_I = V_{CC}$		20	
	Parallel#		$V_I = V_{CC}$		20	
	Parallel/Serial		$V_I = V_{CC}$		20	
	Miscellaneous☆		$V_I = V_{CC}$		20	
I_{OZ}	High-impedance-state output current		$V_I = V_{CC}$ or GND		± 20	μA

† Specifications apply only when pullup terminator is turned off.

‡ For I/O pins, the input leakage current includes the off state output current I_{OZ} .

□ PCI terminals: 120 PBM — 12, 13, 14, 16, 18, 19, 20, 21, 23, 24, 25, 27. 128 PBK — 13, 14, 15, 17, 19, 20, 21, 22, 24, 25, 26, 28. 144 PGE — 15, 16, 17, 19, 21, 22, 23, 24, 26, 27, 28, 30.

§ Slot terminals: 120 PBM — 7, 8, 9, 10, 58, 77, 97, 115. 128 PBK — 8, 9, 10, 11, 61, 82, 104, 122. 144 PGE — 10, 11, 12, 13, 68, 92, 118, 136.

¶ BUSON terminals: 120 PBM — 63, 81, 100, 119. 128 PBK — 68, 86, 107, 126. 144 PGE — 77, 96, 121, 142

Parallel terminals: 120 PBM — 35, 37, 38, 39, 40, 42. 128 PBK — 38, 40, 41, 42, 43, 45. 144 PGE — 44, 46, 47, 48, 49, 51

|| Parallel/serial terminals: 120 PBM — 43, 44, 45, 47, 48, 49, 50. 128 PBK — 46, 47, 48, 50, 51, 52, 53. 144 PGE — 52, 53, 54, 56, 57, 58, 59.

☆ Miscellaneous terminals: All terminals other than PCI, slot, BUSON, parallel, and parallel/serial.



PCI clock/reset timing requirements over recommended ranges of supply voltage and operating free-air temperature

PARAMETER		ALTERNATE SYMBOL	TEST CONDITIONS	MIN	MAX	UNITS
t_c	PCLK cycle time	t_{cyc}		15		ns
t_{wH}	PCLK high time	t_{high}		6		ns
t_{wL}	PCLK low time	t_{low}		6		ns
dv/dt	PCLK slew rate	t_r, t_f		1.5	4	V/ns
t_w	RSTIN pulse width	t_{rst}		1		ms
t_{su}	PCLK active time at end of RSTIN	$t_{rst-clk}$		100		ms

Pin definitions for 120-pin PBM package

PARAMETER	PIN NUMBER
PCI	14, 16, 18, 19, 20, 21, 25, 27
Slot	1, 2, 3, 4, 5, 7, 8, 9, 10, 52, 53, 54, 55, 57, 58, 59, 60, 64, 65, 66, 67, 69, 70, 71, 72, 73, 75, 76, 77, 78, 80, 82, 83, 84, 86, 87, 88, 91, 92, 93, 94, 96, 97, 98, 99, 102, 103, 104, 105, 106, 108, 109, 110, 111, 113, 114, 115, 116, 118, 120
BUSON	63, 81, 100, 119
Parallel	34, 35, 37, 38, 39, 40, 42
Parallel/serial	23, 24, 29, 30, 43, 44, 45, 47, 48, 49, 50
Miscellaneous	12, 13

Pin definitions for 128-pin PBK package

PARAMETER	PIN NUMBER
PCI	15, 17, 19, 20, 21, 22, 26, 28,
Slot	2, 3, 4, 5, 6, 8, 9, 10, 11, 55, 56, 57, 58, 60, 61, 62, 63, 69, 70, 71, 72, 74, 75, 76, 77, 78, 80, 81, 82, 83, 85, 87, 88, 89, 91, 92, 93, 98, 99, 100, 101, 103, 104, 105, 106, 109, 110, 111, 112, 113, 115, 116, 117, 118, 120, 121, 122, 123, 125, 127
BUSON	68, 86, 107, 126
Parallel	37, 38, 40, 41, 42, 43, 45,
Parallel/serial	24, 25, 30, 31, 46, 47, 48, 50, 51, 52, 53
Miscellaneous	13, 14

Pin definitions for 144-pin PGE package

PARAMETER	PIN NUMBER
PCI	17, 19, 21, 22, 23, 24, 28, 30
Slot	1, 3, 5, 7, 8, 10, 11, 12, 13, 61, 62, 63, 64, 66, 68, 70, 72, 79, 80, 81, 82, 84, 85, 86, 87, 88, 90, 91, 92, 93, 95, 97, 98, 99, 101, 102, 104, 109, 111, 113, 115, 117, 118, 119, 120, 123, 124, 125, 126, 127, 129, 130, 131, 132, 134, 135, 136, 137, 140, 144
BUSON	77, 96, 121, 142
Parallel	43, 44, 46, 47, 48, 49, 51
Parallel/serial	26, 27, 34, 36, 52, 53, 54, 56, 57, 58, 59
Miscellaneous	15, 16

HPC3130A

PCI HOT PLUG CONTROLLER

SCPS055 – NOVEMBER 1999

PCI timing requirements over recommended ranges of supply voltage and operating free-air temperature† (see Note 3)

PARAMETER		ALTERNATE SYMBOL	TEST CONDITIONS	MIN	MAX	UNITS	
t_{pd}	Propagation delay time	PCLK to shared signal valid delay time	t_{val}	$C_L = 50$ pF, See Note 4, 1,2,3	2	11	ns
t_{en}	Enable time, high-impedance-to-active delay time from PCLK		t_{on}		2		ns
t_{dis}	Disable time, active-to-high-impedance delay time from PCLK		t_{off}			28	ns
t_{su}	Valid setup time, before PCLK		t_{su}	3,4	3		ns
t_h	Hold time, after PCLK high		t_h	4	0		ns

† Applies to external output buffers.

- NOTES: 3. This data sheet uses the following conventions to describe time (t) intervals. The format is: t_A , where *subscript A* indicates the type of dynamic parameter being represented. One of the following is used: t_{pd} = propagation delay time, t_d = delay time, t_{su} = setup time, and t_h = hold time.
4. PCI shared signals are AD31–AD0, C/BE3–C/BE0, PCIFRAME, PCITRDY, PCIIRDY, PCISTOP, IDSEL, PCIDEVSEL, and PCIPAR.

serial bus interface†

		STANDARD MODE		FAST MODE		UNIT
		MIN	MAX	MIN	MAX	
f_{SCL}	SCL clock frequency (see Note 5)	0	100	0	400	kHz
t_{BUF}	Bus free time between a STOP and START condition	4.7		1.3		μ s
$t_{HD;STA}$	Hold time (repeated) START condition. After this period, the first clock pulse is generated.	4		0.6		μ s
t_{LOW}	LOW period of the SCL clock	4.7		1.3		μ s
t_{HIGH}	HIGH period of the SCL clock	4		0.6		μ s
$t_{SU;STA}$	Setup time for a repeated START condition	4.7		0.6		μ s
$t_{HD;DAT}$	Data hold time (see Note 6)	For CBUS compatible masters:	5			μ s
		For serial bus devices:	0 ₁		0 ₁ 0.9 ₂	
$t_{SU;DAT}$	Data setup time (see Note 7)	250		100 ₃		μ s
t_R	Rise time of both SDA and SCL signals		1000	20	300	μ s
t_F	Fall time of both SDA and SCL signals		300	20	300	μ s
$t_{FSU;STO}$	Setup time for STOP condition	4		0.6		μ s

† All values refer to serial bus interface V_{IH} MIN and V_{IL} MAX levels

- NOTES: 5. A device must internally provide a hold time of at least 300 ns for the SDA signal (referred to the V_{IH} MIN of the SCL signal) in order to bridge the undefined region of the falling edge of SCL.
6. The maximum $t_{HD;DAT}$ has only to be met if the device does not stretch the LOW period (t_{LOW}) of the SDL signal.
7. A fast mode serial bus device can be used in a standard mode serial bus system, but the requirement $t_{SU;DAT} \geq 250$ ns must then be met. This will automatically be the case if the device does not stretch the LOW period of the SCL signal. If such a device does stretch the LOW period of the SCL signal, it must output the next data bit to the SDA line t_R MAX + $t_{SU;DAT} = 1000 + 250 = 1250$ ns (according to the *Standard Mode Serial Bus Specification*) before the SCL line is released.



MECHANICAL DATA

PBM (S-PQFP-G***)

PLASTIC QUAD FLATPACK

120-PIN SHOWN

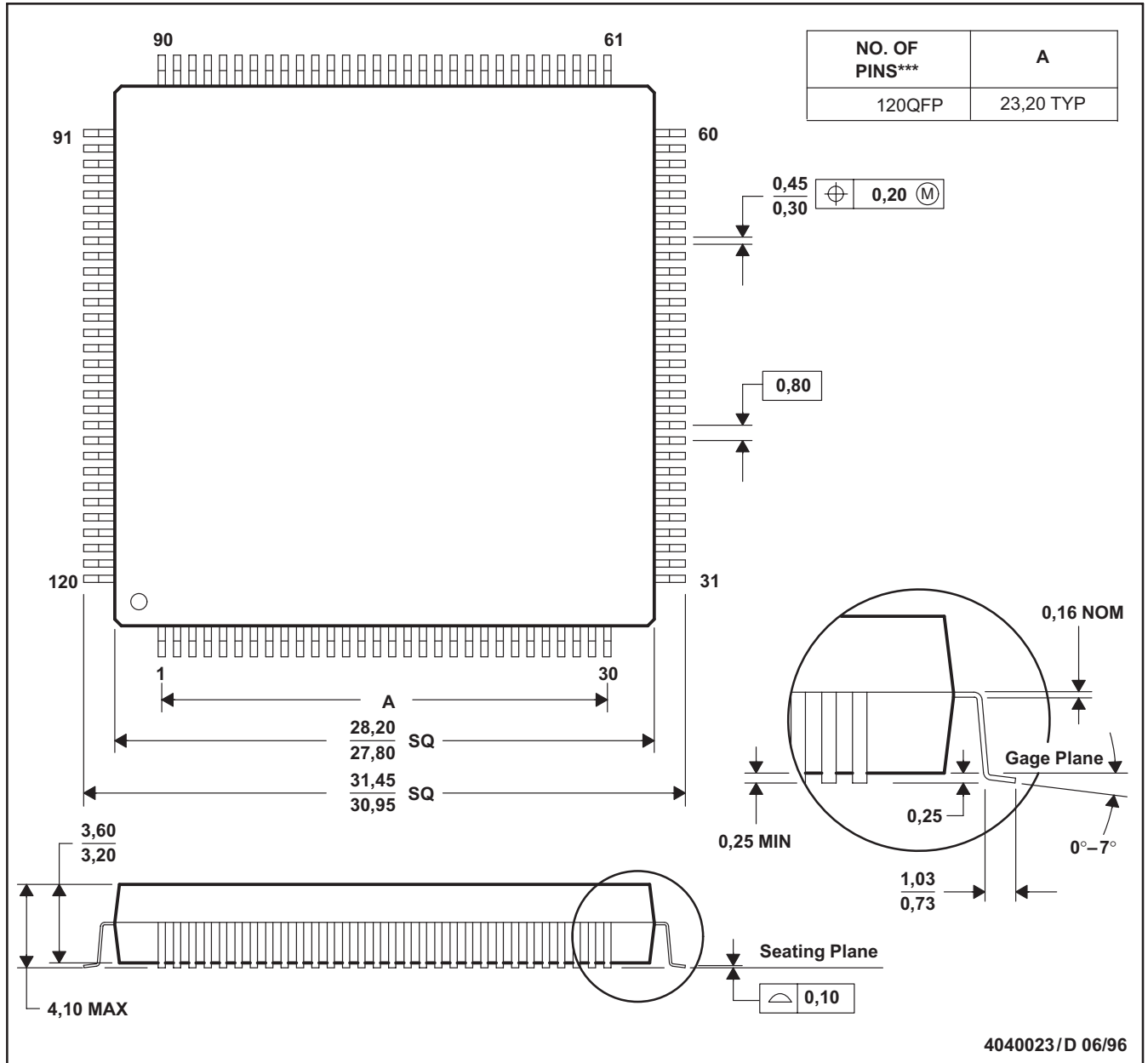

- NOTES: A. All linear dimensions are in millimeters.
 B. This drawing is subject to change without notice.
 C. Falls within JEDEC MS-022

HPC3130A PCI HOT PLUG CONTROLLER

SCPS055 – NOVEMBER 1999

MECHANICAL DATA

PBK (S-PQFP-G128)

PLASTIC QUAD FLATPACK

128-PIN SHOWN

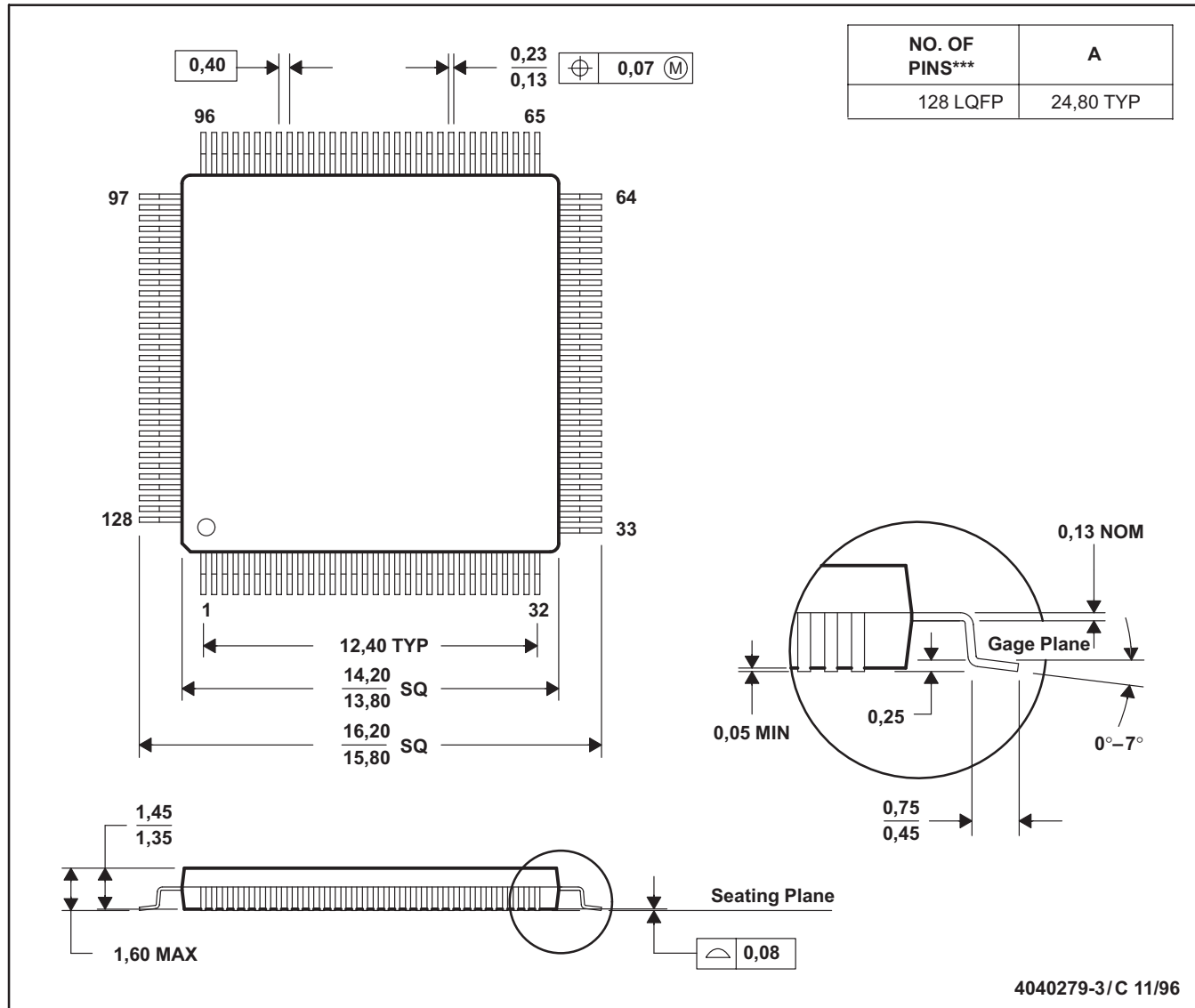

- NOTES: A. All linear dimensions are in millimeters.
 B. This drawing is subject to change without notice.
 C. Falls within JEDEC MS-026

MECHANICAL DATA

PGE (S-PQFP-G144)

PLASTIC QUAD FLATPACK

144-PIN SHOWN

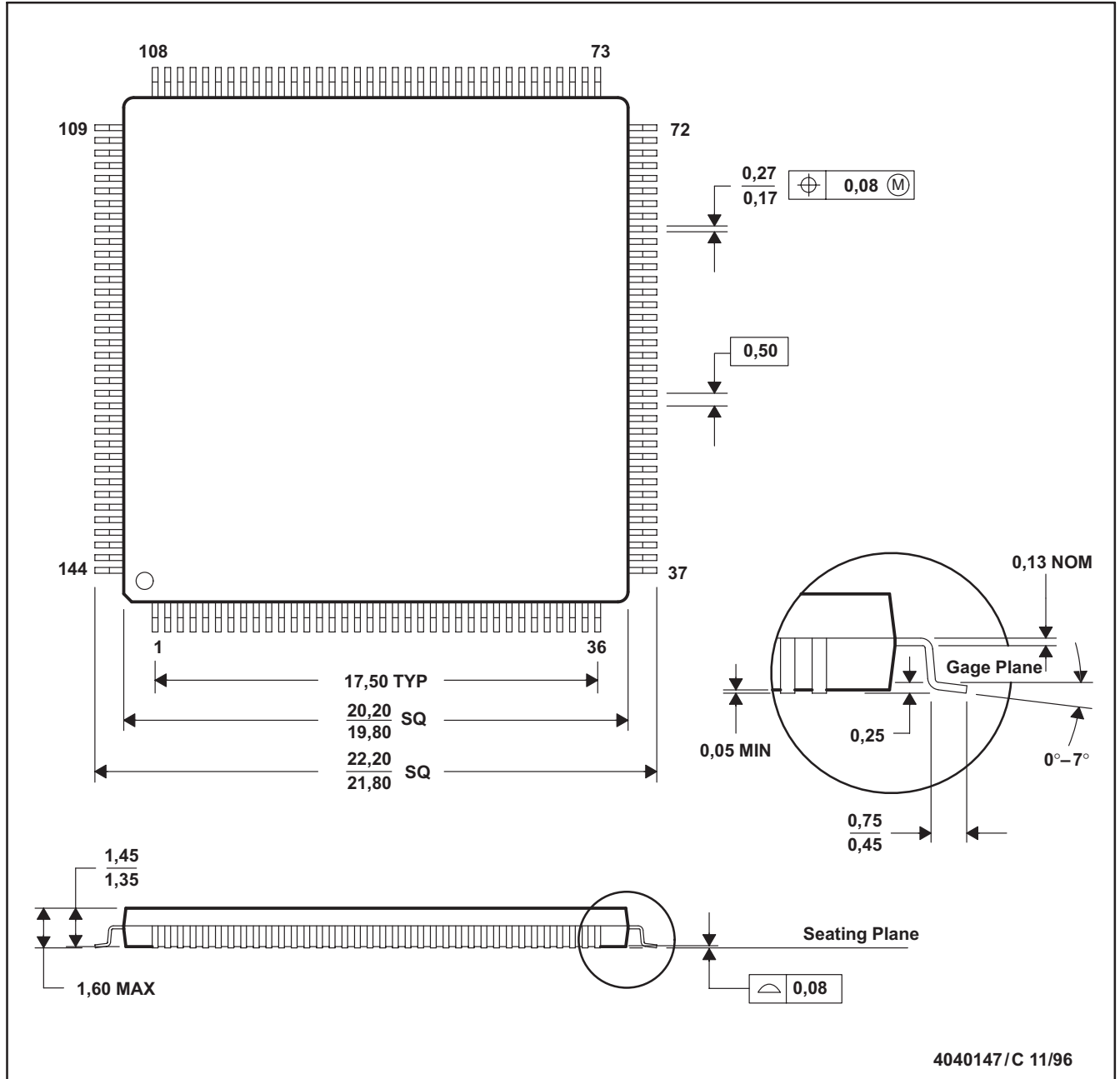

- NOTES: A. All linear dimensions are in millimeters.
 B. This drawing is subject to change without notice.
 C. Falls within JEDEC MS-026

HPC3130A

PCI HOT PLUG CONTROLLER

SCPS055 – NOVEMBER 1999

IMPORTANT NOTICE

Texas Instruments and its subsidiaries (TI) reserve the right to make changes to their products or to discontinue any product or service without notice, and advise customers to obtain the latest version of relevant information to verify, before placing orders, that information being relied on is current and complete. All products are sold subject to the terms and conditions of sale supplied at the time of order acknowledgement, including those pertaining to warranty, patent infringement, and limitation of liability.

TI warrants performance of its semiconductor products to the specifications applicable at the time of sale in accordance with TI's standard warranty. Testing and other quality control techniques are utilized to the extent TI deems necessary to support this warranty. Specific testing of all parameters of each device is not necessarily performed, except those mandated by government requirements.

CERTAIN APPLICATIONS USING SEMICONDUCTOR PRODUCTS MAY INVOLVE POTENTIAL RISKS OF DEATH, PERSONAL INJURY, OR SEVERE PROPERTY OR ENVIRONMENTAL DAMAGE ("CRITICAL APPLICATIONS"). TI SEMICONDUCTOR PRODUCTS ARE NOT DESIGNED, AUTHORIZED, OR WARRANTED TO BE SUITABLE FOR USE IN LIFE-SUPPORT DEVICES OR SYSTEMS OR OTHER CRITICAL APPLICATIONS. INCLUSION OF TI PRODUCTS IN SUCH APPLICATIONS IS UNDERSTOOD TO BE FULLY AT THE CUSTOMER'S RISK.

In order to minimize risks associated with the customer's applications, adequate design and operating safeguards must be provided by the customer to minimize inherent or procedural hazards.

TI assumes no liability for applications assistance or customer product design. TI does not warrant or represent that any license, either express or implied, is granted under any patent right, copyright, mask work right, or other intellectual property right of TI covering or relating to any combination, machine, or process in which such semiconductor products or services might be or are used. TI's publication of information regarding any third party's products or services does not constitute TI's approval, warranty or endorsement thereof.

Copyright © 1999, Texas Instruments Incorporated



POST OFFICE BOX 655303 • DALLAS, TEXAS 75265

PACKAGING INFORMATION

Orderable Device	Status ⁽¹⁾	Package Type	Package Drawing	Pins	Package Qty	Eco Plan ⁽²⁾	Lead/Ball Finish	MSL Peak Temp ⁽³⁾
HPC3130APBK	ACTIVE	LQFP	PBK	128	90	TBD	CU NIPDAU	Level-4-220C-72 HR
HPC3130APBM	ACTIVE	QFP	PBM	120	24	TBD	Call TI	Level-3-220C-168 HR
HPC3130APGE	ACTIVE	LQFP	PGE	144	60	Green (RoHS & no Sb/Br)	CU NIPDAU	Level-2-260C-1 YEAR

⁽¹⁾ The marketing status values are defined as follows:

ACTIVE: Product device recommended for new designs.

LIFEBUY: TI has announced that the device will be discontinued, and a lifetime-buy period is in effect.

NRND: Not recommended for new designs. Device is in production to support existing customers, but TI does not recommend using this part in a new design.

PREVIEW: Device has been announced but is not in production. Samples may or may not be available.

OBSOLETE: TI has discontinued the production of the device.

⁽²⁾ Eco Plan - The planned eco-friendly classification: Pb-Free (RoHS) or Green (RoHS & no Sb/Br) - please check <http://www.ti.com/productcontent> for the latest availability information and additional product content details.

TBD: The Pb-Free/Green conversion plan has not been defined.

Pb-Free (RoHS): TI's terms "Lead-Free" or "Pb-Free" mean semiconductor products that are compatible with the current RoHS requirements for all 6 substances, including the requirement that lead not exceed 0.1% by weight in homogeneous materials. Where designed to be soldered at high temperatures, TI Pb-Free products are suitable for use in specified lead-free processes.

Green (RoHS & no Sb/Br): TI defines "Green" to mean Pb-Free (RoHS compatible), and free of Bromine (Br) and Antimony (Sb) based flame retardants (Br or Sb do not exceed 0.1% by weight in homogeneous material)

⁽³⁾ MSL, Peak Temp. -- The Moisture Sensitivity Level rating according to the JEDEC industry standard classifications, and peak solder temperature.

Important Information and Disclaimer:The information provided on this page represents TI's knowledge and belief as of the date that it is provided. TI bases its knowledge and belief on information provided by third parties, and makes no representation or warranty as to the accuracy of such information. Efforts are underway to better integrate information from third parties. TI has taken and continues to take reasonable steps to provide representative and accurate information but may not have conducted destructive testing or chemical analysis on incoming materials and chemicals. TI and TI suppliers consider certain information to be proprietary, and thus CAS numbers and other limited information may not be available for release.

In no event shall TI's liability arising out of such information exceed the total purchase price of the TI part(s) at issue in this document sold by TI to Customer on an annual basis.

IMPORTANT NOTICE

Texas Instruments Incorporated and its subsidiaries (TI) reserve the right to make corrections, modifications, enhancements, improvements, and other changes to its products and services at any time and to discontinue any product or service without notice. Customers should obtain the latest relevant information before placing orders and should verify that such information is current and complete. All products are sold subject to TI's terms and conditions of sale supplied at the time of order acknowledgment.

TI warrants performance of its hardware products to the specifications applicable at the time of sale in accordance with TI's standard warranty. Testing and other quality control techniques are used to the extent TI deems necessary to support this warranty. Except where mandated by government requirements, testing of all parameters of each product is not necessarily performed.

TI assumes no liability for applications assistance or customer product design. Customers are responsible for their products and applications using TI components. To minimize the risks associated with customer products and applications, customers should provide adequate design and operating safeguards.

TI does not warrant or represent that any license, either express or implied, is granted under any TI patent right, copyright, mask work right, or other TI intellectual property right relating to any combination, machine, or process in which TI products or services are used. Information published by TI regarding third-party products or services does not constitute a license from TI to use such products or services or a warranty or endorsement thereof. Use of such information may require a license from a third party under the patents or other intellectual property of the third party, or a license from TI under the patents or other intellectual property of TI.

Reproduction of information in TI data books or data sheets is permissible only if reproduction is without alteration and is accompanied by all associated warranties, conditions, limitations, and notices. Reproduction of this information with alteration is an unfair and deceptive business practice. TI is not responsible or liable for such altered documentation.

Resale of TI products or services with statements different from or beyond the parameters stated by TI for that product or service voids all express and any implied warranties for the associated TI product or service and is an unfair and deceptive business practice. TI is not responsible or liable for any such statements.

Following are URLs where you can obtain information on other Texas Instruments products and application solutions:

Products		Applications	
Amplifiers	amplifier.ti.com	Audio	www.ti.com/audio
Data Converters	dataconverter.ti.com	Automotive	www.ti.com/automotive
DSP	dsp.ti.com	Broadband	www.ti.com/broadband
Interface	interface.ti.com	Digital Control	www.ti.com/digitalcontrol
Logic	logic.ti.com	Military	www.ti.com/military
Power Mgmt	power.ti.com	Optical Networking	www.ti.com/opticalnetwork
Microcontrollers	microcontroller.ti.com	Security	www.ti.com/security
		Telephony	www.ti.com/telephony
		Video & Imaging	www.ti.com/video
		Wireless	www.ti.com/wireless

Mailing Address: Texas Instruments
Post Office Box 655303 Dallas, Texas 75265

Looking for pricing, stock, or lifecycle information?

Click below to explore more details on WIN SOURCE:

 [View HPC3130APGE](#) on WIN SOURCE

 [Texas Instruments](#) Information

Optimize Your Supply Chain with WIN SOURCE Solutions

-  Global Sourcing Solution
-  Obsolete Management
-  Cost Control Management
-  Shortage Management
-  Alternative Solution
-  Excess Inventory Management