



THE DATASHEET OF MCP1643T-I/MC



1 MHz Low Start-up Voltage Synchronous Boost LED Constant Current Regulator

Features

- 1.6A Typical Peak Input Current Limit
- Up to 550 mA LED Load Current
- Low Start-up Voltage: 0.65V (typical, 25 mA LED Current)
- Low Operating Input Voltage: down to 0.5V
- Maximum Input Voltage <math>V_{LED} < 5.0V</math>
- Maximum Output Voltage:
 - 5.0V
 - Overvoltage Protection
- Low Reference Voltage:
 - $V_{FB} = 120\text{ mV}$
 - Minimal Power Loss on Sense Resistor
- Pulse-Width Modulation Mode Operation (1 MHz)
- Internal Synchronous Rectifier
- Internal Compensation
- Inrush Current Limiting
- Internal Soft-Start (240 μs typical)
- Shutdown (EN = GND):
 - True Load Disconnect
 - Dimming Control by Variable Duty Cycle
- Shutdown Current: 1.2 μA (typical)
- Overtemperature protection
- Packages:
 - MSOP-8
 - 2x3 DFN-8

Applications

- One and Two Cell Alkaline and NiMH/NiCd Portable LED Lighting Products
- LED Flashlight and Head Lamps
- Rechargeable Flashlights
- Wall LED Lamps with Motion Detectors
- LED supply for backlights
- General LED constant current applications

Description

MCP1643 is a compact, high-efficiency, fixed frequency, synchronous step-up converter optimized to drive one LED with constant current, that operates from one and two-cell alkaline and NiMH/NiCd batteries. The device can also drive two red/green/yellow series connection LEDs.

Low-voltage technology allows the regulator to start up without high-output voltage and load-current overshoot from a low 0.65V input. High efficiency is accomplished by integrating the low resistance N-Channel Boost switch and synchronous P-Channel switch. All compensation and protection circuitry are integrated to minimize external components.

The internal feedback (V_{FB}) voltage is set to 120 mV for low power dissipation when sensing and regulating LED current. A single resistor sets the constant current output that drives the LED load.

The device features an output overvoltage protection that limits the output voltage to 5.0V typical, in case the LED fails or output load is disconnected.

The LED will either be turned OFF or turned ON using the enable input. A True Output Load Disconnect mode provides input-to-output isolation while Shutdown (EN = GND) by removing the normal boost regulator diode path from input to output. Shutdown state consumes 1.2 μA from input at room temperature.

The LED can be turned on and off with a variable duty cycle pulse-width modulation (PWM) signal applied to the EN pin for dimming applications.

The device also features a thermal shutdown at +150°C, with +25°C hysteresis.

Two package options, MSOP-8 and 2x3 DFN-8, are available.

Package Types

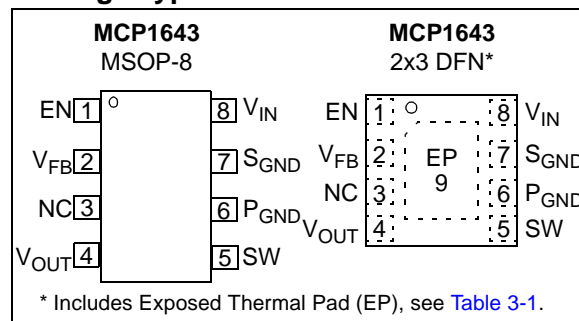

MCP1643

Typical Applications

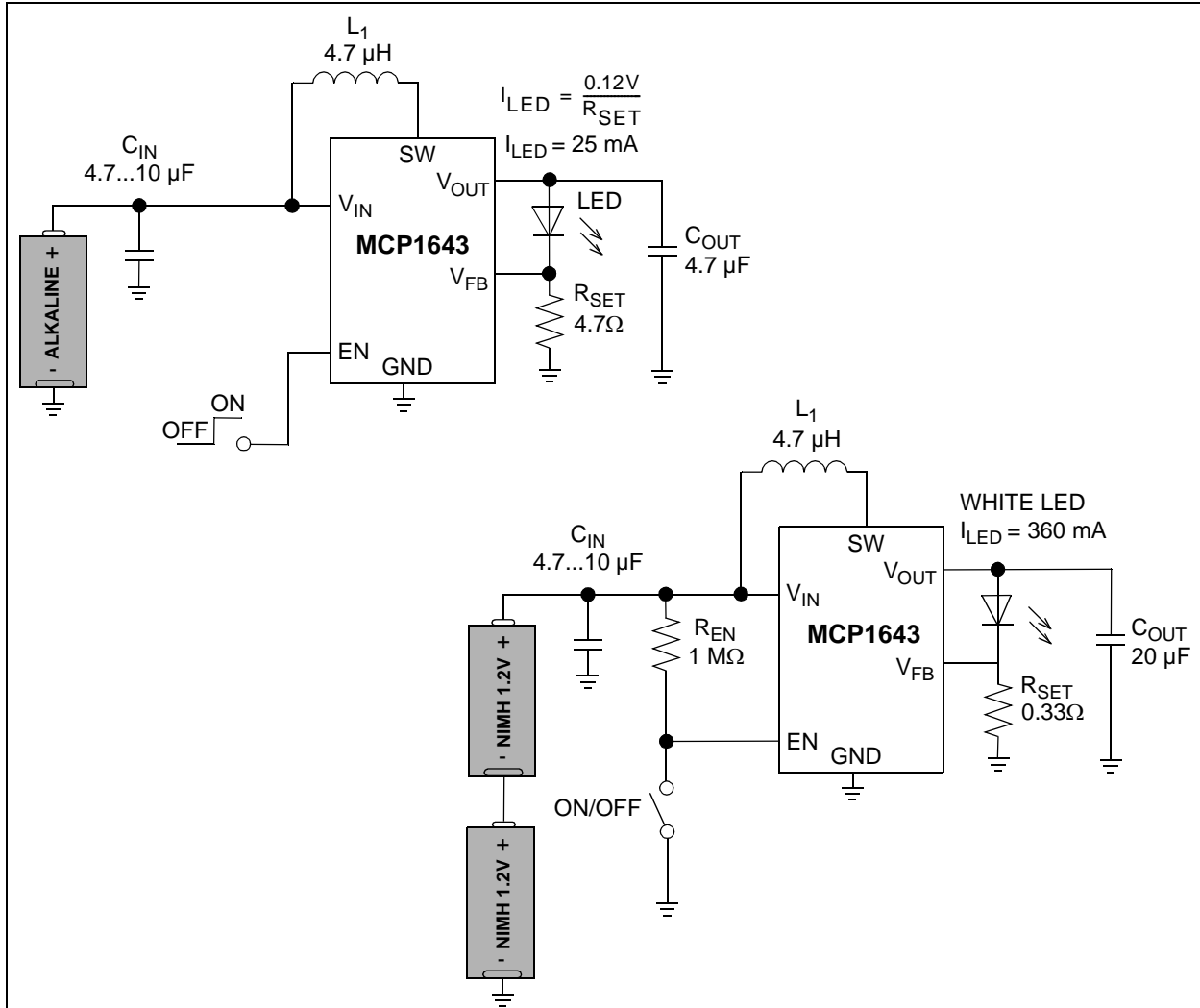

R_{SET} Minimum and Maximum Limits for I_{LED} in Regulation, with $\pm 6\%$ Tolerance

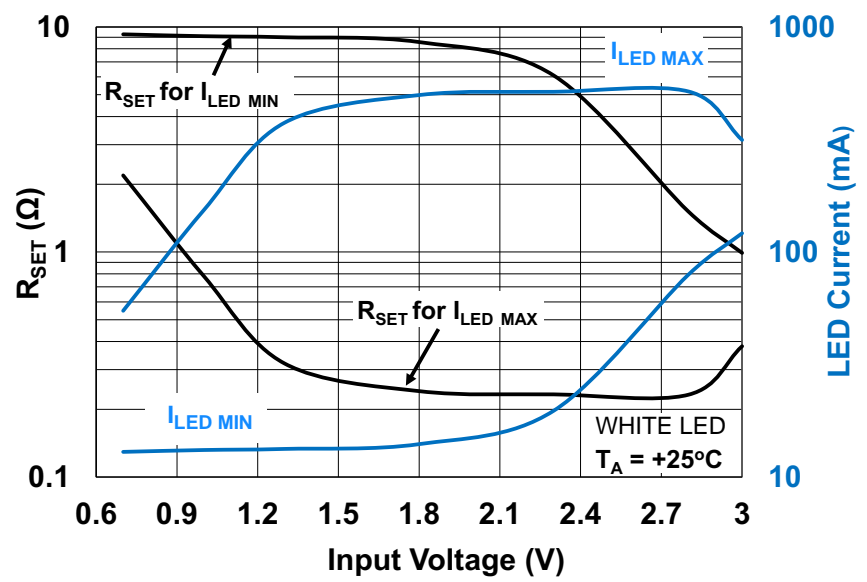

1.0 ELECTRICAL CHARACTERISTICS

Absolute Maximum Ratings †

EN, FB, V_{IN} , V_{SW} , V_{OUT} - GND.....	+6.5V
EN, FB	< maximum V_{OUT} or V_{IN} > (GND – 0.3V)
Output Short Circuit Current.....	Continuous
Power Dissipation	Internally Limited
Storage Temperature	-65°C to +150°C
Ambient Temp. with Power Applied.....	-40°C to +85°C
Operating Junction Temperature.....	-40°C to +125°C
ESD Protection On All Pins:	
HBM	4 kV
MM.....	300V

† **Notice:** Stresses above those listed under “Maximum Ratings” may cause permanent damage to the device. This is a stress rating only and functional operation of the device at those or any other conditions above those indicated in the operational sections of this specification is not intended. Exposure to maximum rating conditions for extended periods may affect device reliability.

DC CHARACTERISTICS

Electrical Characteristics: Unless otherwise indicated, $V_{IN} = EN = 1.2V$, $C_{OUT} = 20 \mu F$, $C_{IN} = 10 \mu F$, $L = 4.7 \mu H$, $I_{LED} = 25 \text{ mA}$, $T_A = +25^\circ C$. **Boldface** specifications apply over the T_A range of $-40^\circ C$ to $+85^\circ C$.

Parameters	Sym	Min	Typ	Max	Units	Conditions
Input Characteristics						
Minimum Input Voltage After Start-Up	V_{IN}	—	0.5	—	V	Note 1, Note 3
Start-Up Voltage	V_{IN}	—	0.65	0.8	V	Note 2, Note 1
Output Overvoltage Protection	V_{OUT_OVP}	—	5.0	—	V	Note 3
Shutdown Quiescent Current	I_{QSHDN}	—	1.2	—	μA	EN = GND; includes N-Channel and P-Channel Switch Leakage
Feedback Voltage	V_{FB}	105	120	135	mV	
Feedback Input Bias Current	I_{VFB}	—	60	—	pA	
NMOS Switch Leakage	I_{NLK}	—	0.4	—	μA	$V_{IN} = V_{SW} = 4.0V$ $V_{OUT} = 4.5V$ $V_{EN} = V_{FB} = GND$
PMOS Switch Leakage	I_{PLK}	—	0.25	—	μA	$V_{IN} = V_{SW} = GND$; $V_{OUT} = 4.5V$
NMOS Switch ON Resistance	$R_{DS(ON)N}$	—	0.2	—	Ω	$I_{LED} = 250 \text{ mA}$, Note 3
PMOS Switch ON Resistance	$R_{DS(ON)P}$	—	0.4	—	Ω	$I_{LED} = 250 \text{ mA}$, Note 3
NMOS Peak Switch Current Limit	$I_{N(MAX)}$	—	1.6	—	A	Note 3
Maximum Duty Cycle	DC_{MAX}	—	90	—	%	Note 3
Minimum Duty Cycle	DC_{MIN}	—	5	—	%	Note 3
Switching Frequency	f_{SW}	0.85	1.0	1.15	MHz	
EN Input Logic High	V_{IH}	75	—	—	% of V_{IN}	$I_{LED} = 25 \text{ mA}$
EN Input Logic Low	V_{IL}	—	—	20	% of V_{IN}	$I_{LED} = 25 \text{ mA}$

- Note 1:** For $V_{IN} < V_{OUT}$, I_{LED} remains in regulation up to $V_{IN} = V_{LED}$ minus a headroom @ LED typical V_F and I_F .
- 2:** V_{OUT} completely discharged. If the output capacitor remains partially charged, the device will start-up at the minimum possible voltage.
- 3:** Determined by characterization, not production tested.

MCP1643

DC CHARACTERISTICS (CONTINUED)

Electrical Characteristics: Unless otherwise indicated, $V_{IN} = EN = 1.2V$, $C_{OUT} = 20 \mu F$, $C_{IN} = 10 \mu F$, $L = 4.7 \mu H$, $I_{LED} = 25 \text{ mA}$, $T_A = +25^\circ C$. **Boldface** specifications apply over the T_A range of $-40^\circ C$ to $+85^\circ C$.

Parameters	Sym	Min	Typ	Max	Units	Conditions
EN Input Leakage Current	I_{ENLK}	—	0.9	—	μA	$V_{EN} = 1.2V$
Soft Start Time	t_{SS}	—	240	—	μs	EN Low-to-High, 90% of V_{OUT} ; $I_{LED} = 25 \text{ mA}$, Note 3
		—	270	—	μs	EN Low-to-High, 90% of V_{OUT} ; $I_{LED} = 300 \text{ mA}$, Note 3
Thermal Shutdown Die Temperature	T_{SD}	—	150	—	$^\circ C$	$I_{LED} = 25 \text{ mA}$
Die Temperature Hysteresis	T_{SDHYS}	—	25	—	$^\circ C$	

- Note 1:** For $V_{IN} < V_{OUT}$, I_{LED} remains in regulation up to $V_{IN} = V_{LED}$ minus a headroom @ LED typical V_F and I_F .
- Note 2:** V_{OUT} completely discharged. If the output capacitor remains partially charged, the device will start-up at the minimum possible voltage.
- Note 3:** Determined by characterization, not production tested.

TEMPERATURE SPECIFICATIONS

Electrical Characteristics: Unless otherwise indicated, $V_{IN} = EN = 1.2V$, $C_{OUT} = 20 \mu F$, $C_{IN} = 10 \mu F$, $L = 4.7 \mu H$, $I_{LED} = 25 \text{ mA}$, $T_A = +25^\circ C$. **Boldface** specifications apply over the T_A range of $-40^\circ C$ to $+85^\circ C$.

Parameters	Sym	Min	Typ	Max	Units	Conditions
Temperature Ranges						
Operating Ambient Temperature Range	T_A	-40	—	+85	$^\circ C$	Steady State
Storage Temperature Range	T_A	-65	—	+150	$^\circ C$	
Maximum Junction Temperature	T_J	—	—	+150	$^\circ C$	Transient
Package Thermal Resistances						
Thermal Resistance, 8L-2x3 DFN	θ_{JA}	—	68	—	$^\circ C/W$	
Thermal Resistance, 8L-MSOP	θ_{JA}	—	211	—	$^\circ C/W$	

2.0 TYPICAL PERFORMANCE CURVES

Note: The graphs and tables provided following this note are a statistical summary based on a limited number of samples and are provided for informational purposes only. The performance characteristics listed herein are not tested or guaranteed. In some graphs or tables, the data presented may be outside the specified operating range (e.g., outside specified power supply range) and therefore outside the warranted range.

Note: Unless otherwise indicated, $V_{IN} = EN = 1.2V$, $C_{OUT} = 20 \mu F$, $C_{IN} = 10 \mu F$, $L = 4.7 \mu H$, $I_{LED} = 25 \text{ mA}$, $T_A = +25^\circ C$, MSOP-8 package.

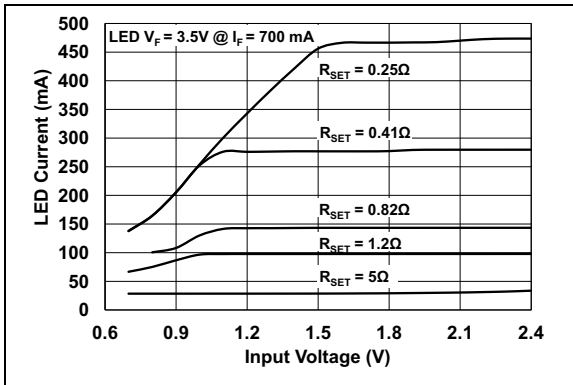

FIGURE 2-1: One White LED I_{LED} vs. V_{IN} .

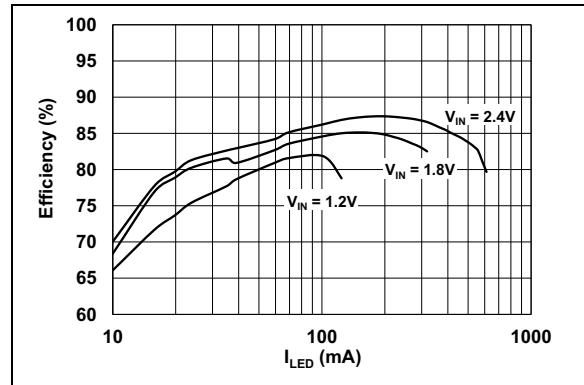

FIGURE 2-4: One White LED Efficiency vs. I_{LED} .

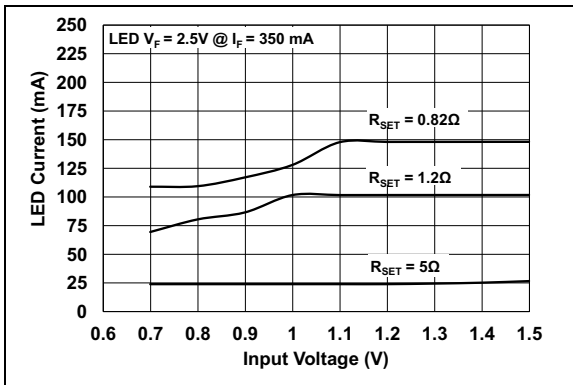

FIGURE 2-2: One Red LED I_{LED} vs. V_{IN} .

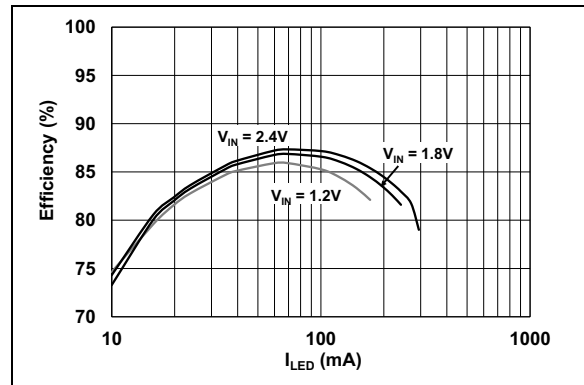

FIGURE 2-5: One Red LED Efficiency vs. I_{LED} .

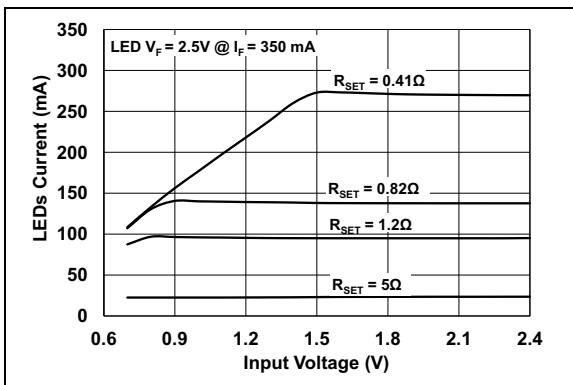

FIGURE 2-3: Two Series Connection Red LEDs I_{LED} vs. V_{IN} .

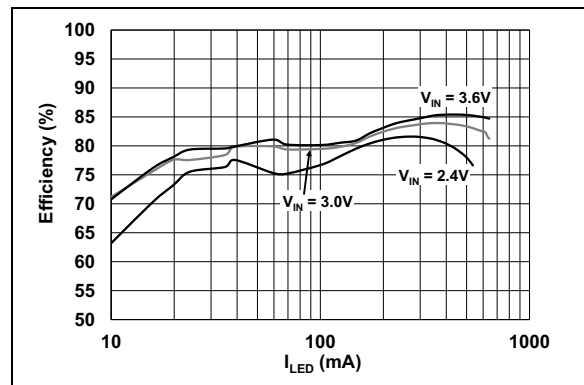

FIGURE 2-6: Two Red LEDs Efficiency (in Series Connection) vs. I_{LED} .

MCP1643

Note: Unless otherwise indicated, $V_{IN} = EN = 1.2V$, $C_{OUT} = 20 \mu F$, $C_{IN} = 10 \mu F$, $L = 4.7 \mu H$, $I_{LED} = 25 \text{ mA}$, $T_A = +25^\circ C$, MSOP-8 package.

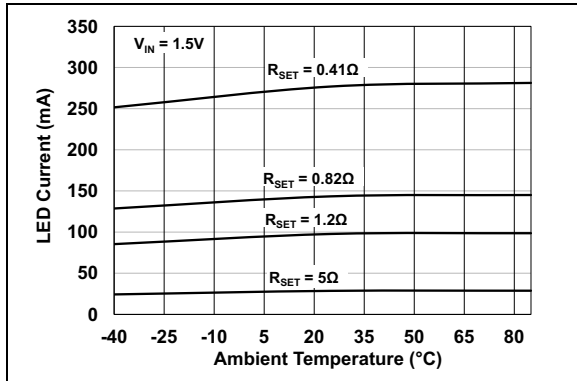

FIGURE 2-7: One White I_{LED} vs. Ambient Temperature.

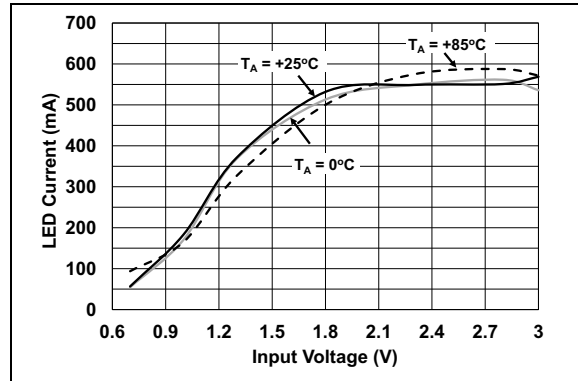

FIGURE 2-10: Maximum I_{LED} vs. V_{IN} .

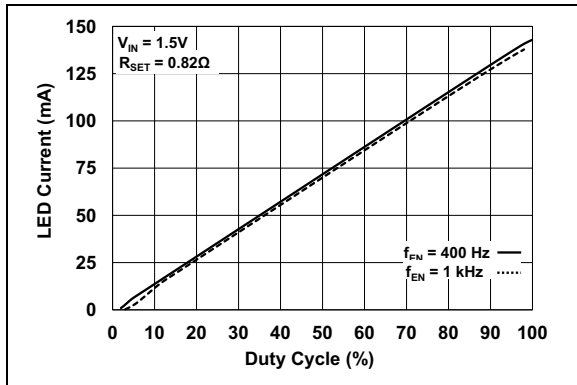

FIGURE 2-8: I_{LED} vs. V_{EN} Duty Cycle.

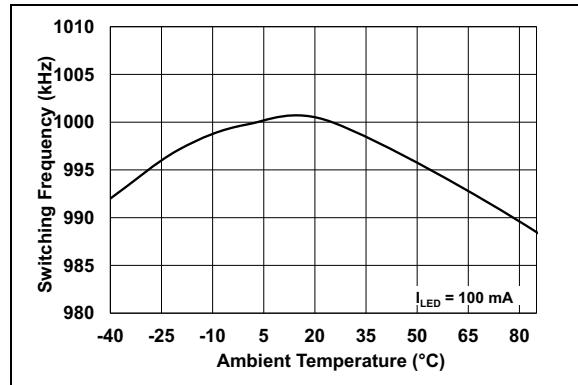

FIGURE 2-11: f_{SW} vs. Ambient Temperature.

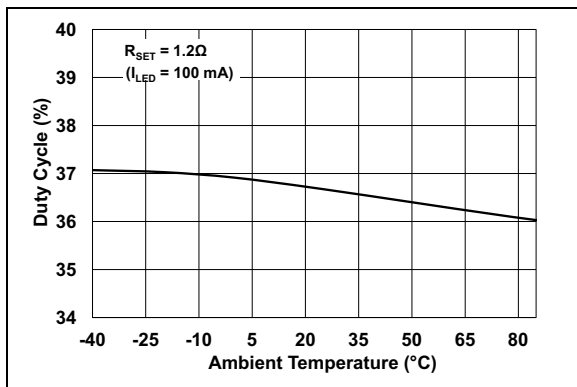

FIGURE 2-9: Duty Cycle vs. Ambient Temperature.

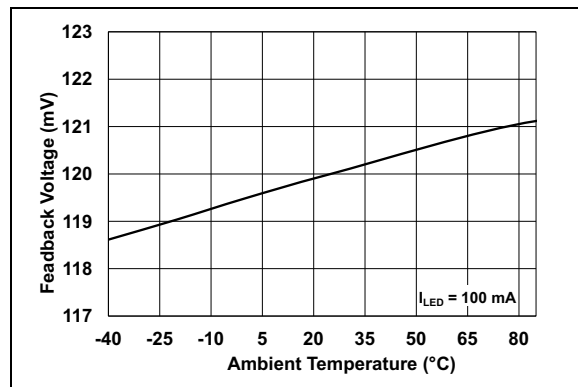

FIGURE 2-12: V_{FB} vs. Ambient Temperature.

Note: Unless otherwise indicated, $V_{IN} = V_{EN} = 1.2V$, $C_{OUT} = 20 \mu F$, $C_{IN} = 10 \mu F$, $L = 4.7 \mu H$, $I_{LED} = 25 \text{ mA}$, $T_A = +25^\circ C$, MSOP-8 package.

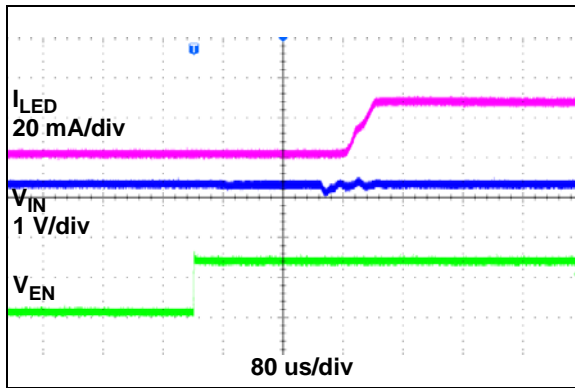

FIGURE 2-13: Start-up After Enable.

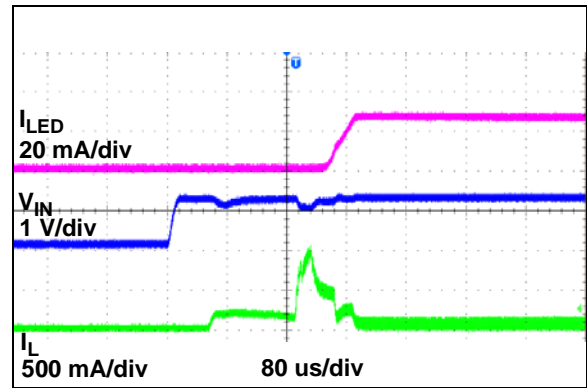

FIGURE 2-16: Start-up when $V_{IN} = V_{EN}$.

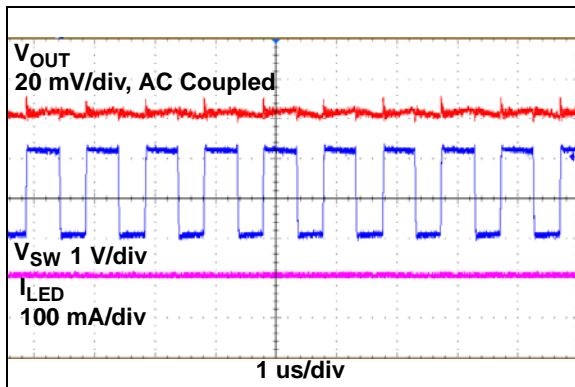

FIGURE 2-14: 100 mA PWM Operation.

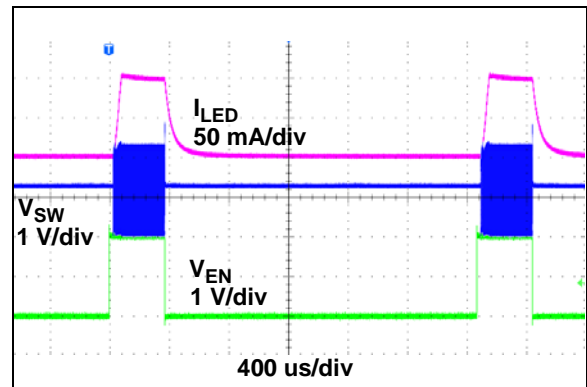

FIGURE 2-17: 400 Hz PWM Dimming, 15% Duty Cycle.

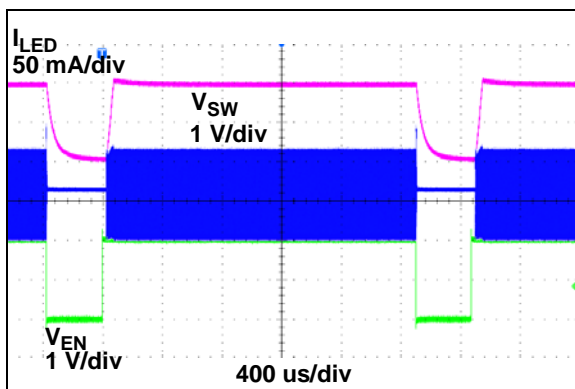

FIGURE 2-15: 400 Hz PWM Dimming, 85% Duty Cycle.

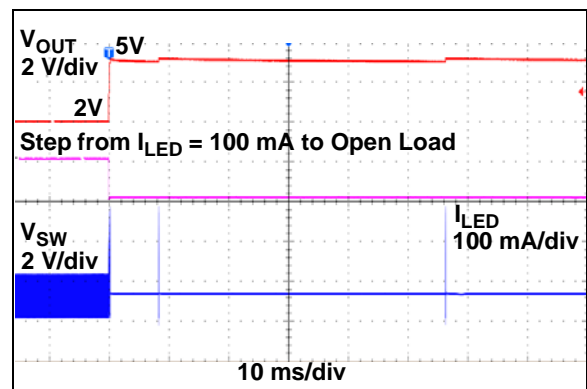

FIGURE 2-18: Open Load Response.

MCP1643

NOTES:

3.0 PIN DESCRIPTIONS

The descriptions of the pins are listed in [Table 3-1](#).

TABLE 3-1: PIN FUNCTION TABLE

MCP1643 2 x 3 DFN	MCP1643 MSOP	Symbol	Description
1	1	EN	Enable pin. The logic high enables the operation. Do not allow this pin to float.
2	2	V _{FB}	Reference Voltage pin. Connect to the V _{FB} pin, the R _{SET} (LED current set resistor), and the cathode of the LED load.
3	3	NC	Unconnected pin
4	4	V _{OUT}	Boost Converter Output pin. Connect to this pin the anode of the LED load. An output filter capacitor is required.
5	5	SW	Boost and Rectifier Switch Input pin. Connect the boost inductor between SW and V _{IN} .
6	6	P _{GND}	Power Ground Reference pin
7	7	S _{GND}	Signal Ground Reference pin
8	8	V _{IN}	Input Supply Voltage pin. A local bypass capacitor is required.
9	—	EP	Exposed Thermal Pad, must be connected to V _{SS}

3.1 Enable Pin (EN)

The EN pin is a logic-level input used to enable or disable device switching. Device has low quiescent current while disabled. A logic high (>75% of V_{IN}) will enable the regulator output. A logic low (<20% of V_{IN}) will ensure that the regulator is disabled.

3.2 Feedback Voltage Pin (V_{FB})

The V_{FB} pin is used to regulate the voltage across the R_{SET} sense resistor to 120 mV, to keep the output LED current in regulation.

3.3 Unconnected Pin (NC)

This pin is unconnected.

3.4 Output Voltage Power Pin (V_{OUT})

High current flows through the integrated P-Channel and out of this pin to the output capacitor, LED load and R_{SET} sense resistor. The output voltage must be filtered using a 4.7 to 20 µF X7R or X5R ceramic capacitor. The value of the output capacitor depends on the load current.

3.5 Switch Node Pin (SW)

Connect the inductor from the input voltage to the SW pin. The SW pin carries inductor current and can be as high as 1.6 A typical peak value. The integrated N-Channel switch drain and integrated P-Channel switch source are internally connected at the SW node.

3.6 Power Ground (P_{GND}) and Signal Ground Pins (S_{GND})

The power ground pins are used as a return for the high-current N-Channel switch.

The signal ground pin is used as a return for the integrated V_{FB} and error amplifier.

The length of the trace from input cap return, output cap return and P_{GND} and S_{GND} should be made as short as possible to minimize noise on the ground pins.

The S_{GND} and P_{GND} pins are connected externally.

3.7 Power Supply Input Voltage Pin (V_{IN})

Connect the input voltage source to V_{IN}. The input source should be decoupled to GND with a 4.7 µF minimum capacitor.

3.8 Exposed Thermal Pad (EP)

There is no internal electrical connection between the Exposed Thermal Pad (EP) and the P_{GND} and S_{GND} pins. They must be connected to the same potential on the Printed Circuit Board (PCB).

MCP1643

NOTES:

4.0 DETAILED DESCRIPTION

4.1 Device Overview

The MCP1643 is capable of starting up with a low voltage, while achieving high efficiency to drive one or more LEDs with constant current.

The MCP1643 is a fixed frequency, synchronous step-up converter, with a low voltage reference of 120 mV, optimized to keep the output current constant by regulating the voltage across the feedback resistor (R_{SET}).

The normal boost converter with a high voltage reference has a high voltage drop across the current sense resistor. The power dissipated in the sense resistor reduces the efficiency of a LED driver solution. Therefore, the voltage drop on the sense resistor used to regulate the LED current must be low, in this case by a low V_{FB} value of 120 mV.

The device can operate from one or two-cell alkaline and NiMH/NiCd batteries. The maximum input voltage is 5.0V. The device features an Overvoltage Protection

that protects the device if the output voltage (V_{OUT}) is higher than 5.0V. This usually happens if the LED is disconnected. While $V_{IN} < V_{OUT}$, the load current (I_{LED}) remains in regulation until V_{IN} is close to V_{LED} (see [Typical Applications](#) and [Figures 2-1 to 2-3](#)).

A True Output Load Disconnect mode provides input-to-output isolation while in Shutdown ($EN = GND$). In this state, the MCP1643 LED driver drains 1.2 μA current from the battery at room temperature.

A high level of integration lowers the total system cost, eases the implementation and reduces board area. The device also features internal compensation, low noise, soft start and thermal shutdown.

4.2 Functional Description

The MCP1643 is a compact, high-efficiency, fixed frequency, step-up DC-DC converter that operates as a constant current generator for applications powered by either one or two-cell, alkaline, NiCd, or NiMH batteries.

[Figure 4-1](#) depicts the functional block diagram of the MCP1643 device.

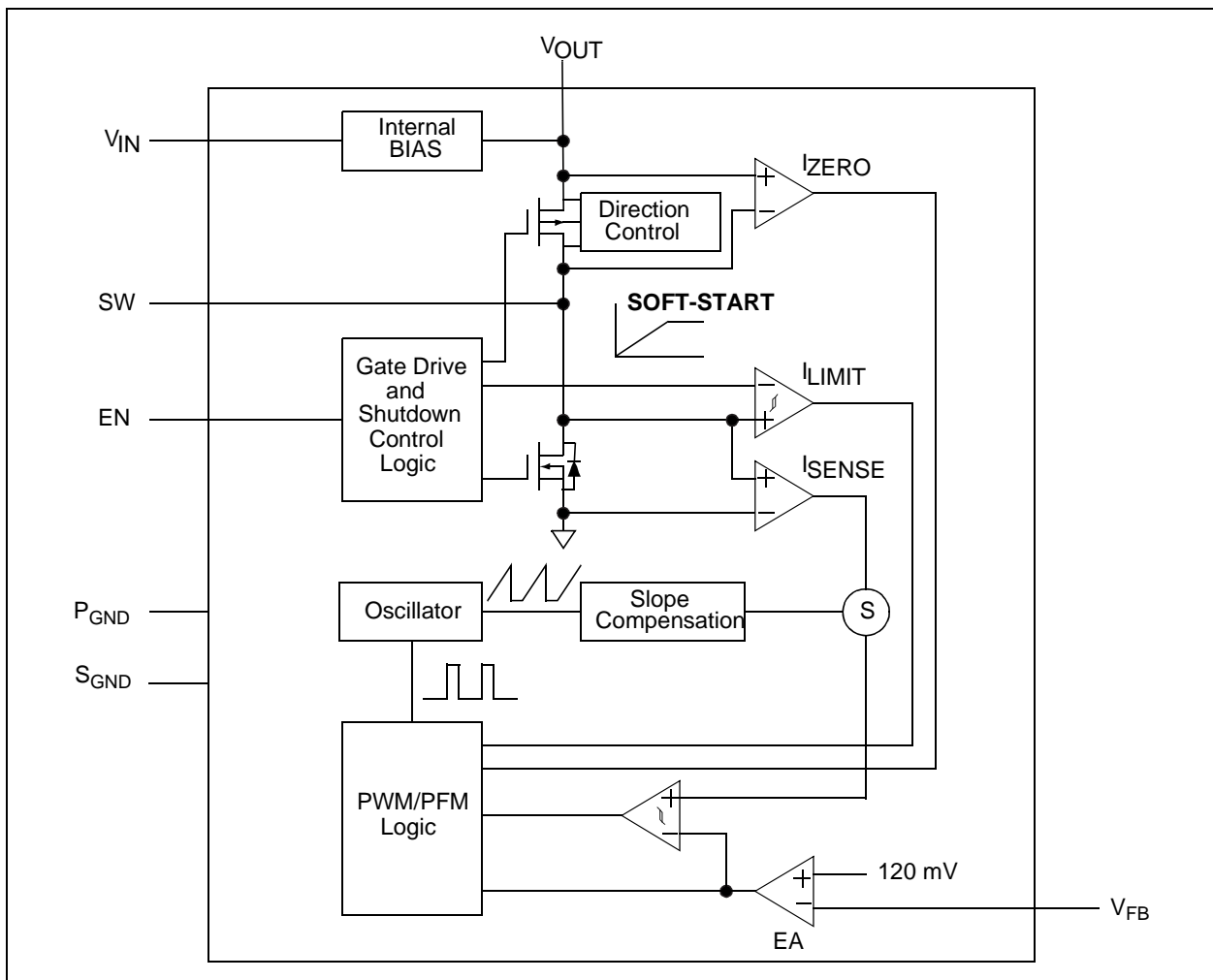

FIGURE 4-1: MCP1643 Block Diagram.

MCP1643

4.2.1 LOW-VOLTAGE START-UP

The MCP1643 LED Constant Current Driver is capable of starting from a low-input voltage. Start-up voltage is typically 0.65V for a 25 mA LED load.

For applications in which the device turns on and off fast, the start-up voltage is lower than 0.65V, because the output capacitor remains partially charged. After start-up, the device operates down to 0.5V input.

There is no Undervoltage-Lockout feature for the MCP1643 LED Constant Current Driver. The device will start up at the lowest possible voltage and run down to the lowest possible voltage.

When enabled, the internal start-up logic turns the rectifying P-Channel switch on until the output capacitor is charged to a value close to the input voltage. The rectifying switch is current limited during this time. After charging the output capacitor to the input voltage, the device starts switching in open loop, because the LED is turned off and the feedback input voltage is zero. Once V_{OUT} is equal to the minimum forward voltage (V_F) of the LED, the device enters in close loop and regulates the voltage across the R_{SET} resistor, which is connected between V_{FB} pin and GND.

4.2.2 PWM MODE OPERATION

The MCP1643 LED Constant Current Driver operates as a fixed frequency, synchronous boost converter. The switching frequency is internally maintained with a precision oscillator typically set to 1 MHz. Because the LEDs require high currents, the device will work in PWM Continuous mode. At very low LED currents, the MCP1643 might run in PWM Discontinuous mode. As it features an anti-ringing control, the switching noise is low. The P-Channel switch acts as a synchronous rectifier, by turning off to prevent reverse current flow from the output cap back to the input in order to keep efficiency high.

Lossless current sensing converts the peak current signal to a voltage to sum with the internal slope compensation. This summed signal is compared to the voltage error amplifier output to provide a peak current control command for the PWM signal. The slope compensation is adaptive to the input and output voltage. Therefore, the converter provides the proper amount of slope compensation to ensure stability, but is not excessive, which causes a loss of phase margin. The peak current limit is set to 1.6 A typical.

4.2.3 ADJUSTABLE OUTPUT LED CURRENT

The MCP1643 LED's current is adjustable with an external resistor, called R_{SET} , connected to V_{FB} pin and GND.

The device regulates the voltage on the R_{SET} and provides a constant current through LED while $V_{IN} \leq V_{OUT}$ (minus a 300 – 400 mV headroom in case of low LED currents) (see [Figures 2-1](#) and [2-2](#)).

The internal V_{REF} voltage is 120 mV. There are limits applied when the R_{SET} value is calculated over the input voltages (see [Typical Applications](#)).

4.2.4 ENABLE

The enable pin is used to turn the boost converter on and off. The enable threshold voltage varies with input voltage. To enable the boost converter, the EN voltage level must be greater than 75% of the V_{IN} voltage. To disable the boost converter, the EN voltage must be less than 20% of the V_{IN} voltage.

4.2.4.1 True Output Disconnect

The MCP1643 device incorporates a true output disconnect feature. With the EN pin pulled low, the output of the MCP1643 is isolated or disconnected from the input by turning off the integrated P-Channel switch and removing the switch bulk diode connection. This removes the DC path, typical in boost converters, which allows the output to be disconnected from the input. During this mode, 1.2 μ A (typical) of current is consumed from the input (battery). True output disconnect does not discharge the output; this allows a faster start-up in dimming or load step applications.

4.2.4.2 PWM Dimming

The MCP1643 allows dimming by turning the LED on and off with a variable duty cycle PWM signal applied to the EN pin. The maximum frequency for dimming is limited by the internal soft-start of 240 μ s (typical). By varying the duty cycle of the PWM signal applied on EN input, the LED current is changing linearly (see [Figure 2-8](#)).

4.2.5 INTERNAL BIAS

The MCP1643 LED Constant Current Driver gets its start-up bias from V_{IN} . Once the output exceeds the input, bias comes from the output. Therefore, once started, the operation is completely independent of V_{IN} . The operation is only limited by the output power level and the input source series resistance. Once started, the output will remain in regulation, down to 0.5V typical with 25 mA LED current for low-source impedance inputs.

4.2.6 INTERNAL COMPENSATION

The error amplifier, with its associated compensation network, completes the closed loop system by comparing the voltage from the sense resistor to a 120 mV reference at the input of the error amplifier and feeding the amplified and inverted signal to the control input of the inner current loop. The compensation network provides phase leads and lags at appropriate frequencies to cancel excessive phase lags and leads of the power circuit. All necessary compensation components and slope compensation are integrated.

4.2.7 SHORT CIRCUIT PROTECTION

Unlike most boost converters, the MCP1643 LED Constant Current Driver allows its output to be shorted during normal operation. The internal current limit and overtemperature protection limit excessive stress and protect the device during periods of short circuit, overcurrent and overtemperature.

4.2.8 OUTPUT OVERVOLTAGE PROTECTION

Overvoltage Protection is designed to protect the MCP1643 if the output voltage (V_{OUT}) becomes higher than 5.0V. Because the device is a step-up converter that runs as a constant current generator, if the load is disconnected, the output increases up to dangerous voltages. This happens when the LED fails. The device stops switching and the V_{OUT} value is verified periodically if it is higher than 5.0V (see [Figure 2-18](#)).

This feature does not protect the LED. An optional Zener diode is added between V_{OUT} and V_{FB} pins to clamp the output voltage and protects the LED against excessive voltage and current.

4.2.9 OVERTEMPERATURE PROTECTION

Overtemperature protection circuitry is integrated in the MCP1643 LED Constant Current Driver. This circuitry monitors the device junction temperature and shuts the device off if the junction temperature exceeds the typical +150°C threshold. If this threshold is exceeded, the device will automatically restart once the junction temperature drops by 25°C.

MCP1643

NOTES:

5.0 APPLICATION INFORMATION

5.1 Typical Applications

The MCP1643 synchronous boost regulator operates at 0.5V input. The maximum output voltage range is limited by overvoltage protection at 5.0V. LED current stays in regulation while $V_{IN} \leq V_{OUT}$ minus a 300 – 400 mV headroom. The power efficiency conversion is high when driving LED currents up to hundreds of mA. Output current capability is limited by the 1.6A typical peak input current limit. Typical characterization curves in this data sheet are presented to display the typical output current capability.

5.2 LED Brightness Control

5.2.1 ADJUSTABLE CONSTANT CURRENT CALCULATIONS

To calculate the resistor values for the MCP1643's LED current, use [Equation 5-1](#), where R_{SET} is connected to V_{FB} and GND. The reference voltage (V_{FB}) is 120 mV.

EQUATION 5-1:

$$I_{LED} = \frac{V_{FB}}{R_{SET}}$$

EXAMPLE 1:

$$\begin{aligned} V_{FB} &= 120 \text{ mV} \\ I_{LED} &= 25 \text{ mA} \\ R_{SET} &= 4.8\Omega \text{ (with a standard value of } 4.7\Omega, \\ & \quad I_{LED} \text{ is } 25.53 \text{ mA)} \end{aligned}$$

EXAMPLE 2:

$$\begin{aligned} V_{FB} &= 120 \text{ mV} \\ I_{LED} &= 100 \text{ mA} \\ R_{SET} &= 1.2\Omega \end{aligned}$$

Power dissipated on the R_{SET} resistor is very low and equal with $V_{FB} \cdot I_{LED}$. For 100 mA LED current, the power dissipated on sense resistor is only 12 mW, and the efficiency of the conversion is high.

[Equation 5-1](#) applies for one or even two LEDs in series connection. The [Typical Applications](#) graphic shows the maximum and minimum limits for R_{SET} over the input voltage range that ensures current regulation for a white LED.

5.2.2 PWM DIMMING

LED's brightness can also be controlled by setting a maximum current allowed for LED (using [Equation 5-1](#)) and lowering it in small steps with a variable duty cycle PWM signal applied to the EN pin. The maximum frequency for dimming is limited by the soft start, which varies with the LED current. By varying the duty cycle of the signal applied on the EN pin (from 0 to 100%), the LED current is changing linearly (see [Figure 2-8](#)).

5.3 Input Capacitor Selection

The boost input current is smoothed by the boost inductor, reducing the amount of filtering necessary at the input. Some capacitance is recommended to provide decoupling from the source. Low ESR X5R or X7R are well suited, since they have a low temperature coefficient and small size. For most applications, 4.7 μ F of capacitance is sufficient at the input. For high-power applications that have high-source impedance or long leads, connecting the battery to 10 μ F capacitance is recommended. Additional input capacitance can be added to provide a stable input voltage.

5.4 Output Capacitor Selection

The output capacitor helps provide a stable output voltage and smooth load current during sudden load transients, as is the PWM dimming. Ceramic capacitors are well suited for this application (X5R and X7R). The range of the output capacitor vary from 4.7 μ F (in case of light loads and static applications) up to 20 μ F (for hundreds of milliamp LED currents and PWM dimming applications).

5.5 Connecting More LEDs to Output

White LEDs have a typical 2.7 to 3.2V forward voltage (V_F), which depends on the power dissipated according to its V_F/I_F characteristic. Because MCP1643 allows up to 5.0V maximum to output, two white LEDs in series connection are not possible.

Two or more white LEDs can be connected in parallel to output, as shown in [Figure 6-1](#). Current sensing is necessary only for one LED. Each LED of the string is passed by the calculated current according to [Equation 5-1](#). A protection circuit formed by a Zener and general purpose diodes will protect the rest of LEDs, if the LED in the sense loop fails.

Two red, green or yellow LEDs can be connected in series to the output of MCP1643 (see application example on [Figure 6-2](#)). Red LEDs have a typical V_F between 1.8V and 2.2V (it depends on the real color), yellow LEDs have the V_F between 2.1V and 2.2V, while for green options, consider values from 2.0V to 2.4V.

MCP1643

5.6 Inductor Selection

The MCP1643 device is designed to be used with small surface mount inductors. An inductance value of 4.7 μH is recommended to achieve a good balance between the inductor size, converter load transient response and minimized noise.

TABLE 5-1: MCP1643 RECOMMENDED INDUCTORS

Part Number	Value (μH)	DCR (Ω – typ)	I_{SAT} (A)	Size WxLxH (mm)
Würth® Group				
744025004	4.7	0.100	1.7	2.8x2.8x2.8
744042004	4.7	0.082	1.65	4.8x4.8x1.8
Coilcraft				
ME3220	4.7	0.190	1.5	2.5x3.2x2.0
LPS4018	4.7	0.125	1.8	4x4x1.8
XFL4020	4.7	0.052	2.0	4x4x2.1
TDK Corporation				
B82462 G4472M	4.7	0.04	1.8	6x6x3
B82462 A4472M	4.7	0.08	2.8	6x6x3
SLF6028-4R7M1R6	4.7	0.028	1.6	6x6x2.8

Several parameters are used to select the correct inductor:

- maximum-rated current
- saturation current
- copper resistance (ESR)

For boost converters, the inductor current can be much higher than the output current. The lower the inductor ESR, the higher the efficiency of the converter, a common trade-off in size versus efficiency.

The saturation current typically specifies a point at which the inductance has rolled off a percentage of the rated value. This can range from a 20% to 40% reduction in inductance. As the inductance rolls off, the inductor ripple current increases, as does the peak switch current. It is important to keep the inductance from rolling off too much, causing switch current to reach the peak limit.

5.7 Thermal Calculations

The MCP1643 is available in two different packages: MSOP-8 and 2 x 3 DFN-8. By calculating the power dissipation and applying the package thermal resistance (θ_{JA}), the junction temperature is estimated. The maximum continuous ambient temperature rating for the MCP1643 family of devices is +85°C.

To quickly estimate the internal power dissipation for the switching boost regulator, an empirical calculation using measured efficiency can be used. Given the measured efficiency, the internal power dissipation is estimated by [Equation 5-2](#):

EQUATION 5-2:

$$\left(\frac{V_{\text{OUT}} \times I_{\text{OUT}}}{\text{Efficiency}} \right) - (V_{\text{OUT}} \times I_{\text{OUT}}) = P_{\text{Dis}}$$

The difference between the first term, input power, and the second term, power delivered, is the internal MCP1643's power dissipation. This is an estimate assuming that most of the power lost is internal to the MCP1643 device and not C_{IN} , C_{OUT} and the inductor. There is some percentage of power lost in the boost inductor, with very little loss in the input and output capacitors. For a more accurate estimation of the internal power dissipation, subtract the $I_{\text{INRMS}}^2 \times L_{\text{DCR}}$ power dissipation.

5.8 PCB Layout Information

Good printed circuit board layout techniques are important to any switching circuitry, and switching power supplies are no different. When wiring the switching high current paths, short and wide traces should be used. For the MCP1643, these paths are from V_{IN} pin to the V_{OUT} , output capacitor, LED load, R_{SET} sense resistor, and S_{GND} and P_{GND} pins to the input capacitor. Therefore, it is important that the input and output capacitors be placed as close as possible to the MCP1643, to minimize the loop area.

The feedback track should be routed away from the switching node and close to the V_{FB} pin. R_{SET} must be connected as close as possible to the V_{FB} pin, unless regulation issues appears. When possible, ground planes and traces should be used to help shield the feedback signal and minimize noise and magnetic interference.

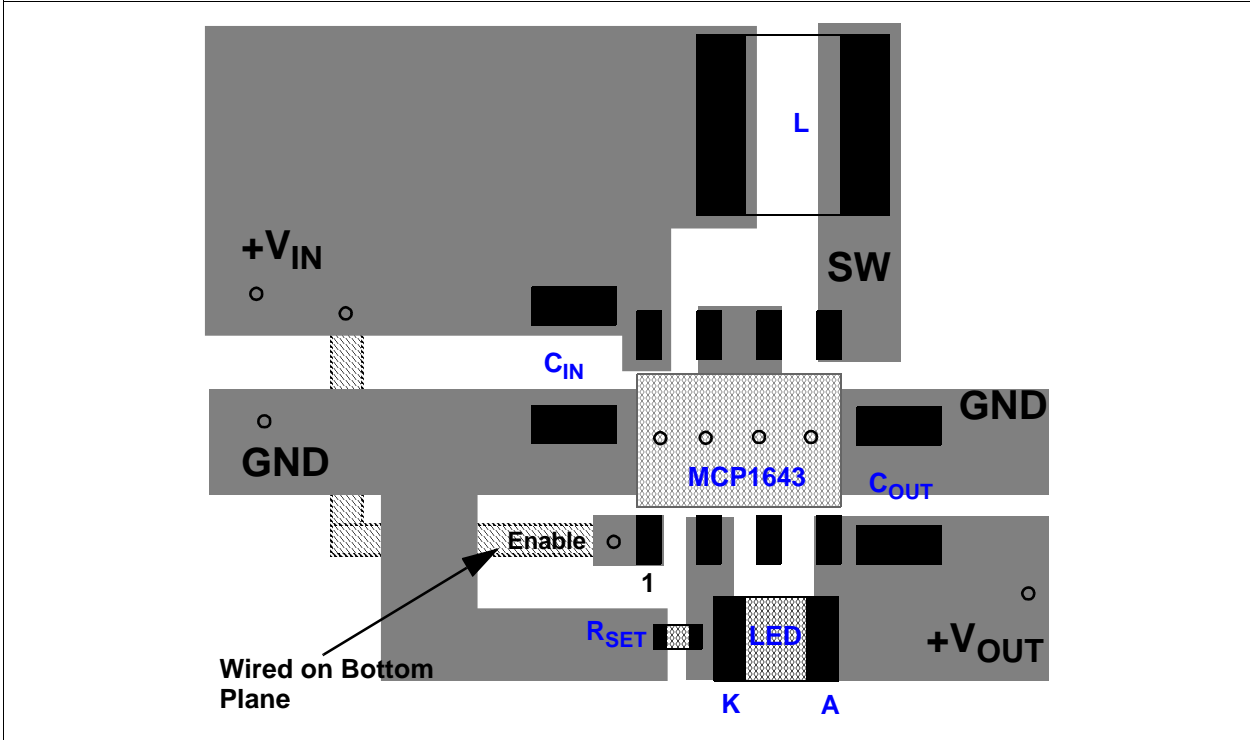

FIGURE 5-1: MCP1643 LED Constant Current Driver MSOP8 Recommended Layout. Apply the same guidance for 8-DFN package.

MCP1643

NOTES:

6.0 TYPICAL APPLICATION CIRCUITS

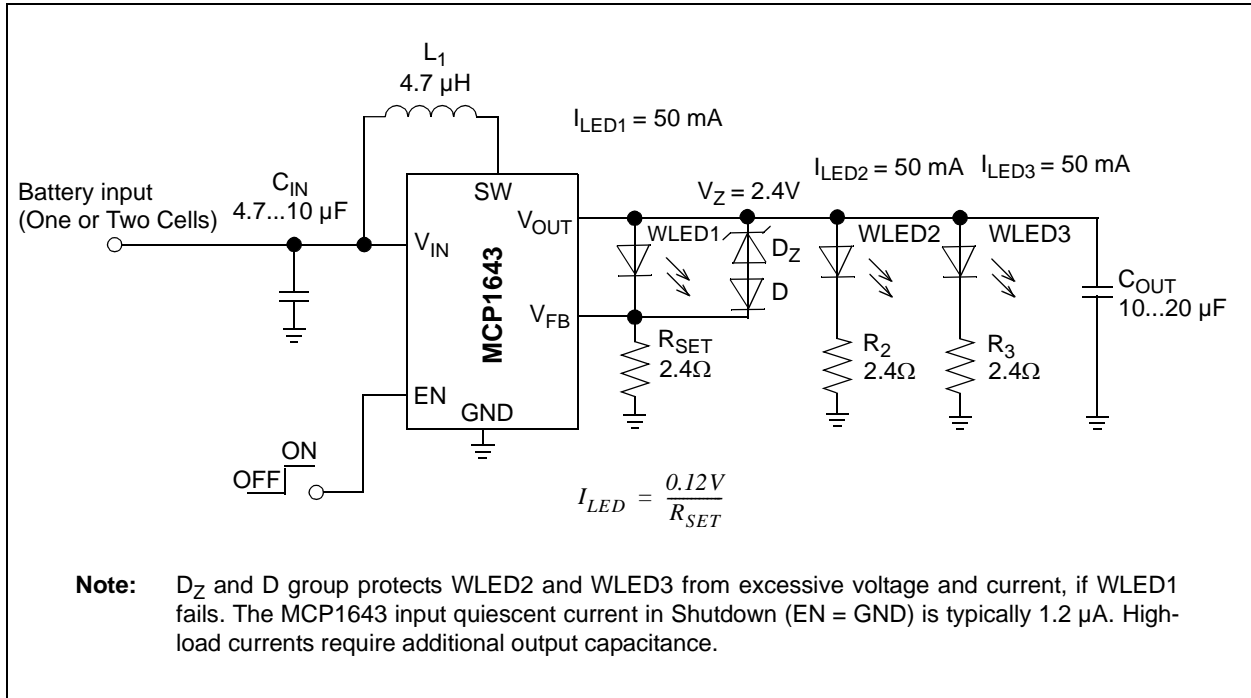

FIGURE 6-1: Three White LEDs Application Powered from One or Two Cells.

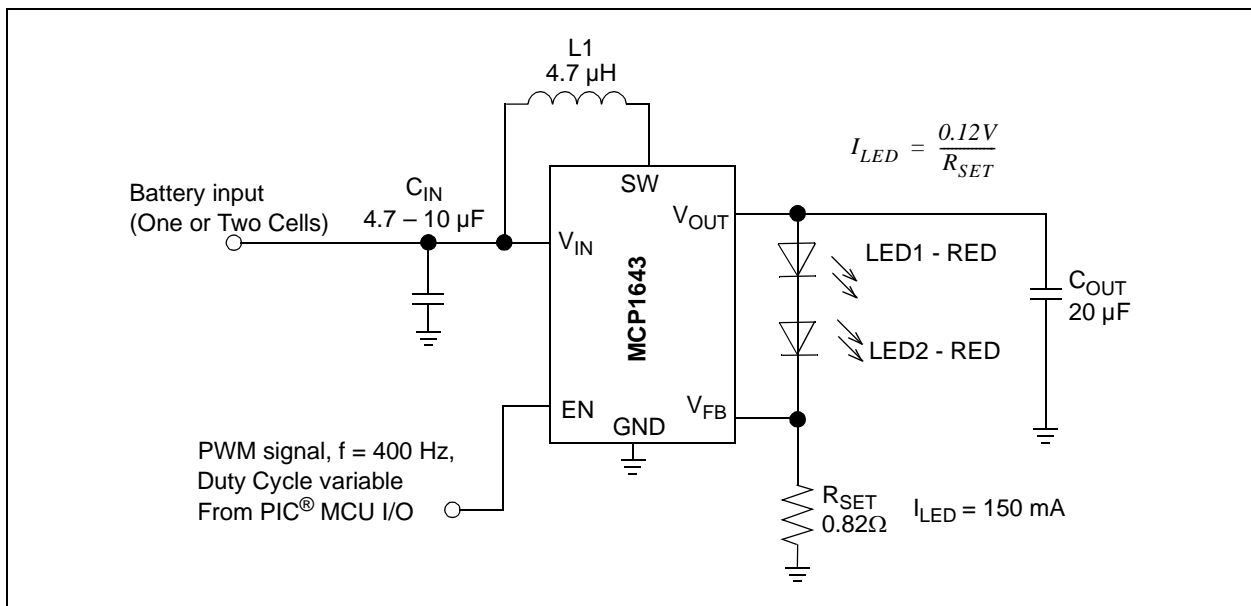

FIGURE 6-2: 150 mA Two Power Red LEDs Driver with PWM Dimming Control from PIC® Microcontroller.

MCP1643

NOTES:

7.0 PACKAGING INFORMATION

7.1 Package Marking Information

8-Lead DFN (2 x 3 x 0.9 mm)



Part Number	Code
MCP1643-I/MC	AKF
MCP1643T-I/MC	AKF

Example

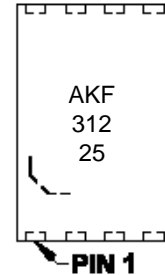

8-Lead MSOP



Part Number	Code
MCP1643-I/MS	1643I
MCP1643T-I/MS	1643I

Example

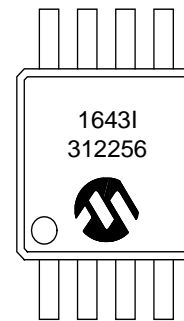

Legend:	XX...X	Customer-specific information
	Y	Year code (last digit of calendar year)
	YY	Year code (last 2 digits of calendar year)
	WW	Week code (week of January 1 is week '01')
	NNN	Alphanumeric traceability code
	(e3)	RoHS Compliant JEDEC designator for Matte Tin (Sn)
	*	This package is RoHS Compliant. The RoHS Compliant JEDEC designator ((e3)) can be found on the outer packaging for this package.

Note: In the event the full Microchip part number cannot be marked on one line, it will be carried over to the next line, thus limiting the number of available characters for customer-specific information.

MCP1643

8-Lead Plastic Dual Flat, No Lead Package (MC) – 2x3x0.9 mm Body [DFN]

Note: For the most current package drawings, please see the Microchip Packaging Specification located at <http://www.microchip.com/packaging>

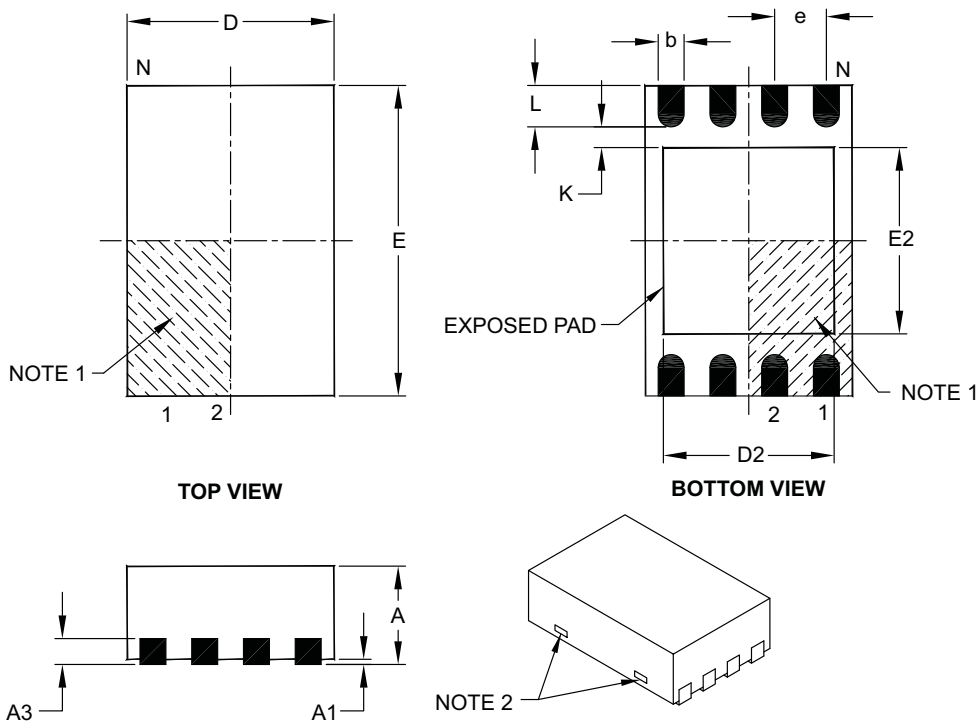

Dimension Limits	Units	MILLIMETERS		
		MIN	NOM	MAX
Number of Pins	N	8		
Pitch	e	0.50 BSC		
Overall Height	A	0.80	0.90	1.00
Standoff	A1	0.00	0.02	0.05
Contact Thickness	A3	0.20 REF		
Overall Length	D	2.00 BSC		
Overall Width	E	3.00 BSC		
Exposed Pad Length	D2	1.30	–	1.55
Exposed Pad Width	E2	1.50	–	1.75
Contact Width	b	0.20	0.25	0.30
Contact Length	L	0.30	0.40	0.50
Contact-to-Exposed Pad	K	0.20	–	–

Notes:

- Pin 1 visual index feature may vary, but must be located within the hatched area.
- Package may have one or more exposed tie bars at ends.
- Package is saw singulated.
- Dimensioning and tolerancing per ASME Y14.5M.
 - BSC: Basic Dimension. Theoretically exact value shown without tolerances.
 - REF: Reference Dimension, usually without tolerance, for information purposes only.

Microchip Technology Drawing C04-123C

8-Lead Plastic Dual Flat, No Lead Package (MC) - 2x3x0.9mm Body [DFN]

Note: For the most current package drawings, please see the Microchip Packaging Specification located at <http://www.microchip.com/packaging>

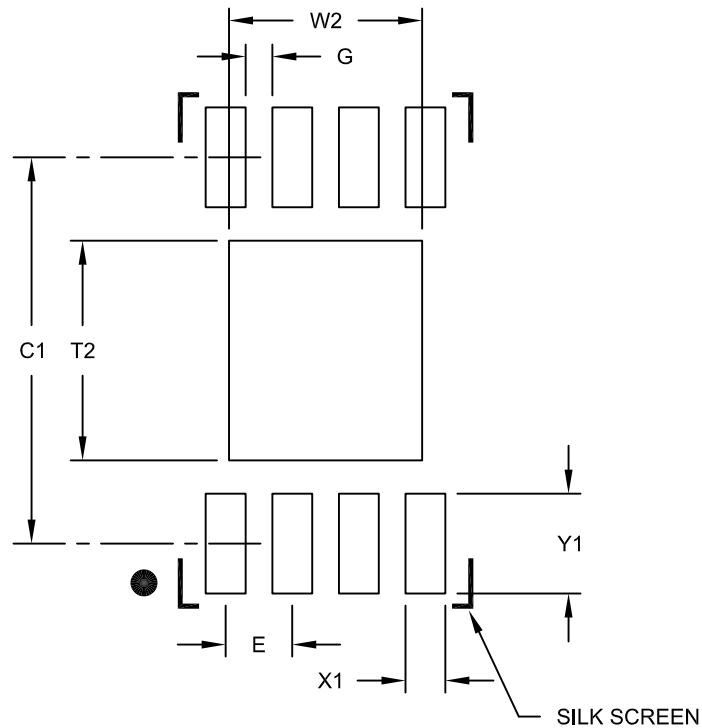

RECOMMENDED LAND PATTERN

Dimension Limits	Units	MILLIMETERS		
		MIN	NOM	MAX
Contact Pitch	E	0.50 BSC		
Optional Center Pad Width	W2			1.45
Optional Center Pad Length	T2			1.75
Contact Pad Spacing	C1		2.90	
Contact Pad Width (X8)	X1			0.30
Contact Pad Length (X8)	Y1			0.75
Distance Between Pads	G	0.20		

Notes:

1. Dimensioning and tolerancing per ASME Y14.5M

BSC: Basic Dimension. Theoretically exact value shown without tolerances.

Microchip Technology Drawing No. C04-2123B

MCP1643

8-Lead Plastic Micro Small Outline Package (MS) [MSOP]

Note: For the most current package drawings, please see the Microchip Packaging Specification located at <http://www.microchip.com/packaging>

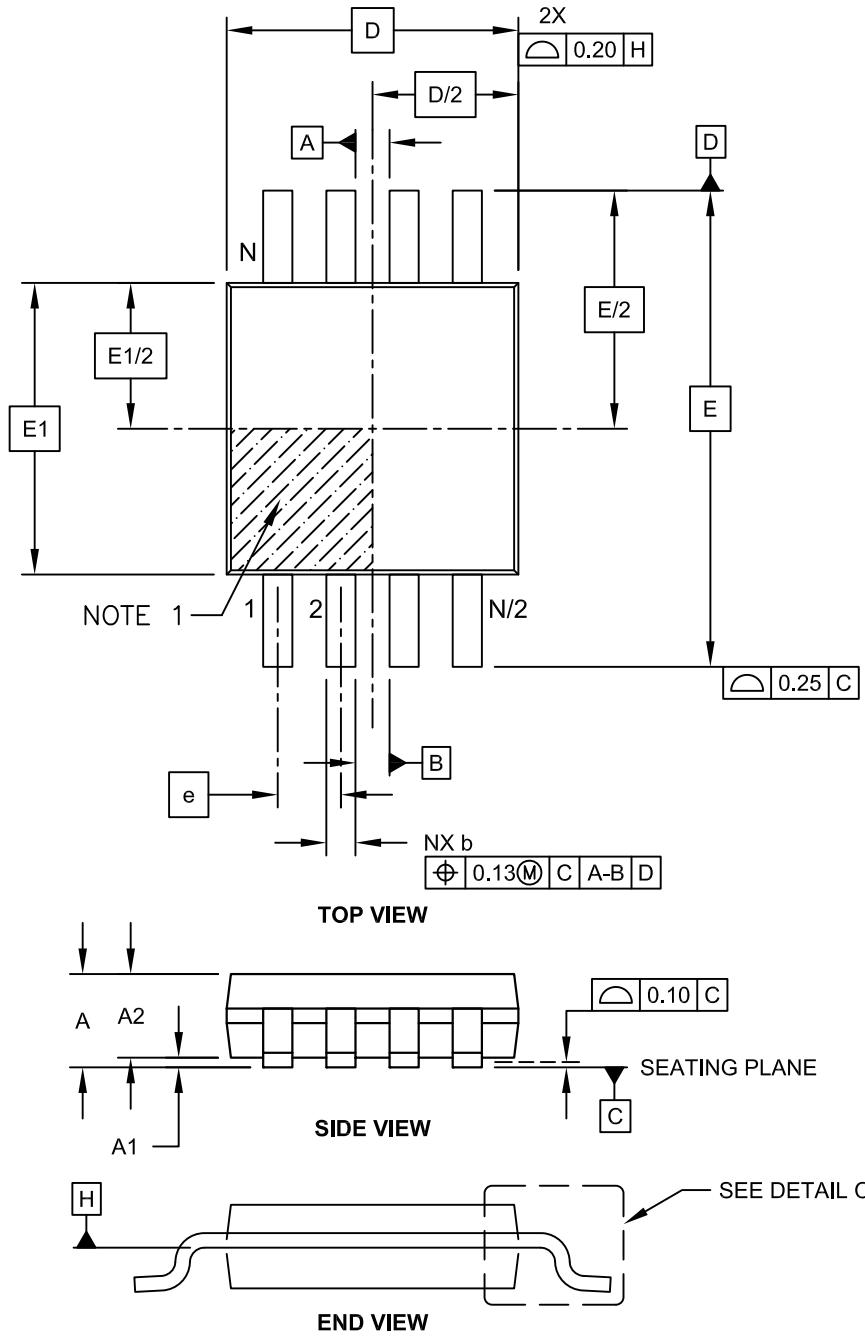

Microchip Technology Drawing C04-111C Sheet 1 of 2

8-Lead Plastic Micro Small Outline Package (MS) [MSOP]

Note: For the most current package drawings, please see the Microchip Packaging Specification located at <http://www.microchip.com/packaging>

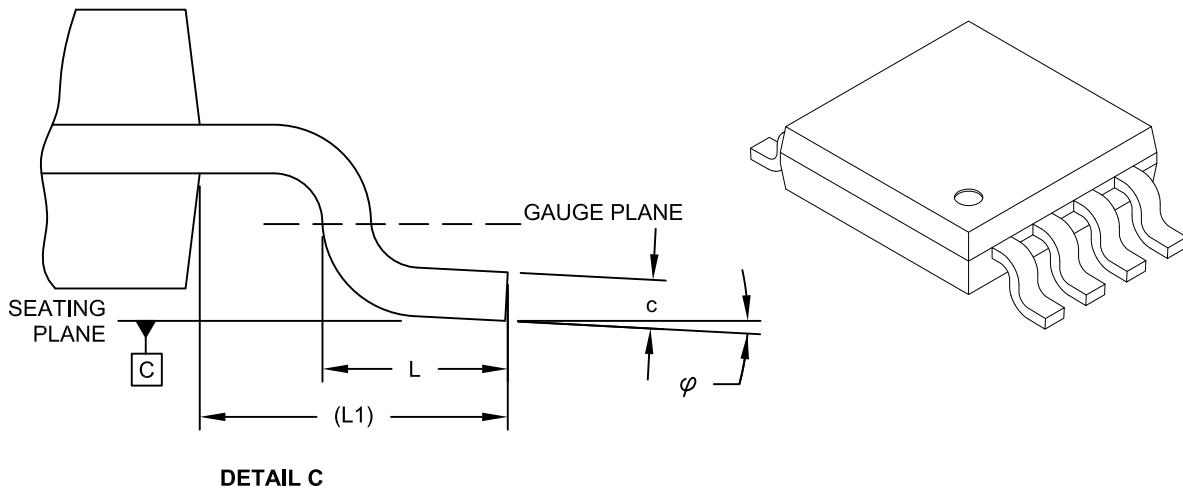

Dimension Limits	Units	MILLIMETERS		
		MIN	NOM	MAX
Number of Pins	N	8		
Pitch	e	0.65 BSC		
Overall Height	A	-	-	1.10
Molded Package Thickness	A2	0.75	0.85	0.95
Standoff	A1	0.00	-	0.15
Overall Width	E	4.90 BSC		
Molded Package Width	E1	3.00 BSC		
Overall Length	D	3.00 BSC		
Foot Length	L	0.40	0.60	0.80
Footprint	L1	0.95 REF		
Foot Angle	φ	0°	-	8°
Lead Thickness	c	0.08	-	0.23
Lead Width	b	0.22	-	0.40

Notes:

- Pin 1 visual index feature may vary, but must be located within the hatched area.
- Dimensions D and E1 do not include mold flash or protrusions. Mold flash or protrusions shall not exceed 0.15mm per side.
- Dimensioning and tolerancing per ASME Y14.5M.
 BSC: Basic Dimension. Theoretically exact value shown without tolerances.
 REF: Reference Dimension, usually without tolerance, for information purposes only.

Microchip Technology Drawing C04-111C Sheet 2 of 2

MCP1643

8-Lead Plastic Micro Small Outline Package (MS) [MSOP]

Note: For the most current package drawings, please see the Microchip Packaging Specification located at <http://www.microchip.com/packaging>

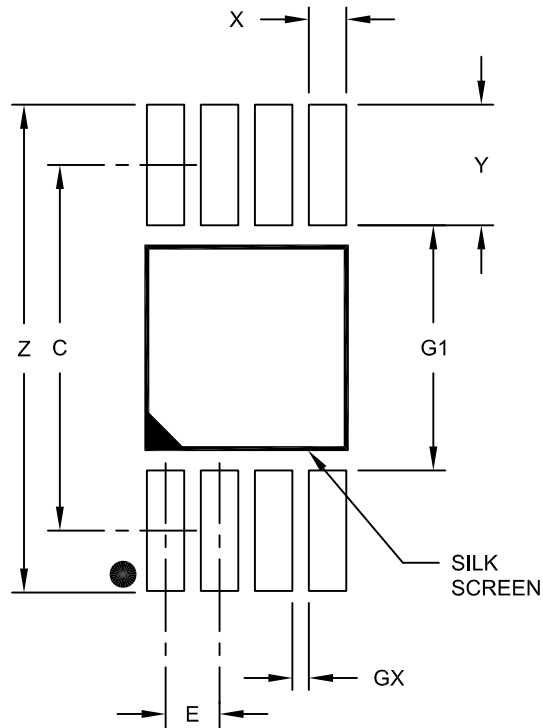

RECOMMENDED LAND PATTERN

Dimension Limits	Units	MILLIMETERS		
		MIN	NOM	MAX
Contact Pitch	E	0.65 BSC		
Contact Pad Spacing	C		4.40	
Overall Width	Z			5.85
Contact Pad Width (X8)	X1			0.45
Contact Pad Length (X8)	Y1			1.45
Distance Between Pads	G1	2.95		
Distance Between Pads	GX	0.20		

Notes:

1. Dimensioning and tolerancing per ASME Y14.5M

BSC: Basic Dimension. Theoretically exact value shown without tolerances.

Microchip Technology Drawing No. C04-2111A

APPENDIX A: REVISION HISTORY

Revision A (August 2013)

- Original Release of this Document.

MCP1643

NOTES:

PRODUCT IDENTIFICATION SYSTEM

To order or obtain information, e.g., on pricing or delivery, refer to the factory or the listed sales office.

<u>PART NO.</u>	<u>X</u>	<u>/XX</u>
Device	Temperature Range	Package
Device: MCP1643: LED Constant Current Regulator MCP1643T: LED Constant Current Regulator (Tape and Reel)	Temperature Range: I = -40°C to +85°C (Industrial)	Package: MC = Plastic Dual Flat, No Lead Package - 2x3x0.9 mm Body (DFN) MS = Plastic Micro Small Outline Package (MSOP)
Examples: a) MCP1643-I/MC: Industrial Temperature, 8LD 2x3 DFN package b) MCP1643T-I/MC: Tape and Reel, Industrial Temperature, 8LD 2x3 DFN package c) MCP1643-I/MS: Industrial Temperature, 8LD MSOP package d) MCP1643T-I/MS: Tape and Reel, Industrial Temperature, 8LD MSOP package		

MCP1643

NOTES:

Note the following details of the code protection feature on Microchip devices:

- Microchip products meet the specification contained in their particular Microchip Data Sheet.
- Microchip believes that its family of products is one of the most secure families of its kind on the market today, when used in the intended manner and under normal conditions.
- There are dishonest and possibly illegal methods used to breach the code protection feature. All of these methods, to our knowledge, require using the Microchip products in a manner outside the operating specifications contained in Microchip's Data Sheets. Most likely, the person doing so is engaged in theft of intellectual property.
- Microchip is willing to work with the customer who is concerned about the integrity of their code.
- Neither Microchip nor any other semiconductor manufacturer can guarantee the security of their code. Code protection does not mean that we are guaranteeing the product as “unbreakable.”

Code protection is constantly evolving. We at Microchip are committed to continuously improving the code protection features of our products. Attempts to break Microchip's code protection feature may be a violation of the Digital Millennium Copyright Act. If such acts allow unauthorized access to your software or other copyrighted work, you may have a right to sue for relief under that Act.

Information contained in this publication regarding device applications and the like is provided only for your convenience and may be superseded by updates. It is your responsibility to ensure that your application meets with your specifications. MICROCHIP MAKES NO REPRESENTATIONS OR WARRANTIES OF ANY KIND WHETHER EXPRESS OR IMPLIED, WRITTEN OR ORAL, STATUTORY OR OTHERWISE, RELATED TO THE INFORMATION, INCLUDING BUT NOT LIMITED TO ITS CONDITION, QUALITY, PERFORMANCE, MERCHANTABILITY OR FITNESS FOR PURPOSE. Microchip disclaims all liability arising from this information and its use. Use of Microchip devices in life support and/or safety applications is entirely at the buyer's risk, and the buyer agrees to defend, indemnify and hold harmless Microchip from any and all damages, claims, suits, or expenses resulting from such use. No licenses are conveyed, implicitly or otherwise, under any Microchip intellectual property rights.

Trademarks

The Microchip name and logo, the Microchip logo, dsPIC, FlashFlex, KEELOQ, KEELOQ logo, MPLAB, PIC, PICmicro, PICSTART, PIC³² logo, rPIC, SST, SST Logo, SuperFlash and UNI/O are registered trademarks of Microchip Technology Incorporated in the U.S.A. and other countries.

FilterLab, Hampshire, HI-TECH C, Linear Active Thermistor, MTP, SEEVAL and The Embedded Control Solutions Company are registered trademarks of Microchip Technology Incorporated in the U.S.A.

Silicon Storage Technology is a registered trademark of Microchip Technology Inc. in other countries.

Analog-for-the-Digital Age, Application Maestro, BodyCom, chipKIT, chipKIT logo, CodeGuard, dsPICDEM, dsPICDEM.net, dsPICworks, dsSPEAK, ECAN, ECONOMONITOR, FanSense, HI-TIDE, In-Circuit Serial Programming, ICSP, Mindi, MiWi, MPASM, MPF, MPLAB Certified logo, MPLIB, MPLINK, mTouch, Omniclient Code Generation, PICC, PICC-18, PICDEM, PICDEM.net, PICkit, PICtail, REAL ICE, rLAB, Select Mode, SQI, Serial Quad I/O, Total Endurance, TSHARC, UniWinDriver, WiperLock, ZENA and Z-Scale are trademarks of Microchip Technology Incorporated in the U.S.A. and other countries.

SQTP is a service mark of Microchip Technology Incorporated in the U.S.A.

GestIC and ULPP are registered trademarks of Microchip Technology Germany II GmbH & Co. KG, a subsidiary of Microchip Technology Inc., in other countries.

All other trademarks mentioned herein are property of their respective companies.

© 2013, Microchip Technology Incorporated, Printed in the U.S.A., All Rights Reserved.

 Printed on recycled paper.

ISBN: 978-1-62077-402-1

Microchip received ISO/TS-16949:2009 certification for its worldwide headquarters, design and wafer fabrication facilities in Chandler and Tempe, Arizona; Gresham, Oregon and design centers in California and India. The Company's quality system processes and procedures are for its PIC[®] MCUs and dsPIC[®] DSCs, KEELOQ[®] code hopping devices, Serial EEPROMs, microperipherals, nonvolatile memory and analog products. In addition, Microchip's quality system for the design and manufacture of development systems is ISO 9001:2000 certified.

QUALITY MANAGEMENT SYSTEM
CERTIFIED BY DNV
== ISO/TS 16949 ==



MICROCHIP

Worldwide Sales and Service

AMERICAS

Corporate Office
2355 West Chandler Blvd.
Chandler, AZ 85224-6199
Tel: 480-792-7200
Fax: 480-792-7277
Technical Support:
<http://www.microchip.com/support>
Web Address:
www.microchip.com

Atlanta
Duluth, GA
Tel: 678-957-9614
Fax: 678-957-1455

Boston
Westborough, MA
Tel: 774-760-0087
Fax: 774-760-0088

Chicago
Itasca, IL
Tel: 630-285-0071
Fax: 630-285-0075

Cleveland
Independence, OH
Tel: 216-447-0464
Fax: 216-447-0643

Dallas
Addison, TX
Tel: 972-818-7423
Fax: 972-818-2924

Detroit
Farmington Hills, MI
Tel: 248-538-2250
Fax: 248-538-2260

Indianapolis
Noblesville, IN
Tel: 317-773-8323
Fax: 317-773-5453

Los Angeles
Mission Viejo, CA
Tel: 949-462-9523
Fax: 949-462-9608

Santa Clara
Santa Clara, CA
Tel: 408-961-6444
Fax: 408-961-6445

Toronto
Mississauga, Ontario,
Canada
Tel: 905-673-0699
Fax: 905-673-6509

ASIA/PACIFIC

Asia Pacific Office
Suites 3707-14, 37th Floor
Tower 6, The Gateway
Harbour City, Kowloon
Hong Kong
Tel: 852-2401-1200
Fax: 852-2401-3431

Australia - Sydney
Tel: 61-2-9868-6733
Fax: 61-2-9868-6755

China - Beijing
Tel: 86-10-8569-7000
Fax: 86-10-8528-2104

China - Chengdu
Tel: 86-28-8665-5511
Fax: 86-28-8665-7889

China - Chongqing
Tel: 86-23-8980-9588
Fax: 86-23-8980-9500

China - Hangzhou
Tel: 86-571-2819-3187
Fax: 86-571-2819-3189

China - Hong Kong SAR
Tel: 852-2943-5100
Fax: 852-2401-3431

China - Nanjing
Tel: 86-25-8473-2460
Fax: 86-25-8473-2470

China - Qingdao
Tel: 86-532-8502-7355
Fax: 86-532-8502-7205

China - Shanghai
Tel: 86-21-5407-5533
Fax: 86-21-5407-5066

China - Shenyang
Tel: 86-24-2334-2829
Fax: 86-24-2334-2393

China - Shenzhen
Tel: 86-755-8864-2200
Fax: 86-755-8203-1760

China - Wuhan
Tel: 86-27-5980-5300
Fax: 86-27-5980-5118

China - Xian
Tel: 86-29-8833-7252
Fax: 86-29-8833-7256

China - Xiamen
Tel: 86-592-2388138
Fax: 86-592-2388130

China - Zhuhai
Tel: 86-756-3210040
Fax: 86-756-3210049

ASIA/PACIFIC

India - Bangalore
Tel: 91-80-3090-4444
Fax: 91-80-3090-4123

India - New Delhi
Tel: 91-11-4160-8631
Fax: 91-11-4160-8632

India - Pune
Tel: 91-20-2566-1512
Fax: 91-20-2566-1513

Japan - Osaka
Tel: 81-6-6152-7160
Fax: 81-6-6152-9310

Japan - Tokyo
Tel: 81-3-6880-3770
Fax: 81-3-6880-3771

Korea - Daegu
Tel: 82-53-744-4301
Fax: 82-53-744-4302

Korea - Seoul
Tel: 82-2-554-7200
Fax: 82-2-558-5932 or
82-2-558-5934

Malaysia - Kuala Lumpur
Tel: 60-3-6201-9857
Fax: 60-3-6201-9859

Malaysia - Penang
Tel: 60-4-227-8870
Fax: 60-4-227-4068

Philippines - Manila
Tel: 63-2-634-9065
Fax: 63-2-634-9069

Singapore
Tel: 65-6334-8870
Fax: 65-6334-8850

Taiwan - Hsin Chu
Tel: 886-3-5778-366
Fax: 886-3-5770-955

Taiwan - Kaohsiung
Tel: 886-7-213-7828
Fax: 886-7-330-9305

Taiwan - Taipei
Tel: 886-2-2508-8600
Fax: 886-2-2508-0102

Thailand - Bangkok
Tel: 66-2-694-1351
Fax: 66-2-694-1350

EUROPE

Austria - Wels
Tel: 43-7242-2244-39
Fax: 43-7242-2244-393

Denmark - Copenhagen
Tel: 45-4450-2828
Fax: 45-4485-2829

France - Paris
Tel: 33-1-69-53-63-20
Fax: 33-1-69-30-90-79

Germany - Munich
Tel: 49-89-627-144-0
Fax: 49-89-627-144-44

Italy - Milan
Tel: 39-0331-742611
Fax: 39-0331-466781

Netherlands - Drunen
Tel: 31-416-690399
Fax: 31-416-690340

Spain - Madrid
Tel: 34-91-708-08-90
Fax: 34-91-708-08-91

UK - Wokingham
Tel: 44-118-921-5869
Fax: 44-118-921-5820

11/29/12

Looking for pricing, stock, or lifecycle information?

Click below to explore more details on WIN SOURCE:

 [View MCP1643T-I/MC on WIN SOURCE](#)

 [Microchip Technology](#) Information

Optimize Your Supply Chain with WIN SOURCE Solutions

-  Global Sourcing Solution
-  Obsolete Management
-  Cost Control Management
-  Shortage Management
-  Alternative Solution
-  Excess Inventory Management