



**THE DATASHEET OF
INA293A2QDBVRQ1**



INA293-Q1, AEC-Q100, –4 V to 110 V, 1.3-MHz, Ultra-Precise Current Sense Amplifier

1 Features

- AEC-Q100 qualified for automotive applications
 - Temperature grade 1: –40 °C to +125 °C, T_A
- [Functional Safety-Capable](#)
 - [Documentation available to aid functional safety system design](#)
- Wide common-mode voltage:
 - Operational voltage: –4 V to +110 V
 - Survival voltage: –20 V to +120 V
- Excellent CMRR:
 - 160-dB DC-CMRR
 - 85-dB AC-CMRR at 50 kHz
- Accuracy:
 - Gain:
 - Gain error: ±0.15% (maximum)
 - Gain drift: ±10 ppm/ °C (maximum)
 - Offset:
 - Offset voltage: ±15 μV (typical)
 - Offset drift: ±0.05 μV/ °C (typical)
- Available gains:
 - INA293A1-Q1, INA293B1-Q1 : 20 V/V
 - INA293A2-Q1, INA293B2-Q1 : 50 V/V
 - INA293A3-Q1, INA293B3-Q1 : 100 V/V
 - INA293A4-Q1, INA293B4-Q1 : 200 V/V
 - INA293A5-Q1, INA293B5-Q1 : 500 V/V
- High bandwidth: 1.3 MHz
- Slew rate: 2.5 V/μs
- Quiescent current: 1.5 mA

2 Applications

- [48-V automotive](#)
- [Solenoid control](#)
- [48-V DC/DC converter](#)
- [Valve control](#)

3 Description

The INA293-Q1 is a ultra-precise current sense amplifier that can measure voltage drops across shunt resistors over a wide common-mode range from –4 V to 110 V. The negative common-mode voltage allows the device to operate below ground, thus accommodating precise measurement of recirculating currents in half-bridge applications. The combination of a low offset voltage, small gain error and high DC CMRR enables highly accurate current measurement. The INA293-Q1 is not only designed for DC current measurement, but also for high-speed applications (ex. Fast over-current protection) with a high bandwidth of 1.3 MHz and an 85-dB AC CMRR (at 50 kHz).

The INA293-Q1 operates from a single 2.7-V to 20-V supply, drawing 1.5 mA of supply current. The INA293-Q1 is available with five gain options: 20 V/V, 50 V/V, 100 V/V, 200 V/V, and 500 V/V. These gain options address wide dynamic range current-sensing applications.

The INA293-Q1 is specified over an operating temperature range of –40 °C to +125 °C and is offered in a space-saving SOT-23 package with two pin-out variants.

Device Information⁽¹⁾

PART NUMBER	PACKAGE	BODY SIZE (NOM)
INA293-Q1	SOT-23 (5)	2.90 mm × 1.60 mm

- (1) For all available packages, see the package option addendum at the end of the data sheet.

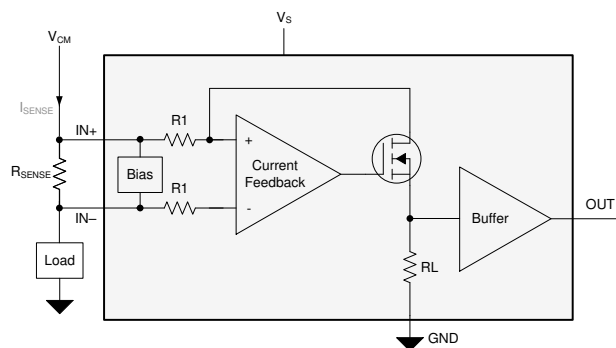

Functional Block Diagram



Table of Contents

1 Features	1	7.4 Device Functional Modes.....	15
2 Applications	1	8 Application and Implementation	16
3 Description	1	8.1 Application Information.....	16
4 Revision History	2	8.2 Typical Application.....	18
5 Pin Configuration and Functions	3	8.3 Power Supply Recommendations.....	19
6 Specifications	4	8.4 Layout.....	19
6.1 Absolute Maximum Ratings	4	9 Device and Documentation Support	21
6.2 ESD Ratings	4	9.1 Documentation Support.....	21
6.3 Recommended Operating Conditions	5	9.2 Receiving Notification of Documentation Updates....	21
6.4 Thermal Information	5	9.3 Support Resources.....	21
6.5 Electrical Characteristics	5	9.4 Trademarks.....	21
6.6 Typical Characteristics.....	7	9.5 Electrostatic Discharge Caution.....	21
7 Detailed Description	13	9.6 Glossary.....	21
7.1 Overview.....	13	10 Mechanical, Packaging, and Orderable	
7.2 Functional Block Diagram.....	13	Information	21
7.3 Feature Description.....	13		

4 Revision History

Changes from Revision B (June 2021) to Revision C (August 2022)	Page
• Changed Equation 5	17
• Moved the <i>Power Supply Recommendations</i> and <i>Layout</i> sections to the <i>Application and Implementation</i> section.....	19

Changes from Revision A (September 2020) to Revision B (June 2021)	Page
• Changed data sheet title from: INA293-Q1, AEC-Q100, –4-V to 110-V, 1-MHz, High-Precision Current Sense Amplifier to: INA293-Q1, AEC-Q100, –4-V to 110-V, 1.3-MHz, High-Precision Current Sense Amplifier.....	1

Changes from Revision * (May 2019) to Revision A (September 2020)	Page
• Changed data sheet title.....	1
• Changed data sheet status from Advanced Information to Production Data.....	1
• Updated the numbering format for tables, figures, and cross-references throughout the document.....	1
• Added functional safety-capable bullets to the <i>Features</i> section.....	1
• Changed 'high-precise' to 'ultra-precise' in <i>Description</i> section.....	1

5 Pin Configuration and Functions

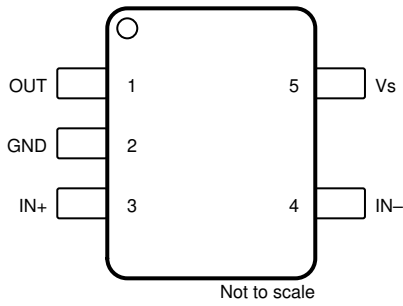

Figure 5-1. INA293A-Q1: DBV Package 5-Pin SOT-23 Top View

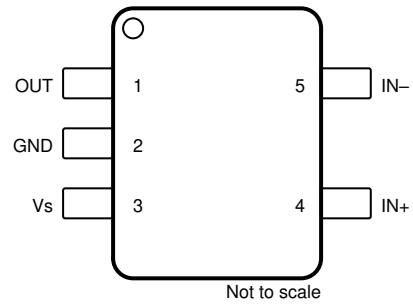

Figure 5-2. INA293B-Q1: DBV Package 5-Pin SOT-23 Top View

Table 5-1. Pin Functions

NAME	PIN		TYPE	DESCRIPTION
	INA293A-Q1	INA293B-Q1		
GND	2	2	Ground	Ground
OUT	1	1	Output	Output voltage
Vs	5	3	Power	Power supply
IN+	3	4	Input	Shunt resistor positive sense input
IN-	4	5	Input	Shunt resistor negative sense input

6 Specifications

6.1 Absolute Maximum Ratings

over operating free-air temperature range (unless otherwise noted)⁽¹⁾

		MIN	MAX	UNIT
Supply Voltage (V _s)		-0.3	22	V
Analog Inputs, V _{IN+} , V _{IN-} ⁽²⁾	Differential (V _{IN+}) – (V _{IN-}), INA293A5-Q1, INA293B5-Q1	-6	6	V
	Differential (V _{IN+}) – (V _{IN-}), All others	-12	12	
	Common - mode	-20	120	
Output		GND – 0.3	V _s + 0.3	V
T _A	Operating temperature	-55	150	°C
T _J	Junction temperature		150	°C
T _{stg}	Storage temperature	-65	150	°C

- (1) Stresses beyond those listed under *Absolute Maximum Rating* may cause permanent damage to the device. These are stress ratings only, which do not imply functional operation of the device at these or any other conditions beyond those indicated under *Recommended Operating Condition*. Exposure to absolute-maximum-rated conditions for extended periods may affect device reliability.
- (2) V_{IN+} and V_{IN-} are the voltages at the IN+ and IN– pins, respectively.

6.2 ESD Ratings

			VALUE	UNIT
V _(ESD)	Electrostatic discharge	Human body model (HBM), per AEC Q100-002, all pins ⁽¹⁾ HBM ESD Classification Level 2	±2000	V
		Charged device model (CDM), per AEC Q100-011, all pins CDM ESD Classification Level C6	±1000	

- (1) AEC Q100-002 indicates that HBM stressing shall be in accordance with the ANSI/ESDA/JEDEC JS-001 specification

6.3 Recommended Operating Conditions

over operating free-air temperature range (unless otherwise noted)

		MIN	NOM	MAX	UNIT
V_{CM}	Common-mode input range	-4	48	110	V
V_S	Operating supply range	2.7	5	20	V
V_{SENSE}	Differential sense input range	0		V_S / G	V
T_A	Ambient temperature	-40		125	°C

6.4 Thermal Information

THERMAL METRIC ⁽¹⁾		INA293-Q1	UNIT
		DBV (SOT-23)	
		5 PINS	
$R_{\theta JA}$	Junction-to-ambient thermal resistance	184.7	°C/W
$R_{\theta JC(top)}$	Junction-to-case (top) thermal resistance	105.6	°C/W
$R_{\theta JB}$	Junction-to-board thermal resistance	47.2	°C/W
Ψ_{JT}	Junction-to-top characterization parameter	21.5	°C/W
Ψ_{JB}	Junction-to-board characterization parameter	46.9	°C/W
$R_{\theta JC(bot)}$	Junction-to-case (bottom) thermal resistance	N/A	°C/W

(1) For more information about traditional and new thermal metrics, see the [Semiconductor and IC Package Thermal Metrics](#) application report.

6.5 Electrical Characteristics

at $T_A = 25^\circ\text{C}$, $V_S = 5\text{ V}$, $V_{SENSE} = V_{IN+} - V_{IN-} = 0.5\text{ V} / \text{Gain}$, $V_{CM} = V_{IN-} = 48\text{ V}$ (unless otherwise noted)

PARAMETER		TEST CONDITIONS	MIN	TYP	MAX	UNIT
INPUT						
V_{CM}	Common-mode input range ⁽¹⁾	$T_A = -40^\circ\text{C}$ to $+125^\circ\text{C}$	-4		110	V
CMRR	Common-mode rejection ratio, input referred	$-4\text{ V} \leq V_{CM} \leq 110\text{ V}$, $T_A = -40^\circ\text{C}$ to $+125^\circ\text{C}$	140	160		dB
		$f = 50\text{ kHz}$		85		dB
V_{os}	Offset voltage, input referred	INA293x1-Q1		± 30	± 150	μV
		INA293x2-Q1		± 15	± 80	
		INA293x3-Q1		± 10	± 50	
		INA293x4-Q1		± 5	± 30	
		INA293x5-Q1		± 2	± 20	
dV_{os}/dT	Offset voltage drift	$T_A = -40^\circ\text{C}$ to $+125^\circ\text{C}$, INA293x1-Q1, INA293x2-Q1, INA293x3-Q1		± 0.05	± 0.5	$\mu\text{V}/^\circ\text{C}$
		$T_A = -40^\circ\text{C}$ to $+125^\circ\text{C}$, INA293x4-Q1, INA293x5-Q1		± 0.025	± 0.25	
PSRR	Power supply rejection ratio, input referred	INA293x1-Q1, $2.7\text{ V} \leq V_S \leq 20\text{ V}$, $T_A = -40^\circ\text{C}$ to $+125^\circ\text{C}$		± 1	± 8	$\mu\text{V}/\text{V}$
		INA293x2-Q1, INA293x3-Q1, $2.7\text{ V} \leq V_S \leq 20\text{ V}$, $T_A = -40^\circ\text{C}$ to $+125^\circ\text{C}$		± 0.3	± 3	
		INA293x4-Q1, INA293x5-Q1, $2.7\text{ V} \leq V_S \leq 20\text{ V}$, $T_A = -40^\circ\text{C}$ to $+125^\circ\text{C}$		± 0.1	± 1	
I_B	Input bias current	I_{B+} , $V_{SENSE} = 0\text{ V}$	10	20	30	μA
		I_{B-} , $V_{SENSE} = 0\text{ V}$	10	20	30	μA

6.5 Electrical Characteristics (continued)

at $T_A = 25\text{ }^\circ\text{C}$, $V_S = 5\text{ V}$, $V_{SENSE} = V_{IN+} - V_{IN-} = 0.5\text{ V} / \text{Gain}$, $V_{CM} = V_{IN-} = 48\text{ V}$ (unless otherwise noted)

PARAMETER		TEST CONDITIONS	MIN	TYP	MAX	UNIT
OUTPUT						
G	Gain	INA293x1-Q1		20		V/V
		INA293x2-Q1		50		V/V
		INA293x3-Q1		100		V/V
		INA293x4-Q1		200		V/V
		INA293x5-Q1		500		V/V
G _{ERR}	Gain error	$GND + 50\text{ mV} \leq V_{OUT} \leq V_S - 200\text{ mV}$		±0.02	±0.15	%
		$T_A = -40\text{ }^\circ\text{C}$ to $+125\text{ }^\circ\text{C}$		±1	±10	ppm/°C
NL _{ERR}	Nonlinearity error			0.01		%
	Maximum capacitive load	No sustained oscillations, no isolation resistor		500		pF
VOLTAGE OUTPUT						
	Swing to V_S (Power supply rail)	$R_{LOAD} = 10\text{ k}\Omega$, $T_A = -40\text{ }^\circ\text{C}$ to $+125\text{ }^\circ\text{C}$		$V_S - 0.07$	$V_S - 0.15$	V
	Swing to ground	$R_{LOAD} = 10\text{ k}\Omega$, $V_{SENSE} = 0\text{ V}$, $T_A = -40\text{ }^\circ\text{C}$ to $+125\text{ }^\circ\text{C}$		0.005	0.02	V
FREQUENCY RESPONSE						
BW	Bandwidth	INA293x1-Q1, $C_{LOAD} = 5\text{ pF}$, $V_{SENSE} = 200\text{ mV}$		1300		kHz
		INA293x2-Q1, $C_{LOAD} = 5\text{ pF}$, $V_{SENSE} = 80\text{ mV}$		1300		
		INA293x3-Q1, $C_{LOAD} = 5\text{ pF}$, $V_{SENSE} = 40\text{ mV}$		1000		
		INA293x4-Q1, $C_{LOAD} = 5\text{ pF}$, $V_{SENSE} = 20\text{ mV}$		900		
		INA293x5-Q1, $C_{LOAD} = 5\text{ pF}$, $V_{SENSE} = 8\text{ mV}$		900		
SR	Slew rate	Rising edge		2.5		V/ μs
	Settling time	$V_{OUT} = 4\text{ V} \pm 0.1\text{ V}$ step, Output settles to 0.5%		10		μs
		$V_{OUT} = 4\text{ V} \pm 0.1\text{ V}$ step, Output settles to 1%		5		
		$V_{OUT} = 4\text{ V} \pm 0.1\text{ V}$ step, Output settles to 5%		1		
NOISE						
V _{en}	Voltage noise density			50		nV/ $\sqrt{\text{Hz}}$
POWER SUPPLY						
V _S	Supply voltage	$T_A = -40\text{ }^\circ\text{C}$ to $+125\text{ }^\circ\text{C}$	2.7		20	V
I _Q	Quiescent current			1.5	2	mA
		$T_A = -40\text{ }^\circ\text{C}$ to $+125\text{ }^\circ\text{C}$			2.25	

(1) Common-mode voltage at both V_{IN+} and V_{IN-} must not exceed the specified common-mode input range.

6.6 Typical Characteristics

All specifications at $T_A = 25\text{ }^\circ\text{C}$, $V_S = 5\text{ V}$, $V_{SENSE} = V_{IN+} - V_{IN-} = 0.5\text{ V} / \text{Gain}$, $V_{CM} = V_{IN-} = 48\text{ V}$, unless otherwise noted.

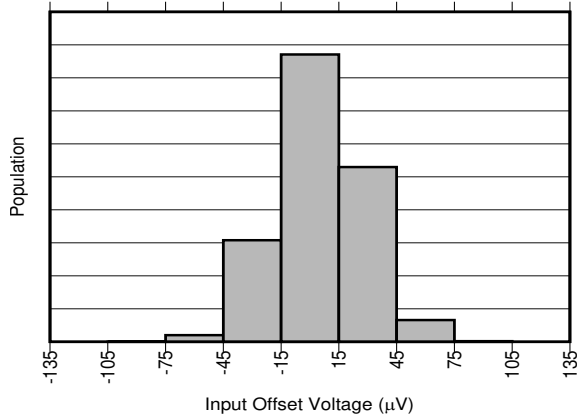

Figure 6-1. INA293x1 Input Offset Production Distribution

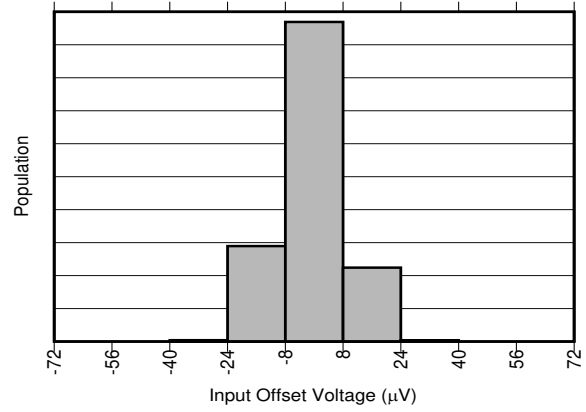

Figure 6-2. INA293x2 Input Offset Production Distribution

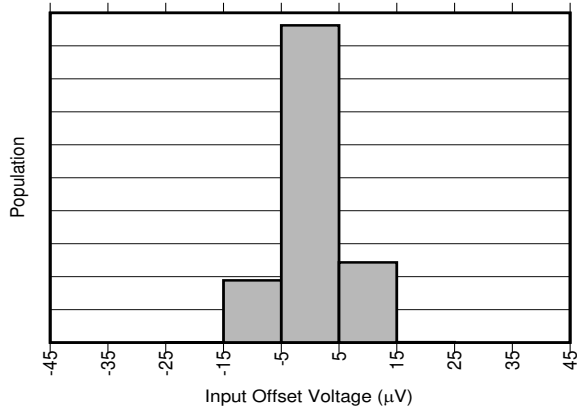

Figure 6-3. INA293x3 Input Offset Production Distribution

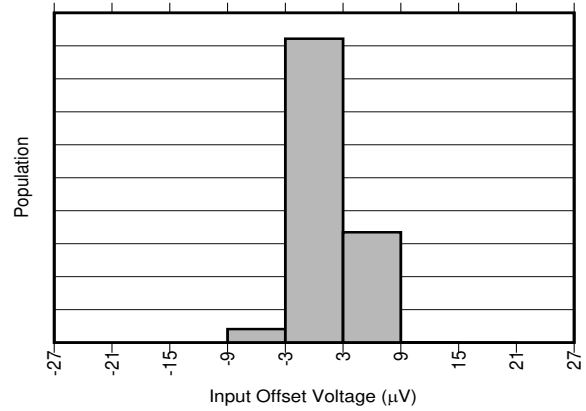

Figure 6-4. INA293x4 Input Offset Production Distribution

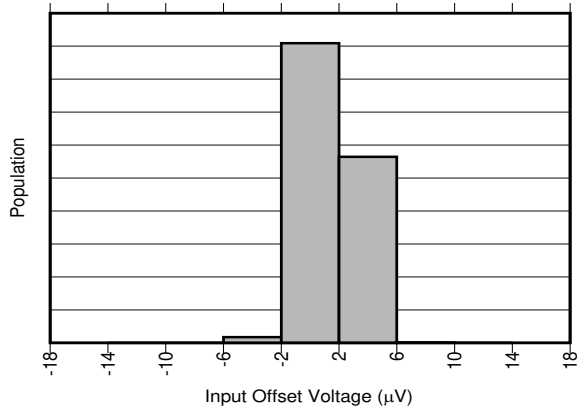

Figure 6-5. INA293x5 Input Offset Production Distribution

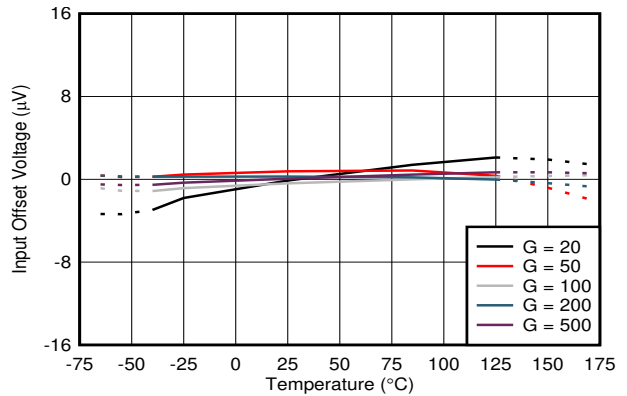

Figure 6-6. Input Offset Voltage vs Temperature

6.6 Typical Characteristics (continued)

All specifications at $T_A = 25\text{ }^\circ\text{C}$, $V_S = 5\text{ V}$, $V_{SENSE} = V_{IN+} - V_{IN-} = 0.5\text{ V} / \text{Gain}$, $V_{CM} = V_{IN-} = 48\text{ V}$, unless otherwise noted.

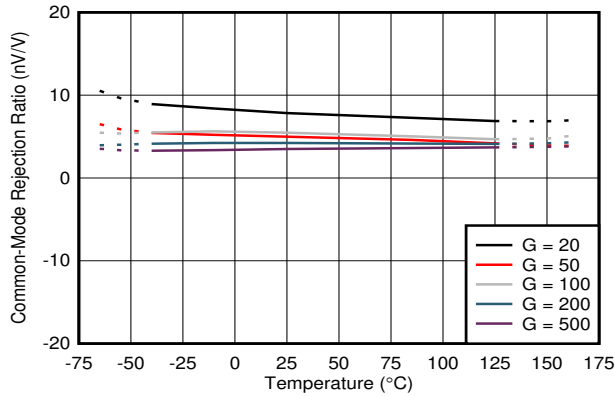

Figure 6-7. Common-Mode Rejection Ratio vs Temperature

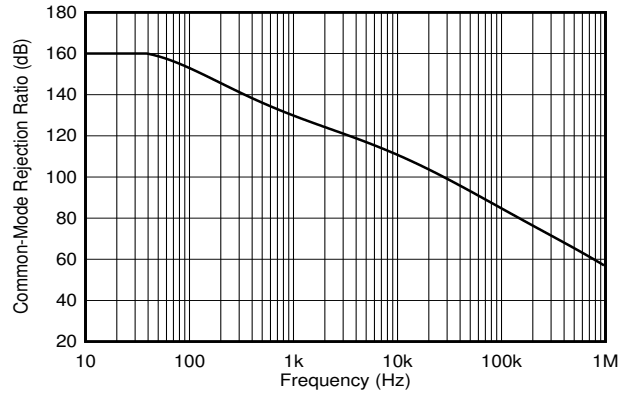

Figure 6-8. Common-Mode Rejection Ratio vs Frequency

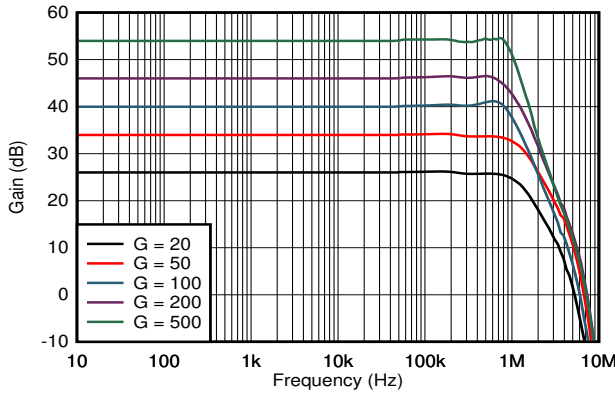

Figure 6-9. Gain vs Frequency

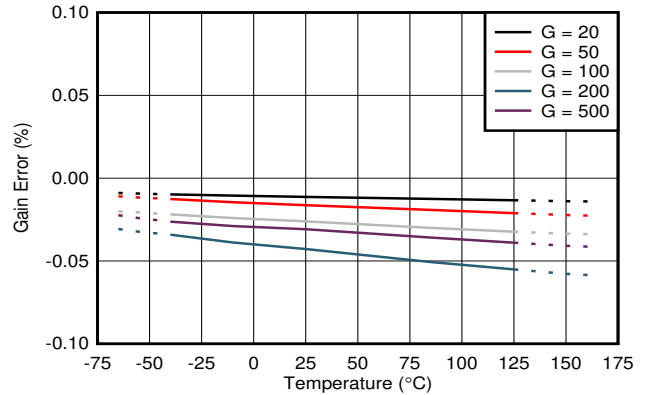

Figure 6-10. Gain Error vs Temperature

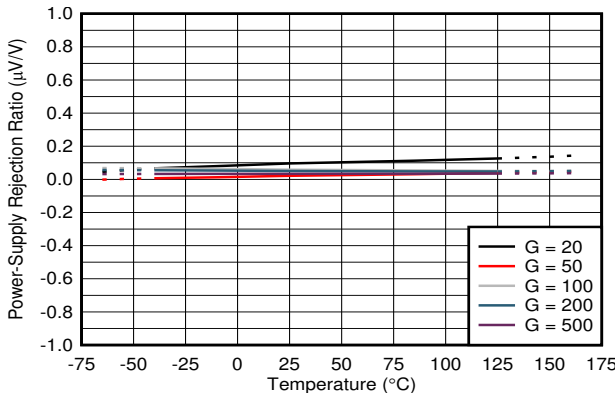

Figure 6-11. Power-Supply Rejection Ratio vs Temperature

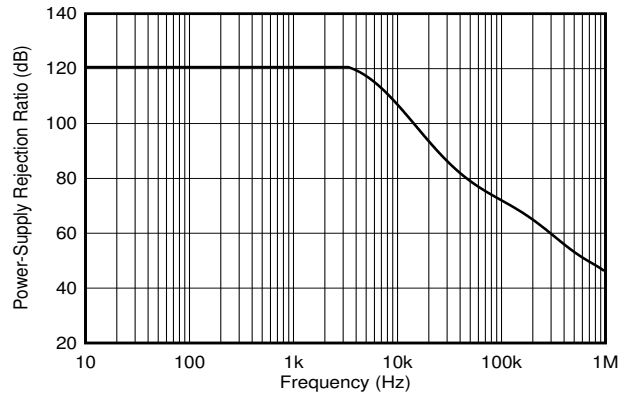

Figure 6-12. Power-Supply Rejection Ratio vs Frequency

6.6 Typical Characteristics (continued)

All specifications at $T_A = 25^\circ\text{C}$, $V_S = 5\text{ V}$, $V_{\text{SENSE}} = V_{\text{IN}+} - V_{\text{IN}-} = 0.5\text{ V / Gain}$, $V_{\text{CM}} = V_{\text{IN}-} = 48\text{ V}$, unless otherwise noted.

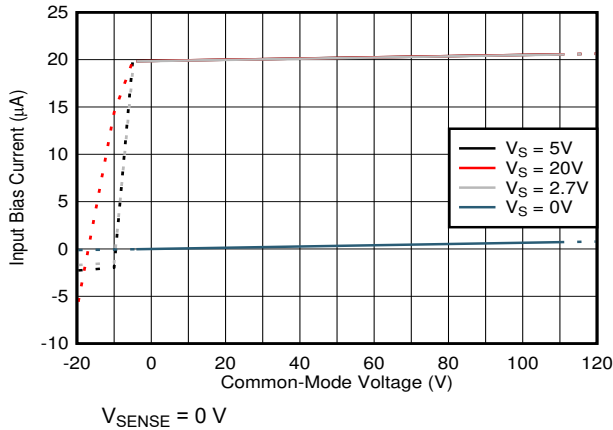

Figure 6-13. Input Bias Current vs Common-Mode Voltage

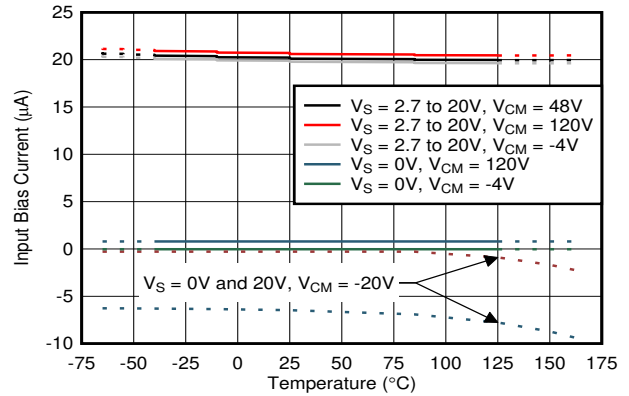

Figure 6-14. Input Bias Current vs Temperature

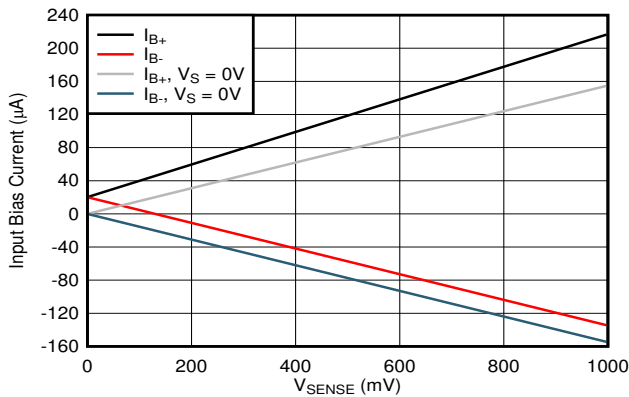

Figure 6-15. INA293x1Q Input Bias Current vs V_{SENSE}

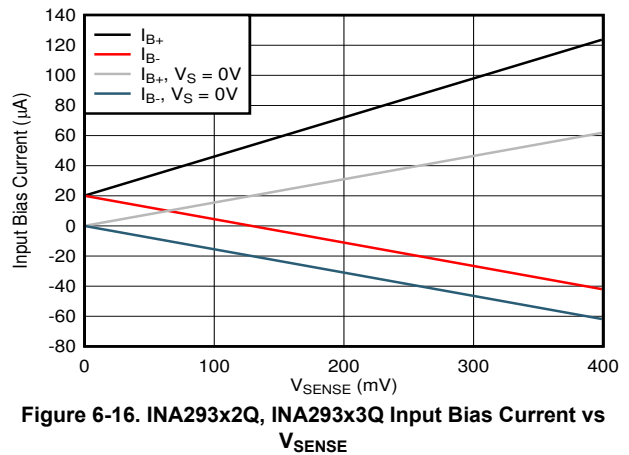

Figure 6-16. INA293x2Q, INA293x3Q Input Bias Current vs V_{SENSE}

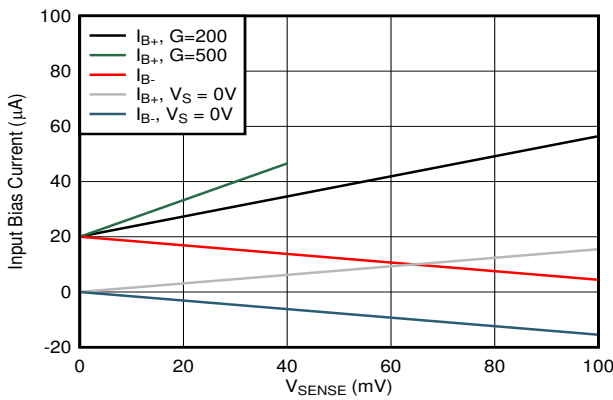

Figure 6-17. INA293x4Q, INA293x5Q Input Bias Current vs V_{SENSE}

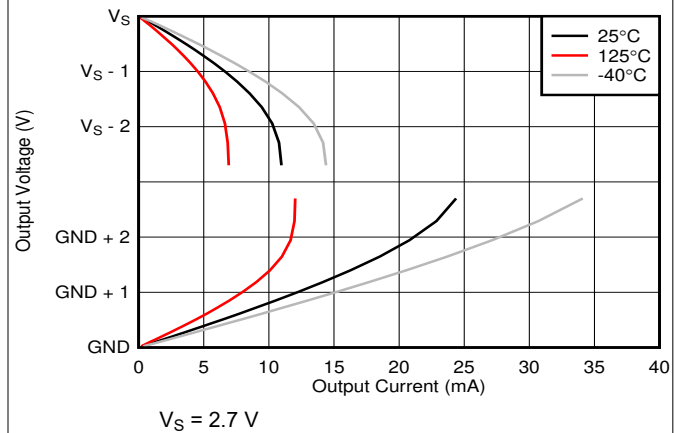

Figure 6-18. Output Voltage vs Output Current

6.6 Typical Characteristics (continued)

All specifications at $T_A = 25^\circ\text{C}$, $V_S = 5\text{ V}$, $V_{\text{SENSE}} = V_{\text{IN}+} - V_{\text{IN}-} = 0.5\text{ V} / \text{Gain}$, $V_{\text{CM}} = V_{\text{IN}-} = 48\text{ V}$, unless otherwise noted.

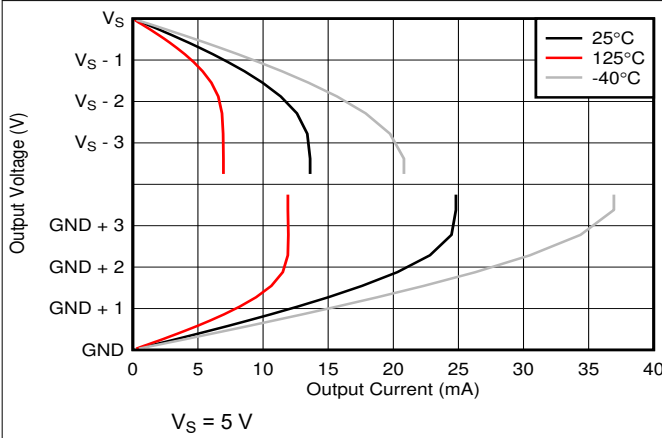

Figure 6-19. Output Voltage vs Output Current

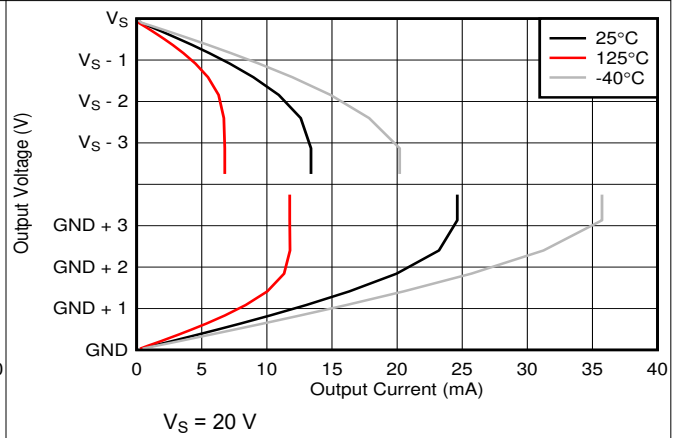

Figure 6-20. Output Voltage vs Output Current

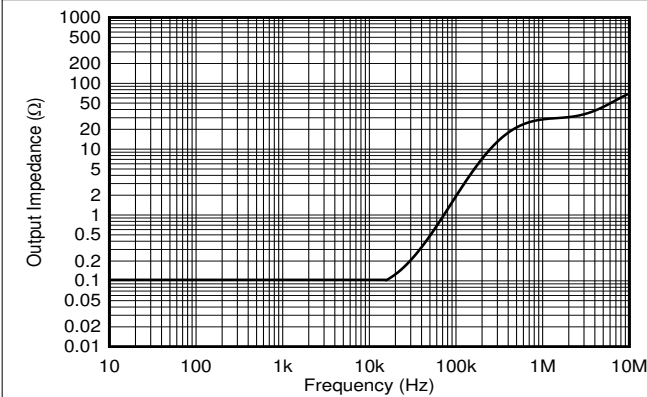

Figure 6-21. Output Impedance vs Frequency

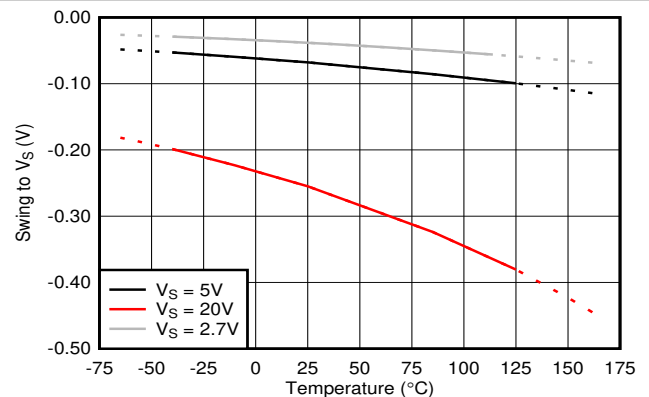

Figure 6-22. Swing to Supply vs Temperature

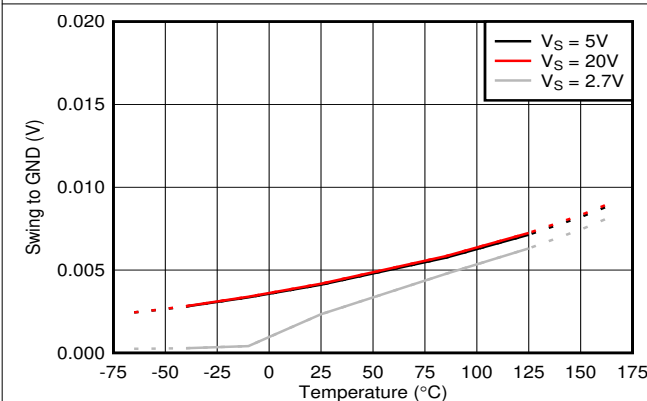

Figure 6-23. Swing to GND vs Temperature

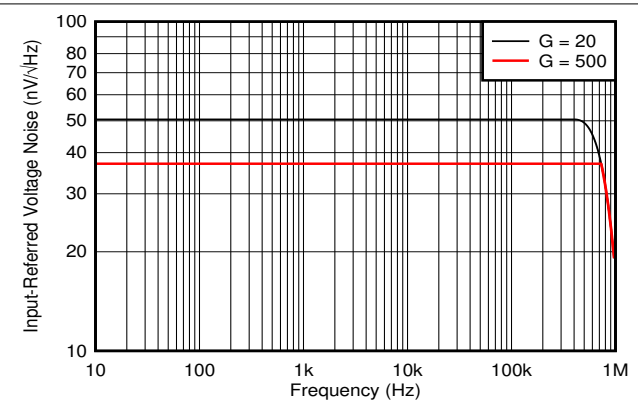

Figure 6-24. Input Referred Noise vs Frequency

6.6 Typical Characteristics (continued)

All specifications at $T_A = 25^\circ\text{C}$, $V_S = 5\text{ V}$, $V_{\text{SENSE}} = V_{\text{IN}+} - V_{\text{IN}-} = 0.5\text{ V / Gain}$, $V_{\text{CM}} = V_{\text{IN}-} = 48\text{ V}$, unless otherwise noted.

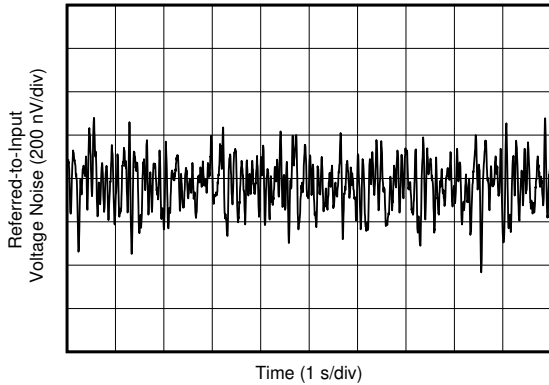

Figure 6-25. Input Referred Noise

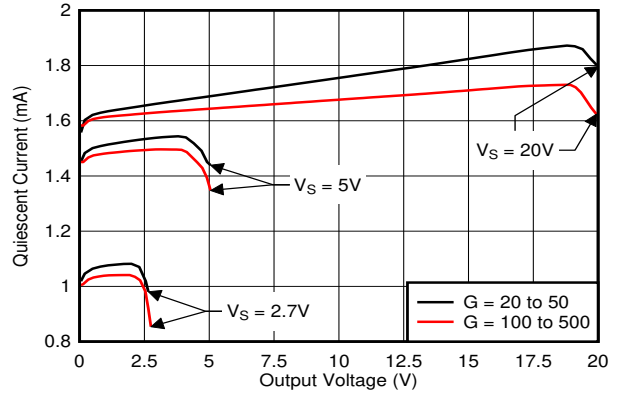

Figure 6-26. Quiescent Current vs Output Voltage

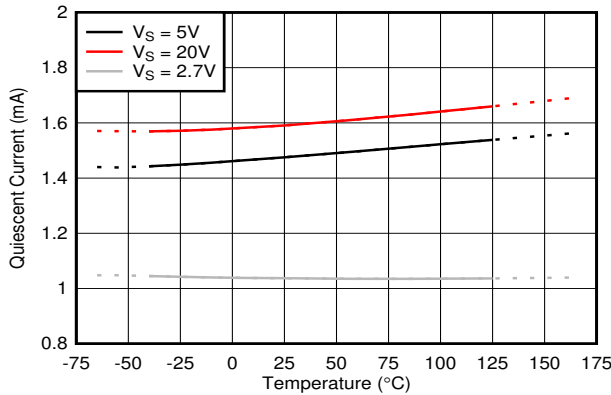

Figure 6-27. Quiescent Current vs Temperature

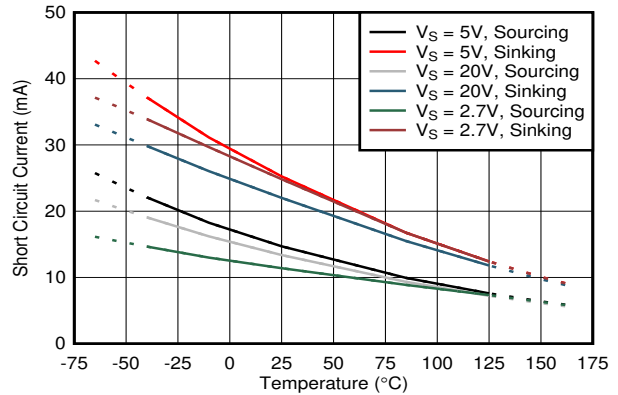

Figure 6-28. Short-Circuit Current vs Temperature

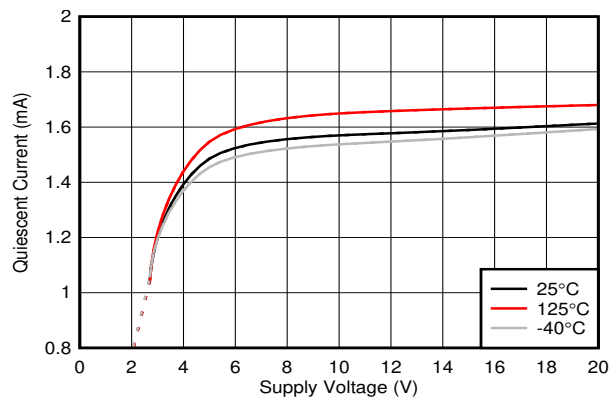

Figure 6-29. Quiescent Current vs Supply Voltage

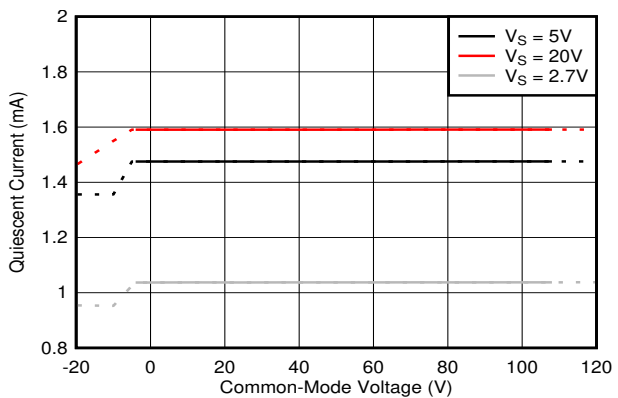

Figure 6-30. Quiescent Current vs Common-Mode Voltage

6.6 Typical Characteristics (continued)

All specifications at $T_A = 25\text{ }^\circ\text{C}$, $V_S = 5\text{ V}$, $V_{SENSE} = V_{IN+} - V_{IN-} = 0.5\text{ V / Gain}$, $V_{CM} = V_{IN-} = 48\text{ V}$, unless otherwise noted.

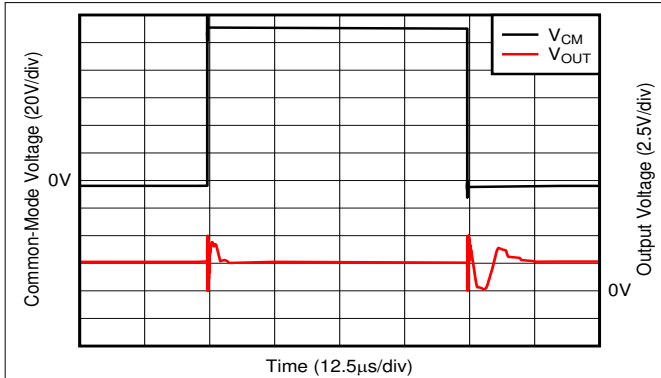

Figure 6-31. Common-Mode Voltage Fast Transient Pulse

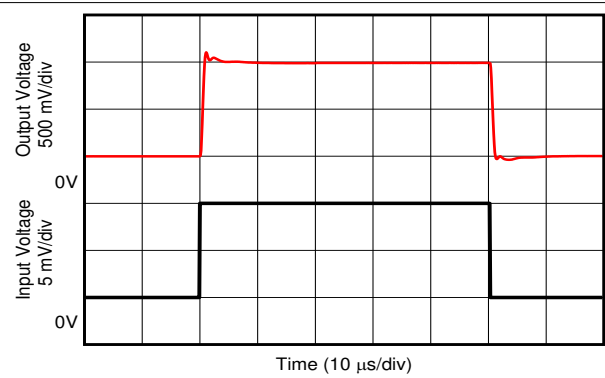

Figure 6-32. INA293x3 Step Response

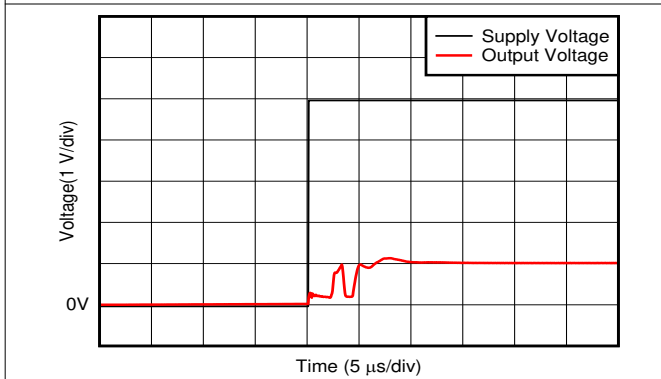

Figure 6-33. Start-Up Response

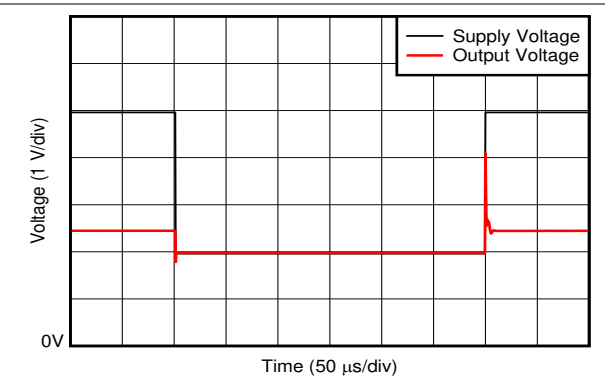

Figure 6-34. Supply Transient Response

7 Detailed Description

7.1 Overview

The INA293-Q1 is a high- or low-side current-sense amplifier that offers a wide common-mode range, precision zero-drift topology, excellent common-mode rejection ratio (CMRR), high bandwidth and fast slew rate. Different gain versions are available to optimize the output dynamic range based on the application. The INA293-Q1 is designed using a transconductance architecture with a current-feedback amplifier that enables low bias currents of 20 μA with a common-mode voltage of 110 V.

7.2 Functional Block Diagram

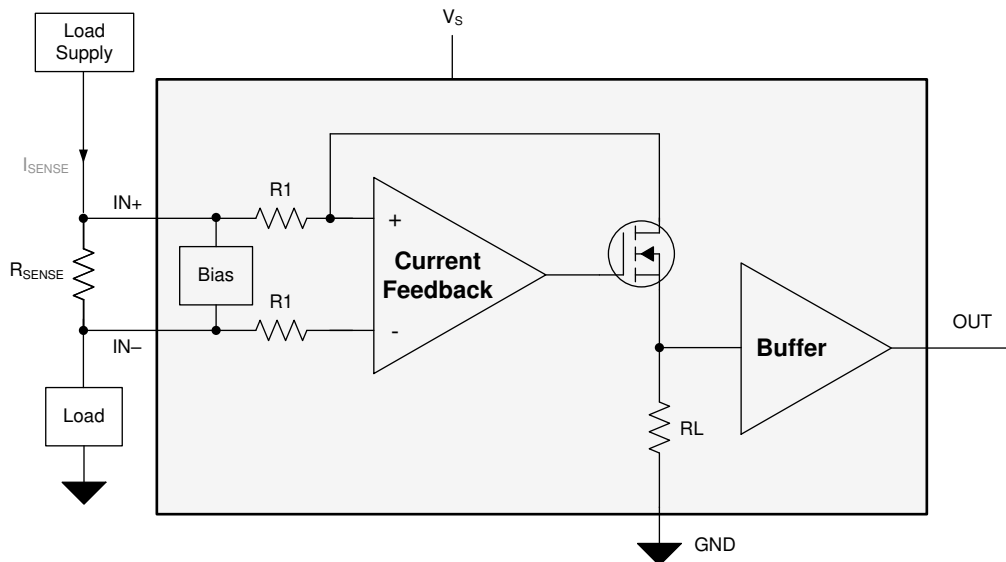

7.3 Feature Description

7.3.1 Amplifier Input Common-Mode Signal

The INA293-Q1 supports large input common-mode voltages from -4 V to $+110\text{ V}$. Because of the internal topology, the common-mode range is not restricted by the power-supply voltage (V_S). This allows for the INA293-Q1 to be used for both low and high side current-sensing applications.

7.3.1.1 Input-Signal Bandwidth

The INA293-Q1 -3-dB bandwidth is gain dependent, with several gain options of 20 V/V, 50 V/V, 100 V/V, 200 V/V, and 500 V/V. The unique multistage design enables the amplifier to achieve high bandwidth at all gains. This high bandwidth provides the throughput and fast response that is required for the rapid detection and processing of overcurrent events.

The bandwidth of the device also depends on the applied V_{SENSE} voltage. [Figure 7-1](#) shows the bandwidth performance profile of the device over frequency as output voltage increases for each gain variation. As shown in [Figure 7-1](#), the device exhibits the highest bandwidth with higher V_{SENSE} voltages, and the bandwidth is higher with lower device gain options. Individual requirements determine the acceptable limits of error for high frequency current-sensing applications. Testing and evaluation in the end application or circuit is required to determine the acceptance criteria, and to validate that the performance levels meet the system specifications.

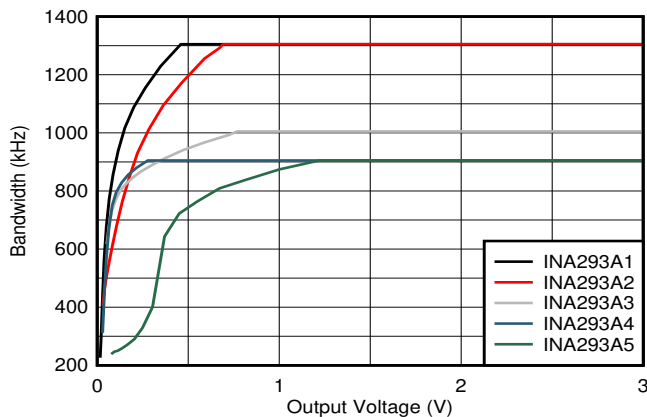

Figure 7-1. Bandwidth vs Output Voltage

7.3.1.2 Low Input Bias Current

The INA293-Q1 inputs draw a 20- μ A (typical) bias current at a common-mode voltage as high as 110 V, which enables precision current sensing on applications that require lower current leakage.

7.3.1.3 Low V_{SENSE} Operation

The INA293-Q1 operates with high performance across the entire valid V_{SENSE} range. The zero-drift input architecture of the INA293-Q1 provides the low offset voltage and low offset drift needed to measure low V_{SENSE} levels accurately across the wide operating temperature of -40°C to $+125^{\circ}\text{C}$. Low V_{SENSE} operation is particularly beneficial when using low ohmic shunts for low current measurements, as power losses across the shunt are significantly reduced.

7.3.1.4 Wide Fixed Gain Output

The INA293-Q1 gain error is $< 0.15\%$ at room temperature, with a maximum drift of 10 ppm/ $^{\circ}\text{C}$ over the full temperature range of -40°C to $+125^{\circ}\text{C}$. The INA293-Q1 is available in multiple gain options of 20 V/V, 50 V/V, 100 V/V, 200 V/V, and 500 V/V, which the system designer should select based on their desired signal-to-noise ratio and other system requirements.

The INA293-Q1 closed-loop gain is set by a precision, low drift internal resistor network. The ratio of these resistors are excellently matched, while the absolute values may vary significantly. Adding additional resistance around the INA293-Q1 to change the effective gain is not recommended, however, because of this variation. The typical values of the gain resistors are described in [Table 7-1](#).

Table 7-1. Fixed Gain Resistor

GAIN	R1	RL
20 (V/V)	25 k Ω	500 k Ω
50 (V/V)	10 k Ω	500 k Ω
100 (V/V)	10 k Ω	1000 k Ω
200 (V/V)	5 k Ω	1000 k Ω
500 (V/V)	2 k Ω	1000 k Ω

7.3.1.5 Wide Supply Range

The INA293-Q1 operates with a wide supply range from 2.7 V to 20 V. The output stage supports a wide output range while INA293-Q1x1 (gain of 20 V/V) at a supply voltage of 20 V allows a maximum acceptable differential input of 1 V. When paired with the small input offset voltage of the INA293-Q1, systems with very wide dynamic range of current measurement can be supported.

7.4 Device Functional Modes

7.4.1 Unidirectional Operation

The INA293-Q1 measures the differential voltage developed by current flowing through a resistor, commonly referred to as a current-sensing resistor or a current-shunt resistor. The INA293-Q1 operates in unidirectional mode only, meaning it only senses current sourced from a power supply to a system load as shown in Figure 7-2.

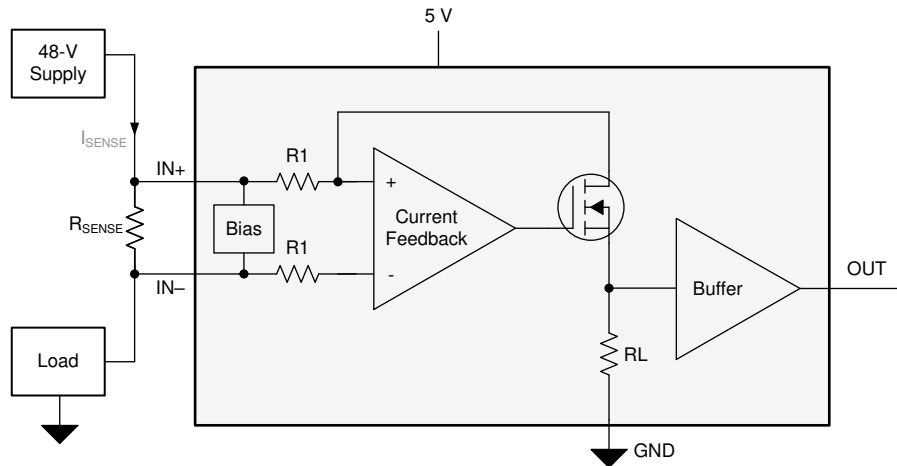

Figure 7-2. Unidirectional Application

The linear range of the output stage is limited to how close the output voltage can approach ground under zero-input conditions. The zero current output voltage of the INA293-Q1 is very small, with a maximum of GND + 20 mV. Make sure to apply a differential input voltage of (20 mV / Gain) or greater to keep the INA293-Q1 output in the linear region of operation.

7.4.2 High Signal Throughput

With a bandwidth of 1.3 MHz at a gain of 20 V/V and a slew rate of 2.5 V/ μ s, the INA293-Q1 is specifically designed for detecting and protecting applications from fast inrush currents. As shown in Table 7-2, the INA293-Q1 responds in less than 2 μ s for a system measuring a 75-A threshold on a 2-m Ω shunt.

Table 7-2. Response Time

PARAMETER		EQUATION	INA293-Q1 AT $V_S = 5\text{ V}$
G	Gain		20 V/V
I_{MAX}	Maximum current		100 A
$I_{Threshold}$	Threshold current		75 A
R_{SENSE}	Current sense resistor value		2 m Ω
V_{OUT_MAX}	Output voltage at maximum current	$V_{OUT_MAX} = I_{MAX} \times R_{SENSE} \times G$	4 V
V_{OUT_THR}	Output voltage at threshold current	$V_{OUT_THR} = I_{THR} \times R_{SENSE} \times G$	3 V
SR	Slew rate		2.5 V/ μ s
	Output response time	$T_{response} = V_{OUT_THR} / SR$	< 2 μ s

8 Application and Implementation

Note

Information in the following applications sections is not part of the TI component specification, and TI does not warrant its accuracy or completeness. TI's customers are responsible for determining suitability of components for their purposes, as well as validating and testing their design implementation to confirm system functionality.

8.1 Application Information

The INA293-Q1 amplifies the voltage developed across a current-sensing resistor as current flows through the resistor to the load. The wide input common-mode voltage range and high common-mode rejection of the INA293-Q1 make it usable over a wide range of voltage rails while still maintaining an accurate current measurement.

8.1.1 R_{SENSE} and Device Gain Selection

The accuracy of any current-sense amplifier is maximized by choosing the current-sense resistor to be as large as possible. A large sense resistor maximizes the differential input signal for a given amount of current flow and reduces the error contribution of the offset voltage. However, there are practical limits as to how large the current-sense resistor can be in a given application because of the resistor size and maximum allowable power dissipation. Equation 1 gives the maximum value for the current-sense resistor for a given power dissipation budget:

$$R_{\text{SENSE}} < \frac{PD_{\text{MAX}}}{I_{\text{MAX}}^2} \quad (1)$$

where:

- PD_{MAX} is the maximum allowable power dissipation in R_{SENSE} .
- I_{MAX} is the maximum current that will flow through R_{SENSE} .

An additional limitation on the size of the current-sense resistor and device gain is due to the power-supply voltage, V_S , and device swing-to-rail limitations. To make sure that the current-sense signal is properly passed to the output, both positive and negative output swing limitations must be examined. Equation 2 provides the maximum values of R_{SENSE} and GAIN to keep the device from exceeding the positive swing limitation.

$$I_{\text{MAX}} \times R_{\text{SENSE}} \times \text{GAIN} < V_{\text{SP}} \quad (2)$$

where:

- I_{MAX} is the maximum current that will flow through R_{SENSE} .
- GAIN is the gain of the current-sense amplifier.
- V_{SP} is the positive output swing as specified in the data sheet.

To avoid positive output swing limitations when selecting the value of R_{SENSE} , there is always a trade-off between the value of the sense resistor and the gain of the device under consideration. If the sense resistor selected for the maximum power dissipation is too large, then it is possible to select a lower-gain device in order to avoid positive swing limitations.

The negative swing limitation places a limit on how small the sense resistor value can be for a given application. Equation 3 provides the limit on the minimum value of the sense resistor.

$$I_{\text{MIN}} \times R_{\text{SENSE}} \times \text{GAIN} > V_{\text{SN}} \quad (3)$$

where:

- I_{MIN} is the minimum current that will flow through R_{SENSE} .

- GAIN is the gain of the current-sense amplifier.
- V_{SN} is the negative output swing of the device.

Table 8-1 shows an example of the different results obtained from using five different gain versions of the INA293-Q1. From the table data, the highest gain device allows a smaller current-shunt resistor and decreased power dissipation in the element.

Table 8-1. R_{SENSE} Selection and Power Dissipation⁽¹⁾

PARAMETER		EQUATION	RESULTS AT $V_S = 5\text{ V}$				
			A1, B1 DEVICES	A2, B2 DEVICES	A3, B3 DEVICES	A4, B4 DEVICES	A5, B5 DEVICES
G	Gain		20 V/V	50 V/V	100 V/V	200 V/V	500 V/V
V_{DIFF}	Ideal differential input voltage	$V_{DIFF} = V_{OUT} / G$	250 mV	100 mV	50 mV	25 mV	10 mV
R_{SENSE}	Current sense resistor value	$R_{SENSE} = V_{DIFF} / I_{MAX}$	25 m Ω	10 m Ω	5 m Ω	2.5 m Ω	1 m Ω
P_{SENSE}	Current-sense resistor power dissipation	$R_{SENSE} \times I_{MAX}^2$	2.5 W	1 W	0.5W	0.25 W	0.1 W

(1) Design example with 10-A full-scale current with maximum output voltage set to 5 V.

8.1.2 Input Filtering

Note

Input filters are not required for accurate measurements using the INA293-Q1, and use of filters in this location is not recommended. If filter components are used on the input of the amplifier, follow the guidelines in this section to minimize the effects on performance.

Based strictly on user design requirements, external filtering of the current signal may be desired. The initial location that can be considered for the filter is at the output of the current sense amplifier. Although placing the filter at the output satisfies the filtering requirements, this location changes the low output impedance measured by any circuitry connected to the output voltage pin. The other location for filter placement is at the current sense amplifier input pins. This location satisfies the filtering requirement also, however the components must be carefully selected to minimally impact device performance. Figure 8-1 shows a filter placed at the input pins.

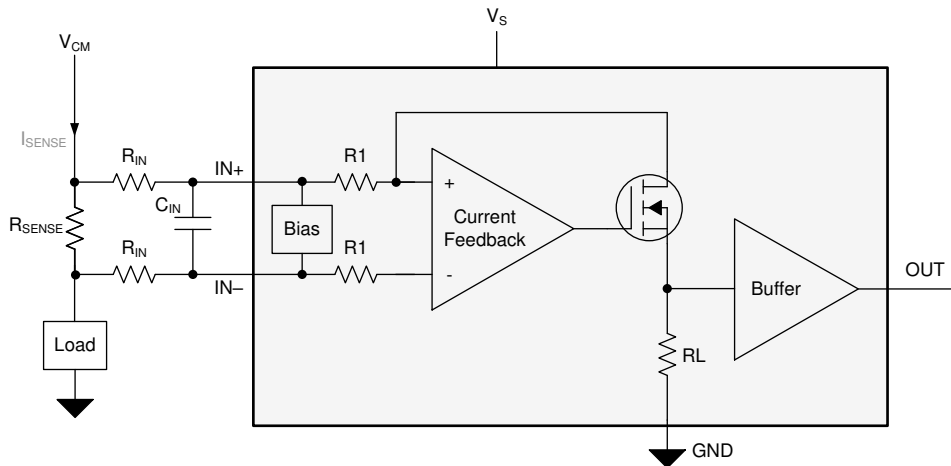

Figure 8-1. Filter at Input Pins

External series resistance provides a source of additional measurement error, so keep the value of these series resistors to 10 Ω or less to reduce loss of accuracy. The internal bias network shown in Figure 8-1 creates a mismatch in input bias currents (see Figure 6-15, Figure 6-16 and Figure 6-17) when a differential voltage is applied between the input pins. If additional external series filter resistors are added to the circuit, a mismatch is created in the voltage drop across the filter resistors. This voltage is a differential error voltage in the shunt resistor voltage. In addition to the absolute resistor value, mismatch resulting from resistor tolerance can significantly impact the error because this value is calculated based on the actual measured resistance.

The measurement error expected from the additional external filter resistors can be calculated using Equation 4, where the gain error factor is calculated using Equation 5.

$$\text{Gain Error (\%)} = 100 - (100 \times \text{Gain Error Factor}) \tag{4}$$

The gain error factor, shown in Equation 4, can be calculated to determine the gain error introduced by the additional external series resistance. Equation 4 calculates the deviation of the shunt voltage, resulting from the attenuation and imbalance created by the added external filter resistance. Table 8-2 provides the gain error factor and gain error for several resistor values.

$$\text{Gain Error Factor} = \frac{R_B \times R_1}{(R_B \times R_1) + (R_B \times R_{IN}) + (2 \times R_{IN} \times R_1)} \tag{5}$$

Where:

- R_{IN} is the external filter resistance value.
- R_1 is the INA293-Q1 input resistance value specified in Table 7-1.
- R_B in the internal bias resistance, which is $6600 \Omega \pm 20\%$.

Table 8-2. Example Gain Error Factor and Gain Error for 10-Ω External Filter Input Resistors

DEVICE (GAIN)	GAIN ERROR FACTOR	GAIN ERROR (%)
INA293-Q1x1 (20)	0.997108386	-0.289161432
INA293-Q1x2 (50)	0.996512207	-0.348779273
INA293-Q1x3 (100)	0.996512207	-0.348779273
INA293-Q1x4 (200)	0.995520159	-0.447984072
INA293-Q1x5 (500)	0.992555831	-0.744416873

8.2 Typical Application

The INA293-Q1 is a unidirectional, current-sense amplifier capable of measuring currents through a resistive shunt with shunt common-mode voltages from -4 V to +110 V.

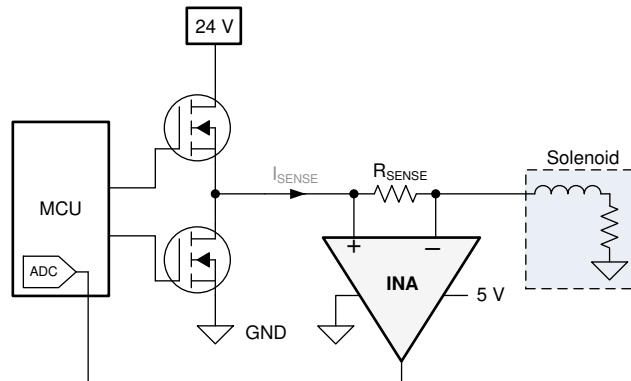

Figure 8-2. Current Sensing in a Solenoid Application

8.2.1 Design Requirements

In this example application, the common-mode voltage ranges from 0 V to 24 V. The maximum sense current is 1.5 A, and a 5-V supply is available for the INA293-Q1. Following the design guidelines from the *R_{SENSE} and Device Gain Selection* section, a R_{SENSE} of 50 mΩ and a gain of 50 V/V are selected to provide good output dynamic range. Table 8-3 lists the design setup for this application.

Table 8-3. Design Parameters

DESIGN PARAMETERS	EXAMPLE VALUE
Power supply voltage	5 V

Table 8-3. Design Parameters (continued)

DESIGN PARAMETERS	EXAMPLE VALUE
Common-mode voltage range	0 V to 24 V
Maximum sense current	1.5 A
R _{SENSE} resistor	50 mΩ
Gain option	50 V/V

8.2.2 Detailed Design Procedure

The INA293-Q1 is designed to measure current in a typical solenoid application. The INA293-Q1 measures current across the 50-mΩ shunt that is placed at the output of the half-bridge. The INA293-Q1 measures the differential voltage across the shunt resistor, and the signal is internally amplified with a gain of 50 V/V. The output of the INA293-Q1 is connected to the analog-to-digital converter (ADC) of an MCU to digitize the current measurements.

Solenoid loads are highly inductive and are often prone to failure. Solenoids are often used for position control, precise fluid control, and fluid regulation. Measuring real-time current on the solenoid continuously can indicate premature failure of the solenoid which can lead to a faulty control loop in the system. Measuring high-side current also indicates if there are any ground faults on the solenoid or the FETs that can be damaged in an application. The INA293-Q1, with high bandwidth and slew rate, can be used to detect fast overcurrent conditions to prevent the solenoid damage from short-to-ground faults.

8.2.2.1 Overload Recovery With Negative V_{SENSE}

The INA293-Q1 is a unidirectional current sense amplifier that is meant to operate with a positive differential input voltage (V_{SENSE}). If negative V_{SENSE} is applied, the device is placed in an overload condition and requires time to recover once V_{SENSE} returns positive. The required overload recovery time increases with more negative V_{SENSE}.

8.2.3 Application Curve

Figure 8-3 shows the output response of a solenoid.

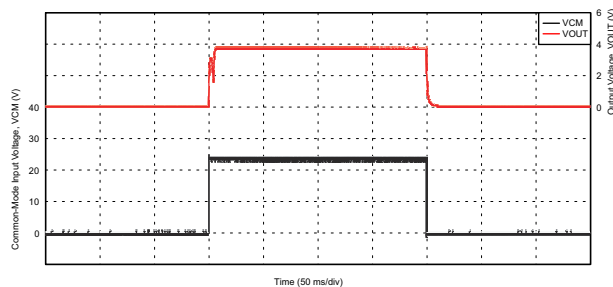

Figure 8-3. Solenoid Control Current Response

8.3 Power Supply Recommendations

The INA293-Q1 power supply can be 5 V, whereas the input common-mode voltage can vary between -4 V to 110 V. The output voltage range of the OUT pin, however, is limited by the voltage on the power-supply pin.

8.4 Layout

8.4.1 Layout Guidelines

Attention to good layout practices is always recommended.

- Connect the input pins to the sensing resistor using a Kelvin or 4-wire connection. This connection technique makes sure that only the current-sensing resistor impedance is detected between the input pins. Poor routing of the current-sensing resistor commonly results in additional resistance present between the input pins.

Given the very low ohmic value of the current resistor, any additional high-current carrying impedance can cause significant measurement errors.

- Place the power-supply bypass capacitor as close as possible to the device power supply and ground pins. The recommended value of this bypass capacitor is 0.1 μF . Additional decoupling capacitance can be added to compensate for noisy or high-impedance power supplies.

8.4.2 Layout Example

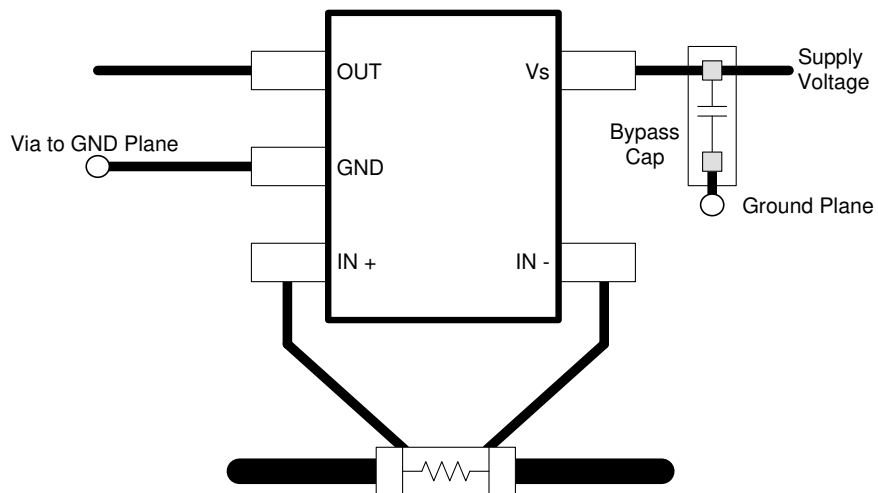

Figure 8-4. INA293A-Q1 Recommended Layout

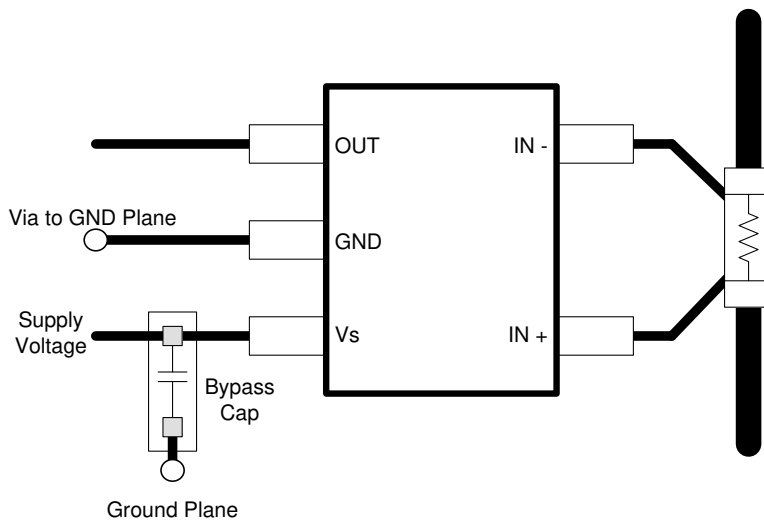

Figure 8-5. INA293B-Q1 Recommended Layout

9 Device and Documentation Support

9.1 Documentation Support

9.1.1 Related Documentation

For related documentation see the following: Texas Instruments, [INA293EVM user's guide](#).

9.2 Receiving Notification of Documentation Updates

To receive notification of documentation updates, navigate to the device product folder on [ti.com](#). Click on *Subscribe to updates* to register and receive a weekly digest of any product information that has changed. For change details, review the revision history included in any revised document.

9.3 Support Resources

[TI E2E™ support forums](#) are an engineer's go-to source for fast, verified answers and design help — straight from the experts. Search existing answers or ask your own question to get the quick design help you need.

Linked content is provided "AS IS" by the respective contributors. They do not constitute TI specifications and do not necessarily reflect TI's views; see TI's [Terms of Use](#).

9.4 Trademarks

TI E2E™ is a trademark of Texas Instruments.
All trademarks are the property of their respective owners.

9.5 Electrostatic Discharge Caution



This integrated circuit can be damaged by ESD. Texas Instruments recommends that all integrated circuits be handled with appropriate precautions. Failure to observe proper handling and installation procedures can cause damage.

ESD damage can range from subtle performance degradation to complete device failure. Precision integrated circuits may be more susceptible to damage because very small parametric changes could cause the device not to meet its published specifications.

9.6 Glossary

[TI Glossary](#) This glossary lists and explains terms, acronyms, and definitions.

10 Mechanical, Packaging, and Orderable Information

The following pages include mechanical, packaging, and orderable information. This information is the most current data available for the designated devices. This data is subject to change without notice and revision of this document. For browser-based versions of this data sheet, refer to the left-hand navigation.

PACKAGING INFORMATION

Orderable Device	Status (1)	Package Type	Package Drawing	Pins	Package Qty	Eco Plan (2)	Lead finish/ Ball material (6)	MSL Peak Temp (3)	Op Temp (°C)	Device Marking (4/5)	Samples
INA293A1QDBVRQ1	ACTIVE	SOT-23	DBV	5	3000	RoHS & Green	NIPDAU	Level-1-260C-UNLIM	-40 to 125	1UZC	Samples
INA293A2QDBVRQ1	ACTIVE	SOT-23	DBV	5	3000	RoHS & Green	NIPDAU	Level-1-260C-UNLIM	-40 to 125	1V1C	Samples
INA293A3QDBVRQ1	ACTIVE	SOT-23	DBV	5	3000	RoHS & Green	NIPDAU	Level-1-260C-UNLIM	-40 to 125	1V2C	Samples
INA293A4QDBVRQ1	ACTIVE	SOT-23	DBV	5	3000	RoHS & Green	NIPDAU	Level-1-260C-UNLIM	-40 to 125	1V3C	Samples
INA293A5QDBVRQ1	ACTIVE	SOT-23	DBV	5	3000	RoHS & Green	NIPDAU	Level-1-260C-UNLIM	-40 to 125	1V4C	Samples
INA293B1QDBVRQ1	ACTIVE	SOT-23	DBV	5	3000	RoHS & Green	NIPDAU	Level-1-260C-UNLIM	-40 to 125	1V5C	Samples
INA293B2QDBVRQ1	ACTIVE	SOT-23	DBV	5	3000	RoHS & Green	NIPDAU	Level-1-260C-UNLIM	-40 to 125	1V6C	Samples
INA293B3QDBVRQ1	ACTIVE	SOT-23	DBV	5	3000	RoHS & Green	NIPDAU	Level-1-260C-UNLIM	-40 to 125	1V7C	Samples
INA293B4QDBVRQ1	ACTIVE	SOT-23	DBV	5	3000	RoHS & Green	NIPDAU	Level-1-260C-UNLIM	-40 to 125	1V8C	Samples
INA293B5QDBVRQ1	ACTIVE	SOT-23	DBV	5	3000	RoHS & Green	NIPDAU	Level-1-260C-UNLIM	-40 to 125	1V9C	Samples

(1) The marketing status values are defined as follows:

ACTIVE: Product device recommended for new designs.

LIFEBUY: TI has announced that the device will be discontinued, and a lifetime-buy period is in effect.

NRND: Not recommended for new designs. Device is in production to support existing customers, but TI does not recommend using this part in a new design.

PREVIEW: Device has been announced but is not in production. Samples may or may not be available.

OBSOLETE: TI has discontinued the production of the device.

(2) **RoHS:** TI defines "RoHS" to mean semiconductor products that are compliant with the current EU RoHS requirements for all 10 RoHS substances, including the requirement that RoHS substance do not exceed 0.1% by weight in homogeneous materials. Where designed to be soldered at high temperatures, "RoHS" products are suitable for use in specified lead-free processes. TI may reference these types of products as "Pb-Free".

RoHS Exempt: TI defines "RoHS Exempt" to mean products that contain lead but are compliant with EU RoHS pursuant to a specific EU RoHS exemption.

Green: TI defines "Green" to mean the content of Chlorine (Cl) and Bromine (Br) based flame retardants meet JS709B low halogen requirements of <=1000ppm threshold. Antimony trioxide based flame retardants must also meet the <=1000ppm threshold requirement.

(3) MSL, Peak Temp. - The Moisture Sensitivity Level rating according to the JEDEC industry standard classifications, and peak solder temperature.

(4) There may be additional marking, which relates to the logo, the lot trace code information, or the environmental category on the device.

⁽⁵⁾ Multiple Device Markings will be inside parentheses. Only one Device Marking contained in parentheses and separated by a "~" will appear on a device. If a line is indented then it is a continuation of the previous line and the two combined represent the entire Device Marking for that device.

⁽⁶⁾ Lead finish/Ball material - Orderable Devices may have multiple material finish options. Finish options are separated by a vertical ruled line. Lead finish/Ball material values may wrap to two lines if the finish value exceeds the maximum column width.

Important Information and Disclaimer:The information provided on this page represents TI's knowledge and belief as of the date that it is provided. TI bases its knowledge and belief on information provided by third parties, and makes no representation or warranty as to the accuracy of such information. Efforts are underway to better integrate information from third parties. TI has taken and continues to take reasonable steps to provide representative and accurate information but may not have conducted destructive testing or chemical analysis on incoming materials and chemicals. TI and TI suppliers consider certain information to be proprietary, and thus CAS numbers and other limited information may not be available for release.

In no event shall TI's liability arising out of such information exceed the total purchase price of the TI part(s) at issue in this document sold by TI to Customer on an annual basis.

OTHER QUALIFIED VERSIONS OF INA293-Q1 :

- Catalog : [INA293](#)

NOTE: Qualified Version Definitions:

- Catalog - TI's standard catalog product

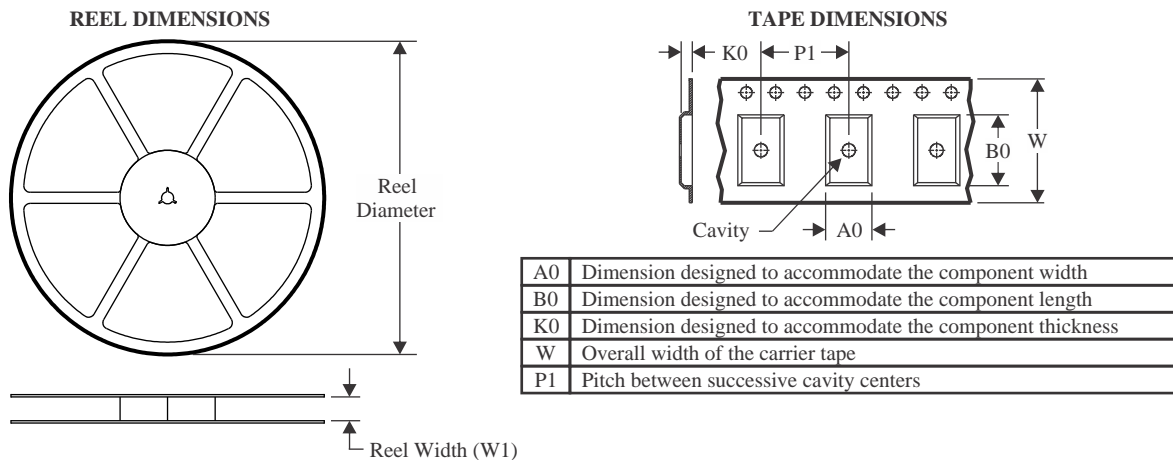
TAPE AND REEL INFORMATION

QUADRANT ASSIGNMENTS FOR PIN 1 ORIENTATION IN TAPE

*All dimensions are nominal

Device	Package Type	Package Drawing	Pins	SPQ	Reel Diameter (mm)	Reel Width W1 (mm)	A0 (mm)	B0 (mm)	K0 (mm)	P1 (mm)	W (mm)	Pin1 Quadrant
INA293A1QDBVRQ1	SOT-23	DBV	5	3000	180.0	8.4	3.23	3.17	1.37	4.0	8.0	Q3
INA293A2QDBVRQ1	SOT-23	DBV	5	3000	180.0	8.4	3.23	3.17	1.37	4.0	8.0	Q3
INA293A3QDBVRQ1	SOT-23	DBV	5	3000	180.0	8.4	3.23	3.17	1.37	4.0	8.0	Q3
INA293A4QDBVRQ1	SOT-23	DBV	5	3000	180.0	8.4	3.23	3.17	1.37	4.0	8.0	Q3
INA293A5QDBVRQ1	SOT-23	DBV	5	3000	180.0	8.4	3.23	3.17	1.37	4.0	8.0	Q3
INA293B1QDBVRQ1	SOT-23	DBV	5	3000	180.0	8.4	3.23	3.17	1.37	4.0	8.0	Q3
INA293B2QDBVRQ1	SOT-23	DBV	5	3000	180.0	8.4	3.23	3.17	1.37	4.0	8.0	Q3
INA293B3QDBVRQ1	SOT-23	DBV	5	3000	180.0	8.4	3.23	3.17	1.37	4.0	8.0	Q3
INA293B4QDBVRQ1	SOT-23	DBV	5	3000	180.0	8.4	3.23	3.17	1.37	4.0	8.0	Q3
INA293B5QDBVRQ1	SOT-23	DBV	5	3000	180.0	8.4	3.23	3.17	1.37	4.0	8.0	Q3

TAPE AND REEL BOX DIMENSIONS

*All dimensions are nominal

Device	Package Type	Package Drawing	Pins	SPQ	Length (mm)	Width (mm)	Height (mm)
INA293A1QDBVRQ1	SOT-23	DBV	5	3000	183.0	183.0	20.0
INA293A2QDBVRQ1	SOT-23	DBV	5	3000	183.0	183.0	20.0
INA293A3QDBVRQ1	SOT-23	DBV	5	3000	183.0	183.0	20.0
INA293A4QDBVRQ1	SOT-23	DBV	5	3000	183.0	183.0	20.0
INA293A5QDBVRQ1	SOT-23	DBV	5	3000	183.0	183.0	20.0
INA293B1QDBVRQ1	SOT-23	DBV	5	3000	183.0	183.0	20.0
INA293B2QDBVRQ1	SOT-23	DBV	5	3000	183.0	183.0	20.0
INA293B3QDBVRQ1	SOT-23	DBV	5	3000	183.0	183.0	20.0
INA293B4QDBVRQ1	SOT-23	DBV	5	3000	183.0	183.0	20.0
INA293B5QDBVRQ1	SOT-23	DBV	5	3000	183.0	183.0	20.0

EXAMPLE BOARD LAYOUT

DBV0005A

SOT-23 - 1.45 mm max height

SMALL OUTLINE TRANSISTOR

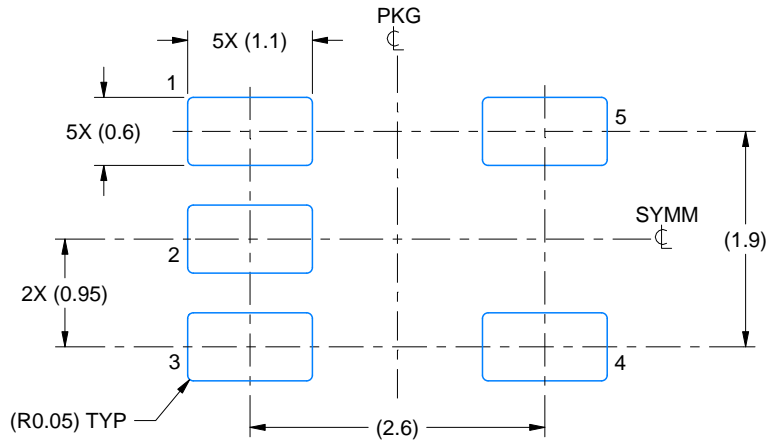

LAND PATTERN EXAMPLE
EXPOSED METAL SHOWN
SCALE:15X

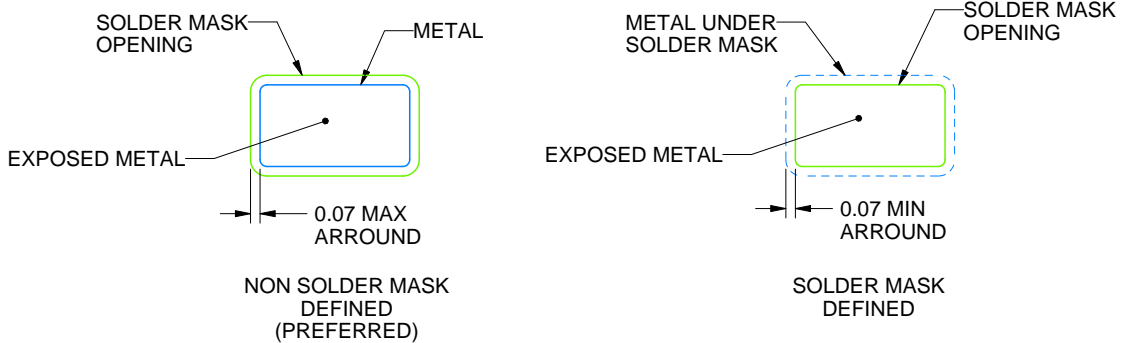

SOLDER MASK DETAILS

4214839/J 02/2024

NOTES: (continued)

6. Publication IPC-7351 may have alternate designs.
7. Solder mask tolerances between and around signal pads can vary based on board fabrication site.

EXAMPLE STENCIL DESIGN

DBV0005A

SOT-23 - 1.45 mm max height

SMALL OUTLINE TRANSISTOR



SOLDER PASTE EXAMPLE
BASED ON 0.125 mm THICK STENCIL
SCALE:15X

4214839/J 02/2024

NOTES: (continued)

8. Laser cutting apertures with trapezoidal walls and rounded corners may offer better paste release. IPC-7525 may have alternate design recommendations.
9. Board assembly site may have different recommendations for stencil design.

IMPORTANT NOTICE AND DISCLAIMER

TI PROVIDES TECHNICAL AND RELIABILITY DATA (INCLUDING DATA SHEETS), DESIGN RESOURCES (INCLUDING REFERENCE DESIGNS), APPLICATION OR OTHER DESIGN ADVICE, WEB TOOLS, SAFETY INFORMATION, AND OTHER RESOURCES "AS IS" AND WITH ALL FAULTS, AND DISCLAIMS ALL WARRANTIES, EXPRESS AND IMPLIED, INCLUDING WITHOUT LIMITATION ANY IMPLIED WARRANTIES OF MERCHANTABILITY, FITNESS FOR A PARTICULAR PURPOSE OR NON-INFRINGEMENT OF THIRD PARTY INTELLECTUAL PROPERTY RIGHTS.

These resources are intended for skilled developers designing with TI products. You are solely responsible for (1) selecting the appropriate TI products for your application, (2) designing, validating and testing your application, and (3) ensuring your application meets applicable standards, and any other safety, security, regulatory or other requirements.

These resources are subject to change without notice. TI grants you permission to use these resources only for development of an application that uses the TI products described in the resource. Other reproduction and display of these resources is prohibited. No license is granted to any other TI intellectual property right or to any third party intellectual property right. TI disclaims responsibility for, and you will fully indemnify TI and its representatives against, any claims, damages, costs, losses, and liabilities arising out of your use of these resources.

TI's products are provided subject to [TI's Terms of Sale](#) or other applicable terms available either on [ti.com](https://www.ti.com) or provided in conjunction with such TI products. TI's provision of these resources does not expand or otherwise alter TI's applicable warranties or warranty disclaimers for TI products.

TI objects to and rejects any additional or different terms you may have proposed.

Mailing Address: Texas Instruments, Post Office Box 655303, Dallas, Texas 75265
Copyright © 2024, Texas Instruments Incorporated

Looking for pricing, stock, or lifecycle information?

Click below to explore more details on WIN SOURCE:

 [View INA293A2QDBVRQ1 on WIN SOURCE](#)

 [Texas Instruments](#) Information

Optimize Your Supply Chain with WIN SOURCE Solutions

-  Global Sourcing Solution
-  Obsolete Management
-  Cost Control Management
-  Shortage Management
-  Alternative Solution
-  Excess Inventory Management