



**THE DATASHEET OF  
DC2279A**



# 800mA Single Resistor Rugged Linear Regulator

## FEATURES

- Extended Safe Operating Area
- Maximum Output Current: 800mA
- Stable with or without Input/Output Capacitors
- Wide Input Voltage Range: 1.2V to 36V
- Single Resistor Sets Output Voltage
- Output Adjustable to 0V
- 50 $\mu$ A SET Pin Current: 1% Initial Accuracy
- Output Voltage Noise: 27 $\mu$ V<sub>RMS</sub>
- Parallel Multiple Devices for Higher Current, Heat Spreading and Lower Noise
- Pin Compatible Upgrade to LT1117
- Reverse-Battery and Reverse-Current Protection
- <1mV Typical Load Regulation Independent of V<sub>OUT</sub>
- <0.001%/V Typical Line Regulation
- 3-Lead SOT-223, 3-Lead DD-Pak, 8-Lead 3mm × 3mm DFN Packages

## APPLICATIONS

- All Surface Mount Power Supply
- Rugged Industrial Power Supply
- Post Regulator for Switching Supplies
- Low Output Voltage Supply
- Intrinsic Safety Applications

## DESCRIPTION

The **LT<sup>®</sup>3088** is an 800mA low dropout linear regulator designed for rugged industrial applications. A key feature of the IC is the extended safe operating area (SOA). The LT3088 can be paralleled for higher output current or heat spreading. The device withstands reverse input and reverse output-to-input voltages without reverse current flow.

The LT3088's precision 50 $\mu$ A reference current source allows a single resistor to program output voltage to any level between zero and 34.5V. The current reference architecture makes load regulation independent of output voltage. The LT3088 is stable with or without input and output capacitors.

Internal protection circuitry includes reverse-battery and reverse-current protection, current limiting and thermal limiting. The LT3088 is offered in the 3-lead SOT-223, 3-lead DD-Pak, and an 8-lead 3mm × 3mm DFN package.

LT, LT, LTC, LTM, Linear Technology and the Linear logo are registered trademarks of Linear Technology Corporation. All other trademarks are the property of their respective owners.

## TYPICAL APPLICATION

Wide Safe Operating Area Supply

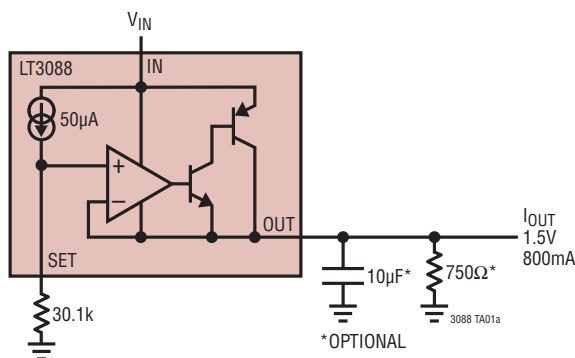

SET Pin Current

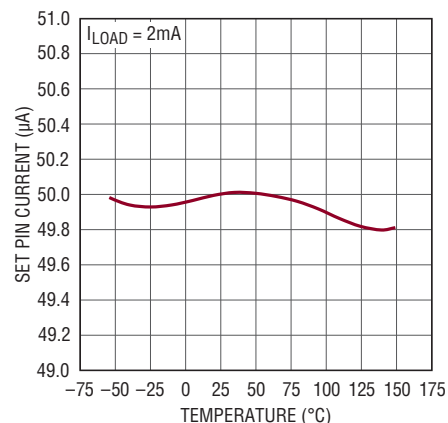

3088 G01

3088fb

# LT3088

## ABSOLUTE MAXIMUM RATINGS (Note 1) All voltages Relative to $V_{OUT}$

IN Pin to OUT Pin Differential Voltage.....	$\pm 40V$	Storage Temperature Range .....	$-65^{\circ}C$ to $150^{\circ}C$
SET Pin Current (Note 6) .....	$\pm 25mA$	Lead Temperature (Soldering, 10 sec)	
SET Pin Voltage (Relative to OUT, Note 6) .....	$\pm 10V$	M, ST Packages Only .....	$300^{\circ}C$
Output Short-Circuit Duration .....	Indefinite		
Operating Junction Temperature Range (Note 2)			
E-, I-Grades .....	$-40^{\circ}C$ to $125^{\circ}C$		
H-Grade .....	$-40^{\circ}C$ to $150^{\circ}C$		
MP-Grade .....	$-55^{\circ}C$ to $150^{\circ}C$		

## PIN CONFIGURATION

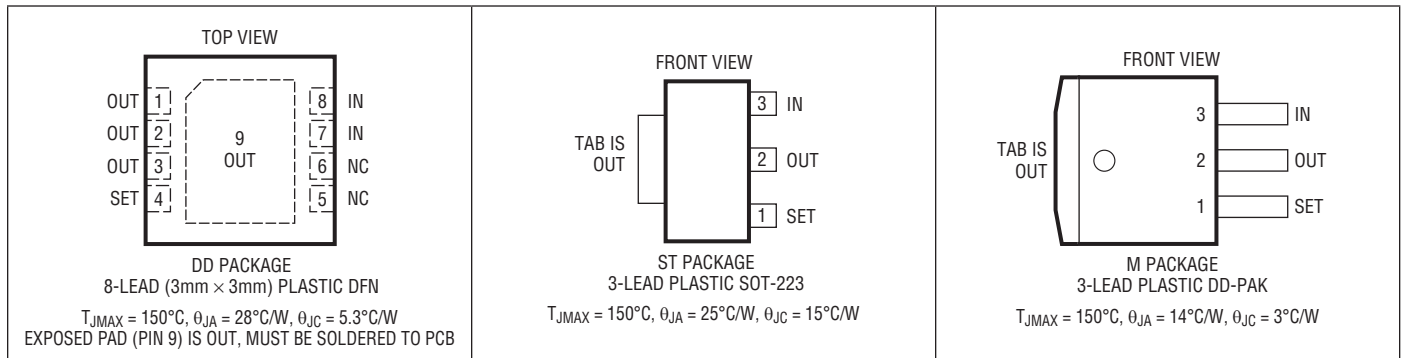

## ORDER INFORMATION

LEAD FREE FINISH	TAPE AND REEL	PART MARKING*	PACKAGE DESCRIPTION	TEMPERATURE RANGE
LT3088EDD#PBF	LT3088EDD#TRPBF	LGSZ	8-Lead (3mm × 3mm) Plastic DFN	$-40^{\circ}C$ to $125^{\circ}C$
LT3088IDD#PBF	LT3088IDD#TRPBF	LGSZ	8-Lead (3mm × 3mm) Plastic DFN	$-40^{\circ}C$ to $125^{\circ}C$
LT3088HDD#PBF	LT3088HDD#TRPBF	LGSZ	8-Lead (3mm × 3mm) Plastic DFN	$-40^{\circ}C$ to $150^{\circ}C$
LT3088EST#PBF	LT3088EST#TRPBF	3088	3-Lead Plastic SOT-223	$-40^{\circ}C$ to $125^{\circ}C$
LT3088IST#PBF	LT3088IST#TRPBF	3088	3-Lead Plastic SOT-223	$-40^{\circ}C$ to $125^{\circ}C$
LT3088HST#PBF	LT3088HST#TRPBF	3088	3-Lead Plastic SOT-223	$-40^{\circ}C$ to $150^{\circ}C$
LT3088MPST#PBF	LT3088MPST#TRPBF	3088	3-Lead Plastic SOT-223	$-55^{\circ}C$ to $150^{\circ}C$
LT3088EM#PBF	LT3088EM#TRPBF	LT3088M	3-Lead Plastic DD-Pak	$-40^{\circ}C$ to $125^{\circ}C$
LT3088IM#PBF	LT3088IM#TRPBF	LT3088M	3-Lead Plastic DD-Pak	$-40^{\circ}C$ to $125^{\circ}C$
LT3088HM#PBF	LT3088HM#TRPBF	LT3088M	3-Lead Plastic DD-Pak	$-40^{\circ}C$ to $150^{\circ}C$
LT3088MPM#PBF	LT3088MPM#TRPBF	LT3088M	3-Lead Plastic DD-Pak	$-55^{\circ}C$ to $150^{\circ}C$

Consult LTC Marketing for parts specified with wider operating temperature ranges. \*The temperature grade is identified by a label on the shipping container. For more information on lead free part marking, go to: <http://www.linear.com/leadfree/>  
For more information on tape and reel specifications, go to: <http://www.linear.com/tapeandree/>. Some packages are available in 500 unit reels through designated sales channels with #TRMPBF suffix.

**ELECTRICAL CHARACTERISTICS** The ● denotes the specifications which apply over the full operating temperature range, otherwise specifications are at  $T_J = 25^\circ\text{C}$ . (Note 2)

PARAMETER	CONDITIONS	MIN	TYP	MAX	UNITS
SET Pin Current	$I_{SET}$ $V_{IN} = 2V, I_{LOAD} = 2mA$ $2V \leq V_{IN} \leq 36V, 2mA \leq I_{LOAD} \leq 800mA$	● 49.5 49	50 50	50.5 51	$\mu A$ $\mu A$
Offset Voltage ( $V_{OUT} - V_{SET}$ )	$V_{OS}$ $V_{IN} = 2V, I_{LOAD} = 2mA$ $V_{IN} = 2V, I_{LOAD} = 2mA$	● -1.5 -3.5	0 0	1.5 3.5	mV mV
$I_{SET}$ Load Regulation	$\Delta I_{LOAD} = 2mA$ to 800mA		-0.1		nA
$V_{OS}$ Load Regulation (Note 7)	$\Delta I_{LOAD} = 2mA$ to 800mA DD Package	●	-0.5	-3	mV
	M, ST Packages	●	-1.5	-4	mV
Line Regulation	$\Delta I_{SET}$ $\Delta V_{OS}$ $\Delta V_{IN} = 2V$ to 36V, $I_{LOAD} = 2mA$ $\Delta V_{IN} = 2V$ to 36V, $I_{LOAD} = 2mA$		1.5 0.001		nA/V mV/V
Minimum Load Current (Note 3)	$2V \leq V_{IN} \leq 36V$	●	0.4	2	mA
Dropout Voltage (Note 4)	$I_{LOAD} = 100mA$		1.21		V
	$I_{LOAD} = 800mA$	●	1.35	1.6	V
Current Limit	$V_{IN} = 5V, V_{SET} = 0V, V_{OUT} = -0.1V$	●	0.8	1.2	A
Reference Current RMS Output Noise (Note 5)	$10Hz \leq f \leq 100kHz$		5.7		nA <sub>RMS</sub>
Error Amplifier RMS Output Noise (Note 5)	$I_{LOAD} = 800mA, 10Hz \leq f \leq 100kHz,$ $C_{OUT} = 0\mu F, C_{SET} = 0.1\mu F$		27		$\mu V_{RMS}$
Ripple Rejection $V_{RIPPLE} = 0.5V_{P-P}, I_{LOAD} = 0.1A, C_{SET} = 0.1\mu F,$ $C_{OUT} = 10\mu F, V_{IN} = V_{OUT(NOMINAL)} + 3V$	$f = 120Hz$		75	90	dB
	$f = 10kHz$			75	dB
	$f = 1MHz$			20	dB
Thermal Regulation, $I_{SET}$	10ms Pulse		0.003		%/W

**Note 1:** Stresses beyond those listed under Absolute Maximum Ratings may cause permanent damage to the device. Exposure to any Absolute Maximum Rating condition for extended periods may affect device reliability and lifetime.

**Note 2:** Unless otherwise specified, all voltages are with respect to  $V_{OUT}$ . The LT3088 is tested and specified under pulse load conditions such that  $T_J \approx T_A$ . The LT3088E is tested at  $T_A = 25^\circ\text{C}$  and performance is guaranteed from  $0^\circ\text{C}$  to  $125^\circ\text{C}$ . Performance of the LT3088E over the full  $-40^\circ\text{C}$  and  $125^\circ\text{C}$  operating temperature range is assured by design, characterization, and correlation with statistical process controls. The LT3088I is guaranteed over the full  $-40^\circ\text{C}$  to  $125^\circ\text{C}$  operating junction temperature range. The LT3088MP is 100% tested and guaranteed over the  $-55^\circ\text{C}$  to  $150^\circ\text{C}$  operating junction temperature range. The LT3088H is tested at  $150^\circ\text{C}$  operating junction temperature. High junction temperatures degrade operating lifetimes. Operating lifetime is degraded at junction temperatures greater than  $125^\circ\text{C}$ .

**Note 3:** Minimum load current is equivalent to the quiescent current of the part. Since all quiescent and drive current is delivered to the output of the part, the minimum load current is the minimum current required to maintain regulation.

**Note 4:** For the LT3088, dropout is specified as the minimum input-to-output voltage differential required supplying a given output current.

**Note 5:** Adding a small capacitor across the reference current resistor lowers output noise. Adding this capacitor bypasses the resistor shot noise and reference current noise; output noise is then equal to error amplifier noise (see Applications Information section).

**Note 6:** Diodes with series  $400\Omega$  resistors clamp the SET pin to the OUT pin. These diodes and resistors only carry current under transient overloads. During normal operation, keep the OUT-to-SET differential voltage below 2V.

**Note 7:** Load regulation is Kelvin sensed at the package.

**Note 8:** This IC includes overtemperature protection that protects the device during momentary overload conditions. Junction temperature exceeds the maximum operating junction temperature when overtemperature protection is active. Continuous operation above the specified maximum operating junction temperature may impair device reliability.

**TYPICAL PERFORMANCE CHARACTERISTICS**  $T_J = 25^\circ\text{C}$  unless otherwise specified.

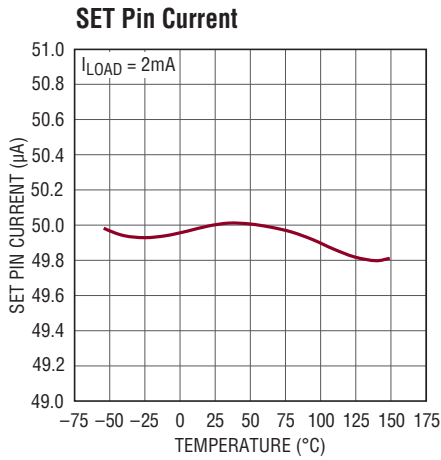

3088 G01

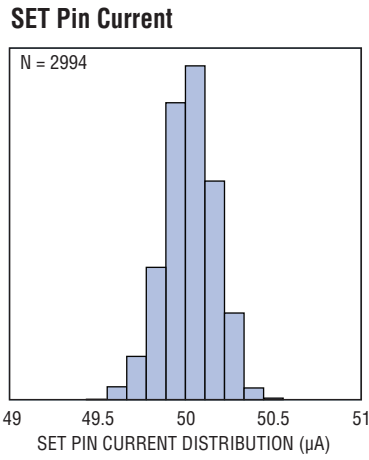

3088 G02

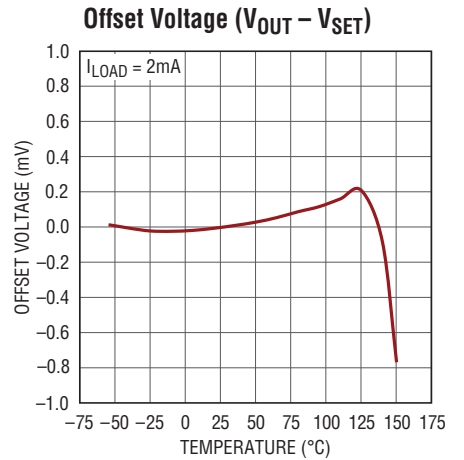

3088 G03

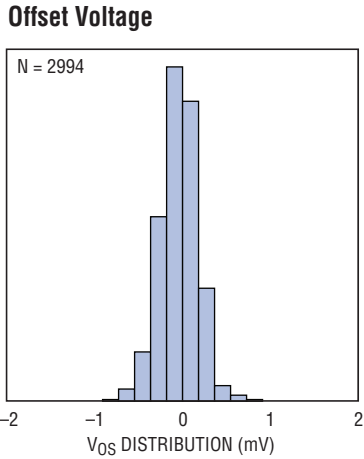

3088 G04

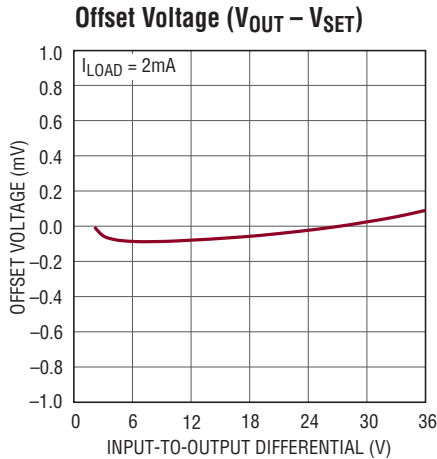

3088 G05

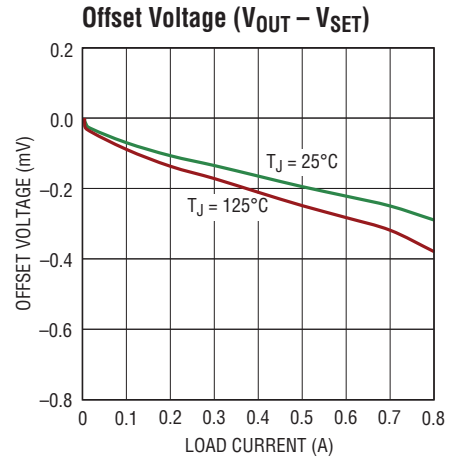

3088 G06

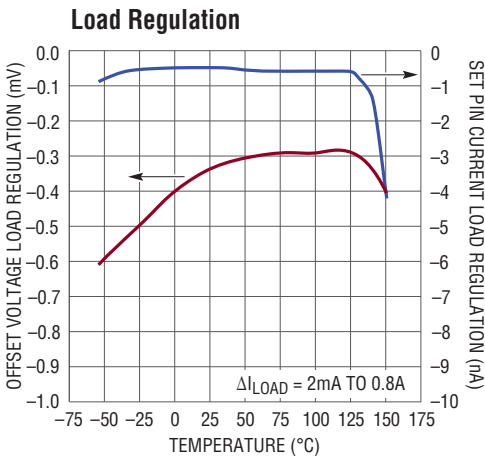

3088 G07

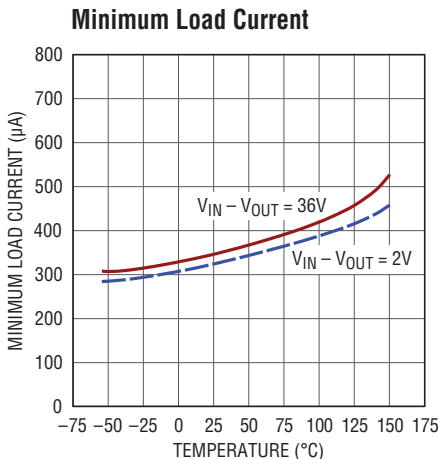

3088 G08

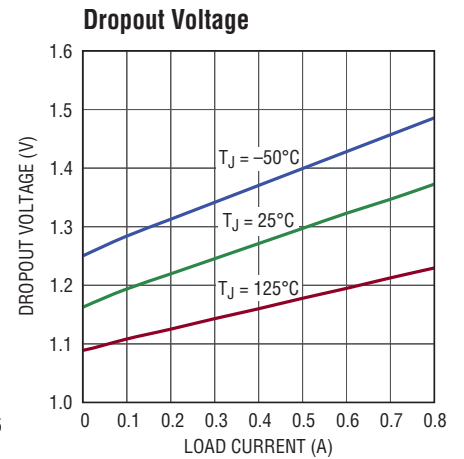

3088 G09

**TYPICAL PERFORMANCE CHARACTERISTICS**  $T_J = 25^\circ\text{C}$  unless otherwise specified.

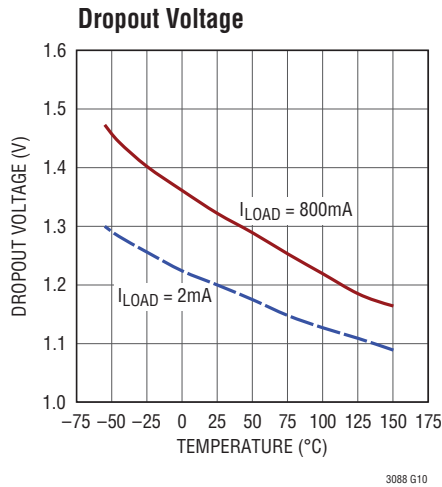

3088 G10

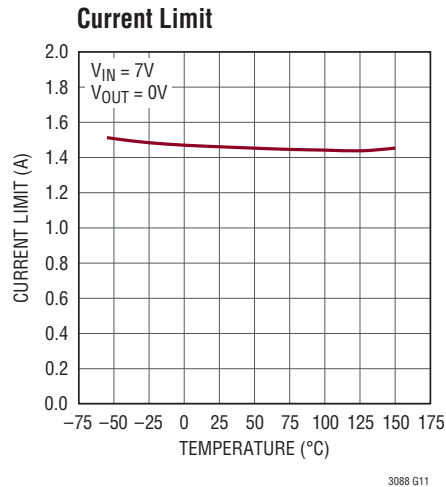

3088 G11

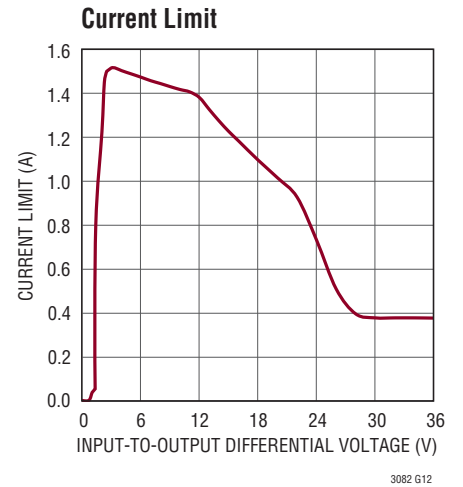

3082 G12

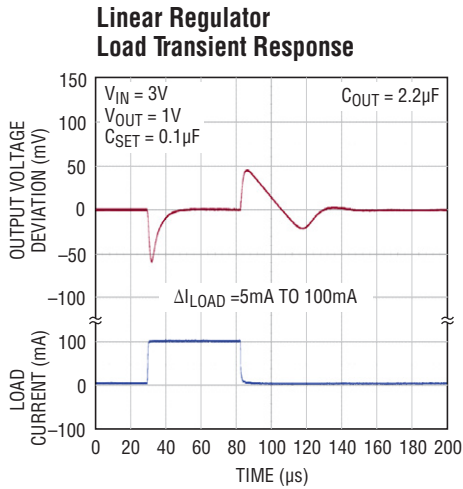

8088 G13

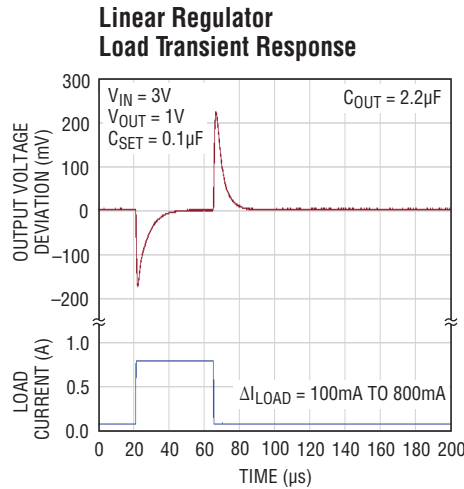

3088 G14

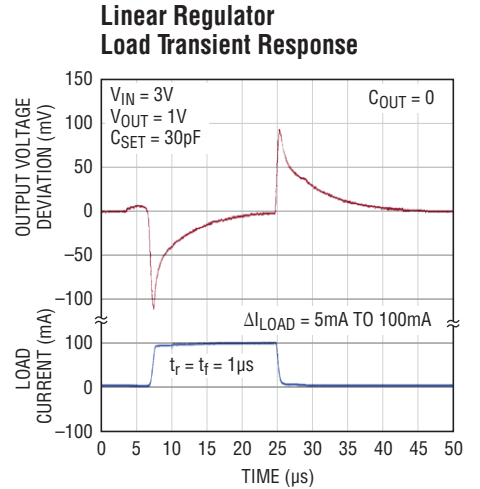

3088 G15

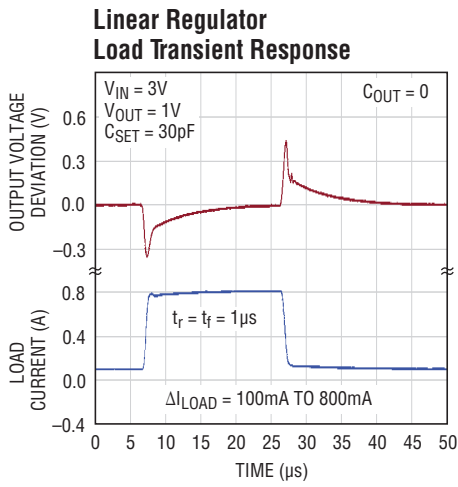

3088 G16

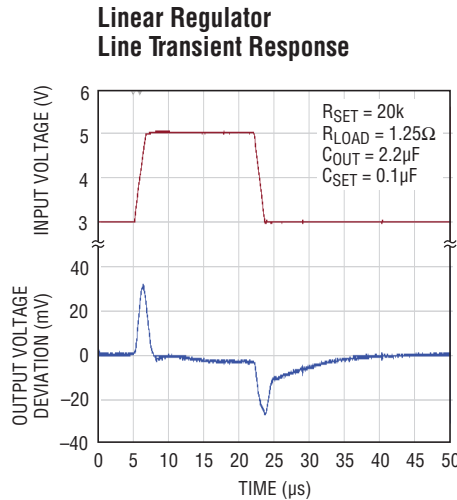

3088 G17

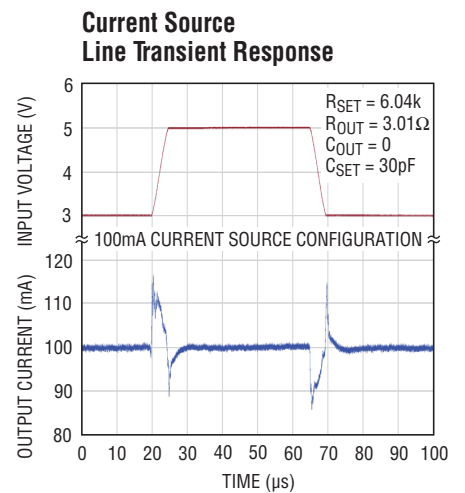

3088 G18

**TYPICAL PERFORMANCE CHARACTERISTICS**  $T_J = 25^\circ\text{C}$  unless otherwise specified.

**Current Source Line Transient Response**

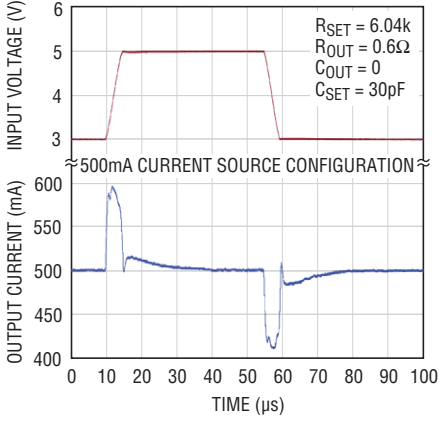

3088 G19

**Linear Regulator Turn-On Response**

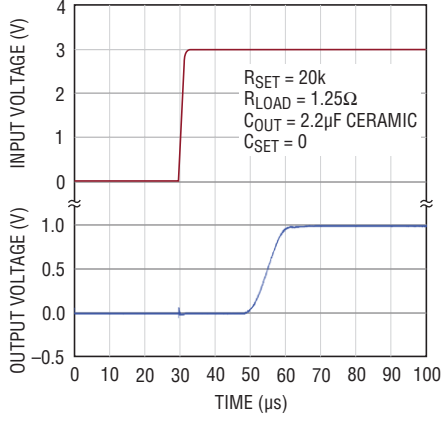

3080 G20

**Linear Regulator Turn-On Response**

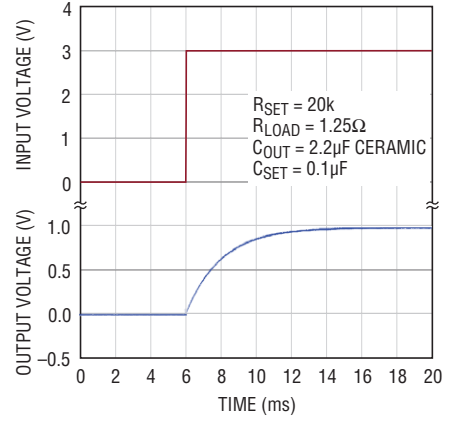

3088 G21

**Current Source Turn-On Response**

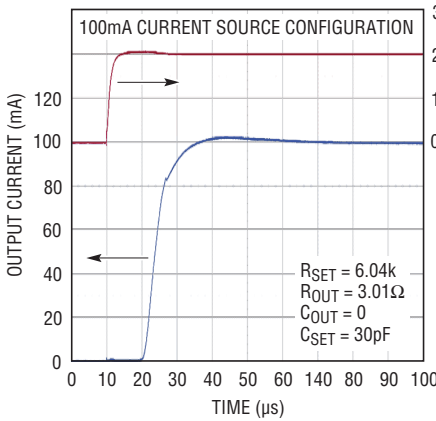

3088 G22

**Current Source Turn-On Response**

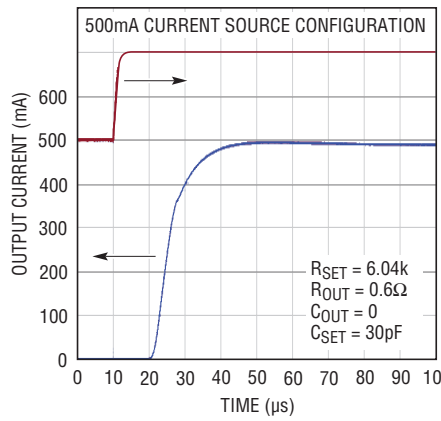

3088 G23

**Residual Output Voltage with Less Than Minimum Load**

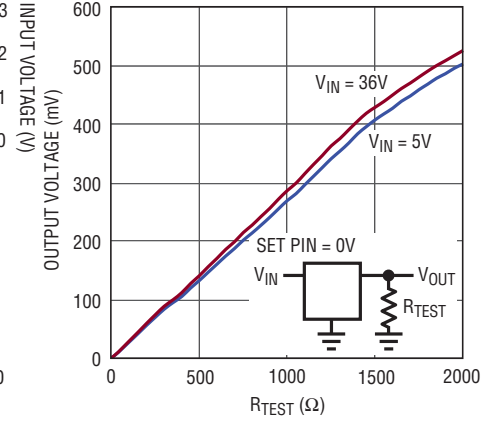

3088 G24

**Ripple Rejection**

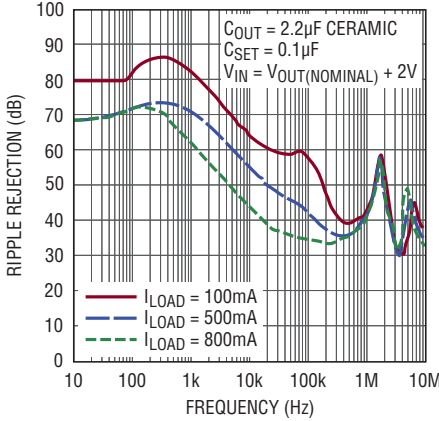

3088 G25

**Ripple Rejection**

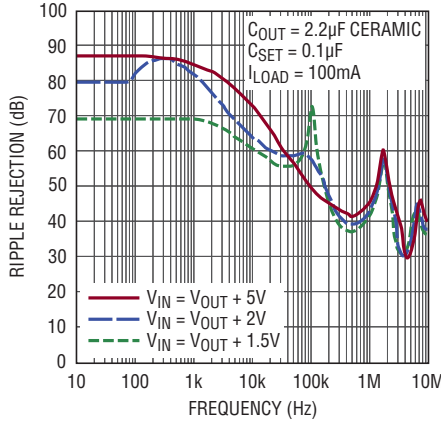

3088 G26

**Output Impedance**

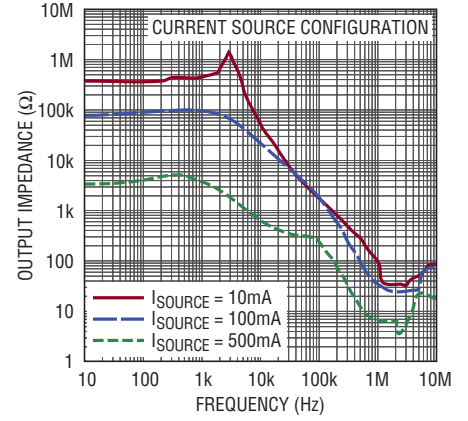

3088 G27

**TYPICAL PERFORMANCE CHARACTERISTICS**  $T_J = 25^\circ\text{C}$  unless otherwise specified.

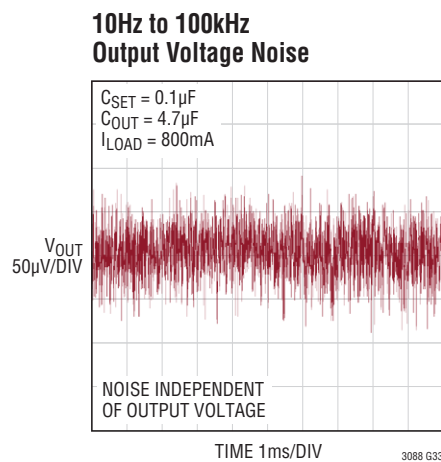
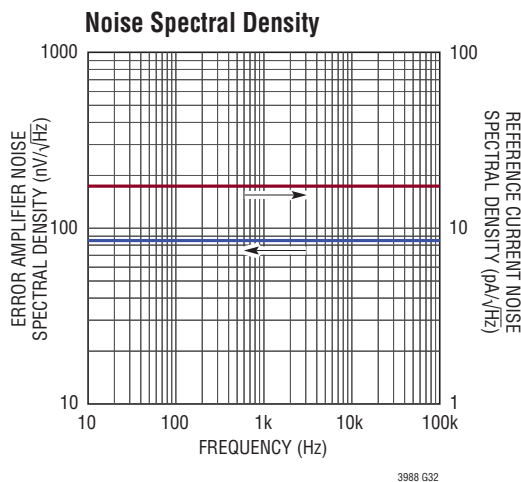
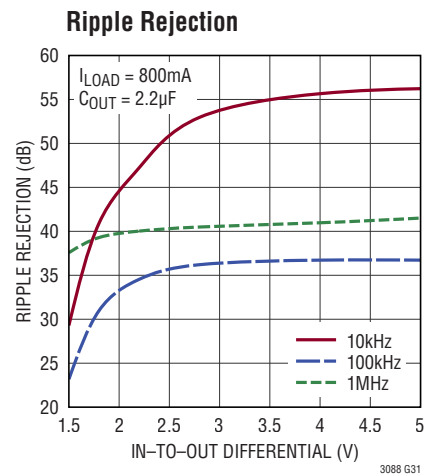
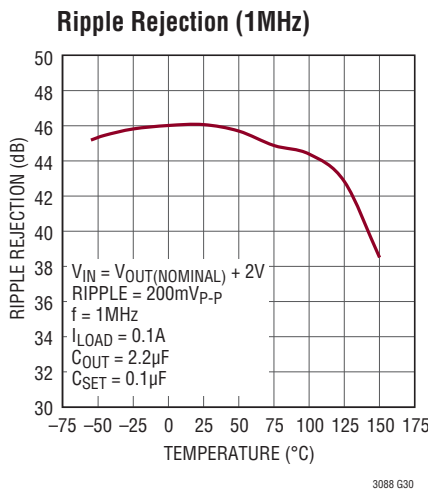
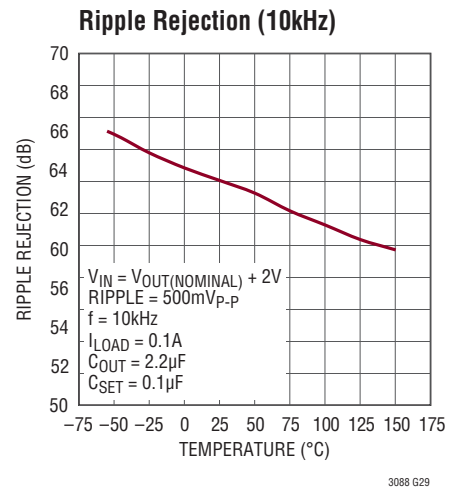
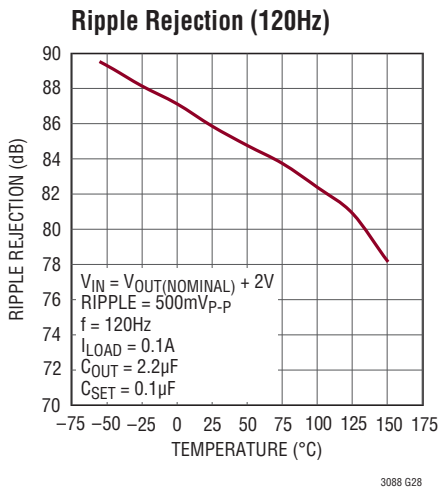

## PIN FUNCTIONS

**IN:** Input. This pin supplies power to regulate internal circuitry and supply output load current. For the device to operate properly and regulate, the voltage on this pin must be between the dropout voltage and 36V above the OUT pin (depending on output load current, see Dropout Voltage Specifications).

**OUT:** Output. This is the power output of the device. **The LT3088 requires a 2mA minimum load current for proper output regulation.**

**SET:** Set. This pin is the error amplifier's noninverting input and also sets the operating bias point of the circuit. A fixed 50 $\mu$ A current source flows out of this pin. A single external resistor programs VOUT. Output voltage range is 0V to 34.5V.

**Exposed Pad/Tab:** Output. The exposed pad of the DD package and the tab of the M and ST packages are tied internally to OUT. As such, tie them directly to OUT at the PCB. The amount of copper area and planes connected to OUT determine the effective thermal resistance of the packages.

**NC:** (DD Package Only) No Connection. No connect pins have no connection to internal circuitry and may be tied to IN, OUT, GND or floated.

---

## BLOCK DIAGRAM

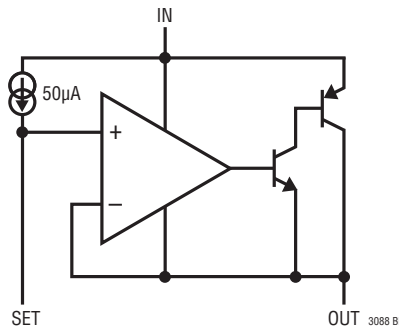

## APPLICATIONS INFORMATION

### Introduction

The LT3088 regulator is easy to use and has all the protection features expected in high performance regulators. Included are short-circuit protection, reverse-input protection and safe operating area protection, as well as thermal shutdown with hysteresis. Safe operating area (SOA) for the LT3088 is extended, allowing for use in harsh industrial and automotive environments where sudden spikes in input voltage lead to high power dissipation.

The LT3088 fits well in applications needing multiple rails. This new architecture adjusts down to zero with a single resistor, handling modern low voltage digital ICs as well as allowing easy parallel operation and thermal management without heat sinks. Adjusting to zero output allows shutting off the powered circuitry.

A precision “0” TC 50µA reference current source connects to the noninverting input of a power operational amplifier. The power operational amplifier provides a low impedance buffered output to the voltage on the noninverting input. A single resistor from the noninverting input to ground sets the output voltage. If this resistor is set to 0Ω, zero output voltage results. Therefore, any output voltage can be obtained between zero and the maximum defined by the input power supply is obtainable.

The benefit of using a true internal current source as the reference, as opposed to a bootstrapped reference in older regulators, is not so obvious in this architecture. A true reference current source allows the regulator to have gain and frequency response independent of the impedance on the positive input. On older adjustable regulators, such as the LT1086 loop gain changes with output voltage and bandwidth changes if the adjustment pin is bypassed to ground. For the LT3088, the loop gain is unchanged with output voltage changes or bypassing. Output regulation is not a fixed percentage of output voltage, but is a fixed fraction of millivolts. Use of a true current source allows all of the gain in the buffer amplifier to provide regulation, and none of that gain is needed to amplify up the reference to a higher output voltage.

### Programming Linear Regulator Output Voltage

The LT3088 generates a 50µA reference current that flows out of the SET pin. Connecting a resistor from SET to ground generates a voltage that becomes the reference point for the error amplifier (see Figure 1). The reference voltage equals 50µA multiplied by the value of the SET pin resistor (Ohm’s Law). Any voltage can be generated and there is no minimum output voltage for the regulator.

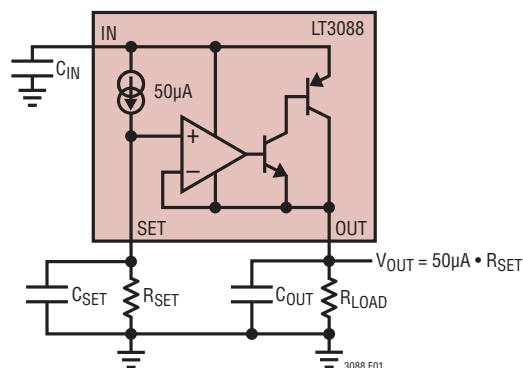

Figure 1. Basic Adjustable Regulator

Table 1 lists many common output voltages and the closest standard 1% resistor values used to generate that output voltage.

**Regulation of the output voltage requires a minimum load current of 2mA.** For true zero voltage output operation, return this 2mA load current to a negative output voltage.

Table 1. 1% Resistors for Common Output Voltages

V <sub>OUT</sub> (V)	R <sub>SET</sub> (kΩ)
1	20
1.2	24.3
1.5	30.1
1.8	35.7
2.5	49.9
3.3	66.5
5	100

## APPLICATIONS INFORMATION

With the 50µA current source used to generate the reference voltage, leakage paths to or from the SET pin can create errors in the reference and output voltages. High quality insulation should be used (e.g., Teflon, Kel-F); cleaning of all insulating surfaces to remove fluxes and other residues is required. Surface coating may be necessary to provide a moisture barrier in high humidity environments.

Minimize board leakage by encircling the SET pin and circuitry with a guard ring operated at a potential close to itself. Tie the guard ring to the OUT pin. Guarding both sides of the circuit board is required. Bulk leakage reduction depends on the guard ring width. 50nA of leakage into or out of the SET pin and its associated circuitry creates a 0.1% reference voltage error. Leakages of this magnitude, coupled with other sources of leakage, can cause significant offset voltage and reference drift, especially over the possible operating temperature range. Figure 2 depicts an example guard ring layout.

**If guard ring techniques are used, this bootstraps any stray capacitance at the SET pin. Since the SET pin is a high impedance node, unwanted signals may couple into the SET pin and cause erratic behavior. This will be most noticeable when operating with minimum output capacitors at full load current. The easiest way to remedy this is to bypass the SET pin with a small amount of capacitance from SET to ground, 10pF to 20pF is sufficient.**

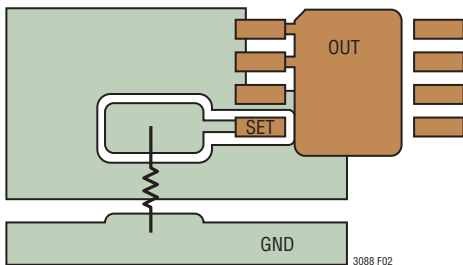

Figure 2. Guard Ring Layout Example of DD Package

### Using the LT3088 as a Replacement for the LT1117

The LT3088 can be used as an upgrade or replacement for the LT1117 regulator. The LT3088 offers superior performance over the LT1117, including extended input voltage range, lower output voltage capability, extended safe operating area, and protection features such as reverse voltage/current protection. Figure 3 shows how the LT1117 is used as a basic adjustable regulator. Two methods are shown in Figures 4 and 5 to change from the LT1117 to the LT3088. The first method (shown in Figure 4) requires no changes to existing board layouts: replace the LT1117 with the LT3088, change resistor R2 to set the desired output voltage, and do not stuff resistor R1 (the minimum load requirement of 2mA for the LT3088 must still be met). The second method is shown in Figure 5: a 25k resistor is

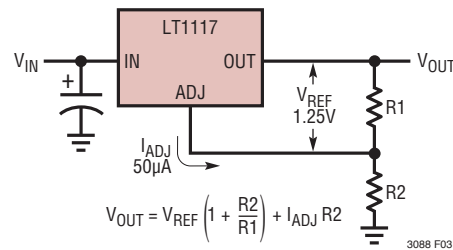

Figure 3. LT1117 Basic Adjustable Regulator

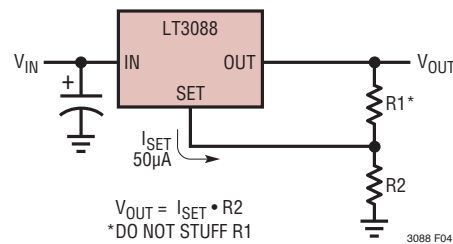

Figure 4. Upgrade to LT3088 Requires No Layout Changes

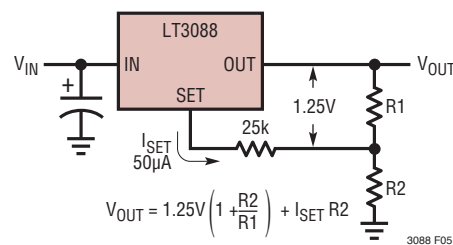

Figure 5. Resistor in Series with SET Pin Matches LT1117 Operation

added in series with the SET pin of the LT3088 and uses the same existing resistor divider. This technique can be used to easily satisfy the LT3088's 2mA minimum load current requirement.

### Configuring the LT3088 as a Current Source

Setting the LT3088 to operate as a 2-terminal current source is a simple matter. The 50µA reference current from the SET pin is used with one resistor to generate a small voltage, usually in the range of 100mV to 1V (200mV is a level that rejects offset voltage, line regulation, and other errors without being excessively large). This voltage is then applied across a second resistor that connects from OUT to the first resistor. Figure 6 shows connections and formulas to calculate a basic current source configuration.

Again, the lower current levels used in the LT3088 necessitate attention to board leakages as error sources (see the Programming Linear Regulator Output Voltage section).

### Selecting R<sub>SET</sub> and R<sub>OUT</sub> in Current Source Applications

In Figure 6, both resistors R<sub>SET</sub> and R<sub>OUT</sub> program the value of the output current. The question now arises: the ratio of these resistors is known, but what value should each resistor be?

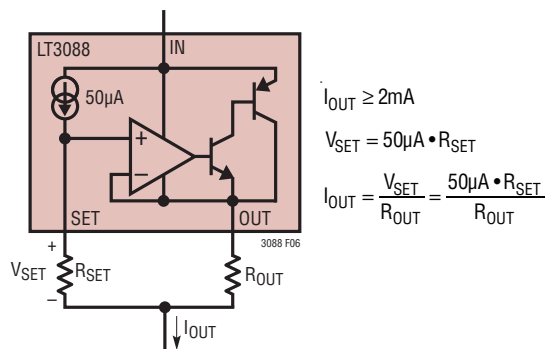

Figure 6. Using the LT3088 as a Current Source

The first resistor to select is R<sub>SET</sub>. The value selected should generate enough voltage to minimize the error caused by the offset between the SET and OUT pins. A reasonable starting level is ~200mV of voltage across R<sub>SET</sub> (R<sub>SET</sub> equal to 4.02k). Resultant errors due to offset voltage are a few percent. The lower the voltage across R<sub>SET</sub> becomes, the higher the error term due to the offset.

From this point, selecting R<sub>OUT</sub> is easy, as it is a straightforward calculation from R<sub>SET</sub>. Take note, however, resistor errors must be accounted for as well. While larger voltage drops across R<sub>SET</sub> minimize the error due to offset, they also increase the required operating headroom.

Obtaining the best temperature coefficient does not require the use of expensive resistors with low ppm temperature coefficients. Instead, since the output current of the LT3088 is determined by the ratio of R<sub>SET</sub> to R<sub>OUT</sub>, those resistors should have matching temperature characteristics. Less expensive resistors made from the same material provide matching temperature coefficients. See resistor manufacturers' data sheets for more details.

Higher output currents necessitate the use of higher wattage resistors for R<sub>OUT</sub>. There may be a difference between the resistors used for R<sub>OUT</sub> and R<sub>SET</sub>. A better method to maintain consistency in resistors is to use multiple resistors in parallel to create R<sub>OUT</sub>, allowing the same wattage and type of resistor as R<sub>SET</sub>.

### Stability and Input Capacitance

The LT3088 does not require an input capacitor to maintain stability. Input capacitors are recommended in linear regulator configurations to provide a low impedance input source to the LT3088. If using an input capacitor, low ESR, ceramic input bypass capacitors are acceptable for applications without long input leads. However, applications connecting a power supply to an LT3088 circuit's IN and GND pins with long input wires combined with low ESR, ceramic input capacitors are prone to voltage spikes, reliability concerns and application-specific board oscillations. The input wire inductance found in many

battery-powered applications, combined with the low ESR ceramic input capacitor, forms a high Q LC resonant tank circuit. In some instances this resonant frequency beats against the output current dependent LDO bandwidth and interferes with proper operation. Simple circuit modifications/solutions are then required. This behavior is not indicative of LT3088 instability, but is a common ceramic input bypass capacitor application issue.

The self-inductance, or isolated inductance, of a wire is directly proportional to its length. Wire diameter is not a major factor on its self-inductance. For example, the self-inductance of a 2-AWG isolated wire (diameter = 0.26") is about half the self-inductance of a 30-AWG wire (diameter = 0.01"). One foot of 30-AWG wire has about 465nH of self inductance.

One of two ways reduces a wire's self-inductance. One method divides the current flowing towards the LT3088 between two parallel conductors. In this case, the farther apart the wires are from each other, the more the self-inductance is reduced; up to a 50% reduction when placed a few inches apart. Splitting the wires basically connects two equal inductors in parallel, but placing them in close proximity gives the wires mutual inductance adding to the self-inductance. The second and most effective way to reduce overall inductance is to place both forward and return current conductors (the input and GND wires) in very close proximity. Two 30-AWG wires separated by only 0.02", used as forward and return current conductors, reduce the overall self-inductance to approximately one-fifth that of a single isolated wire.

If wiring modifications are not permissible for the applications, including series resistance between the power supply and the input of the LT3088 also stabilizes the application. As little as 0.1 $\Omega$  to 0.5 $\Omega$ , often less, is effective in damping the LC resonance. If the added impedance between the power supply and the input is unacceptable, adding ESR to the input capacitor also provides the necessary damping of the LC resonance. However, the required ESR is generally higher than the series impedance required.

## Stability and Frequency Compensation for Linear Regulator Configurations

The LT3088 does not require an output capacitor for stability. LTC recommends an output capacitor of 10 $\mu$ F with an ESR of 0.5 $\Omega$  or less to provide good transient performance in linear regulator configurations. Larger values of output capacitance decrease peak deviations and provide improved transient response for larger load current changes. Bypass capacitors, used to decouple individual components powered by the LT3088, increase the effective output capacitor value. For improvement in transient performance, place a capacitor across the voltage setting resistor. Capacitors up to 1 $\mu$ F can be used. This bypass capacitor reduces system noise as well, but start-up time is proportional to the time constant of the voltage setting resistor ( $R_{SET}$  in Figure 1) and SET pin bypass capacitor.

## Stability and Frequency Compensation for Current Source Configurations

The LT3088 does not require input or output capacitors for stability in many current-source applications. Clean, tight PCB layouts provide a low reactance, well controlled operating environment for the LT3088 without requiring capacitors to frequency compensate the circuit. Figure 6 highlights the simplicity of using the LT3088 as a current source.

Some current source applications use a capacitor connected in parallel with the SET pin resistor to lower the current source's noise. This capacitor also provides a soft-start function for the current source. See Quieting the Noise section for further details. When operating without output capacitors, the high impedance nature of the SET pin as the input of the error amplifier allows signal from the output to couple in, showing as high frequency ringing during transients. Bypassing the SET resistor with a capacitor in the range of 20pF to 30pF dampens the ringing.

Depending on the pole introduced by a capacitor or other complex impedances presented to the LT3088, external

## APPLICATIONS INFORMATION

compensation may be required for stability. Techniques are discussed to achieve this in the following paragraphs. Linear Technology strongly recommends testing stability in situ with final components before beginning production.

Although the LT3088's design strives to be stable without capacitors over a wide variety of operating conditions, it is not possible to test for all possible combinations of input and output impedances that the LT3088 will encounter. These impedances may include resistive, capacitive, and inductive components and may be complex distributed networks. In addition, the current source's value will differ between applications and its connection may be GND referenced, power supply referenced, or floating in a signal line path. Linear Technology strongly recommends that stability be tested in situ for any LT3088 application.

In LT3088 applications with long wires or PCB traces, the inductive reactance may cause instability. In some cases, adding series resistance to the input and output lines (as

shown in Figure 7) may sufficiently dampen these possible high-Q lines and provide stability. The user must evaluate the required resistor values against the design's headroom constraints. In general, operation at low output current levels (<20mA) automatically requires higher values of programming resistors and may provide the necessary damping without additional series impedance.

If the line impedances in series with the LT3088 are complex enough such that series damping resistors are not sufficient, a frequency compensation network may be necessary. Several options may be considered.

Figure 8 depicts the simplest frequency compensation networks as a single capacitor across the two terminals of the current source. Some applications may use the capacitance to stand off DC voltage but allow the transfer of data down a signal line.

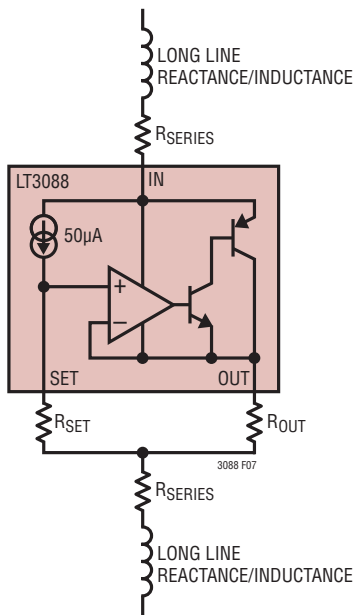

**Figure 7. Adding Series Resistance Decouples and Dampens Long Line Reactances**

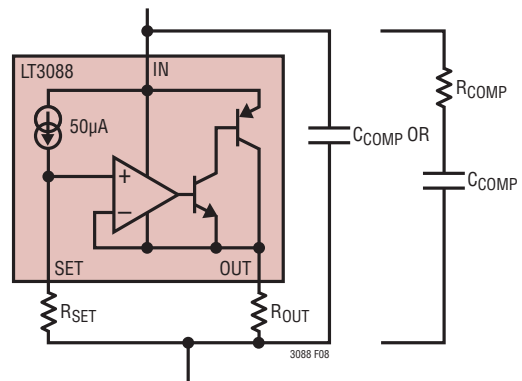

**Figure 8. Compensation from Input to Output of Current Source Provides Stability**

For some applications, pure capacitance may be unacceptable or present a design constraint. One circuit example typifying this is an “intrinsically-safe” circuit in which an overload or fault condition potentially allows the capacitor's stored energy to create a spark or arc. For applications where a single capacitor is unacceptable, Figure 8 alternately shows a series RC network connected across the two terminals of the current source. This network has the added benefit of limiting the discharge current of the

## APPLICATIONS INFORMATION

capacitor under a fault condition, preventing sparks or arcs. In many instances, a series RC network is the best solution for stabilizing the application circuit. Typical resistor values will range from  $100\Omega$  to  $5k$ . Once again, Linear Technology strongly recommends testing stability in situ for any LT3088 application across all operating conditions, especially ones that present complex impedance networks at the input and output of the current source.

If an application refers the bottom of the LT3088 current source to GND, it may be necessary to bypass the top of the current source with a capacitor to GND. In some cases, this capacitor may already exist and no additional capacitance is required. For example, if the LT3088 is used as a variable current source on the output of a power supply, the output bypass capacitance would suffice to provide LT3088 stability. Other applications may require the addition of a bypass capacitor. A series RC network may also be used as necessary, and depends on the application requirements.

In some extreme cases, capacitors or series RC networks may be required on both the LT3088's input and output to stabilize the circuit. Figure 9 depicts a general application using input and output capacitor networks rather than an input-to-output capacitor. As the input of the current source tends to be high impedance, placing a capacitor on the input does not have the same effect as placing a capacitor on the lower impedance output. Capacitors in the range of  $0.1\mu\text{F}$  to  $1\mu\text{F}$  usually provide sufficient bypassing on the input, and the value of input capacitance may be increased without limit. Pay careful attention to using low ESR input capacitors with long input lines (see the Stability and Input Capacitance section for more information).

### Using Ceramic Capacitors

Give extra consideration to the use of ceramic capacitors. Ceramic capacitors are manufactured with a variety of dielectrics, each with different behavior across temperature and applied voltage. The most common dielectrics used

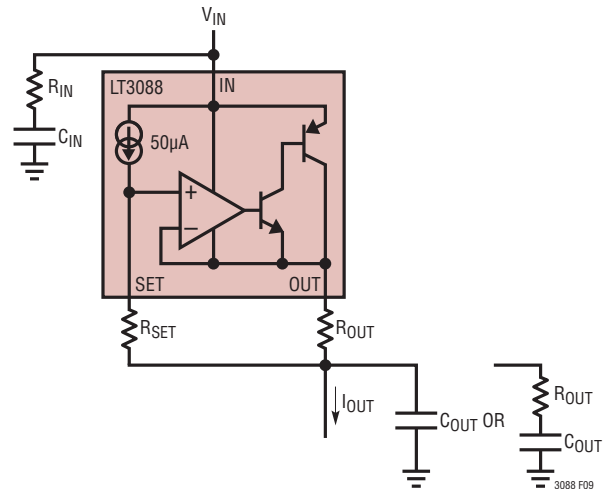

**Figure 9. Input and/or Output Capacitors May Be Used for Compensation**

are specified with EIA temperature characteristic codes of Z5U, Y5V, X5R and X7R. The Z5U and Y5V dielectrics are good for providing high capacitances in a small package, but they tend to have strong voltage and temperature coefficients as shown in Figures 10 and 11. When used with a 5V regulator, a 16V  $10\mu\text{F}$  Y5V capacitor can exhibit an effective value as low as  $1\mu\text{F}$  to  $2\mu\text{F}$  for the DC bias voltage applied and over the operating temperature range. The X5R and X7R dielectrics result in more stable characteristics and are more suitable for use as the output capacitor. The X7R type has better stability across temperature, while the X5R is less expensive and is available in higher values. Care still must be exercised when using X5R and X7R capacitors. The X5R and X7R codes only specify operating temperature range and maximum capacitance change over temperature. Capacitance change due to DC bias with X5R and X7R capacitors is better than Y5V and Z5U capacitors, but can still be significant enough to drop capacitor values below appropriate levels. Capacitor DC bias characteristics tend to improve as component case size increases, but expected capacitance at operating voltage should be verified.

## APPLICATIONS INFORMATION

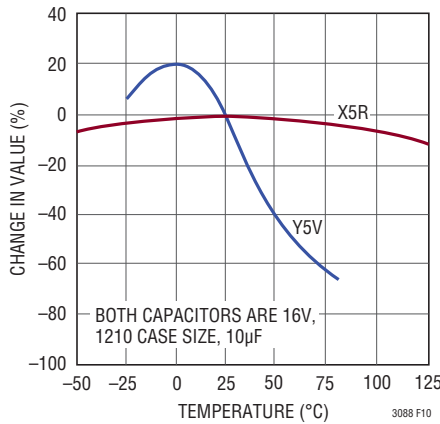

Figure 10. Ceramic Capacitor Temperature Characteristics

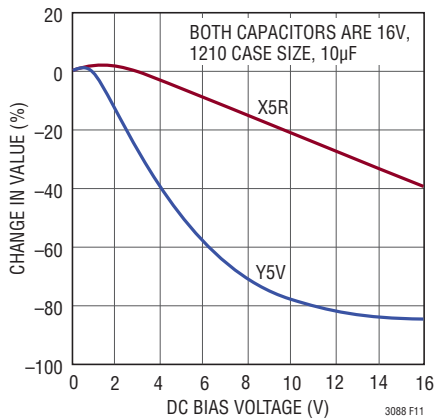

Figure 11. Ceramic Capacitor DC Bias Characteristics

Voltage and temperature coefficients are not the only sources of problems. Some ceramic capacitors have a piezoelectric response. A piezoelectric device generates voltage across its terminals due to mechanical stress. In a ceramic capacitor, the stress can be induced by vibrations in the system or thermal transients.

### Paralleling Devices

Higher output current is obtained by paralleling multiple LT3088s together. Tie the individual SET pins together and tie the individual IN pins together. Connect the outputs in common using small pieces of PC trace as ballast resistors

to promote equal current sharing. PC trace resistance in milliohms/inch is shown in Table 2. Ballasting requires only a tiny area on the PCB.

Table 2. PC Board Trace Resistance

WEIGHT (oz)	10mil WIDTH	20mil WIDTH
1	54.3	27.1
2	27.1	13.6

Trace resistance is measured in mΩ/in.

The worst-case room temperature offset, only ±1.5mV between the SET pin and the OUT pin, allows the use of very small ballast resistors.

As shown in Figure 12, each LT3088 has a small 10mΩ ballast resistor, which at full output current gives better than 80% equalized sharing of the current. The external resistance of 10mΩ (5mΩ for the two devices in parallel) only adds about 8mV of output regulation drop at an output of 1.6A. Even with an output voltage as low as 1V, this only adds 0.8% to the regulation. Of course, paralleling more than two LT3088s yields even higher output current. Spreading the devices on the PC board also spreads the heat. Series input resistors can further spread the heat if the input-to-output difference is high.

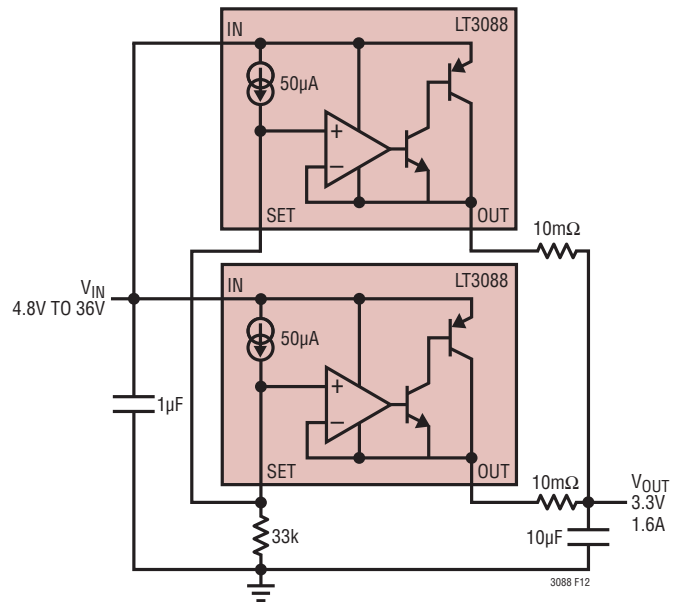

Figure 12. Parallel Devices

## APPLICATIONS INFORMATION

### Quieting the Noise

The LT3088 offers numerous noise performance advantages. Every linear regulator has its sources of noise. In general, a linear regulator's critical noise source is the reference. In addition, consider the error amplifier's noise contribution along with the resistor divider's noise gain.

Many traditional low noise regulators bond out the voltage reference to an external pin (usually through a large value resistor) to allow for bypassing and noise reduction. The LT3088 does not use a traditional voltage reference like other linear regulators. Instead, it uses a 50 $\mu$ A reference current. The 50 $\mu$ A current source generates noise current levels of 18pA/ $\sqrt{\text{Hz}}$  (5.7nA<sub>RMS</sub> over a 10Hz to 100kHz bandwidth). The equivalent voltage noise equals the RMS noise current multiplied by the resistor value.

The SET pin resistor generates spot noise equal to  $\sqrt{4kTR}$  ( $k$  = Boltzmann's constant,  $1.38 \cdot 10^{-23} \text{ J/}^\circ\text{K}$ , and  $T$  is absolute temperature) which is RMS summed with the voltage noise. If the application requires lower noise performance, bypass the voltage setting resistor with a capacitor to GND. Note that this noise-reduction capacitor increases start-up time as a factor of the RC time constant.

The LT3088 uses a unity-gain follower from the SET pin to the OUT pin. Therefore, multiple possibilities exist (besides a SET pin resistor) to set output voltage. For example, using a high accuracy voltage reference from SET to GND removes the errors in output voltage due to reference current tolerance and resistor tolerance. Active driving of the SET pin is acceptable.

The typical noise scenario for a linear regulator is that the output voltage setting resistor divider gains up the reference noise, especially if  $V_{\text{OUT}}$  is much greater than  $V_{\text{REF}}$ . The LT3088's noise advantage is that the unity-gain follower presents no noise gain whatsoever from the SET pin to the output. Thus, noise figures do not increase accordingly. Error amplifier noise is typical 85nV/ $\sqrt{\text{Hz}}$  (27 $\mu$ V<sub>RMS</sub> over a 10Hz to 100kHz bandwidth). The error amplifier's noise is RMS summed with the other noise terms to give a final noise figure for the regulator.

Paralleling of regulators adds the benefit that output noise is reduced. For  $n$  regulators in parallel, the output noise drops by a factor of  $\sqrt{n}$ .

Curves in the Typical Performance Characteristics section show noise spectral density and peak-to-peak noise characteristics for both the reference current and error amplifier over a 10Hz to 100kHz bandwidth.

### Load Voltage Regulation

The LT3088 is a floating device. No ground pin exists on the packages. Thus, the IC delivers all quiescent current and drive current to the load. Therefore, it is not possible to provide true remote load sensing. The connection resistance between the regulator and the load determines load regulation performance. The data sheet's load regulation specification is Kelvin sensed at the package's pins. Negative-side sensing is a true Kelvin connection by returning the bottom of the voltage setting resistor to the negative side of the load (see Figure 13).

Connected as shown, system load regulation is the sum of the LT3088's load regulation and the parasitic line resistance multiplied by the output current. To minimize load regulation, keep the positive connection between the regulator and load as short as possible. If possible, use large diameter wire or wide PC board traces.

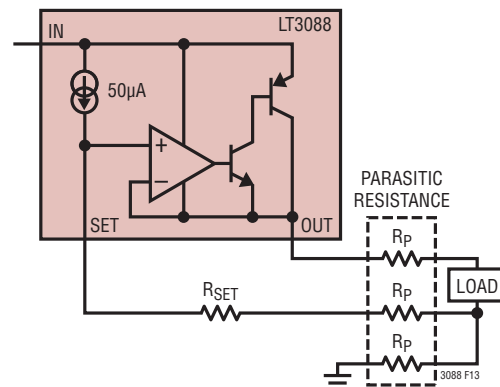

Figure 13. Connections for Best Load Regulation

## APPLICATIONS INFORMATION

### Thermal Considerations

The LT3088's internal power and thermal limiting circuitry protects itself under overload conditions. For continuous normal load conditions, do not exceed the 125°C (E- and I-grades) or 150°C (H- and MP-grades) maximum junction temperature. Carefully consider all sources of thermal resistance from junction-to-ambient. This includes (but is not limited to) junction-to-case, case-to-heat sink interface, heat sink resistance or circuit board-to-ambient as the application dictates. Consider all additional, adjacent heat generating sources in proximity on the PCB.

Surface mount packages provide the necessary heat sinking by using the heat spreading capabilities of the PC board, copper traces and planes. Surface mount heat sinks, plated through-holes and solder-filled vias can also spread the heat generated by power devices.

Junction-to-case thermal resistance is specified from the IC junction to the bottom of the case directly, or the bottom of the pin most directly in the heat path. This is the lowest thermal resistance path for heat flow. Only proper device mounting ensures the best possible thermal flow from this area of the packages to the heat sinking material.

**Note that the exposed pad of the DFN package and the tab of the DD-Pak and SOT-223 packages are electrically connected to the output ( $V_{OUT}$ ).**

Tables 3 through 5 list thermal resistance as a function of copper areas on a fixed board size. All measurements were taken in still air on a 4-layer FR-4 board with 1oz solid internal planes and 2oz external trace planes with a total finished board thickness of 1.6mm.

**Table 3. DD Package, 8-Lead DFN**

COPPER AREA		BOARD AREA	THERMAL RESISTANCE (JUNCTION-TO-AMBIENT)
TOPSIDE*	BACKSIDE		
2500mm <sup>2</sup>	2500mm <sup>2</sup>	2500mm <sup>2</sup>	26°C/W
1000mm <sup>2</sup>	2500mm <sup>2</sup>	2500mm <sup>2</sup>	26°C/W
225mm <sup>2</sup>	2500mm <sup>2</sup>	2500mm <sup>2</sup>	28°C/W
100mm <sup>2</sup>	2500mm <sup>2</sup>	2500mm <sup>2</sup>	31°C/W

\*Device is mounted on top side

**Table 4. ST Package, 3-Lead SOT-223**

COPPER AREA		BOARD AREA	THERMAL RESISTANCE (JUNCTION-TO-AMBIENT)
TOPSIDE*	BACKSIDE		
2500mm <sup>2</sup>	2500mm <sup>2</sup>	2500mm <sup>2</sup>	23°C/W
1000mm <sup>2</sup>	2500mm <sup>2</sup>	2500mm <sup>2</sup>	23°C/W
225mm <sup>2</sup>	2500mm <sup>2</sup>	2500mm <sup>2</sup>	25°C/W
100mm <sup>2</sup>	2500mm <sup>2</sup>	2500mm <sup>2</sup>	27°C/W

\*Device is mounted on top side

**Table 5. M Package, 3-Lead DD-Pak**

COPPER AREA		BOARD AREA	THERMAL RESISTANCE (JUNCTION-TO-AMBIENT)
TOPSIDE*	BACKSIDE		
2500mm <sup>2</sup>	2500mm <sup>2</sup>	2500mm <sup>2</sup>	13°C/W
1000mm <sup>2</sup>	2500mm <sup>2</sup>	2500mm <sup>2</sup>	14°C/W
225mm <sup>2</sup>	2500mm <sup>2</sup>	2500mm <sup>2</sup>	16°C/W

\*Device is mounted on top side

For further information on thermal resistance and using thermal information, refer to JEDEC standard JESD51, notably JESD51-12.

PCB layers, copper weight, board layout and thermal vias affect the resultant thermal resistance. Tables 3 through 5 provide thermal resistance numbers for best-case 4-layer boards with 1oz internal and 2oz external copper. Modern, multilayer PCBs may not be able to achieve quite the same

## APPLICATIONS INFORMATION

level performance as found in these tables. Demo circuit DC2279A's board layout using multiple inner  $V_{OUT}$  planes and multiple thermal vias achieves 18°C/W performance for the DD package.

### Calculating Junction Temperature

Example: Given an output voltage of 0.9V, an IN voltage of 2.5V  $\pm 5\%$ , output current range from 10mA to 0.5A and a maximum ambient temperature of 50°C, what is the maximum junction temperature for the DD-Pak on a 2500mm<sup>2</sup> board with topside copper of 1000mm<sup>2</sup>?

The power in the circuit equals:

$$P_{TOTAL} = (V_{IN} - V_{OUT})(I_{OUT})$$

The current delivered to the SET pin is negligible and can be ignored.

$$V_{IN(MAX\_CONTINUOUS)} = 2.625V (2.5V + 5\%)$$

$$V_{OUT} = 0.9V, I_{OUT} = 0.5A, T_A = 50^\circ C$$

Power dissipation under these conditions equals:

$$P_{TOTAL} = (V_{IN} - V_{OUT})(I_{OUT})$$

$$P_{TOTAL} = (2.625V - 0.9V)(0.5A) = 0.87W$$

Junction Temperature equals:

$$T_J = T_A + P_{TOTAL} \cdot \theta_{JA} \text{ (using tables)}$$

$$T_J = 50^\circ C + 0.87W \cdot 14^\circ C/W = 62^\circ C$$

In this case, the junction temperature is below the maximum rating, ensuring reliable operation.

### Reducing Power Dissipation

In some applications it may be necessary to reduce the power dissipation in the LT3088 package without sacrificing output current capability. Two techniques are available. The first technique, illustrated in Figure 14, employs a resistor in series with the regulator's input. The voltage drop across  $R_S$  decreases the LT3088's IN-to-OUT differential voltage and correspondingly decreases the LT3088's power dissipation.

As an example, assume:  $V_{IN} = 7V$ ,  $V_{OUT} = 3.3V$  and  $I_{OUT(MAX)} = 0.8A$ . Use the formulas from the Calculating Junction Temperature section previously discussed.

Without series resistor  $R_S$ , power dissipation in the LT3088 equals:

$$P_{TOTAL} = (7V - 3.3V) \cdot 0.8A = 2.96W$$

If the voltage differential ( $V_{DIFF}$ ) across the LT3088 is chosen as 1.5V, then  $R_S$  equals:

$$R_S = \frac{7V - 3.3V - 1.5V}{0.8A} = 2.75\Omega$$

Power dissipation in the LT3088 now equals:

$$P_{TOTAL} = 1.5V \cdot 0.8A = 1.2W$$

The LT3088's power dissipation is now only 40% compared to no series resistor.  $R_S$  dissipates 1.75W of power. Choose appropriate wattage resistors or use multiple resistors in parallel to handle and dissipate the power properly.

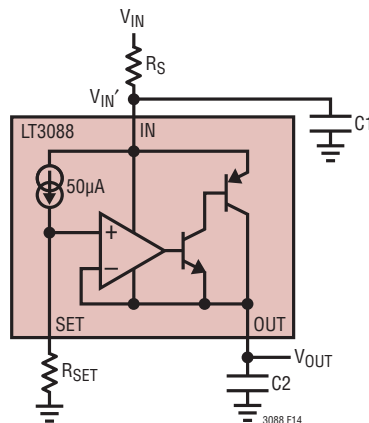

Figure 14. Reducing Power Dissipation Using a Series Resistor

## APPLICATIONS INFORMATION

The second technique for reducing power dissipation, shown in Figure 15, uses a resistor in parallel with the LT3088. This resistor provides a parallel path for current flow, reducing the current flowing through the LT3088. This technique works well if input voltage is reasonably constant and output load current changes are small. This technique also increases the maximum available output current at the expense of minimum load requirements.

As an example, assume:  $V_{IN} = 5V$ ,  $V_{IN(MAX)} = 5.5V$ ,  $V_{OUT} = 3.3V$ ,  $V_{OUT(MIN)} = 3.2V$ ,  $I_{OUT(MAX)} = 0.8A$  and  $I_{OUT(MIN)} = 0.3A$ . Also, assuming that  $R_P$  carries no more than 90% of  $I_{OUT(MIN)} = 270mA$ .

Calculating  $R_P$  yields:

$$R_P = \frac{5.5V - 3.2V}{0.27A} = 8.52\Omega$$

(5% Standard value = 9.1 $\Omega$ )

The maximum total power dissipation is:

$$(5.5V - 3.2V) \cdot 0.8A = 1.84W$$

However, the LT3088 supplies only:

$$0.8A - \frac{5.5V - 3.2V}{9.1\Omega} = 0.55A$$

Therefore, the LT3088's power dissipation is only:

$$P_{DISS} = (5.5V - 3.2V) \cdot 0.55A = 1.26W$$

$R_P$  dissipates 0.58W of power. As with the first technique, choose appropriate wattage resistors to handle and dissipate the power properly. With this configuration, the LT3088 supplies only 0.55A. Therefore, load current can increase by 0.25A to a total output current of 1.05A while keeping the LT3088 in its normal operating range.

### High Temperature Operation

Care must be taken when designing the LT3088H/LT3088MP applications to operate at high ambient temperatures. The LT3088H/LT3088MP operates at high temperatures, but erratic operation can occur due to unforeseen variations in external components. Some tantalum capacitors are available for high temperature operation, but ESR is often several ohms; capacitor ESR above 0.5 $\Omega$  is unsuitable for use with the LT3088H/LT3088MP. Multiple ceramic capacitor manufacturers now offer ceramic capacitors that are rated to 150 $^{\circ}C$  using an X8R dielectric. Check each passive component for absolute value and voltage ratings over the operating temperature range.

Leakages in capacitors or from solder flux left after insufficient board cleaning adversely affects low current nodes, such as the SET pins. Consider junction temperature increase due to power dissipation in both the junction and nearby components to ensure maximum specifications are not violated for the LT3088H/LT3088MP or external components.

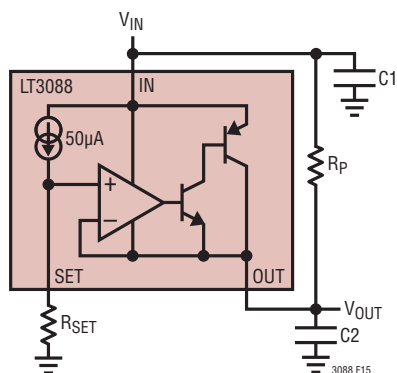

Figure 15. Reducing Power Dissipation Using a Parallel Resistor

## APPLICATIONS INFORMATION

### Protection Features

The LT3088 incorporates several protection features ideal for harsh industrial and automotive environments, among other applications. In addition to normal monolithic regulator protection features such as current limiting and thermal limiting, the LT3088 protects itself against reverse-input voltages, reverse-output voltages, and large OUT-to-SET pin voltages.

Current limit protection and thermal overload protection protect the IC against output current overload conditions. For normal operation, do not exceed the rated absolute maximum junction temperature. The thermal shutdown circuit's temperature threshold is typically 165°C and incorporates about 5°C of hysteresis.

The LT3088's IN pin withstands  $\pm 40\text{V}$  voltages with respect to the OUT and SET pins. Reverse current flow, if OUT is greater than IN, is less than 1mA (typically under 100 $\mu\text{A}$ ), protecting the LT3088 and sensitive loads.

Clamping diodes and 400 $\Omega$  limiting resistors protect the LT3088's SET pin relative to the OUT pin voltage. These protection components typically only carry current under transient overload conditions. These devices are sized to handle  $\pm 10\text{V}$  differential voltages and  $\pm 25\text{mA}$  crosspin current flow without damage. Relative to these application concerns, note the following two scenarios. The first scenario employs a noise-reducing SET pin bypass capacitor while OUT is instantaneously shorted to GND. The second scenario follows improper shutdown techniques in which the SET pin is reset to GND quickly while OUT is held up by a large output capacitance with light load. During normal operation, keep OUT-to-SET differential voltages below 2V.

## TYPICAL APPLICATIONS

### Paralleling Regulators

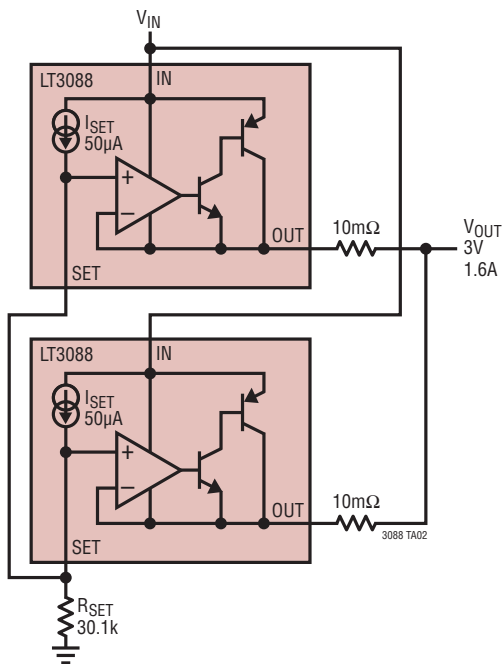

### Boosting Fixed Output Regulators

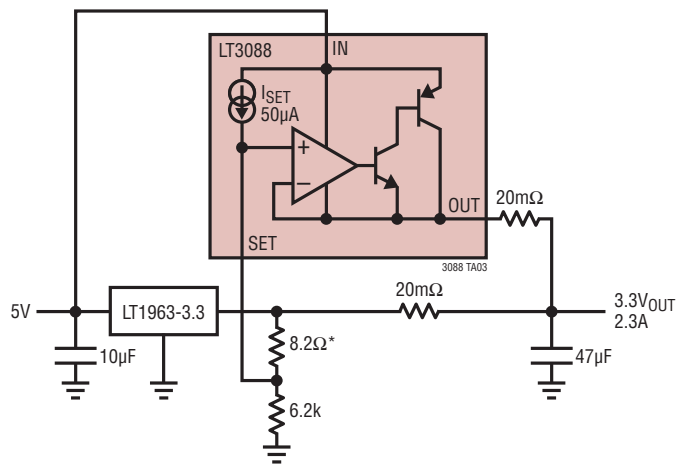

\*4mV DROP ENSURES LT3088 IS OFF WITH NO LOAD  
MULTIPLE LT3088s CAN BE USED

# TYPICAL APPLICATIONS

Reference Buffer

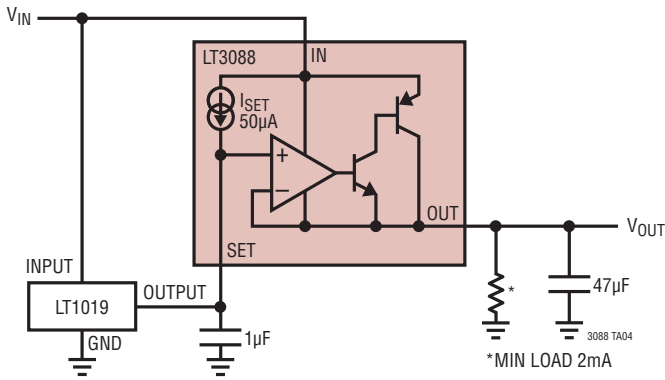

Adding Soft-Start

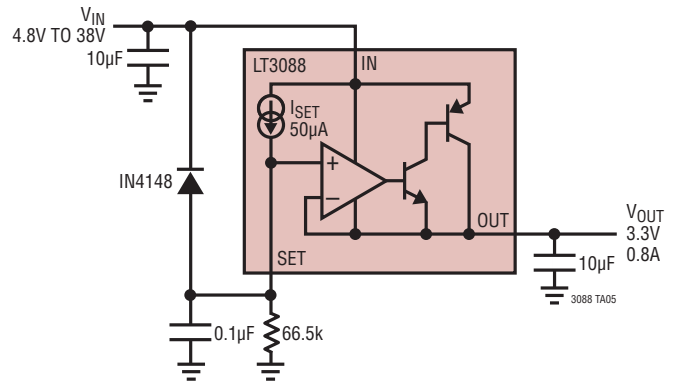

Using a Lower Value Set Resistor

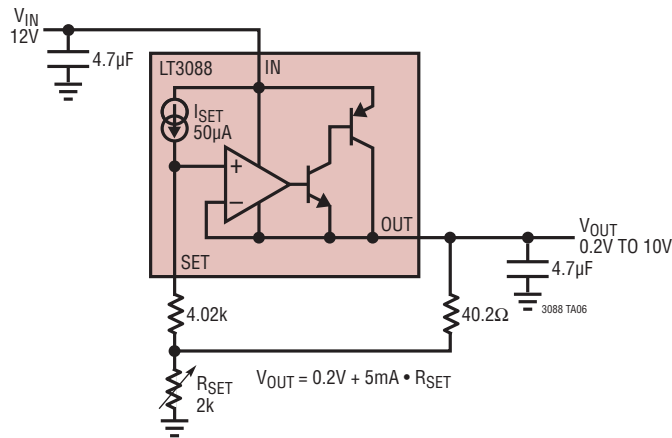

Using an External Reference Current

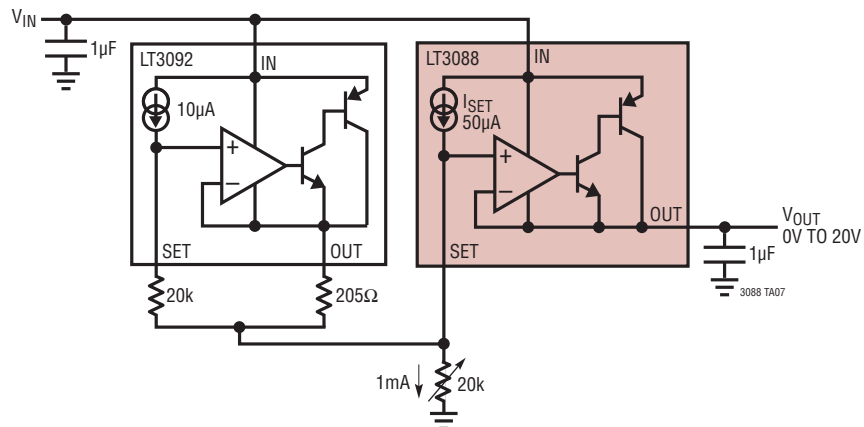

## PACKAGE DESCRIPTION

Please refer to <http://www.linear.com/product/LT3088#packaging> for the most recent package drawings.

**DD Package**  
**8-Lead Plastic DFN (3mm × 3mm)**  
 (Reference LTC DWG # 05-08-1698 Rev C)

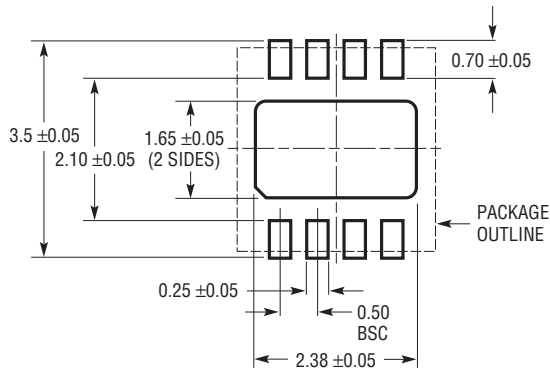

RECOMMENDED SOLDER PAD PITCH AND DIMENSIONS  
 APPLY SOLDER MASK TO AREAS THAT ARE NOT SOLDERED

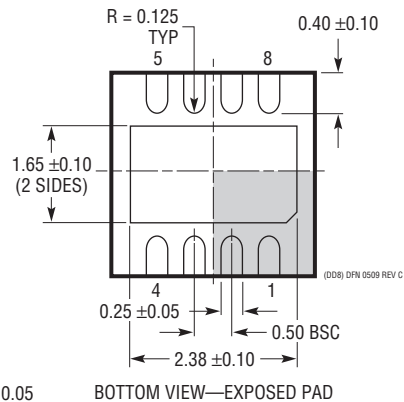
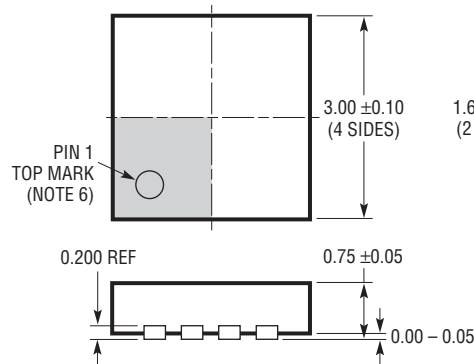

**NOTE:**

1. DRAWING TO BE MADE A JEDEC PACKAGE OUTLINE MO-229 VARIATION OF (WEED-1)
2. DRAWING NOT TO SCALE
3. ALL DIMENSIONS ARE IN MILLIMETERS
4. DIMENSIONS OF EXPOSED PAD ON BOTTOM OF PACKAGE DO NOT INCLUDE MOLD FLASH. MOLD FLASH, IF PRESENT, SHALL NOT EXCEED 0.15mm ON ANY SIDE
5. EXPOSED PAD SHALL BE SOLDER PLATED
6. SHADED AREA IS ONLY A REFERENCE FOR PIN 1 LOCATION ON TOP AND BOTTOM OF PACKAGE

# PACKAGE DESCRIPTION

Please refer to <http://www.linear.com/product/LT3088#packaging> for the most recent package drawings.

**ST Package**  
**3-Lead Plastic SOT-223**  
 (Reference LTC DWG # 05-08-1630)

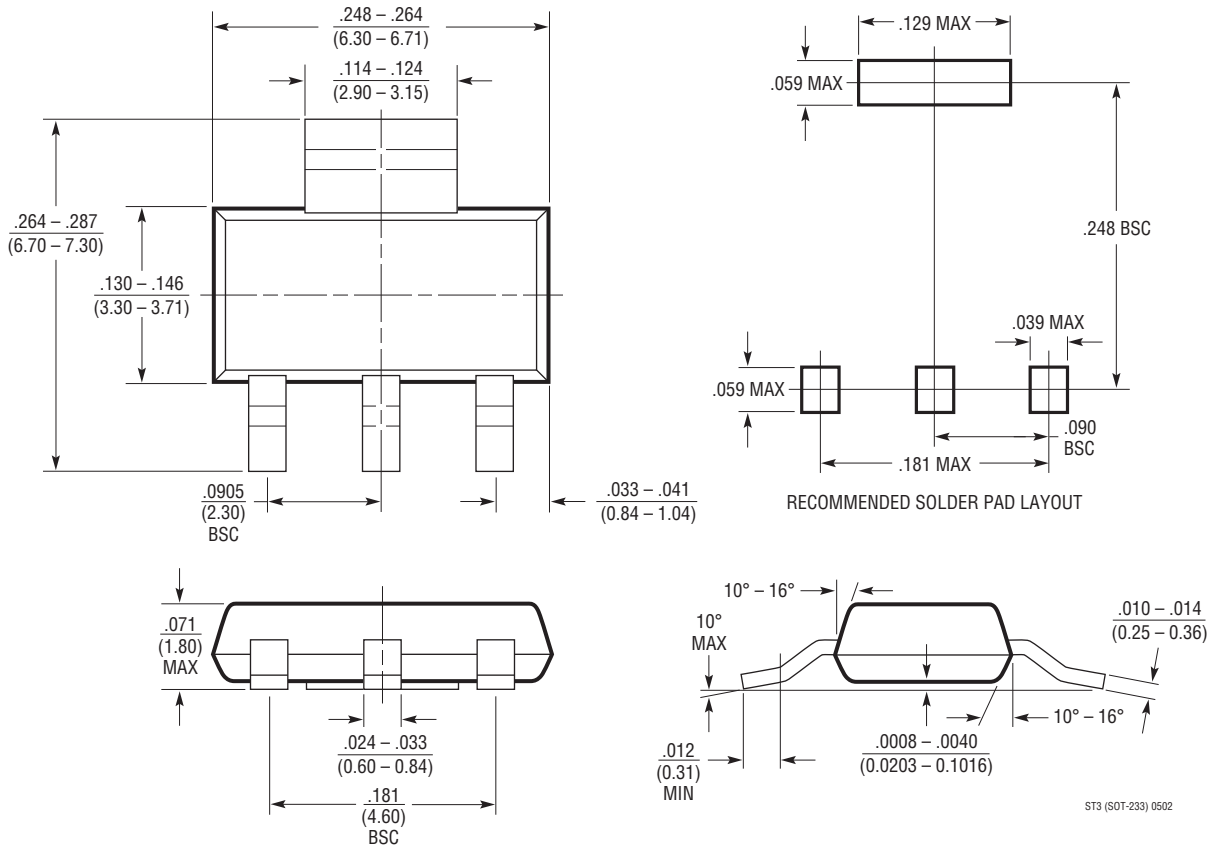

ST3 (SOT-223) 0502

**PACKAGE DESCRIPTION**

Please refer to <http://www.linear.com/product/LT3088#packaging> for the most recent package drawings.

**M Package**  
**3-Lead Plastic DD Pak**  
 (Reference LTC DWG # 05-08-1460 Rev F)

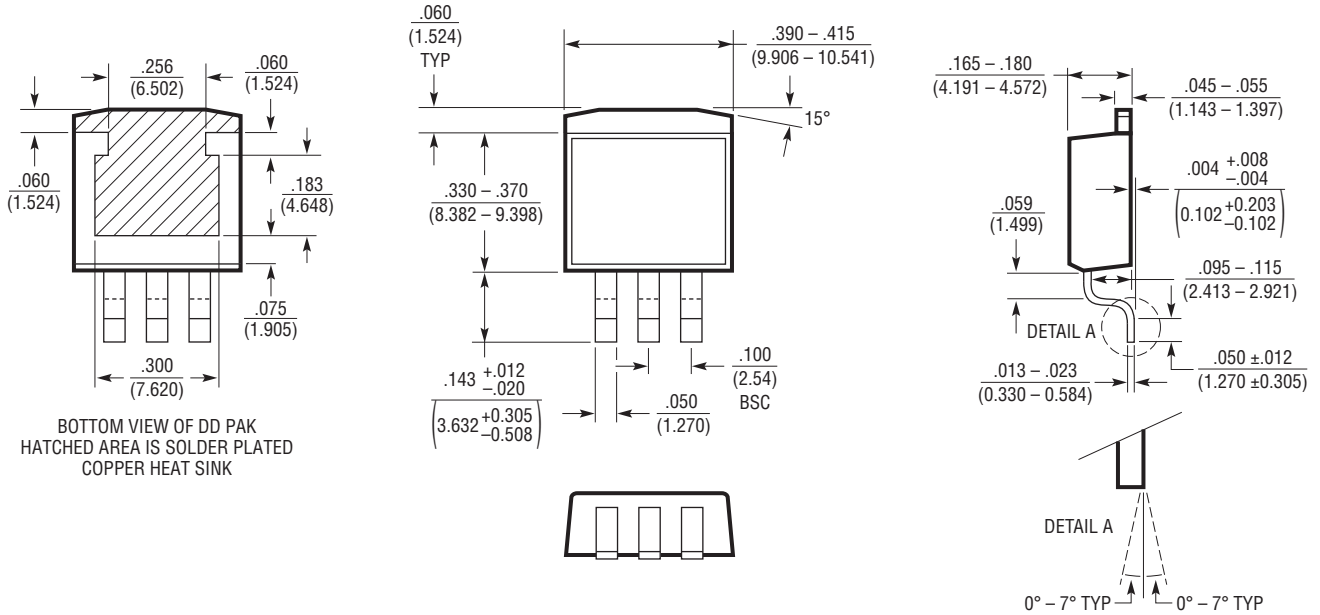

BOTTOM VIEW OF DD PAK  
 HATCHED AREA IS SOLDER PLATED  
 COPPER HEAT SINK

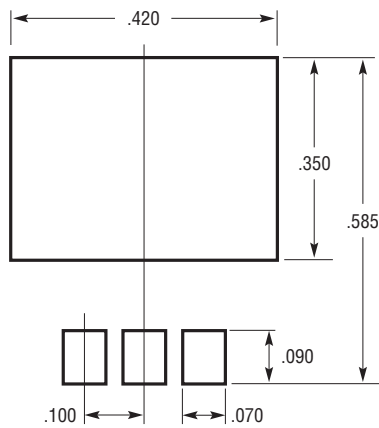

RECOMMENDED SOLDER PAD LAYOUT

- NOTE:  
 1. DIMENSIONS IN INCH/(MILLIMETER)  
 2. DRAWING NOT TO SCALE

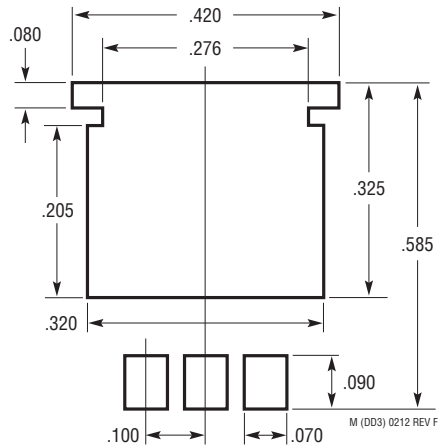

RECOMMENDED SOLDER PAD LAYOUT  
 FOR THICKER SOLDER PASTE APPLICATIONS

## REVISION HISTORY

REV	DATE	DESCRIPTION	PAGE NUMBER
A	9/15	Corrected Load Regulation conditions	3
		Corrected graph scales	5
		Corrected thermal numbers on parallel resistor use	19
B	10/15	Corrected pin numbers on SOT-223 package	2

## TYPICAL APPLICATION

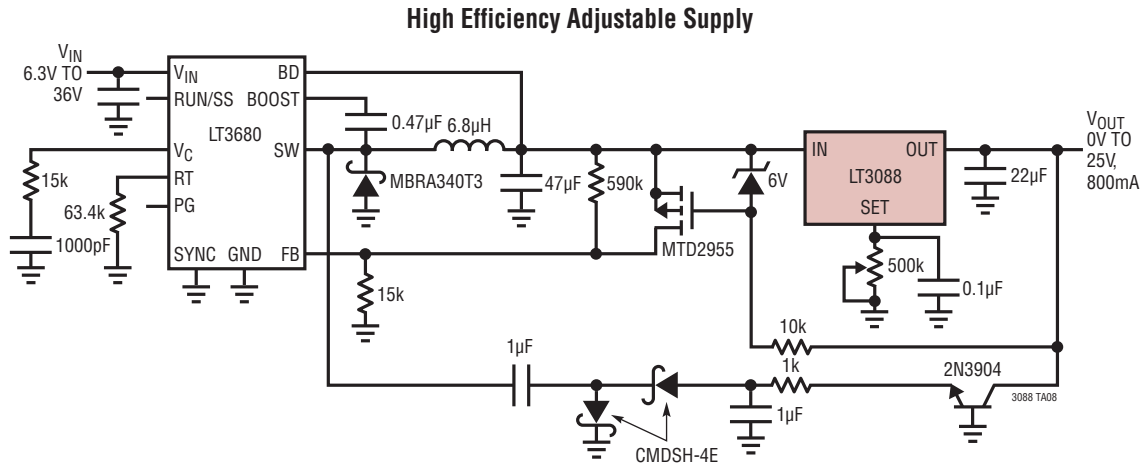



## RELATED PARTS

PART NUMBER	DESCRIPTION	COMMENTS
<a href="#">LT1185</a>	3A Negative Low Dropout Regulator	$V_{IN}$ : -4.5V to -35V, 0.8V Dropout Voltage, DD-Pak and TO-220 Packages
<a href="#">LT1764/ LT1764A</a>	3A, Fast Transient Response, Low Noise LDO	340mV Dropout Voltage, Low Noise: $40\mu V_{RMS}$ , $V_{IN}$ = 2.7V to 20V, TO-220, TSSOP and DD-Pak, LT1764A Version Stable Also with Ceramic Capacitors
<a href="#">LT1963/ LT1963A</a>	1.5A Low Noise, Fast Transient Response LDO	340mV Dropout Voltage, Low Noise: $40\mu V_{RMS}$ , $V_{IN}$ = 2.5V to 20V, LT1963A Version Stable with Ceramic Capacitors, TO-220, DD, TSSOP, SOT-223 and SO-8 Packages
<a href="#">LT1965</a>	1.1A, Low Noise, Low Dropout Linear Regulator	290mV Dropout Voltage, Low Noise: $40\mu V_{RMS}$ , $V_{IN}$ : 1.8V to 20V, $V_{OUT}$ : 1.2V to 19.5V, Stable with Ceramic Capacitors, TO-220, DD-Pak, MSOP and 3mm x 3mm DFN Packages
<a href="#">LT3022</a>	1A, Low Voltage, VLDO Linear Regulator	$V_{IN}$ : 0.9V to 10V, Dropout Voltage: 145mV Typical, Adjustable Output ( $V_{REF} = V_{OUT(MIN)} = 200mV$ ), Stable with Low ESR, Ceramic Output Capacitors, 16-Pin DFN (5mm x 3mm) and 16-Lead MSOP Packages
<a href="#">LT3070</a>	5A, Low Noise, Programmable $V_{OUT}$ , 85mV Dropout Linear Regulator with Digital Margining	Dropout Voltage: 85mV, Digitally Programmable $V_{OUT}$ : 0.8V to 1.8V, Digital Output Margining: $\pm 1\%$ , $\pm 3\%$ or $\pm 5\%$ , Low Output Noise: $25\mu V_{RMS}$ (10Hz to 100kHz), Paralleable: Use Two for a 10A Output, Stable with Low ESR Ceramic Output Capacitors (15µF Minimum), 28-Lead 4mm x 5mm QFN Package
<a href="#">LT3071</a>	5A, Low Noise, Programmable $V_{OUT}$ , 85mV Dropout Linear Regulator with Analog Margining	Dropout Voltage: 85mV, Digitally Programmable $V_{OUT}$ : 0.8V to 1.8V, Analog Margining: $\pm 10\%$ , Low Output Noise: $25\mu V_{RMS}$ (10Hz to 100kHz), Paralleable: Use Two for a 10A Output, $I_{MON}$ Output Current Monitor, Stable with Low ESR Ceramic Output Capacitors (15µF Minimum) 28-Lead 4mm x 5mm QFN Package
<a href="#">LT3080/ LT3080-1</a>	1.1A, Paralleable, Low Noise, Low Dropout Linear Regulator	300mV Dropout Voltage (2-Supply Operation), Low Noise: $40\mu V_{RMS}$ , $V_{IN}$ : 1.2V to 36V, $V_{OUT}$ : 0V to 35.7V, Current-Based Reference with 1-Resistor $V_{OUT}$ Set; Directly Paralleable (No Op Amp Required), Stable with Ceramic Capacitors, TO-220, DD-Pak, SOT-223, MS8E and 3mm x 3mm DFN-8 Packages; LT3080-1 Version Has Integrated Internal Ballast Resistor
<a href="#">LT3082</a>	200mA, Paralleable, Single Resistor, Low Dropout Linear Regulator	Outputs May Be Paralleled for Higher Output, Current or Heat Spreading, Wide Input Voltage Range: 1.2V to 40V Low Value Input/Output Capacitors Required: 2.2µF, Single Resistor Sets Output Voltage 8-Lead SOT-23, 3-Lead SOT-223 and 8-Lead 3mm x 3mm DFN Packages
<a href="#">LT3085</a>	500mA, Paralleable, Low Noise, Low Dropout Linear Regulator	275mV Dropout Voltage (2-Supply Operation), Low Noise: $40\mu V_{RMS}$ , $V_{IN}$ : 1.2V to 36V, $V_{OUT}$ : 0V to 35.7V, Current-Based Reference with 1-Resistor $V_{OUT}$ Set; Directly Paralleable (No Op Amp Required), Stable with Ceramic Capacitors, MS8E and 2mm x 3mm DFN-6 Packages
<a href="#">LT3092</a>	200mA 2-Terminal Programmable Current Source	Programmable 2-Terminal Current Source, Maximum Output Current = 200mA, Wide Input Voltage Range: 1.2V to 40V, Resistor Ratio Sets Output Current, Initial Set Pin Current Accuracy = 1%, Current Limit and Thermal Shutdown Protection, Reverse-Voltage Protection, Reverse-Current Protection, 8-Lead SOT-23, 3-Lead SOT-223 and 8-Lead 3mm x 3mm DFN Packages.
<a href="#">LT3083</a>	Adjustable 3A Single Resistor Low Dropout Regulator	Low Noise: $40\mu V_{RMS}$ , 50µA Set Pin Current, Output Adjustable to 0V, Wide Input Voltage Range: 1.2V to 23V (DD-Pak and TO-220), Low Dropout Operation: 310mV (2 Supplies)

3088fb

## Looking for pricing, stock, or lifecycle information?

Click below to explore more details on WIN SOURCE:

-  [View DC2279A on WIN SOURCE](#)
-  [Analog Devices Inc. Information](#)

## Optimize Your Supply Chain with WIN SOURCE Solutions

-  Global Sourcing Solution
-  Obsolete Management
-  Cost Control Management
-  Shortage Management
-  Alternative Solution
-  Excess Inventory Management