



THE DATASHEET OF
P522304



Part No. P522304 / 9000154

Broadband FR4 Embedded Cellular Antenna

850 / 900 / 1800 / 1900 / 2100 MHz

Supports: Broadband LTE (OCTA-BAND), LTE CAT-M, NB-IoT, SigFox, LoRa, Cellular LPWA, RPMA, Firstnet



*Mirrored version offered as 9000154

Broadband FR4 Embedded Cellular Antenna

Low Band 824 – 960 MHz
 High Band 1710 - 2170 MHz

KEY BENEFITS

Reduced Costs and Time-to-Market

Standard antenna eliminates design fees and cycle time associated with a custom solution; getting products to market faster.

Greater Flexibility with Unique Form Factors

KYOCERA AVX's technology helps you deliver more advanced ergonomic designs without adverse impact on product performance. **Reliability**
 Comply with latest RoHS requirements

APPLICATIONS

- Medical applications
- Home automation
- Smart metering
- M2M, Industrial devices
- IoT
- Firstnet
- Automotive
- Healthcare
- Point of Sale
- Tracking
- Cellular
- 3G Systems

KYOCERA AVX's Broadband Embedded Cellular antenna utilizes Isolated Magnetic Dipole™ (IMD) technology which address the challenges facing today's product designers. IMD's high performance and isolation characteristics offer better connectivity and minimal interference. Mirrored version variant offered as 9000154.

Stays in Tune

IMD antenna technology provides superior RF field containment, resulting in less interaction with surrounding components. KYOCERA AVX IMD antennas resist detuning; providing a robust radio link regardless of the usage position

KYOCERA AVX antennas use patented IMD technology in many antenna configurations to provide high performance. IMD antennas requires a smaller design keep-out area, carry lower program development risk which yields a quicker time-to-market, without sacrificing RF performance.

Electrical Specifications

Typical Characteristics, on 50 x 110 mm PCB

Frequency	824 - 960 MHz	1710 - 2170 MHz
Efficiency	62%	55%
VSWR	2.5:1 max	2.7:1 max
Peak Gain	0 dBi	0.7 dBi
Polarization	Linear	
Power Handling	2 Watts CW	
Radiation Pattern	Omni-directional	
Feed Point Impedance	50 ohms unbalanced	

Mechanical Specifications & Ordering Part Number

Ordering Part #	P522304
Dimensions (mm)	35.0 x 9.0 x 3.2
Weight (grams)	2.1
Mounting	SMT (P&P)
Packaging	1,120 pcs/reel; 5,600 pcs/box
Demo Board	P522304-02

Cellular FR4 KYOCERA AVX's Embedded Antenna Specifications.
KYOCERA AVX produces a wide variety of standard and custom antennas to meet user needs.

Antenna Dimensions

Typical antenna dimensions (mm)

Part Number	A (mm)	B (mm)	C (mm)
P522304	35.0 ± 0.3	9.0 ± 0.2	3.2 ± 0.3

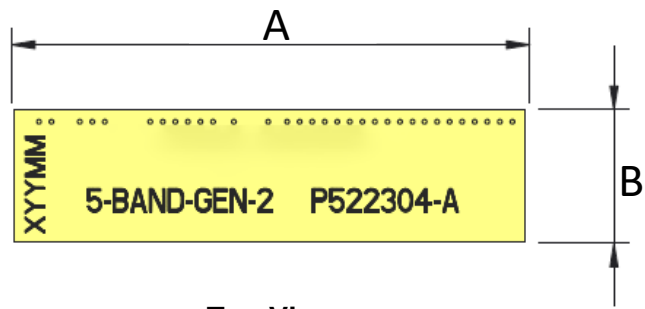

Top View

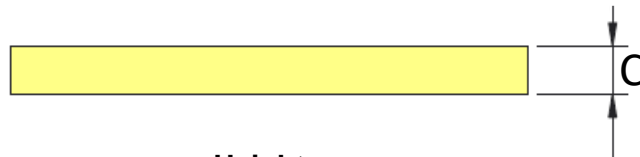

Height

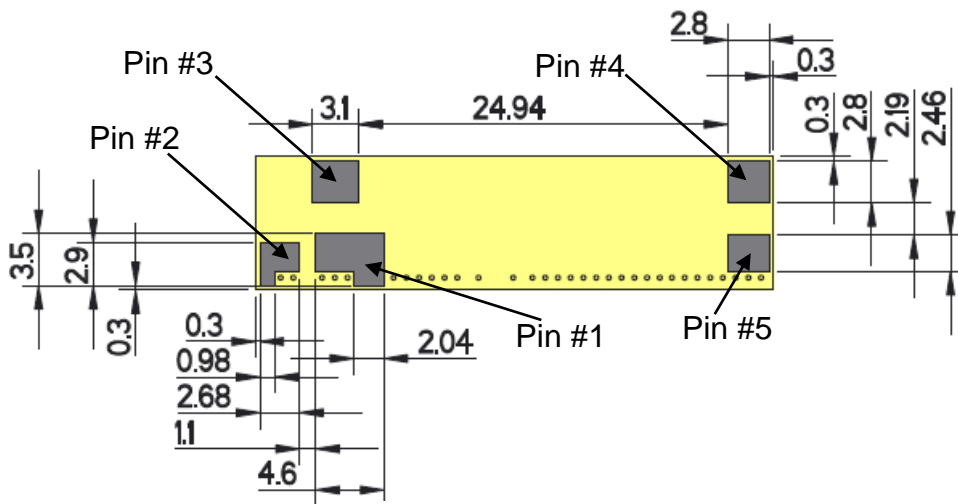

Bottom View

Pin Descriptions

Pin#	Description
1	Feed
2	Ground
3	Dummy Pad
4	Dummy Pad
5	Low Band Tuning

Cellular FR4 KYOCERA AVX's Embedded Antenna Specifications.
KYOCERA AVX produces a wide variety of standard and custom antennas to meet user needs.

VSWR and Efficiency Plots (Off-Ground)

Typical Performance on 50 x 110 mm PCB

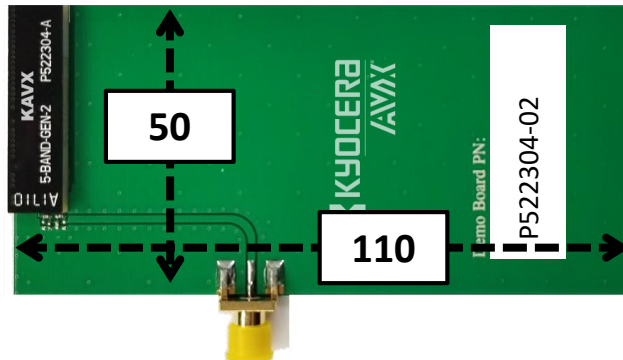

Low Band VSWR

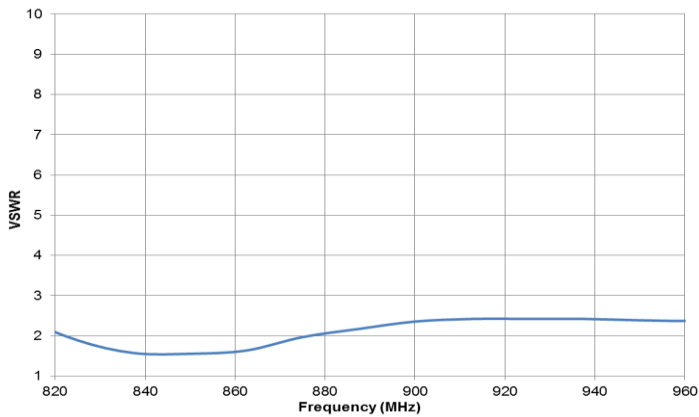

High Band VSWR

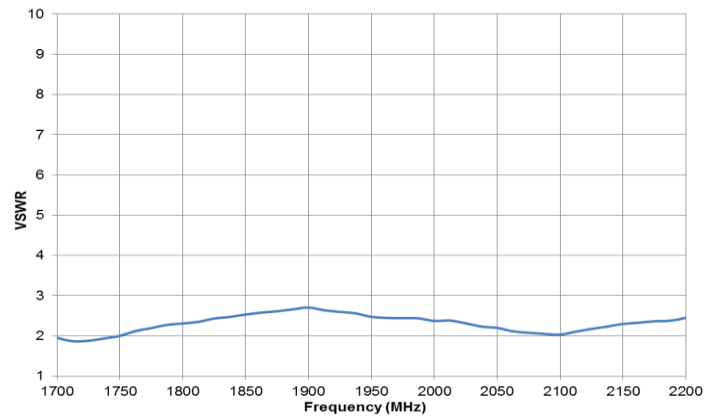

Low Band Efficiency

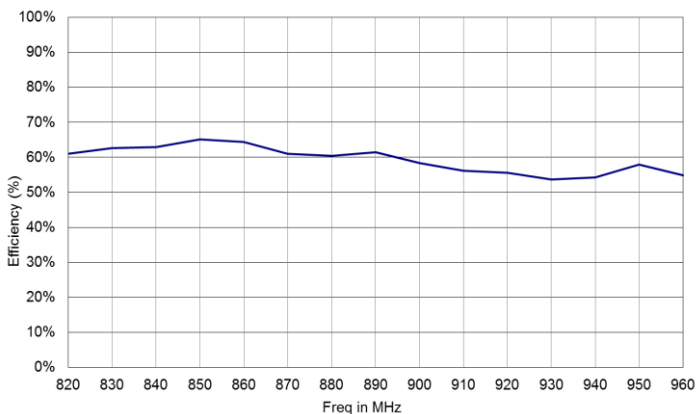

High Band Efficiency

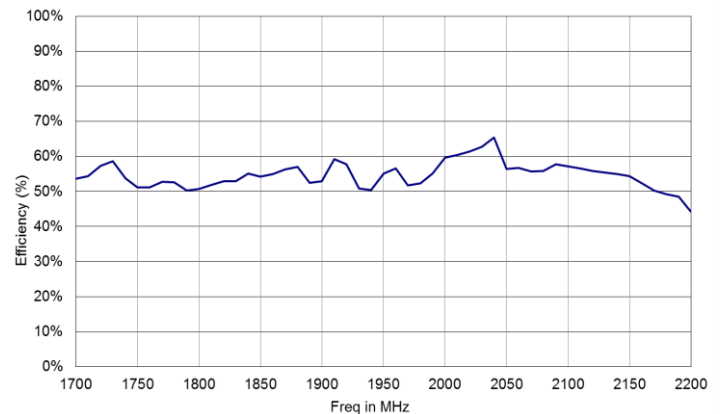

Cellular FR4 KYOCERA AVX's Embedded Antenna Specifications.
 KYOCERA AVX produces a wide variety of standard and custom antennas to meet user needs.

Antenna Radiation Patterns

Typical Performance on 50 x 110 mm PCB
 Measured @ 910, 1870 MHz



Measured at 910 MHz

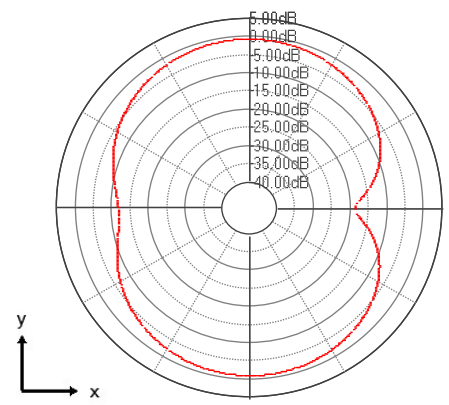
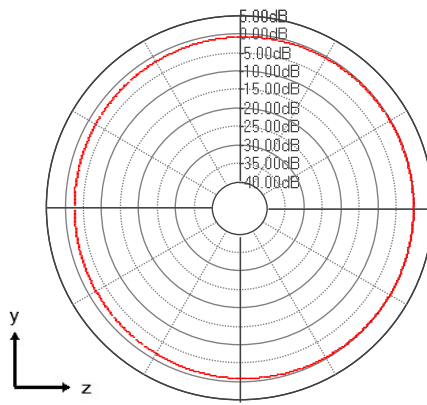
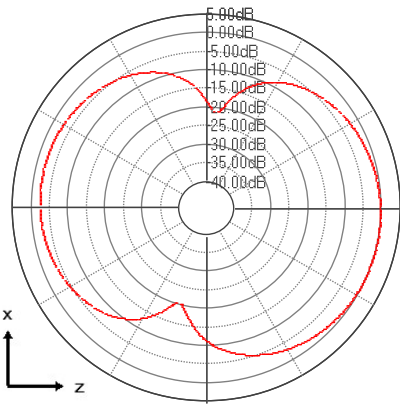

Measured at 1870 MHz

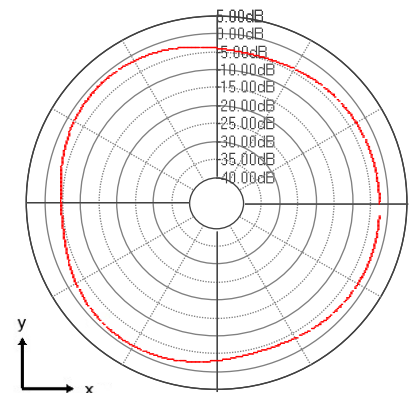
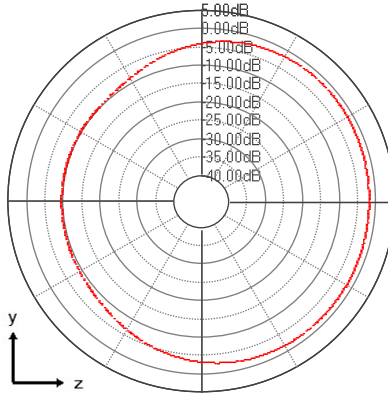
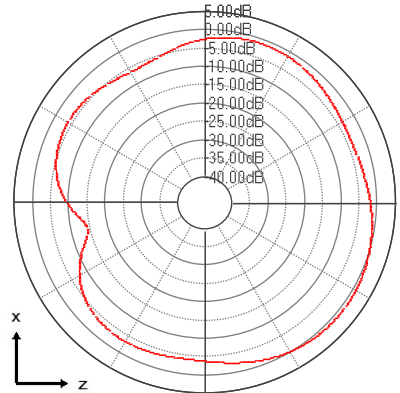

Cellular FR4 KYOCERA AVX's Embedded Antenna Specifications.
 KYOCERA AVX produces a wide variety of standard and custom antennas to meet user needs.

Antenna Layout (On-Ground)

Typical layout dimensions (mm)

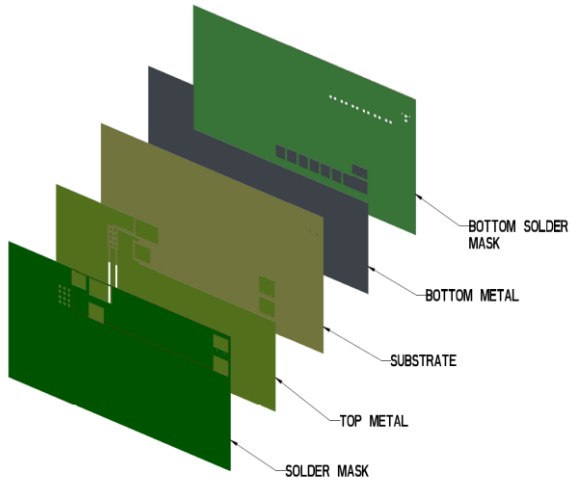

* VIAS: Diam. 0.2mm, (no vias on transmission lines).
 Via holes must be covered by solder mask

Pin Descriptions

Pin#	Description
1	Feed
2	Ground
3	Dummy Pad
4	Dummy Pad
5	Low Band Tuning

Matching & Tuning Component Values

Component	Value	Tolerance
P1	3.6nH	±0.05nH
S1	1.2pF	±0.05pF
S2	15nH	±0.3nH
P2	1.8pF	±0.05pF
R1 – R7	DNI	N/A

Default Pi Matching Network values and (R1- R7) tuning instructions can be found under Antenna Matching Structure..

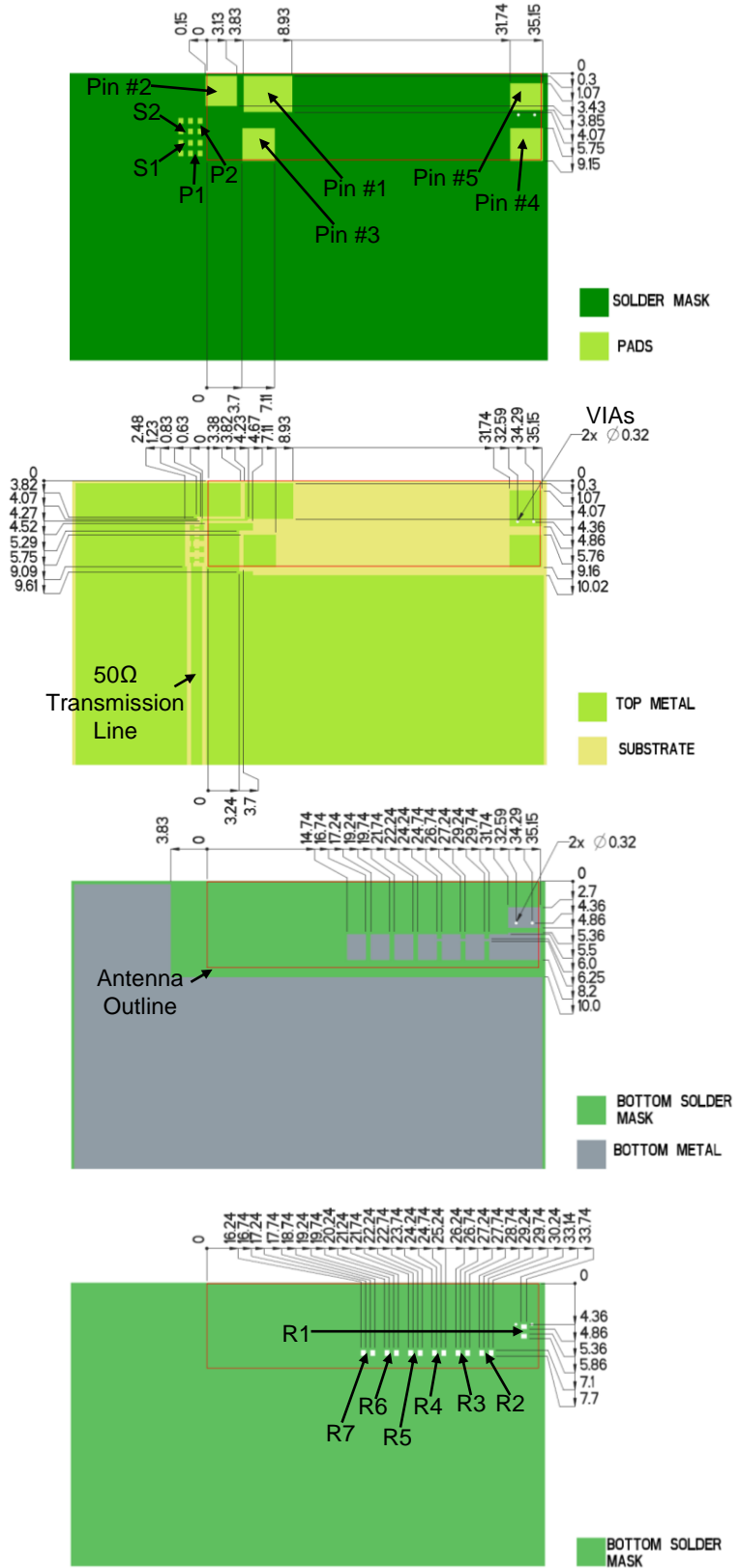

Cellular FR4 KYOCERA AVX's Embedded Antenna Specifications.
KYOCERA AVX produces a wide variety of standard and custom antennas to meet user needs.

Antenna Matching Structure

Typical matching values on 50 x 110 mm PCB

Demo Board Front View

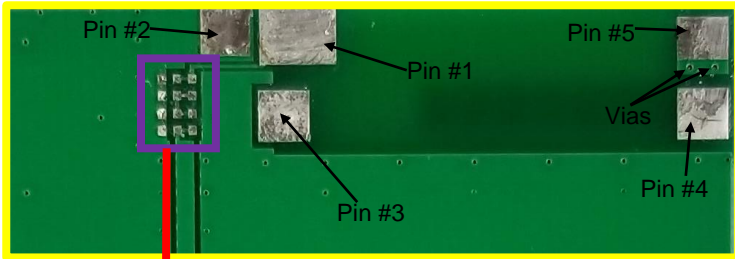

Demo Board Back View

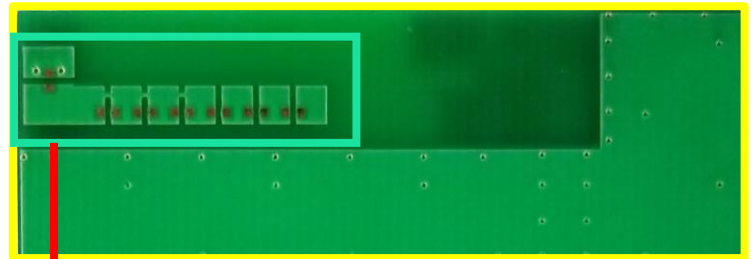

Antenna Matching

Low Band Tuning

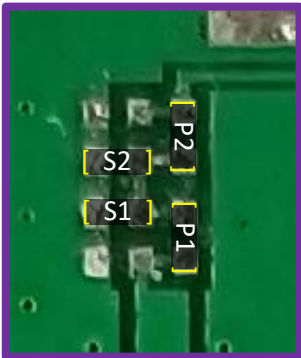

(Antenna Matching): pads are directly inline with the antenna feed trace.

Tune Low Band Higher
(Cut Bridge Trace)

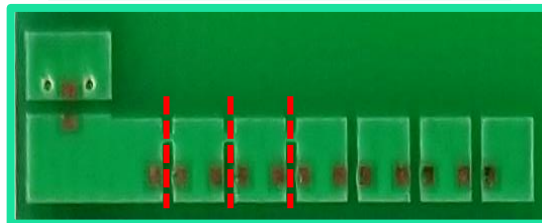

*Cut Trace between pads shifts resonant frequency higher

Tune Low Band Lower
(Add 0Ω)

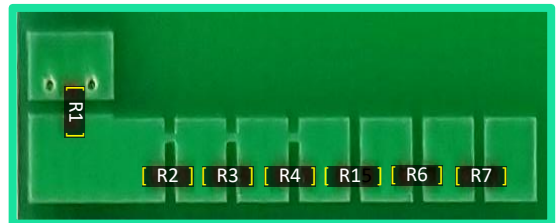

*Bridging gaps with 0 ohm resistors shifts resonant frequency lower

Pin Descriptions

Pin#	Description
1	Feed
2	Ground
3	Dummy Pad
4	Dummy Pad
5	Low Band Tuning

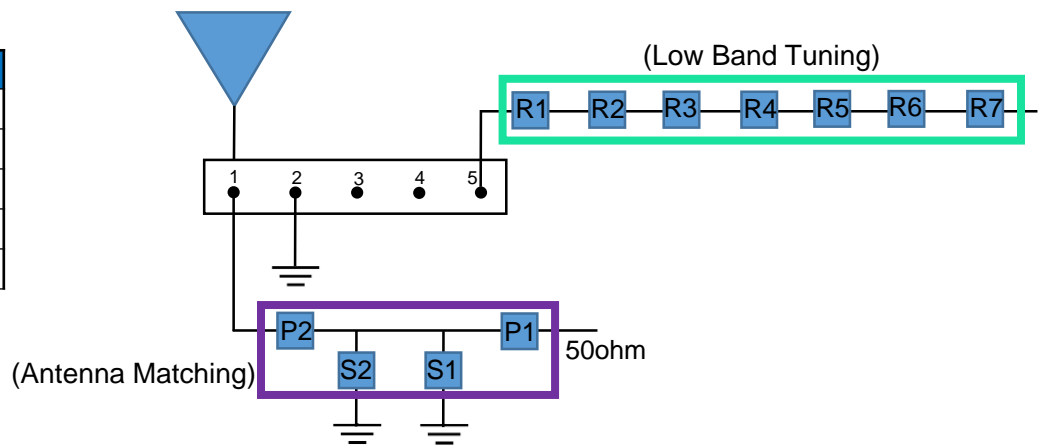

	P1	S1	S2	P2	(R1 - R7)
Default Matching	3.6nH	1.2pF	15nH	1.8pF	DNI
Tolerance	±0.05nH	± 0.05pF	±0.3nH	± 0.05pF	N/A

Cellular FR4 KYOCERA AVX's Embedded Antenna Specifications.
 KYOCERA AVX produces a wide variety of standard and custom antennas to meet user needs.

Antenna Demo Board

Demo Board Front View/Back View

Part Number	A (mm)	B (mm)	C (mm)
P522304-02	110	50.0	15.0



Front View

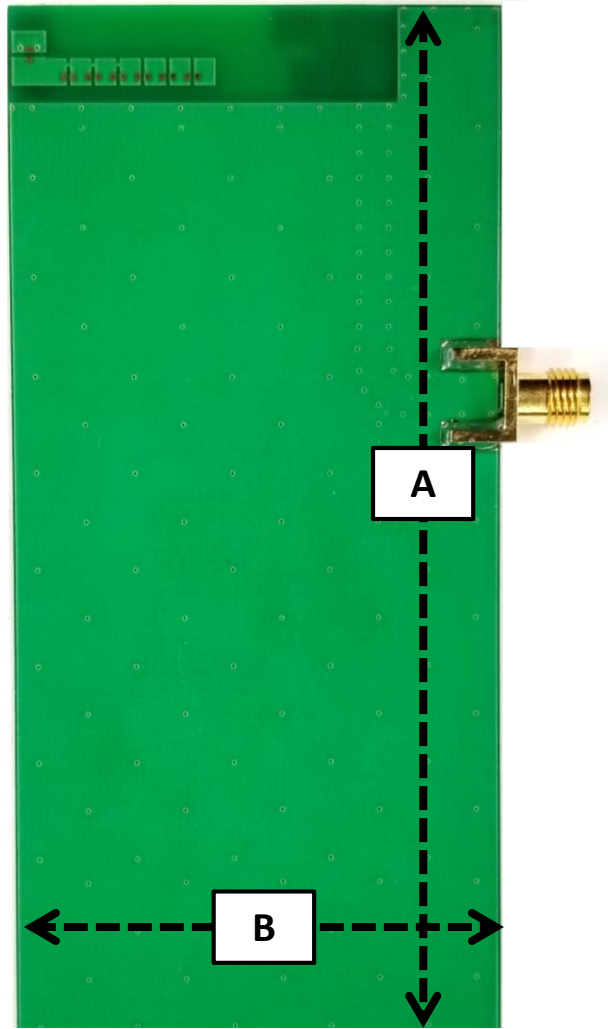

Back View

Cellular FR4 KYOCERA AVX's Embedded Antenna Specifications.
 KYOCERA AVX produces a wide variety of standard and custom antennas to meet user needs.

Recommended Reflow Soldering Profile

The recommended method for soldering the antenna to the board is forced convection reflow soldering. The following suggestions provide information on how to optimize the reflow process for the FR4 antenna:

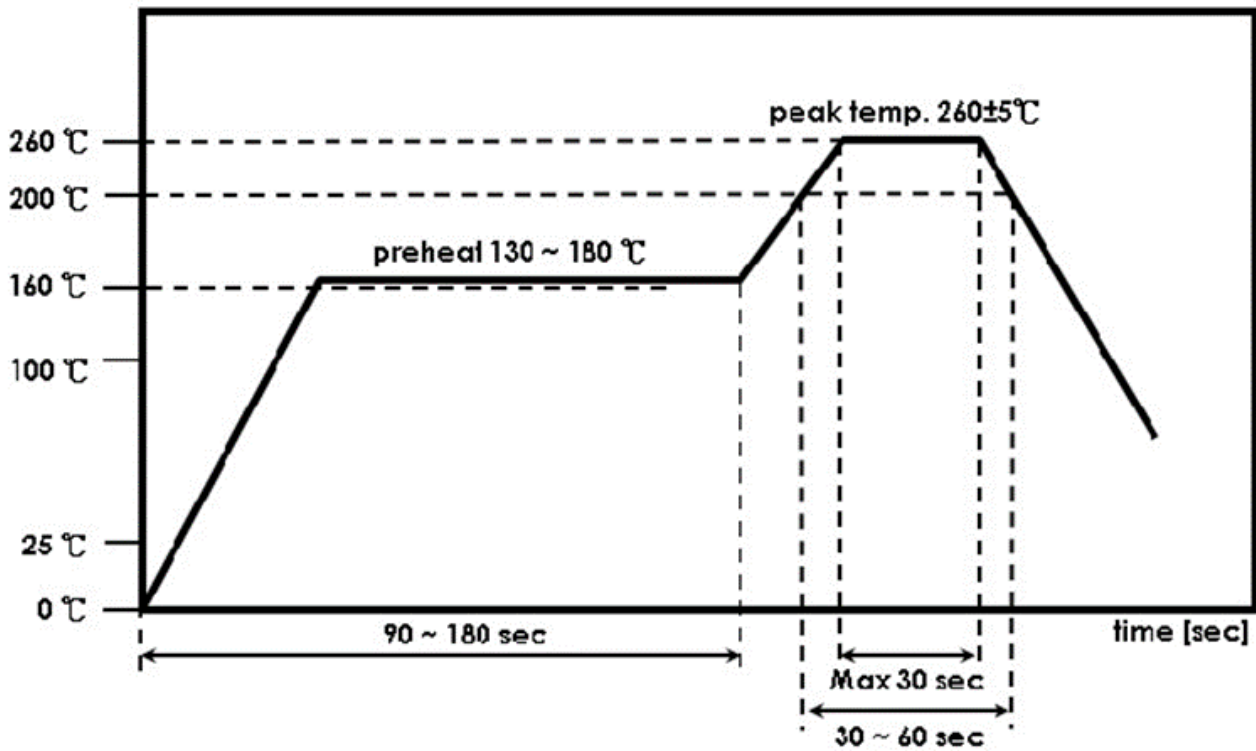

*Adjust the reflow duration to create good solder joints without raising the antenna temperature beyond the allowed maximum of 260° C.

Looking for pricing, stock, or lifecycle information?

Click below to explore more details on WIN SOURCE:

 [View P522304 on WIN SOURCE](#)

 [Ethertronics/AVX Information](#)

Optimize Your Supply Chain with WIN SOURCE Solutions

-  Global Sourcing Solution
-  Obsolete Management
-  Cost Control Management
-  Shortage Management
-  Alternative Solution
-  Excess Inventory Management