



**THE DATASHEET OF
IPS15C-SO-G-LF-T**



INTRODUCTION

DESCRIPTION

The IN-PLUG® IPS15 is an enhanced off-line switcher version of the IPS10. It includes additional features such as soft start and over-voltage limiting. As the IPS10, the IPS15 Integrated Circuit was especially designed for low-cost, high efficiency, low-power fly-back off-line switching power supplies up to approximately 50 to 70W. It contains a shunt-regulator, a precision oscillator, a PWM with its associated comparator and loop compensation components as well as all the necessary biasing and protection circuitry (thermal shutdown, under-voltage, over-voltage and over-current).

It is optimized to operate with an optocoupler to provide the feedback from the secondary but can also be used with a bias winding which could sometimes be more economical.

Typical applications include domestic and international power supplies featuring AC input ranging from 90 to 264V and DC from 100 to 350V.

In addition to being a low-cost IC, the IPS15 allows further cost reduction for the complete power supply thanks to:

- fewer and cheaper associated components
- a simpler, cheaper and more forgiving fly-back transformer.

For very low power applications the IPS15 can be powered from the rectified AC through a simple resistor.

For higher power applications, the IPS15 is powered through a novel patented network which replaces the usual snubber network. AAI will grant one non-exclusive royalty free licence to use this arrangement for each IPS15 purchased by Customers, either directly from the company or through approved sources.

The IN-PLUG® IPS15 can drive a large variety of power MOSFETs hence providing the maximum flexibility at the lowest possible cost.

FEATURES

- Lowest cost solution for low-power off-line flyback applications.
- High performance yet forgiving.
- Simple, less critical, lower cost transformer.
- Wide range PWM for stable operation at any load and line voltage.
- Suitable for constant-power applications.
- Operates with optocoupler or bias winding for constant voltage applications: zeners, adjustable shunt regulator like TL431 or dedicated feedback controllers like AAI precision IPS22 & IPS25.
- EMI reduction in critical applications thanks to:
 - Adjustable operating frequency.
 - Separate MOSFET N & P drives
- Power shut-down for stand-by modes.
- Cycle to cycle over-current protection
- Under-voltage and over-voltage protection.
- External component savings: MOV, X-cap, Y-cap (ESD/lightning permitting)

APPLICATIONS

- Standby power supplies for TV, VCR and IR remotely-controlled appliances.
- Cordless and feature phones.
- Cellular phone chargers.
- Power tools fast chargers with trickle and on/off.
- Laptops and personal digital assistants.
- Utility meters.
- Replacements for bulky plug-in transformers.

PIN CONFIGURATION: DIP-8 / SOIC-8

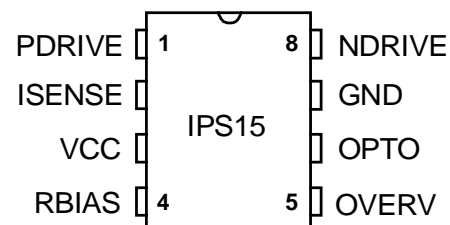

FUNCTIONAL BLOCK DIAGRAM

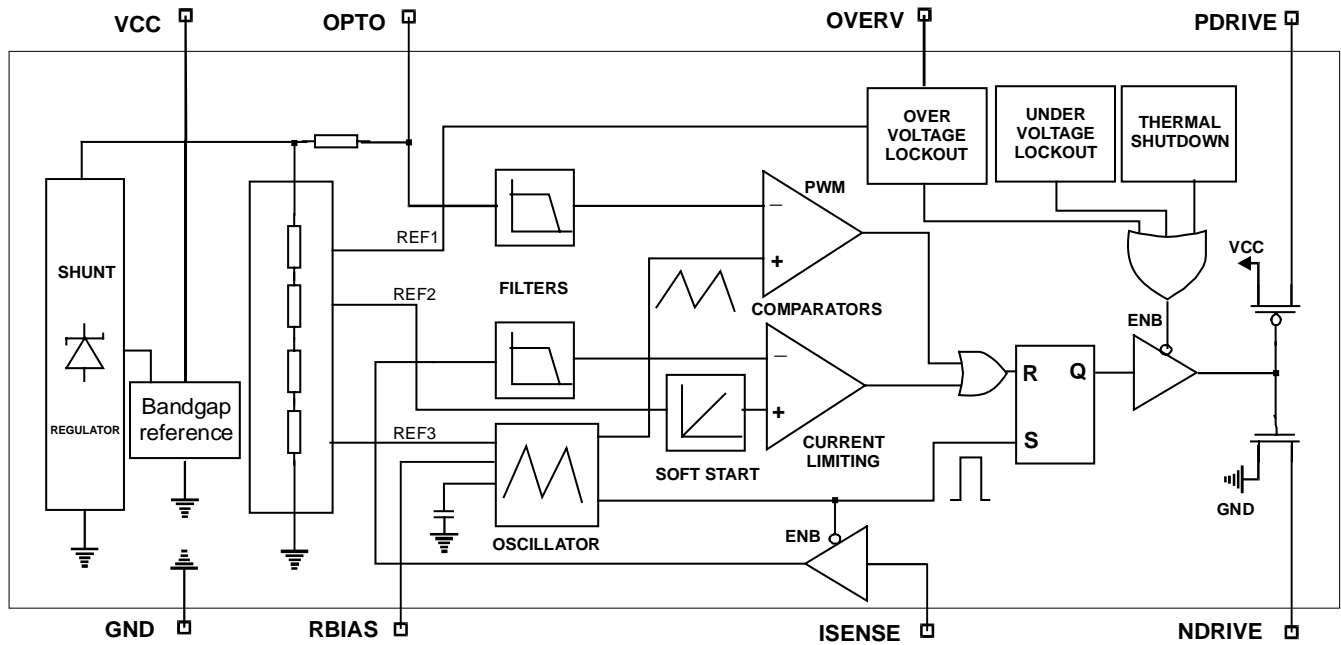

TYPICAL APPLICATION SCHEMATIC: AC IN 110V, 5W OUTPUT, zener regulation (EMC components not shown).

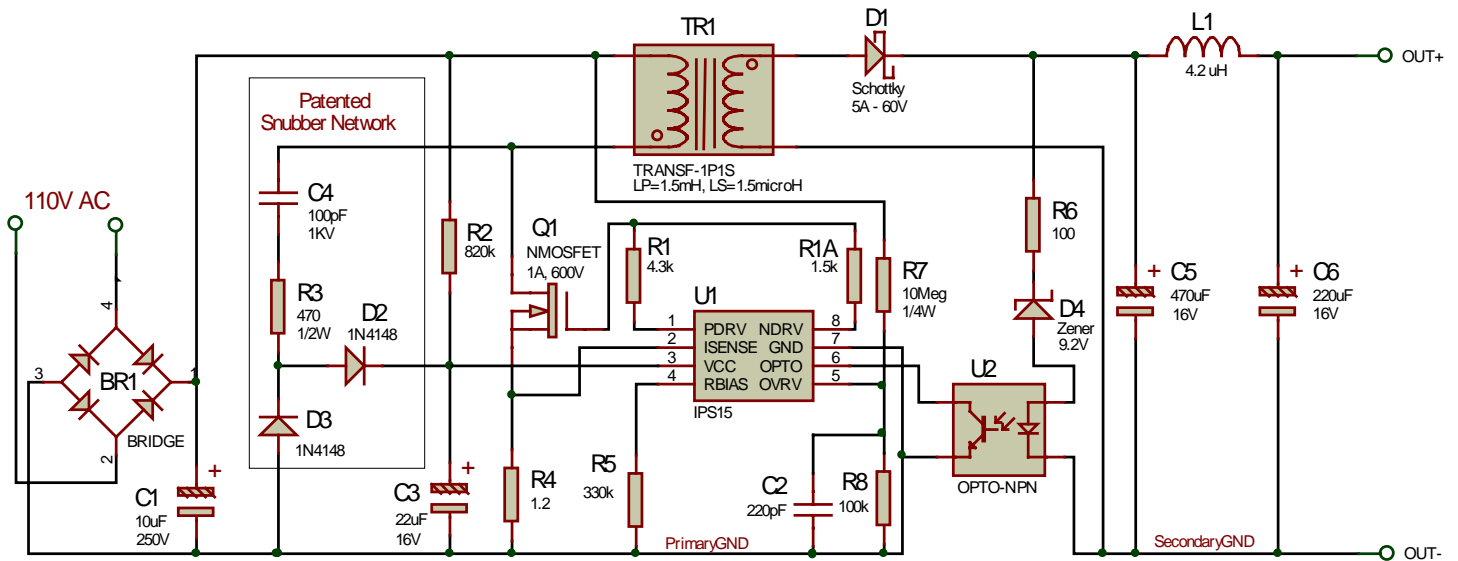

Figure 1

PIN DESCRIPTION

Number	Name	Description
1	PDRIVE	Internal P drive terminal to be connected to the gate of the outside power MOSFET. (The rising edge can be adjusted with an external resistor)
2	I _{SENSE}	MOSFET current sensing. Any voltage over 700 mv @ 25°C on this pin will stop gate pulses.
3	V _{CC}	IC positive supply. The chip behaves like a 9.5 volts zener diode.
4	R _{BIAS}	External R _{BIAS} connection to set the operating frequency.
5	OVERV	Over-voltage lock-out pin. @ 25°C a voltage over 4V on this pin will pull the MOSFET gate to GND.
6	OPTO	Feedback input
7	GND	Ground
8	NDRIVE	Internal N drive terminal to be connected to the gate of the outside power MOSFET. (The falling edge can be adjusted with an external resistor)

IN-PLUG® IPS15 SERIES FUNCTIONAL DESCRIPTION

The **IPS15** is a PWM controller for fly-back switching power supply applications. It has been optimized to reduce the external component count. The principal features are:

- Low start Current.
- Shunt regulator to allow the maximum flexibility to power the chip.
- Protections against overheating, under-voltage and over-voltage.
- Precise oscillator with externally adjustable frequency.
- On-chip filters for the loop compensation and the over-current sensing.
- Soft start and over-voltage shut-down to protect the MOSFET.
- Separate MOSFET P and N drivers to adjust rising and falling edge independently.

The shunt regulator operates like a zener diode, keeping the chip supply voltage around 9.5 volts. At start-up the chip stays in stand-by mode until the voltage of V_{CC} reaches about 9.5 volts. During this phase, the consumption is of the order of 120 μ A. When the 9.5 volts are reached, the driver starts providing gate pulses. The chip will go back to the stand-by mode if the supply voltage decreases down to ~8 volts. The overall chip consumption in normal operation is about 600 μ A, not counting the current required to drive the MOSFET gate.

For domestic application, the chip can be supplied from the rectified line voltage through a resistor. In such case, the resistor has to be sized to drive enough current to the chip.

For international applications, the IC gets the start current from a resistor connected to the rectified line voltage (~150 μ A) then, after the first gate pulse, the patented modified snubber network (*) provides the additional current to keep the chip running.

The opto pin is pulled to V_{CC} through an internal resistor, allowing a maximal duty cycle of 60 %. During start-up, the duty cycle is controlled by the internal soft start unit which smoothly increases the MOSFET current up to its maximum, corresponding to 700mV developed across the sense resistor.

When the expected output voltage is reached, the optocoupler's led is driven, and the opto pin voltage decreases, reducing the duty cycle to a controlled value. The current limiting protection operates by turning-off the MOSFET when the I_{SENSE} pin voltage exceeds ~700 mv. This ensures a cycle to cycle protection of the MOSFET and provides a mean of operating the power supply in constant-power mode.

The voltage limiting protection operates by turning-off the MOSFET when the OVERV pin voltage exceeds 4V.

(*) *US Patent # 6,233,165 - Royalty free licence for IN-PLUG® Customers.*

AC 110V- IPS15 operations at medium load (5W)*

IPS15 operations at heavy load (15W)*

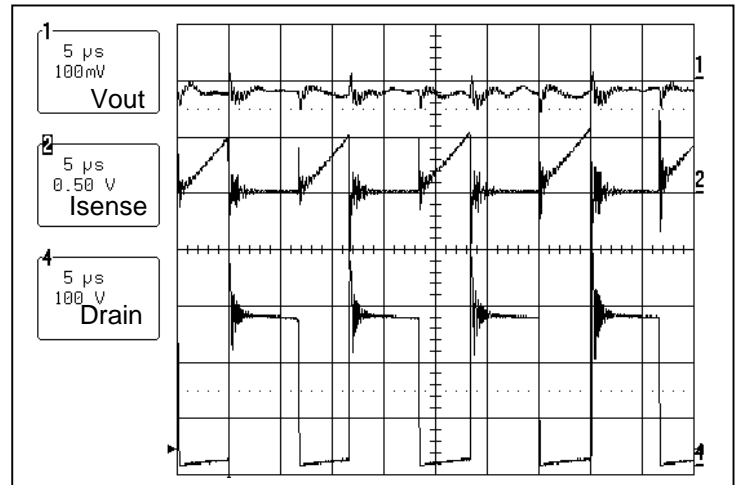
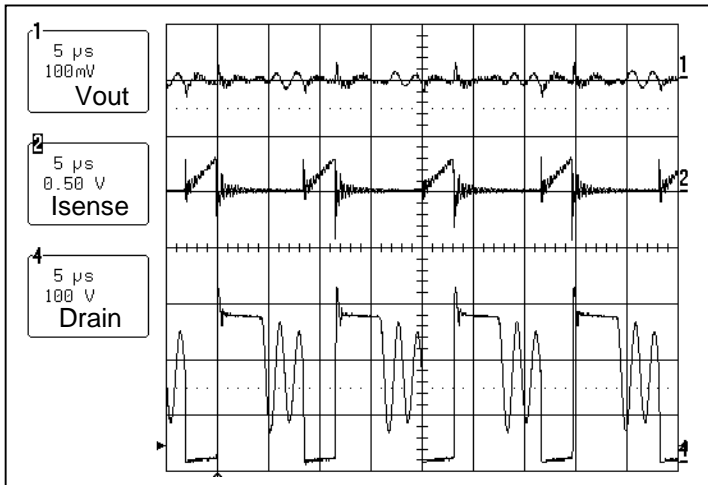

AC 250V - IPS15 operations at medium load (5W)*

IPS15 operations at heavy load (15W)*

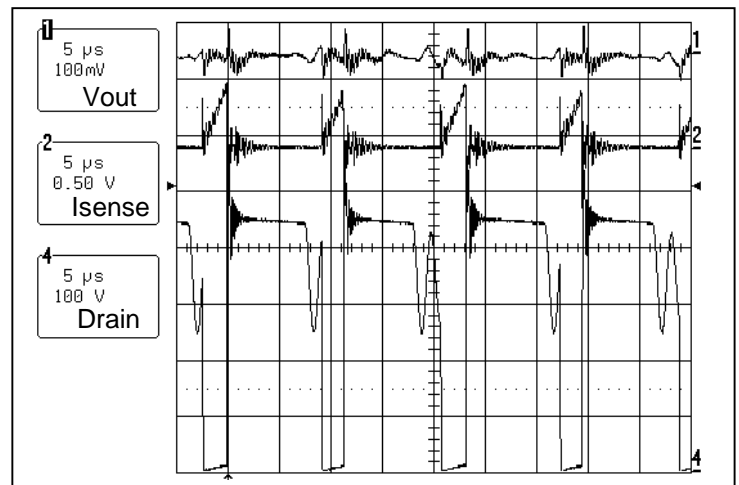
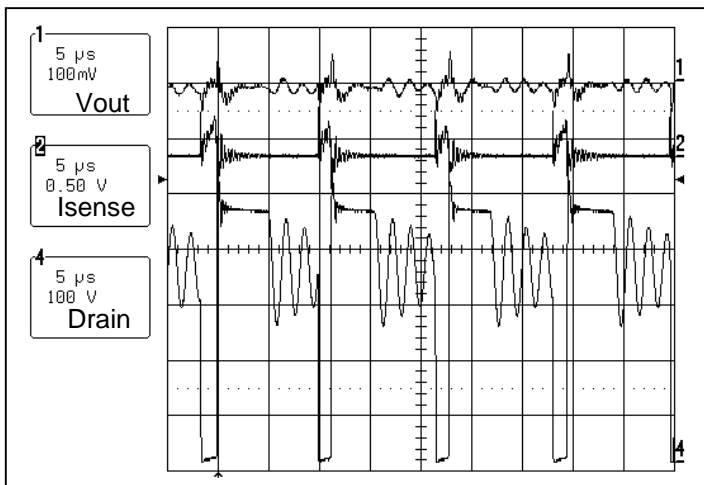

* Together with a 1A, 600V MOSFET.

OUTPUT POWER CAPABILITY			
Part Number	Package	230V AC or 115V AC w/ Doubler	85 – 285V AC
IPS15	DIP-8 / SOIC-8	Up to 70W (1)	Up to 30W (1)

Note (1): Governed by size and package of external MOSFET

ELECTRICAL CHARACTERISTICS

ABSOLUTE MAXIMUM RATING		
Characteristics	Value	UNITS
Shunt regulator max I_{CC} (pin 3) - see fig 4-	50	mA
All analog inputs (pin 2, 4, 5, 6)	Min= -0.3, Max= +6.3V	V
Peak drive output current (pin1)	Source=100, Sink=170	mA
Junction to case thermal resistance $R_{\theta J-C}$	PDIL = 42, SOIC = 45	°C / W
Junction to PCB thermal resistance $R_{\theta J-A}$	PDIL = 125, SOIC =155	
Power dissipation for $T_A \leq 70^\circ\text{C}$	PDIL = 640, SOIC = 500	mW
Operating junction temperature	- 40 to 150	°C
Storage temperature range	- 55 to 150	
Lead temperature (3 mm from case for 5 sec.)	260	

PARAMETER	TEST CONDITIONS	PARAMETERS			UNITS
		MIN.	TYP.	MAX.	
Supply, bias & circuit protection					
Shunt regulator voltage	$I_{CC} = 1$ to 30 mA	9.2	9.7	10.5	V
Shunt regulator dynamic resistance (see Fig. 4)	1 to 30 mA	2	3	5	Ω
Shunt regulator max peak repetitive current		-	35	-	mA
Min I_{CC} to start oscillator		-	-	140	μA
Under voltage lock-out		$V_{CC} - 2.2$	$V_{CC} - 1.5$	$V_{CC} - 1.4$	V
Min I_{CC} to ensure continuous operation	1A, 600V, 5 nC MOSFET	1.1 @ 20KHz	3.2 @ 80KHz	4.9 @ 150KHz	mA
Current limiting sensing voltage		655	700	745	mV
Temperature coefficient of current limiting		-	-	50	$\mu\text{V}/^\circ\text{C}$
Overvoltage sensing voltage		3.85	4	4.15	V
Soft/start duration	0 to 700mV	-	20	-	clock cycles
Leading edge blanking		200	-	450	ns
Thermal shutdown trip temperature		-	150	-	°C
Oscillator & PWM					
Range of operating frequencies		30	80	150	KHz
RBIAS values for above frequencies (see figure 2)		550	170	80	K Ω
Oscillator stability with supply & temperature (see figure 3 for average)	$I_{CC} = 5$ mA Temp = 0 to 70°C	-1.5	-	1.5	%
Maximum duty cycle		-	66	-	%
Minimum duty cycle		-	0	-	%

ELECTRICAL CHARACTERISTICS (cont'd)

PARAMETER	TEST CONDITIONS	PARAMETERS			UNITS
		MIN.	TYP.	MAX.	
Error amplifier					
Sensitivity in mV / % of PWM		-	54	95	mV
Voltage for max duty cycle	OPTO pin	-	4	-	V
Voltage for min duty cycle	OPTO pin	-	0.5	-	V
Input impedance	OPTO pin	-	60	-	KΩ
P & N Outputs to MOSFET gate					
P gate driver saturation	10 mA (source)	-	-	1	V
N gate driver saturation	10 mA (sink)	-	-	0.6	V
Gate pull-down resistor	(internal)	280	400	520	KΩ
PDRIVE Rise time (10% to 90%)	240 pF load	-	250	-	ns
NDRIVE Fall time (10% to 90%)	240 pF load	-	100	-	ns
Max recommended total external MOSFET charge	@ 20 KHz	-	-	100	nC
“	@ 80 KHz	-	-	50	nC
“	@ 150 KHz	-	-	15	nC

Note: Electrical parameters, although guaranteed, are not all 100% tested in production.

Figure 2: Frequency vs Rbias

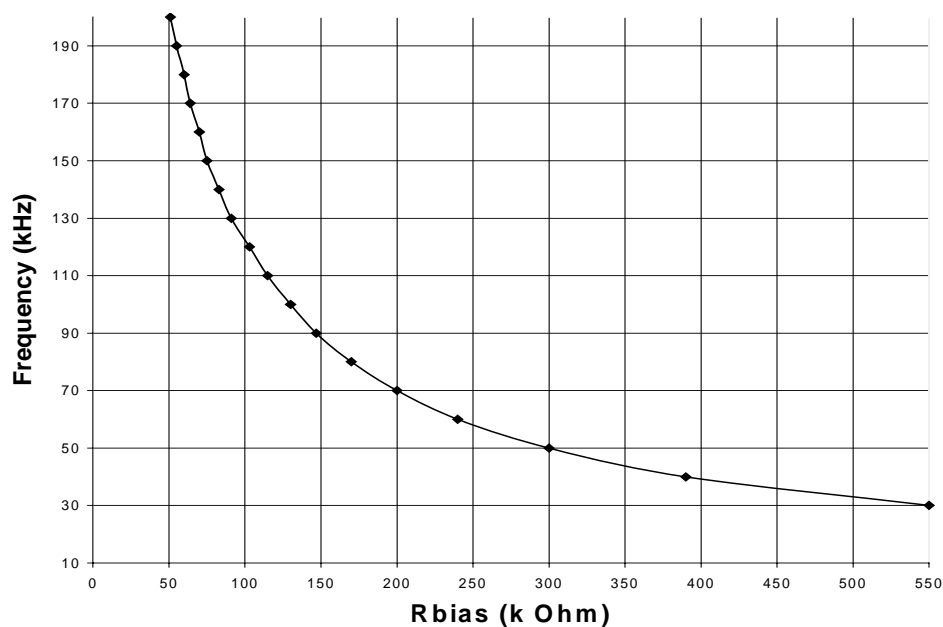

Figure 3 Frequency drift vs temperature

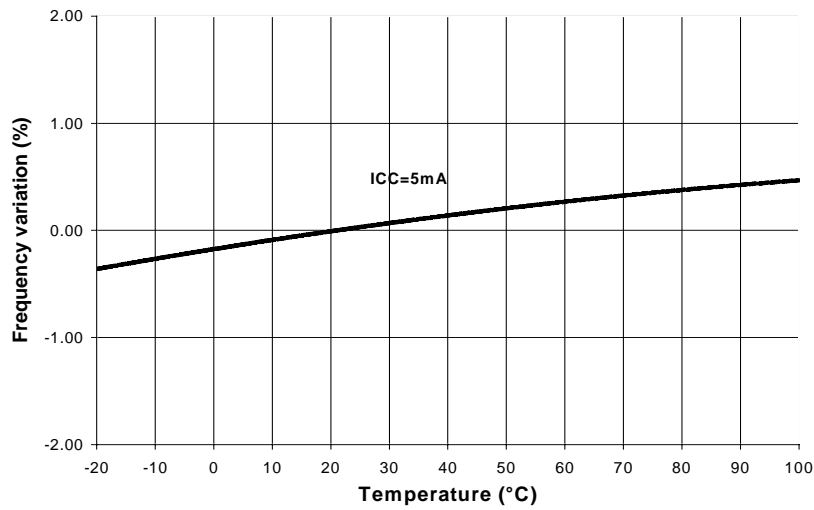
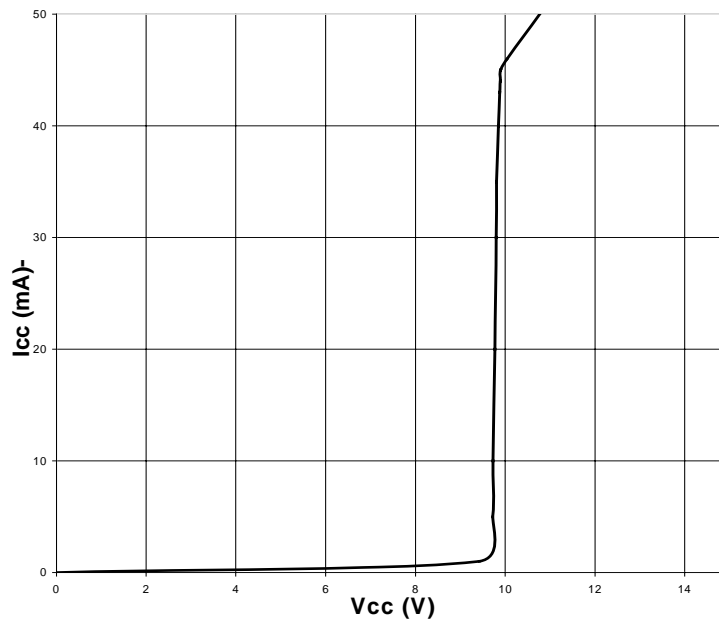

Figure 4 Shunt regulator I_{CC} current



ORDERING INFORMATION

Part No.	ROHS / Pb-Free	Package	Temperature Range		
			Min	Max	
IPS15C-D	-G-LF	8-Pin PDIP	0°C	+70°C	Commercial
IPS15I-D	-G-LF	8-Pin PDIP	-40°C	+85°C	Industrial
IPS15C-SO	-G-LF	8-Pin SOIC	0°C	+70°C	Commercial
IPS15I-SO	-G-LF	8-Pin SOIC	-40°C	+85°C	Industrial

For detailed ordering information, see page 14

GOOD DESIGN PRACTICES

IPS15 and loop stability:

The IPS15 is intrinsically very fast and doesn't participate to the loop stability. It only involves a comparator that doesn't bring any gain and exhibits a negligible phase shift.

It has been designed on purpose to allow its utilization in a large range of applications:

- (a) Operating at frequencies up to 200 kHz and even above,
- (b) Involving very different types of loop stability from "cycle skipping" where the loop is not compensated at all (figure 1), to good stability achieved through the utilization of a TL431 (figure 5) and finally superior transient response when using the IPS25 feedback controller (figure 6).

The loop compensation is entirely achieved on the load side and the feedback is performed by an optocoupler which gain and dynamic response play an important role in the loop stability.

Precaution in selecting the optocoupler:

The optocoupler must be **using a Phototransistor** and **NOT** a Photodarlington. Most optocouplers of this type are offered in a wide range of coupling efficiency, also called transfer ratio. Even the cheapest ones have a guaranteed transfer ratio of the order of 100% meaning that 1mA of current in the IR LED creates approximately 1mA of current in the receiving phototransistor. The user should be able to design the loop to be stable even though the actual transfer ratio differs by more than a factor of 3 (example from 100% to 300% or 50% to 150%).

Unfortunately optocouplers were not designed for low-current applications and this results in very bad speed and saturation characteristics for the phototransistor which could become incredibly slow and create severe loop stability problems should it be allowed to saturate hard in the application (the optocoupler could cause the IPS15 to skip cycles due to the long time required by the opto transistor to go out of saturation).

In the example of figure 5, the output voltage is 10 volts as defined by R15 and R16 and 2.5V at the Pin #1 of the TL431. The cathode of the TL431 can go to a voltage as low as 2 Volts. The IR LED requires approximately 1 Volt which means that the voltage drop across R14 could be up to 6 volts resulting in a maximum current of 700uA. This value is plentiful for the utilization of a broad range of optocouplers and yet small enough to avoid hard saturation.

Loop stability with the TL431:

The TL431 has an enormous DC gain and will not ensure stability unless specific loop-compensation components such as a RC network are added as indicated below.

The RC network should have a cut-off frequency at 100Hz to roll-off the gain at low frequencies but **reach a plateau around 100Hz** and have enough AC gain at twice the line frequency and achieve a good line ripple rejection.

This is achieved by the loop compensation network **C7, R17** of figure 5. The gain rolls off until the impedance of C7 reaches the value of R7. At much higher frequencies, the gain continue to roll-off due to the natural frequency response of the TL431.

The goal is to reach a very low gain at the switching frequency.

If the addition of C7 & R17 with values as shown results in gain is too low, the values of R15 & R16 should be reduced in proportion to lower the impedance at Pin #1 of TL 431. Alternately, if the gain is too high the values of R17 should be reduced and C7 re-adjusted accordingly to maintain the required cut-off frequency.

Criteria to calculate the network :

- 1) R17 must be much higher than the input resistance of TL431 constituted by $R16/R15=5K \rightarrow 68K\Omega$ OK.
- 2) $F=100Hz=1/(2 \times 3.14 \times R17 \times C7)$ gives approximately 22,000 pF for C7.

Discontinuous operation:

Check discontinuous mode of operation of the transformer (see application note AN-IPS02 page 2 for details) to ensure that the Flyback SMPS is indeed operating in discontinuous mode in the entire range of Input Voltages and Output Current. The response of the SMPS drastically changes in continuous mode, it gets considerably slower which requires a totally different loop compensation technique. Remember that it is very difficult to ensure loop

stability with a simple schematic when the SMPS is allowed to transition between Discontinuous and Continuous modes.

MOSFET driver protection:

The MOSFET driver has been sized to be capable of driving power MOSFETs featuring a total gate charge up to 100nC.

The MOSFET should be turned-on relatively slowly and turned-off much faster. As shown below, these 2 parameters can be independently adjusted through the external resistors R10 (pin1) and R10A (pin8).

The minimum value of these resistors should be 50Ω in order to reduce EMI and minimize the noise injection which could result from Miller-capacitance kick-back during transient conditions.

See application note AN-IPS-02 for EMI reduction techniques.

APPLICATION 2: AC IN 85-260V, 5 – 10W OUTPUT, voltage regulation with TL431.

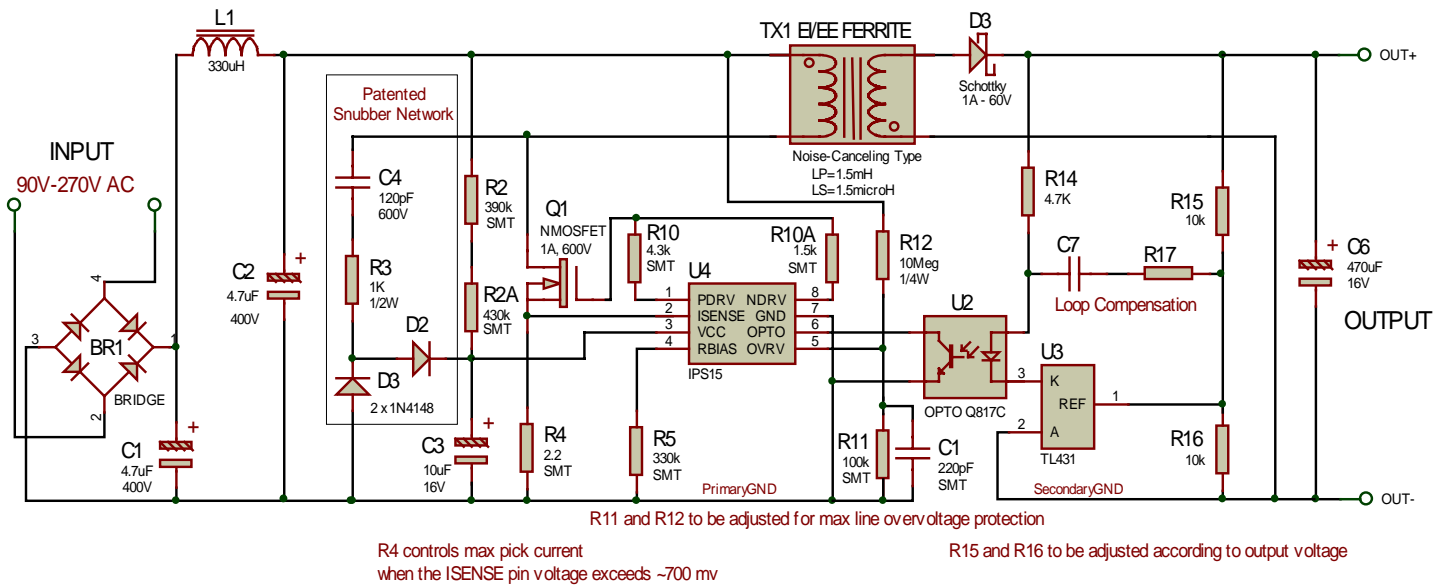

OUTPUT CORD SERIAL RESISTANCE COMPENSATION WITH THE IPS25 FEEDBACK CONTROLLER

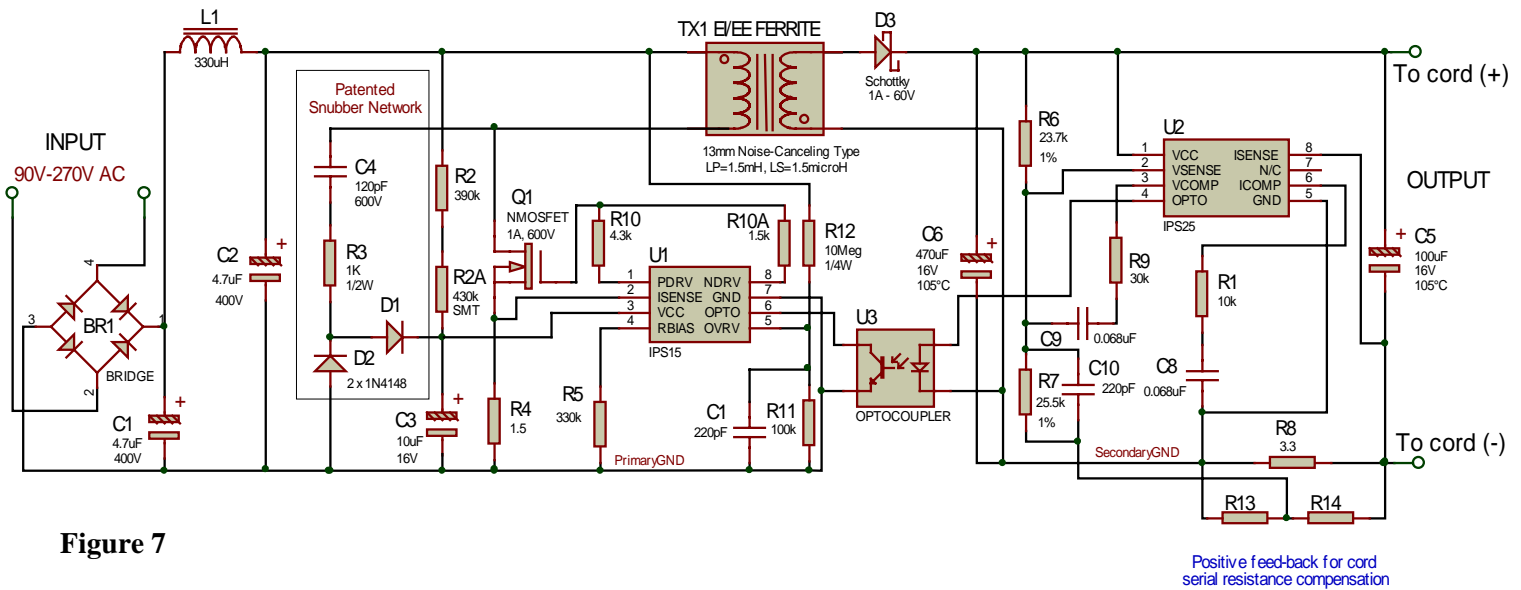

Figure 7

Positive feed-back for cord serial resistance compensation

The voltage drop due to the output serial resistance of the cord can be compensated by adding a voltage positive feedback to the IPS25 input pin VSENSE, proportional to V_{drop} . This can be achieved either by splitting R8 (output current sensing resistor) in two or by inserting 2 serial resistors R13 and R14 in parallel to R8 and connect the positive feedback to the intermediate node.

R13 and R14 should be calculated, based on the following conditions:

- $(R13 + R14) \geq 20 \times R8$ (but should remain low impedance in regards to R7),
- $V_{int} \sim V_{drop}$, where V_{int} is the intermediate voltage measured on the common node of R13 and R14, and V_{drop} is the voltage drop across the cord serial resistor.



SMPS with output cord

ADDITIONAL RECOMMENDATIONS:

For best results in low power off-line SMPSs with the **IPS15**, the following MOSFET features are recommended:

- Low gate charge (max 50 nC).
- 400 V breakdown voltage for domestic use (USA / Japan).
- 600V breakdown voltage for European use (800V when transformer leakage inductance is very small).
- 1, 2 or 3A depending on the maximum output power.

Examples of suitable MOSFETS:

- **IXYS PolarHT™ and Polar HV™** MOSFET series: IXTY1R4N60P, IXTY2N60P, IXTY3N60P
- **Fairchild** MOSFET series: FQPF1N60, FQPF 2N60, FQPF 3N60.
- **Infineon COOLMOS™** series: SPD01N60S5, SPD02N60S5, SPD03N60S5.
- **Motorola** MOSFET series: MTP1N60, MTP2N60, MTP3N60.
- **SGS-Thomson** MOSFET series: STD1NB60, STD2NB60, STD3NB60.
- **Etc...**

Notes:

- Due to the rapid evolution of MOSFET technologies, please check for current models when designing a new SMPS.
- **PolarHT™ and Polar HV™** are trademarks of IXYS corporation
- **COOLMOS™** is a trademark of Infineon.

TRANSFORMER CHARACTERISTICS:

(a) Transformer design:

E-core with suitable gap to prevent saturation or distributed-gap toroid. Primary inductance of 1.5 mH is very typical.

Turn ratio = 9 for 220V input or universal 85V – 265V.

Turn ratio = 7 for 100-120V AC input (Japan and USA)

(b) Transformer phasing:

Check the phase as indicated in figure 1 , 5 and 6. Also refer to application notes AN-IPS-01 and AN-IPS-02.

SNUBBER NETWORK:

With reference to figure 1, R2 provide the start-up current for the chip. C3 is being charged through R2. Once the chip supply voltage is high enough, the gate drive starts and the chip is then powered by the modified snubber network patented by our company.

The snubber values may have to be optimized for different specific operating conditions:

- R3 could be reduced to 100 ohms and sometimes eliminated.
- C4 could be increased to 200pF and sometimes more.

Depending on the characteristics of the transformer, essentially leakage inductance and distributed capacitance, the snubber network shown in figure 1, may not be efficient enough to reduce the voltage spikes when operating at 20W or above. Please refer to applications notes AN-IPS-01 and AN-IPS-02 design tips or EMI reduction techniques, or feel free to contact our technical support for assistance.

POWER SHUT-DOWN SOLUTIONS for STAND-BY REQUIREMENTS:

For low-power stand-by requirements, the primary circuitry can be shut-down by pulling the IPS15 VCC pin “LOW” through a 100Ω resistor.

This can be easily done using a:

- Simple switch
- PNP transistor
- NPN transistor

SHUT-DOWN SOLUTIONS

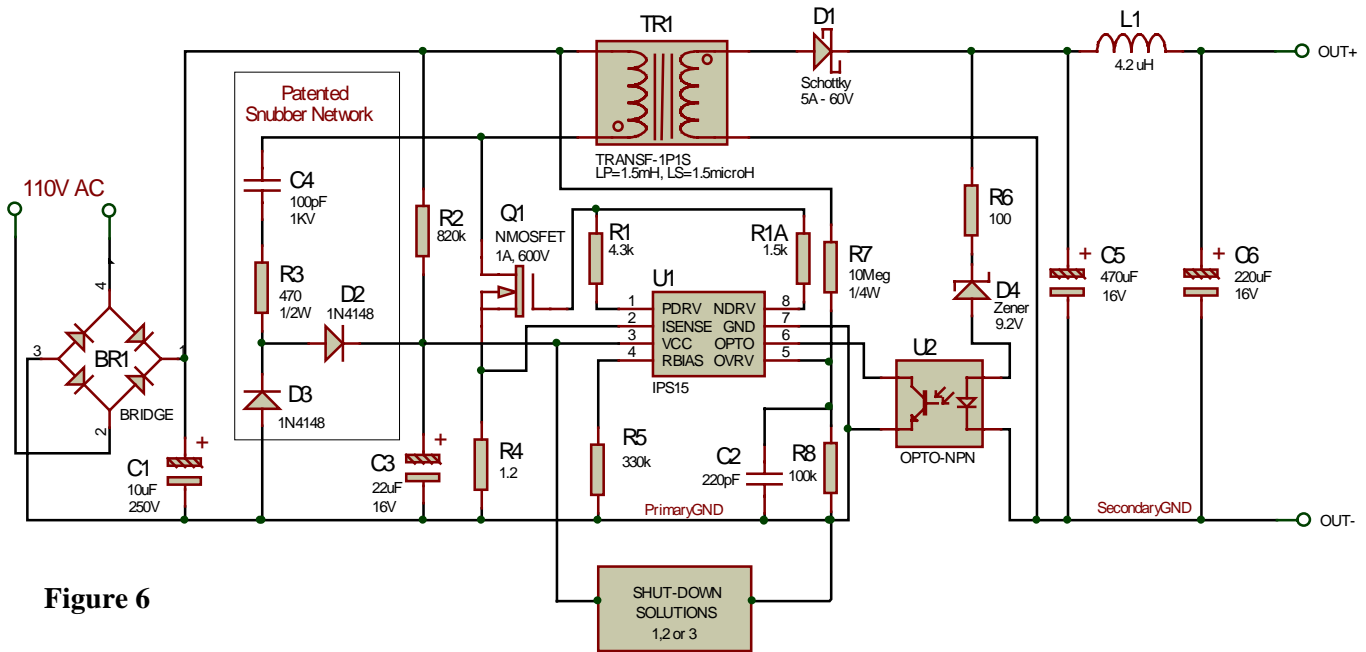
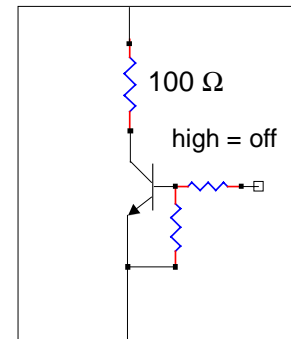
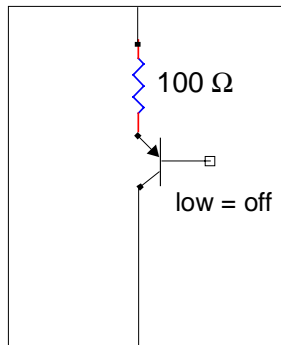
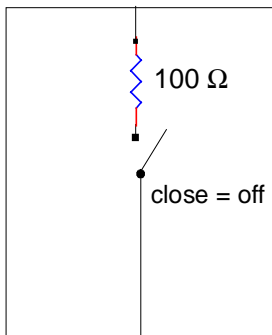

Figure 6

Solution 1:
 simple switch, close = off
 100Ω resistor
 mandatory

Solution 2:
 PNP transistor, low = off
 (low = less than 4V)
 100Ω resistor
 optional

Solution 3:
 NPN transistor, high = off
 100Ω resistor
 optional



When the "LOW" state is released, the VCC is naturally re-established, re-activating the IPS15.

PACKAGE DIMENSIONS

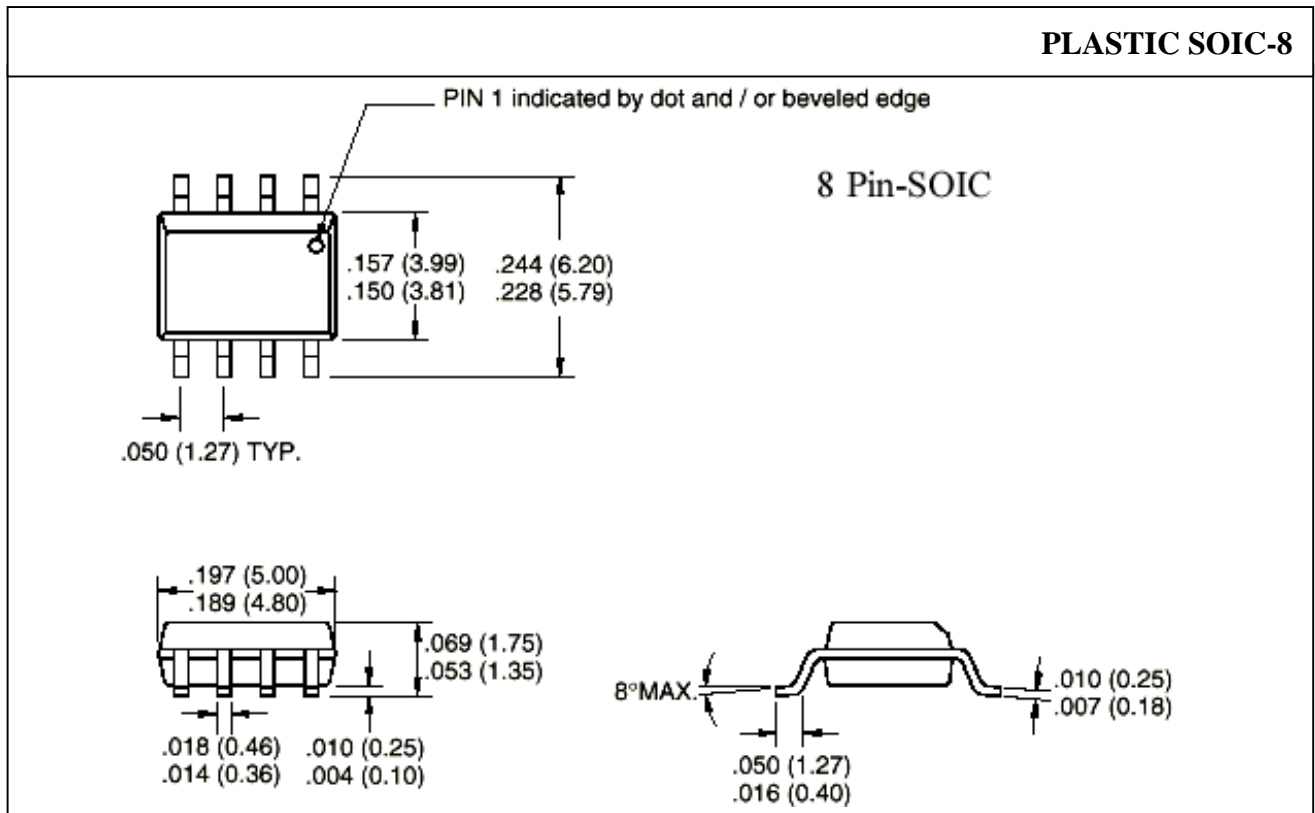
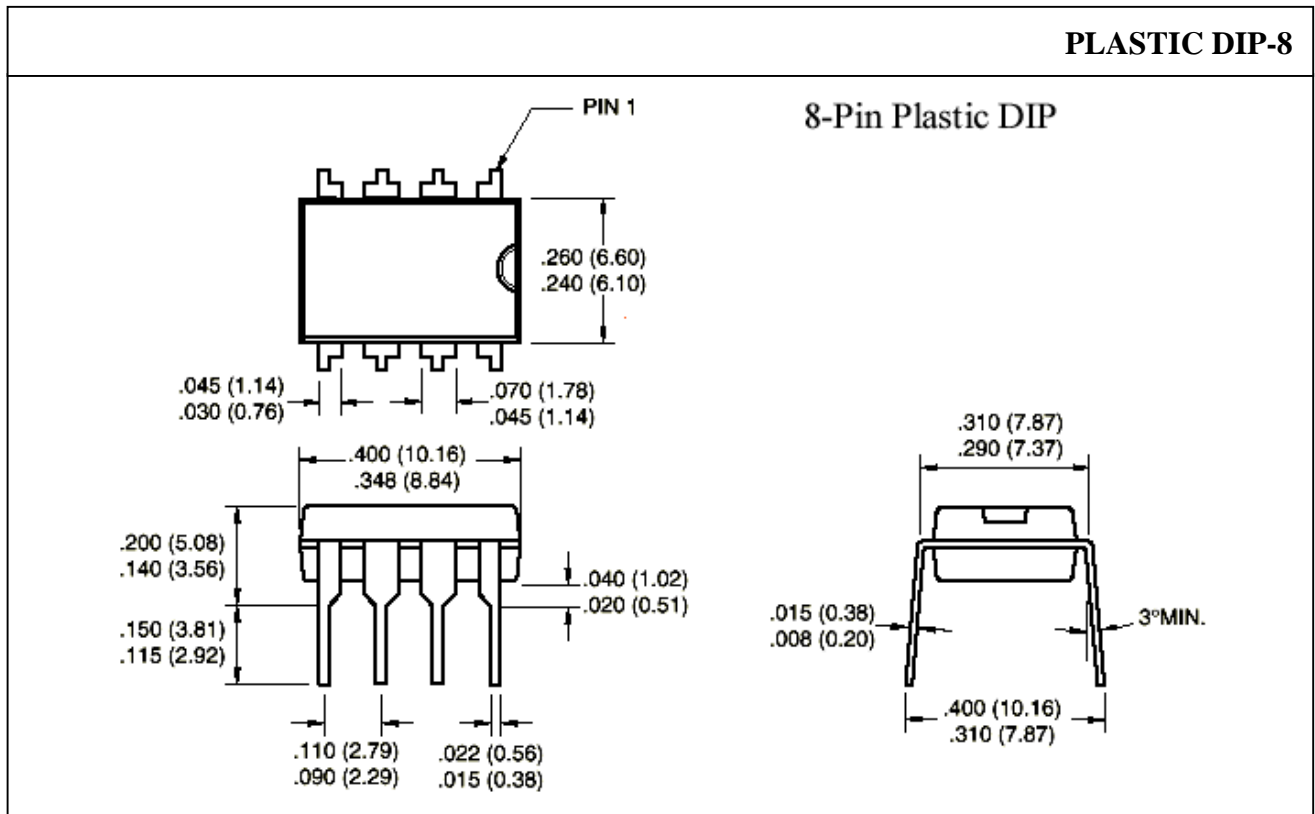

ORDERING INFORMATION

Part-Number

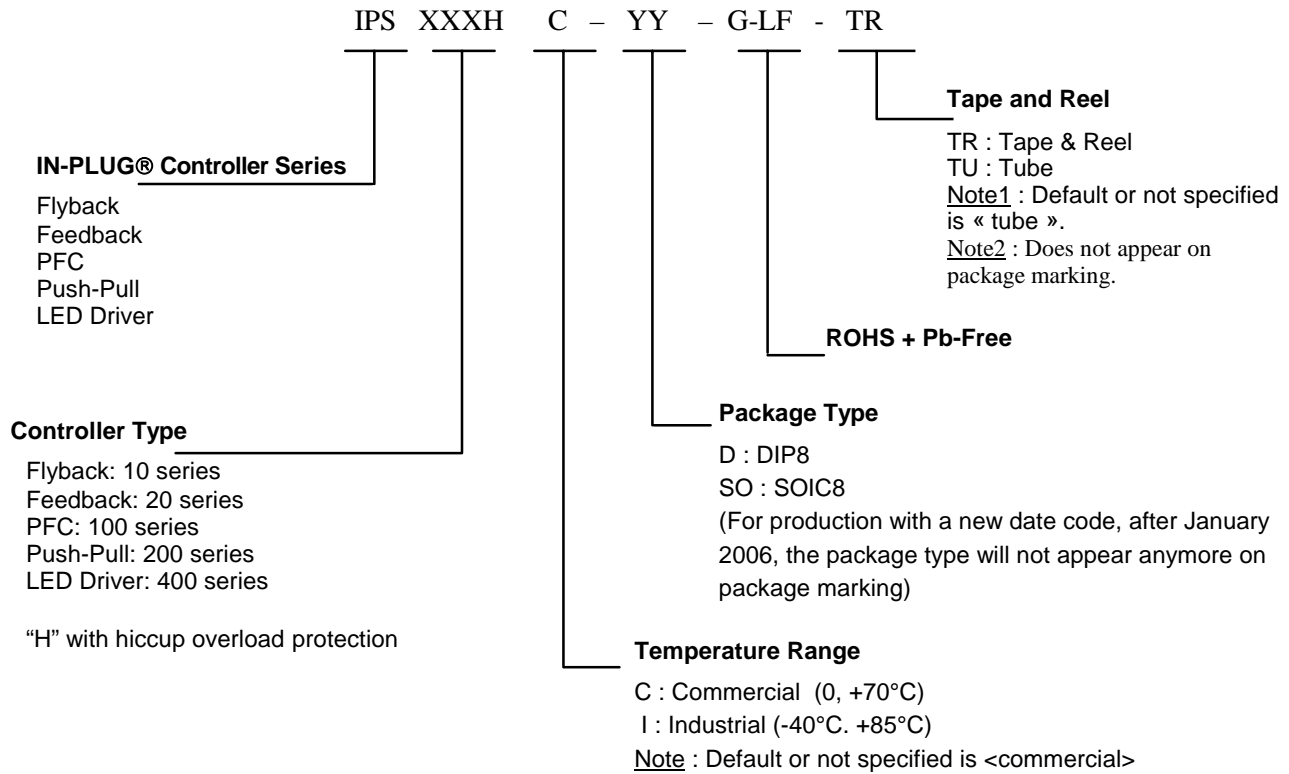

Example of Marking



Non-Green Package

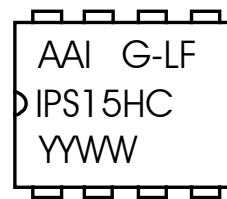

Green ROHS + Pb-Free Package

(Note : For production with a new date code, since January 2006, the package type does not appear anymore on package marking)

This ordering information is for commercial and industrial standard IN-PLUG® controllers ONLY. For custom controllers or for automotive and military temperature ranges, call AAI's sales representative.

The following is a brief overview of certain terms and conditions of sale of product. For a full and complete copy of all the General Terms and Conditions of Sale, visit our webpage <http://www.asicadvantage.com/terms.htm>.

LIMITED WARRANTY

The product is warranted that it will conform to the applicable specifications and be free of defects for one year. Buyer is responsible for selection of, use of and results obtained from use of the product. Buyer indemnifies and holds ASIC Advantage, Inc. harmless for claims arising out of the application of ASIC Advantage, Inc.'s products to Buyer's designs. Applications described herein or in any catalogs, advertisements or other documents are for illustrative purposes only.

CRITICAL APPLICATIONS

Products are not authorized for use in critical applications including aerospace and life support applications. Use of products in these applications is fully at the risk of the Buyer. Critical applications include any system or device whose failure to perform can result in significant injury to the user.

LETHAL VOLTAGES

Lethal voltages could be present in the applications. Please comply with all applicable safety regulations.

INTELLECTUAL PROPERTY RIGHTS AND PROPRIETARY DATA

ASIC Advantage, Inc. retains all intellectual property rights in the products. Sale of products does not confer on Buyer any license to the intellectual property. ASIC Advantage, Inc. reserves the right to make changes without notice to the products at any time. Buyer agrees not to use or disclose ASIC Advantage Inc.'s proprietary information without written consent.

TRADEMARKS AND PATENTS

- IN-PLUG® is a registered trademark of ASIC Advantage, Inc.
- AAI's modified snubber network is patented under the US Patent # 6,233,165. IN-PLUG® Customers are granted a royalty-free licence for its utilization, provision the parts are purchased factory direct or from an authorized agent.

PROTECTION FOR CUSTOM IN-PLUG® SOLUTIONS

When AAI accepts to design and manufacture IN-PLUG® products to Buyer's designs or specifications, buyer has certain obligations to provide defense in a suit or proceeding claiming infringement of a patent, copyright or trademark or for misappropriation of use of any trade secrets or for unfair competition.

COMPLIANCE WITH LAWS

Buyer agrees that at all times it will comply with all applicable federal, state, municipal, and local laws, orders and regulations. Buyer agrees to comply with all applicable restrictions on exports and re-exports including obtaining any required U.S. Government license, authorization, or approval. Buyer shall pay any duties, levies, taxes, brokerage fees, or customs fees imposed on the products.

TITLE AND DELIVERY

All shipments of goods shall be delivered ExWorks, Sunnyvale, CA, U.S.A. Title in the goods shall not pass to Buyer until ASIC Advantage, Inc. has received in full all amounts owed by Buyer.

LATEST DATASHEET UPDATES

For the latest datasheet updates, visit our web page: <http://www.in-plug.com/datasheets.htm>.

WORLDWIDE REPRESENTATIVES

To access AAI's list of worldwide representatives, visit our web page <http://www.in-plug.com/representatives.htm>

COPYRIGHTS

Copyrights and all other proprietary rights in the Content rests with ASIC Advantage Inc. (AAI) or its licensors. All rights in the Content not expressly granted herein are reserved. Except as otherwise provided, the Content published on this document may be reproduced or distributed in unmodified form for personal non-commercial use only. Any other use of the Content, including without limitation distribution, reproduction, modification, display or transmission without the prior written consent of AAI is strictly prohibited. All copyright and other proprietary notices shall be retained on all reproductions.

ASIC Advantage INC.

1290-B Reamwood Ave, Sunnyvale California 94089, USA

Tel: (1) 408-541-8686 Fax: (1) 408-541-8675

Websites: <http://www.in-plug.com> - <http://www.asicadvantage.com>

Looking for pricing, stock, or lifecycle information?

Click below to explore more details on WIN SOURCE:

-  [View IPS15C-SO-G-LF-T on WIN SOURCE](#)
-  [Microsemi Corporation](#) Information

Optimize Your Supply Chain with WIN SOURCE Solutions

-  Global Sourcing Solution
-  Obsolete Management
-  Cost Control Management
-  Shortage Management
-  Alternative Solution
-  Excess Inventory Management