



THE DATASHEET OF NRF52810-QCAA-R7



nRF52810

Product Specification

v1.3

Feature list

Features:

- 2.4 GHz transceiver
 - -96 dBm sensitivity in *Bluetooth*[®] low energy mode
 - Supported data rates: 1 Mbps, 2 Mbps *Bluetooth*[®] low energy mode
 - -20 to +4 dBm TX power, configurable in 4 dB steps
 - On-chip balun (single-ended RF)
 - 4.6 mA peak current in TX (0 dBm)
 - 4.6 mA peak current in RX
 - RSSI (1 dB resolution)
- ARM[®] Cortex[®]-M4 32-bit processor, 64 MHz
 - 144 EEMBC CoreMark[®] score running from flash memory
 - 34.4 μ A/MHz running CoreMark from flash memory
 - 32.8 μ A/MHz running CoreMark from RAM memory
 - Serial wire debug (SWD)
- Flexible power management
 - 1.7 V to 3.6 V supply voltage range
 - Fully automatic LDO and DC/DC regulator system
 - Fast wake-up using 64 MHz internal oscillator
 - 0.3 μ A at 3 V in System OFF mode, no RAM retention
 - 0.5 μ A at 3 V in System OFF mode with full 24 kB RAM retention
 - 1.5 μ A at 3 V in System ON mode, with full 24 kB RAM retention, wake on RTC
 - 1.4 μ A at 3 V in System ON mode, no RAM retention, wake on RTC
- 192 kB flash and 24 kB RAM
- Nordic SoftDevice ready
- Support for concurrent multi-protocol
- 12-bit, 200 ksps ADC - 8 configurable channels with programmable gain
- 64 level comparator
- Temperature sensor
- Up to 32 general purpose I/O pins
- 4-channel pulse width modulator (PWM) unit with EasyDMA
- Digital microphone interface (PDM)
- 3x 32-bit timer with counter mode
- SPI master/slave with EasyDMA
- I2C compatible 2-wire master/slave
- UART (CTS/RTS) with EasyDMA
- Programmable peripheral interconnect (PPI)
- Quadrature decoder (QDEC)
- AES HW encryption with EasyDMA
- 2x real-time counter (RTC)
- Single crystal operation
- Package variants
 - QFN48 package, 6 x 6 mm
 - QFN32 package, 5 x 5 mm
 - WLCSP package, 2.482 x 2.464 mm

Applications:

- Computer peripherals and I/O devices
 - Mouse
 - Keyboard
 - Mobile HID
- CE remote controls
- Network processor
 - Wearables
 - Virtual reality headsets
- Health and medical
- Enterprise lighting
 - Industrial
 - Commercial
 - Retail
- Beacons
- Connectivity device in multi-chip solutions

Contents

Feature list	ii
1 Revision history	10
2 About this document	12
2.1 Document naming and status	12
2.2 Peripheral naming and abbreviations	12
2.3 Register tables	13
2.3.1 Fields and values	13
2.4 Registers	13
2.4.1 DUMMY	13
3 Block diagram	15
4 Core components	16
4.1 CPU	16
4.1.1 Electrical specification	16
4.1.2 CPU and support module configuration	16
4.2 Memory	17
4.2.1 RAM - Random access memory	18
4.2.2 Flash - Non-volatile memory	18
4.2.3 Memory map	18
4.2.4 Instantiation	19
4.3 NVMC — Non-volatile memory controller	20
4.3.1 Writing to flash	20
4.3.2 Erasing a page in flash	20
4.3.3 Writing to user information configuration registers (UICR)	21
4.3.4 Erasing user information configuration registers (UICR)	21
4.3.5 Erase all	21
4.3.6 Partial erase of a page in flash	21
4.3.7 Registers	21
4.3.8 Electrical specification	25
4.4 FICR — Factory information configuration registers	25
4.4.1 Registers	25
4.5 UICR — User information configuration registers	33
4.5.1 Registers	33
4.6 EasyDMA	36
4.6.1 EasyDMA error handling	37
4.6.2 EasyDMA array list	38
4.7 AHB multilayer	38
4.8 Debug	39
4.8.1 DAP - Debug access port	40
4.8.2 CTRL-AP - Control access port	40
4.8.3 Debug interface mode	42
4.8.4 Real-time debug	42
5 Power and clock management	43
5.1 Power management unit (PMU)	43
5.2 Current consumption	43

5.2.1 Electrical specification	44
5.3 POWER — Power supply	49
5.3.1 Regulators	49
5.3.2 System OFF mode	50
5.3.3 System ON mode	51
5.3.4 Power supply supervisor	51
5.3.5 RAM power control	53
5.3.6 Reset	53
5.3.7 Retained registers	54
5.3.8 Reset behavior	54
5.3.9 Registers	55
5.3.10 Electrical specification	61
5.4 CLOCK — Clock control	62
5.4.1 HFCLK clock controller	63
5.4.2 LFCLK clock controller	64
5.4.3 Registers	67
5.4.4 Electrical specification	73
6 Peripherals	75
6.1 Peripheral interface	75
6.1.1 Peripheral ID	75
6.1.2 Peripherals with shared ID	76
6.1.3 Peripheral registers	76
6.1.4 Bit set and clear	76
6.1.5 Tasks	76
6.1.6 Events	76
6.1.7 Shortcuts	77
6.1.8 Interrupts	77
6.2 AAR — Accelerated address resolver	78
6.2.1 EasyDMA	78
6.2.2 Resolving a resolvable address	78
6.2.3 Use case example for chaining RADIO packet reception with address resolution using AAR	79
6.2.4 IRK data structure	79
6.2.5 Registers	79
6.2.6 Electrical specification	83
6.3 BPROT — Block protection	83
6.3.1 Registers	85
6.4 CCM — AES CCM mode encryption	86
6.4.1 Key-stream generation	86
6.4.2 Encryption	87
6.4.3 Decryption	87
6.4.4 AES CCM and RADIO concurrent operation	88
6.4.5 Encrypting packets on-the-fly in radio transmit mode	88
6.4.6 Decrypting packets on-the-fly in radio receive mode	89
6.4.7 CCM data structure	90
6.4.8 EasyDMA and ERROR event	91
6.4.9 Registers	91
6.4.10 Electrical specification	98
6.5 COMP — Comparator	98
6.5.1 Differential mode	100
6.5.2 Single-ended mode	100
6.5.3 Registers	102
6.5.4 Electrical specification	109
6.6 ECB — AES electronic codebook mode encryption	110

6.6.1 Shared resources	110
6.6.2 EasyDMA	110
6.6.3 ECB data structure	110
6.6.4 Registers	111
6.6.5 Electrical specification	113
6.7 EGU — Event generator unit	113
6.7.1 Registers	114
6.7.2 Electrical specification	116
6.8 GPIO — General purpose input/output	116
6.8.1 Pin configuration	117
6.8.2 Registers	118
6.8.3 Electrical specification	123
6.9 GPIOTE — GPIO tasks and events	124
6.9.1 Pin events and tasks	124
6.9.2 Port event	125
6.9.3 Tasks and events pin configuration	125
6.9.4 Registers	126
6.9.5 Electrical specification	130
6.10 PDM — Pulse density modulation interface	130
6.10.1 Master clock generator	130
6.10.2 Module operation	130
6.10.3 Decimation filter	131
6.10.4 EasyDMA	131
6.10.5 Hardware example	132
6.10.6 Pin configuration	133
6.10.7 Registers	133
6.10.8 Electrical specification	139
6.11 PPI — Programmable peripheral interconnect	140
6.11.1 Pre-programmed channels	141
6.11.2 Registers	142
6.12 PWM — Pulse width modulation	146
6.12.1 Wave counter	147
6.12.2 Decoder with EasyDMA	150
6.12.3 Limitations	157
6.12.4 Pin configuration	157
6.12.5 Registers	158
6.13 QDEC — Quadrature decoder	166
6.13.1 Sampling and decoding	167
6.13.2 LED output	168
6.13.3 Debounce filters	168
6.13.4 Accumulators	169
6.13.5 Output/input pins	169
6.13.6 Pin configuration	169
6.13.7 Registers	170
6.13.8 Electrical specification	181
6.14 RADIO — 2.4 GHz radio	181
6.14.1 EasyDMA	181
6.14.2 Packet configuration	182
6.14.3 Maximum packet length	183
6.14.4 Address configuration	183
6.14.5 Data whitening	184
6.14.6 CRC	184
6.14.7 Radio states	185
6.14.8 Transmit sequence	186

6.14.9 Receive sequence	187
6.14.10 Received signal strength indicator (RSSI)	189
6.14.11 Interframe spacing	189
6.14.12 Device address match	189
6.14.13 Bit counter	190
6.14.14 Registers	191
6.14.15 Electrical specification	210
6.15 RNG — Random number generator	214
6.15.1 Bias correction	215
6.15.2 Speed	215
6.15.3 Registers	215
6.15.4 Electrical specification	217
6.16 RTC — Real-time counter	218
6.16.1 Clock source	218
6.16.2 Resolution versus overflow and the PRESCALER	218
6.16.3 COUNTER register	219
6.16.4 Overflow features	219
6.16.5 TICK event	220
6.16.6 Event control feature	220
6.16.7 Compare feature	220
6.16.8 TASK and EVENT jitter/delay	222
6.16.9 Reading the COUNTER register	224
6.16.10 Registers	225
6.16.11 Electrical specification	230
6.17 SAADC — Successive approximation analog-to-digital converter	230
6.17.1 Shared resources	230
6.17.2 Overview	230
6.17.3 Digital output	231
6.17.4 Analog inputs and channels	232
6.17.5 Operation modes	232
6.17.6 EasyDMA	234
6.17.7 Resistor ladder	235
6.17.8 Reference	236
6.17.9 Acquisition time	236
6.17.10 Limits event monitoring	237
6.17.11 Registers	238
6.17.12 Electrical specification	252
6.17.13 Performance factors	253
6.18 SPI — Serial peripheral interface master	253
6.18.1 Functional description	254
6.18.2 Registers	257
6.18.3 Electrical specification	260
6.19 SPIM — Serial peripheral interface master with EasyDMA	261
6.19.1 SPI master transaction sequence	262
6.19.2 Master mode pin configuration	263
6.19.3 EasyDMA	264
6.19.4 Low power	264
6.19.5 Registers	264
6.19.6 Electrical specification	273
6.20 SPIS — Serial peripheral interface slave with EasyDMA	274
6.20.1 Shared resources	275
6.20.2 EasyDMA	275
6.20.3 SPI slave operation	275
6.20.4 Pin configuration	277

6.20.5 Registers	278
6.20.6 Electrical specification	289
6.21 SWI — Software interrupts	291
6.21.1 Registers	291
6.22 TEMP — Temperature sensor	291
6.22.1 Registers	291
6.22.2 Electrical specification	297
6.23 TWI — I ² C compatible two-wire interface	298
6.23.1 Functional description	298
6.23.2 Master mode pin configuration	298
6.23.3 Shared resources	299
6.23.4 Master write sequence	299
6.23.5 Master read sequence	300
6.23.6 Master repeated start sequence	301
6.23.7 Low power	302
6.23.8 Registers	302
6.23.9 Electrical specification	309
6.24 TIMER — Timer/counter	310
6.24.1 Capture	312
6.24.2 Compare	312
6.24.3 Task delays	312
6.24.4 Task priority	312
6.24.5 Registers	312
6.25 TWIM — I ² C compatible two-wire interface master with EasyDMA	317
6.25.1 EasyDMA	318
6.25.2 Master write sequence	319
6.25.3 Master read sequence	320
6.25.4 Master repeated start sequence	321
6.25.5 Low power	322
6.25.6 Master mode pin configuration	322
6.25.7 Registers	322
6.25.8 Electrical specification	333
6.25.9 Pullup resistor	334
6.26 TWIS — I ² C compatible two-wire interface slave with EasyDMA	334
6.26.1 EasyDMA	337
6.26.2 TWI slave responding to a read command	337
6.26.3 TWI slave responding to a write command	338
6.26.4 Master repeated start sequence	339
6.26.5 Terminating an ongoing TWI transaction	340
6.26.6 Low power	340
6.26.7 Slave mode pin configuration	340
6.26.8 Registers	341
6.26.9 Electrical specification	351
6.27 UART — Universal asynchronous receiver/transmitter	351
6.27.1 Functional description	352
6.27.2 Pin configuration	352
6.27.3 Shared resources	352
6.27.4 Transmission	352
6.27.5 Reception	353
6.27.6 Suspending the UART	354
6.27.7 Error conditions	354
6.27.8 Using the UART without flow control	354
6.27.9 Parity and stop bit configuration	354
6.27.10 Registers	354

6.27.11 Electrical specification	363
6.28 UARTE — Universal asynchronous receiver/transmitter with EasyDMA	363
6.28.1 EasyDMA	364
6.28.2 Transmission	364
6.28.3 Reception	365
6.28.4 Error conditions	367
6.28.5 Using the UARTE without flow control	367
6.28.6 Parity and stop bit configuration	367
6.28.7 Low power	367
6.28.8 Pin configuration	368
6.28.9 Registers	368
6.28.10 Electrical specification	381
6.29 WDT — Watchdog timer	381
6.29.1 Reload criteria	382
6.29.2 Temporarily pausing the watchdog	382
6.29.3 Watchdog reset	382
6.29.4 Registers	382
6.29.5 Electrical specification	386
7 Hardware and layout	387
7.1 Pin assignments	387
7.1.1 QFN48 pin assignments	387
7.1.2 QFN32 pin assignments	389
7.1.3 WLCSP ball assignments	391
7.1.4 GPIO pins located near the radio	394
7.2 Mechanical specifications	394
7.2.1 QFN48 6 x 6 mm package	394
7.2.2 QFN32 5 x 5 mm package	395
7.2.3 WLCSP 2.482 x 2.464 mm package	395
7.3 Reference circuitry	396
7.3.1 Schematic QFAA QFN48 with internal LDO regulator setup	396
7.3.2 Schematic QFAA QFN48 with DC/DC regulator setup	397
7.3.3 Schematic QCAA QFN32 with internal LDO regulator setup	398
7.3.4 Schematic QCAA QFN32 with DC/DC regulator setup	399
7.3.5 Schematic CAAA WLCSP with internal LDO regulator setup	400
7.3.6 Schematic CAAA WLCSP with DC/DC regulator setup	401
7.3.7 Schematic CAAA WLCSP with two layers	403
7.3.8 PCB guidelines	404
7.3.9 PCB layout example	405
8 Recommended operating conditions	407
8.1 WLCSP light sensitivity	407
9 Absolute maximum ratings	408
10 Ordering information	409
10.1 IC marking	409
10.2 Box labels	409
10.3 Order code	410
10.4 Code ranges and values	411
10.5 Product options	412
11 Legal notices	414

11.1 Liability disclaimer 414
11.2 Life support applications 414
11.3 RoHS and REACH statement 414
11.4 Trademarks 414
11.5 Copyright notice 415



1 Revision history

Date	Version	Description
February 2019	1.3	<p>The following content has been added or updated:</p> <ul style="list-style-type: none">• Legal notices on page 414: Updates to text and image.• Memory on page 17: Added missing chip variants into memory table.• Absolute maximum ratings on page 408: Corrected value for Moisture Sensity Level for WLCSP package.• FICR — Factory information configuration registers on page 25: Added missing WLCSP package to register INFO.PACKAGE.• UICR — User information configuration registers on page 33: Clarified text in PSELRESET registers. Corrected size of field PIN in PSELRESET register.• EasyDMA on page 36: Added section about EasyDMA error handling. Corrected example code in section EasyDMA array list.• SPIM — Serial peripheral interface master with EasyDMA on page 261: Modified the EasyDMA section, linking to the common chapter instead of having the information duplicated in every serial peripheral. Corrected size of LIST register.• SPIS — Serial peripheral interface slave with EasyDMA on page 274: Modified the EasyDMA section, linking to the common chapter instead of having the information duplicated in every serial peripheral. Exposed the LIST register. Corrected SPI modes table, it was wrong.• TWIM — I²C compatible two-wire interface master with EasyDMA on page 317: Modified the EasyDMA section, linking to the common chapter instead of having the information duplicated in every serial peripheral.• TWIS — I²C compatible two-wire interface slave with EasyDMA on page 334: Modified the EasyDMA section, linking to the common chapter instead of having the information duplicated in every serial peripheral. Exposed the LIST register. Corrected some broken links.• UARTE — Universal asynchronous receiver/transmitter with EasyDMA on page 363: Reworded the section Parity and Stop Bit Configuration. Added note for the need of external xtal oscillator for proper accuracy.• RADIO — 2.4 GHz radio on page 181: Added some Min. and Max. values to several electrical specification radio timings, and removed the typical value. Corrected value of parameter $C/I_{2M,co-channel}$.• Exposed old deprecated serial peripherals SPI — Serial peripheral interface master on page 253, TWI — I²C compatible two-wire interface on page 298 and UART

Date	Version	Description
		<p>— Universal asynchronous receiver/transmitter on page 351</p>
May 2018	1.2	<p>The following content has been added or updated:</p> <ul style="list-style-type: none"> • Added documentation for new package variant nRF52810 CAAA WLCSP. See Pin assignments on page 387, Mechanical specifications on page 394, Reference circuitry on page 396, Absolute maximum ratings on page 408 and Ordering information on page 409. • Current consumption on page 43: Added values for RTC running from LFRC (parameter I_{ON_RAMON_RTC}). • Debug on page 39: Added SWDCLK frequency parameter (f_{SWDCLK}) in the electrical specification. • NVMC — Non-volatile memory controller on page 20: Clarified that CPU halts during NVMC write operations, regardless of whether the code is running from flash or RAM. Added partial page erase feature documentation. • CPU on page 16: Changed CM_{FLASH/MA} parameter in the electrical specification from 60 to 65 CoreMark/mA. • TWIM — I²C compatible two-wire interface master with EasyDMA on page 317: Added description of suspend short. • Mechanical specifications on page 394: Corrected mechanical specification drawings for QFN48 and QFN32.
November 2017	1.1	<p>The following content has been added or updated:</p> <ul style="list-style-type: none"> • RADIO — 2.4 GHz radio on page 181: Table "Delay when disabling the RADIO" removed from electrical specifications as it contained duplicate information. Several 2 Mbps Bluetooth[®] low energy mode parameters added. • NVMC — Non-volatile memory controller on page 20: Updated electrical specifications. • TWIM — I²C compatible two-wire interface master with EasyDMA on page 317: Erroneous duplicate range value removed for registers TXD.MAXCNT, TXD.AMOUNT, RXD.MAXCNT and RXD.AMOUNT. • Ordering information on page 409: Updated MOQ numbers for nRF52810-QCAA-R7 and nRF52810-QCAA-R.
September 2017	1.0	First release

2 About this document

This product specification is organized into chapters based on the modules and peripherals that are available in this IC.

The peripheral descriptions are divided into separate sections that include the following information:

- A detailed functional description of the peripheral
- Register configuration for the peripheral
- Electrical specification tables, containing performance data which apply for the operating conditions described in [Recommended operating conditions](#) on page 407.

2.1 Document naming and status

Nordic uses three distinct names for this document, which are reflecting the maturity and the status of the document and its content.

Document name	Description
Objective Product Specification (OPS)	Applies to document versions up to 0.7. This product specification contains target specifications for product development.
Preliminary Product Specification (PPS)	Applies to document versions 0.7 and up to 1.0. This product specification contains preliminary data. Supplementary data may be published from Nordic Semiconductor ASA later.
Product Specification (PS)	Applies to document versions 1.0 and higher. This product specification contains final product specifications. Nordic Semiconductor ASA reserves the right to make changes at any time without notice in order to improve design and supply the best possible product.

Table 1: Defined document names

2.2 Peripheral naming and abbreviations

Every peripheral has a unique capitalized name or an abbreviation of its name, e.g. TIMER, used for identification and reference. This name is used in chapter headings and references, and it will appear in the ARM[®] Cortex[®] Microcontroller Software Interface Standard (CMSIS) hardware abstraction layer to identify the peripheral.

The peripheral instance name, which is different from the peripheral name, is constructed using the peripheral name followed by a numbered postfix, starting with 0, for example, TIMER0. A postfix is normally only used if a peripheral can be instantiated more than once. The peripheral instance name is also used in the CMSIS to identify the peripheral instance.

2.3 Register tables

Individual registers are described using register tables. These tables are built up of two sections. The first three colored rows describe the position and size of the different fields in the register. The following rows describe the fields in more detail.

2.3.1 Fields and values

The **Id (Field Id)** row specifies the bits that belong to the different fields in the register. If a field has enumerated values, then every value will be identified with a unique value id in the **Value Id** column.

A blank space means that the field is reserved and read as undefined, and it also must be written as 0 to secure forward compatibility. If a register is divided into more than one field, a unique field name is specified for each field in the **Field** column. The **Value Id** may be omitted in the single-bit bit fields when values can be substituted with a Boolean type enumerator range, e.g. true/false, disable(d)/enable(d), on/off, and so on.

Values are usually provided as decimal or hexadecimal. Hexadecimal values have a 0x prefix, decimal values have no prefix.

The **Value** column can be populated in the following ways:

- Individual enumerated values, for example 1, 3, 9.
- Range of values, e.g. [0..4], indicating all values from and including 0 and 4.
- Implicit values. If no values are indicated in the **Value** column, all bit combinations are supported, or alternatively the field's translation and limitations are described in the text instead.

If two or more fields are closely related, the **Value Id**, **Value**, and **Description** may be omitted for all but the first field. Subsequent fields will indicate inheritance with '..!.

A feature marked **Deprecated** should not be used for new designs.

2.4 Registers

Register	Offset	Description
DUMMY	0x514	Example of a register controlling a dummy feature

Table 2: Register overview

2.4.1 DUMMY

Address offset: 0x514

Example of a register controlling a dummy feature

Bit number	31 30 29 28 27 26 25 24 23 22 21 20 19 18 17 16 15 14 13 12 11 10 9 8 7 6 5 4 3 2 1 0																														
ID	D D D D									C C C			B						A A												
Reset 0x00050002	0 0 0 0 0 0 0 0 0 0 0 0 0 0 1 0 1 0 0 0 0 0 0 0 0 0 0 0 0 0 0 1 0																														
ID	Acce	Field	Value ID	Value	Description																										
A	RW	FIELD_A			Example of a field with several enumerated values																										
			Disabled	0	The example feature is disabled																										
			NormalMode	1	The example feature is enabled in normal mode																										
			ExtendedMode	2	The example feature is enabled along with extra functionality																										

Bit number		31 30 29 28 27 26 25 24 23 22 21 20 19 18 17 16 15 14 13 12 11 10 9 8 7 6 5 4 3 2 1 0																															
ID		D D D D				C C C			B				A A																				
Reset 0x00050002		0 0 0 0 0 0 0 0 0 0 0 0 0 0 1 0 1 0 1 0																															
ID	Acce	Field	Value ID	Value	Description																												
B	RW	FIELD_B			Example of a deprecated field																												
			Disabled	0	The override feature is disabled																												
			Enabled	1	The override feature is enabled																												
C	RW	FIELD_C			Example of a field with a valid range of values																												
			ValidRange	[2..7]	Example of allowed values for this field																												
D	RW	FIELD_D			Example of a field with no restriction on the values																												

3 Block diagram

This block diagram illustrates the overall system. Arrows with white heads indicate signals that share physical pins with other signals.

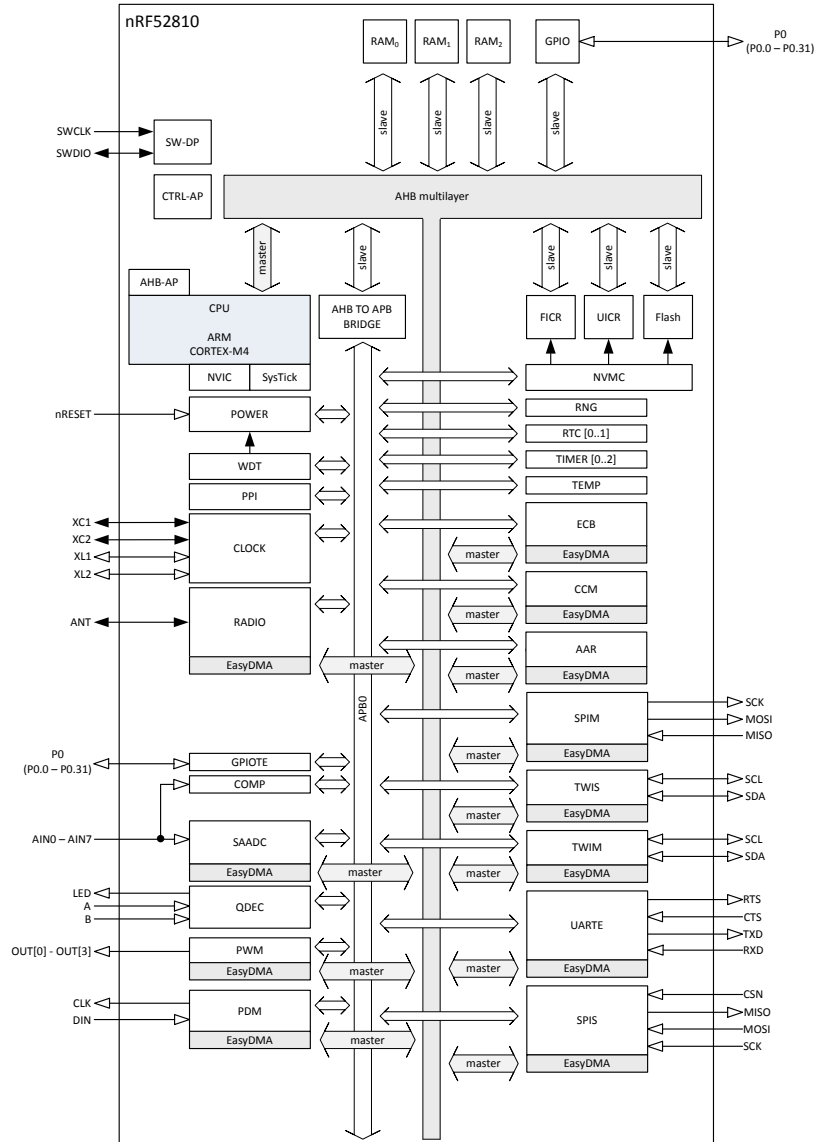

Figure 1: Block diagram

4 Core components

4.1 CPU

The ARM[®] Cortex-M4 processor has a 32-bit instruction set (Thumb[®]-2 technology) that implements a superset of 16- and 32-bit instructions to maximize code density and performance.

This processor implements several features that enable energy-efficient arithmetic and high-performance signal processing including:

- Digital signal processing (DSP) instructions
- Single-cycle multiply and accumulate (MAC) instructions
- Hardware divide
- 8 and 16-bit single instruction multiple data (SIMD) instructions

The ARM Cortex Microcontroller Software Interface Standard (CMSIS) hardware abstraction layer for the ARM Cortex processor series is implemented and available for the M4 CPU.

Real-time execution is highly deterministic in thread mode, to and from sleep modes, and when handling events at configurable priority levels via the nested vectored interrupt controller (NVIC).

Executing code from flash will have a wait state penalty on the nRF52 Series. The section [Electrical specification](#) on page 16 shows CPU performance parameters including wait states in different modes, CPU current and efficiency, and processing power and efficiency based on the CoreMark[®] benchmark.

The ARM System Timer (SysTick) is present on the device. The SysTick's clock will only tick when the CPU is running or when the system is in debug interface mode.

4.1.1 Electrical specification

4.1.1.1 CPU performance

The CPU clock speed is 64 MHz. Current and efficiency data is taken when in System ON and the CPU is executing the CoreMark[®] benchmark. It includes power regulator and clock base currents. All other blocks are IDLE.

Symbol	Description	Min.	Typ.	Max.	Units
W _{FLASH}	CPU wait states, running from flash	0		2	
W _{RAM}	CPU wait states, running from RAM			0	
CM _{FLASH}	CoreMark ¹ , running from flash		144		CoreMark
CM _{FLASH/MHz}	CoreMark per MHz, running from flash		2.25		CoreMark/ MHz
CM _{FLASH/mA}	CoreMark per mA, running from flash, DCDC 3V		65		CoreMark/ mA

4.1.2 CPU and support module configuration

The ARM[®] Cortex[®]-M4 processor has a number of CPU options and support modules implemented on the device.

¹ Using IAR v6.50.1.4452 with flags --endian=little --cpu=Cortex-M4 -e --fpu=VFPv4_sp -Ohs --no_size_constraints

Option / Module	Description	Implemented
Core options		
NVIC	Nested vector interrupt controller	30 vectors
PRIORITIES	Priority bits	3
WIC	Wakeup interrupt controller	NO
Endianness	Memory system endianness	Little endian
Bit-banding	Bit banded memory	NO
DWT	Data watchpoint and trace	NO
SysTick	System tick timer	YES
Modules		
MPU	Memory protection unit	YES
FPU	Floating-point unit	NO
DAP	Debug access port	YES
ETM	Embedded trace macrocell	NO
ITM	Instrumentation trace macrocell	NO
TPIU	Trace port interface unit	NO
ETB	Embedded trace buffer	NO
FPB	Flash patch and breakpoint unit	YES
HTM	AMBA [®] AHB trace macrocell	NO

4.2 Memory

The nRF52810 contains flash and RAM that can be used for code and data storage.

The amount of RAM and flash will vary depending on variant, see [Memory variants](#) on page 17.

Device name	RAM	Flash	Comments
nRF52810-QFAA	24 kB	192 kB	
nRF52810-QCAA	24 kB	192 kB	
nRF52810-CAAA	24 kB	192 kB	

Table 3: Memory variants

The CPU and peripherals with EasyDMA can access memory via the AHB multilayer interconnect. The CPU is also able to access peripherals via the AHB multilayer interconnect, as illustrated in [Memory layout](#) on page 18.

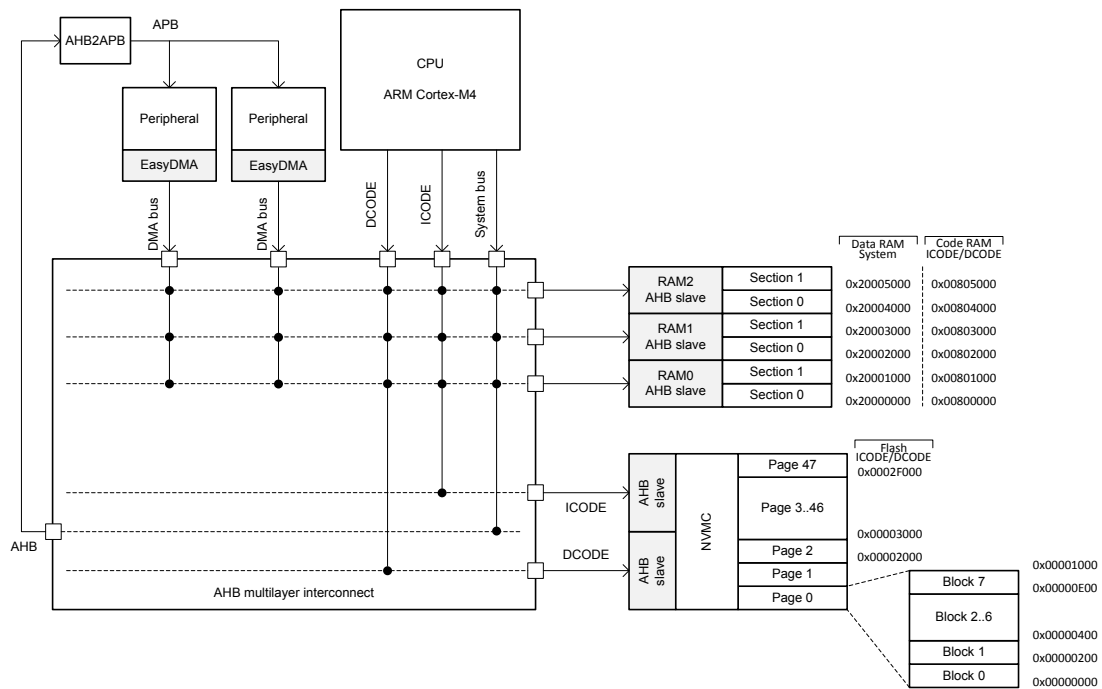

Figure 2: Memory layout

See [AHB multilayer](#) on page 38 and [EasyDMA](#) on page 36 for more information about the AHB multilayer interconnect and the EasyDMA.

The same physical RAM is mapped to both the Data RAM region and the Code RAM region. It is up to the application to partition the RAM within these regions so that one does not corrupt the other.

4.2.1 RAM - Random access memory

The RAM interface is divided into multiple RAM AHB slaves.

Each RAM AHB slave is connected to two 4-kilobyte RAM sections, see Section 0 and Section 1 in [Memory layout](#) on page 18.

Each of the RAM sections have separate power control for System ON and System OFF mode operation, which is configured via RAM register (see the [POWER — Power supply](#) on page 49).

4.2.2 Flash - Non-volatile memory

The flash can be read an unlimited number of times by the CPU, but it has restrictions on the number of times it can be written and erased, and also on how it can be written.

Writing to flash is managed by the non-volatile memory controller (NVMC), see [NVMC — Non-volatile memory controller](#) on page 20.

The flash is divided into multiple 4 kB pages that can be accessed by the CPU via both the ICODE and DCODE buses as shown in, [Memory layout](#) on page 18. Each page is divided into 8 blocks.

4.2.3 Memory map

The complete memory map is shown in [Memory map](#) on page 19. As described in [Memory](#) on page 17, Code RAM and Data RAM are the same physical RAM.

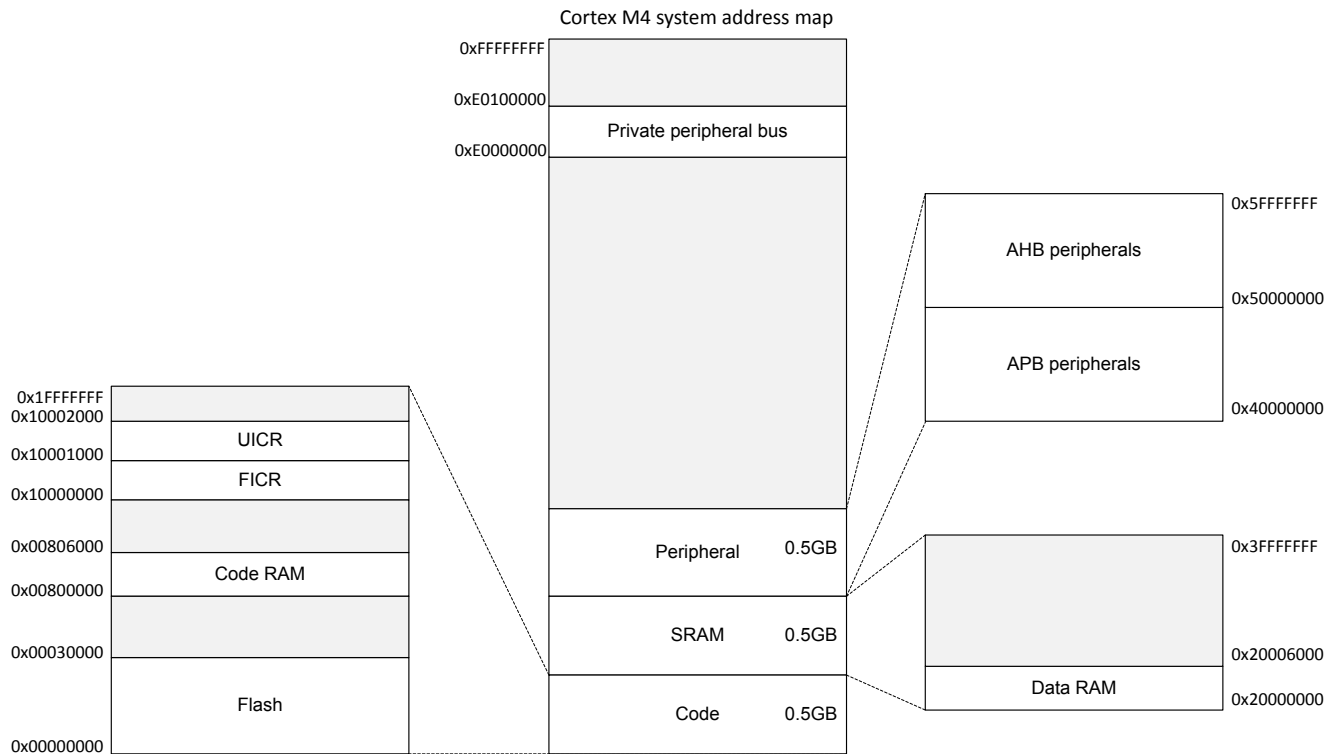

Figure 3: Memory map

4.2.4 Instantiation

ID	Base address	Peripheral	Instance	Description	
0	0x40000000	BPROT	BPROT	Block protect	
0	0x40000000	CLOCK	CLOCK	Clock control	
0	0x40000000	POWER	POWER	Power control	
0	0x50000000	GPIO	PO	General purpose input and output	
1	0x40001000	RADIO	RADIO	2.4 GHz radio	
2	0x40002000	UART	UART0	Universal asynchronous receiver/transmitter	Deprecated
2	0x40002000	UARTE	UARTE0	Universal asynchronous receiver/transmitter with EasyDMA	
3	0x40003000	TWI	TWI0	Two-wire interface master	Deprecated
3	0x40003000	TWIM	TWIM0	Two-wire interface master	
3	0x40003000	TWIS	TWIS0	Two-wire interface slave	
4	0x40004000	SPI	SPI0	SPI master	Deprecated
4	0x40004000	SPIM	SPIM0	SPI master	
4	0x40004000	SPIS	SPIS0	SPI slave	
6	0x40006000	GPIOE	GPIOE	GPIO tasks and events	
7	0x40007000	SAADC	SAADC	Analog-to-digital converter	
8	0x40008000	TIMER	TIMER0	Timer 0	
9	0x40009000	TIMER	TIMER1	Timer 1	
10	0x4000A000	TIMER	TIMER2	Timer 2	
11	0x4000B000	RTC	RTC0	Real-time counter 0	
12	0x4000C000	TEMP	TEMP	Temperature sensor	
13	0x4000D000	RNG	RNG	Random number generator	
14	0x4000E000	ECB	ECB	AES Electronic Codebook (ECB) mode block encryption	
15	0x4000F000	AAR	AAR	Accelerated address resolver	
15	0x4000F000	CCM	CCM	AES CCM mode encryption	
16	0x40010000	WDT	WDT	Watchdog timer	
17	0x40011000	RTC	RTC1	Real-time counter 1	

ID	Base address	Peripheral	Instance	Description
18	0x40012000	QDEC	QDEC	Quadrature decoder
19	0x40013000	COMP	COMP	General purpose comparator
20	0x40014000	EGU	EGU0	Event generator unit 0
20	0x40014000	SWI	SWI0	Software interrupt 0
21	0x40015000	EGU	EGU1	Event generator unit 1
21	0x40015000	SWI	SWI1	Software interrupt 1
22	0x40016000	SWI	SWI2	Software interrupt 2
23	0x40017000	SWI	SWI3	Software interrupt 3
24	0x40018000	SWI	SWI4	Software interrupt 4
25	0x40019000	SWI	SWI5	Software interrupt 5
28	0x4001C000	PWM	PWM0	Pulse-width modulation unit 0
29	0x4001D000	PDM	PDM	Pulse-density modulation (digital microphone interface)
30	0x4001E000	NVMC	NVMC	Non-volatile memory controller
31	0x4001F000	PPI	PPI	Programmable peripheral interconnect
N/A	0x10000000	FICR	FICR	Factory information configuration
N/A	0x10001000	UICR	UICR	User information configuration

Table 4: Instantiation table

4.3 NVMC — Non-volatile memory controller

The non-volatile memory controller (NVMC) is used for writing and erasing of the internal flash memory and the UICR (user information configuration registers).

The [CONFIG](#) on page 22 is used to enable the NVMC for writing (CONFIG.WEN) and erasing (CONFIG.EEN). The user must make sure that writing and erasing are not enabled at the same time. Having both enabled at the same time may result in unpredictable behavior.

The CPU must be halted before initiating a NVMC operation from the debug system.

4.3.1 Writing to flash

When writing is enabled, full 32-bit words are written to word-aligned addresses in flash.

As illustrated in [Memory](#) on page 17, the flash is divided into multiple pages. The same 32-bit word in the flash can only be written n_{WRITE} number of times before a page erase must be performed.

The NVMC is only able to write 0 to bits in the flash that are erased (set to 1). It cannot rewrite a bit back to 1. Only full 32-bit words can be written to flash using the NVMC interface. To write less than 32 bits, write the data as a full 32-bit word and set all the bits that should remain unchanged in the word to 1. Note that the restriction on the number of writes (n_{WRITE}) still applies in this case.

Only word-aligned writes are allowed. Byte or half-word-aligned writes will result in a hard fault.

The time it takes to write a word to flash is specified by t_{WRITE} . The CPU is halted while the NVMC is writing to the flash.

4.3.2 Erasing a page in flash

When erase is enabled, the flash memory can be erased page by page using the [ERASEPAGE](#) on page 22.

After erasing a flash page, all bits in the page are set to 1. The time it takes to erase a page is specified by $t_{\text{ERASEPAGE}}$. The CPU is halted if the CPU executes code from the flash while the NVMC is writing to the flash.

See [Partial erase of a page in flash](#) on page 21 for information on dividing the page erase time into shorter chunks.

4.3.3 Writing to user information configuration registers (UICR)

User information configuration registers (UICR) are written in the same way as flash. After UICR has been written, the new UICR configuration will take effect after a reset.

UICR can only be written n_{WRITE} number of times before an erase must be performed using `ERASEUICR` on page 23 or `ERASEALL` on page 23. The time it takes to write a word to UICR is specified by t_{WRITE} . The CPU is halted while the NVMC is writing to the UICR.

4.3.4 Erasing user information configuration registers (UICR)

When erase is enabled, UICR can be erased using the `ERASEUICR` on page 23.

After erasing UICR all bits in UICR are set to 1. The time it takes to erase UICR is specified by $t_{\text{ERASEPAGE}}$. The CPU is halted if the CPU executes code from the flash while the NVMC performs the erase operation.

4.3.5 Erase all

When erase is enabled, flash and UICR can be erased completely in one operation by using `ERASEALL` on page 23. This operation will not erase the factory information configuration registers (FICR).

The time it takes to perform an `ERASEALL` command is specified by t_{ERASEALL} . The CPU is halted if the CPU executes code from the flash while the NVMC performs the erase operation.

4.3.6 Partial erase of a page in flash

Partial erase is a feature in the NVMC to split a page erase time into shorter chunks, so this can be used to prevent longer CPU stalls in time-critical applications. Partial erase is only applicable to the code area in the flash and does not work with UICR.

When erase is enabled, the partial erase of a flash page can be started by writing to `ERASEPAGEPARTIAL` on page 24. The duration of a partial erase can be configured in `ERASEPAGEPARTIALCFG` on page 24. A flash page is erased when its erase time reaches $t_{\text{ERASEPAGE}}$. Use `ERASEPAGEPARTIAL` N number of times so that $N * \text{ERASEPAGEPARTIALCFG} \geq t_{\text{ERASEPAGE}}$, where $N * \text{ERASEPAGEPARTIALCFG}$ gives the cumulative (total) erase time. Every time the cumulative erase time reaches $t_{\text{ERASEPAGE}}$, it counts as one erase cycle.

After the erase is done, all bits in the page are set to '1'. The CPU is halted if the CPU executes code from the flash while the NVMC performs the partial erase operation.

The bits in the page are undefined if the flash page erase is incomplete, i.e. if a partial erase has started but the total erase time is less than $t_{\text{ERASEPAGE}}$.

4.3.7 Registers

Base address	Peripheral	Instance	Description	Configuration
0x4001E000	NVMC	NVMC	Non-volatile memory controller	

Table 5: Instances

Register	Offset	Description	
<code>READY</code>	0x400	Ready flag	
<code>CONFIG</code>	0x504	Configuration register	
<code>ERASEPAGE</code>	0x508	Register for erasing a page in code area	
<code>ERASEPCR1</code>	0x508	Register for erasing a page in code area. Equivalent to <code>ERASEPAGE</code> .	Deprecated
<code>ERASEALL</code>	0x50C	Register for erasing all non-volatile user memory	
<code>ERASEPCRO</code>	0x510	Register for erasing a page in code area. Equivalent to <code>ERASEPAGE</code> .	Deprecated
<code>ERASEUICR</code>	0x514	Register for erasing user information configuration registers	

Register	Offset	Description
ERASEPAGEPARTIAL	0x518	Register for partial erase of a page in code area
ERASEPAGEPARTIALCFG	0x51C	Register for partial erase configuration

Table 6: Register overview

4.3.7.1 READY

Address offset: 0x400

Ready flag

Bit number	31 30 29 28 27 26 25 24 23 22 21 20 19 18 17 16 15 14 13 12 11 10 9 8 7 6 5 4 3 2 1 0																														
ID	A																														
Reset 0x00000001	0 1																														
ID	Acce	Field	Value ID	Value	Description																										
A	R	READY			NVMC is ready or busy																										
			Busy	0	NVMC is busy (ongoing write or erase operation)																										
			Ready	1	NVMC is ready																										

4.3.7.2 CONFIG

Address offset: 0x504

Configuration register

Bit number	31 30 29 28 27 26 25 24 23 22 21 20 19 18 17 16 15 14 13 12 11 10 9 8 7 6 5 4 3 2 1 0																														
ID	A A																														
Reset 0x00000000	0 0																														
ID	Acce	Field	Value ID	Value	Description																										
A	RW	WEN			Program memory access mode. It is strongly recommended to activate erase and write modes only when they are actively used.																										
			Ren	0	Read only access																										
			Wen	1	Write enabled																										
			Een	2	Erase enabled																										

4.3.7.3 ERASEPAGE

Address offset: 0x508

Register for erasing a page in code area

Bit number	31 30 29 28 27 26 25 24 23 22 21 20 19 18 17 16 15 14 13 12 11 10 9 8 7 6 5 4 3 2 1 0																														
ID	A A																														
Reset 0x00000000	0 0																														
ID	Acce	Field	Value ID	Value	Description																										
A	RW	ERASEPAGE			Register for starting erase of a page in code area.																										
					The value is the address to the page to be erased (addresses of first word in page). Note that the erase must be enabled using CONFIG.WEN before the page can be erased.																										
					Attempts to erase pages that are outside the code area may result in undesirable behavior, e.g. the wrong page may be erased.																										

4.3.7.4 ERASEPCR1 (Deprecated)

Address offset: 0x508

Register for erasing a page in code area. Equivalent to ERASEPAGE.

Bit number	31	30	29	28	27	26	25	24	23	22	21	20	19	18	17	16	15	14	13	12	11	10	9	8	7	6	5	4	3	2	1	0
ID	A	A	A	A	A	A	A	A	A	A	A	A	A	A	A	A	A	A	A	A	A	A	A	A	A	A	A	A	A	A	A	A
Reset 0x00000000	0	0	0	0	0	0	0	0	0	0	0	0	0	0	0	0	0	0	0	0	0	0	0	0	0	0	0	0	0	0	0	
ID	Acce Field	Value ID	Value	Description																												
A	RW	ERASEPCR1		Register for erasing a page in code area. Equivalent to ERASEPAGE.																												

4.3.7.5 ERASEALL

Address offset: 0x50C

Register for erasing all non-volatile user memory

Bit number	31	30	29	28	27	26	25	24	23	22	21	20	19	18	17	16	15	14	13	12	11	10	9	8	7	6	5	4	3	2	1	0
ID																																A
Reset 0x00000000	0	0	0	0	0	0	0	0	0	0	0	0	0	0	0	0	0	0	0	0	0	0	0	0	0	0	0	0	0	0	0	0
ID	Acce Field	Value ID	Value	Description																												
A	RW	ERASEALL		Erase all non-volatile memory including UICR registers. Note that the erase must be enabled using CONFIG.WEN before the non-volatile memory can be erased.																												
		NoOperation	0	No operation																												
		Erase	1	Start erase of chip																												

4.3.7.6 ERASEPCR0 (Deprecated)

Address offset: 0x510

Register for erasing a page in code area. Equivalent to ERASEPAGE.

Bit number	31	30	29	28	27	26	25	24	23	22	21	20	19	18	17	16	15	14	13	12	11	10	9	8	7	6	5	4	3	2	1	0
ID	A	A	A	A	A	A	A	A	A	A	A	A	A	A	A	A	A	A	A	A	A	A	A	A	A	A	A	A	A	A	A	
Reset 0x00000000	0	0	0	0	0	0	0	0	0	0	0	0	0	0	0	0	0	0	0	0	0	0	0	0	0	0	0	0	0	0	0	
ID	Acce Field	Value ID	Value	Description																												
A	RW	ERASEPCR0		Register for starting erase of a page in code area. Equivalent to ERASEPAGE.																												

4.3.7.7 ERASEUICR

Address offset: 0x514

Register for erasing user information configuration registers

Bit number	31 30 29 28 27 26 25 24 23 22 21 20 19 18 17 16 15 14 13 12 11 10 9 8 7 6 5 4 3 2 1 0																														
ID	A																														
Reset	0x00000000																														
Reset	0 0																														
ID	Acce Field	Value ID	Value	Description																											
A	RW	ERASEUICR		Register starting erase of all user information configuration registers. Note that the erase must be enabled using CONFIG.WEN before the UICR can be erased.																											
		NoOperation	0	No operation																											
		Erase	1	Start erase of UICR																											

4.3.7.8 ERASEPAGEPARTIAL

Address offset: 0x518

Register for partial erase of a page in code area

Bit number	31 30 29 28 27 26 25 24 23 22 21 20 19 18 17 16 15 14 13 12 11 10 9 8 7 6 5 4 3 2 1 0																														
ID	A A																														
Reset	0x00000000																														
Reset	0 0																														
ID	Acce Field	Value ID	Value	Description																											
A	RW	ERASEPAGEPARTIAL		Register for starting partial erase of a page in code area																											
				The value is the address to the page to be partially erased (address of the first word in page). Note that the erase must be enabled using CONFIG.WEN before every erase page partial and disabled using CONFIG.WEN after every erase page partial. Attempts to erase pages that are outside the code area may result in undesirable behaviour, e.g. the wrong page may be erased.																											

4.3.7.9 ERASEPAGEPARTIALCFG

Address offset: 0x51C

Register for partial erase configuration

Bit number	31 30 29 28 27 26 25 24 23 22 21 20 19 18 17 16 15 14 13 12 11 10 9 8 7 6 5 4 3 2 1 0																														
ID	A A A A A A A A																														
Reset	0x0000000A																														
Reset	0 1 0 1 0																														
ID	Acce Field	Value ID	Value	Description																											
A	RW	DURATION		Duration of the partial erase in milliseconds																											
				The user must ensure that the total erase time is long enough for a complete erase of the flash page.																											

4.3.8 Electrical specification

4.3.8.1 Flash programming

Symbol	Description	Min.	Typ.	Max.	Units
n_{WRITE}	Number of times a 32-bit word can be written before erase			2	
$n_{\text{ENDURANCE}}$	Erase cycles per page	10000			
t_{WRITE}	Time to write one 32-bit word			41^2	μs
$t_{\text{ERASEPAGE}}$	Time to erase one page			85^2	ms
t_{ERASEALL}	Time to erase all flash			169^2	ms
$t_{\text{ERASEPAGEPARTIAL,acc}}$	Accuracy of the partial page erase duration. Total execution time for one partial page erase is defined as $\text{ERASEPAGEPARTIALCFG} * t_{\text{ERASEPAGEPARTIAL,acc}}$			1.05^2	

4.4 FICR — Factory information configuration registers

Factory information configuration registers (FICR) are pre-programmed in factory and cannot be erased by the user. These registers contain chip-specific information and configuration.

4.4.1 Registers

Base address	Peripheral	Instance	Description	Configuration
0x10000000	FICR	FICR	Factory information configuration	

Table 7: Instances

Register	Offset	Description	
CODEPAGESIZE	0x010	Code memory page size	
CODESIZE	0x014	Code memory size	
DEVICEID[0]	0x060	Device identifier	
DEVICEID[1]	0x064	Device identifier	
ER[0]	0x080	Encryption root, word 0	
ER[1]	0x084	Encryption root, word 1	
ER[2]	0x088	Encryption root, word 2	
ER[3]	0x08C	Encryption root, word 3	
IR[0]	0x090	Identity root, word 0	
IR[1]	0x094	Identity root, word 1	
IR[2]	0x098	Identity root, word 2	
IR[3]	0x09C	Identity root, word 3	
DEVICEADDRTYPE	0x0A0	Device address type	
DEVICEADDR[0]	0x0A4	Device address 0	
DEVICEADDR[1]	0x0A8	Device address 1	
INFO.PART	0x100	Part code	
INFO.VARIANT	0x104	Part variant, hardware version and production configuration	
INFO.PACKAGE	0x108	Package option	
INFO.RAM	0x10C	RAM variant	
INFO.FLASH	0x110	Flash variant	
INFO.UNUSED8[0]	0x114		Reserved

² HFXO is used here

Register	Offset	Description	
INFO.UNUSED8[1]	0x118		Reserved
INFO.UNUSED8[2]	0x11C		Reserved
TEMP.A0	0x404	Slope definition A0	
TEMP.A1	0x408	Slope definition A1	
TEMP.A2	0x40C	Slope definition A2	
TEMP.A3	0x410	Slope definition A3	
TEMP.A4	0x414	Slope definition A4	
TEMP.A5	0x418	Slope definition A5	
TEMP.B0	0x41C	Y-intercept B0	
TEMP.B1	0x420	Y-intercept B1	
TEMP.B2	0x424	Y-intercept B2	
TEMP.B3	0x428	Y-intercept B3	
TEMP.B4	0x42C	Y-intercept B4	
TEMP.B5	0x430	Y-intercept B5	
TEMP.T0	0x434	Segment end T0	
TEMP.T1	0x438	Segment end T1	
TEMP.T2	0x43C	Segment end T2	
TEMP.T3	0x440	Segment end T3	
TEMP.T4	0x444	Segment end T4	

Table 8: Register overview

4.4.1.1 CODEPAGESIZE

Address offset: 0x010

Code memory page size

Bit number	31	30	29	28	27	26	25	24	23	22	21	20	19	18	17	16	15	14	13	12	11	10	9	8	7	6	5	4	3	2	1	0
ID	A	A	A	A	A	A	A	A	A	A	A	A	A	A	A	A	A	A	A	A	A	A	A	A	A	A	A	A	A	A	A	A
Reset 0x00001000	0	0	0	0	0	0	0	0	0	0	0	0	0	0	0	0	0	0	0	0	0	0	0	1	0	0	0	0	0	0	0	0
ID	Acce	Field	Value ID	Value	Description																											
A	R	CODEPAGESIZE			Code memory page size																											

4.4.1.2 CODESIZE

Address offset: 0x014

Code memory size

Bit number	31	30	29	28	27	26	25	24	23	22	21	20	19	18	17	16	15	14	13	12	11	10	9	8	7	6	5	4	3	2	1	0	
ID	A	A	A	A	A	A	A	A	A	A	A	A	A	A	A	A	A	A	A	A	A	A	A	A	A	A	A	A	A	A	A		
Reset 0x00000030	0	0	0	0	0	0	0	0	0	0	0	0	0	0	0	0	0	0	0	0	0	0	0	0	0	0	0	0	1	1	0	0	0
ID	Acce	Field	Value ID	Value	Description																												
A	R	CODESIZE			Code memory size in number of pages																												

Total code space is: CODEPAGESIZE * CODESIZE

4.4.1.3 DEVICEID[n] (n=0..1)

Address offset: 0x060 + (n × 0x4)

Device identifier

Bit number	31	30	29	28	27	26	25	24	23	22	21	20	19	18	17	16	15	14	13	12	11	10	9	8	7	6	5	4	3	2	1	0
ID	A	A	A	A	A	A	A	A	A	A	A	A	A	A	A	A	A	A	A	A	A	A	A	A	A	A	A	A	A	A	A	A
Reset 0xFFFFFFFF	1	1	1	1	1	1	1	1	1	1	1	1	1	1	1	1	1	1	1	1	1	1	1	1	1	1	1	1	1	1	1	
ID	Acce	Field	Value ID	Value	Description																											
A	R	DEVICEID			64 bit unique device identifier																											
					DEVICEID[0] contains the least significant bits of the device identifier. DEVICEID[1] contains the most significant bits of the device identifier.																											

4.4.1.4 ER[n] (n=0..3)

Address offset: 0x080 + (n × 0x4)

Encryption root, word n

Bit number	31	30	29	28	27	26	25	24	23	22	21	20	19	18	17	16	15	14	13	12	11	10	9	8	7	6	5	4	3	2	1	0
ID	A	A	A	A	A	A	A	A	A	A	A	A	A	A	A	A	A	A	A	A	A	A	A	A	A	A	A	A	A	A	A	
Reset 0xFFFFFFFF	1	1	1	1	1	1	1	1	1	1	1	1	1	1	1	1	1	1	1	1	1	1	1	1	1	1	1	1	1	1	1	
ID	Acce	Field	Value ID	Value	Description																											
A	R	ER			Encryption root, word n																											

4.4.1.5 IR[n] (n=0..3)

Address offset: 0x090 + (n × 0x4)

Identity root, word n

Bit number	31	30	29	28	27	26	25	24	23	22	21	20	19	18	17	16	15	14	13	12	11	10	9	8	7	6	5	4	3	2	1	0
ID	A	A	A	A	A	A	A	A	A	A	A	A	A	A	A	A	A	A	A	A	A	A	A	A	A	A	A	A	A	A	A	
Reset 0xFFFFFFFF	1	1	1	1	1	1	1	1	1	1	1	1	1	1	1	1	1	1	1	1	1	1	1	1	1	1	1	1	1	1	1	
ID	Acce	Field	Value ID	Value	Description																											
A	R	IR			Identity root, word n																											

4.4.1.6 DEVICEADDRTYPE

Address offset: 0x0A0

Device address type

Bit number	31	30	29	28	27	26	25	24	23	22	21	20	19	18	17	16	15	14	13	12	11	10	9	8	7	6	5	4	3	2	1	0
ID	A																															
Reset 0xFFFFFFFF	1	1	1	1	1	1	1	1	1	1	1	1	1	1	1	1	1	1	1	1	1	1	1	1	1	1	1	1	1	1	1	1
ID	Acce	Field	Value ID	Value	Description																											
A	R	DEVICEADDRTYPE			Device address type																											
			Public	0	Public address																											
			Random	1	Random address																											

4.4.1.7 DEVICEADDR[n] (n=0..1)

Address offset: 0x0A4 + (n × 0x4)

Device address n

Bit number	31	30	29	28	27	26	25	24	23	22	21	20	19	18	17	16	15	14	13	12	11	10	9	8	7	6	5	4	3	2	1	0
ID	A	A	A	A	A	A	A	A	A	A	A	A	A	A	A	A	A	A	A	A	A	A	A	A	A	A	A	A	A	A	A	A
Reset 0xFFFFFFFF	1	1	1	1	1	1	1	1	1	1	1	1	1	1	1	1	1	1	1	1	1	1	1	1	1	1	1	1	1	1	1	
ID	Acce	Field	Value ID	Value	Description																											
A	R	DEVICEADDR			48 bit device address																											
					DEVICEADDR[0] contains the least significant bits of the device address. DEVICEADDR[1] contains the most significant bits of the device address. Only bits [15:0] of DEVICEADDR[1] are used.																											

4.4.1.8 INFO.PART

Address offset: 0x100

Part code

Bit number	31	30	29	28	27	26	25	24	23	22	21	20	19	18	17	16	15	14	13	12	11	10	9	8	7	6	5	4	3	2	1	0
ID	A	A	A	A	A	A	A	A	A	A	A	A	A	A	A	A	A	A	A	A	A	A	A	A	A	A	A	A	A	A	A	
Reset 0x00052810	0	0	0	0	0	0	0	0	0	0	0	0	0	1	0	1	0	0	1	0	1	0	0	0	0	0	0	0	1	0	0	0
ID	Acce	Field	Value ID	Value	Description																											
A	R	PART			Part code																											
			N52810	0x52810	nRF52810																											
			Unspecified	0xFFFFFFFF	Unspecified																											

4.4.1.9 INFO.VARIANT

Address offset: 0x104

Part variant, hardware version and production configuration

Bit number	31	30	29	28	27	26	25	24	23	22	21	20	19	18	17	16	15	14	13	12	11	10	9	8	7	6	5	4	3	2	1	0
ID	A	A	A	A	A	A	A	A	A	A	A	A	A	A	A	A	A	A	A	A	A	A	A	A	A	A	A	A	A	A	A	
Reset 0xFFFFFFFF	1	1	1	1	1	1	1	1	1	1	1	1	1	1	1	1	1	1	1	1	1	1	1	1	1	1	1	1	1	1	1	
ID	Acce	Field	Value ID	Value	Description																											
A	R	VARIANT			Part variant, hardware version and production configuration, encoded as ASCII																											
			AAAA	0x41414141	AAAA																											
			AAA0	0x41414130	AAA0																											
			AABA	0x41414241	AABA																											
			AABB	0x41414242	AABB																											
			AAB0	0x41414230	AAB0																											
			AACA	0x41414341	AACA																											
			AACB	0x41414342	AACB																											
			AAC0	0x41414330	AAC0																											
			Unspecified	0xFFFFFFFF	Unspecified																											

4.4.1.10 INFO.PACKAGE

Address offset: 0x108

Package option

Bit number	31 30 29 28 27 26 25 24 23 22 21 20 19 18 17 16 15 14 13 12 11 10 9 8 7 6 5 4 3 2 1 0																															
ID	A A																															
Reset 0xFFFFFFFF	1 1																															
ID	Acce Field	Value ID	Value	Description																												
A	R PACKAGE			Package option																												
		QF	0x2000	QFxx - 48-pin QFN																												
		QC	0x2003	QCxx - 32-pin QFN																												
		CA	0x2004	CAxx - WLCSF																												
		Unspecified	0xFFFFFFFF	Unspecified																												

4.4.1.11 INFO.RAM

Address offset: 0x10C

RAM variant

Bit number	31 30 29 28 27 26 25 24 23 22 21 20 19 18 17 16 15 14 13 12 11 10 9 8 7 6 5 4 3 2 1 0																															
ID	A A																															
Reset 0x00000018	0 1 1 0 0 0 0																															
ID	Acce Field	Value ID	Value	Description																												
A	R RAM			RAM variant																												
		K24	0x18	24 kByte RAM																												
		Unspecified	0xFFFFFFFF	Unspecified																												

4.4.1.12 INFO.FLASH

Address offset: 0x110

Flash variant

Bit number	31 30 29 28 27 26 25 24 23 22 21 20 19 18 17 16 15 14 13 12 11 10 9 8 7 6 5 4 3 2 1 0																															
ID	A A																															
Reset 0x000000C0	0 1 1 0 0 0 0 0 0																															
ID	Acce Field	Value ID	Value	Description																												
A	R FLASH			Flash variant																												
		K192	0xC0	192 kByte flash																												
		Unspecified	0xFFFFFFFF	Unspecified																												

4.4.1.13 TEMP.A0

Address offset: 0x404

Slope definition A0

Bit number	31 30 29 28 27 26 25 24 23 22 21 20 19 18 17 16 15 14 13 12 11 10 9 8 7 6 5 4 3 2 1 0																															
ID	A A																															
Reset 0x00000320	0 1 1 0 0 1 0 0 0 0 0 0 0																															
ID	Acce Field	Value ID	Value	Description																												
A	R A			A (slope definition) register																												

4.4.1.14 TEMP.A1

Address offset: 0x408

Slope definition A1

Bit number	31	30	29	28	27	26	25	24	23	22	21	20	19	18	17	16	15	14	13	12	11	10	9	8	7	6	5	4	3	2	1	0																									
ID																								A	A	A	A	A	A	A	A	A	A	A	A	A	A	A	A	A	A	A	A	A	A	A	A	A	A	A	A	A	A				
Reset 0x0000343																								0	0	0	0	0	0	0	0	0	0	0	0	0	0	0	0	0	0	0	0	0	0	0	0	1	1	0	1	0	0	0	0	1	1
ID	Acce	Field	Value ID	Value	Description																																																				
A	R	A			A (slope definition) register																																																				

4.4.1.15 TEMP.A2

Address offset: 0x40C

Slope definition A2

Bit number	31	30	29	28	27	26	25	24	23	22	21	20	19	18	17	16	15	14	13	12	11	10	9	8	7	6	5	4	3	2	1	0																										
ID																								A	A	A	A	A	A	A	A	A	A	A	A	A	A	A	A	A	A	A	A	A	A	A	A	A	A	A	A	A	A					
Reset 0x000035D																								0	0	0	0	0	0	0	0	0	0	0	0	0	0	0	0	0	0	0	0	0	0	0	0	1	1	0	1	0	1	1	1	1	0	1
ID	Acce	Field	Value ID	Value	Description																																																					
A	R	A			A (slope definition) register																																																					

4.4.1.16 TEMP.A3

Address offset: 0x410

Slope definition A3

Bit number	31	30	29	28	27	26	25	24	23	22	21	20	19	18	17	16	15	14	13	12	11	10	9	8	7	6	5	4	3	2	1	0																										
ID																								A	A	A	A	A	A	A	A	A	A	A	A	A	A	A	A	A	A	A	A	A	A	A	A	A	A	A	A	A	A	A				
Reset 0x0000400																								0	0	0	0	0	0	0	0	0	0	0	0	0	0	0	0	0	0	0	0	0	0	0	0	0	0	0	0	0	0	0	0	0	0	0
ID	Acce	Field	Value ID	Value	Description																																																					
A	R	A			A (slope definition) register																																																					

4.4.1.17 TEMP.A4

Address offset: 0x414

Slope definition A4

Bit number	31	30	29	28	27	26	25	24	23	22	21	20	19	18	17	16	15	14	13	12	11	10	9	8	7	6	5	4	3	2	1	0																										
ID																								A	A	A	A	A	A	A	A	A	A	A	A	A	A	A	A	A	A	A	A	A	A	A	A	A	A	A	A	A	A	A	A			
Reset 0x0000452																								0	0	0	0	0	0	0	0	0	0	0	0	0	0	0	0	0	0	0	0	0	0	0	0	1	0	0	0	1	0	1	0	0	1	0
ID	Acce	Field	Value ID	Value	Description																																																					
A	R	A			A (slope definition) register																																																					

4.4.1.18 TEMP.A5

Address offset: 0x418

Slope definition A5

Bit number	31	30	29	28	27	26	25	24	23	22	21	20	19	18	17	16	15	14	13	12	11	10	9	8	7	6	5	4	3	2	1	0																										
ID																								A	A	A	A	A	A	A	A	A	A	A	A	A	A	A	A	A	A	A	A	A	A	A	A	A	A	A	A	A	A	A	A			
Reset 0x000037B																								0	0	0	0	0	0	0	0	0	0	0	0	0	0	0	0	0	0	0	0	0	0	0	0	0	1	1	0	1	1	1	1	0	1	1
ID	Acce	Field	Value ID	Value	Description																																																					
A	R	A			A (slope definition) register																																																					

Bit number	31	30	29	28	27	26	25	24	23	22	21	20	19	18	17	16	15	14	13	12	11	10	9	8	7	6	5	4	3	2	1	0
ID	A A A A A A A A A A A A A A A A A A																															
Reset 0x0000004D	0 1 0 0 1 1 0 1																															
ID	Acce Field	Value ID	Value	Description																												
A	R	B		B (y-intercept)																												

4.4.1.24 TEMP.B5

Address offset: 0x430

Y-intercept B5

Bit number	31	30	29	28	27	26	25	24	23	22	21	20	19	18	17	16	15	14	13	12	11	10	9	8	7	6	5	4	3	2	1	0
ID	A A A A A A A A A A A A A A A A A A																															
Reset 0x00003E10	0 0 0 0 0 0 0 0 0 0 0 0 0 0 0 0 0 0 0 1 1 1 1 1 0 0 0 0 1 0 0 0 0																															
ID	Acce Field	Value ID	Value	Description																												
A	R	B		B (y-intercept)																												

4.4.1.25 TEMP.T0

Address offset: 0x434

Segment end T0

Bit number	31	30	29	28	27	26	25	24	23	22	21	20	19	18	17	16	15	14	13	12	11	10	9	8	7	6	5	4	3	2	1	0
ID	A A A A A A A A A A																															
Reset 0x000000E2	0 1 1 1 0 0 0 1 0																															
ID	Acce Field	Value ID	Value	Description																												
A	R	T		T (segment end) register																												

4.4.1.26 TEMP.T1

Address offset: 0x438

Segment end T1

Bit number	31	30	29	28	27	26	25	24	23	22	21	20	19	18	17	16	15	14	13	12	11	10	9	8	7	6	5	4	3	2	1	0
ID	A A A A A A A A A A																															
Reset 0x00000000	0 0																															
ID	Acce Field	Value ID	Value	Description																												
A	R	T		T (segment end) register																												

4.4.1.27 TEMP.T2

Address offset: 0x43C

Segment end T2

Bit number	31	30	29	28	27	26	25	24	23	22	21	20	19	18	17	16	15	14	13	12	11	10	9	8	7	6	5	4	3	2	1	0
ID	A A A A A A A A A A																															
Reset 0x00000014	0 1 0 1 0 0																															
ID	Acce Field	Value ID	Value	Description																												
A	R	T		T (segment end) register																												

4.4.1.28 TEMP.T3

Address offset: 0x440

Segment end T3

Bit number	31	30	29	28	27	26	25	24	23	22	21	20	19	18	17	16	15	14	13	12	11	10	9	8	7	6	5	4	3	2	1	0																										
ID																											A	A	A	A	A	A	A	A	A	A	A	A	A	A	A	A	A	A	A	A	A	A	A	A	A	A	A	A	A			
Reset 0x00000019																											0	0	0	0	0	0	0	0	0	0	0	0	0	0	0	0	0	0	0	0	0	0	0	0	0	0	0	1	1	0	0	1
ID	Acce	Field	Value ID	Value	Description																																																					
A	R	T			T (segment end) register																																																					

4.4.1.29 TEMP.T4

Address offset: 0x444

Segment end T4

Bit number	31	30	29	28	27	26	25	24	23	22	21	20	19	18	17	16	15	14	13	12	11	10	9	8	7	6	5	4	3	2	1	0																									
ID																											A	A	A	A	A	A	A	A	A	A	A	A	A	A	A	A	A	A	A	A	A	A	A	A	A	A	A	A	A		
Reset 0x00000050																											0	0	0	0	0	0	0	0	0	0	0	0	0	0	0	0	0	0	0	0	0	0	0	0	1	0	1	0	0	0	0
ID	Acce	Field	Value ID	Value	Description																																																				
A	R	T			T (segment end) register																																																				

4.5 UICR — User information configuration registers

The user information configuration registers (UICRs) are non-volatile memory (NVM) registers for configuring user-specific settings.

For information on writing UICR registers, see the [NVMC — Non-volatile memory controller](#) on page 20 and [Memory](#) on page 17 chapters.

4.5.1 Registers

Base address	Peripheral	Instance	Description	Configuration
0x10001000	UICR	UICR	User information configuration	

Table 9: Instances

Register	Offset	Description
UNUSED0	0x000	Reserved
UNUSED1	0x004	Reserved
UNUSED2	0x008	Reserved
UNUSED3	0x010	Reserved
NRFFW[0]	0x014	Reserved for Nordic firmware design
NRFFW[1]	0x018	Reserved for Nordic firmware design
NRFFW[2]	0x01C	Reserved for Nordic firmware design
NRFFW[3]	0x020	Reserved for Nordic firmware design
NRFFW[4]	0x024	Reserved for Nordic firmware design
NRFFW[5]	0x028	Reserved for Nordic firmware design
NRFFW[6]	0x02C	Reserved for Nordic firmware design
NRFFW[7]	0x030	Reserved for Nordic firmware design

Register	Offset	Description
NRFFW[8]	0x034	Reserved for Nordic firmware design
NRFFW[9]	0x038	Reserved for Nordic firmware design
NRFFW[10]	0x03C	Reserved for Nordic firmware design
NRFFW[11]	0x040	Reserved for Nordic firmware design
NRFFW[12]	0x044	Reserved for Nordic firmware design
NRFFW[13]	0x048	Reserved for Nordic firmware design
NRFFW[14]	0x04C	Reserved for Nordic firmware design
NRFW[0]	0x050	Reserved for Nordic hardware design
NRFW[1]	0x054	Reserved for Nordic hardware design
NRFW[2]	0x058	Reserved for Nordic hardware design
NRFW[3]	0x05C	Reserved for Nordic hardware design
NRFW[4]	0x060	Reserved for Nordic hardware design
NRFW[5]	0x064	Reserved for Nordic hardware design
NRFW[6]	0x068	Reserved for Nordic hardware design
NRFW[7]	0x06C	Reserved for Nordic hardware design
NRFW[8]	0x070	Reserved for Nordic hardware design
NRFW[9]	0x074	Reserved for Nordic hardware design
NRFW[10]	0x078	Reserved for Nordic hardware design
NRFW[11]	0x07C	Reserved for Nordic hardware design
CUSTOMER[0]	0x080	Reserved for customer
CUSTOMER[1]	0x084	Reserved for customer
CUSTOMER[2]	0x088	Reserved for customer
CUSTOMER[3]	0x08C	Reserved for customer
CUSTOMER[4]	0x090	Reserved for customer
CUSTOMER[5]	0x094	Reserved for customer
CUSTOMER[6]	0x098	Reserved for customer
CUSTOMER[7]	0x09C	Reserved for customer
CUSTOMER[8]	0x0A0	Reserved for customer
CUSTOMER[9]	0x0A4	Reserved for customer
CUSTOMER[10]	0x0A8	Reserved for customer
CUSTOMER[11]	0x0AC	Reserved for customer
CUSTOMER[12]	0x0B0	Reserved for customer
CUSTOMER[13]	0x0B4	Reserved for customer
CUSTOMER[14]	0x0B8	Reserved for customer
CUSTOMER[15]	0x0BC	Reserved for customer
CUSTOMER[16]	0x0C0	Reserved for customer
CUSTOMER[17]	0x0C4	Reserved for customer
CUSTOMER[18]	0x0C8	Reserved for customer
CUSTOMER[19]	0x0CC	Reserved for customer
CUSTOMER[20]	0x0D0	Reserved for customer
CUSTOMER[21]	0x0D4	Reserved for customer
CUSTOMER[22]	0x0D8	Reserved for customer
CUSTOMER[23]	0x0DC	Reserved for customer
CUSTOMER[24]	0x0E0	Reserved for customer
CUSTOMER[25]	0x0E4	Reserved for customer
CUSTOMER[26]	0x0E8	Reserved for customer
CUSTOMER[27]	0x0EC	Reserved for customer
CUSTOMER[28]	0x0F0	Reserved for customer
CUSTOMER[29]	0x0F4	Reserved for customer
CUSTOMER[30]	0x0F8	Reserved for customer
CUSTOMER[31]	0x0FC	Reserved for customer
PSELRESET[0]	0x200	Mapping of the nRESET function (see POWER chapter for details)
PSELRESET[1]	0x204	Mapping of the nRESET function (see POWER chapter for details)

Register	Offset	Description
APPROTECT	0x208	Access port protection

Table 10: Register overview

4.5.1.1 NRFFW[n] (n=0..14)

Address offset: 0x014 + (n × 0x4)

Reserved for Nordic firmware design

Bit number	31 30 29 28 27 26 25 24 23 22 21 20 19 18 17 16 15 14 13 12 11 10 9 8 7 6 5 4 3 2 1 0																															
ID	A A																															
Reset 0xFFFFFFFF	1 1																															
ID	Acce Field	Value ID	Value	Description																												
A	RW	NRFFW		Reserved for Nordic firmware design																												

4.5.1.2 NRFHW[n] (n=0..11)

Address offset: 0x050 + (n × 0x4)

Reserved for Nordic hardware design

Bit number	31 30 29 28 27 26 25 24 23 22 21 20 19 18 17 16 15 14 13 12 11 10 9 8 7 6 5 4 3 2 1 0																															
ID	A A																															
Reset 0xFFFFFFFF	1 1																															
ID	Acce Field	Value ID	Value	Description																												
A	RW	NRFHW		Reserved for Nordic hardware design																												

4.5.1.3 CUSTOMER[n] (n=0..31)

Address offset: 0x080 + (n × 0x4)

Reserved for customer

Bit number	31 30 29 28 27 26 25 24 23 22 21 20 19 18 17 16 15 14 13 12 11 10 9 8 7 6 5 4 3 2 1 0																															
ID	A A																															
Reset 0xFFFFFFFF	1 1																															
ID	Acce Field	Value ID	Value	Description																												
A	RW	CUSTOMER		Reserved for customer																												

4.5.1.4 PSELRESET[n] (n=0..1)

Address offset: 0x200 + (n × 0x4)

Mapping of the nRESET function (see POWER chapter for details)

All PSELRESET registers have to contain the same value for a pin mapping to be valid. If values are not the same, there will be no nRESET function exposed on a GPIO. As a result, the device will always start independently of the levels present on any of the GPIOs.

Bit number	31	30	29	28	27	26	25	24	23	22	21	20	19	18	17	16	15	14	13	12	11	10	9	8	7	6	5	4	3	2	1	0
ID	C																											A	A	A	A	A
Reset 0xFFFFFFFF	1	1	1	1	1	1	1	1	1	1	1	1	1	1	1	1	1	1	1	1	1	1	1	1	1	1	1	1	1	1	1	
ID	Acce	Field	Value	ID	Value	Description																										
A	RW	PIN	21			GPIO pin number onto which nRESET is exposed																										
C	RW	CONNECT		Disconnected	1	Disconnect																										
				Connected	0	Connect																										

4.5.1.5 APPROTECT

Address offset: 0x208

Access port protection

Bit number	31	30	29	28	27	26	25	24	23	22	21	20	19	18	17	16	15	14	13	12	11	10	9	8	7	6	5	4	3	2	1	0			
ID																												A	A	A	A	A	A	A	A
Reset 0xFFFFFFFF	1	1	1	1	1	1	1	1	1	1	1	1	1	1	1	1	1	1	1	1	1	1	1	1	1	1	1	1	1	1	1				
ID	Acce	Field	Value	ID	Value	Description																													
A	RW	PALL				Enable or disable access port protection.																													
				Disabled	0xFF	Disable																													
				Enabled	0x00	Enable																													

See [Debug](#) on page 39 for more information.

4.6 EasyDMA

EasyDMA is a module implemented by some peripherals to gain direct access to Data RAM.

EasyDMA is an AHB bus master similar to CPU and is connected to the AHB multilayer interconnect for direct access to Data RAM. EasyDMA is not able to access flash.

A peripheral can implement multiple EasyDMA instances to provide dedicated channels. For example, for reading and writing of data between the peripheral and RAM. This concept is illustrated in [EasyDMA example](#) on page 36.

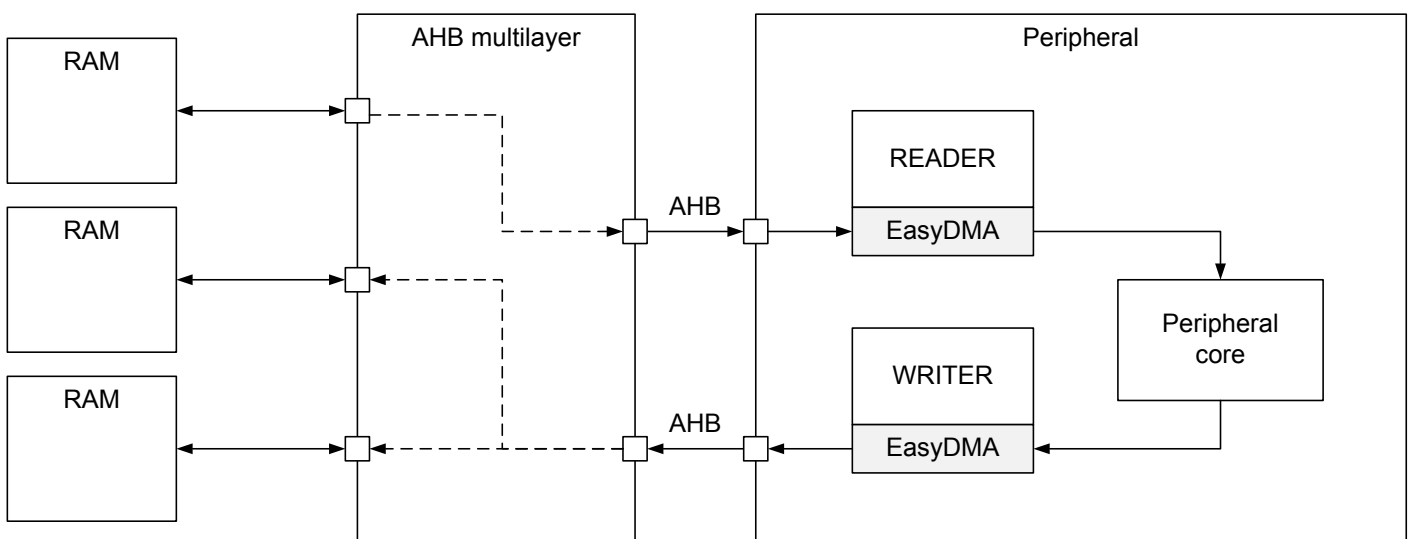

Figure 4: EasyDMA example

An EasyDMA channel is implemented in the following way, but some variations may occur:

```

READERBUFFER_SIZE 5
WRITERBUFFER_SIZE 6

uint8_t readerBuffer[READERBUFFER_SIZE] __at__ 0x20000000;
uint8_t writerBuffer[WRITERBUFFER_SIZE] __at__ 0x20000005;

// Configuring the READER channel
MYPERIPHERAL->READER.MAXCNT = READERBUFFER_SIZE;
MYPERIPHERAL->READER.PTR = &readerBuffer;

// Configure the WRITER channel
MYPERIPHERAL->WRITER.MAXCNT = WRITERBUFFER_SIZE;
MYPERIPHERAL->WRITER.PTR = &writerBuffer;

```

This example shows a peripheral called MYPERIPHERAL that implements two EasyDMA channels - one for reading called READER, and one for writing called WRITER. When the peripheral is started, it is assumed that the peripheral will:

- Read 5 bytes from the readerBuffer located in RAM at address 0x20000000.
- Process the data.
- Write no more than 6 bytes back to the writerBuffer located in RAM at address 0x20000005.

The memory layout of these buffers is illustrated in [EasyDMA memory layout](#) on page 37.

0x20000000	readerBuffer[0]	readerBuffer[1]	readerBuffer[2]	readerBuffer[3]
0x20000004	readerBuffer[4]	writerBuffer[0]	writerBuffer[1]	writerBuffer[2]
0x20000008	writerBuffer[3]	writerBuffer[4]	writerBuffer[5]	

Figure 5: EasyDMA memory layout

The WRITER.MAXCNT register should not be specified larger than the actual size of the buffer (writerBuffer). Otherwise, the channel would overflow the writerBuffer.

Once an EasyDMA transfer is completed, the AMOUNT register can be read by the CPU to see how many bytes were transferred. For example, CPU can read MYPERIPHERAL->WRITER.AMOUNT register to see how many bytes WRITER wrote to RAM.

Note that the PTR register of a READER or WRITER must point to a valid memory region before use. The reset value of a PTR register is not guaranteed to point to valid memory. See [Memory](#) on page 17 for more information about the different memory regions and EasyDMA connectivity.

4.6.1 EasyDMA error handling

Some errors may occur during DMA handling.

If READER.PTR or WRITER.PTR is not pointing to a valid memory region, an EasyDMA transfer may result in a HardFault or RAM corruption. See [Memory](#) on page 17 for more information about the different memory regions.

If several AHB bus masters try to access the same AHB slave at the same time, AHB bus congestion might occur. An EasyDMA channel is an AHB master. Depending on the peripheral, the peripheral may either stall and wait for access to be granted, or lose data.

4.6.2 EasyDMA array list

EasyDMA is able to operate in Array List mode.

The Array List mode is implemented in channels where the LIST register is available.

The array list does not provide a mechanism to explicitly specify where the next item in the list is located. Instead, it assumes that the list is organized as a linear array where items are located one after the other in RAM.

The EasyDMA Array List can be implemented by using the data structure `ArrayList_type` as illustrated in the code example below using a `READER` EasyDMA channel as an example:

```
#define BUFFER_SIZE 4

typedef struct ArrayList
{
    uint8_t buffer[BUFFER_SIZE];
} ArrayList_type;

ArrayList_type ReaderList[3] __at__ 0x20000000;

MYPERIPHERAL->READER.MAXCNT = BUFFER_SIZE;
MYPERIPHERAL->READER.PTR = &ReaderList;
MYPERIPHERAL->READER.LIST = MYPERIPHERAL_READER_LIST_ArrayList;
```

The data structure only includes a buffer with size equal to the size of `READER.MAXCNT` register. EasyDMA uses the `READER.MAXCNT` register to determine when the buffer is full.

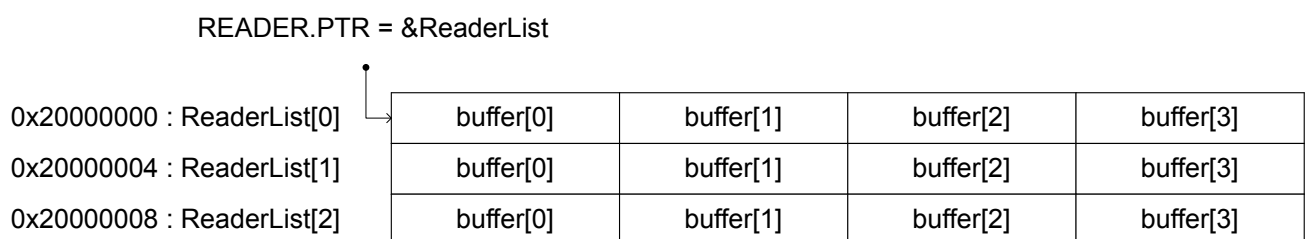

Figure 6: EasyDMA array list

4.7 AHB multilayer

AHB multilayer enables parallel access paths between multiple masters and slaves in a system. Access is resolved using priorities.

Each bus master is connected to the slave devices using an interconnection matrix. The bus masters are assigned priorities. Priorities are used to resolve access when two (or more) bus masters request access to the same slave device. The following applies:

- If two (or more) bus masters request access to the same slave device, the master with the highest priority is granted the access first.
- Bus masters with lower priority are stalled until the higher priority master has completed its transaction.
- If the higher priority master pauses at any point during its transaction, the lower priority master in queue is temporarily granted access to the slave device until the higher priority master resumes its activity.
- Bus masters that have the same priority are mutually exclusive, thus cannot be used concurrently.

Below is a list of bus masters in the system and their priorities.

Bus master name	Description
CPU	
SPIM0/SPIS0	Same priority and mutually exclusive
RADIO	
CCM/ECB/AAR	Same priority and mutually exclusive
SAADC	
UARTE0	
TWIM0/TWIS0	Same priority and mutually exclusive
PDM	
PWM	

Table 11: AHB bus masters (listed in priority order, highest to lowest)

Defined bus masters are the CPU and the peripherals with implemented EasyDMA, and the available slaves are RAM AHB slaves. How the bus masters and slaves are connected using the interconnection matrix is illustrated in [Memory](#) on page 17.

4.8 Debug

Debug system offers a flexible and powerful mechanism for non-intrusive debugging.

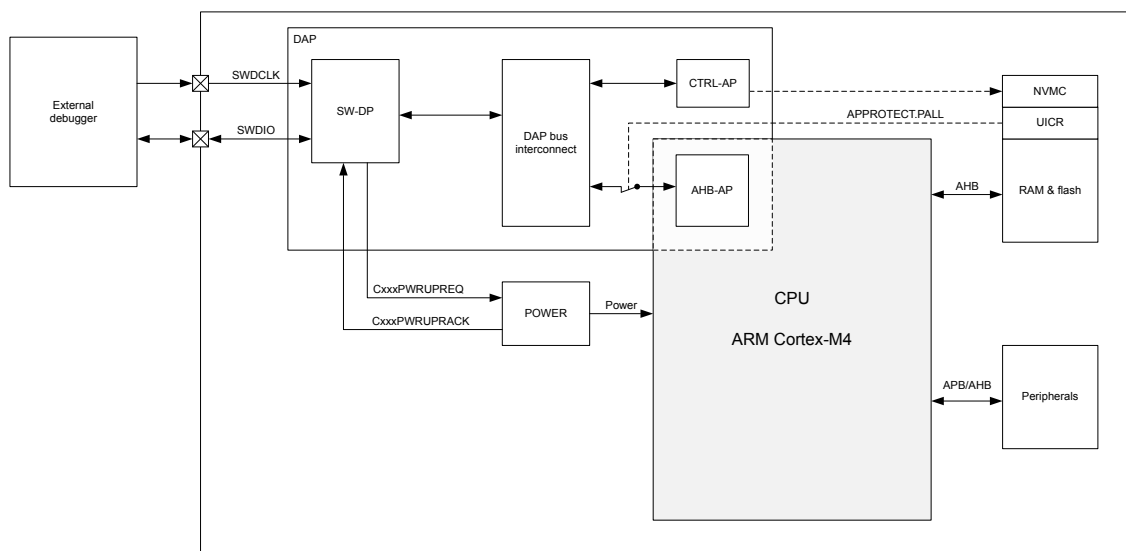

Figure 7: Overview

The main features of the debug system are:

- Two-pin serial wire debug (SWD) interface
- Flash patch and breakpoint (FPB) unit supports:

- Two literal comparators
- Six instruction comparators

4.8.1 DAP - Debug access port

An external debugger can access the device via the DAP.

The debug access port (DAP) implements a standard ARM[®] CoreSight[™] serial wire debug port (SW-DP), which implements the serial wire debug protocol (SWD). SWD is a two-pin serial interface, see SWDCLK and SWDIO in [Overview](#) on page 39.

In addition to the default access port in CPU (AHB-AP), the DAP includes a custom control access port (CTRL-AP). The CTRL-AP is described in more detail in [CTRL-AP - Control access port](#) on page 40.

Note:

- The SWDIO line has an internal pull-up resistor.
- The SWDCLK line has an internal pull-down resistor.

4.8.2 CTRL-AP - Control access port

The control access port (CTRL-AP) is a custom access port that enables control of the device when other access ports in the DAP are disabled by the access port protection.

Access port protection blocks the debugger from read and write access to all CPU registers and memory-mapped addresses. See the UICR register [APPROTECT](#) on page 36 for more information on enabling access port protection.

Control access port has the following features:

- Soft reset, see [Reset](#) on page 53 for more information
- Disabling of access port protection, which is the reason why CTRL-AP allows control of the device even when all other access ports in the DAP are disabled by the access port protection

Access port protection is disabled by issuing an ERASEALL command via CTRL-AP. This command will erase the flash, UICR, and RAM.

4.8.2.1 Registers

Register	Offset	Description
RESET	0x000	Soft reset triggered through CTRL-AP
ERASEALL	0x004	Erase all
ERASEALLSTATUS	0x008	Status register for the ERASEALL operation
APPROTECTSTATUS	0x00C	Status register for access port protection
IDR	0x0FC	CTRL-AP identification register, IDR

Table 12: Register overview

4.8.2.1.1 RESET

Address offset: 0x000

Soft reset triggered through CTRL-AP

Bit number	31	30	29	28	27	26	25	24	23	22	21	20	19	18	17	16	15	14	13	12	11	10	9	8	7	6	5	4	3	2	1	0
ID																																A
Reset 0x00000000	0 0																															
ID	Acce Field	Value ID	Value	Description																												
A	RW	RESET		Soft reset triggered through CTRL-AP. See Reset behavior in POWER chapter for more details.																												
		NoReset	0	Reset is not active																												
		Reset	1	Reset is active. Device is held in reset.																												

4.8.2.1.2 ERASEALL

Address offset: 0x004

Erase all

Bit number	31	30	29	28	27	26	25	24	23	22	21	20	19	18	17	16	15	14	13	12	11	10	9	8	7	6	5	4	3	2	1	0
ID																																A
Reset 0x00000000	0 0																															
ID	Acce Field	Value ID	Value	Description																												
A	W	ERASEALL		Erase all flash and RAM																												
		NoOperation	0	No operation																												
		Erase	1	Erase all flash and RAM																												

4.8.2.1.3 ERASEALLSTATUS

Address offset: 0x008

Status register for the ERASEALL operation

Bit number	31	30	29	28	27	26	25	24	23	22	21	20	19	18	17	16	15	14	13	12	11	10	9	8	7	6	5	4	3	2	1	0
ID																																A
Reset 0x00000000	0 0																															
ID	Acce Field	Value ID	Value	Description																												
A	R	ERASEALLSTATUS		Status register for the ERASEALL operation																												
		Ready	0	ERASEALL is ready																												
		Busy	1	ERASEALL is busy (on-going)																												

4.8.2.1.4 APPROTECTSTATUS

Address offset: 0x00C

Status register for access port protection

Bit number	31	30	29	28	27	26	25	24	23	22	21	20	19	18	17	16	15	14	13	12	11	10	9	8	7	6	5	4	3	2	1	0
ID																																A
Reset 0x00000000	0 0																															
ID	Acce Field	Value ID	Value	Description																												
A	R	APPROTECTSTATUS		Status register for access port protection																												
		Enabled	0	Access port protection enabled																												
		Disabled	1	Access port protection not enabled																												

4.8.2.1.5 IDR

Address offset: 0x0FC

CTRL-AP identification register, IDR

Bit number	31	30	29	28	27	26	25	24	23	22	21	20	19	18	17	16	15	14	13	12	11	10	9	8	7	6	5	4	3	2	1	0	
ID	E	E	E	E	D	D	D	D	C	C	C	C	C	C	C	B	B	B	B							A	A	A	A	A	A	A	A
Reset 0x02880000	0	0	0	0	0	0	0	1	0	1	0	0	0	1	0	0	0	0	0	0	0	0	0	0	0	0	0	0	0	0	0	0	
ID	Acce	Field	Value ID	Value	Description																												
A	R	APID			AP identification																												
B	R	CLASS			Access port (AP) class																												
			NotDefined	0x0	No defined class																												
			MEMAP	0x8	Memory access port																												
C	R	JEP106ID			JEDEC JEP106 identity code																												
D	R	JEP106CONT			JEDEC JEP106 continuation code																												
E	R	REVISION			Revision																												

4.8.2.2 Electrical specification

4.8.2.2.1 Control access port

Symbol	Description	Min.	Typ.	Max.	Units
R_{pull}	Internal SWDIO and SWDCLK pull up/down resistance		13		k Ω
f_{SWDCLK}	SWDCLK frequency	0.125		8	MHz

4.8.3 Debug interface mode

Before an external debugger can access either CPU's access port (AHB-AP) or the control access port (CTRL-AP), the debugger must first request the device to power up via CxxxPWRUPREQ in the SWJ-DP.

If the device is in System OFF when power is requested via CxxxPWRUPREQ, the system will wake up and the DIF flag in [RESETREAS](#) on page 58 will be set. The device is in the debug interface mode as long as the debugger is requesting power via CxxxPWRUPREQ. Once the debugger stops requesting power via CxxxPWRUPREQ, the device is back in normal mode. Some peripherals behave differently in Debug Interface mode compared to normal mode. These differences are described in more detail in the chapters of the peripherals that are affected.

When a debug session is over, the external debugger must make sure to put the device back into normal mode since the overall power consumption is higher in debug interface mode than in normal mode.

For details on how to use the debug capabilities, read the debug documentation of your IDE.

4.8.4 Real-time debug

The nRF52810 supports real-time debugging.

Real-time debugging allows interrupts to execute to completion in real time when breakpoints are set in thread mode or lower priority interrupts. This enables developers to set breakpoints and single-step through the code without the risk of real-time event-driven threads running at higher priority failing. For example, this enables the device to continue to service the high-priority interrupts of an external controller or sensor without failure or loss of state synchronization while the developer steps through code in a low-priority thread.

5 Power and clock management

5.1 Power management unit (PMU)

Power and clock management in nRF52810 is designed to automatically ensure maximum power efficiency.

The core of the power and clock management system is the power management unit (PMU) illustrated in [Power management unit](#) on page 43.

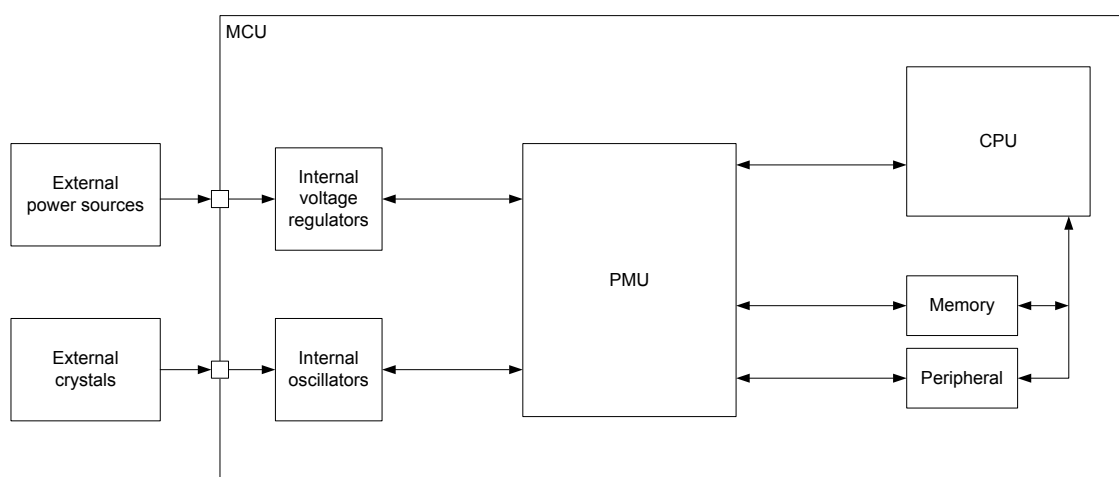

Figure 8: Power management unit

The PMU automatically detects which power and clock resources are required by the different components in the system at any given time. It will then start/stop and choose operation modes in supply regulators and clock sources, without user interaction, to achieve the lowest power consumption possible.

5.2 Current consumption

As the system is being constantly tuned by the [Power management unit \(PMU\)](#) on page 43, estimating the current consumption of an application can be challenging if the designer is not able to perform measurements directly on the hardware. To facilitate the estimation process, a set of current consumption scenarios are provided to show the typical current drawn from the VDD supply.

Each scenario specifies a set of operations and conditions applying to the given scenario. [Current consumption scenarios, common conditions](#) on page 44 shows a set of common conditions used in all scenarios, unless otherwise stated in the description of a given scenario. All scenarios are listed in [Electrical specification](#) on page 44.

Condition	Value
VDD	3 V
Temperature	25°C
CPU	WFI (wait for interrupt)/WFE (wait for event) sleep
Peripherals	All idle
Clock	Not running
Regulator	LDO
RAM	Full 24 kB retention
Compiler ³	GCC v4.9.3 20150529 (arm-none-eabi-gcc). Compiler flags: -O0 -falign-functions=16 -fno-strict-aliasing -mcpu=cortex-m4 -mfloat-abi=soft -msoft-float -mthumb.
32 MHz crystal ⁴	SMD 2520, 32 MHz, 10 pF +/- 10 ppm

Table 13: Current consumption scenarios, common conditions

5.2.1 Electrical specification

5.2.1.1 CPU running

Symbol	Description	Min.	Typ.	Max.	Units
I _{CPU0}	CPU running CoreMark @64 MHz from flash, Clock = HFXO, Regulator = DCDC		2.2		mA
I _{CPU1}	CPU running CoreMark @64 MHz from flash, Clock = HFXO		4.2		mA
I _{CPU2}	CPU running CoreMark @64 MHz from RAM, Clock = HFXO, Regulator = DCDC		2.1		mA
I _{CPU3}	CPU running CoreMark @64 MHz from RAM, Clock = HFXO		4		mA
I _{CPU4}	CPU running CoreMark @64 MHz from flash, Clock = HFINT, Regulator = DCDC		2		mA

³ Applying only when CPU is running

⁴ Applying only when HFXO is running

5.2.1.2 Radio transmitting/receiving

Symbol	Description	Min.	Typ.	Max.	Units
I_{RADIO_TX0}	Radio transmitting @ 4 dBm output power, 1 Mbps Bluetooth low energy mode, Clock = HFXO, Regulator = DCDC		8		mA
I_{RADIO_TX1}	Radio transmitting @ 0 dBm output power, 1 Mbps Bluetooth low energy mode, Clock = HFXO, Regulator = DCDC		5.8		mA
I_{RADIO_TX2}	Radio transmitting @ -40 dBm output power, 1 Mbps Bluetooth low energy mode, Clock = HFXO, Regulator = DCDC		3.4		mA
I_{RADIO_RX0}	Radio receiving @ 1 Mbps Bluetooth low energy mode, Clock = HFXO, Regulator = DCDC		6.1		mA
I_{RADIO_TX3}	Radio transmitting @ 0 dBm output power, 1 Mbps Bluetooth low energy mode, Clock = HFXO		10.5		mA
I_{RADIO_TX4}	Radio transmitting @ -40 dBm output power, 1 Mbps Bluetooth low energy mode, Clock = HFXO		5.1		mA
I_{RADIO_RX1}	Radio receiving @ 1 Mbps Bluetooth low energy mode, Clock = HFXO		10.8		mA

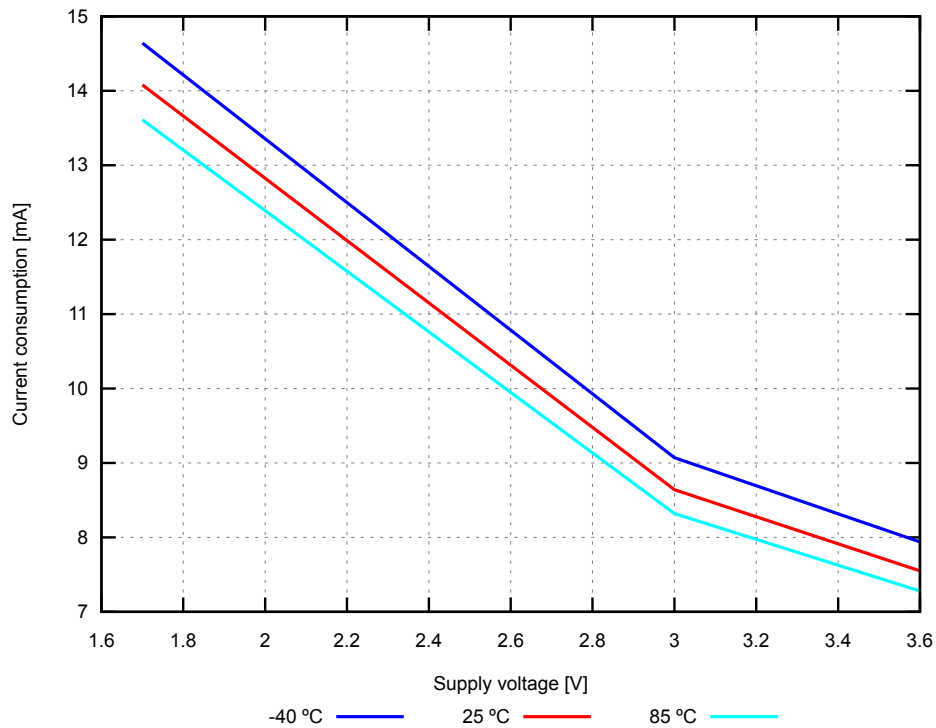

Figure 9: Radio transmitting @ 4 dBm output power, 1 Mbps Bluetooth low energy mode, Clock = HFXO, Regulator = DCDC (typical values)

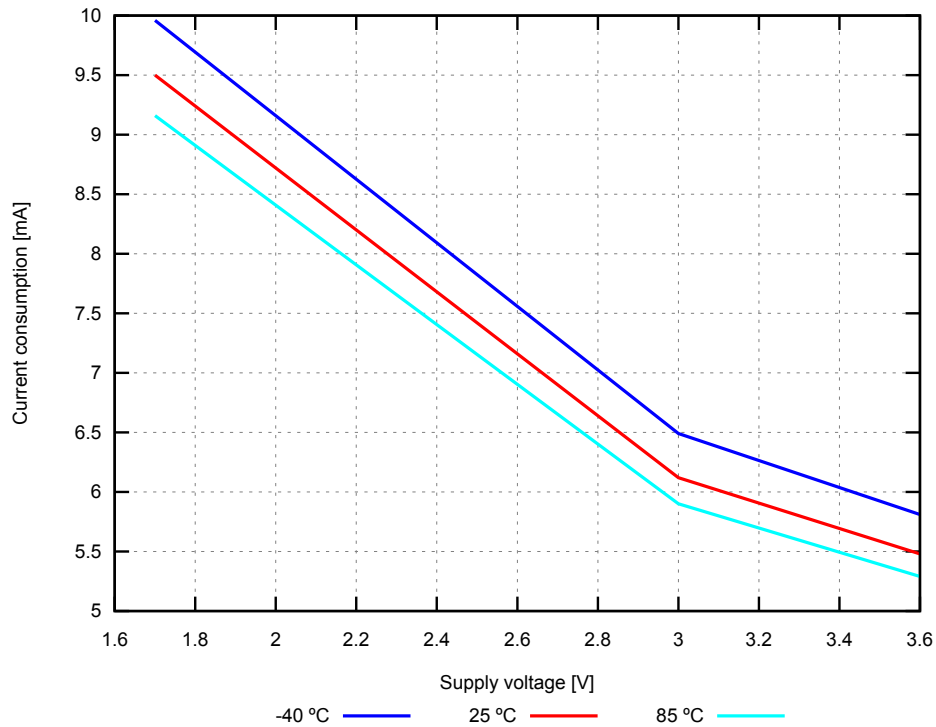

Figure 10: Radio transmitting @ 0 dBm output power, 1 Mbps Bluetooth low energy mode, Clock = HFXO, Regulator = DCDC (typical values)

5.2.1.3 Sleep

Symbol	Description	Min.	Typ.	Max.	Units
I _{ON_RAMOFF_EVENT}	System ON, No RAM retention, Wake on any event		0.6		μA
I _{ON_RAMON_EVENT}	System ON, Full 24 kB RAM retention, Wake on any event		0.8		μA
I _{ON_RAMON_POF}	System ON, Full 24 kB RAM retention, Wake on any event, Power fail comparator enabled		0.8		μA
I _{ON_RAMON_GPIOTE}	System ON, Full 24 kB RAM retention, Wake on GPIOTE input (Event mode)		3.3		μA
I _{ON_RAMON_GPIOTEPORT}	System ON, Full 24 kB RAM retention, Wake on GPIOTE PORT event		0.8		μA
I _{ON_RAMON_RTC}	System ON, Full 24 kB RAM retention, Wake on RTC (running from LFRC clock)		1.5		μA
I _{ON_RAMOFF_RTC}	System ON, No RAM retention, Wake on RTC (running from LFRC clock)		1.4		μA
I _{ON_RAMON_RTC_LFXO}	System ON, Full 24 kB RAM retention, Wake on RTC (running from LFXO clock)		1.1		μA
I _{ON_RAMOFF_RTC_LFXO}	System ON, No RAM retention, Wake on RTC (running from LFXO clock)		1.0		μA
I _{OFF_RAMOFF_RESET}	System OFF, No RAM retention, Wake on reset		0.3		μA
I _{OFF_RAMON_RESET}	System OFF, Full 24 kB RAM retention, Wake on reset		0.5		μA

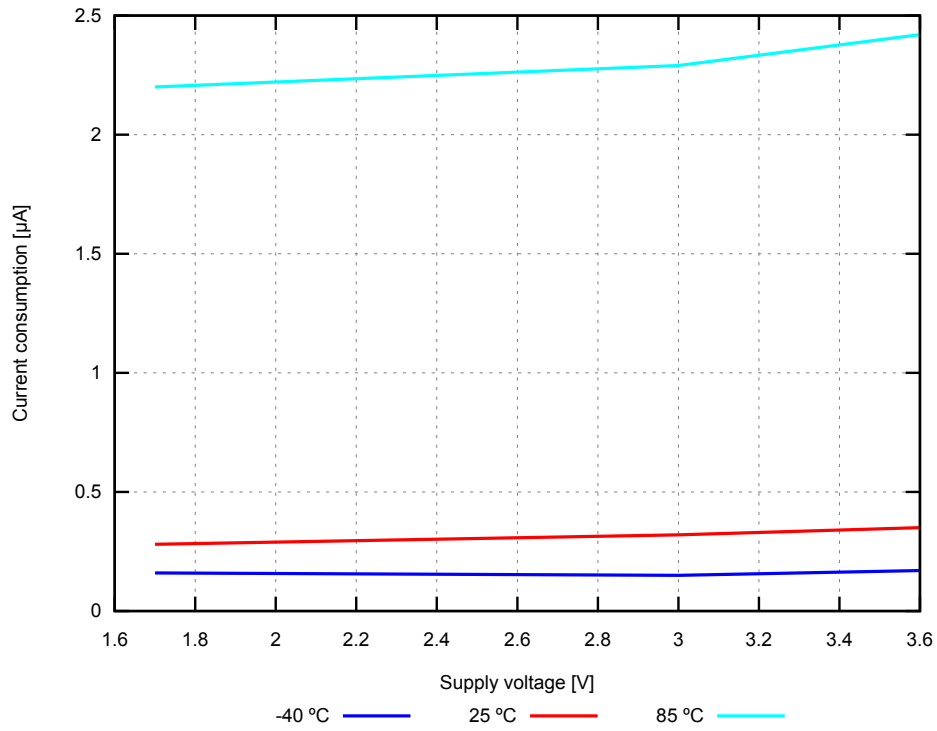

Figure 11: System OFF, No RAM retention, Wake on reset (typical values)

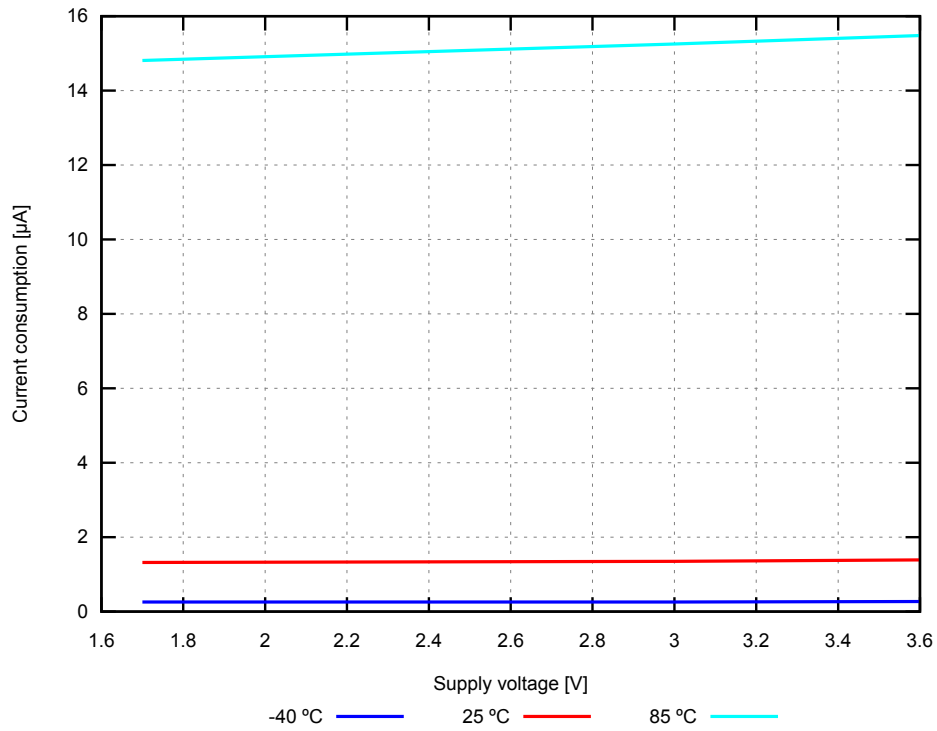

Figure 12: System ON, Full 24 kB RAM retention, Wake on any event (typical values)

5.2.1.4 Compounded

Symbol	Description	Min.	Typ.	Max.	Units
I _{S0}	CPU running CoreMark from flash, Radio transmitting @ 0 dBm output power, 1 Mbps Bluetooth low energy mode, Clock = HFXO, Regulator = DCDC		7.4		mA
I _{S1}	CPU running CoreMark from flash, Radio receiving @ 1 Mbps Bluetooth low energy mode, Clock = HFXO, Regulator = DCDC		7.6		mA
I _{S2}	CPU running CoreMark from flash, Radio transmitting @ 0 dBm output power, 1 Mbps Bluetooth low energy mode, Clock = HFXO		13.8		mA
I _{S3}	CPU running CoreMark from flash, Radio receiving @ 1 Mbps Bluetooth low energy mode, Clock = HFXO		14.2		mA

5.2.1.5 TIMER running

Symbol	Description	Min.	Typ.	Max.	Units
I _{TIMER0}	One TIMER instance running @ 1 MHz, Clock = HFINT		432		μA
I _{TIMER1}	Two TIMER instances running @ 1 MHz, Clock = HFINT		432		μA
I _{TIMER2}	One TIMER instance running @ 1 MHz, Clock = HFXO		730		μA
I _{TIMER3}	One TIMER instance running @ 16 MHz, Clock = HFINT		495		μA
I _{TIMER4}	One TIMER instance running @ 16 MHz, Clock = HFXO		792		μA

5.2.1.6 RNG active

Symbol	Description	Min.	Typ.	Max.	Units
I _{RNG0}	RNG running		539		μA

5.2.1.7 TEMP active

Symbol	Description	Min.	Typ.	Max.	Units
I _{TEMP0}	TEMP started		998		μA

5.2.1.8 SAADC active

Symbol	Description	Min.	Typ.	Max.	Units
I _{SAADC,RUN}	SAADC sampling @ 16 ksps, Acquisition time = 20 μs, Clock = HFXO, Regulator = DCDC		1.1		mA

5.2.1.9 COMP active

Symbol	Description	Min.	Typ.	Max.	Units
I _{COMP,LP}	COMP enabled, low power mode		17.2		μA
I _{COMP,NORM}	COMP enabled, normal mode		21		μA
I _{COMP,HS}	COMP enabled, high-speed mode		28.7		μA

5.2.1.10 WDT active

Symbol	Description	Min.	Typ.	Max.	Units
I _{WDT,STARTED}	WDT started		1.3		μA

5.3 POWER — Power supply

This device has the following power supply features:

- On-chip LDO and DC/DC regulators
- Global System ON/OFF modes with individual RAM section power control
- Analog or digital pin wakeup from System OFF
- Supervisor HW to manage power on reset, brownout, and power fail
- Auto-controlled refresh modes for LDO and DC/DC regulators to maximize efficiency
- Automatic switching between LDO and DC/DC regulator based on load to maximize efficiency

Note: Two additional external passive components are required to use the DC/DC regulator.

5.3.1 Regulators

The following internal power regulator alternatives are supported:

- Internal LDO regulator
- Internal DC/DC regulator

The LDO is the default regulator.

The DC/DC regulator can be used as an alternative to the LDO regulator and is enabled through the [DCDCEN](#) on page 60 register. Using the DC/DC regulator will reduce current consumption compared to when using the LDO regulator, but the DC/DC regulator requires an external LC filter to be connected, as shown in [DC/DC regulator setup](#) on page 50.

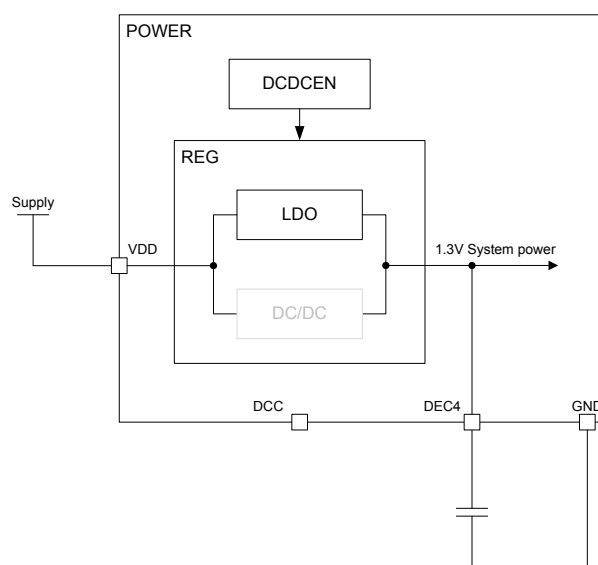

Figure 13: LDO regulator setup

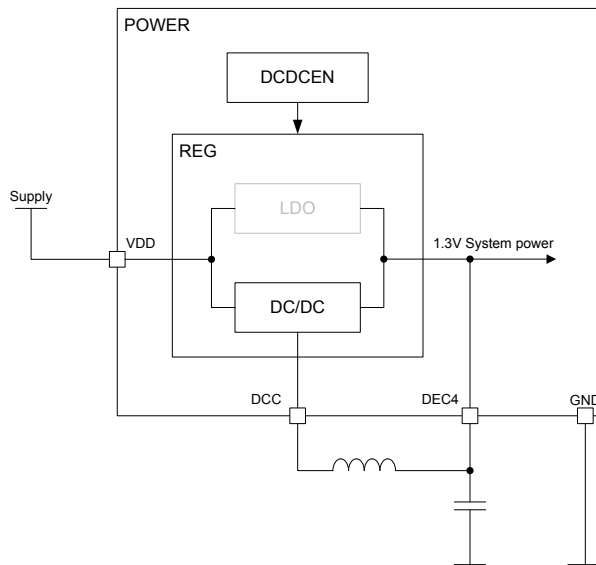

Figure 14: DC/DC regulator setup

5.3.2 System OFF mode

System OFF is the deepest power saving mode the system can enter. In this mode, the system's core functionality is powered down and all ongoing tasks are terminated.

The device can be put into System OFF mode using the register [SYSTEMOFF](#) on page 58. When in System OFF mode, the device can be woken up through one of the following signals:

1. The DETECT signal, optionally generated by the GPIO peripheral
2. A reset

When the system wakes up from System OFF mode, it gets reset. For more details, see [Reset behavior](#) on page 54.

One or more RAM sections can be retained in System OFF mode, depending on the settings in the RAM[n].POWER registers.

RAM[n].POWER are retained registers, see [Reset behavior](#). Note that these registers are usually overwritten by the startup code provided with the nRF application examples.

Before entering System OFF mode, the user must make sure that all on-going EasyDMA transactions have been completed. This is usually accomplished by making sure that the EasyDMA enabled peripheral is not active when entering System OFF.

5.3.2.1 Emulated System OFF mode

If the device is in debug interface mode, System OFF will be emulated to secure that all required resources needed for debugging are available during System OFF.

See [Debug](#) on page 39 for more information. Required resources needed for debugging include the following key components: [Debug](#) on page 39, [CLOCK — Clock control](#) on page 62, [POWER — Power supply](#) on page 49, [NVMC — Non-volatile memory controller](#) on page 20, CPU, Flash, and RAM. Since the CPU is kept on in an emulated System OFF mode, it is recommended to add an infinite loop directly after entering System OFF, to prevent the CPU from executing code that normally should not be executed.

5.3.3 System ON mode

System ON is the default state after power-on reset. In System ON, all functional blocks such as the CPU or peripherals can be in IDLE or RUN mode, depending on the configuration set by the software and the state of the application executing.

Register [RESETREAS](#) on page 58 provides information about the source causing the wakeup or reset.

The system can switch the appropriate internal power sources on and off, depending on how much power is needed at any given time. The power requirement of a peripheral is directly related to its activity level, and the activity level of a peripheral is usually raised and lowered when specific tasks are triggered or events are generated.

5.3.3.1 Sub power modes

In System ON mode, when both the CPU and all the peripherals are in IDLE mode, the system can reside in one of the two sub power modes.

The sub power modes are:

- Constant Latency
- Low-power

In Constant Latency mode, the CPU wakeup latency and the PPI task response are constant and kept at a minimum. This is secured by forcing a set of basic resources to be turned on while in sleep. Having a constant and predictable latency is at the cost of having increased power consumption. The Constant Latency mode is selected by triggering the CONSTLAT task.

In Low-power mode, the automatic power management system described in [System ON mode](#) on page 51 ensures that the most efficient supply option is chosen to save most power. Having the lowest power possible is at the cost of having a varying CPU wakeup latency and PPI task response. The Low-power mode is selected by triggering the LOWPWR task.

When the system enters System ON mode, it is by default in Low-power sub power mode.

5.3.4 Power supply supervisor

The power supply supervisor initializes the system at power-on and provides an early warning of impending power failure.

In addition, the power supply supervisor puts the system in a reset state if the supply voltage is too low for safe operation (brownout). The power supply supervisor is illustrated in [Power supply supervisor](#) on page 52.

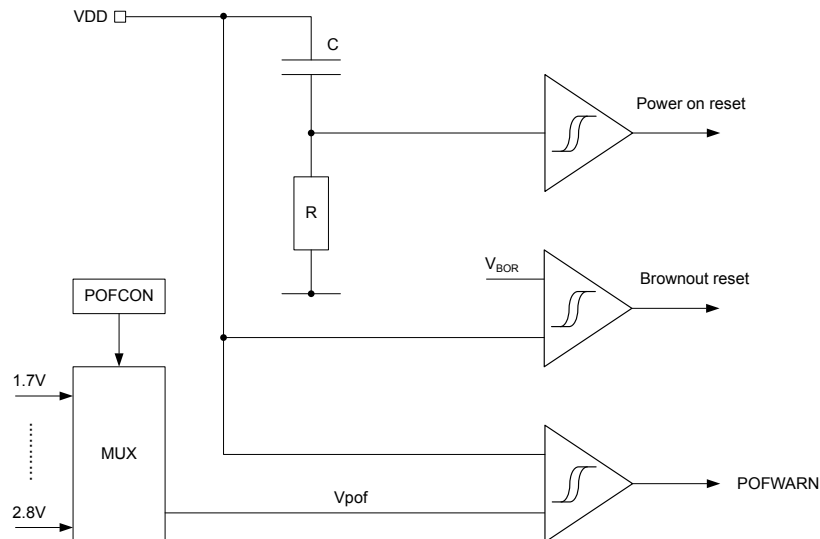

Figure 15: Power supply supervisor

5.3.4.1 Power-fail comparator

The power-fail comparator (POF) can provide the CPU with an early warning of impending power failure. It will not reset the system, but give the CPU time to prepare for an orderly power-down.

The comparator features a hysteresis of V_{HYST} , as illustrated in [Power-fail comparator \(BOR = Brownout reset\)](#) on page 52. The threshold V_{POF} is set in register [POFCON](#) on page 59. If the POF is enabled and the supply voltage falls below V_{POF} , the POFWARN event will be generated. This event will also be generated if the supply voltage is already below V_{POF} at the time the POF is enabled, or if V_{POF} is re-configured to a level above the supply voltage.

If power-fail warning is enabled and the supply voltage is below V_{POF} the power-fail comparator will prevent the NVMC from performing write operations to the NVM. See [NVMC — Non-volatile memory controller](#) on page 20 for more information about the NVMC.

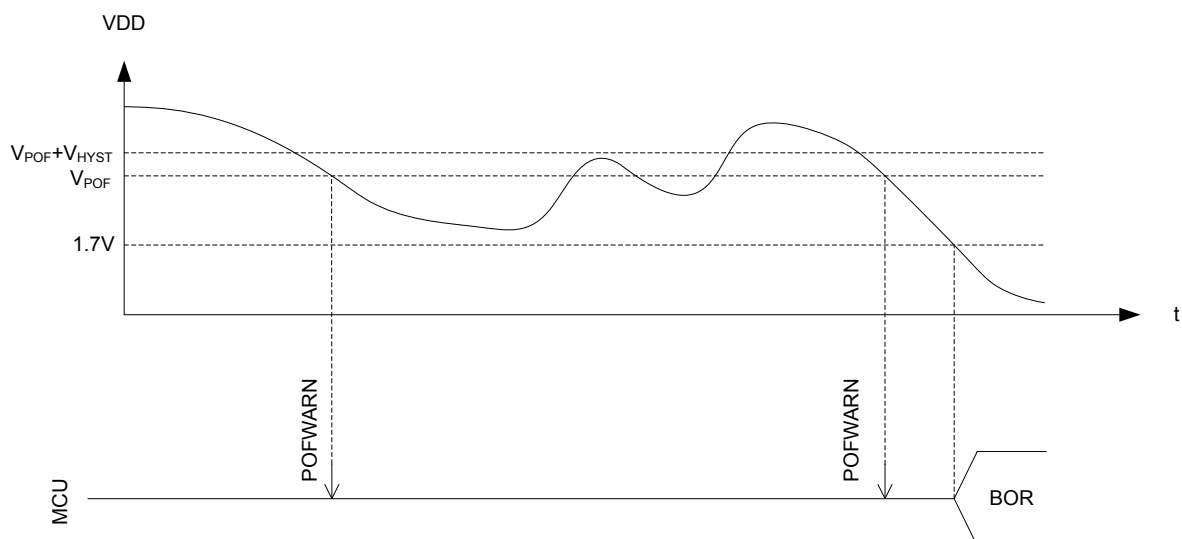

Figure 16: Power-fail comparator (BOR = Brownout reset)

To save power, the power-fail comparator is not active in System OFF or in System ON when HFCLK is not running.

5.3.5 RAM power control

The RAM power control registers are used for configuring the following:

- The RAM sections to be retained during System OFF
- The RAM sections to be retained and accessible during System ON

In System OFF, retention of a RAM section is configured in the RETENTION field of the corresponding RAM[n] register.

In System ON, retention and accessibility for a RAM section is configured in the RETENTION and POWER fields of the corresponding RAM[n] register.

The following table summarizes the behavior of these registers.

Configuration	RAM section status			
	RAM[n].POWER.POWER	RAM[n].POWER.RETENTION	Accessible	Retained
System on/off				
Off	x	Off	No	No
Off	x	On	No	Yes
On	Off	Off	No	No
On	Off ¹	On	No	Yes
On	On	x	Yes	Yes

Table 14: RAM section configuration. x = don't care.

The advantage of not retaining RAM contents is that the overall current consumption is reduced.

See chapter [Memory](#) on page 17 for more information on RAM sections.

5.3.6 Reset

There are multiple sources that may trigger a reset.

After a reset has occurred, register [RESETREAS](#) can be read to determine which source generated the reset.

5.3.6.1 Power-on reset

The power-on reset generator initializes the system at power-on.

The system is held in reset state until the supply has reached the minimum operating voltage and the internal voltage regulators have started.

A step increase in supply voltage of 300 mV or more, with rise time of 300 ms or less, within the valid supply range, may result in a system reset.

5.3.6.2 Pin reset

A pin reset is generated when the physical reset pin on the device is asserted.

Pin reset is configured via the PSELRESET[0] and PSELRESET[1] registers.

Note: Pin reset is not available on all pins.

5.3.6.3 Wakeup from System OFF mode reset

The device is reset when it wakes up from System OFF mode.

¹ Not useful setting. RAM section power off gives negligible reduction in current consumption when retention is on.

The debug access port (DAP) is not reset following a wake up from System OFF mode if the device is in Debug Interface mode. See chapter [Debug](#) on page 39 for more information.

5.3.6.4 Soft reset

A soft reset is generated when the SYSRESETREQ bit of the Application Interrupt and Reset Control Register (AIRCR register) in the ARM® core is set.

Refer to [ARM documentation](#) for more details.

A soft reset can also be generated via the [RESET](#) on page 40 register in the CTRL-AP.

5.3.6.5 Watchdog reset

A Watchdog reset is generated when the watchdog times out.

See chapter [WDT — Watchdog timer](#) on page 381 for more information.

5.3.6.6 Brown-out reset

The brown-out reset generator puts the system in reset state if the supply voltage drops below the brownout reset (BOR) threshold.

Refer to section [Power fail comparator](#) on page 62 for more information.

5.3.7 Retained registers

A retained register is a register that will retain its value in System OFF mode and through a reset, depending on reset source. See individual peripheral chapters for information of which registers are retained for the various peripherals.

5.3.8 Reset behavior

Reset source	Reset target								
	CPU	Peripherals	GPIO	Debug ^a	SWJ-DP	RAM	WDT	Retained registers	RESETREAS
CPU lockup ⁵	x	x	x						
Soft reset	x	x	x						
Wakeup from System OFF mode reset	x	x		x ⁶		x ⁷			
Watchdog reset ⁸	x	x	x	x		x	x	x	
Pin reset	x	x	x	x		x	x	x	
Brownout reset	x	x	x	x	x	x	x	x	x
Power on reset	x	x	x	x	x	x	x	x	x

Note: The RAM is never reset, but depending on reset source, RAM content may be corrupted.

^a All debug components excluding SWJ-DP. See [Debug](#) on page 39 chapter for more information about the different debug components in the system.

⁵ Reset from CPU lockup is disabled if the device is in debug interface mode. CPU lockup is not possible in System OFF.

⁶ The Debug components will not be reset if the device is in debug interface mode.

⁷ RAM is not reset on wakeup from OFF mode, but depending on settings in the RAM register parts, or the whole RAM, may not be retained after the device has entered System OFF mode.

⁸ Watchdog reset is not available in System OFF.

5.3.9 Registers

Base address	Peripheral	Instance	Description	Configuration
0x40000000	POWER	POWER	Power control	For 24 kB RAM variant, only RAM[0].x to RAM[2].x registers are in use.

Table 15: Instances

Register	Offset	Description
TASKS_CONSTLAT	0x078	Enable Constant Latency mode
TASKS_LOWPWR	0x07C	Enable Low-power mode (variable latency)
EVENTS_POFWARN	0x108	Power failure warning
EVENTS_SLEEPENTER	0x114	CPU entered WFI/WFE sleep
EVENTS_SLEEPEXIT	0x118	CPU exited WFI/WFE sleep
INTENSET	0x304	Enable interrupt
INTENCLR	0x308	Disable interrupt
RESETREAS	0x400	Reset reason
SYSTEMOFF	0x500	System OFF register
POFCON	0x510	Power failure comparator configuration
GPREGRET	0x51C	General purpose retention register
GPREGRET2	0x520	General purpose retention register
DCDCEN	0x578	DC/DC enable register
RAM[0].POWER	0x900	RAM0 power control register. The RAM size will vary depending on product variant, and the RAM0 register will only be present if the corresponding RAM AHB slave is present on the device.
RAM[0].POWERSET	0x904	RAM0 power control set register
RAM[0].POWERCLR	0x908	RAM0 power control clear register
RAM[1].POWER	0x910	RAM1 power control register. The RAM size will vary depending on product variant, and the RAM1 register will only be present if the corresponding RAM AHB slave is present on the device.
RAM[1].POWERSET	0x914	RAM1 power control set register
RAM[1].POWERCLR	0x918	RAM1 power control clear register
RAM[2].POWER	0x920	RAM2 power control register. The RAM size will vary depending on product variant, and the RAM2 register will only be present if the corresponding RAM AHB slave is present on the device.
RAM[2].POWERSET	0x924	RAM2 power control set register
RAM[2].POWERCLR	0x928	RAM2 power control clear register
RAM[3].POWER	0x930	RAM3 power control register. The RAM size will vary depending on product variant, and the RAM3 register will only be present if the corresponding RAM AHB slave is present on the device.
RAM[3].POWERSET	0x934	RAM3 power control set register
RAM[3].POWERCLR	0x938	RAM3 power control clear register
RAM[4].POWER	0x940	RAM4 power control register. The RAM size will vary depending on product variant, and the RAM4 register will only be present if the corresponding RAM AHB slave is present on the device.
RAM[4].POWERSET	0x944	RAM4 power control set register
RAM[4].POWERCLR	0x948	RAM4 power control clear register
RAM[5].POWER	0x950	RAM5 power control register. The RAM size will vary depending on product variant, and the RAM5 register will only be present if the corresponding RAM AHB slave is present on the device.
RAM[5].POWERSET	0x954	RAM5 power control set register
RAM[5].POWERCLR	0x958	RAM5 power control clear register

Register	Offset	Description
RAM[6].POWER	0x960	RAM6 power control register. The RAM size will vary depending on product variant, and the RAM6 register will only be present if the corresponding RAM AHB slave is present on the device.
RAM[6].POWERSET	0x964	RAM6 power control set register
RAM[6].POWERCLR	0x968	RAM6 power control clear register
RAM[7].POWER	0x970	RAM7 power control register. The RAM size will vary depending on product variant, and the RAM7 register will only be present if the corresponding RAM AHB slave is present on the device.
RAM[7].POWERSET	0x974	RAM7 power control set register
RAM[7].POWERCLR	0x978	RAM7 power control clear register

Table 16: Register overview

5.3.9.1 TASKS_CONSTLAT

Address offset: 0x078

Enable Constant Latency mode

Bit number	31 30 29 28 27 26 25 24 23 22 21 20 19 18 17 16 15 14 13 12 11 10 9 8 7 6 5 4 3 2 1 0																															
ID																																A
Reset 0x00000000	0 0																															
ID	Acce	Field	Value ID	Value	Description																											
A	W	TASKS_CONSTLAT			Enable Constant Latency mode																											
			Trigger	1	Trigger task																											

5.3.9.2 TASKS_LOWPWR

Address offset: 0x07C

Enable Low-power mode (variable latency)

Bit number	31 30 29 28 27 26 25 24 23 22 21 20 19 18 17 16 15 14 13 12 11 10 9 8 7 6 5 4 3 2 1 0																															
ID																																A
Reset 0x00000000	0 0																															
ID	Acce	Field	Value ID	Value	Description																											
A	W	TASKS_LOWPWR			Enable Low-power mode (variable latency)																											
			Trigger	1	Trigger task																											

5.3.9.3 EVENTS_POFWARN

Address offset: 0x108

Power failure warning

Bit number	31 30 29 28 27 26 25 24 23 22 21 20 19 18 17 16 15 14 13 12 11 10 9 8 7 6 5 4 3 2 1 0																															
ID																																A
Reset 0x00000000	0 0																															
ID	Acce	Field	Value ID	Value	Description																											
A	RW	EVENTS_POFWARN			Power failure warning																											
			NotGenerated	0	Event not generated																											
			Generated	1	Event generated																											

5.3.9.4 EVENTS_SLEEPENTER

Address offset: 0x114

CPU entered WFI/WFE sleep

Bit number	31 30 29 28 27 26 25 24 23 22 21 20 19 18 17 16 15 14 13 12 11 10 9 8 7 6 5 4 3 2 1 0																														
ID	A																														
Reset 0x00000000	0 0																														
ID	Acce Field	Value ID	Value	Description																											
A	RW	EVENTS_SLEEPENTER		CPU entered WFI/WFE sleep																											
			NotGenerated	0	Event not generated																										
			Generated	1	Event generated																										

5.3.9.5 EVENTS_SLEEPEXIT

Address offset: 0x118

CPU exited WFI/WFE sleep

Bit number	31 30 29 28 27 26 25 24 23 22 21 20 19 18 17 16 15 14 13 12 11 10 9 8 7 6 5 4 3 2 1 0																														
ID	A																														
Reset 0x00000000	0 0																														
ID	Acce Field	Value ID	Value	Description																											
A	RW	EVENTS_SLEEPEXIT		CPU exited WFI/WFE sleep																											
			NotGenerated	0	Event not generated																										
			Generated	1	Event generated																										

5.3.9.6 INTENSET

Address offset: 0x304

Enable interrupt

Bit number	31 30 29 28 27 26 25 24 23 22 21 20 19 18 17 16 15 14 13 12 11 10 9 8 7 6 5 4 3 2 1 0																														
ID																													C B A		
Reset 0x00000000	0 0																														
ID	Acce Field	Value ID	Value	Description																											
A	RW	POFWARN		Write '1' to enable interrupt for event POFWARN																											
			Set	1	Enable																										
			Disabled	0	Read: Disabled																										
			Enabled	1	Read: Enabled																										
B	RW	SLEEPENTER		Write '1' to enable interrupt for event SLEEPENTER																											
			Set	1	Enable																										
			Disabled	0	Read: Disabled																										
			Enabled	1	Read: Enabled																										
C	RW	SLEEPEXIT		Write '1' to enable interrupt for event SLEEPEXIT																											
			Set	1	Enable																										
			Disabled	0	Read: Disabled																										
			Enabled	1	Read: Enabled																										

5.3.9.7 INTENCLR

Address offset: 0x308

Disable interrupt

Bit number		31 30 29 28 27 26 25 24 23 22 21 20 19 18 17 16 15 14 13 12 11 10 9 8 7 6 5 4 3 2 1 0																												
ID																												C	B	A
Reset 0x00000000		0 0																												
ID	Acce Field	Value ID	Value	Description																										
A	RW POFWARN			Write '1' to disable interrupt for event POFWARN																										
		Clear	1	Disable																										
		Disabled	0	Read: Disabled																										
		Enabled	1	Read: Enabled																										
B	RW SLEEPENTER			Write '1' to disable interrupt for event SLEEPENTER																										
		Clear	1	Disable																										
		Disabled	0	Read: Disabled																										
		Enabled	1	Read: Enabled																										
C	RW SLEEPEXIT			Write '1' to disable interrupt for event SLEEPEXIT																										
		Clear	1	Disable																										
		Disabled	0	Read: Disabled																										
		Enabled	1	Read: Enabled																										

5.3.9.8 RESETRAS

Address offset: 0x400

Reset reason

Unless cleared, the RESETRAS register will be cumulative. A field is cleared by writing '1' to it. If none of the reset sources are flagged, this indicates that the chip was reset from the on-chip reset generator, which will indicate a power-on-reset or a brownout reset.

Bit number		31 30 29 28 27 26 25 24 23 22 21 20 19 18 17 16 15 14 13 12 11 10 9 8 7 6 5 4 3 2 1 0																															
ID																												F	E	D	C	B	A
Reset 0x00000000		0 0																															
ID	Acce Field	Value ID	Value	Description																													
A	RW RESETPIN			Reset from pin-reset detected																													
		NotDetected	0	Not detected																													
		Detected	1	Detected																													
B	RW DOG			Reset from watchdog detected																													
		NotDetected	0	Not detected																													
		Detected	1	Detected																													
C	RW SREQ			Reset from soft reset detected																													
		NotDetected	0	Not detected																													
		Detected	1	Detected																													
D	RW LOCKUP			Reset from CPU lock-up detected																													
		NotDetected	0	Not detected																													
		Detected	1	Detected																													
E	RW OFF			Reset due to wake up from System OFF mode when wakeup is triggered from DETECT signal from GPIO																													
		NotDetected	0	Not detected																													
		Detected	1	Detected																													
F	RW DIF			Reset due to wake up from System OFF mode when wakeup is triggered from entering into debug interface mode																													
		NotDetected	0	Not detected																													
		Detected	1	Detected																													

5.3.9.9 SYSTEMOFF

Address offset: 0x500

System OFF register

Bit number	31 30 29 28 27 26 25 24 23 22 21 20 19 18 17 16 15 14 13 12 11 10 9 8 7 6 5 4 3 2 1 0																														
ID																															A
Reset 0x00000000	0 0																														
ID	Acce Field	Value ID	Value	Description																											
A	W	SYSTEMOFF		Enable System OFF mode																											
		Enter	1	Enable System OFF mode																											

5.3.9.10 POFCON

Address offset: 0x510

Power failure comparator configuration

Bit number	31 30 29 28 27 26 25 24 23 22 21 20 19 18 17 16 15 14 13 12 11 10 9 8 7 6 5 4 3 2 1 0																														
ID																															B B B B A
Reset 0x00000000	0 0																														
ID	Acce Field	Value ID	Value	Description																											
A	RW	POF		Enable or disable power failure comparator																											
		Disabled	0	Disable																											
		Enabled	1	Enable																											
B	RW	THRESHOLD		Power failure comparator threshold setting																											
		V17	4	Set threshold to 1.7 V																											
		V18	5	Set threshold to 1.8 V																											
		V19	6	Set threshold to 1.9 V																											
		V20	7	Set threshold to 2.0 V																											
		V21	8	Set threshold to 2.1 V																											
		V22	9	Set threshold to 2.2 V																											
		V23	10	Set threshold to 2.3 V																											
		V24	11	Set threshold to 2.4 V																											
		V25	12	Set threshold to 2.5 V																											
		V26	13	Set threshold to 2.6 V																											
		V27	14	Set threshold to 2.7 V																											
		V28	15	Set threshold to 2.8 V																											

5.3.9.11 GPREGRET

Address offset: 0x51C

General purpose retention register

Bit number	31 30 29 28 27 26 25 24 23 22 21 20 19 18 17 16 15 14 13 12 11 10 9 8 7 6 5 4 3 2 1 0																														
ID																															A A A A A A A A
Reset 0x00000000	0 0																														
ID	Acce Field	Value ID	Value	Description																											
A	RW	GPREGRET		General purpose retention register																											
				This register is a retained register																											

5.3.9.12 GPREGRET2

Address offset: 0x520

General purpose retention register

Bit number	31	30	29	28	27	26	25	24	23	22	21	20	19	18	17	16	15	14	13	12	11	10	9	8	7	6	5	4	3	2	1	0																								
ID																											A	A	A	A	A	A	A	A	A	A	A	A	A	A	A	A	A	A	A	A	A	A	A	A	A	A	A	A	A	A
Reset	0x00000000																										0	0	0	0	0	0	0	0	0	0	0	0	0	0	0	0	0	0	0	0	0	0	0	0	0	0	0	0	0	0
ID	Acce	Field	Value ID	Value	Description																																																			
A	RW	GPREGRET			General purpose retention register																																																			
This register is a retained register																																																								

5.3.9.13 DCDCEN

Address offset: 0x578

DC/DC enable register

Bit number	31	30	29	28	27	26	25	24	23	22	21	20	19	18	17	16	15	14	13	12	11	10	9	8	7	6	5	4	3	2	1	0																								
ID																											A																													
Reset	0x00000000																										0	0	0	0	0	0	0	0	0	0	0	0	0	0	0	0	0	0	0	0	0	0	0	0	0	0	0	0	0	0
ID	Acce	Field	Value ID	Value	Description																																																			
A	RW	DCDCEN			Enable or disable DC/DC converter																																																			
			Disabled	0	Disable																																																			
			Enabled	1	Enable																																																			

5.3.9.14 RAM[n].POWER (n=0..7)

Address offset: 0x900 + (n × 0x10)

RAMn power control register. The RAM size will vary depending on product variant, and the RAMn register will only be present if the corresponding RAM AHB slave is present on the device.

Bit number	31	30	29	28	27	26	25	24	23	22	21	20	19	18	17	16	15	14	13	12	11	10	9	8	7	6	5	4	3	2	1	0																								
ID														D	C														B	A																										
Reset	0x0000FFFF																										0	0	0	0	0	0	0	0	0	0	0	0	0	0	0	0	0	1	1	1	1	1	1	1	1	1	1	1	1	1
ID	Acce	Field	Value ID	Value	Description																																																			
A-B	RW	S[i]POWER (i=0..1)			Keep RAM section Si ON or OFF in System ON mode.																																																			
			Off	0	Off																																																			
			On	1	On																																																			
C-D	RW	S[i]RETENTION (i=0..1)			Keep retention on RAM section Si when RAM section is in																																																			
			Off	0	OFF																																																			
			On	1	Off																																																			
			On	1	On																																																			

5.3.9.15 RAM[n].POWERSET (n=0..7)

Address offset: 0x904 + (n × 0x10)

RAMn power control set register

When read, this register will return the value of the POWER register.

Bit number	31 30 29 28 27 26 25 24 23 22 21 20 19 18 17 16 15 14 13 12 11 10 9 8 7 6 5 4 3 2 1 0																														
ID	D C																												B A		
Reset 0x0000FFFF	0 0 0 0 0 0 0 0 0 0 0 0 0 0 0 0 0 1 1 1 1 1 1 1 1 1 1 1 1 1 1 1																														
ID	Acce	Field	Value	ID	Value	Description																									
A-B	W	S[i]POWER (i=0..1)	On	1	On	Keep RAM section Si of RAMn on or off in System ON mode																									
C-D	W	S[i]RETENTION (i=0..1)	On	1	On	Keep retention on RAM section Si when RAM section is switched off																									

5.3.9.16 RAM[n].POWERCLR (n=0..7)

Address offset: 0x908 + (n × 0x10)

RAMn power control clear register

When read, this register will return the value of the POWER register.

Bit number	31 30 29 28 27 26 25 24 23 22 21 20 19 18 17 16 15 14 13 12 11 10 9 8 7 6 5 4 3 2 1 0																														
ID	D C																												B A		
Reset 0x0000FFFF	0 0 0 0 0 0 0 0 0 0 0 0 0 0 0 0 0 1 1 1 1 1 1 1 1 1 1 1 1 1 1 1																														
ID	Acce	Field	Value	ID	Value	Description																									
A-B	W	S[i]POWER (i=0..1)	Off	1	Off	Keep RAM section Si of RAMn on or off in System ON mode																									
C-D	W	S[i]RETENTION (i=0..1)	Off	1	Off	Keep retention on RAM section Si when RAM section is switched off																									

5.3.10 Electrical specification

5.3.10.1 Device startup times

Symbol	Description	Min.	Typ.	Max.	Units
t _{POR}	Time in Power on Reset after VDD reaches 1.7 V for all supply voltages and temperatures. Dependent on supply rise time. ⁹				
t _{POR,10us}	VDD rise time 10us		1		ms
t _{POR,10ms}	VDD rise time 10ms		9		ms
t _{POR,60ms}	VDD rise time 60ms		23		ms
t _{PINR}	If a GPIO pin is configured as reset, the maximum time taken to pull up the pin and release reset after power on reset. Dependent on the pin capacitive load (C) ¹⁰ : t=5RC, R = 13kOhm				
t _{PINR,500nF}	C = 500nF			32.5	ms
t _{PINR,10uF}	C = 10uF			650	ms
t _{R2ON}	Time from reset to ON (CPU execute)				
t _{R2ON,NOTCONF}	If reset pin not configured		t _{POR}		ms
t _{R2ON,CONF}	If reset pin configured		t _{POR} + t _{PINR}		ms

⁹ A step increase in supply voltage of 300 mV or more, with rise time of 300 ms or less, within the valid supply range, may result in a system reset.

¹⁰ To decrease maximum time a device could hold in reset, a strong external pullup resistor can be used.

Symbol	Description	Min.	Typ.	Max.	Units
t _{OFF2ON}	Time from OFF to CPU execute		16.5		μs
t _{IDLE2CPU}	Time from IDLE to CPU execute		3.0		μs
t _{EVTSET,CL1}	Time from HW event to PPI event in Constant Latency System ON mode		0.0625		μs
t _{EVTSET,CL0}	Time from HW event to PPI event in Low Power System ON mode		0.0625		μs

5.3.10.2 Power fail comparator

Symbol	Description	Min.	Typ.	Max.	Units
V _{POF}	Nominal power level warning thresholds (falling supply voltage). Levels are configurable between Min. and Max. in 100mV increments.	1.7		2.8	V
V _{POFTOL}	Threshold voltage tolerance		±1	±5	%
V _{POFHYST}	Threshold voltage hysteresis		50		mV
V _{BOR,OFF}	Brown out reset voltage range SYSTEM OFF mode	1.2		1.7	V
V _{BOR,ON}	Brown out reset voltage range SYSTEM ON mode	1.48		1.7	V

5.4 CLOCK — Clock control

The clock control system can source the system clocks from a range of internal or external high and low frequency oscillators and distribute them to modules based upon a module's individual requirements. Clock distribution is automated and grouped independently by module to limit current consumption in unused branches of the clock tree.

Listed here are the main features for CLOCK:

- 64 MHz on-chip oscillator
- 64 MHz crystal oscillator, using external 32 MHz crystal
- 32.768 kHz +/-500 ppm RC oscillator
- 32.768 kHz crystal oscillator, using external 32.768 kHz crystal
- 32.768 kHz oscillator synthesized from 64 MHz oscillator
- Firmware (FW) override control of oscillator activity for low latency start up
- Automatic oscillator and clock control, and distribution for ultra-low power

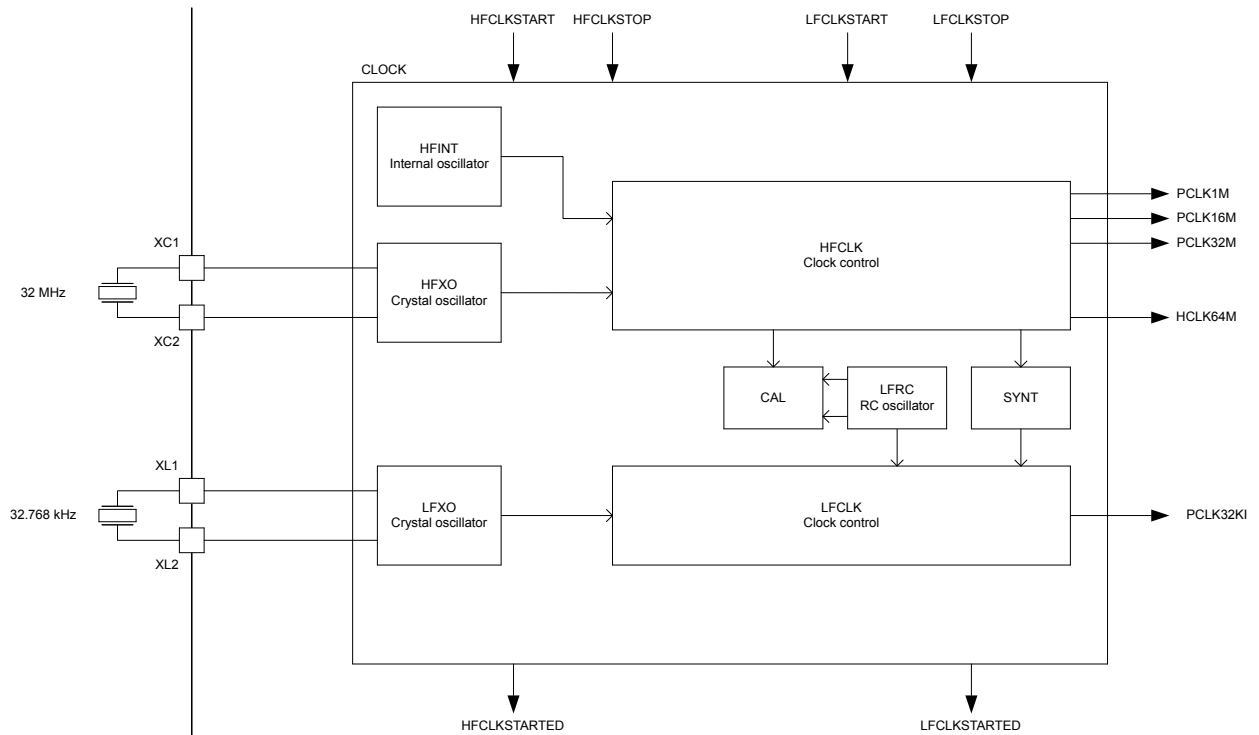

Figure 17: Clock control

5.4.1 HFCLK clock controller

The HFCLK clock controller provides the following clocks to the system.

- HCLK64M: 64 MHz CPU clock
- PCLK1M: 1 MHz peripheral clock
- PCLK16M: 16 MHz peripheral clock
- PCLK32M: 32 MHz peripheral clock

The HFCLK controller supports the following high frequency clock (HFCLK) sources:

- 64 MHz internal oscillator (HFINT)
- 64 MHz crystal oscillator (HF XO)

For illustration, see [Clock control](#) on page 63.

When the system requests one or more clocks from the HFCLK controller, the HFCLK controller will automatically provide them. If the system does not request any clocks provided by the HFCLK controller, the controller will enter a power saving mode.

These clocks are only available when the system is in ON mode. When the system enters ON mode, the internal oscillator (HFINT) clock source will automatically start to be able to provide the required HFCLK clock(s) for the system.

The HFINT will be used when HFCLK is requested and HF XO has not been started. The HF XO is started by triggering the HFCLKSTART task and stopped using the HFCLKSTOP task. A HFCLKSTARTED event will be generated when the HF XO has started and its frequency is stable.

The HF XO must be running to use the RADIO or the calibration mechanism associated with the 32.768 kHz RC oscillator.

5.4.1.1 64 MHz crystal oscillator (HF XO)

The 64 MHz crystal oscillator (HF XO) is controlled by a 32 MHz external crystal

The crystal oscillator is designed for use with an AT-cut quartz crystal in parallel resonant mode. To achieve correct oscillation frequency, the load capacitance must match the specification in the crystal data sheet.

[Circuit diagram of the 64 MHz crystal oscillator](#) on page 64 shows how the 32 MHz crystal is connected to the 64 MHz crystal oscillator.

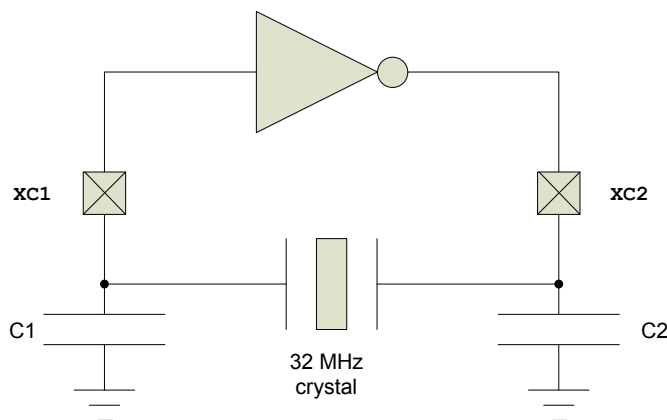

Figure 18: Circuit diagram of the 64 MHz crystal oscillator

The load capacitance (CL) is the total capacitance seen by the crystal across its terminals and is given by:

$$CL = \frac{(C1' \cdot C2')}{(C1' + C2')}$$

$$C1' = C1 + C_{pcb1} + C_{pin}$$

$$C2' = C2 + C_{pcb2} + C_{pin}$$

C1 and C2 are ceramic SMD capacitors connected between each crystal terminal and ground. For more information, see [Reference circuitry](#) on page 396. C_{pcb1} and C_{pcb2} are stray capacitances on the PCB. C_{pin} is the pin input capacitance on the XC1 and XC2 pins. See [table 64 MHz crystal oscillator \(HF XO\)](#) on page 73. The load capacitors C1 and C2 should have the same value.

For reliable operation, the crystal load capacitance, shunt capacitance, equivalent series resistance, and drive level must comply with the specifications in [table 64 MHz crystal oscillator \(HF XO\)](#) on page 73. It is recommended to use a crystal with lower than maximum load capacitance and/or shunt capacitance. A low load capacitance will reduce both start up time and current consumption.

5.4.2 LFCLK clock controller

The system supports several low frequency clock sources.

As illustrated in [Clock control](#) on page 63, the system supports the following low frequency clock sources:

- 32.768 kHz RC oscillator (LFRC)
- 32.768 kHz crystal oscillator (LFXO)
- 32.768 kHz synthesized from HFCLK (LFSYNT)

The LFCLK clock is started by first selecting the preferred clock source in register [LFCLKSRC](#) on page 72 and then triggering the LFCLKSTART task. If the LFXO is selected as the clock source, the LFCLK will initially start running from the 32.768 kHz LFRC while the LFXO is starting up and automatically switch to using the LFXO once this oscillator is running. The LFCLKSTARTED event will be generated when the LFXO has been started.

The LFCLK clock is stopped by triggering the LFCLKSTOP task.

It is not allowed to write to register [LFCLKSRC](#) on page 72 when the LFCLK is running.

A LFCLKSTOP task will stop the LFCLK oscillator. However, the LFCLKSTOP task can only be triggered after the STATE field in register [LFCLKSTAT](#) on page 72 indicates a 'LFCLK running' state.

The LFCLK clock controller and all of the LFCLK clock sources are always switched off when in OFF mode.

5.4.2.1 32.768 kHz RC oscillator (LFRC)

The default source of the low frequency clock (LFCLK) is the 32.768 kHz RC oscillator (LFRC).

The LFRC frequency will be affected by variation in temperature. The LFRC oscillator can be calibrated to improve accuracy by using the HFCLK as a reference oscillator during calibration. See [Table 32.768 kHz RC oscillator \(LFRC\)](#) on page 74 for details on the default and calibrated accuracy of the LFRC oscillator.

The LFRC oscillator does not require additional external components.

5.4.2.2 Calibrating the 32.768 kHz RC oscillator

After the 32.768 kHz RC oscillator is started and running, it can be calibrated by triggering the CAL task. In this case, the HFCLK will be temporarily switched on and used as a reference.

A DONE event will be generated when calibration has finished. The calibration mechanism will only work as long as HFCLK is generated from the HFCLK crystal oscillator, it is therefore necessary to explicitly start this crystal oscillator before calibration can be started, see HFCLKSTART task.

It is not allowed to stop the LFRC during an ongoing calibration.

5.4.2.3 Calibration timer

The calibration timer can be used to time the calibration interval of the 32.768 kHz RC oscillator.

The calibration timer is started by triggering the CTSTART task and stopped by triggering the CTSTOP task. The calibration timer will always start counting down from the value specified in CTIV and generate a CTTO timeout event when it reaches 0. The Calibration timer will stop by itself when it reaches 0.

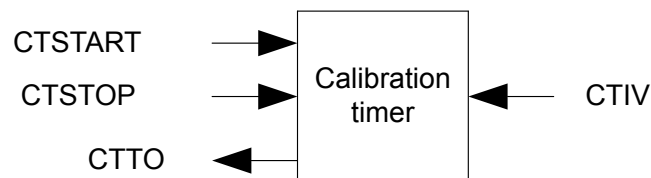

Figure 19: Calibration timer

Due to limitations in the calibration timer, only one task related to calibration, that is, CAL, CTSTART and CTSTOP, can be triggered for every period of LFCLK.

5.4.2.4 32.768 kHz crystal oscillator (LFXO)

For higher LFCLK accuracy the low frequency crystal oscillator (LFXO) must be used.

The following external clock sources are supported:

- Low swing clock signal applied to the *XL1* pin. The *XL2* pin shall then be grounded.
- Rail-to-rail clock signal applied to the *XL1* pin. The *XL2* pin shall then be grounded or left unconnected.

The [LFCLKSRC](#) on page 72 register controls the clock source, and its allowed swing. The truth table for various situations is as follows:

SRC	EXTERNAL	BYPASS	Comment
0	0	0	Normal operation, RC is source
0	0	1	DO NOT USE
0	1	X	DO NOT USE
1	0	0	Normal XTAL operation
1	1	0	Apply external low swing signal to XL1, ground XL2
1	1	1	Apply external full swing signal to XL1, leave XL2 grounded or unconnected
1	0	1	DO NOT USE
2	0	0	Normal operation, synth is source
2	0	1	DO NOT USE
2	1	X	DO NOT USE

Table 17: LFCLKSRC configuration depending on clock source

To achieve correct oscillation frequency, the load capacitance must match the specification in the crystal data sheet. [Circuit diagram of the 32.768 kHz crystal oscillator](#) on page 66 shows the LFXO circuitry.

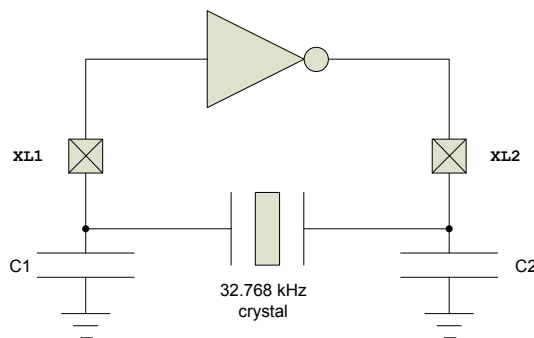

Figure 20: Circuit diagram of the 32.768 kHz crystal oscillator

The load capacitance (CL) is the total capacitance seen by the crystal across its terminals and is given by:

$$CL = \frac{(C1' \cdot C2')}{(C1' + C2')}$$

$$C1' = C1 + C_{pcb1} + C_{pin}$$

$$C2' = C2 + C_{pcb2} + C_{pin}$$

C1 and C2 are ceramic SMD capacitors connected between each crystal terminal and ground. C_{pcb1} and C_{pcb2} are stray capacitances on the PCB. C_{pin} is the pin input capacitance on the XC1 and XC2 pins (see [32.768 kHz crystal oscillator \(LFXO\)](#) on page 74). The load capacitors C1 and C2 should have the same value.

For more information, see [Reference circuitry](#) on page 396.

5.4.2.5 32.768 kHz synthesized from HFCLK (LFSYNT)

LFCLK can also be synthesized from the HFCLK clock source. The accuracy of LFCLK will then be the accuracy of the HFCLK.

Using the LFSYNT clock avoids the requirement for a 32.768 kHz crystal, but increases average power consumption as the HFCLK will need to be requested in the system.

5.4.3 Registers

Base address	Peripheral	Instance	Description	Configuration
0x40000000	CLOCK	CLOCK	Clock control	

Table 18: Instances

Register	Offset	Description	
TASKS_HFCLKSTART	0x000	Start HFCLK crystal oscillator	
TASKS_HFCLKSTOP	0x004	Stop HFCLK crystal oscillator	
TASKS_LFCLKSTART	0x008	Start LFCLK source	
TASKS_LFCLKSTOP	0x00C	Stop LFCLK source	
TASKS_CAL	0x010	Start calibration of LFRC oscillator	
TASKS_CTSTART	0x014	Start calibration timer	
TASKS_CTSTOP	0x018	Stop calibration timer	
EVENTS_HFCLKSTARTED	0x100	HFCLK oscillator started	
EVENTS_LFCLKSTARTED	0x104	LFCLK started	
EVENTS_DONE	0x10C	Calibration of LFCLK RC oscillator complete event	
EVENTS_CTTO	0x110	Calibration timer timeout	
INTENSET	0x304	Enable interrupt	
INTENCLR	0x308	Disable interrupt	
HFCLKRUN	0x408	Status indicating that HFCLKSTART task has been triggered	
HFCLKSTAT	0x40C	HFCLK status	
LFCLKRUN	0x414	Status indicating that LFCLKSTART task has been triggered	
LFCLKSTAT	0x418	LFCLK status	
LFCLKSRCCOPY	0x41C	Copy of LFCLKSRC register, set when LFCLKSTART task was triggered	
LFCLKSRC	0x518	Clock source for the LFCLK	
CTIV	0x538	Calibration timer interval	Retained

Table 19: Register overview

5.4.3.1 TASKS_HFCLKSTART

Address offset: 0x000

Start HFCLK crystal oscillator

Bit number	31	30	29	28	27	26	25	24	23	22	21	20	19	18	17	16	15	14	13	12	11	10	9	8	7	6	5	4	3	2	1	0
ID																																A
Reset 0x00000000	0	0	0	0	0	0	0	0	0	0	0	0	0	0	0	0	0	0	0	0	0	0	0	0	0	0	0	0	0	0	0	0
ID	Acce	Field	Value ID	Value	Description																											
A	W	TASKS_HFCLKSTART			Start HFCLK crystal oscillator																											
			Trigger	1	Trigger task																											

5.4.3.2 TASKS_HFCLKSTOP

Address offset: 0x004

Stop HFCLK crystal oscillator

Bit number	31	30	29	28	27	26	25	24	23	22	21	20	19	18	17	16	15	14	13	12	11	10	9	8	7	6	5	4	3	2	1	0
ID																																A
Reset 0x00000000	0 0																															
ID	Acce Field	Value ID	Value	Description																												
A	W	TASKS_HFCLKSTOP	1	Stop HFCLK crystal oscillator																												
		Trigger		Trigger task																												

5.4.3.3 TASKS_LFCLKSTART

Address offset: 0x008

Start LFCLK source

Bit number	31	30	29	28	27	26	25	24	23	22	21	20	19	18	17	16	15	14	13	12	11	10	9	8	7	6	5	4	3	2	1	0
ID																																A
Reset 0x00000000	0 0																															
ID	Acce Field	Value ID	Value	Description																												
A	W	TASKS_LFCLKSTART	1	Start LFCLK source																												
		Trigger		Trigger task																												

5.4.3.4 TASKS_LFCLKSTOP

Address offset: 0x00C

Stop LFCLK source

Bit number	31	30	29	28	27	26	25	24	23	22	21	20	19	18	17	16	15	14	13	12	11	10	9	8	7	6	5	4	3	2	1	0
ID																																A
Reset 0x00000000	0 0																															
ID	Acce Field	Value ID	Value	Description																												
A	W	TASKS_LFCLKSTOP	1	Stop LFCLK source																												
		Trigger		Trigger task																												

5.4.3.5 TASKS_CAL

Address offset: 0x010

Start calibration of LFRC oscillator

Bit number	31	30	29	28	27	26	25	24	23	22	21	20	19	18	17	16	15	14	13	12	11	10	9	8	7	6	5	4	3	2	1	0
ID																																A
Reset 0x00000000	0 0																															
ID	Acce Field	Value ID	Value	Description																												
A	W	TASKS_CAL	1	Start calibration of LFRC oscillator																												
		Trigger		Trigger task																												

5.4.3.6 TASKS_CTSTART

Address offset: 0x014

Start calibration timer

Bit number	31	30	29	28	27	26	25	24	23	22	21	20	19	18	17	16	15	14	13	12	11	10	9	8	7	6	5	4	3	2	1	0
ID																																A
Reset 0x00000000	0 0																															
ID	Acce	Field	Value ID	Value	Description																											
A	W	TASKS_CTSTART			Start calibration timer																											
			Trigger	1	Trigger task																											

5.4.3.7 TASKS_CTSTOP

Address offset: 0x018

Stop calibration timer

Bit number	31	30	29	28	27	26	25	24	23	22	21	20	19	18	17	16	15	14	13	12	11	10	9	8	7	6	5	4	3	2	1	0
ID																																A
Reset 0x00000000	0 0																															
ID	Acce	Field	Value ID	Value	Description																											
A	W	TASKS_CTSTOP			Stop calibration timer																											
			Trigger	1	Trigger task																											

5.4.3.8 EVENTS_HFCLKSTARTED

Address offset: 0x100

HFCLK oscillator started

Bit number	31	30	29	28	27	26	25	24	23	22	21	20	19	18	17	16	15	14	13	12	11	10	9	8	7	6	5	4	3	2	1	0
ID																																A
Reset 0x00000000	0 0																															
ID	Acce	Field	Value ID	Value	Description																											
A	RW	EVENTS_HFCLKSTARTED			HFCLK oscillator started																											
			NotGenerated	0	Event not generated																											
			Generated	1	Event generated																											

5.4.3.9 EVENTS_LFCLKSTARTED

Address offset: 0x104

LFCLK started

Bit number	31	30	29	28	27	26	25	24	23	22	21	20	19	18	17	16	15	14	13	12	11	10	9	8	7	6	5	4	3	2	1	0
ID																																A
Reset 0x00000000	0 0																															
ID	Acce	Field	Value ID	Value	Description																											
A	RW	EVENTS_LFCLKSTARTED			LFCLK started																											
			NotGenerated	0	Event not generated																											
			Generated	1	Event generated																											

5.4.3.10 EVENTS_DONE

Address offset: 0x10C

Calibration of LFCLK RC oscillator complete event

Bit number	31	30	29	28	27	26	25	24	23	22	21	20	19	18	17	16	15	14	13	12	11	10	9	8	7	6	5	4	3	2	1	0	
ID																																A	
Reset	0x00000000																																
0	0	0	0	0	0	0	0	0	0	0	0	0	0	0	0	0	0	0	0	0	0	0	0	0	0	0	0	0	0	0	0	0	0
ID	Acce Field	Value ID	Value	Description																													
A	RW	EVENTS_DONE		Calibration of LFCLK RC oscillator complete event																													
		NotGenerated	0	Event not generated																													
		Generated	1	Event generated																													

5.4.3.11 EVENTS_CTTO

Address offset: 0x110

Calibration timer timeout

Bit number	31	30	29	28	27	26	25	24	23	22	21	20	19	18	17	16	15	14	13	12	11	10	9	8	7	6	5	4	3	2	1	0
ID																																A
Reset	0x00000000																															
0	0	0	0	0	0	0	0	0	0	0	0	0	0	0	0	0	0	0	0	0	0	0	0	0	0	0	0	0	0	0	0	0
ID	Acce Field	Value ID	Value	Description																												
A	RW	EVENTS_CTTO		Calibration timer timeout																												
		NotGenerated	0	Event not generated																												
		Generated	1	Event generated																												

5.4.3.12 INTENSET

Address offset: 0x304

Enable interrupt

Bit number	31	30	29	28	27	26	25	24	23	22	21	20	19	18	17	16	15	14	13	12	11	10	9	8	7	6	5	4	3	2	1	0			
ID																																D	C	B	A
Reset	0x00000000																																		
0	0	0	0	0	0	0	0	0	0	0	0	0	0	0	0	0	0	0	0	0	0	0	0	0	0	0	0	0	0	0	0	0			
ID	Acce Field	Value ID	Value	Description																															
A	RW	HFCLKSTARTED		Write '1' to enable interrupt for event HFCLKSTARTED																															
		Set	1	Enable																															
		Disabled	0	Read: Disabled																															
		Enabled	1	Read: Enabled																															
B	RW	LFCLKSTARTED		Write '1' to enable interrupt for event LFCLKSTARTED																															
		Set	1	Enable																															
		Disabled	0	Read: Disabled																															
		Enabled	1	Read: Enabled																															
C	RW	DONE		Write '1' to enable interrupt for event DONE																															
		Set	1	Enable																															
		Disabled	0	Read: Disabled																															
		Enabled	1	Read: Enabled																															
D	RW	CTTO		Write '1' to enable interrupt for event CTTO																															
		Set	1	Enable																															
		Disabled	0	Read: Disabled																															
		Enabled	1	Read: Enabled																															

5.4.3.13 INTENCLR

Address offset: 0x308

Disable interrupt

Bit number		31 30 29 28 27 26 25 24 23 22 21 20 19 18 17 16 15 14 13 12 11 10 9 8 7 6 5 4 3 2 1 0																													
ID																												D	C	B	A
Reset 0x00000000		0 0																													
ID	Acce Field	Value ID	Value	Description																											
A	RW HFCLKSTARTED			Write '1' to disable interrupt for event HFCLKSTARTED																											
		Clear	1	Disable																											
		Disabled	0	Read: Disabled																											
		Enabled	1	Read: Enabled																											
B	RW LFCLKSTARTED			Write '1' to disable interrupt for event LFCLKSTARTED																											
		Clear	1	Disable																											
		Disabled	0	Read: Disabled																											
		Enabled	1	Read: Enabled																											
C	RW DONE			Write '1' to disable interrupt for event DONE																											
		Clear	1	Disable																											
		Disabled	0	Read: Disabled																											
		Enabled	1	Read: Enabled																											
D	RW CTTO			Write '1' to disable interrupt for event CTTO																											
		Clear	1	Disable																											
		Disabled	0	Read: Disabled																											
		Enabled	1	Read: Enabled																											

5.4.3.14 HFCLKRUN

Address offset: 0x408

Status indicating that HFCLKSTART task has been triggered

Bit number		31 30 29 28 27 26 25 24 23 22 21 20 19 18 17 16 15 14 13 12 11 10 9 8 7 6 5 4 3 2 1 0																													
ID																															A
Reset 0x00000000		0 0																													
ID	Acce Field	Value ID	Value	Description																											
A	R STATUS			HFCLKSTART task triggered or not																											
		NotTriggered	0	Task not triggered																											
		Triggered	1	Task triggered																											

5.4.3.15 HFCLKSTAT

Address offset: 0x40C

HFCLK status

Bit number		31 30 29 28 27 26 25 24 23 22 21 20 19 18 17 16 15 14 13 12 11 10 9 8 7 6 5 4 3 2 1 0																													
ID																												B			A
Reset 0x00000000		0 0																													
ID	Acce Field	Value ID	Value	Description																											
A	R SRC			Source of HFCLK																											
		RC	0	64 MHz internal oscillator (HFINT)																											
		Xtal	1	64 MHz crystal oscillator (HFXO)																											
B	R STATE			HFCLK state																											
		NotRunning	0	HFCLK not running																											
		Running	1	HFCLK running																											

5.4.3.16 LFCLKRUN

Address offset: 0x414

Status indicating that LFCLKSTART task has been triggered

Bit number	31 30 29 28 27 26 25 24 23 22 21 20 19 18 17 16 15 14 13 12 11 10 9 8 7 6 5 4 3 2 1 0																														
ID																															A
Reset 0x00000000	0 0																														
ID	Acce	Field	Value ID	Value	Description																										
A	R	STATUS			LFCLKSTART task triggered or not																										
			NotTriggered	0	Task not triggered																										
			Triggered	1	Task triggered																										

5.4.3.17 LFCLKSTAT

Address offset: 0x418

LFCLK status

Bit number	31 30 29 28 27 26 25 24 23 22 21 20 19 18 17 16 15 14 13 12 11 10 9 8 7 6 5 4 3 2 1 0																															
ID																													B			A A
Reset 0x00000000	0 0																															
ID	Acce	Field	Value ID	Value	Description																											
A	R	SRC			Source of LFCLK																											
			RC	0	32.768 kHz RC oscillator																											
			Xtal	1	32.768 kHz crystal oscillator																											
			Synth	2	32.768 kHz synthesized from HFCLK																											
B	R	STATE			LFCLK state																											
			NotRunning	0	LFCLK not running																											
			Running	1	LFCLK running																											

5.4.3.18 LFCLKSRCCOPY

Address offset: 0x41C

Copy of LFCLKSRC register, set when LFCLKSTART task was triggered

Bit number	31 30 29 28 27 26 25 24 23 22 21 20 19 18 17 16 15 14 13 12 11 10 9 8 7 6 5 4 3 2 1 0																														
ID																															A A
Reset 0x00000000	0 0																														
ID	Acce	Field	Value ID	Value	Description																										
A	R	SRC			Clock source																										
			RC	0	32.768 kHz RC oscillator																										
			Xtal	1	32.768 kHz crystal oscillator																										
			Synth	2	32.768 kHz synthesized from HFCLK																										

5.4.3.19 LFCLKSRC

Address offset: 0x518

Clock source for the LFCLK

Bit number	31 30 29 28 27 26 25 24 23 22 21 20 19 18 17 16 15 14 13 12 11 10 9 8 7 6 5 4 3 2 1 0																																	
ID																													C	B			A	A
Reset 0x00000000	0 0																																	
ID	Acce Field	Value ID	Value	Description																														
A	RW SRC	RC	0	32.768 kHz RC oscillator																														
		Xtal	1	32.768 kHz crystal oscillator																														
		Synth	2	32.768 kHz synthesized from HFCLK																														
B	RW BYPASS	Disabled	0	Enable or disable bypass of LFCLK crystal oscillator with external clock source Disable (use with Xtal or low-swing external source)																														
		Enabled	1	Enable (use with rail-to-rail external source)																														
C	RW EXTERNAL	Disabled	0	Enable or disable external source for LFCLK Disable external source (use with Xtal)																														
		Enabled	1	Enable use of external source instead of Xtal (SRC needs to be set to Xtal)																														

5.4.3.20 CTIV (Retained)

Address offset: 0x538

This register is a retained register

Calibration timer interval

Bit number	31 30 29 28 27 26 25 24 23 22 21 20 19 18 17 16 15 14 13 12 11 10 9 8 7 6 5 4 3 2 1 0																																	
ID																													A	A	A	A	A	A
Reset 0x00000000	0 0																																	
ID	Acce Field	Value ID	Value	Description																														
A	RW CTIV			Calibration timer interval in multiple of 0.25 seconds. Range: 0.25 seconds to 31.75 seconds.																														

5.4.4 Electrical specification

5.4.4.1 64 MHz internal oscillator (HFINT)

Symbol	Description	Min.	Typ.	Max.	Units
f_{NOM_HFINT}	Nominal output frequency		64		MHz
f_{TOL_HFINT}	Frequency tolerance		<±1.5	<±8	%
t_{START_HFINT}	Startup time		3		us

5.4.4.2 64 MHz crystal oscillator (HF XO)

Symbol	Description	Min.	Typ.	Max.	Units
$f_{NOM_HF XO}$	Nominal output frequency		64		MHz
$f_{XTAL_HF XO}$	External crystal frequency		32		MHz
$f_{TOL_HF XO}$	Frequency tolerance requirement for 2.4 GHz proprietary radio applications			±60	ppm
$f_{TOL_HF XO_BLE}$	Frequency tolerance requirement, Bluetooth low energy applications			±40	ppm
$C_L_HF XO$	Load capacitance			12	pF
$C_0_HF XO$	Shunt capacitance			7	pF

Symbol	Description	Min.	Typ.	Max.	Units
R _{S_HFXO_7PF}	Equivalent series resistance C0 = 7 pF			60	ohm
R _{S_HFXO_5PF}	Equivalent series resistance C0 = 5 pF			60	ohm
R _{S_HFXO_3PF}	Equivalent series resistance C0 = 3 pF			100	ohm
P _{D_HFXO}	Drive level			100	uW
C _{PIN_HFXO}	Input capacitance XC1 and XC2		4		pF
t _{START_HFXO}	Startup time		0.36		ms

5.4.4.3 32.768 kHz RC oscillator (LFRC)

Symbol	Description	Min.	Typ.	Max.	Units
f _{NOM_LFRC}	Nominal frequency		32.768		kHz
f _{TOL_LFRC}	Frequency tolerance			±2	%
f _{TOL_CAL_LFRC}	Frequency tolerance for LFRC after calibration ¹¹			±500	ppm
t _{START_LFRC}	Startup time for 32.768 kHz RC oscillator		600		us

5.4.4.4 32.768 kHz crystal oscillator (LFXO)

Symbol	Description	Min.	Typ.	Max.	Units
f _{NOM_LFXO}	Crystal frequency		32.768		kHz
f _{TOL_LFXO_BLE}	Frequency tolerance requirement for BLE stack			±250	ppm
f _{TOL_LFXO_ANT}	Frequency tolerance requirement for ANT stack			±50	ppm
C _{L_LFXO}	Load capacitance			12.5	pF
C _{D_LFXO}	Shunt capacitance			2	pF
R _{S_LFXO}	Equivalent series resistance			100	kohm
P _{D_LFXO}	Drive level			1	uW
C _{pin}	Input capacitance on XL1 and XL2 pads		4		pF
t _{START_LFXO}	Startup time for 32.768 kHz crystal oscillator		0.25		s
V _{AMP_IN_XO_LOW}	Peak to peak amplitude for external low swing clock. Input signal must not swing outside supply rails.	200		1000	mV

5.4.4.5 32.768 kHz synthesized from HFCLK (LFSYNT)

Symbol	Description	Min.	Typ.	Max.	Units
f _{NOM_LFSYNT}	Nominal frequency		32.768		kHz
f _{TOL_LFSYNT}	Frequency tolerance in addition to HFCLK tolerance ¹²		8		ppm
t _{START_LFSYNT}	Startup time for synthesized 32.768 kHz		100		us

¹¹ Constant temperature within ±0.5 °C and calibration performed at least every 8 seconds, defined as 3 sigma

¹² Frequency tolerance will be derived from the HFCLK source clock plus the LFSYNT tolerance

6 Peripherals

6.1 Peripheral interface

Peripherals are controlled by the CPU by writing to configuration registers and task registers. Peripheral events are indicated to the CPU by event registers and interrupts if they are configured for a given event.

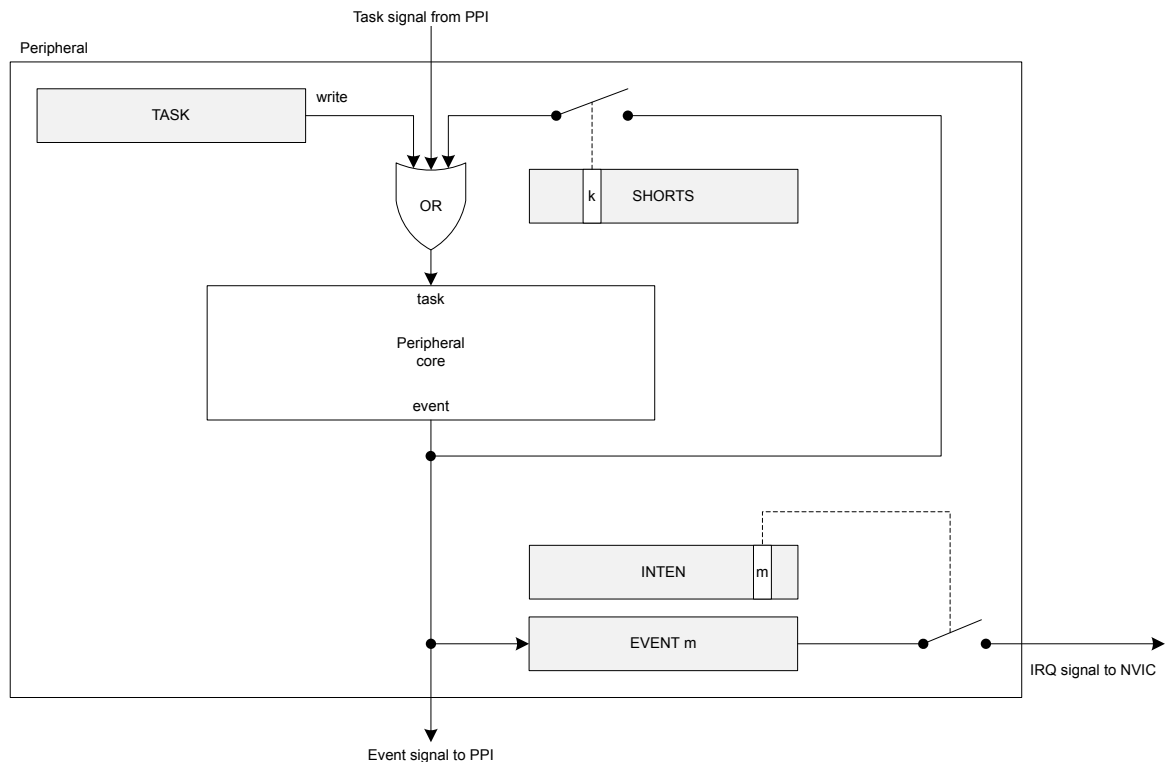

Figure 21: Tasks, events, shortcuts, and interrupts

6.1.1 Peripheral ID

Every peripheral is assigned a fixed block of 0x1000 bytes of address space, which is equal to 1024 x 32 bit registers.

See [Instantiation](#) on page 19 for more information about which peripherals are available and where they are located in the address map.

There is a direct relationship between peripheral ID and base address. For example, a peripheral with base address 0x40000000 is assigned ID=0, a peripheral with base address 0x40001000 is assigned ID=1, and a peripheral with base address 0x4001F000 is assigned ID=31.

Peripherals may share the same ID, which may impose one or more of the following limitations:

- Some peripherals share some registers or other common resources.
- Operation is mutually exclusive. Only one of the peripherals can be used at a time.
- Switching from one peripheral to another must follow a specific pattern (disable the first, then enable the second peripheral).

6.1.2 Peripherals with shared ID

In general (with the exception of ID 0), peripherals sharing an ID and base address may not be used simultaneously. The user can only enable one peripheral at the time on this specific ID.

When switching between two peripherals sharing an ID, the user should do the following to prevent unwanted behavior:

- Disable the previously used peripheral.
- Remove any programmable peripheral interconnect (PPI) connections set up for the peripheral that is being disabled.
- Clear all bits in the INTEN register, i.e. `INTENCLR = 0xFFFFFFFF`.
- Explicitly configure the peripheral that you are about to enable and do not rely on configuration values that may be inherited from the peripheral that was disabled.
- Enable the now configured peripheral.

See which peripherals are sharing ID in [Instantiation](#) on page 19.

6.1.3 Peripheral registers

Most peripherals feature an ENABLE register. Unless otherwise specified in the relevant chapter, the peripheral registers (in particular the PSEL registers) must be configured before enabling the peripheral.

Note that the peripheral must be enabled before tasks and events can be used.

6.1.4 Bit set and clear

Registers with multiple single-bit bit fields may implement the set-and-clear pattern. This pattern enables firmware to set and clear individual bits in a register without having to perform a read-modify-write operation on the main register.

This pattern is implemented using three consecutive addresses in the register map, where the main register is followed by dedicated SET and CLR registers (in that exact order).

The SET register is used to set individual bits in the main register while the CLR register is used to clear individual bits in the main register. Writing 1 to a bit in SET or CLR register will set or clear the same bit in the main register respectively. Writing 0 to a bit in SET or CLR register has no effect. Reading the SET or CLR register returns the value of the main register.

Note: The main register may not be visible and hence not directly accessible in all cases.

6.1.5 Tasks

Tasks are used to trigger actions in a peripheral, for example to start a particular behavior. A peripheral can implement multiple tasks with each task having a separate register in that peripheral's task register group.

A task is triggered when firmware writes 1 to the task register, or when the peripheral itself or another peripheral toggles the corresponding task signal. See [Tasks, events, shortcuts, and interrupts](#) on page 75.

6.1.6 Events

Events are used to notify peripherals and the CPU about events that have happened, for example a state change in a peripheral. A peripheral may generate multiple events with each event having a separate register in that peripheral's event register group.

An event is generated when the peripheral itself toggles the corresponding event signal, and the event register is updated to reflect that the event has been generated. See [Tasks, events, shortcuts, and interrupts](#) on page 75. An event register is only cleared when firmware writes 0 to it.

Events can be generated by the peripheral even when the event register is set to 1.

6.1.7 Shortcuts

A shortcut is a direct connection between an event and a task within the same peripheral. If a shortcut is enabled, the associated task is automatically triggered when its associated event is generated.

Using a shortcut is the equivalent to making the same connection outside the peripheral and through the PPI. However, the propagation delay through the shortcut is usually shorter than the propagation delay through the PPI.

Shortcuts are predefined, which means their connections cannot be configured by firmware. Each shortcut can be individually enabled or disabled through the shortcut register, one bit per shortcut, giving a maximum of 32 shortcuts for each peripheral.

6.1.8 Interrupts

All peripherals support interrupts. Interrupts are generated by events.

A peripheral only occupies one interrupt, and the interrupt number follows the peripheral ID. For example, the peripheral with ID=4 is connected to interrupt number 4 in the nested vectored interrupt controller (NVIC).

Using the INTEN, INTENSET and INTENCLR registers, every event generated by a peripheral can be configured to generate that peripheral's interrupt. Multiple events can be enabled to generate interrupts simultaneously. To resolve the correct interrupt source, the event registers in the event group of peripheral registers will indicate the source.

Some peripherals implement only INTENSET and INTENCLR registers, and the INTEN register is not available on those peripherals. See the individual peripheral chapters for details. In all cases, reading back the INTENSET or INTENCLR register returns the same information as in INTEN.

Each event implemented in the peripheral is associated with a specific bit position in the INTEN, INTENSET and INTENCLR registers.

The relationship between tasks, events, shortcuts, and interrupts is shown in [Tasks, events, shortcuts, and interrupts](#) on page 75.

Interrupt clearing

Clearing an interrupt by writing 0 to an event register, or disabling an interrupt using the INTENCLR register, can take up to four CPU clock cycles to take effect. This means that an interrupt may reoccur immediately, even if a new event has not come, if the program exits an interrupt handler after the interrupt is cleared or disabled but before four clock cycles have passed.

Note: To avoid an interrupt reoccurring before a new event has come, the program should perform a read from one of the peripheral registers. For example, the event register that has been cleared, or the INTENCLR register that has been used to disable the interrupt. This will cause a one to three-cycle delay and ensure the interrupt is cleared before exiting the interrupt handler.

Care should be taken to ensure the compiler does not remove the read operation as an optimization. If the program can guarantee a four-cycle delay after event being cleared or interrupt disabled in any other way, then a read of a register is not required.

6.2 AAR — Accelerated address resolver

Accelerated address resolver is a cryptographic support function for implementing the Resolvable Private Address Resolution Procedure described in the *Bluetooth Core specification v4.0*. Resolvable Private Address generation should be achieved using ECB and is not supported by AAR.

The procedure allows two devices that share a secret key to generate and resolve a hash based on their device address. The AAR block enables real-time address resolution on incoming packets when configured as described in this chapter. This allows real-time packet filtering (whitelisting) using a list of known shared keys (Identity Resolving Keys (IRK) in *Bluetooth*).

6.2.1 EasyDMA

The AAR implements EasyDMA for reading and writing to the RAM. The EasyDMA will have finished accessing the RAM when the END, RESOLVED, and NOTRESOLVED events are generated.

If the [IRKPTR](#) on page 83, [ADDRPTR](#) on page 83, and the [SCRATCHPTR](#) on page 83 is not pointing to the Data RAM region, an EasyDMA transfer may result in a HardFault or RAM corruption. See [Memory](#) on page 17 for more information about the different memory regions.

6.2.2 Resolving a resolvable address

As per *Bluetooth* specification, a private resolvable address is composed of six bytes.

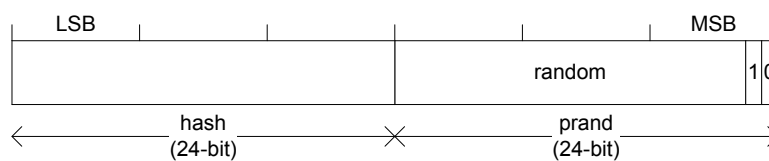

Figure 22: Resolvable address

To resolve an address the register [ADDRPTR](#) on page 83 must point to the start of the packet. The resolver is started by triggering the START task. A RESOLVED event is generated when the AAR manages to resolve the address using one of the Identity Resolving Keys (IRK) found in the IRK data structure. The AAR will use the IRK specified in the register IRK0 to IRK15 starting from IRK0. The register [NIRK](#) on page 82 specifies how many IRKs should be used. The AAR module will generate a NOTRESOLVED event if it is not able to resolve the address using the specified list of IRKs.

The AAR will go through the list of available IRKs in the IRK data structure and for each IRK try to resolve the address according to the Resolvable Private Address Resolution Procedure described in the *Bluetooth Core specification v4.0* [Vol 3] chapter 10.8.2.3. The time it takes to resolve an address varies due to the location in the list of the resolvable address. The resolution time will also be affected by RAM accesses performed by other peripherals and the CPU. See the [Electrical specifications](#) for more information about resolution time.

The AAR only compares the received address to those programmed in the module without checking the address type.

The AAR will stop as soon as it has managed to resolve the address, or after trying to resolve the address using [NIRK](#) number of IRKs from the IRK data structure. The AAR will generate an END event after it has stopped.

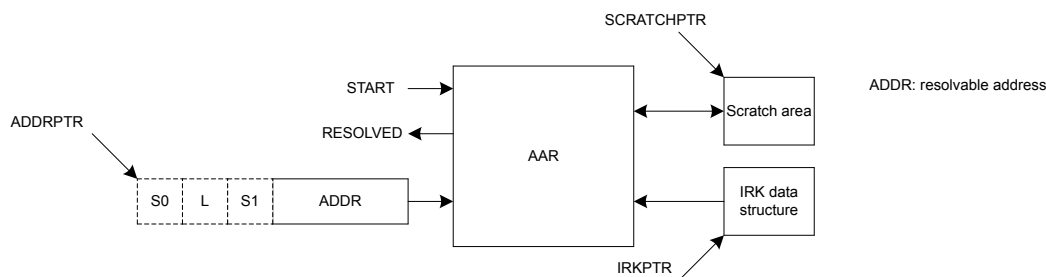

Figure 23: Address resolution with packet preloaded into RAM

6.2.3 Use case example for chaining RADIO packet reception with address resolution using AAR

The AAR may be started as soon as the 6 bytes required by the AAR have been received by the RADIO and stored in RAM. The ADDRPTR pointer must point to the start of packet.

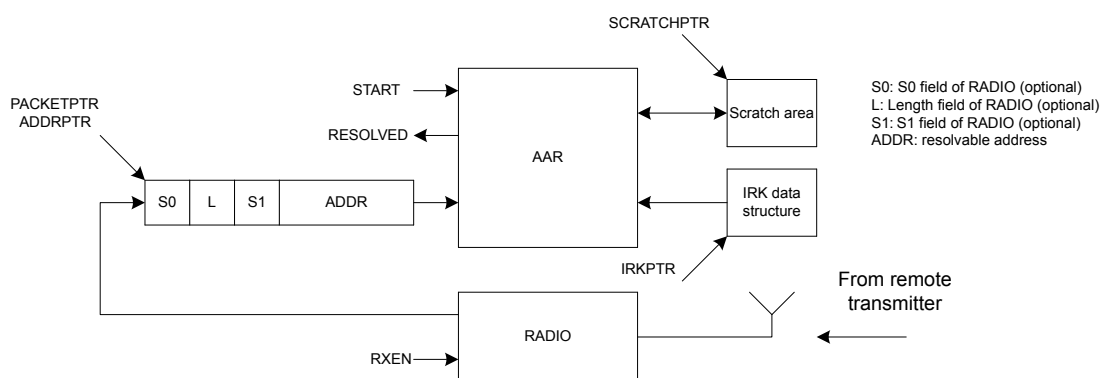

Figure 24: Address resolution with packet loaded into RAM by the RADIO

6.2.4 IRK data structure

The IRK data structure is located in RAM at the memory location specified by the IRKPTR register.

Property	Address offset	Description
IRK0	0	IRK number 0 (16 - byte)
IRK1	16	IRK number 1 (16 - byte)
..
IRK15	240	IRK number 15 (16 - byte)

Table 20: IRK data structure overview

6.2.5 Registers

Base address	Peripheral	Instance	Description	Configuration
0x4000F000	AAR	AAR	Accelerated address resolver	

Register	Offset	Description
TASKS_START	0x000	Start resolving addresses based on IRKs specified in the IRK data structure
TASKS_STOP	0x008	Stop resolving addresses
EVENTS_END	0x100	Address resolution procedure complete

Table 21: Instances

Register	Offset	Description
EVENTS_RESOLVED	0x104	Address resolved
EVENTS_NOTRESOLVED	0x108	Address not resolved
INTENSET	0x304	Enable interrupt
INTENCLR	0x308	Disable interrupt
STATUS	0x400	Resolution status
ENABLE	0x500	Enable AAR
NIRK	0x504	Number of IRKs
IRKPTR	0x508	Pointer to IRK data structure
ADDRPTR	0x510	Pointer to the resolvable address
SCRATCHPTR	0x514	Pointer to data area used for temporary storage

Table 22: Register overview

6.2.5.1 TASKS_START

Address offset: 0x000

Start resolving addresses based on IRKs specified in the IRK data structure

Bit number	31 30 29 28 27 26 25 24 23 22 21 20 19 18 17 16 15 14 13 12 11 10 9 8 7 6 5 4 3 2 1 0																															
ID																																A
Reset 0x00000000	0 0																															
ID	Acce	Field	Value ID	Value	Description																											
A	W	TASKS_START			Start resolving addresses based on IRKs specified in the IRK data structure																											
			Trigger	1	Trigger task																											

6.2.5.2 TASKS_STOP

Address offset: 0x008

Stop resolving addresses

Bit number	31 30 29 28 27 26 25 24 23 22 21 20 19 18 17 16 15 14 13 12 11 10 9 8 7 6 5 4 3 2 1 0																															
ID																																A
Reset 0x00000000	0 0																															
ID	Acce	Field	Value ID	Value	Description																											
A	W	TASKS_STOP			Stop resolving addresses																											
			Trigger	1	Trigger task																											

6.2.5.3 EVENTS_END

Address offset: 0x100

Address resolution procedure complete

Bit number	31 30 29 28 27 26 25 24 23 22 21 20 19 18 17 16 15 14 13 12 11 10 9 8 7 6 5 4 3 2 1 0																															
ID																																A
Reset 0x00000000	0 0																															
ID	Acce	Field	Value ID	Value	Description																											
A	RW	EVENTS_END			Address resolution procedure complete																											
			NotGenerated	0	Event not generated																											
			Generated	1	Event generated																											

6.2.5.4 EVENTS_RESOLVED

Address offset: 0x104

Address resolved

Bit number	31	30	29	28	27	26	25	24	23	22	21	20	19	18	17	16	15	14	13	12	11	10	9	8	7	6	5	4	3	2	1	0
ID																																A
Reset 0x00000000	0 0																															
ID	Acce Field	Value ID	Value	Description																												
A	RW	EVENTS_RESOLVED		Address resolved																												
		NotGenerated	0	Event not generated																												
		Generated	1	Event generated																												

6.2.5.5 EVENTS_NOTRESOLVED

Address offset: 0x108

Address not resolved

Bit number	31	30	29	28	27	26	25	24	23	22	21	20	19	18	17	16	15	14	13	12	11	10	9	8	7	6	5	4	3	2	1	0
ID																																A
Reset 0x00000000	0 0																															
ID	Acce Field	Value ID	Value	Description																												
A	RW	EVENTS_NOTRESOLVED		Address not resolved																												
		NotGenerated	0	Event not generated																												
		Generated	1	Event generated																												

6.2.5.6 INTENSET

Address offset: 0x304

Enable interrupt

Bit number	31	30	29	28	27	26	25	24	23	22	21	20	19	18	17	16	15	14	13	12	11	10	9	8	7	6	5	4	3	2	1	0
ID																																C B A
Reset 0x00000000	0 0																															
ID	Acce Field	Value ID	Value	Description																												
A	RW	END		Write '1' to enable interrupt for event END																												
		Set	1	Enable																												
		Disabled	0	Read: Disabled																												
		Enabled	1	Read: Enabled																												
B	RW	RESOLVED		Write '1' to enable interrupt for event RESOLVED																												
		Set	1	Enable																												
		Disabled	0	Read: Disabled																												
		Enabled	1	Read: Enabled																												
C	RW	NOTRESOLVED		Write '1' to enable interrupt for event NOTRESOLVED																												
		Set	1	Enable																												
		Disabled	0	Read: Disabled																												
		Enabled	1	Read: Enabled																												

6.2.5.7 INTENCLR

Address offset: 0x308

Disable interrupt

Bit number	31 30 29 28 27 26 25 24 23 22 21 20 19 18 17 16 15 14 13 12 11 10 9 8 7 6 5 4 3 2 1 0																																
ID																															C	B	A
Reset 0x00000000	0 0																																
ID	Acce	Field	Value ID	Value	Description																												
A	RW	END			Write '1' to disable interrupt for event END																												
			Clear	1	Disable																												
			Disabled	0	Read: Disabled																												
			Enabled	1	Read: Enabled																												
B	RW	RESOLVED			Write '1' to disable interrupt for event RESOLVED																												
			Clear	1	Disable																												
			Disabled	0	Read: Disabled																												
			Enabled	1	Read: Enabled																												
C	RW	NOTRESOLVED			Write '1' to disable interrupt for event NOTRESOLVED																												
			Clear	1	Disable																												
			Disabled	0	Read: Disabled																												
			Enabled	1	Read: Enabled																												

6.2.5.8 STATUS

Address offset: 0x400

Resolution status

Bit number	31 30 29 28 27 26 25 24 23 22 21 20 19 18 17 16 15 14 13 12 11 10 9 8 7 6 5 4 3 2 1 0																																	
ID																															A	A	A	A
Reset 0x00000000	0 0																																	
ID	Acce	Field	Value ID	Value	Description																													
A	R	STATUS		[0..15]	The IRK that was used last time an address was resolved																													

6.2.5.9 ENABLE

Address offset: 0x500

Enable AAR

Bit number	31 30 29 28 27 26 25 24 23 22 21 20 19 18 17 16 15 14 13 12 11 10 9 8 7 6 5 4 3 2 1 0																															
ID																															A	A
Reset 0x00000000	0 0																															
ID	Acce	Field	Value ID	Value	Description																											
A	RW	ENABLE			Enable or disable AAR																											
			Disabled	0	Disable																											
			Enabled	3	Enable																											

6.2.5.10 NIRK

Address offset: 0x504

Number of IRKs

Bit number	31 30 29 28 27 26 25 24 23 22 21 20 19 18 17 16 15 14 13 12 11 10 9 8 7 6 5 4 3 2 1 0																																	
ID																															A	A	A	A
Reset 0x00000001	0 1																																	
ID	Acce	Field	Value ID	Value	Description																													
A	RW	NIRK		[1..16]	Number of Identity root keys available in the IRK data structure																													

6.2.5.11 IRKPTR

Address offset: 0x508

Pointer to IRK data structure

Bit number	31	30	29	28	27	26	25	24	23	22	21	20	19	18	17	16	15	14	13	12	11	10	9	8	7	6	5	4	3	2	1	0
ID	A	A	A	A	A	A	A	A	A	A	A	A	A	A	A	A	A	A	A	A	A	A	A	A	A	A	A	A	A	A	A	A
Reset 0x00000000	0	0	0	0	0	0	0	0	0	0	0	0	0	0	0	0	0	0	0	0	0	0	0	0	0	0	0	0	0	0	0	0
ID	Acce	Field	Value ID	Value	Description																											
A	RW	IRKPTR			Pointer to the IRK data structure																											

6.2.5.12 ADDRPTR

Address offset: 0x510

Pointer to the resolvable address

Bit number	31	30	29	28	27	26	25	24	23	22	21	20	19	18	17	16	15	14	13	12	11	10	9	8	7	6	5	4	3	2	1	0
ID	A	A	A	A	A	A	A	A	A	A	A	A	A	A	A	A	A	A	A	A	A	A	A	A	A	A	A	A	A	A	A	
Reset 0x00000000	0	0	0	0	0	0	0	0	0	0	0	0	0	0	0	0	0	0	0	0	0	0	0	0	0	0	0	0	0	0	0	
ID	Acce	Field	Value ID	Value	Description																											
A	RW	ADDRPTR			Pointer to the resolvable address (6-bytes)																											

6.2.5.13 SCRATCHPTR

Address offset: 0x514

Pointer to data area used for temporary storage

Bit number	31	30	29	28	27	26	25	24	23	22	21	20	19	18	17	16	15	14	13	12	11	10	9	8	7	6	5	4	3	2	1	0
ID	A	A	A	A	A	A	A	A	A	A	A	A	A	A	A	A	A	A	A	A	A	A	A	A	A	A	A	A	A	A	A	
Reset 0x00000000	0	0	0	0	0	0	0	0	0	0	0	0	0	0	0	0	0	0	0	0	0	0	0	0	0	0	0	0	0	0	0	
ID	Acce	Field	Value ID	Value	Description																											
A	RW	SCRATCHPTR			Pointer to a scratch data area used for temporary storage during resolution. A space of minimum 3 bytes must be reserved.																											

6.2.6 Electrical specification

6.2.6.1 AAR Electrical Specification

Symbol	Description	Min.	Typ.	Max.	Units
t _{AAR}	Address resolution time per IRK. Total time for several IRKs is given as (1 μs + n * t _{AAR}), where n is the number of IRKs. (Given priority to the actual destination RAM block).	μs
t _{AAR,8}	Time for address resolution of 8 IRKs. (Given priority to the actual destination RAM block).		48		μs

6.3 BPROT — Block protection

The mechanism for protecting non-volatile memory can be used to prevent erroneous application code from erasing or writing to protected blocks.

Non-volatile memory can be protected from erases and writes depending on the settings in the CONFIG registers. One bit in a CONFIG register represents one protected block of 4 kB. There are multiple CONFIG registers to cover the whole range of the flash. [Protected regions of program memory](#) on page 84 illustrates how the CONFIG bits map to the program memory space.

Important: If an erase or write to a protected block is detected, the CPU will hard fault. If an ERASEALL operation is attempted from the CPU while any block is protected, it will be blocked and the CPU will hard fault.

On reset, all the protection bits are cleared. To ensure safe operation, the first task after reset must be to set the protection bits. The only way of clearing protection bits is by resetting the device from any reset source.

The protection mechanism is turned off when in debug mode (when a debugger is connected) and the DISABLEINDEBUG register is set to disabled.

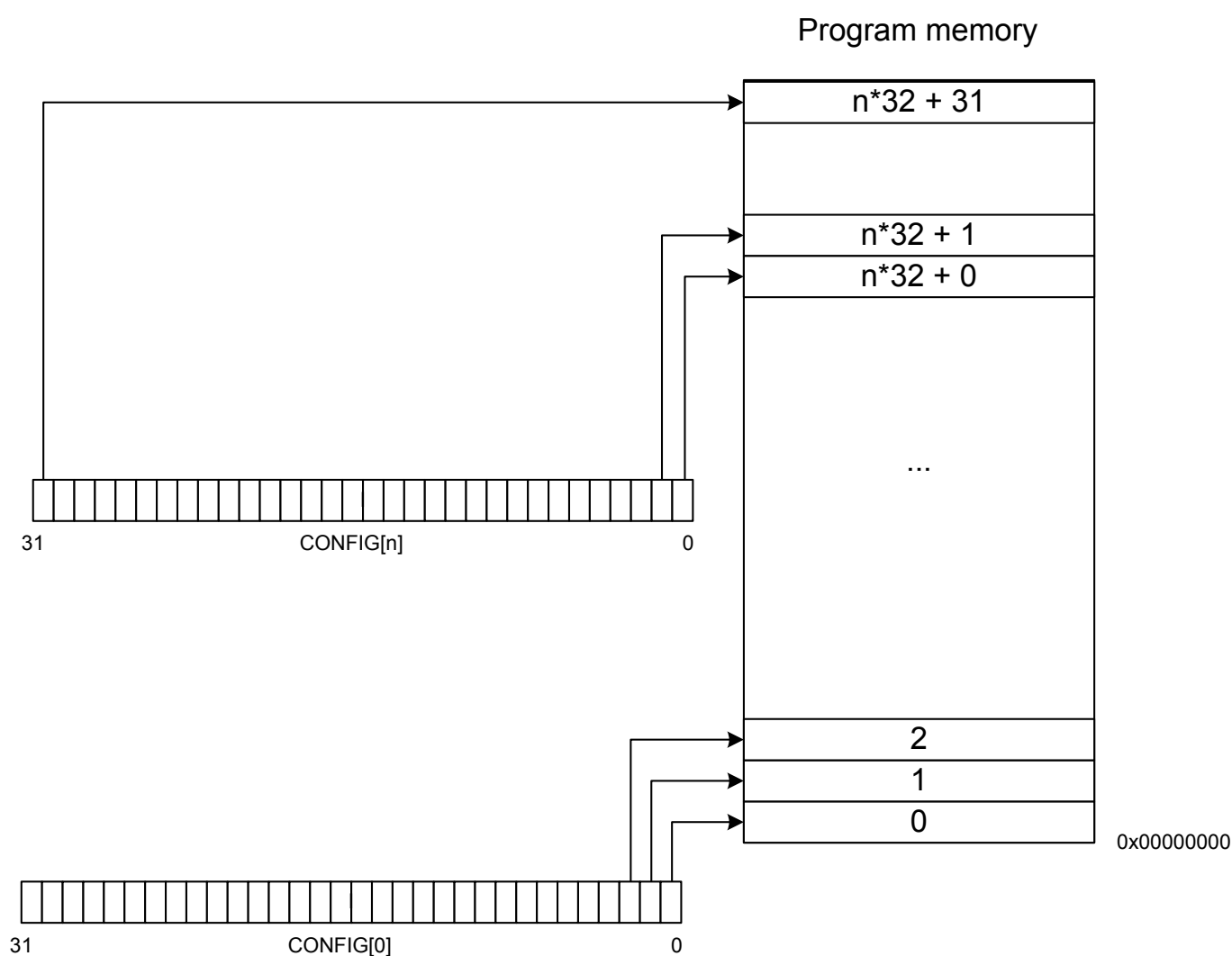

Figure 25: Protected regions of program memory

6.3.1 Registers

Base address	Peripheral	Instance	Description	Configuration
0x40000000	BPROT	BPROT	Block protect	

Table 23: Instances

Register	Offset	Description	Configuration
CONFIG0	0x600	Block protect configuration register 0	
CONFIG1	0x604	Block protect configuration register 1	
DISABLEINDEBUG	0x608	Disable protection mechanism in debug mode	
UNUSED0	0x60C		Reserved

Table 24: Register overview

6.3.1.1 CONFIG0

Address offset: 0x600

Block protect configuration register 0

Bit number	31 30 29 28 27 26 25 24 23 22 21 20 19 18 17 16 15 14 13 12 11 10 9 8 7 6 5 4 3 2 1 0																														
ID	f e d c b a Z Y X W V U T S R Q P O N M L K J I H G F E D C B A																														
Reset 0x00000000	0 0																														
ID	Acce	Field	Value ID	Value	Description																										
A-f	RW	REGION[i] (i=0..31)			Enable protection for region i. Write '0' has no effect.																										
			Disabled	0	Protection disabled																										
			Enabled	1	Protection enabled																										

6.3.1.2 CONFIG1

Address offset: 0x604

Block protect configuration register 1

Bit number	31 30 29 28 27 26 25 24 23 22 21 20 19 18 17 16 15 14 13 12 11 10 9 8 7 6 5 4 3 2 1 0																														
ID	P O N M L K J I H G F E D C B A																														
Reset 0x00000000	0 0																														
ID	Acce	Field	Value ID	Value	Description																										
A-P	RW	REGION[i+32] (i=0..15)			Enable protection for region i+32. Write '0' has no effect.																										
			Disabled	0	Protection disabled																										
			Enabled	1	Protection enabled																										

6.3.1.3 DISABLEINDEBUG

Address offset: 0x608

Disable protection mechanism in debug mode

Bit number	31	30	29	28	27	26	25	24	23	22	21	20	19	18	17	16	15	14	13	12	11	10	9	8	7	6	5	4	3	2	1	0
ID	A																															
Reset 0x00000001	0 1																															
ID	Acce Field	Value ID	Value	Description																												
A	RW	DISABLEINDEBUG		Disable the protection mechanism for NVM regions while in debug mode. This register will only disable the protection mechanism if the device is in debug mode.																												
		Disabled	1	Disabled in debug																												
		Enabled	0	Enabled in debug																												

6.4 CCM — AES CCM mode encryption

Cipher block chaining - message authentication code (CCM) mode is an authenticated encryption algorithm designed to provide both authentication and confidentiality during data transfer. CCM combines counter mode encryption and CBC-MAC authentication. The CCM terminology "Message authentication code (MAC)" is called the "Message integrity check (MIC)" in *Bluetooth* terminology and also in this document.

The CCM block generates an encrypted keystream that is applied to input data using the XOR operation and generates the 4 byte MIC field in one operation. The CCM and radio can be configured to work synchronously. The CCM will encrypt in time for transmission and decrypt after receiving bytes into memory from the radio. All operations can complete within the packet RX or TX time. CCM on this device is implemented according to *Bluetooth* requirements and the algorithm as defined in IETF [RFC3610](#), and depends on the AES-128 block cipher. A description of the CCM algorithm can also be found in [NIST Special Publication 800-38C](#). The *Bluetooth* specification describes the configuration of counter mode blocks and encryption blocks to implement compliant encryption for BLE.

The CCM block uses EasyDMA to load key, counter mode blocks (including the nonce required), and to read/write plain text and cipher text.

The AES CCM supports three operations: key-stream generation, packet encryption, and packet decryption. All these operations are done in compliance with the *Bluetooth* specification.¹³

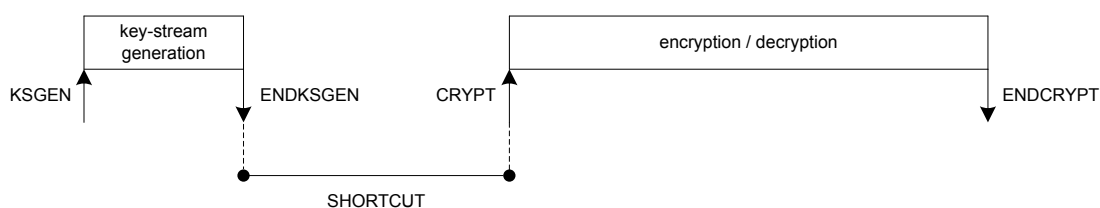

Figure 26: Key-stream generation followed by encryption or decryption. The shortcut is optional.

6.4.1 Key-steam generation

A new key-stream needs to be generated before a new packet encryption or packet decryption operation can be started.

A key-stream is generated by triggering the KSGEN task and an ENDKSGEN event will be generated when the key-stream has been generated.

Key-stream generation, packet encryption, and packet decryption operations utilize the configuration specified in the data structure pointed to by [CNFPTR](#) on page 96. It is necessary to configure this pointer and its underlying data structure, and the [MODE](#) on page 95 register before the KSGEN task is triggered.

¹³ *Bluetooth* AES CCM 128 bit block encryption, see *Bluetooth* Core specification Version 4.0.

The key-stream will be stored in the AES CCM's temporary memory area, specified by the [SCRATCHPTR](#) on page 96, where it will be used in subsequent encryption and decryption operations.

For default length packets (MODE.LENGTH = Default) the size of the generated key-stream is 27 bytes. When using extended length packets (MODE.LENGTH = Extended) the [MAXPACKETSIZE](#) on page 97 register specifies the length of the key-stream to be generated. The length of the generated key-stream must be greater or equal to the length of the subsequent packet payload to be encrypted or decrypted. The maximum length of the key-stream in extended mode is 251 bytes, which means that the maximum packet payload size is 251.

If a shortcut is used between ENDKSGEN event and CRYPT task, the [INPTR](#) on page 96 pointer and the [OUTPTR](#) on page 96 pointers must also be configured before the KSGEN task is triggered.

6.4.2 Encryption

During packet encryption, the AES CCM will read the unencrypted packet located in RAM at the address specified in the INPTR pointer, encrypt the packet and append a four byte long Message Integrity Check (MIC) field to the packet.

Encryption is started by triggering the CRYPT task with the [MODE](#) on page 95 register set to ENCRYPTION. An ENDCRYPT event will be generated when packet encryption is completed

The AES CCM will also modify the length field of the packet to adjust for the appended MIC field, that is, add four bytes to the length, and store the resulting packet back into RAM at the address specified in the [OUTPTR](#) on page 96 pointer, see [Encryption](#) on page 87.

Empty packets (length field is set to 0) will not be encrypted but instead moved unmodified through the AES CCM.

The CCM supports different widths of the LENGTH field in the data structure for encrypted packets. This is configured in the [MODE](#) on page 95 register.

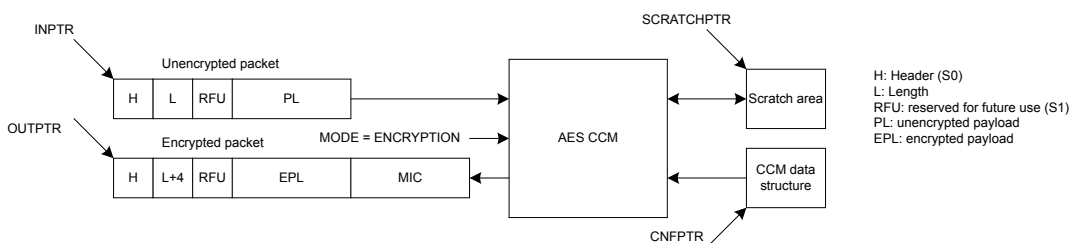

Figure 27: Encryption

6.4.3 Decryption

During packet decryption, the AES CCM will read the encrypted packet located in RAM at the address specified in the INPTR pointer, decrypt the packet, authenticate the packet's MIC field and generate the appropriate MIC status.

Decryption is started by triggering the CRYPT task with the [MODE](#) on page 95 register set to DECRYPTION. An ENDCRYPT event will be generated when packet decryption is completed

The AES CCM will also modify the length field of the packet to adjust for the MIC field, that is, subtract four bytes from the length, and then store the decrypted packet into RAM at the address pointed to by the OUTPTR pointer, see [Decryption](#) on page 88.

The CCM is only able to decrypt packet payloads that are at least 5 bytes long, that is, 1 byte or more encrypted payload (EPL) and 4 bytes of MIC. The CCM will therefore generate a MIC error for packets where the length field is set to 1, 2, 3 or 4.

Empty packets (length field is set to 0) will not be decrypted but instead moved unmodified through the AES CCM, these packets will always pass the MIC check.

The CCM supports different widths of the LENGTH field in the data structure for decrypted packets. This is configured in the **MODE** on page 95 register.

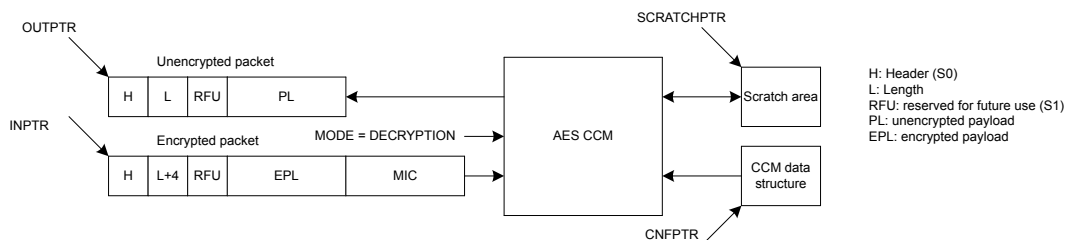

Figure 28: Decryption

6.4.4 AES CCM and RADIO concurrent operation

The CCM module is able to encrypt/decrypt data synchronously to data being transmitted or received on the radio.

In order for the CCM module to run synchronously with the radio, the data rate setting in the **MODE** on page 95 register needs to match the radio data rate. The settings in this register apply whenever either the KSGEN or CRYPT tasks are triggered.

The data rate setting of the **MODE** on page 95 register can also be overridden on-the-fly during an ongoing encrypt/decrypt operation by the contents of the **RATEOVERRIDE** on page 97 register. The data rate setting in this register applies whenever the RATEOVERRIDE task is triggered. This feature can be useful in cases where the radio data rate is changed during an ongoing packet transaction.

6.4.5 Encrypting packets on-the-fly in radio transmit mode

When the AES CCM is encrypting a packet on-the-fly at the same time as the radio is transmitting it, the radio must read the encrypted packet from the same memory location as the AES CCM is writing to.

The **OUTPTR** on page 96 pointer in the AES CCM must therefore point to the same memory location as the **PACKETPTR** pointer in the radio, see [Configuration of on-the-fly encryption](#) on page 88.

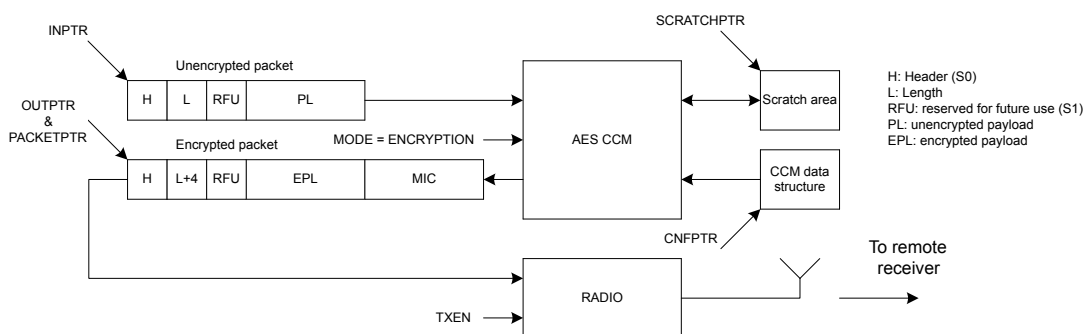

Figure 29: Configuration of on-the-fly encryption

In order to match the RADIO's timing, the KSGEN task must be triggered early enough to allow the key-stream generation to complete before the encryption of the packet shall start.

For short packets (**MODE.LENGTH** = Default) the KSGEN task must be triggered no later than when the **START** task in the RADIO is triggered. In addition the shortcut between the **ENDKSGEN** event and the **CRYPT** task must be enabled. This use-case is illustrated in [On-the-fly encryption of short packets \(MODE.LENGTH = Default\) using a PPI connection](#) on page 89 using a PPI connection between the **READY** event in the RADIO and the **KSGEN** task in the AES CCM.

For long packets (**MODE.LENGTH** = Extended) the key-stream generation will need to be started even earlier, for example at the time when the **TXEN** task in the RADIO is triggered.

Important: Refer to [Timing specification](#) on page 98 for information about the time needed for generating a key-stream.

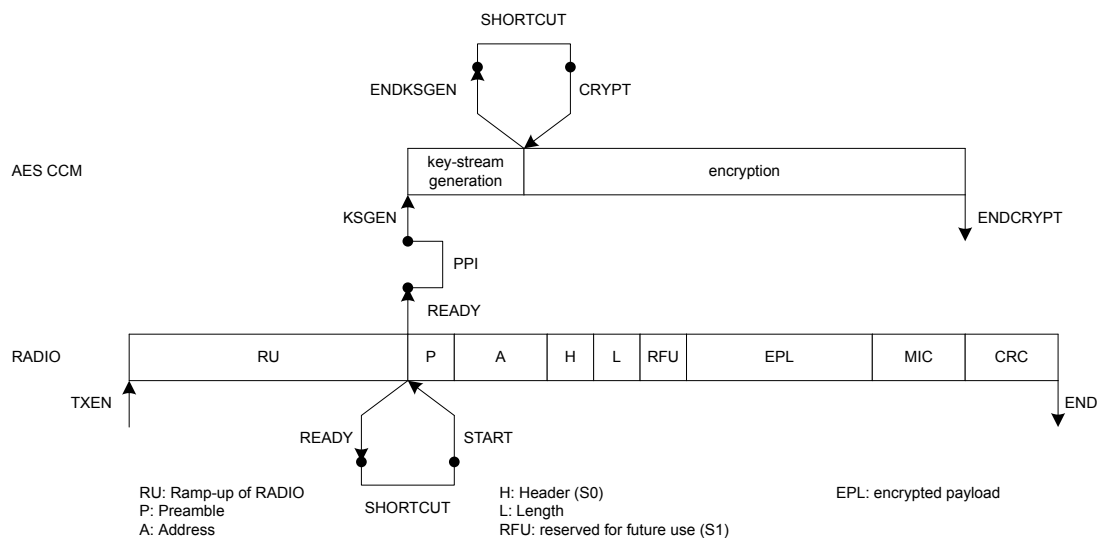

Figure 30: On-the-fly encryption of short packets (MODE.LENGTH = Default) using a PPI connection

6.4.6 Decrypting packets on-the-fly in radio receive mode

When the AES CCM is decrypting a packet on-the-fly at the same time as the RADIO is receiving it, the AES CCM must read the encrypted packet from the same memory location as the RADIO is writing to.

The [INPTR](#) on page 96 pointer in the AES CCM must therefore point to the same memory location as the [PACKETPTR](#) pointer in the RADIO, see [Configuration of on-the-fly decryption](#) on page 89.

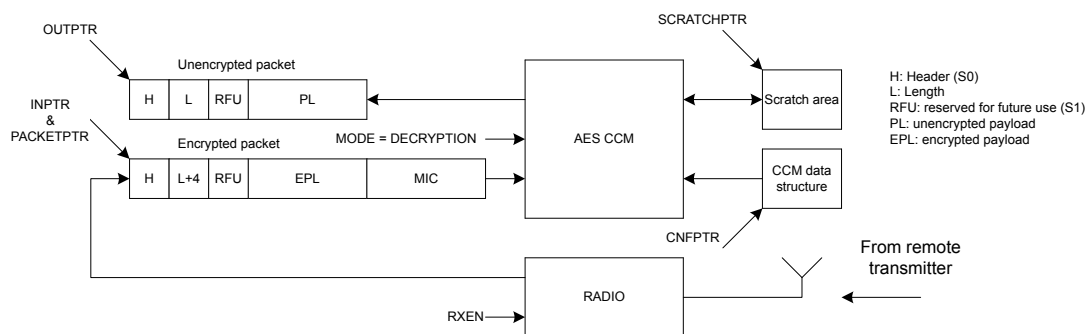

Figure 31: Configuration of on-the-fly decryption

In order to match the RADIO's timing, the KSGEN task must be triggered early enough to allow the key-stream generation to complete before the decryption of the packet shall start.

For short packets (MODE.LENGTH = Default) the KSGEN task must be triggered no later than when the START task in the RADIO is triggered. In addition, the CRYPT task must be triggered no earlier than when the ADDRESS event is generated by the RADIO.

If the CRYPT task is triggered exactly at the same time as the ADDRESS event is generated by the RADIO, the AES CCM will guarantee that the decryption is completed no later than when the END event in the RADIO is generated.

This use-case is illustrated in [On-the-fly decryption of short packets \(MODE.LENGTH = Default\) using a PPI connection](#) on page 90 using a PPI connection between the ADDRESS event in the RADIO and the CRYPT task in the AES CCM. The KSGEN task is triggered from the READY event in the RADIO through a PPI connection.

For long packets (MODE.LENGTH = Extended) the key-stream generation will need to be started even earlier, for example at the time when the RXEN task in the RADIO is triggered.

Important: Refer to [Timing specification](#) on page 98 for information about the time needed for generating a key-stream.

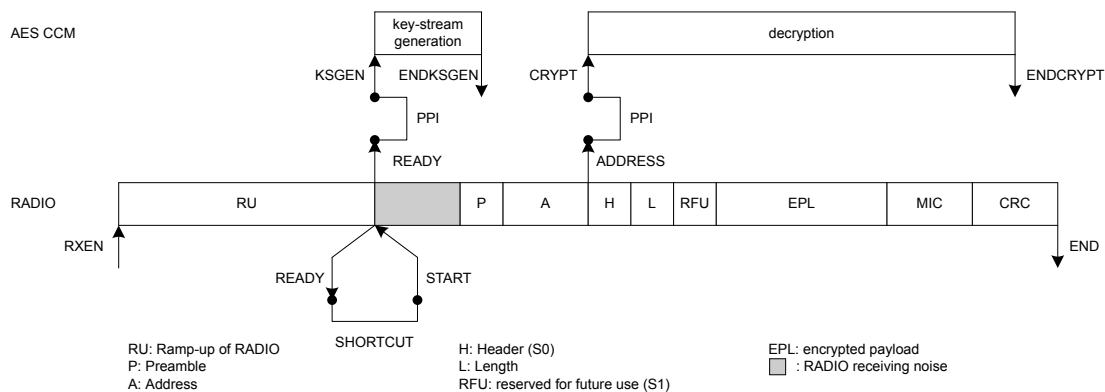

Figure 32: On-the-fly decryption of short packets (MODE.LENGTH = Default) using a PPI connection

6.4.7 CCM data structure

The CCM data structure is located in Data RAM at the memory location specified by the CNFPTR pointer register.

Property	Address offset	Description
KEY	0	16 byte AES key
PKTCTR	16	Octet0 (LSO) of packet counter
	17	Octet1 of packet counter
	18	Octet2 of packet counter
	19	Octet3 of packet counter
	20	Bit 6 – Bit 0: Octet4 (7 most significant bits of packet counter, with Bit 6 being the most significant bit) Bit7: Ignored
	21	Ignored
	22	Ignored
	23	Ignored
	24	Bit 0: Direction bit Bit 7 – Bit 1: Zero padded
IV	25	8 byte initialization vector (IV) Octet0 (LSO) of IV, Octet1 of IV, ... , Octet7 (MSO) of IV

Table 25: CCM data structure overview

The NONCE vector (as specified by the *Bluetooth* Core Specification) will be generated by hardware based on the information specified in the CCM data structure from [CCM data structure overview](#) on page 90 .

Property	Address offset	Description
HEADER	0	Packet Header
LENGTH	1	Number of bytes in unencrypted payload
RFU	2	Reserved Future Use
PAYLOAD	3	Unencrypted payload

Table 26: Data structure for unencrypted packet

Property	Address offset	Description
HEADER	0	Packet Header
LENGTH	1	Number of bytes in encrypted payload including length of MIC Important: LENGTH will be 0 for empty packets since the MIC is not added to empty packets
RFU	2	Reserved Future Use
PAYLOAD	3	Encrypted payload
MIC	3 + payload length	ENCRYPT: 4 bytes encrypted MIC Important: MIC is not added to empty packets

Table 27: Data structure for encrypted packet

6.4.8 EasyDMA and ERROR event

The CCM implements an EasyDMA mechanism for reading and writing to the RAM.

In cases where the CPU and other EasyDMA enabled peripherals are accessing the same RAM block at the same time, a high level of bus collisions may cause too slow operation for correct on the fly encryption. In this case the ERROR event will be generated.

The EasyDMA will have finished accessing the RAM when the ENDKSGEN and ENDCRYPT events are generated.

If the CNFPTR, SCRATCHPTR, INPTR and the OUTPTR are not pointing to the Data RAM region, an EasyDMA transfer may result in a HardFault or RAM corruption. See [Memory](#) on page 17 for more information about the different memory regions.

6.4.9 Registers

Base address	Peripheral	Instance	Description	Configuration
0x4000F000	CCM	CCM	AES CCM mode encryption	

Table 28: Instances

Register	Offset	Description	
TASKS_KSGEN	0x000	Start generation of key-stream. This operation will stop by itself when completed.	
TASKS_CRYPT	0x004	Start encryption/decryption. This operation will stop by itself when completed.	
TASKS_STOP	0x008	Stop encryption/decryption	
TASKS_RATEOVERRIDE	0x00C	Override DATARATE setting in MODE register with the contents of the RATEOVERRIDE register for any ongoing encryption/decryption	
EVENTS_ENDKSGEN	0x100	Key-stream generation complete	
EVENTS_ENDCRYPT	0x104	Encrypt/decrypt complete	
EVENTS_ERROR	0x108	CCM error event	Deprecated
SHORTS	0x200	Shortcuts between local events and tasks	
INTENSET	0x304	Enable interrupt	
INTENCLR	0x308	Disable interrupt	
MICSTATUS	0x400	MIC check result	
ENABLE	0x500	Enable	
MODE	0x504	Operation mode	
CNFPTR	0x508	Pointer to data structure holding AES key and NONCE vector	
INPTR	0x50C	Input pointer	
OUTPTR	0x510	Output pointer	
SCRATCHPTR	0x514	Pointer to data area used for temporary storage	

Register	Offset	Description
MAXPACKETSIZE	0x518	Length of key-stream generated when MODE.LENGTH = Extended.
RATEOVERRIDE	0x51C	Data rate override setting.

Table 29: Register overview

6.4.9.1 TASKS_KSGEN

Address offset: 0x000

Start generation of key-stream. This operation will stop by itself when completed.

Bit number	31 30 29 28 27 26 25 24 23 22 21 20 19 18 17 16 15 14 13 12 11 10 9 8 7 6 5 4 3 2 1 0																														
ID	A																														
Reset 0x00000000	0 0																														
ID	Acce Field	Value ID	Value	Description																											
A	W TASKS_KSGEN			Start generation of key-stream. This operation will stop by itself when completed.																											
		Trigger	1	Trigger task																											

6.4.9.2 TASKS_CRYPT

Address offset: 0x004

Start encryption/decryption. This operation will stop by itself when completed.

Bit number	31 30 29 28 27 26 25 24 23 22 21 20 19 18 17 16 15 14 13 12 11 10 9 8 7 6 5 4 3 2 1 0																														
ID	A																														
Reset 0x00000000	0 0																														
ID	Acce Field	Value ID	Value	Description																											
A	W TASKS_CRYPT			Start encryption/decryption. This operation will stop by itself when completed.																											
		Trigger	1	Trigger task																											

6.4.9.3 TASKS_STOP

Address offset: 0x008

Stop encryption/decryption

Bit number	31 30 29 28 27 26 25 24 23 22 21 20 19 18 17 16 15 14 13 12 11 10 9 8 7 6 5 4 3 2 1 0																														
ID	A																														
Reset 0x00000000	0 0																														
ID	Acce Field	Value ID	Value	Description																											
A	W TASKS_STOP			Stop encryption/decryption																											
		Trigger	1	Trigger task																											

6.4.9.4 TASKS_RATEOVERRIDE

Address offset: 0x00C

Override DATARATE setting in MODE register with the contents of the RATEOVERRIDE register for any ongoing encryption/decryption

Bit number	31	30	29	28	27	26	25	24	23	22	21	20	19	18	17	16	15	14	13	12	11	10	9	8	7	6	5	4	3	2	1	0	
ID																																A	
Reset	0x00000000																																
0	0	0	0	0	0	0	0	0	0	0	0	0	0	0	0	0	0	0	0	0	0	0	0	0	0	0	0	0	0	0	0	0	0
ID	Acce	Field	Value	ID	Value	Description																											
A	W	TASKS_RATEOVERRIDE				Override DATARATE setting in MODE register with the contents of the RATEOVERRIDE register for any ongoing encryption/decryption																											
			Trigger	1		Trigger task																											

6.4.9.5 EVENTS_ENDKSGEN

Address offset: 0x100

Key-stream generation complete

Bit number	31	30	29	28	27	26	25	24	23	22	21	20	19	18	17	16	15	14	13	12	11	10	9	8	7	6	5	4	3	2	1	0
ID																																A
Reset	0x00000000																															
0	0	0	0	0	0	0	0	0	0	0	0	0	0	0	0	0	0	0	0	0	0	0	0	0	0	0	0	0	0	0	0	0
ID	Acce	Field	Value	ID	Value	Description																										
A	RW	EVENTS_ENDKSGEN				Key-stream generation complete																										
			NotGenerated	0		Event not generated																										
			Generated	1		Event generated																										

6.4.9.6 EVENTS_ENDCRYPT

Address offset: 0x104

Encrypt/decrypt complete

Bit number	31	30	29	28	27	26	25	24	23	22	21	20	19	18	17	16	15	14	13	12	11	10	9	8	7	6	5	4	3	2	1	0
ID																																A
Reset	0x00000000																															
0	0	0	0	0	0	0	0	0	0	0	0	0	0	0	0	0	0	0	0	0	0	0	0	0	0	0	0	0	0	0	0	0
ID	Acce	Field	Value	ID	Value	Description																										
A	RW	EVENTS_ENDCRYPT				Encrypt/decrypt complete																										
			NotGenerated	0		Event not generated																										
			Generated	1		Event generated																										

6.4.9.7 EVENTS_ERROR (Deprecated)

Address offset: 0x108

CCM error event

Bit number	31	30	29	28	27	26	25	24	23	22	21	20	19	18	17	16	15	14	13	12	11	10	9	8	7	6	5	4	3	2	1	0
ID																																A
Reset	0x00000000																															
0	0	0	0	0	0	0	0	0	0	0	0	0	0	0	0	0	0	0	0	0	0	0	0	0	0	0	0	0	0	0	0	0
ID	Acce	Field	Value	ID	Value	Description																										
A	RW	EVENTS_ERROR				CCM error event																										
			NotGenerated	0		Event not generated																										
			Generated	1		Event generated																										

6.4.9.8 SHORTS

Address offset: 0x200

Shortcuts between local events and tasks

Bit number	31	30	29	28	27	26	25	24	23	22	21	20	19	18	17	16	15	14	13	12	11	10	9	8	7	6	5	4	3	2	1	0
ID																																A
Reset 0x00000000	0 0																															
ID	Acce Field	Value ID	Value	Description																												
A	RW ENDKSGEN_CRYPT	Disabled	0	Disable shortcut																												
		Enabled	1	Enable shortcut																												

6.4.9.9 INTENSET

Address offset: 0x304

Enable interrupt

Bit number	31	30	29	28	27	26	25	24	23	22	21	20	19	18	17	16	15	14	13	12	11	10	9	8	7	6	5	4	3	2	1	0
ID																																C B A
Reset 0x00000000	0 0																															
ID	Acce Field	Value ID	Value	Description																												
A	RW ENDKSGEN	Set	1	Write '1' to enable interrupt for event ENDKSGEN																												
		Disabled	0	Enable																												
		Enabled	1	Read: Disabled																												
B	RW ENDCRYPT	Set	1	Write '1' to enable interrupt for event ENDCRYPT																												
		Disabled	0	Enable																												
		Enabled	1	Read: Disabled																												
C	RW ERROR	Set	1	Write '1' to enable interrupt for event ERROR																												
		Disabled	0	Enable																												
		Enabled	1	Read: Disabled																												

6.4.9.10 INTENCLR

Address offset: 0x308

Disable interrupt

Bit number	31	30	29	28	27	26	25	24	23	22	21	20	19	18	17	16	15	14	13	12	11	10	9	8	7	6	5	4	3	2	1	0
ID																																C B A
Reset 0x00000000	0 0																															
ID	Acce Field	Value ID	Value	Description																												
A	RW ENDKSGEN	Clear	1	Write '1' to disable interrupt for event ENDKSGEN																												
		Disabled	0	Disable																												
		Enabled	1	Read: Disabled																												
B	RW ENDCRYPT	Clear	1	Write '1' to disable interrupt for event ENDCRYPT																												
		Disabled	0	Disable																												
		Enabled	1	Read: Disabled																												
C	RW ERROR	Clear	1	Write '1' to disable interrupt for event ERROR																												
		Disabled	0	Disable																												
		Enabled	1	Read: Disabled																												

6.4.9.11 MICSTATUS

Address offset: 0x400

MIC check result

Bit number	31	30	29	28	27	26	25	24	23	22	21	20	19	18	17	16	15	14	13	12	11	10	9	8	7	6	5	4	3	2	1	0
ID																																A
Reset 0x00000000	0 0																															
ID	Acce	Field	Value ID	Value	Description																											
A	R	MICSTATUS			The result of the MIC check performed during the previous decryption operation																											
			CheckFailed	0	MIC check failed																											
			CheckPassed	1	MIC check passed																											

6.4.9.12 ENABLE

Address offset: 0x500

Enable

Bit number	31	30	29	28	27	26	25	24	23	22	21	20	19	18	17	16	15	14	13	12	11	10	9	8	7	6	5	4	3	2	1	0
ID																																A A
Reset 0x00000000	0 0																															
ID	Acce	Field	Value ID	Value	Description																											
A	RW	ENABLE			Enable or disable CCM																											
			Disabled	0	Disable																											
			Enabled	2	Enable																											

6.4.9.13 MODE

Address offset: 0x504

Operation mode

Bit number	31	30	29	28	27	26	25	24	23	22	21	20	19	18	17	16	15	14	13	12	11	10	9	8	7	6	5	4	3	2	1	0	
ID											C											B B											A
Reset 0x00000001	0 1																																
ID	Acce	Field	Value ID	Value	Description																												
A	RW	MODE			The mode of operation to be used. The settings in this register apply whenever either the KSGEN or CRYPT tasks are triggered.																												
			Encryption	0	AES CCM packet encryption mode																												
			Decryption	1	AES CCM packet decryption mode																												
B	RW	DATARATE			Radio data rate that the CCM shall run synchronous with																												
			1Mbit	0	1 Mbps																												
			2Mbit	1	2 Mbps																												
			125Kbps	2	125 Kbps																												
			500Kbps	3	500 Kbps																												
C	RW	LENGTH			Packet length configuration																												
			Default	0	Default length. Effective length of LENGTH field in encrypted/decrypted packet is 5 bits. A key-stream for packet payloads up to 27 bytes will be generated.																												

Bit number	31 30 29 28 27 26 25 24 23 22 21 20 19 18 17 16 15 14 13 12 11 10 9 8 7 6 5 4 3 2 1 0																																
ID	C																B B																A
Reset	0x00000001																																
ID	Acce Field	Value ID	Value	Description																													
		Extended	1	Extended length. Effective length of LENGTH field in encrypted/decrypted packet is 8 bits. A key-stream for packet payloads up to MAXPACKETSIZE bytes will be generated.																													

6.4.9.14 CNFPTR

Address offset: 0x508

Pointer to data structure holding AES key and NONCE vector

Bit number	31 30 29 28 27 26 25 24 23 22 21 20 19 18 17 16 15 14 13 12 11 10 9 8 7 6 5 4 3 2 1 0																															
ID	A A																															
Reset	0x00000000																															
ID	Acce Field	Value ID	Value	Description																												
A	RW	CNFPTR		Pointer to the data structure holding the AES key and the CCM NONCE vector (see Table 1 CCM data structure overview)																												

6.4.9.15 INPTR

Address offset: 0x50C

Input pointer

Bit number	31 30 29 28 27 26 25 24 23 22 21 20 19 18 17 16 15 14 13 12 11 10 9 8 7 6 5 4 3 2 1 0																															
ID	A A																															
Reset	0x00000000																															
ID	Acce Field	Value ID	Value	Description																												
A	RW	INPTR		Input pointer																												

6.4.9.16 OUTPTR

Address offset: 0x510

Output pointer

Bit number	31 30 29 28 27 26 25 24 23 22 21 20 19 18 17 16 15 14 13 12 11 10 9 8 7 6 5 4 3 2 1 0																															
ID	A A																															
Reset	0x00000000																															
ID	Acce Field	Value ID	Value	Description																												
A	RW	OUTPTR		Output pointer																												

6.4.9.17 SCRATCHPTR

Address offset: 0x514

Pointer to data area used for temporary storage

Bit number	31	30	29	28	27	26	25	24	23	22	21	20	19	18	17	16	15	14	13	12	11	10	9	8	7	6	5	4	3	2	1	0	
ID	A	A	A	A	A	A	A	A	A	A	A	A	A	A	A	A	A	A	A	A	A	A	A	A	A	A	A	A	A	A	A	A	A
Reset 0x00000000	0	0	0	0	0	0	0	0	0	0	0	0	0	0	0	0	0	0	0	0	0	0	0	0	0	0	0	0	0	0	0	0	

ID	Acce Field	Value ID	Value	Description
A	RW	SCRATCHPTR		<p>Pointer to a scratch data area used for temporary storage during key-stream generation, MIC generation and encryption/decryption.</p> <p>The scratch area is used for temporary storage of data during key-stream generation and encryption.</p> <p>When MODE.LENGTH = Default, a space of 43 bytes is required for this temporary storage. MODE.LENGTH = Extended (16 + MAXPACKETSIZE) bytes of storage is required.</p>

6.4.9.18 MAXPACKETSIZE

Address offset: 0x518

Length of key-stream generated when MODE.LENGTH = Extended.

Bit number	31	30	29	28	27	26	25	24	23	22	21	20	19	18	17	16	15	14	13	12	11	10	9	8	7	6	5	4	3	2	1	0
ID																										A	A	A	A	A	A	A
Reset 0x000000FB	0	0	0	0	0	0	0	0	0	0	0	0	0	0	0	0	0	0	0	0	0	0	0	0	1	1	1	1	1	0	1	1

ID	Acce Field	Value ID	Value	Description
A	RW	MAXPACKETSIZE	[0x001B..0x00FB]	<p>Length of key-stream generated when MODE.LENGTH = Extended. This value must be greater or equal to the subsequent packet payload to be encrypted/decrypted.</p>

6.4.9.19 RATEOVERRIDE

Address offset: 0x51C

Data rate override setting.

Override value to be used instead of the setting of MODE.DATARATE. This override value applies when the RATEOVERRIDE task is triggered.

Bit number	31	30	29	28	27	26	25	24	23	22	21	20	19	18	17	16	15	14	13	12	11	10	9	8	7	6	5	4	3	2	1	0	
ID																																A	A
Reset 0x00000000	0	0	0	0	0	0	0	0	0	0	0	0	0	0	0	0	0	0	0	0	0	0	0	0	0	0	0	0	0	0	0	0	

ID	Acce Field	Value ID	Value	Description
A	RW	RATEOVERRIDE		Data rate override setting.
		1Mbit	0	1 Mbps
		2Mbit	1	2 Mbps
		125Kbps	2	125 Kbps
		500Kbps	3	500 Kbps

6.4.10 Electrical specification

6.4.10.1 Timing specification

Symbol	Description	Min.	Typ.	Max.	Units
t_{gen}	Time needed for key-stream generation (given priority access to destination RAM block).	μs

6.5 COMP — Comparator

The comparator (COMP) compares an input voltage (VIN+) against a second input voltage (VIN-). VIN+ can be derived either from an analog input pin (AIN0-AIN6) or VDD/2. VIN- can be derived from multiple sources depending on the operation mode of the comparator.

Main features of the comparator are:

- Input range from 0 V to VDD
- Single-ended mode
 - Fully flexible hysteresis using a 64-level reference ladder
- Differential mode
 - Configurable hysteresis
- Reference inputs (VREF):
 - VDD
 - External reference from AIN0 to AIN7 (between 0 V and VDD)
 - Internal references 1.2 V, 1.8 V and 2.4 V
- Three speed/power consumption modes: low-power, normal and high-speed
- Event generation on output changes
 - UP event on VIN- > VIN+
 - DOWN event on VIN- < VIN+
 - CROSS event on VIN+ and VIN- crossing
 - READY event on core and internal reference (if used) ready

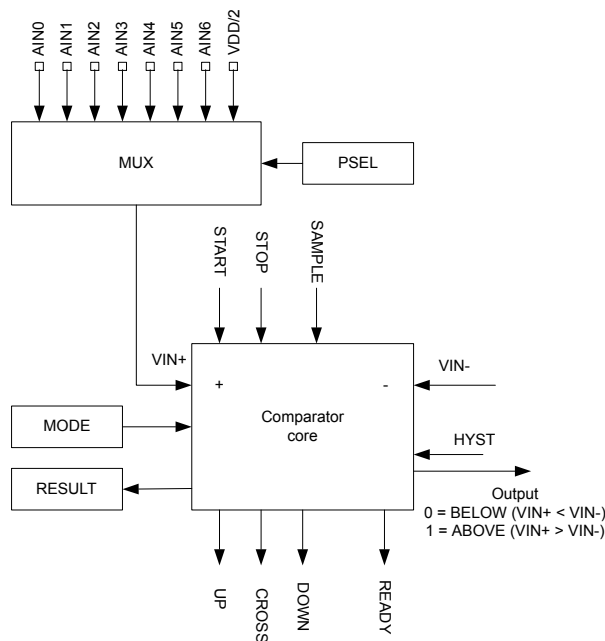

Figure 33: Comparator overview

Once enabled (using the [ENABLE](#) register), the comparator is started by triggering the START task and stopped by triggering the STOP task. After a start-up time of $t_{\text{COMP,START}}$, the comparator will generate a READY event to indicate that it is ready for use and that its output is correct. When the COMP module is started, events will be generated every time VIN+ crosses VIN-.

Operation modes

The comparator can be configured to operate in two main operation modes, differential mode and single-ended mode. See the [MODE](#) register for more information. In both operation modes, the comparator can operate in different speed and power consumption modes (low-power, normal and high-speed). High-speed mode will consume more power compared to low-power mode, and low-power mode will result in slower response time compared to high-speed mode.

Use the [PSEL](#) register to select any of the AIN0-AIN6 pins (or VDD/2) as VIN+ input, regardless of the operation mode selected for the comparator. The source of VIN- depends on which operation mode is used:

- Differential mode: Derived directly from AIN0 to AIN7
- Single-ended mode: Derived from VREF. VREF can be derived from VDD, AIN0-AIN7 or internal 1.2 V, 1.8 V and 2.4 V references.

The selected analog pins will be acquired by the comparator once it is enabled.

An optional hysteresis on VIN+ and VIN- can be enabled when the module is used in differential mode through the [HYST](#) register. In single-ended mode, VUP and VDOWN thresholds can be set to implement a hysteresis using the reference ladder (see [Comparator in single-ended mode](#) on page 101). This hysteresis is in the order of magnitude of 30 mV, and shall prevent noise on the signal to create unwanted events. See [Hysteresis example where VIN+ starts below VUP](#) on page 102 for illustration of the effect of an active hysteresis on a noisy input signal.

An upward crossing will generate an UP event and a downward crossing will generate a DOWN event. The CROSS event will be generated every time there is a crossing, independent of direction.

The immediate value of the comparator can be sampled to [RESULT](#) register by triggering the SAMPLE task.

6.5.1 Differential mode

In differential mode, the reference input VIN- is derived directly from one of the AINx pins.

Before enabling the comparator via the **ENABLE** register, the following registers must be configured for the differential mode:

- **PSEL**
- **MODE**
- **EXTREFSEL**

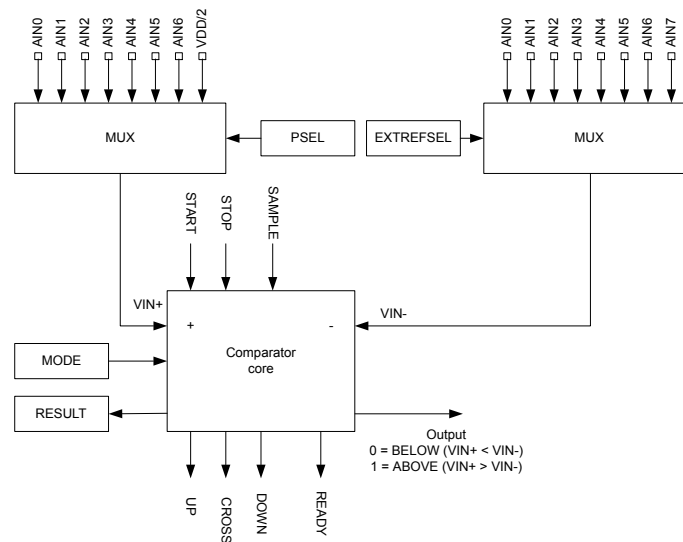

Figure 34: Comparator in differential mode

Restriction: Depending on the device, not all the analog inputs may be available for each MUX. See definitions for **PSEL** and **EXTREFSEL** for more information about which analog pins are available on a particular device.

When **HYST** register is turned on while in this mode, the output of the comparator (and associated events) will change from ABOVE to BELOW whenever VIN+ becomes lower than VIN- - ($V_{DIFFHYST} / 2$). It will also change from BELOW to ABOVE whenever VIN+ becomes higher than VIN- + ($V_{DIFFHYST} / 2$). This behavior is illustrated in [Hysteresis enabled in differential mode](#) on page 100.

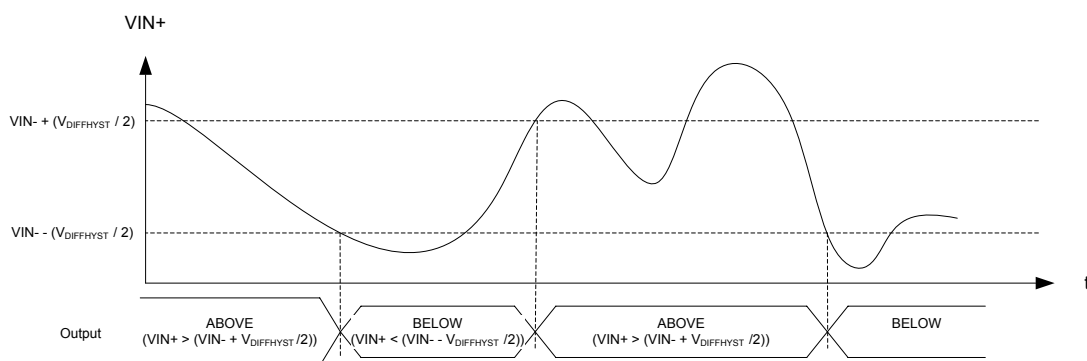

Figure 35: Hysteresis enabled in differential mode

6.5.2 Single-ended mode

In single-ended mode, VIN- is derived from the reference ladder.

Before enabling the comparator via the **ENABLE** register, the following registers must be configured for the single-ended mode:

- **PSEL**
- **MODE**
- **REFSEL**
- **EXTREFSEL**
- **TH**

The reference ladder uses the reference voltage (VREF) to derive two new voltage references, VUP and VDOWN. VUP and VDOWN are configured using THUP and THDOWN respectively in the **TH** register. VREF can be derived from any of the available reference sources, configured using the **EXTREFSEL** and **REFSEL** registers as illustrated in [Comparator in single-ended mode](#) on page 101. When AREF is selected in the **REFSEL** register, the **EXTREFSEL** register is used to select one of the AIN0-AIN7 analog input pins as reference input. The selected analog pins will be acquired by the comparator once it is enabled.

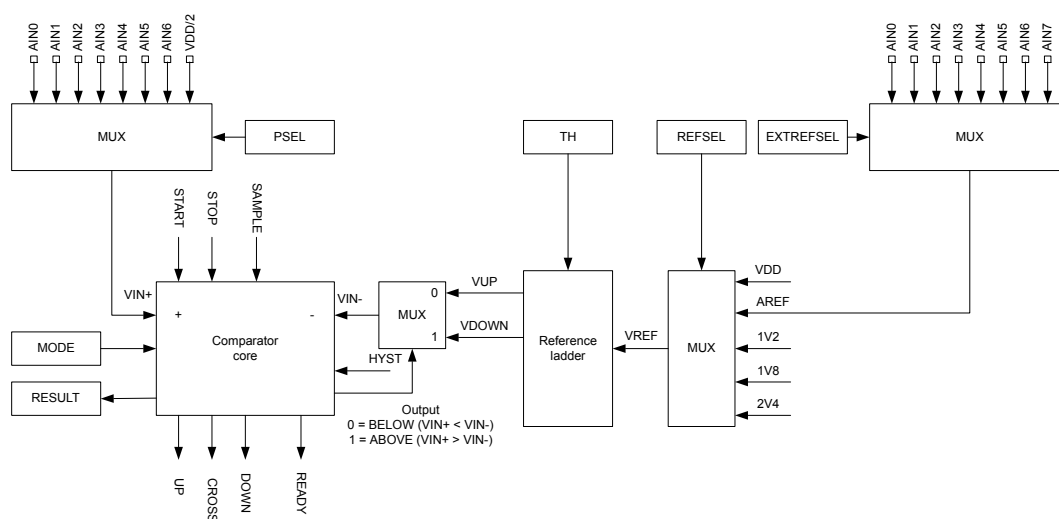

Figure 36: Comparator in single-ended mode

Restriction: Depending on the device, not all the analog inputs may be available for each MUX. See definitions for **PSEL** and **EXTREFSEL** for more information about which analog pins are available on a particular device.

When the comparator core detects that $VIN+ > VIN-$, i.e. ABOVE as per the **RESULT** register, $VIN-$ will switch to VDOWN. When $VIN+$ falls below $VIN-$ again, $VIN-$ will be switched back to VUP. By specifying VUP larger than VDOWN, a hysteresis can be generated as illustrated in [Hysteresis example where \$VIN+\$ starts below VUP](#) on page 102 and [Hysteresis example where \$VIN+\$ starts above VUP](#) on page 102.

Writing to **HYST** has no effect in single-ended mode, and the content of this register is ignored.

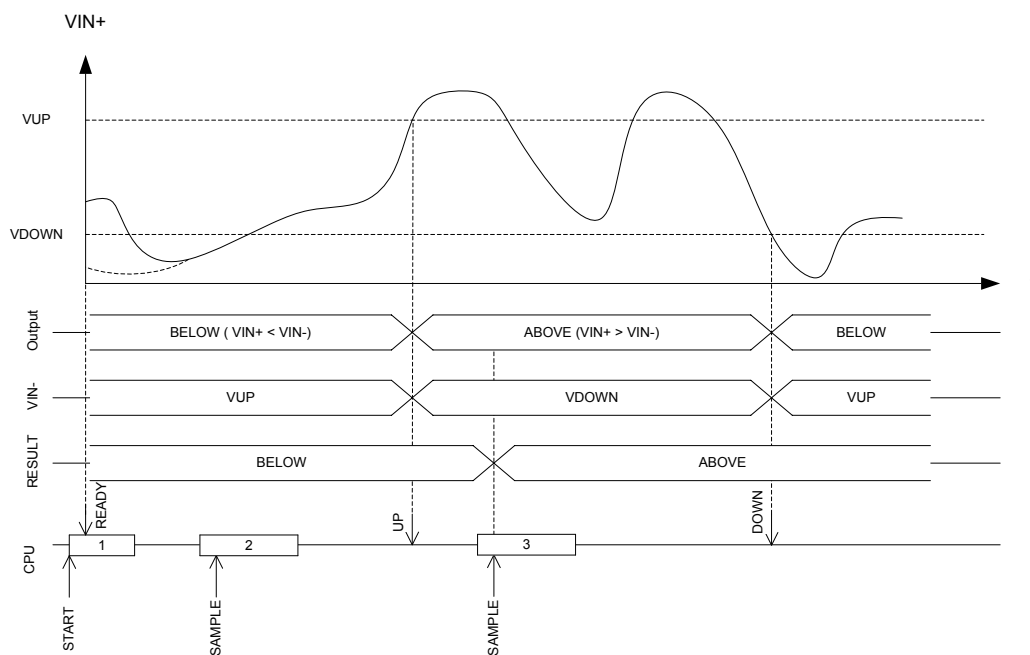

Figure 37: Hysteresis example where $VIN+$ starts below VUP

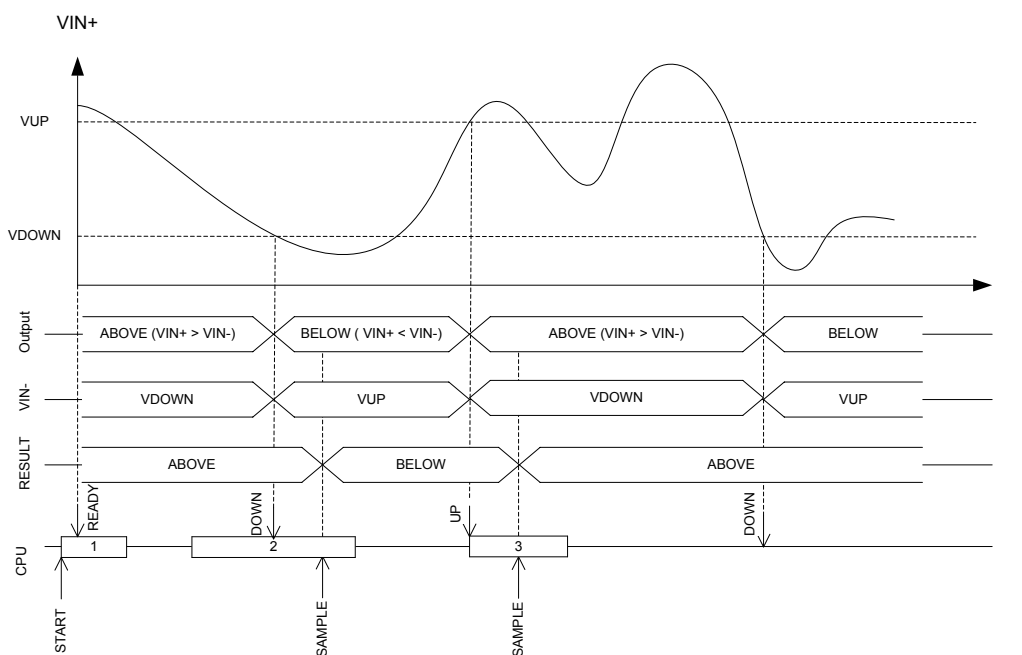

Figure 38: Hysteresis example where $VIN+$ starts above VUP

6.5.3 Registers

Base address	Peripheral	Instance	Description	Configuration
0x40013000	COMP	COMP	General purpose comparator	

Table 30: Instances

Register	Offset	Description
TASKS_START	0x000	Start comparator

Register	Offset	Description
TASKS_STOP	0x004	Stop comparator
TASKS_SAMPLE	0x008	Sample comparator value
EVENTS_READY	0x100	COMP is ready and output is valid
EVENTS_DOWN	0x104	Downward crossing
EVENTS_UP	0x108	Upward crossing
EVENTS_CROSS	0x10C	Downward or upward crossing
SHORTS	0x200	Shortcuts between local events and tasks
INTEN	0x300	Enable or disable interrupt
INTENSET	0x304	Enable interrupt
INTENCLR	0x308	Disable interrupt
RESULT	0x400	Compare result
ENABLE	0x500	COMP enable
PSEL	0x504	Pin select
REFSEL	0x508	Reference source select for single-ended mode
EXTREFSEL	0x50C	External reference select
TH	0x530	Threshold configuration for hysteresis unit
MODE	0x534	Mode configuration
HYST	0x538	Comparator hysteresis enable

Table 31: Register overview

6.5.3.1 TASKS_START

Address offset: 0x000

Start comparator

Bit number	31 30 29 28 27 26 25 24 23 22 21 20 19 18 17 16 15 14 13 12 11 10 9 8 7 6 5 4 3 2 1 0																															
ID																																A
Reset 0x00000000	0 0																															
ID	Acce	Field	Value ID	Value	Description																											
A	W	TASKS_START			Start comparator																											
			Trigger	1	Trigger task																											

6.5.3.2 TASKS_STOP

Address offset: 0x004

Stop comparator

Bit number	31 30 29 28 27 26 25 24 23 22 21 20 19 18 17 16 15 14 13 12 11 10 9 8 7 6 5 4 3 2 1 0																															
ID																																A
Reset 0x00000000	0 0																															
ID	Acce	Field	Value ID	Value	Description																											
A	W	TASKS_STOP			Stop comparator																											
			Trigger	1	Trigger task																											

6.5.3.3 TASKS_SAMPLE

Address offset: 0x008

Sample comparator value

Bit number	31	30	29	28	27	26	25	24	23	22	21	20	19	18	17	16	15	14	13	12	11	10	9	8	7	6	5	4	3	2	1	0
ID																																A
Reset 0x00000000	0 0																															
ID	Acce Field	Value ID	Value	Description																												
A	W TASKS_SAMPLE			Sample comparator value																												
		Trigger	1	Trigger task																												

6.5.3.4 EVENTS_READY

Address offset: 0x100

COMP is ready and output is valid

Bit number	31	30	29	28	27	26	25	24	23	22	21	20	19	18	17	16	15	14	13	12	11	10	9	8	7	6	5	4	3	2	1	0
ID																																A
Reset 0x00000000	0 0																															
ID	Acce Field	Value ID	Value	Description																												
A	RW EVENTS_READY			COMP is ready and output is valid																												
		NotGenerated	0	Event not generated																												
		Generated	1	Event generated																												

6.5.3.5 EVENTS_DOWN

Address offset: 0x104

Downward crossing

Bit number	31	30	29	28	27	26	25	24	23	22	21	20	19	18	17	16	15	14	13	12	11	10	9	8	7	6	5	4	3	2	1	0
ID																																A
Reset 0x00000000	0 0																															
ID	Acce Field	Value ID	Value	Description																												
A	RW EVENTS_DOWN			Downward crossing																												
		NotGenerated	0	Event not generated																												
		Generated	1	Event generated																												

6.5.3.6 EVENTS_UP

Address offset: 0x108

Upward crossing

Bit number	31	30	29	28	27	26	25	24	23	22	21	20	19	18	17	16	15	14	13	12	11	10	9	8	7	6	5	4	3	2	1	0
ID																																A
Reset 0x00000000	0 0																															
ID	Acce Field	Value ID	Value	Description																												
A	RW EVENTS_UP			Upward crossing																												
		NotGenerated	0	Event not generated																												
		Generated	1	Event generated																												

6.5.3.7 EVENTS_CROSS

Address offset: 0x10C

Downward or upward crossing

Bit number	31	30	29	28	27	26	25	24	23	22	21	20	19	18	17	16	15	14	13	12	11	10	9	8	7	6	5	4	3	2	1	0	
ID																																A	
Reset	0x00000000																																
0	0	0	0	0	0	0	0	0	0	0	0	0	0	0	0	0	0	0	0	0	0	0	0	0	0	0	0	0	0	0	0	0	0
ID	Acce Field	Value ID	Value	Description																													
A	RW EVENTS_CROSS			Downward or upward crossing																													
		NotGenerated	0	Event not generated																													
		Generated	1	Event generated																													

6.5.3.8 SHORTS

Address offset: 0x200

Shortcuts between local events and tasks

Bit number	31	30	29	28	27	26	25	24	23	22	21	20	19	18	17	16	15	14	13	12	11	10	9	8	7	6	5	4	3	2	1	0				
ID																																E	D	C	B	A
Reset	0x00000000																																			
0	0	0	0	0	0	0	0	0	0	0	0	0	0	0	0	0	0	0	0	0	0	0	0	0	0	0	0	0	0	0	0	0				
ID	Acce Field	Value ID	Value	Description																																
A	RW READY_SAMPLE			Shortcut between event READY and task SAMPLE																																
		Disabled	0	Disable shortcut																																
		Enabled	1	Enable shortcut																																
B	RW READY_STOP			Shortcut between event READY and task STOP																																
		Disabled	0	Disable shortcut																																
		Enabled	1	Enable shortcut																																
C	RW DOWN_STOP			Shortcut between event DOWN and task STOP																																
		Disabled	0	Disable shortcut																																
		Enabled	1	Enable shortcut																																
D	RW UP_STOP			Shortcut between event UP and task STOP																																
		Disabled	0	Disable shortcut																																
		Enabled	1	Enable shortcut																																
E	RW CROSS_STOP			Shortcut between event CROSS and task STOP																																
		Disabled	0	Disable shortcut																																
		Enabled	1	Enable shortcut																																

6.5.3.9 INTEN

Address offset: 0x300

Enable or disable interrupt

Bit number	31	30	29	28	27	26	25	24	23	22	21	20	19	18	17	16	15	14	13	12	11	10	9	8	7	6	5	4	3	2	1	0			
ID																																D	C	B	A
Reset	0x00000000																																		
0	0	0	0	0	0	0	0	0	0	0	0	0	0	0	0	0	0	0	0	0	0	0	0	0	0	0	0	0	0	0	0	0			
ID	Acce Field	Value ID	Value	Description																															
A	RW READY			Enable or disable interrupt for event READY																															
		Disabled	0	Disable																															
		Enabled	1	Enable																															
B	RW DOWN			Enable or disable interrupt for event DOWN																															
		Disabled	0	Disable																															
		Enabled	1	Enable																															
C	RW UP			Enable or disable interrupt for event UP																															
		Disabled	0	Disable																															
		Enabled	1	Enable																															
D	RW CROSS			Enable or disable interrupt for event CROSS																															
		Disabled	0	Disable																															

Bit number	31	30	29	28	27	26	25	24	23	22	21	20	19	18	17	16	15	14	13	12	11	10	9	8	7	6	5	4	3	2	1	0
ID																													D	C	B	A
Reset 0x00000000	0 0																															
ID	Acce Field	Value ID	Value	Description																												
		Enabled	1	Enable																												

6.5.3.10 INTENSET

Address offset: 0x304

Enable interrupt

Bit number	31	30	29	28	27	26	25	24	23	22	21	20	19	18	17	16	15	14	13	12	11	10	9	8	7	6	5	4	3	2	1	0
ID																													D	C	B	A
Reset 0x00000000	0 0																															
ID	Acce Field	Value ID	Value	Description																												
A	RW	READY		Write '1' to enable interrupt for event READY																												
		Set	1	Enable																												
		Disabled	0	Read: Disabled																												
		Enabled	1	Read: Enabled																												
B	RW	DOWN		Write '1' to enable interrupt for event DOWN																												
		Set	1	Enable																												
		Disabled	0	Read: Disabled																												
		Enabled	1	Read: Enabled																												
C	RW	UP		Write '1' to enable interrupt for event UP																												
		Set	1	Enable																												
		Disabled	0	Read: Disabled																												
		Enabled	1	Read: Enabled																												
D	RW	CROSS		Write '1' to enable interrupt for event CROSS																												
		Set	1	Enable																												
		Disabled	0	Read: Disabled																												
		Enabled	1	Read: Enabled																												

6.5.3.11 INTENCLR

Address offset: 0x308

Disable interrupt

Bit number	31	30	29	28	27	26	25	24	23	22	21	20	19	18	17	16	15	14	13	12	11	10	9	8	7	6	5	4	3	2	1	0
ID																													D	C	B	A
Reset 0x00000000	0 0																															
ID	Acce Field	Value ID	Value	Description																												
A	RW	READY		Write '1' to disable interrupt for event READY																												
		Clear	1	Disable																												
		Disabled	0	Read: Disabled																												
		Enabled	1	Read: Enabled																												
B	RW	DOWN		Write '1' to disable interrupt for event DOWN																												
		Clear	1	Disable																												
		Disabled	0	Read: Disabled																												
		Enabled	1	Read: Enabled																												
C	RW	UP		Write '1' to disable interrupt for event UP																												
		Clear	1	Disable																												
		Disabled	0	Read: Disabled																												
		Enabled	1	Read: Enabled																												

Bit number	31	30	29	28	27	26	25	24	23	22	21	20	19	18	17	16	15	14	13	12	11	10	9	8	7	6	5	4	3	2	1	0
ID																												D	C	B	A	
Reset	0x00000000																															
Reset	0 0																															
ID	Acce Field	Value ID	Value	Description																												
D	RW	CROSS		Write '1' to disable interrupt for event CROSS																												
		Clear	1	Disable																												
		Disabled	0	Read: Disabled																												
		Enabled	1	Read: Enabled																												

6.5.3.12 RESULT

Address offset: 0x400

Compare result

Bit number	31	30	29	28	27	26	25	24	23	22	21	20	19	18	17	16	15	14	13	12	11	10	9	8	7	6	5	4	3	2	1	0
ID																												A				
Reset	0x00000000																															
Reset	0 0																															
ID	Acce Field	Value ID	Value	Description																												
A	R	RESULT		Result of last compare. Decision point SAMPLE task.																												
		Below	0	Input voltage is below the threshold (VIN+ < VIN-)																												
		Above	1	Input voltage is above the threshold (VIN+ > VIN-)																												

6.5.3.13 ENABLE

Address offset: 0x500

COMP enable

Bit number	31	30	29	28	27	26	25	24	23	22	21	20	19	18	17	16	15	14	13	12	11	10	9	8	7	6	5	4	3	2	1	0
ID																												A	A			
Reset	0x00000000																															
Reset	0 0																															
ID	Acce Field	Value ID	Value	Description																												
A	RW	ENABLE		Enable or disable COMP																												
		Disabled	0	Disable																												
		Enabled	2	Enable																												

6.5.3.14 PSEL

Address offset: 0x504

Pin select

Bit number	31	30	29	28	27	26	25	24	23	22	21	20	19	18	17	16	15	14	13	12	11	10	9	8	7	6	5	4	3	2	1	0
ID																												A	A	A		
Reset 0x00000000	0 0																															
ID	Acce	Field	Value ID	Value	Description																											
A	RW	PSEL			Analog pin select																											
			AnalogInput0	0	AIN0 selected as analog input																											
			AnalogInput1	1	AIN1 selected as analog input																											
			AnalogInput2	2	AIN2 selected as analog input																											
			AnalogInput3	3	AIN3 selected as analog input																											
			AnalogInput4	4	AIN4 selected as analog input																											
			AnalogInput5	5	AIN5 selected as analog input																											
			AnalogInput6	6	AIN6 selected as analog input																											
			VddDiv2	7	VDD/2 selected as analog input																											

6.5.3.15 REFSEL

Address offset: 0x508

Reference source select for single-ended mode

Bit number	31	30	29	28	27	26	25	24	23	22	21	20	19	18	17	16	15	14	13	12	11	10	9	8	7	6	5	4	3	2	1	0
ID																												A	A	A		
Reset 0x00000004	0 1 0 0																															
ID	Acce	Field	Value ID	Value	Description																											
A	RW	REFSEL			Reference select																											
			Int1V2	0	VREF = internal 1.2 V reference (VDD >= 1.7 V)																											
			Int1V8	1	VREF = internal 1.8 V reference (VDD >= VREF + 0.2 V)																											
			Int2V4	2	VREF = internal 2.4 V reference (VDD >= VREF + 0.2 V)																											
			VDD	4	VREF = VDD																											
			ARef	5	VREF = AREF (VDD >= VREF >= AREFMIN)																											

6.5.3.16 EXTREFSEL

Address offset: 0x50C

External reference select

Bit number	31	30	29	28	27	26	25	24	23	22	21	20	19	18	17	16	15	14	13	12	11	10	9	8	7	6	5	4	3	2	1	0
ID																												A	A	A		
Reset 0x00000000	0 0																															
ID	Acce	Field	Value ID	Value	Description																											
A	RW	EXTREFSEL			External analog reference select																											
			AnalogReference0	0	Use AIN0 as external analog reference																											
			AnalogReference1	1	Use AIN1 as external analog reference																											
			AnalogReference2	2	Use AIN2 as external analog reference																											
			AnalogReference3	3	Use AIN3 as external analog reference																											
			AnalogReference4	4	Use AIN4 as external analog reference																											
			AnalogReference5	5	Use AIN5 as external analog reference																											
			AnalogReference6	6	Use AIN6 as external analog reference																											
			AnalogReference7	7	Use AIN7 as external analog reference																											

6.5.3.17 TH

Address offset: 0x530

Threshold configuration for hysteresis unit

Bit number	31 30 29 28 27 26 25 24 23 22 21 20 19 18 17 16 15 14 13 12 11 10 9 8 7 6 5 4 3 2 1 0																																																						
ID																												B	B	B	B	B	B	A	A	A	A	A	A																
Reset 0x00000000	0 0																																																						
ID	Acce Field	Value ID	Value	Description																																																			
A	RW THDOWN		[63:0]	$V_{DOWN} = (THDOWN+1)/64 * V_{REF}$																																																			
B	RW THUP		[63:0]	$V_{UP} = (THUP+1)/64 * V_{REF}$																																																			

6.5.3.18 MODE

Address offset: 0x534

Mode configuration

Bit number	31 30 29 28 27 26 25 24 23 22 21 20 19 18 17 16 15 14 13 12 11 10 9 8 7 6 5 4 3 2 1 0																																																	
ID																												B					A	A																
Reset 0x00000000	0 0																																																	
ID	Acce Field	Value ID	Value	Description																																														
A	RW SP			Speed and power modes																																														
		Low	0	Low-power mode																																														
		Normal	1	Normal mode																																														
		High	2	High-speed mode																																														
B	RW MAIN			Main operation modes																																														
		SE	0	Single-ended mode																																														
		Diff	1	Differential mode																																														

6.5.3.19 HYST

Address offset: 0x538

Comparator hysteresis enable

Bit number	31 30 29 28 27 26 25 24 23 22 21 20 19 18 17 16 15 14 13 12 11 10 9 8 7 6 5 4 3 2 1 0																																															
ID																																A																
Reset 0x00000000	0 0																																															
ID	Acce Field	Value ID	Value	Description																																												
A	RW HYST			Comparator hysteresis																																												
		NoHyst	0	Comparator hysteresis disabled																																												
		Hyst50mV	1	Comparator hysteresis enabled																																												

6.5.4 Electrical specification

6.5.4.1 COMP Electrical Specification

Symbol	Description	Min.	Typ.	Max.	Units
$t_{PROPDL,LP}$	Propagation delay, low-power mode ^a		0.6		μ S
$t_{PROPDL,N}$	Propagation delay, normal mode ^a		0.2		μ S
$t_{PROPDL,HS}$	Propagation delay, high-speed mode ^a		0.1		μ S
$V_{DIFFHYST}$	Optional hysteresis applied to differential input		30		mV

^a Propagation delay is with 10 mV overdrive.

Symbol	Description	Min.	Typ.	Max.	Units
V _{VDD-VREF}	Required difference between VDD and a selected VREF, VDD > VREF	0.3			V
t _{INT_REF,START}	Startup time for the internal bandgap reference		50	80	μS
E _{INT_REF}	Internal bandgap reference error	-3		3	%
V _{INPUTOFFSET}	Input offset	-10		10	mV
t _{COMP,START}	Startup time for the comparator core		3		μS

6.6 ECB — AES electronic codebook mode encryption

The AES electronic codebook mode encryption (ECB) can be used for a range of cryptographic functions like hash generation, digital signatures, and keystream generation for data encryption/decryption. The ECB encryption block supports 128 bit AES encryption (encryption only, not decryption).

AES ECB operates with EasyDMA access to system Data RAM for in-place operations on cleartext and ciphertext during encryption. ECB uses the same AES core as the CCM and AAR blocks and is an asynchronous operation which may not complete if the AES core is busy.

AES ECB features:

- 128 bit AES encryption
- Supports standard AES ECB block encryption
- Memory pointer support
- DMA data transfer

AES ECB performs a 128 bit AES block encrypt. At the STARTECB task, data and key is loaded into the algorithm by EasyDMA. When output data has been written back to memory, the ENDECB event is triggered.

AES ECB can be stopped by triggering the STOPECB task.

6.6.1 Shared resources

The ECB, CCM, and AAR share the same AES module. The ECB will always have lowest priority and if there is a sharing conflict during encryption, the ECB operation will be aborted and an ERRORECB event will be generated.

6.6.2 EasyDMA

The ECB implements an EasyDMA mechanism for reading and writing to the Data RAM. This DMA cannot access the program memory or any other parts of the memory area except RAM.

If the ECBDATAPTR is not pointing to the Data RAM region, an EasyDMA transfer may result in a HardFault or RAM corruption. See [Memory](#) on page 17 for more information about the different memory regions.

The EasyDMA will have finished accessing the Data RAM when the ENDECB or ERRORECB is generated.

6.6.3 ECB data structure

Input to the block encrypt and output from the block encrypt are stored in the same data structure. ECBDATAPTR should point to this data structure before STARTECB is initiated.

Property	Address offset	Description
KEY	0	16 byte AES key
CLEARTTEXT	16	16 byte AES cleartext input block
CIPHERTEXT	32	16 byte AES ciphertext output block

Table 32: ECB data structure overview

6.6.4 Registers

Base address	Peripheral	Instance	Description	Configuration
0x4000E000	ECB	ECB	AES Electronic Codebook (ECB) mode block encryption	

Table 33: Instances

Register	Offset	Description
TASKS_STARTECB	0x000	Start ECB block encrypt
TASKS_STOPECB	0x004	Abort a possible executing ECB operation
EVENTS_ENDECB	0x100	ECB block encrypt complete
EVENTS_ERRORECB	0x104	ECB block encrypt aborted because of a STOPECB task or due to an error
INTENSET	0x304	Enable interrupt
INTENCLR	0x308	Disable interrupt
ECBDATAPTR	0x504	ECB block encrypt memory pointers

Table 34: Register overview

6.6.4.1 TASKS_STARTECB

Address offset: 0x000

Start ECB block encrypt

If a crypto operation is already running in the AES core, the STARTECB task will not start a new encryption and an ERRORECB event will be triggered

Bit number	31 30 29 28 27 26 25 24 23 22 21 20 19 18 17 16 15 14 13 12 11 10 9 8 7 6 5 4 3 2 1 0																															
ID																																A
Reset 0x00000000	0 0																															
ID	Acce	Field	Value	ID	Value	Description																										
A	W	TASKS_STARTECB				Start ECB block encrypt																										
						If a crypto operation is already running in the AES core, the STARTECB task will not start a new encryption and an ERRORECB event will be triggered																										
			Trigger		1	Trigger task																										

6.6.4.2 TASKS_STOPECB

Address offset: 0x004

Abort a possible executing ECB operation

If a running ECB operation is aborted by STOPECB, the ERRORECB event is triggered.

Bit number	31 30 29 28 27 26 25 24 23 22 21 20 19 18 17 16 15 14 13 12 11 10 9 8 7 6 5 4 3 2 1 0																															
ID																																A
Reset 0x00000000	0 0																															
ID	Acce	Field	Value	ID	Value	Description																										
A	W	TASKS_STOPECB				Abort a possible executing ECB operation																										
						If a running ECB operation is aborted by STOPECB, the ERRORECB event is triggered.																										
			Trigger		1	Trigger task																										

6.6.4.3 EVENTS_ENDECB

Address offset: 0x100

ECB block encrypt complete

Bit number	31	30	29	28	27	26	25	24	23	22	21	20	19	18	17	16	15	14	13	12	11	10	9	8	7	6	5	4	3	2	1	0
ID																																A
Reset 0x00000000	0 0																															
ID	Acce	Field	Value ID	Value	Description																											
A	RW	EVENTS_ENDECB			ECB block encrypt complete																											
			NotGenerated	0	Event not generated																											
			Generated	1	Event generated																											

6.6.4.4 EVENTS_ERRORECB

Address offset: 0x104

ECB block encrypt aborted because of a STOPECB task or due to an error

Bit number	31	30	29	28	27	26	25	24	23	22	21	20	19	18	17	16	15	14	13	12	11	10	9	8	7	6	5	4	3	2	1	0
ID																																A
Reset 0x00000000	0 0																															
ID	Acce	Field	Value ID	Value	Description																											
A	RW	EVENTS_ERRORECB			ECB block encrypt aborted because of a STOPECB task or due to an error																											
			NotGenerated	0	Event not generated																											
			Generated	1	Event generated																											

6.6.4.5 INTENSET

Address offset: 0x304

Enable interrupt

Bit number	31	30	29	28	27	26	25	24	23	22	21	20	19	18	17	16	15	14	13	12	11	10	9	8	7	6	5	4	3	2	1	0
ID																																B A
Reset 0x00000000	0 0																															
ID	Acce	Field	Value ID	Value	Description																											
A	RW	ENDECB			Write '1' to enable interrupt for event ENDECB																											
			Set	1	Enable																											
			Disabled	0	Read: Disabled																											
			Enabled	1	Read: Enabled																											
B	RW	ERRORECB			Write '1' to enable interrupt for event ERRORECB																											
			Set	1	Enable																											
			Disabled	0	Read: Disabled																											
			Enabled	1	Read: Enabled																											

6.6.4.6 INTENCLR

Address offset: 0x308

Disable interrupt

Bit number	31 30 29 28 27 26 25 24 23 22 21 20 19 18 17 16 15 14 13 12 11 10 9 8 7 6 5 4 3 2 1 0																															
ID																															B	A
Reset	0x00000000																															
ID	Acce Field	Value ID	Value	Description																												
A	RW ENDECB			Write '1' to disable interrupt for event ENDECB																												
		Clear	1	Disable																												
		Disabled	0	Read: Disabled																												
		Enabled	1	Read: Enabled																												
B	RW ERRORECB			Write '1' to disable interrupt for event ERRORECB																												
		Clear	1	Disable																												
		Disabled	0	Read: Disabled																												
		Enabled	1	Read: Enabled																												

6.6.4.7 ECBDATAPTR

Address offset: 0x504

ECB block encrypt memory pointers

Bit number	31 30 29 28 27 26 25 24 23 22 21 20 19 18 17 16 15 14 13 12 11 10 9 8 7 6 5 4 3 2 1 0																															
ID	A																														A	A
Reset	0x00000000																															
ID	Acce Field	Value ID	Value	Description																												
A	RW ECBDATAPTR			Pointer to the ECB data structure (see Table 1 ECB data structure overview)																												

6.6.5 Electrical specification

6.6.5.1 ECB Electrical Specification

Symbol	Description	Min.	Typ.	Max.	Units
t_{ECB}	Run time per 16 byte block in all modes		6		μ s

6.7 EGU — Event generator unit

The Event generator unit (EGU) provides support for inter-layer signaling. This means support for atomic triggering of both CPU execution and hardware tasks from both firmware (by CPU) and hardware (by PPI). This feature can, for instance, be used for triggering CPU execution at a lower priority execution from a higher priority execution, or to handle a peripheral's ISR execution at a lower priority for some of its events. However, triggering any priority from any priority is possible.

Listed here are the main EGU features:

- Enables SW triggering of interrupts
- Separate interrupt vectors for every EGU instance
- Up to 16 separate event flags per interrupt for multiplexing

Each instance of The EGU implements a set of tasks which can individually be triggered to generate the corresponding event, i.e., the corresponding event for `TASKS_TRIGGER[n]` is `EVENTS_TRIGGERED[n]`.

Refer to [Instances](#) on page 114 for a list of the various EGU instances

6.7.1 Registers

Base address	Peripheral	Instance	Description	Configuration
0x40014000	EGU	EGU0	Event generator unit 0	
0x40015000	EGU	EGU1	Event generator unit 1	

Table 35: Instances

Register	Offset	Description
TASKS_TRIGGER[0]	0x000	Trigger 0 for triggering the corresponding TRIGGERED[0] event
TASKS_TRIGGER[1]	0x004	Trigger 1 for triggering the corresponding TRIGGERED[1] event
TASKS_TRIGGER[2]	0x008	Trigger 2 for triggering the corresponding TRIGGERED[2] event
TASKS_TRIGGER[3]	0x00C	Trigger 3 for triggering the corresponding TRIGGERED[3] event
TASKS_TRIGGER[4]	0x010	Trigger 4 for triggering the corresponding TRIGGERED[4] event
TASKS_TRIGGER[5]	0x014	Trigger 5 for triggering the corresponding TRIGGERED[5] event
TASKS_TRIGGER[6]	0x018	Trigger 6 for triggering the corresponding TRIGGERED[6] event
TASKS_TRIGGER[7]	0x01C	Trigger 7 for triggering the corresponding TRIGGERED[7] event
TASKS_TRIGGER[8]	0x020	Trigger 8 for triggering the corresponding TRIGGERED[8] event
TASKS_TRIGGER[9]	0x024	Trigger 9 for triggering the corresponding TRIGGERED[9] event
TASKS_TRIGGER[10]	0x028	Trigger 10 for triggering the corresponding TRIGGERED[10] event
TASKS_TRIGGER[11]	0x02C	Trigger 11 for triggering the corresponding TRIGGERED[11] event
TASKS_TRIGGER[12]	0x030	Trigger 12 for triggering the corresponding TRIGGERED[12] event
TASKS_TRIGGER[13]	0x034	Trigger 13 for triggering the corresponding TRIGGERED[13] event
TASKS_TRIGGER[14]	0x038	Trigger 14 for triggering the corresponding TRIGGERED[14] event
TASKS_TRIGGER[15]	0x03C	Trigger 15 for triggering the corresponding TRIGGERED[15] event
EVENTS_TRIGGERED[0]	0x100	Event number 0 generated by triggering the corresponding TRIGGER[0] task
EVENTS_TRIGGERED[1]	0x104	Event number 1 generated by triggering the corresponding TRIGGER[1] task
EVENTS_TRIGGERED[2]	0x108	Event number 2 generated by triggering the corresponding TRIGGER[2] task
EVENTS_TRIGGERED[3]	0x10C	Event number 3 generated by triggering the corresponding TRIGGER[3] task
EVENTS_TRIGGERED[4]	0x110	Event number 4 generated by triggering the corresponding TRIGGER[4] task
EVENTS_TRIGGERED[5]	0x114	Event number 5 generated by triggering the corresponding TRIGGER[5] task
EVENTS_TRIGGERED[6]	0x118	Event number 6 generated by triggering the corresponding TRIGGER[6] task
EVENTS_TRIGGERED[7]	0x11C	Event number 7 generated by triggering the corresponding TRIGGER[7] task
EVENTS_TRIGGERED[8]	0x120	Event number 8 generated by triggering the corresponding TRIGGER[8] task
EVENTS_TRIGGERED[9]	0x124	Event number 9 generated by triggering the corresponding TRIGGER[9] task
EVENTS_TRIGGERED[10]	0x128	Event number 10 generated by triggering the corresponding TRIGGER[10] task
EVENTS_TRIGGERED[11]	0x12C	Event number 11 generated by triggering the corresponding TRIGGER[11] task
EVENTS_TRIGGERED[12]	0x130	Event number 12 generated by triggering the corresponding TRIGGER[12] task
EVENTS_TRIGGERED[13]	0x134	Event number 13 generated by triggering the corresponding TRIGGER[13] task
EVENTS_TRIGGERED[14]	0x138	Event number 14 generated by triggering the corresponding TRIGGER[14] task
EVENTS_TRIGGERED[15]	0x13C	Event number 15 generated by triggering the corresponding TRIGGER[15] task
INTEN	0x300	Enable or disable interrupt
INTENSET	0x304	Enable interrupt
INTENCLR	0x308	Disable interrupt

Table 36: Register overview

6.7.1.1 TASKS_TRIGGER[n] (n=0..15)

Address offset: $0x000 + (n \times 0x4)$

Trigger n for triggering the corresponding TRIGGERED[n] event

Bit number	31	30	29	28	27	26	25	24	23	22	21	20	19	18	17	16	15	14	13	12	11	10	9	8	7	6	5	4	3	2	1	0
ID																																A
Reset	0x00000000																															
0	0	0	0	0	0	0	0	0	0	0	0	0	0	0	0	0	0	0	0	0	0	0	0	0	0	0	0	0	0	0	0	0
ID	Acce Field	Value ID	Value	Description																												
A	W	TASKS_TRIGGER		Trigger n for triggering the corresponding TRIGGERED[n] event																												
		Trigger	1	Trigger task																												

6.7.1.2 EVENTS_TRIGGERED[n] (n=0..15)

Address offset: $0x100 + (n \times 0x4)$

Event number n generated by triggering the corresponding TRIGGER[n] task

Bit number	31	30	29	28	27	26	25	24	23	22	21	20	19	18	17	16	15	14	13	12	11	10	9	8	7	6	5	4	3	2	1	0
ID																																A
Reset	0x00000000																															
0	0	0	0	0	0	0	0	0	0	0	0	0	0	0	0	0	0	0	0	0	0	0	0	0	0	0	0	0	0	0	0	
ID	Acce Field	Value ID	Value	Description																												
A	RW	EVENTS_TRIGGERED		Event number n generated by triggering the corresponding TRIGGER[n] task																												
		NotGenerated	0	Event not generated																												
		Generated	1	Event generated																												

6.7.1.3 INTEN

Address offset: 0x300

Enable or disable interrupt

Bit number	31	30	29	28	27	26	25	24	23	22	21	20	19	18	17	16	15	14	13	12	11	10	9	8	7	6	5	4	3	2	1	0
ID																																P O N M L K J I H G F E D C B A
Reset	0x00000000																															
0	0	0	0	0	0	0	0	0	0	0	0	0	0	0	0	0	0	0	0	0	0	0	0	0	0	0	0	0	0	0	0	
ID	Acce Field	Value ID	Value	Description																												
A-P	RW	TRIGGERED[i] (i=0..15)		Enable or disable interrupt for event TRIGGERED[i]																												
		Disabled	0	Disable																												
		Enabled	1	Enable																												

6.7.1.4 INTENSET

Address offset: 0x304

Enable interrupt

Bit number	31	30	29	28	27	26	25	24	23	22	21	20	19	18	17	16	15	14	13	12	11	10	9	8	7	6	5	4	3	2	1	0
ID																																P O N M L K J I H G F E D C B A
Reset	0x00000000																															
0	0	0	0	0	0	0	0	0	0	0	0	0	0	0	0	0	0	0	0	0	0	0	0	0	0	0	0	0	0	0	0	
ID	Acce Field	Value ID	Value	Description																												
A-P	RW	TRIGGERED[i] (i=0..15)		Write '1' to enable interrupt for event TRIGGERED[i]																												
		Set	1	Enable																												
		Disabled	0	Read: Disabled																												
		Enabled	1	Read: Enabled																												

6.7.1.5 INTENCLR

Address offset: 0x308

Disable interrupt

Bit number	31	30	29	28	27	26	25	24	23	22	21	20	19	18	17	16	15	14	13	12	11	10	9	8	7	6	5	4	3	2	1	0		
ID																	P	O	N	M	L	K	J	I	H	G	F	E	D	C	B	A		
Reset 0x00000000	0																0	0	0	0	0	0	0	0	0	0	0	0	0	0	0	0	0	0
ID	Acce Field	Value ID	Value	Description																														
A-P	RW	TRIGGERED[i] (i=0..15)		Write '1' to disable interrupt for event TRIGGERED[i]																														
		Clear	1	Disable																														
		Disabled	0	Read: Disabled																														
		Enabled	1	Read: Enabled																														

6.7.2 Electrical specification

6.7.2.1 EGU Electrical Specification

Symbol	Description	Min.	Typ.	Max.	Units
$t_{\text{EGU,EVT}}$	Latency between setting an EGU event flag and the system setting an interrupt		1		cycles

6.8 GPIO — General purpose input/output

The general purpose input/output pins (GPIOs) are grouped as one or more ports with each port having up to 32 GPIOs.

The number of ports and GPIOs per port might vary with product variant and package. Refer to [Registers](#) on page 118 and [Pin assignments](#) on page 387 for more information about the number of GPIOs that are supported.

GPIO has the following user-configurable features:

- Up to 32 GPIO pins per GPIO port
- Configurable output drive strength
- Internal pull-up and pull-down resistors
- Wake-up from high or low level triggers on all pins
- Trigger interrupt on state changes on any pin
- All pins can be used by the PPI task/event system
- One or more GPIO outputs can be controlled through PPI and GPIOTE channels
- All pins can be individually mapped to interface blocks for layout flexibility
- GPIO state changes captured on SENSE signal can be stored by LATCH register

The GPIO port peripheral implements up to 32 pins, PIN_0 through PIN_{31} . Each of these pins can be individually configured in the $\text{PIN_CNF}[n]$ registers ($n=0..31$).

The following parameters can be configured through these registers:

- Direction
- Drive strength
- Enabling of pull-up and pull-down resistors
- Pin sensing
- Input buffer disconnect
- Analog input (for selected pins)

The PIN_CNF registers are retained registers. See [POWER — Power supply](#) on page 49 chapter for more information about retained registers.

6.8.1 Pin configuration

Pins can be individually configured, through the SENSE field in the PIN_CNF[n] register, to detect either a high level or a low level on their input.

When the correct level is detected on any such configured pin, the sense mechanism will set the DETECT signal high. Each pin has a separate DETECT signal. Default behavior, defined by the DETECTMODE register, is that the DETECT signals from all pins in the GPIO port are combined into one common DETECT signal that is routed throughout the system, which then can be utilized by other peripherals. This mechanism is functional in both System ON mode and System OFF mode. See [GPIO port and the GPIO pin details](#) on page 117.

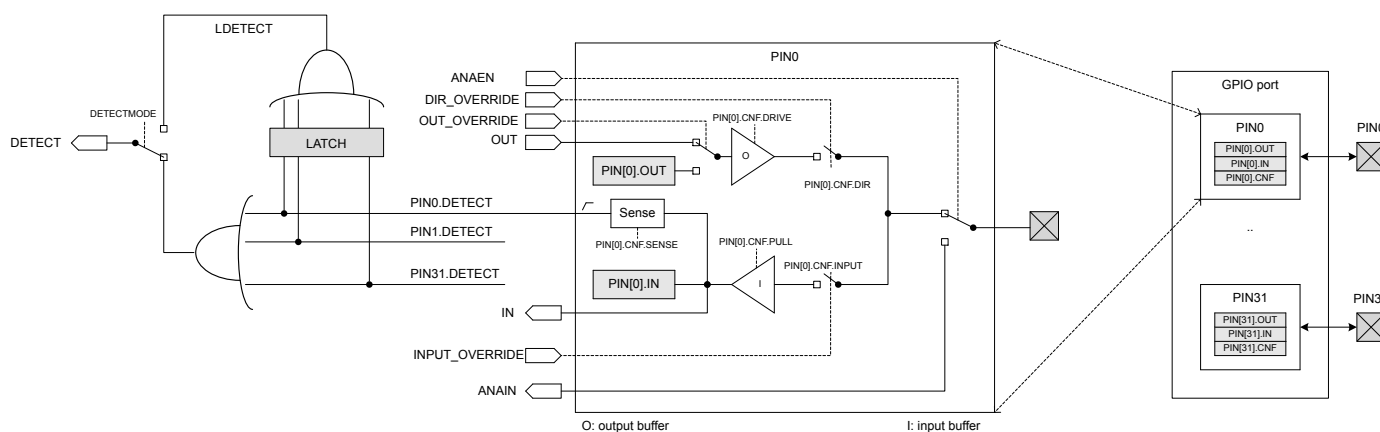

Figure 39: GPIO port and the GPIO pin details

[GPIO port and the GPIO pin details](#) on page 117 illustrates the GPIO port containing 32 individual pins, where PIN0 is illustrated in more detail as a reference. All signals on the left side in the illustration are used by other peripherals in the system and therefore not directly available to the CPU.

Make sure that a pin is in a level that cannot trigger the sense mechanism before enabling it. The DETECT signal will go high immediately if the SENSE condition configured in the PIN_CNF registers is met when the sense mechanism is enabled. This will trigger a PORT event if the DETECT signal was low before enabling the sense mechanism. See [GPIO — GPIO tasks and events](#) on page 124.

See the following peripherals for more information about how the DETECT signal is used:

- POWER: uses the DETECT signal to exit from System OFF mode.
- GPIOTE: uses the DETECT signal to generate the PORT event.

When a pin's PINx.DETECT signal goes high, a flag will be set in the LATCH register. For example, when the PIN0.DETECT signal goes high, bit 0 in the LATCH register will be set to '1'. If the CPU performs a clear operation on a bit in the LATCH register when the associated PINx.DETECT signal is high, the bit in the LATCH register will not be cleared. The LATCH register will only be cleared if the CPU explicitly clears it by writing a '1' to the bit that shall be cleared, i.e. the LATCH register will not be affected by a PINx.DETECT signal being set low.

The LDETECT signal will be set high when one or more bits in the LATCH register are '1'. The LDETECT signal will be set low when all bits in the LATCH register are successfully cleared to '0'.

If one or more bits in the LATCH register are '1' after the CPU has performed a clear operation on the LATCH registers, a rising edge will be generated on the LDETECT signal. This is illustrated in [DETECT signal behavior](#) on page 118.

Important: The CPU can read the LATCH register at any time to check if a SENSE condition has been met on one or more of the the GPIO pins, even if that condition is no longer met at the time the CPU queries the LATCH register. This mechanism will work even if the LDETECT signal is not used as the DETECT signal.

The LDETECT signal is by default not connected to the GPIO port's DETECT signal, but via the DETECTMODE register it is possible to change from default behavior to DETECT signal being derived directly from the LDETECT signal instead. See [GPIO port and the GPIO pin details](#) on page 117. [DETECT signal behavior](#) on page 118 illustrates the DETECT signal behavior for these two alternatives.

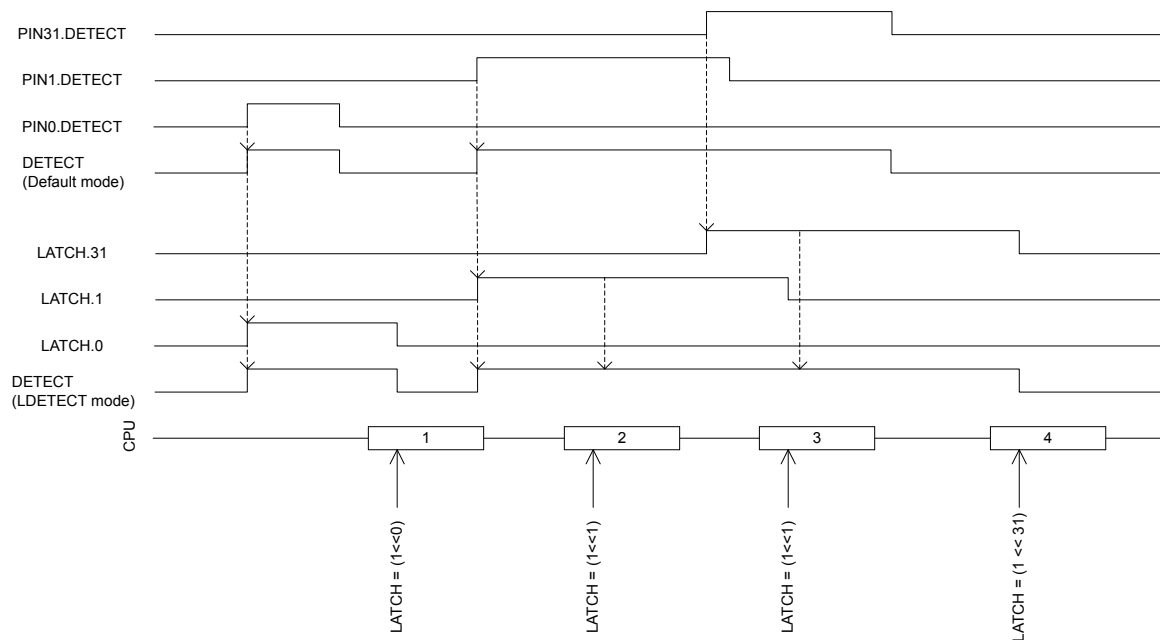

Figure 40: DETECT signal behavior

The input buffer of a GPIO pin can be disconnected from the pin to enable power savings when the pin is not used as an input, see [GPIO port and the GPIO pin details](#) on page 117. Inputs must be connected to get a valid input value in the IN register, and for the sense mechanism to get access to the pin.

Other peripherals in the system can connect to GPIO pins and override their output value and configuration, or read their analog or digital input value. See [GPIO port and the GPIO pin details](#) on page 117.

Selected pins also support analog input signals, see ANAIN in [GPIO port and the GPIO pin details](#) on page 117. The assignment of the analog pins can be found in [Pin assignments](#) on page 387.

Important: When a pin is configured as digital input, care has been taken to minimize increased current consumption when the input voltage is between V_{IL} and V_{IH} . However, it is a good practice to ensure that the external circuitry does not drive that pin to levels between V_{IL} and V_{IH} for a long period of time.

6.8.2 Registers

Base address	Peripheral	Instance	Description	Configuration
0x50000000	GPIO	P0	General purpose input and output	

Table 37: Instances

Register	Offset	Description
OUT	0x504	Write GPIO port

Register	Offset	Description
OUTSET	0x508	Set individual bits in GPIO port
OUTCLR	0x50C	Clear individual bits in GPIO port
IN	0x510	Read GPIO port
DIR	0x514	Direction of GPIO pins
DIRSET	0x518	DIR set register
DIRCLR	0x51C	DIR clear register
LATCH	0x520	Latch register indicating what GPIO pins that have met the criteria set in the PIN_CNF[n].SENSE registers
DETECTMODE	0x524	Select between default DETECT signal behaviour and LDETECT mode
PIN_CNF[0]	0x700	Configuration of GPIO pins
PIN_CNF[1]	0x704	Configuration of GPIO pins
PIN_CNF[2]	0x708	Configuration of GPIO pins
PIN_CNF[3]	0x70C	Configuration of GPIO pins
PIN_CNF[4]	0x710	Configuration of GPIO pins
PIN_CNF[5]	0x714	Configuration of GPIO pins
PIN_CNF[6]	0x718	Configuration of GPIO pins
PIN_CNF[7]	0x71C	Configuration of GPIO pins
PIN_CNF[8]	0x720	Configuration of GPIO pins
PIN_CNF[9]	0x724	Configuration of GPIO pins
PIN_CNF[10]	0x728	Configuration of GPIO pins
PIN_CNF[11]	0x72C	Configuration of GPIO pins
PIN_CNF[12]	0x730	Configuration of GPIO pins
PIN_CNF[13]	0x734	Configuration of GPIO pins
PIN_CNF[14]	0x738	Configuration of GPIO pins
PIN_CNF[15]	0x73C	Configuration of GPIO pins
PIN_CNF[16]	0x740	Configuration of GPIO pins
PIN_CNF[17]	0x744	Configuration of GPIO pins
PIN_CNF[18]	0x748	Configuration of GPIO pins
PIN_CNF[19]	0x74C	Configuration of GPIO pins
PIN_CNF[20]	0x750	Configuration of GPIO pins
PIN_CNF[21]	0x754	Configuration of GPIO pins
PIN_CNF[22]	0x758	Configuration of GPIO pins
PIN_CNF[23]	0x75C	Configuration of GPIO pins
PIN_CNF[24]	0x760	Configuration of GPIO pins
PIN_CNF[25]	0x764	Configuration of GPIO pins
PIN_CNF[26]	0x768	Configuration of GPIO pins
PIN_CNF[27]	0x76C	Configuration of GPIO pins
PIN_CNF[28]	0x770	Configuration of GPIO pins
PIN_CNF[29]	0x774	Configuration of GPIO pins
PIN_CNF[30]	0x778	Configuration of GPIO pins
PIN_CNF[31]	0x77C	Configuration of GPIO pins

Table 38: Register overview

6.8.2.1 OUT

Address offset: 0x504

Write GPIO port

Bit number	31	30	29	28	27	26	25	24	23	22	21	20	19	18	17	16	15	14	13	12	11	10	9	8	7	6	5	4	3	2	1	0
ID	f	e	d	c	b	a	Z	Y	X	W	V	U	T	S	R	Q	P	O	N	M	L	K	J	I	H	G	F	E	D	C	B	A
Reset 0x00000000	0	0	0	0	0	0	0	0	0	0	0	0	0	0	0	0	0	0	0	0	0	0	0	0	0	0	0	0	0	0	0	0
ID	Acce	Field	Value ID	Value	Description																											
A-f	RW	PIN[i] (i=0..31)			Pin i																											
			Low	0	Pin driver is low																											
			High	1	Pin driver is high																											

6.8.2.2 OUTSET

Address offset: 0x508

Set individual bits in GPIO port

Read: reads value of OUT register.

Bit number	31	30	29	28	27	26	25	24	23	22	21	20	19	18	17	16	15	14	13	12	11	10	9	8	7	6	5	4	3	2	1	0
ID	f	e	d	c	b	a	Z	Y	X	W	V	U	T	S	R	Q	P	O	N	M	L	K	J	I	H	G	F	E	D	C	B	A
Reset 0x00000000	0	0	0	0	0	0	0	0	0	0	0	0	0	0	0	0	0	0	0	0	0	0	0	0	0	0	0	0	0	0	0	0
ID	Acce	Field	Value ID	Value	Description																											
A-f	RW	PIN[i] (i=0..31)			Pin i																											
			Low	0	Read: pin driver is low																											
			High	1	Read: pin driver is high																											
			Set	1	Write: writing a '1' sets the pin high; writing a '0' has no effect																											

6.8.2.3 OUTCLR

Address offset: 0x50C

Clear individual bits in GPIO port

Read: reads value of OUT register.

Bit number	31	30	29	28	27	26	25	24	23	22	21	20	19	18	17	16	15	14	13	12	11	10	9	8	7	6	5	4	3	2	1	0
ID	f	e	d	c	b	a	Z	Y	X	W	V	U	T	S	R	Q	P	O	N	M	L	K	J	I	H	G	F	E	D	C	B	A
Reset 0x00000000	0	0	0	0	0	0	0	0	0	0	0	0	0	0	0	0	0	0	0	0	0	0	0	0	0	0	0	0	0	0	0	0
ID	Acce	Field	Value ID	Value	Description																											
A-f	RW	PIN[i] (i=0..31)			Pin i																											
			Low	0	Read: pin driver is low																											
			High	1	Read: pin driver is high																											
			Clear	1	Write: writing a '1' sets the pin low; writing a '0' has no effect																											

6.8.2.4 IN

Address offset: 0x510

Read GPIO port

Bit number	31	30	29	28	27	26	25	24	23	22	21	20	19	18	17	16	15	14	13	12	11	10	9	8	7	6	5	4	3	2	1	0
ID	f	e	d	c	b	a	Z	Y	X	W	V	U	T	S	R	Q	P	O	N	M	L	K	J	I	H	G	F	E	D	C	B	A
Reset	0	0	0	0	0	0	0	0	0	0	0	0	0	0	0	0	0	0	0	0	0	0	0	0	0	0	0	0	0	0	0	0
ID	Acce	Field	Value ID	Value	Description																											
A-f	R	PIN[i] (i=0..31)			Pin i																											
			Low	0	Pin input is low																											
			High	1	Pin input is high																											

6.8.2.5 DIR

Address offset: 0x514

Direction of GPIO pins

Bit number	31	30	29	28	27	26	25	24	23	22	21	20	19	18	17	16	15	14	13	12	11	10	9	8	7	6	5	4	3	2	1	0
ID	f	e	d	c	b	a	Z	Y	X	W	V	U	T	S	R	Q	P	O	N	M	L	K	J	I	H	G	F	E	D	C	B	A
Reset	0	0	0	0	0	0	0	0	0	0	0	0	0	0	0	0	0	0	0	0	0	0	0	0	0	0	0	0	0	0	0	
ID	Acce	Field	Value ID	Value	Description																											
A-f	RW	PIN[i] (i=0..31)			Pin i																											
			Input	0	Pin set as input																											
			Output	1	Pin set as output																											

6.8.2.6 DIRSET

Address offset: 0x518

DIR set register

Read: reads value of DIR register.

Bit number	31	30	29	28	27	26	25	24	23	22	21	20	19	18	17	16	15	14	13	12	11	10	9	8	7	6	5	4	3	2	1	0
ID	f	e	d	c	b	a	Z	Y	X	W	V	U	T	S	R	Q	P	O	N	M	L	K	J	I	H	G	F	E	D	C	B	A
Reset	0	0	0	0	0	0	0	0	0	0	0	0	0	0	0	0	0	0	0	0	0	0	0	0	0	0	0	0	0	0	0	
ID	Acce	Field	Value ID	Value	Description																											
A-f	RW	PIN[i] (i=0..31)			Set as output pin i																											
			Input	0	Read: pin set as input																											
			Output	1	Read: pin set as output																											
			Set	1	Write: writing a '1' sets pin to output; writing a '0' has no effect																											

6.8.2.7 DIRCLR

Address offset: 0x51C

DIR clear register

Read: reads value of DIR register.

Bit number	31	30	29	28	27	26	25	24	23	22	21	20	19	18	17	16	15	14	13	12	11	10	9	8	7	6	5	4	3	2	1	0
ID	f e d c b a Z Y X W V U T S R Q P O N M L K J I H G F E D C B A																															
Reset 0x00000000	0 0																															
ID	Acce Field	Value ID	Value	Description																												
A-f	RW	PIN[i] (i=0..31)		Set as input pin i																												
		Input	0	Read: pin set as input																												
		Output	1	Read: pin set as output																												
		Clear	1	Write: writing a '1' sets pin to input; writing a '0' has no effect																												

6.8.2.8 LATCH

Address offset: 0x520

Latch register indicating what GPIO pins that have met the criteria set in the PIN_CNF[n].SENSE registers

Bit number	31	30	29	28	27	26	25	24	23	22	21	20	19	18	17	16	15	14	13	12	11	10	9	8	7	6	5	4	3	2	1	0
ID	f e d c b a Z Y X W V U T S R Q P O N M L K J I H G F E D C B A																															
Reset 0x00000000	0 0																															
ID	Acce Field	Value ID	Value	Description																												
A-f	RW	PIN[i] (i=0..31)		Status on whether PINi has met criteria set in PIN_CNF _i .SENSE register. Write '1' to clear.																												
		NotLatched	0	Criteria has not been met																												
		Latched	1	Criteria has been met																												

6.8.2.9 DETECTMODE

Address offset: 0x524

Select between default DETECT signal behaviour and LDETECT mode

Bit number	31	30	29	28	27	26	25	24	23	22	21	20	19	18	17	16	15	14	13	12	11	10	9	8	7	6	5	4	3	2	1	0
ID																																A
Reset 0x00000000	0 0																															
ID	Acce Field	Value ID	Value	Description																												
A	RW	DETECTMODE		Select between default DETECT signal behaviour and LDETECT mode																												
		Default	0	DETECT directly connected to PIN DETECT signals																												
		LDETECT	1	Use the latched LDETECT behaviour																												

6.8.2.10 PIN_CNF[n] (n=0..31)

Address offset: 0x700 + (n × 0x4)

Configuration of GPIO pins

Bit number	31	30	29	28	27	26	25	24	23	22	21	20	19	18	17	16	15	14	13	12	11	10	9	8	7	6	5	4	3	2	1	0		
ID																	E	E							D	D	D				C	C	B	A
Reset 0x00000002	0 1 0																																	
ID	Acce Field	Value ID	Value	Description																														
A	RW	DIR		Pin direction. Same physical register as DIR register																														
		Input	0	Configure pin as an input pin																														
		Output	1	Configure pin as an output pin																														
B	RW	INPUT		Connect or disconnect input buffer																														
		Connect	0	Connect input buffer																														

Bit number		31 30 29 28 27 26 25 24 23 22 21 20 19 18 17 16 15 14 13 12 11 10 9 8 7 6 5 4 3 2 1 0																											
ID		E E																D D D			C C B A								
Reset 0x00000002		0 1 0																											
ID	Acces Field	Value ID	Value	Description																									
		Disconnect	1	Disconnect input buffer																									
C	RW PULL			Pull configuration																									
		Disabled	0	No pull																									
		Pulldown	1	Pull down on pin																									
		Pullup	3	Pull up on pin																									
D	RW DRIVE			Drive configuration																									
		S0S1	0	Standard '0', standard '1'																									
		H0S1	1	High drive '0', standard '1'																									
		S0H1	2	Standard '0', high drive '1'																									
		H0H1	3	High drive '0', high 'drive '1''																									
		D0S1	4	Disconnect '0' standard '1' (normally used for wired-or connections)																									
		D0H1	5	Disconnect '0', high drive '1' (normally used for wired-or connections)																									
		S0D1	6	Standard '0'. disconnect '1' (normally used for wired-and connections)																									
		H0D1	7	High drive '0', disconnect '1' (normally used for wired-and connections)																									
E	RW SENSE			Pin sensing mechanism																									
		Disabled	0	Disabled																									
		High	2	Sense for high level																									
		Low	3	Sense for low level																									

6.8.3 Electrical specification

6.8.3.1 GPIO Electrical Specification

Symbol	Description	Min.	Typ.	Max.	Units
V_{IH}	Input high voltage	0.7 x VDD		VDD	V
V_{IL}	Input low voltage	VSS		0.3 x VDD	V
$V_{OH,SD}$	Output high voltage, standard drive, 0.5 mA, VDD \geq 1.7	VDD-0.4		VDD	V
$V_{OH,HDH}$	Output high voltage, high drive, 5 mA, VDD \geq 2.7 V	VDD-0.4		VDD	V
$V_{OH,HDL}$	Output high voltage, high drive, 3 mA, VDD \geq 1.7 V	VDD-0.4		VDD	V
$V_{OL,SD}$	Output low voltage, standard drive, 0.5 mA, VDD \geq 1.7	VSS		VSS+0.4	V
$V_{OL,HDH}$	Output low voltage, high drive, 5 mA, VDD \geq 2.7 V	VSS		VSS+0.4	V
$V_{OL,HDL}$	Output low voltage, high drive, 3 mA, VDD \geq 1.7 V	VSS		VSS+0.4	V
$I_{OL,SD}$	Current at VSS+0.4 V, output set low, standard drive, VDD \geq 1.7	1	2	4	mA
$I_{OL,HDH}$	Current at VSS+0.4 V, output set low, high drive, VDD \geq 2.7 V	6	10	15	mA
$I_{OL,HDL}$	Current at VSS+0.4 V, output set low, high drive, VDD \geq 1.7 V	3			mA
$I_{OH,SD}$	Current at VDD-0.4 V, output set high, standard drive, VDD \geq 1.7	1	2	4	mA
$I_{OH,HDH}$	Current at VDD-0.4 V, output set high, high drive, VDD \geq 2.7 V	6	9	14	mA

Symbol	Description	Min.	Typ.	Max.	Units
$I_{OH,HDL}$	Current at VDD-0.4 V, output set high, high drive, VDD \geq 1.7 V	3			mA
$t_{RF,15pF}$	Rise/fall time, standard drive mode, 10-90%, 15 pF load ¹		9		ns
$t_{RF,25pF}$	Rise/fall time, standard drive mode, 10-90%, 25 pF load ¹		13		ns
$t_{RF,50pF}$	Rise/fall time, standard drive mode, 10-90%, 50 pF load ¹		25		ns
$t_{HRF,15pF}$	Rise/Fall time, high drive mode, 10-90%, 15 pF load ¹		4		ns
$t_{HRF,25pF}$	Rise/Fall time, high drive mode, 10-90%, 25 pF load ¹		5		ns
$t_{HRF,50pF}$	Rise/Fall time, high drive mode, 10-90%, 50 pF load ¹		8		ns
R_{PU}	Pull-up resistance	11	13	16	k Ω
R_{PD}	Pull-down resistance	11	13	16	k Ω
C_{PAD}	Pad capacitance		3		pF

6.9 GPIOTE — GPIO tasks and events

The GPIOTE tasks and events (GPIOTE) module provides functionality for accessing GPIO pins using tasks and events. Each GPIOTE channel can be assigned to one pin.

A GPIOTE block enables GPIOs to generate events on pin state change which can be used to carry out tasks through the PPI system. A GPIO can also be driven to change state on system events using the PPI system. Low power detection of pin state changes is possible when in System ON or System OFF.

Instance	Number of GPIOTE channels
GPIOTE	8

Table 39: GPIOTE properties

Up to three tasks can be used in each GPIOTE channel for performing write operations to a pin. Two tasks are fixed (SET and CLR), and one (OUT) is configurable to perform following operations:

- Set
- Clear
- Toggle

An event can be generated in each GPIOTE channel from one of the following input conditions:

- Rising edge
- Falling edge
- Any change

6.9.1 Pin events and tasks

The GPIOTE module has a number of tasks and events that can be configured to operate on individual GPIO pins.

The tasks (SET[n], CLR[n] and OUT[n]) can be used for writing to individual pins, and the events (IN[n]) can be generated from changes occurring at the inputs of individual pins.

The SET task will set the pin selected in CONFIG[n].PSEL to high.

The CLR task will set the pin low.

The effect of the OUT task on the pin is configurable in CONFIG[n].POLARITY, and can either set the pin high, set it low, or toggle it.

¹ Rise and fall times based on simulations

The tasks and events are configured using the CONFIG[n] registers. Every set of SET, CLR and OUT[n] tasks and IN[n] events has one CONFIG[n] register associated with it.

As long as a SET[n], CLR[n] and OUT[n] task or an IN[n] event is configured to control a pin *n*, the pin's output value will only be updated by the GPIOTE module. The pin's output value as specified in the GPIO will therefore be ignored as long as the pin is controlled by GPIOTE. Attempting to write a pin as a normal GPIO pin will have no effect. When the GPIOTE is disconnected from a pin, see MODE field in CONFIG[n] register, the associated pin will get the output and configuration values specified in the GPIO module.

When conflicting tasks are triggered simultaneously (i.e. during the same clock cycle) in one channel, the precedence of the tasks will be as described in [Task priorities](#) on page 125.

Priority	Task
1	OUT
2	CLR
3	SET

Table 40: Task priorities

When setting the CONFIG[n] registers, MODE=Disabled does not have the same effect as MODE=Task and POLARITY=None. In the latter case, a CLR or SET task occurring at the exact same time as OUT will end up with no change on the pin, according to the priorities described in the table above.

When a GPIOTE channel is configured to operate on a pin as a task, the initial value of that pin is configured in the OUTINIT field of CONFIG[n].

6.9.2 Port event

PORT is an event that can be generated from multiple input pins using the GPIO DETECT signal.

The event will be generated on the rising edge of the DETECT signal. See [GPIO — General purpose input/output](#) on page 116 for more information about the DETECT signal.

Putting the system into System ON IDLE while DETECT is high will not cause DETECT to wake the system up again. Make sure to clear all DETECT sources before entering sleep. If the LATCH register is used as a source, if any bit in LATCH is still high after clearing all or part of the register (for instance due to one of the PINx.DETECT signal still high), a new rising edge will be generated on DETECT, see [Pin configuration](#) on page 117.

Trying to put the system to System OFF while DETECT is high will cause a wakeup from System OFF reset.

This feature is always enabled although the peripheral itself appears to be IDLE, that is, no clocks or other power intensive infrastructure have to be requested to keep this feature enabled. This feature can therefore be used to wake up the CPU from a WFI or WFE type sleep in System ON with all peripherals and the CPU idle, that is, lowest power consumption in System ON mode.

In order to prevent spurious interrupts from the PORT event while configuring the sources, the user shall first disable interrupts on the PORT event (through INTENCLR.PORT), then configure the sources (PIN_CNF[n].SENSE), clear any potential event that could have occurred during configuration (write '0' to EVENTS_PORT), and finally enable interrupts (through INTENSET.PORT).

6.9.3 Tasks and events pin configuration

Each GPIOTE channel is associated with one physical GPIO pin through the CONFIG.PSEL field.

When Event mode is selected in CONFIG.MODE, the pin specified by CONFIG.PSEL will be configured as an input, overriding the DIR setting in GPIO. Similarly, when Task mode is selected in CONFIG.MODE, the pin specified by CONFIG.PSEL will be configured as an output overriding the DIR setting and OUT value in GPIO. When Disabled is selected in CONFIG.MODE, the pin specified by CONFIG.PSEL will use its configuration from the PIN[n].CNF registers in GPIO.

Only one GPIOTE channel can be assigned to one physical pin. Failing to do so may result in unpredictable behavior.

6.9.4 Registers

Base address	Peripheral	Instance	Description	Configuration
0x40006000	GPIOTE	GPIOTE	GPIO tasks and events	

Table 41: Instances

Register	Offset	Description
TASKS_OUT[0]	0x000	Task for writing to pin specified in CONFIG[0].PSEL. Action on pin is configured in CONFIG[0].POLARITY.
TASKS_OUT[1]	0x004	Task for writing to pin specified in CONFIG[1].PSEL. Action on pin is configured in CONFIG[1].POLARITY.
TASKS_OUT[2]	0x008	Task for writing to pin specified in CONFIG[2].PSEL. Action on pin is configured in CONFIG[2].POLARITY.
TASKS_OUT[3]	0x00C	Task for writing to pin specified in CONFIG[3].PSEL. Action on pin is configured in CONFIG[3].POLARITY.
TASKS_OUT[4]	0x010	Task for writing to pin specified in CONFIG[4].PSEL. Action on pin is configured in CONFIG[4].POLARITY.
TASKS_OUT[5]	0x014	Task for writing to pin specified in CONFIG[5].PSEL. Action on pin is configured in CONFIG[5].POLARITY.
TASKS_OUT[6]	0x018	Task for writing to pin specified in CONFIG[6].PSEL. Action on pin is configured in CONFIG[6].POLARITY.
TASKS_OUT[7]	0x01C	Task for writing to pin specified in CONFIG[7].PSEL. Action on pin is configured in CONFIG[7].POLARITY.
TASKS_SET[0]	0x030	Task for writing to pin specified in CONFIG[0].PSEL. Action on pin is to set it high.
TASKS_SET[1]	0x034	Task for writing to pin specified in CONFIG[1].PSEL. Action on pin is to set it high.
TASKS_SET[2]	0x038	Task for writing to pin specified in CONFIG[2].PSEL. Action on pin is to set it high.
TASKS_SET[3]	0x03C	Task for writing to pin specified in CONFIG[3].PSEL. Action on pin is to set it high.
TASKS_SET[4]	0x040	Task for writing to pin specified in CONFIG[4].PSEL. Action on pin is to set it high.
TASKS_SET[5]	0x044	Task for writing to pin specified in CONFIG[5].PSEL. Action on pin is to set it high.
TASKS_SET[6]	0x048	Task for writing to pin specified in CONFIG[6].PSEL. Action on pin is to set it high.
TASKS_SET[7]	0x04C	Task for writing to pin specified in CONFIG[7].PSEL. Action on pin is to set it high.
TASKS_CLR[0]	0x060	Task for writing to pin specified in CONFIG[0].PSEL. Action on pin is to set it low.
TASKS_CLR[1]	0x064	Task for writing to pin specified in CONFIG[1].PSEL. Action on pin is to set it low.
TASKS_CLR[2]	0x068	Task for writing to pin specified in CONFIG[2].PSEL. Action on pin is to set it low.
TASKS_CLR[3]	0x06C	Task for writing to pin specified in CONFIG[3].PSEL. Action on pin is to set it low.
TASKS_CLR[4]	0x070	Task for writing to pin specified in CONFIG[4].PSEL. Action on pin is to set it low.
TASKS_CLR[5]	0x074	Task for writing to pin specified in CONFIG[5].PSEL. Action on pin is to set it low.
TASKS_CLR[6]	0x078	Task for writing to pin specified in CONFIG[6].PSEL. Action on pin is to set it low.
TASKS_CLR[7]	0x07C	Task for writing to pin specified in CONFIG[7].PSEL. Action on pin is to set it low.
EVENTS_IN[0]	0x100	Event generated from pin specified in CONFIG[0].PSEL
EVENTS_IN[1]	0x104	Event generated from pin specified in CONFIG[1].PSEL
EVENTS_IN[2]	0x108	Event generated from pin specified in CONFIG[2].PSEL
EVENTS_IN[3]	0x10C	Event generated from pin specified in CONFIG[3].PSEL
EVENTS_IN[4]	0x110	Event generated from pin specified in CONFIG[4].PSEL
EVENTS_IN[5]	0x114	Event generated from pin specified in CONFIG[5].PSEL
EVENTS_IN[6]	0x118	Event generated from pin specified in CONFIG[6].PSEL
EVENTS_IN[7]	0x11C	Event generated from pin specified in CONFIG[7].PSEL
EVENTS_PORT	0x17C	Event generated from multiple input GPIO pins with SENSE mechanism enabled
INTENSET	0x304	Enable interrupt

Register	Offset	Description
INTENCLR	0x308	Disable interrupt
CONFIG[0]	0x510	Configuration for OUT[n], SET[n] and CLR[n] tasks and IN[n] event
CONFIG[1]	0x514	Configuration for OUT[n], SET[n] and CLR[n] tasks and IN[n] event
CONFIG[2]	0x518	Configuration for OUT[n], SET[n] and CLR[n] tasks and IN[n] event
CONFIG[3]	0x51C	Configuration for OUT[n], SET[n] and CLR[n] tasks and IN[n] event
CONFIG[4]	0x520	Configuration for OUT[n], SET[n] and CLR[n] tasks and IN[n] event
CONFIG[5]	0x524	Configuration for OUT[n], SET[n] and CLR[n] tasks and IN[n] event
CONFIG[6]	0x528	Configuration for OUT[n], SET[n] and CLR[n] tasks and IN[n] event
CONFIG[7]	0x52C	Configuration for OUT[n], SET[n] and CLR[n] tasks and IN[n] event

Table 42: Register overview

6.9.4.1 TASKS_OUT[n] (n=0..7)

Address offset: $0x000 + (n \times 0x4)$

Task for writing to pin specified in CONFIG[n].PSEL. Action on pin is configured in CONFIG[n].POLARITY.

Bit number	31 30 29 28 27 26 25 24 23 22 21 20 19 18 17 16 15 14 13 12 11 10 9 8 7 6 5 4 3 2 1 0																															
ID																																A
Reset 0x00000000	0 0																															
ID	Acce Field	Value ID	Value	Description																												
A	W TASKS_OUT			Task for writing to pin specified in CONFIG[n].PSEL. Action on pin is configured in CONFIG[n].POLARITY.																												
		Trigger	1	Trigger task																												

6.9.4.2 TASKS_SET[n] (n=0..7)

Address offset: $0x030 + (n \times 0x4)$

Task for writing to pin specified in CONFIG[n].PSEL. Action on pin is to set it high.

Bit number	31 30 29 28 27 26 25 24 23 22 21 20 19 18 17 16 15 14 13 12 11 10 9 8 7 6 5 4 3 2 1 0																															
ID																																A
Reset 0x00000000	0 0																															
ID	Acce Field	Value ID	Value	Description																												
A	W TASKS_SET			Task for writing to pin specified in CONFIG[n].PSEL. Action on pin is to set it high.																												
		Trigger	1	Trigger task																												

6.9.4.3 TASKS_CLR[n] (n=0..7)

Address offset: $0x060 + (n \times 0x4)$

Task for writing to pin specified in CONFIG[n].PSEL. Action on pin is to set it low.

Bit number	31 30 29 28 27 26 25 24 23 22 21 20 19 18 17 16 15 14 13 12 11 10 9 8 7 6 5 4 3 2 1 0																															
ID																																A
Reset 0x00000000	0 0																															
ID	Acce Field	Value ID	Value	Description																												
A	W TASKS_CLR			Task for writing to pin specified in CONFIG[n].PSEL. Action on pin is to set it low.																												
		Trigger	1	Trigger task																												

6.9.4.4 EVENTS_IN[n] (n=0..7)

Address offset: 0x100 + (n × 0x4)

Event generated from pin specified in CONFIG[n].PSEL

Bit number	31 30 29 28 27 26 25 24 23 22 21 20 19 18 17 16 15 14 13 12 11 10 9 8 7 6 5 4 3 2 1 0																														
ID	A																														
Reset 0x00000000	0 0																														
ID	Acce Field	Value ID	Value	Description																											
A	RW	EVENTS_IN		Event generated from pin specified in CONFIG[n].PSEL																											
		NotGenerated	0	Event not generated																											
		Generated	1	Event generated																											

6.9.4.5 EVENTS_PORT

Address offset: 0x17C

Event generated from multiple input GPIO pins with SENSE mechanism enabled

Bit number	31 30 29 28 27 26 25 24 23 22 21 20 19 18 17 16 15 14 13 12 11 10 9 8 7 6 5 4 3 2 1 0																														
ID	A																														
Reset 0x00000000	0 0																														
ID	Acce Field	Value ID	Value	Description																											
A	RW	EVENTS_PORT		Event generated from multiple input GPIO pins with SENSE mechanism enabled																											
		NotGenerated	0	Event not generated																											
		Generated	1	Event generated																											

6.9.4.6 INTENSET

Address offset: 0x304

Enable interrupt

Bit number	31 30 29 28 27 26 25 24 23 22 21 20 19 18 17 16 15 14 13 12 11 10 9 8 7 6 5 4 3 2 1 0																														
ID	I															H G F E D C B A															
Reset 0x00000000	0 0																														
ID	Acce Field	Value ID	Value	Description																											
A-H	RW	IN[i] (i=0..7)		Write '1' to enable interrupt for event IN[i]																											
		Set	1	Enable																											
		Disabled	0	Read: Disabled																											
		Enabled	1	Read: Enabled																											
I	RW	PORT		Write '1' to enable interrupt for event PORT																											
		Set	1	Enable																											
		Disabled	0	Read: Disabled																											
		Enabled	1	Read: Enabled																											

6.9.4.7 INTENCLR

Address offset: 0x308

Disable interrupt

Bit number	31	30	29	28	27	26	25	24	23	22	21	20	19	18	17	16	15	14	13	12	11	10	9	8	7	6	5	4	3	2	1	0
ID	I																H G F E D C B A															
Reset 0x00000000	0 0																															
ID	Acce Field	Value ID	Value	Description																												
A-H	RW IN[i] (i=0..7)			Write '1' to disable interrupt for event IN[i]																												
		Clear	1	Disable																												
		Disabled	0	Read: Disabled																												
		Enabled	1	Read: Enabled																												
I	RW PORT			Write '1' to disable interrupt for event PORT																												
		Clear	1	Disable																												
		Disabled	0	Read: Disabled																												
		Enabled	1	Read: Enabled																												

6.9.4.8 CONFIG[n] (n=0..7)

Address offset: 0x510 + (n × 0x4)

Configuration for OUT[n], SET[n] and CLR[n] tasks and IN[n] event

Bit number	31	30	29	28	27	26	25	24	23	22	21	20	19	18	17	16	15	14	13	12	11	10	9	8	7	6	5	4	3	2	1	0
ID																	E			D D		B B B B B				A A						
Reset 0x00000000	0 0																															
ID	Acce Field	Value ID	Value	Description																												
A	RW MODE			Mode																												
		Disabled	0	Disabled. Pin specified by PSEL will not be acquired by the GPIOTE module.																												
		Event	1	Event mode The pin specified by PSEL will be configured as an input and the IN[n] event will be generated if operation specified in POLARITY occurs on the pin.																												
		Task	3	Task mode The GPIO specified by PSEL will be configured as an output and triggering the SET[n], CLR[n] or OUT[n] task will perform the operation specified by POLARITY on the pin. When enabled as a task the GPIOTE module will acquire the pin and the pin can no longer be written as a regular output pin from the GPIO module.																												
B	RW PSEL		[0..31]	GPIO number associated with SET[n], CLR[n] and OUT[n] tasks and IN[n] event																												
D	RW POLARITY			When In task mode: Operation to be performed on output when OUT[n] task is triggered. When In event mode: Operation on input that shall trigger IN[n] event.																												
		None	0	Task mode: No effect on pin from OUT[n] task. Event mode: no IN[n] event generated on pin activity.																												
		LoToHi	1	Task mode: Set pin from OUT[n] task. Event mode: Generate IN[n] event when rising edge on pin.																												
		HiToLo	2	Task mode: Clear pin from OUT[n] task. Event mode: Generate IN[n] event when falling edge on pin.																												
		Toggle	3	Task mode: Toggle pin from OUT[n]. Event mode: Generate IN[n] when any change on pin.																												
E	RW OUTINIT			When in task mode: Initial value of the output when the GPIOTE channel is configured. When in event mode: No effect.																												
		Low	0	Task mode: Initial value of pin before task triggering is low																												

Bit number	31	30	29	28	27	26	25	24	23	22	21	20	19	18	17	16	15	14	13	12	11	10	9	8	7	6	5	4	3	2	1	0
ID												E	D	D	B					B	B	B	B	A					A			
Reset 0x00000000	0																															
ID	Acce Field	Value ID	Value	Description																												
		High	1	Task mode: Initial value of pin before task triggering is high																												

6.9.5 Electrical specification

6.10 PDM — Pulse density modulation interface

The pulse density modulation (PDM) module enables input of pulse density modulated signals from external audio frontends, for example, digital microphones. The PDM module generates the PDM clock and supports single-channel or dual-channel (Left and Right) data input. Data is transferred directly to RAM buffers using EasyDMA.

Listed here are the main features for PDM:

- Up to two PDM microphones configured as a Left/Right pair using the same data input
- 16 kHz output sample rate, 16-bit samples
- EasyDMA support for sample buffering
- HW decimation filters

The PDM module illustrated in [PDM module](#) on page 130 is interfacing up to two digital microphones with the PDM interface. It implements EasyDMA, which relieves real-time requirements associated with controlling the PDM slave from a low priority CPU execution context. It also includes all the necessary digital filter elements to produce PCM samples. The PDM module allows continuous audio streaming.

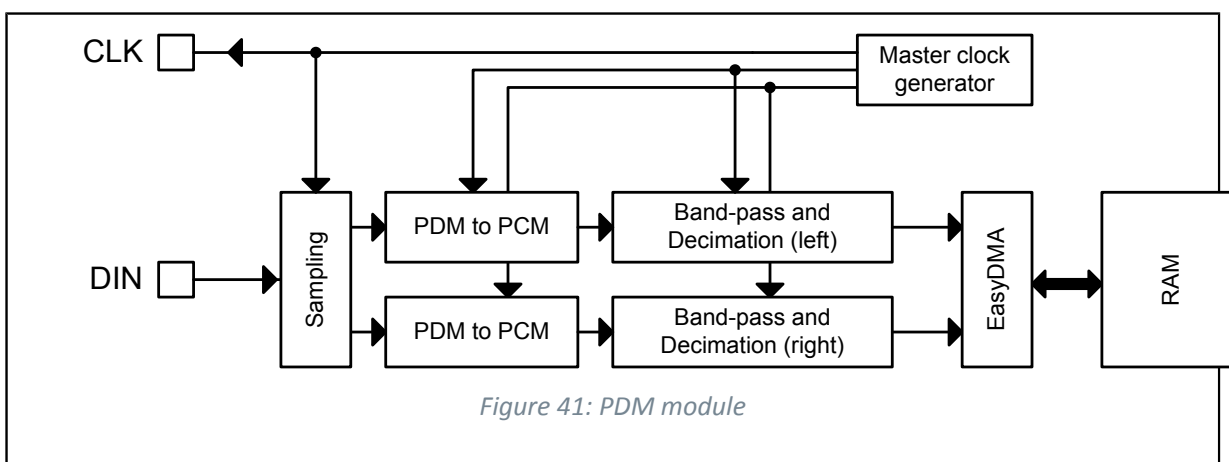

Figure 41: PDM module

6.10.1 Master clock generator

The `FREQ` field in the master clock's `PDMCLKCTRL` register allows adjusting the PDM clock's frequency.

The master clock generator does not add any jitter to the `HFCLK` source chosen. It is recommended (but not mandatory) to use the `Xtal` as `HFCLK` source.

6.10.2 Module operation

By default, bits from the left PDM microphone are sampled on `PDM_CLK` falling edge, bits for the right are sampled on the rising edge of `PDM_CLK`, resulting in two bitstreams. Each bitstream is fed into a digital filter which converts the PDM stream into 16-bit PCM samples, and filters and down-samples them to reach the appropriate sample rate.

The EDGE field in the MODE register allows swapping Left and Right, so that Left will be sampled on rising edge, and Right on falling.

The PDM module uses EasyDMA to store the samples coming out from the filters into one buffer in RAM.

Depending on the mode chosen in the OPERATION field in the MODE register, memory either contains alternating left and right 16-bit samples (Stereo), or only left 16-bit samples (Mono).

To ensure continuous PDM sampling, it is up to the application to update the EasyDMA destination address pointer as the previous buffer is filled.

The continuous transfer can be started or stopped by sending the START and STOP tasks. STOP becomes effective after the current frame has finished transferring, which will generate the STOPPED event. The STOPPED event indicates that all activity in the module are finished, and that the data is available in RAM (EasyDMA has finished transferring as well). Attempting to restart before receiving the STOPPED event may result in unpredictable behaviour.

6.10.3 Decimation filter

In order to convert the incoming data stream into PCM audio samples, a decimation filter is included in the PDM interface module.

The input of the filter is the two-channel PDM serial stream (with left channel on clock high, right channel on clock low), its output is 2×16 -bit PCM samples at a sample rate 64 times lower than the PDM clock rate.

The filter stage of each channel is followed by a digital volume control, to attenuate or amplify the output samples in a range of -20 dB to +20 dB around the default (reset) setting, defined by $G_{\text{PDM,default}}$. The gain is controlled by the GAINL and GAINR registers.

As an example, if the goal is to achieve 2500 RMS output samples (16 bit) with a 1 kHz 90 dBA signal into a -26 dBFS sensitivity PDM microphone, the user will have to sum the PDM module's default gain ($G_{\text{PDM,default}}$) and the gain introduced by the microphone and acoustic path of his implementation (an attenuation would translate into a negative gain), and adjust GAINL and GAINR by this amount. Assuming that only the PDM module influences the gain, GAINL and GAINR must be set to $-G_{\text{PDM,default}}$ dB to achieve the requirement.

With $G_{\text{PDM,default}}=3.2$ dB, and as GAINL and GAINR are expressed in 0.5 dB steps, the closest value to program would be 3.0 dB, which can be calculated as:

$$\text{GAINL} = \text{GAINR} = (\text{DefaultGain} - (2 * 3))$$

Remember to check that the resulting values programmed into GAINL and GAINR fall within MinGain and MaxGain.

6.10.4 EasyDMA

Samples will be written directly to RAM, and EasyDMA must be configured accordingly.

The address pointer for the EasyDMA channel is set in SAMPLE.PTR register. If the destination address set in SAMPLE.PTR is not pointing to the Data RAM region, an EasyDMA transfer may result in a HardFault or RAM corruption. See [Memory](#) on page 17 for more information about the different memory regions.

DMA supports Stereo (Left+Right 16-bit samples) and Mono (Left only) data transfer, depending on setting in the OPERATION field in the MODE register. The samples are stored little endian.

MODE.OPERATION	Bits per sample	Result stored per RAM word	Physical RAM allocated (32 bit words)	Result boundary indexes in RAM	Note
Stereo	32 (2x16)	L+R	$\text{ceil}(\text{SAMPLE.MAXCNT}/2)$	R0=[31:16]; L0=[15:0]	Default
Mono	16	2xL	$\text{ceil}(\text{SAMPLE.MAXCNT}/2)$	L1=[31:16]; L0=[15:0]	

Table 43: DMA sample storage

The destination buffer in RAM consists of one block, the size of which is set in SAMPLE.MAXCNT register. Format is number of 16-bit samples. The physical RAM allocated is always:

```
(RAM allocation, in bytes) = SAMPLE.MAXCNT * 2;
```

(but the mapping of the samples depends on MODE.OPERATION.

If OPERATION=Stereo, RAM will contain a succession of Left and Right samples.

If OPERATION=Mono, RAM will contain a succession of mono samples.

For a given value of SAMPLE.MAXCNT, the buffer in RAM can contain half the stereo sampling time as compared to the mono sampling time.

The PDM acquisition can be started by the START task, after the SAMPLE.PTR and SAMPLE.MAXCNT registers have been written. When starting the module, it will take some time for the filters to start outputting valid data. Transients from the PDM microphone itself may also occur. The first few samples (typically around 50) might hence contain invalid values or transients. It is therefore advised to discard the first few samples after a PDM start.

As soon as the STARTED event is received, the firmware can write the next SAMPLE.PTR value (this register is double-buffered), to ensure continuous operation.

When the buffer in RAM is filled with samples, an END event is triggered. The firmware can start processing the data in the buffer. Meanwhile, the PDM module starts acquiring data into the new buffer pointed to by SAMPLE.PTR, and sends a new STARTED event, so that the firmware can update SAMPLE.PTR to the next buffer address.

6.10.5 Hardware example

Connect the microphone clock to CLK, and data to DIN.

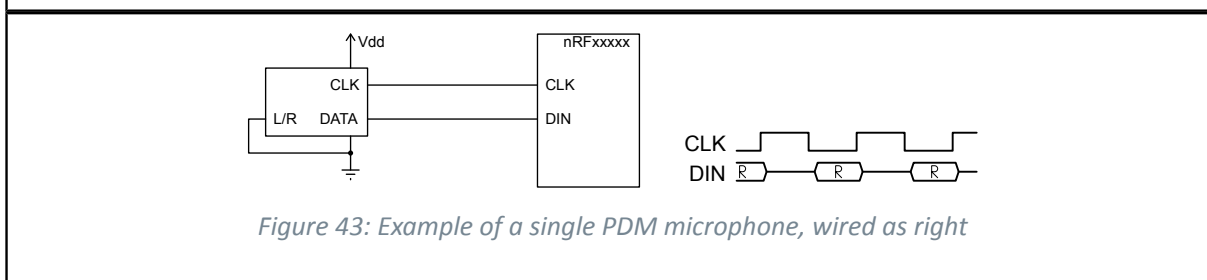
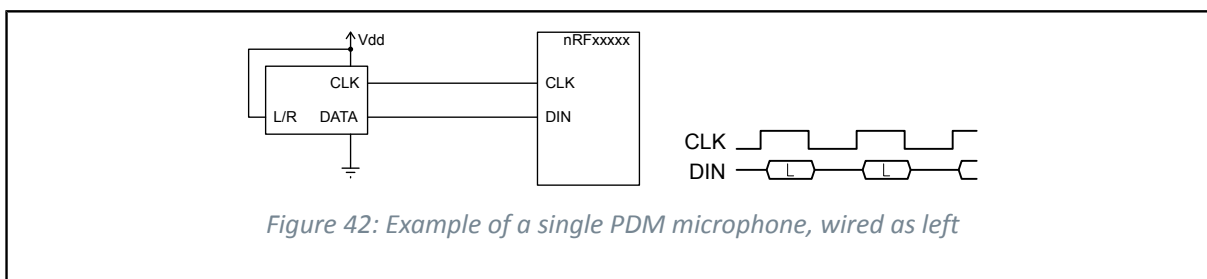

Note that in a single-microphone (mono) configuration, depending on the microphone's implementation, either the left or the right channel (sampled at falling or rising CLK edge respectively) will contain reliable data. If two microphones are used, one of them has to be set as left, the other as right (L/R pin tied high or to GND on the respective microphone). It is strongly recommended to use two microphones of exactly the same brand and type so that their timings in left and right operation match.

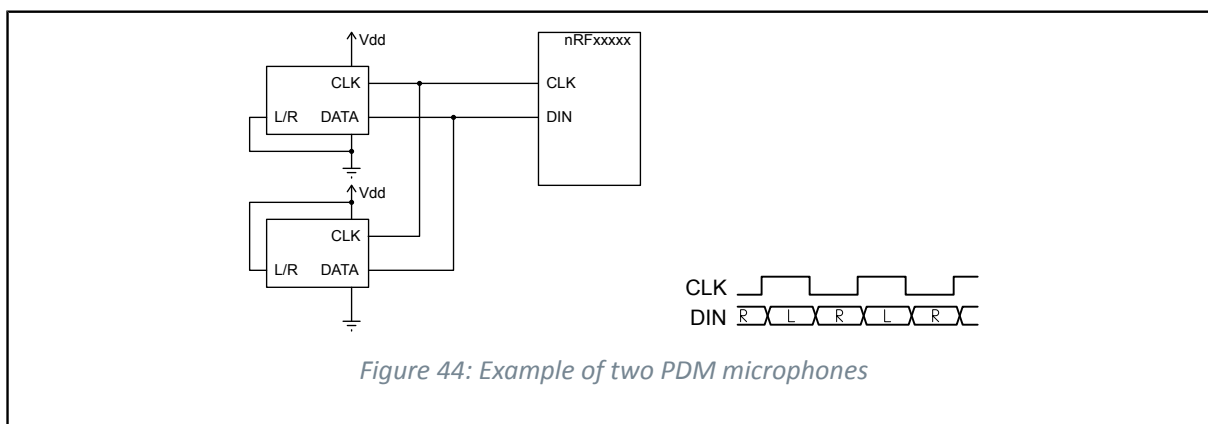

6.10.6 Pin configuration

The CLK and DIN signals associated to the PDM module are mapped to physical pins according to the configuration specified in the PSEL.CLK and PSEL.DIN registers respectively. If the CONNECT field in any PSEL register is set to Disconnected, the associated PDM module signal will not be connected to the required physical pins, and will not operate properly.

The PSEL.CLK and PSEL.DIN registers and their configurations are only used as long as the PDM module is enabled, and retained only as long as the device is in System ON mode. See [POWER — Power supply](#) on page 49 for more information about power modes. When the peripheral is disabled, the pins will behave as regular GPIOs, and use the configuration in their respective OUT bit field and PIN_CNF[n] register.

To ensure correct behaviour in the PDM module, the pins used by the PDM module must be configured in the GPIO peripheral as described in [GPIO configuration before enabling peripheral](#) on page 133 before enabling the PDM module. This is to ensure that the pins used by the PDM module are driven correctly if the PDM module itself is temporarily disabled or the device temporarily enters System OFF. This configuration must be retained in the GPIO for the selected I/Os as long as the PDM module is supposed to be connected to an external PDM circuit.

Only one peripheral can be assigned to drive a particular GPIO pin at a time. Failing to do so may result in unpredictable behaviour.

PDM signal	PDM pin	Direction	Output value	Comment
CLK	As specified in PSEL.CLK	Output	0	
DIN	As specified in PSEL.DIN	Input	Not applicable	

Table 44: GPIO configuration before enabling peripheral

6.10.7 Registers

Base address	Peripheral	Instance	Description	Configuration
0x4001D000	PDM	PDM	Pulse-density modulation (digital microphone interface)	

Table 45: Instances

Register	Offset	Description
TASKS_START	0x000	Starts continuous PDM transfer
TASKS_STOP	0x004	Stops PDM transfer
EVENTS_STARTED	0x100	PDM transfer has started
EVENTS_STOPPED	0x104	PDM transfer has finished
EVENTS_END	0x108	The PDM has written the last sample specified by SAMPLE.MAXCNT (or the last sample after a STOP task has been received) to Data RAM
INTEN	0x300	Enable or disable interrupt
INTENSET	0x304	Enable interrupt
INTENCLR	0x308	Disable interrupt
ENABLE	0x500	PDM module enable register
PDMCLKCTRL	0x504	PDM clock generator control
MODE	0x508	Defines the routing of the connected PDM microphones' signals
GAINL	0x518	Left output gain adjustment
GAINR	0x51C	Right output gain adjustment
PSEL.CLK	0x540	Pin number configuration for PDM CLK signal
PSEL.DIN	0x544	Pin number configuration for PDM DIN signal
SAMPLE.PTR	0x560	RAM address pointer to write samples to with EasyDMA
SAMPLE.MAXCNT	0x564	Number of samples to allocate memory for in EasyDMA mode

Table 46: Register overview

6.10.7.1 TASKS_START

Address offset: 0x000

Starts continuous PDM transfer

Bit number	31 30 29 28 27 26 25 24 23 22 21 20 19 18 17 16 15 14 13 12 11 10 9 8 7 6 5 4 3 2 1 0																														
ID	A																														
Reset 0x00000000	0 0																														
ID	Acce	Field	Value	ID	Value	Description																									
A	W	TASKS_START				Starts continuous PDM transfer																									
			Trigger		1	Trigger task																									

6.10.7.2 TASKS_STOP

Address offset: 0x004

Stops PDM transfer

Bit number	31 30 29 28 27 26 25 24 23 22 21 20 19 18 17 16 15 14 13 12 11 10 9 8 7 6 5 4 3 2 1 0																														
ID	A																														
Reset 0x00000000	0 0																														
ID	Acce	Field	Value	ID	Value	Description																									
A	W	TASKS_STOP				Stops PDM transfer																									
			Trigger		1	Trigger task																									

6.10.7.3 EVENTS_STARTED

Address offset: 0x100

PDM transfer has started

Bit number	31	30	29	28	27	26	25	24	23	22	21	20	19	18	17	16	15	14	13	12	11	10	9	8	7	6	5	4	3	2	1	0	
ID																																A	
Reset	0x00000000																																
0	0	0	0	0	0	0	0	0	0	0	0	0	0	0	0	0	0	0	0	0	0	0	0	0	0	0	0	0	0	0	0	0	0
ID	Acce Field	Value ID	Value	Description																													
A	RW	EVENTS_STARTED		PDM transfer has started																													
		NotGenerated	0	Event not generated																													
		Generated	1	Event generated																													

6.10.7.4 EVENTS_STOPPED

Address offset: 0x104

PDM transfer has finished

Bit number	31	30	29	28	27	26	25	24	23	22	21	20	19	18	17	16	15	14	13	12	11	10	9	8	7	6	5	4	3	2	1	0
ID																																A
Reset	0x00000000																															
0	0	0	0	0	0	0	0	0	0	0	0	0	0	0	0	0	0	0	0	0	0	0	0	0	0	0	0	0	0	0	0	0
ID	Acce Field	Value ID	Value	Description																												
A	RW	EVENTS_STOPPED		PDM transfer has finished																												
		NotGenerated	0	Event not generated																												
		Generated	1	Event generated																												

6.10.7.5 EVENTS_END

Address offset: 0x108

The PDM has written the last sample specified by SAMPLE.MAXCNT (or the last sample after a STOP task has been received) to Data RAM

Bit number	31	30	29	28	27	26	25	24	23	22	21	20	19	18	17	16	15	14	13	12	11	10	9	8	7	6	5	4	3	2	1	0
ID																																A
Reset	0x00000000																															
0	0	0	0	0	0	0	0	0	0	0	0	0	0	0	0	0	0	0	0	0	0	0	0	0	0	0	0	0	0	0	0	0
ID	Acce Field	Value ID	Value	Description																												
A	RW	EVENTS_END		The PDM has written the last sample specified by SAMPLE.MAXCNT (or the last sample after a STOP task has been received) to Data RAM																												
		NotGenerated	0	Event not generated																												
		Generated	1	Event generated																												

6.10.7.6 INTEN

Address offset: 0x300

Enable or disable interrupt

Bit number	31	30	29	28	27	26	25	24	23	22	21	20	19	18	17	16	15	14	13	12	11	10	9	8	7	6	5	4	3	2	1	0
ID																																C B A
Reset	0x00000000																															
0	0	0	0	0	0	0	0	0	0	0	0	0	0	0	0	0	0	0	0	0	0	0	0	0	0	0	0	0	0	0	0	0
ID	Acce Field	Value ID	Value	Description																												
A	RW	STARTED		Enable or disable interrupt for event STARTED																												
		Disabled	0	Disable																												
		Enabled	1	Enable																												
B	RW	STOPPED		Enable or disable interrupt for event STOPPED																												
		Disabled	0	Disable																												
		Enabled	1	Enable																												

Bit number	31	30	29	28	27	26	25	24	23	22	21	20	19	18	17	16	15	14	13	12	11	10	9	8	7	6	5	4	3	2	1	0
ID																												C	B	A		
Reset 0x00000000	0	0	0	0	0	0	0	0	0	0	0	0	0	0	0	0	0	0	0	0	0	0	0	0	0	0	0	0	0	0	0	
ID	Acce Field	Value ID	Value	Description																												
C	RW END			Enable or disable interrupt for event END																												
		Disabled	0	Disable																												
		Enabled	1	Enable																												

6.10.7.7 INTENSET

Address offset: 0x304

Enable interrupt

Bit number	31	30	29	28	27	26	25	24	23	22	21	20	19	18	17	16	15	14	13	12	11	10	9	8	7	6	5	4	3	2	1	0
ID																												C	B	A		
Reset 0x00000000	0	0	0	0	0	0	0	0	0	0	0	0	0	0	0	0	0	0	0	0	0	0	0	0	0	0	0	0	0	0	0	
ID	Acce Field	Value ID	Value	Description																												
A	RW STARTED			Write '1' to enable interrupt for event STARTED																												
		Set	1	Enable																												
		Disabled	0	Read: Disabled																												
		Enabled	1	Read: Enabled																												
B	RW STOPPED			Write '1' to enable interrupt for event STOPPED																												
		Set	1	Enable																												
		Disabled	0	Read: Disabled																												
		Enabled	1	Read: Enabled																												
C	RW END			Write '1' to enable interrupt for event END																												
		Set	1	Enable																												
		Disabled	0	Read: Disabled																												
		Enabled	1	Read: Enabled																												

6.10.7.8 INTENCLR

Address offset: 0x308

Disable interrupt

Bit number	31	30	29	28	27	26	25	24	23	22	21	20	19	18	17	16	15	14	13	12	11	10	9	8	7	6	5	4	3	2	1	0
ID																												C	B	A		
Reset 0x00000000	0	0	0	0	0	0	0	0	0	0	0	0	0	0	0	0	0	0	0	0	0	0	0	0	0	0	0	0	0	0	0	
ID	Acce Field	Value ID	Value	Description																												
A	RW STARTED			Write '1' to disable interrupt for event STARTED																												
		Clear	1	Disable																												
		Disabled	0	Read: Disabled																												
		Enabled	1	Read: Enabled																												
B	RW STOPPED			Write '1' to disable interrupt for event STOPPED																												
		Clear	1	Disable																												
		Disabled	0	Read: Disabled																												
		Enabled	1	Read: Enabled																												
C	RW END			Write '1' to disable interrupt for event END																												
		Clear	1	Disable																												
		Disabled	0	Read: Disabled																												
		Enabled	1	Read: Enabled																												

6.10.7.9 ENABLE

Address offset: 0x500

PDM module enable register

Bit number	31 30 29 28 27 26 25 24 23 22 21 20 19 18 17 16 15 14 13 12 11 10 9 8 7 6 5 4 3 2 1 0																														
ID	A																														
Reset 0x00000000	0 0																														
ID	Acce Field	Value ID	Value	Description																											
A	RW ENABLE			Enable or disable PDM module																											
		Disabled	0	Disable																											
		Enabled	1	Enable																											

6.10.7.10 PDMCLKCTRL

Address offset: 0x504

PDM clock generator control

Bit number	31 30 29 28 27 26 25 24 23 22 21 20 19 18 17 16 15 14 13 12 11 10 9 8 7 6 5 4 3 2 1 0																														
ID	A A																														
Reset 0x08400000	0 0 0 0 1 0 0 0 0 1 0																														
ID	Acce Field	Value ID	Value	Description																											
A	RW FREQ			PDM_CLK frequency																											
		1000K	0x08000000	PDM_CLK = 32 MHz / 32 = 1.000 MHz																											
		Default	0x08400000	PDM_CLK = 32 MHz / 31 = 1.032 MHz																											
		1067K	0x08800000	PDM_CLK = 32 MHz / 30 = 1.067 MHz																											

6.10.7.11 MODE

Address offset: 0x508

Defines the routing of the connected PDM microphones' signals

Bit number	31 30 29 28 27 26 25 24 23 22 21 20 19 18 17 16 15 14 13 12 11 10 9 8 7 6 5 4 3 2 1 0																														
ID	B A																														
Reset 0x00000000	0 0																														
ID	Acce Field	Value ID	Value	Description																											
A	RW OPERATION			Mono or stereo operation																											
		Stereo	0	Sample and store one pair (Left + Right) of 16bit samples per RAM word R=[31:16]; L=[15:0]																											
		Mono	1	Sample and store two successive Left samples (16 bit each) per RAM word L1=[31:16]; L0=[15:0]																											
B	RW EDGE			Defines on which PDM_CLK edge Left (or mono) is sampled																											
		LeftFalling	0	Left (or mono) is sampled on falling edge of PDM_CLK																											
		LeftRising	1	Left (or mono) is sampled on rising edge of PDM_CLK																											

6.10.7.12 GAINL

Address offset: 0x518

Left output gain adjustment

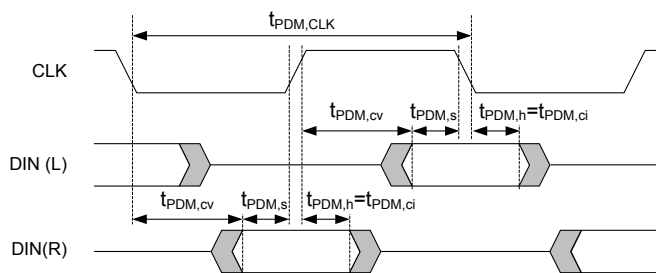

Figure 45: PDM timing diagram

6.11 PPI — Programmable peripheral interconnect

The programmable peripheral interconnect (PPI) enables peripherals to interact autonomously with each other using tasks and events independent of the CPU. The PPI allows precise synchronization between peripherals when real-time application constraints exist and eliminates the need for CPU activity to implement behavior which can be predefined using PPI.

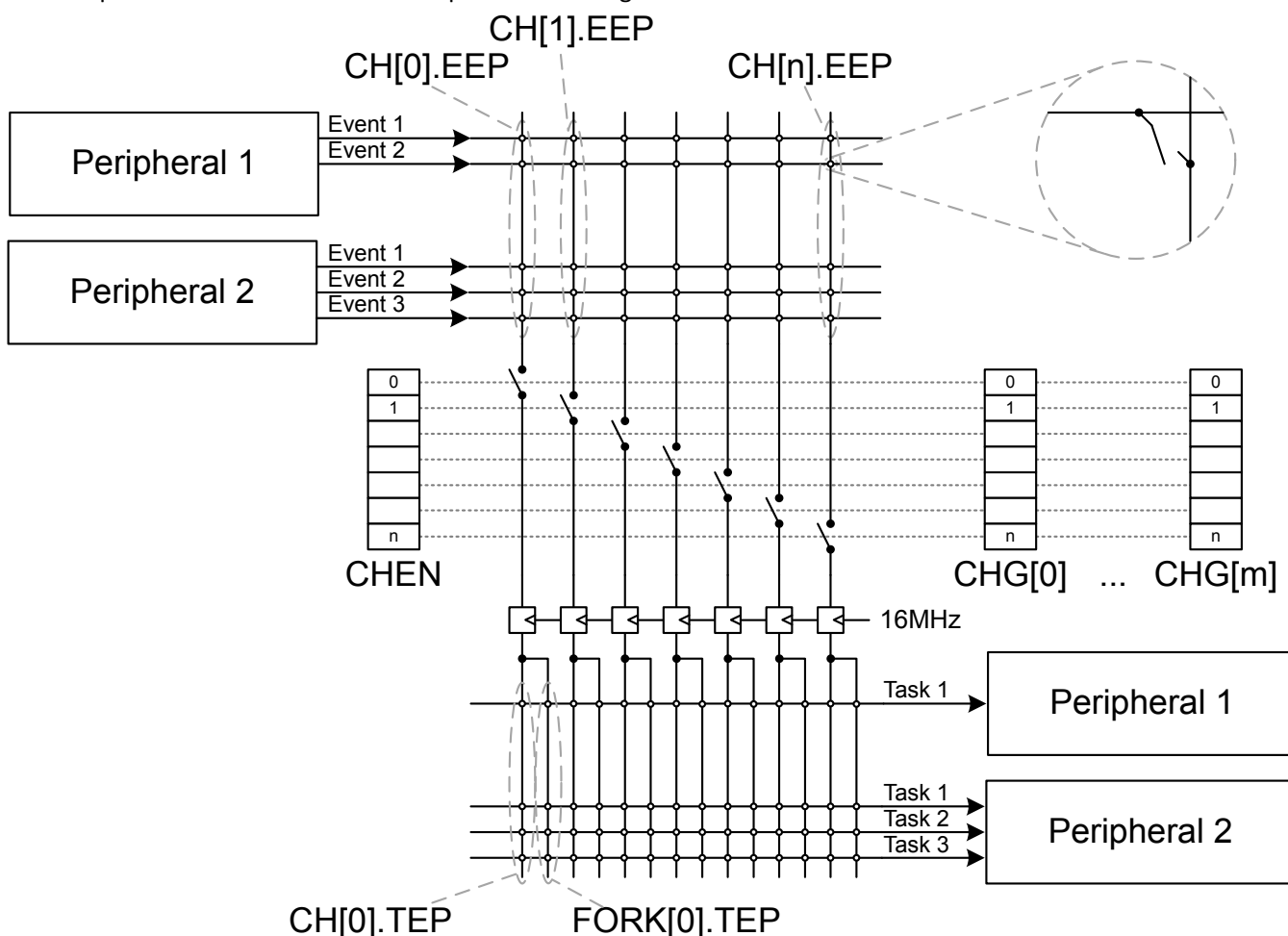

Figure 46: PPI block diagram

The PPI system has, in addition to the fully programmable peripheral interconnections, a set of channels where the event end point (EEP) and task end points (TEP) are fixed in hardware. These fixed channels can be individually enabled, disabled, or added to PPI channel groups (see CHG[n] registers), in the same way as ordinary PPI channels.

Instance	Channel	Number of channels
PPI	0-19	20
PPI (fixed)	20-31	12

Table 47: Configurable and fixed PPI channels

The PPI provides a mechanism to automatically trigger a task in one peripheral as a result of an event occurring in another peripheral. A task is connected to an event through a PPI channel. The PPI channel is composed of three end point registers, one EEP and two TEPs. A peripheral task is connected to a TEP using the address of the task register associated with the task. Similarly, a peripheral event is connected to an EEP using the address of the event register associated with the event.

On each PPI channel, the signals are synchronized to the 16 MHz clock, to avoid any internal violation of setup and hold timings. As a consequence, events that are synchronous to the 16 MHz clock will be delayed by one clock period, while other asynchronous events will be delayed by up to one 16 MHz clock period.

Note that shortcuts (as defined in the SHORTS register in each peripheral) are not affected by this 16 MHz synchronization, and are therefore not delayed.

Each TEP implements a fork mechanism that enables a second task to be triggered at the same time as the task specified in the TEP is triggered. This second task is configured in the task end point register in the FORK registers groups, e.g. FORK.TEP[0] is associated with PPI channel CH[0].

There are two ways of enabling and disabling PPI channels:

- Enable or disable PPI channels individually using the CHEN, CHENSET, and CHENCLR registers.
- Enable or disable PPI channels in PPI channel groups through the groups' ENABLE and DISABLE tasks. Prior to these tasks being triggered, the PPI channel group must be configured to define which PPI channels belong to which groups.

Note that when a channel belongs to two groups m and n, and the tasks CHG[m].EN and CHG[n].DIS occur simultaneously (m and n can be equal or different), the CHG[m].EN on that channel has priority.

PPI tasks (for example, CHG[0].EN) can be triggered through the PPI like any other task, which means they can be hooked to a PPI channel as a TEP. One event can trigger multiple tasks by using multiple channels and one task can be triggered by multiple events in the same way.

6.11.1 Pre-programmed channels

Some of the PPI channels are pre-programmed. These channels cannot be configured by the CPU, but can be added to groups and enabled and disabled like the general purpose PPI channels. The FORK TEP for these channels are still programmable and can be used by the application.

For a list of pre-programmed PPI channels, see the table below.

Channel	EEP	TEP
20	TIMER0->EVENTS_COMPARE[0]	RADIO->TASKS_TXEN
21	TIMER0->EVENTS_COMPARE[0]	RADIO->TASKS_RXEN
22	TIMER0->EVENTS_COMPARE[1]	RADIO->TASKS_DISABLE
23	RADIO->EVENTS_BCMATCH	AAR->TASKS_START
24	RADIO->EVENTS_READY	CCM->TASKS_KSGEN
25	RADIO->EVENTS_ADDRESS	CCM->TASKS_CRYPT
26	RADIO->EVENTS_ADDRESS	TIMER0->TASKS_CAPTURE[1]
27	RADIO->EVENTS_END	TIMER0->TASKS_CAPTURE[2]
28	RTC0->EVENTS_COMPARE[0]	RADIO->TASKS_TXEN
29	RTC0->EVENTS_COMPARE[0]	RADIO->TASKS_RXEN
30	RTC0->EVENTS_COMPARE[0]	TIMER0->TASKS_CLEAR
31	RTC0->EVENTS_COMPARE[0]	TIMER0->TASKS_START

Table 48: Pre-programmed channels

6.11.2 Registers

Base address	Peripheral	Instance	Description	Configuration
0x4001F000	PPI	PPI	Programmable peripheral interconnect	

Table 49: Instances

Register	Offset	Description
TASKS_CHG[0].EN	0x000	Enable channel group 0
TASKS_CHG[0].DIS	0x004	Disable channel group 0
TASKS_CHG[1].EN	0x008	Enable channel group 1
TASKS_CHG[1].DIS	0x00C	Disable channel group 1
TASKS_CHG[2].EN	0x010	Enable channel group 2
TASKS_CHG[2].DIS	0x014	Disable channel group 2
TASKS_CHG[3].EN	0x018	Enable channel group 3
TASKS_CHG[3].DIS	0x01C	Disable channel group 3
TASKS_CHG[4].EN	0x020	Enable channel group 4
TASKS_CHG[4].DIS	0x024	Disable channel group 4
TASKS_CHG[5].EN	0x028	Enable channel group 5
TASKS_CHG[5].DIS	0x02C	Disable channel group 5
CHEN	0x500	Channel enable register
CHENSET	0x504	Channel enable set register
CHENCLR	0x508	Channel enable clear register
CH[0].EEP	0x510	Channel 0 event end-point
CH[0].TEP	0x514	Channel 0 task end-point
CH[1].EEP	0x518	Channel 1 event end-point
CH[1].TEP	0x51C	Channel 1 task end-point
CH[2].EEP	0x520	Channel 2 event end-point
CH[2].TEP	0x524	Channel 2 task end-point
CH[3].EEP	0x528	Channel 3 event end-point
CH[3].TEP	0x52C	Channel 3 task end-point
CH[4].EEP	0x530	Channel 4 event end-point
CH[4].TEP	0x534	Channel 4 task end-point
CH[5].EEP	0x538	Channel 5 event end-point
CH[5].TEP	0x53C	Channel 5 task end-point
CH[6].EEP	0x540	Channel 6 event end-point
CH[6].TEP	0x544	Channel 6 task end-point

Register	Offset	Description
CH[7].EEP	0x548	Channel 7 event end-point
CH[7].TEP	0x54C	Channel 7 task end-point
CH[8].EEP	0x550	Channel 8 event end-point
CH[8].TEP	0x554	Channel 8 task end-point
CH[9].EEP	0x558	Channel 9 event end-point
CH[9].TEP	0x55C	Channel 9 task end-point
CH[10].EEP	0x560	Channel 10 event end-point
CH[10].TEP	0x564	Channel 10 task end-point
CH[11].EEP	0x568	Channel 11 event end-point
CH[11].TEP	0x56C	Channel 11 task end-point
CH[12].EEP	0x570	Channel 12 event end-point
CH[12].TEP	0x574	Channel 12 task end-point
CH[13].EEP	0x578	Channel 13 event end-point
CH[13].TEP	0x57C	Channel 13 task end-point
CH[14].EEP	0x580	Channel 14 event end-point
CH[14].TEP	0x584	Channel 14 task end-point
CH[15].EEP	0x588	Channel 15 event end-point
CH[15].TEP	0x58C	Channel 15 task end-point
CH[16].EEP	0x590	Channel 16 event end-point
CH[16].TEP	0x594	Channel 16 task end-point
CH[17].EEP	0x598	Channel 17 event end-point
CH[17].TEP	0x59C	Channel 17 task end-point
CH[18].EEP	0x5A0	Channel 18 event end-point
CH[18].TEP	0x5A4	Channel 18 task end-point
CH[19].EEP	0x5A8	Channel 19 event end-point
CH[19].TEP	0x5AC	Channel 19 task end-point
CHG[0]	0x800	Channel group 0
CHG[1]	0x804	Channel group 1
CHG[2]	0x808	Channel group 2
CHG[3]	0x80C	Channel group 3
CHG[4]	0x810	Channel group 4
CHG[5]	0x814	Channel group 5
FORK[0].TEP	0x910	Channel 0 task end-point
FORK[1].TEP	0x914	Channel 1 task end-point
FORK[2].TEP	0x918	Channel 2 task end-point
FORK[3].TEP	0x91C	Channel 3 task end-point
FORK[4].TEP	0x920	Channel 4 task end-point
FORK[5].TEP	0x924	Channel 5 task end-point
FORK[6].TEP	0x928	Channel 6 task end-point
FORK[7].TEP	0x92C	Channel 7 task end-point
FORK[8].TEP	0x930	Channel 8 task end-point
FORK[9].TEP	0x934	Channel 9 task end-point
FORK[10].TEP	0x938	Channel 10 task end-point
FORK[11].TEP	0x93C	Channel 11 task end-point
FORK[12].TEP	0x940	Channel 12 task end-point
FORK[13].TEP	0x944	Channel 13 task end-point
FORK[14].TEP	0x948	Channel 14 task end-point
FORK[15].TEP	0x94C	Channel 15 task end-point
FORK[16].TEP	0x950	Channel 16 task end-point
FORK[17].TEP	0x954	Channel 17 task end-point
FORK[18].TEP	0x958	Channel 18 task end-point
FORK[19].TEP	0x95C	Channel 19 task end-point
FORK[20].TEP	0x960	Channel 20 task end-point

Register	Offset	Description
FORK[21].TEP	0x964	Channel 21 task end-point
FORK[22].TEP	0x968	Channel 22 task end-point
FORK[23].TEP	0x96C	Channel 23 task end-point
FORK[24].TEP	0x970	Channel 24 task end-point
FORK[25].TEP	0x974	Channel 25 task end-point
FORK[26].TEP	0x978	Channel 26 task end-point
FORK[27].TEP	0x97C	Channel 27 task end-point
FORK[28].TEP	0x980	Channel 28 task end-point
FORK[29].TEP	0x984	Channel 29 task end-point
FORK[30].TEP	0x988	Channel 30 task end-point
FORK[31].TEP	0x98C	Channel 31 task end-point

Table 50: Register overview

6.11.2.1 TASKS_CHG[n].EN (n=0..5)

Address offset: $0x000 + (n \times 0x8)$

Enable channel group n

Bit number	31 30 29 28 27 26 25 24 23 22 21 20 19 18 17 16 15 14 13 12 11 10 9 8 7 6 5 4 3 2 1 0																														
ID	A																														
Reset 0x00000000	0 0																														
ID	Acce Field	Value ID	Value	Description																											
A	W EN	Trigger	1	Enable channel group n Trigger task																											

6.11.2.2 TASKS_CHG[n].DIS (n=0..5)

Address offset: $0x004 + (n \times 0x8)$

Disable channel group n

Bit number	31 30 29 28 27 26 25 24 23 22 21 20 19 18 17 16 15 14 13 12 11 10 9 8 7 6 5 4 3 2 1 0																														
ID	A																														
Reset 0x00000000	0 0																														
ID	Acce Field	Value ID	Value	Description																											
A	W DIS	Trigger	1	Disable channel group n Trigger task																											

6.11.2.3 CHEN

Address offset: 0x500

Channel enable register

Bit number	31 30 29 28 27 26 25 24 23 22 21 20 19 18 17 16 15 14 13 12 11 10 9 8 7 6 5 4 3 2 1 0																														
ID	f e d c b a Z Y X W V U T S R Q P O N M L K J I H G F E D C B A																														
Reset 0x00000000	0 0																														
ID	Acce Field	Value ID	Value	Description																											
A-f	RW CH[i] (i=0..31)	Disabled	0	Enable or disable channel i Disable channel																											
		Enabled	1	Enable channel																											

6.11.2.4 CHENSET

Address offset: 0x504

Channel enable set register

Read: reads value of CH{i} field in CHEN register.

Bit number	31 30 29 28 27 26 25 24 23 22 21 20 19 18 17 16 15 14 13 12 11 10 9 8 7 6 5 4 3 2 1 0																															
ID	f e d c b a Z Y X W V U T S R Q P O N M L K J I H G F E D C B A																															
Reset 0x00000000	0 0																															
ID	Acce	Field	Value ID	Value	Description																											
A-f	RW	CH[i] (i=0..31)			Channel i enable set register. Writing '0' has no effect																											
			Disabled	0	Read: channel disabled																											
			Enabled	1	Read: channel enabled																											
			Set	1	Write: Enable channel																											

6.11.2.5 CHENCLR

Address offset: 0x508

Channel enable clear register

Read: reads value of CH{i} field in CHEN register.

Bit number	31 30 29 28 27 26 25 24 23 22 21 20 19 18 17 16 15 14 13 12 11 10 9 8 7 6 5 4 3 2 1 0																															
ID	f e d c b a Z Y X W V U T S R Q P O N M L K J I H G F E D C B A																															
Reset 0x00000000	0 0																															
ID	Acce	Field	Value ID	Value	Description																											
A-f	RW	CH[i] (i=0..31)			Channel i enable clear register. Writing '0' has no effect																											
			Disabled	0	Read: channel disabled																											
			Enabled	1	Read: channel enabled																											
			Clear	1	Write: disable channel																											

6.11.2.6 CH[n].EEP (n=0..19)

Address offset: 0x510 + (n × 0x8)

Channel n event end-point

Bit number	31 30 29 28 27 26 25 24 23 22 21 20 19 18 17 16 15 14 13 12 11 10 9 8 7 6 5 4 3 2 1 0																															
ID	A A																															
Reset 0x00000000	0 0																															
ID	Acce	Field	Value ID	Value	Description																											
A	RW	EEP			Pointer to event register. Accepts only addresses to registers from the Event group.																											

6.11.2.7 CH[n].TEP (n=0..19)

Address offset: 0x514 + (n × 0x8)

Channel n task end-point

Bit number	31	30	29	28	27	26	25	24	23	22	21	20	19	18	17	16	15	14	13	12	11	10	9	8	7	6	5	4	3	2	1	0
ID	A	A	A	A	A	A	A	A	A	A	A	A	A	A	A	A	A	A	A	A	A	A	A	A	A	A	A	A	A	A	A	A
Reset 0x00000000	0	0	0	0	0	0	0	0	0	0	0	0	0	0	0	0	0	0	0	0	0	0	0	0	0	0	0	0	0	0	0	0
ID	Acce Field	Value ID	Value	Description																												
A	RW TEP			Pointer to task register. Accepts only addresses to registers from the Task group.																												

6.11.2.8 CHG[n] (n=0..5)

Address offset: $0x800 + (n \times 0x4)$

Channel group n

Bit number	31	30	29	28	27	26	25	24	23	22	21	20	19	18	17	16	15	14	13	12	11	10	9	8	7	6	5	4	3	2	1	0
ID	f	e	d	c	b	a	Z	Y	X	W	V	U	T	S	R	Q	P	O	N	M	L	K	J	I	H	G	F	E	D	C	B	A
Reset 0x00000000	0	0	0	0	0	0	0	0	0	0	0	0	0	0	0	0	0	0	0	0	0	0	0	0	0	0	0	0	0	0	0	
ID	Acce Field	Value ID	Value	Description																												
A-f	RW CH[i] (i=0..31)			Include or exclude channel i																												
		Excluded	0	Exclude																												
		Included	1	Include																												

6.11.2.9 FORK[n].TEP (n=0..31)

Address offset: $0x910 + (n \times 0x4)$

Channel n task end-point

Bit number	31	30	29	28	27	26	25	24	23	22	21	20	19	18	17	16	15	14	13	12	11	10	9	8	7	6	5	4	3	2	1	0
ID	A	A	A	A	A	A	A	A	A	A	A	A	A	A	A	A	A	A	A	A	A	A	A	A	A	A	A	A	A	A	A	
Reset 0x00000000	0	0	0	0	0	0	0	0	0	0	0	0	0	0	0	0	0	0	0	0	0	0	0	0	0	0	0	0	0	0	0	
ID	Acce Field	Value ID	Value	Description																												
A	RW TEP			Pointer to task register																												

6.12 PWM — Pulse width modulation

The pulse with modulation (PWM) module enables the generation of pulse width modulated signals on GPIO. The module implements an up or up-and-down counter with four PWM channels that drive assigned GPIOs.

The following are the main features of a PWM module:

- Programmable PWM frequency
- Up to four PWM channels with individual polarity and duty cycle values
- Edge or center-aligned pulses across PWM channels
- Multiple duty cycle arrays (sequences) defined in RAM
- Autonomous and glitch-free update of duty cycle values directly from memory through EasyDMA (no CPU involvement)
- Change of polarity, duty cycle, and base frequency possibly on every PWM period
- RAM sequences can be repeated or connected into loops

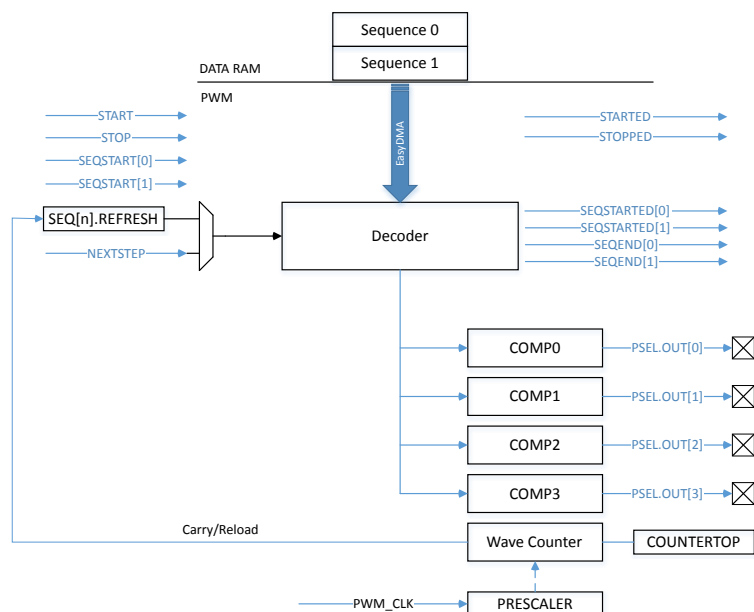

Figure 47: PWM module

6.12.1 Wave counter

The wave counter is responsible for generating the pulses at a duty cycle that depends on the compare values, and at a frequency that depends on COUNTERTOP.

There is one common 15-bit counter with four compare channels. Thus, all four channels will share the same period (PWM frequency), but can have individual duty cycle and polarity. The polarity is set by a value read from RAM (see figure [Decoder memory access modes](#) on page 150). Whether the counter counts up, or up and down, is controlled by the MODE register.

The timer top value is controlled by the COUNTERTOP register. This register value, in conjunction with the selected PRESCALER of the PWM_CLK, will result in a given PWM period. A COUNTERTOP value smaller than the compare setting will result in a state where no PWM edges are generated. OUT[n] is held high, given that the polarity is set to FallingEdge. All compare registers are internal and can only be configured through decoder presented later. COUNTERTOP can be safely written at any time.

Sampling follows the START task. If DECODER.LOAD=WaveForm, the register value is ignored and taken from RAM instead (see section [Decoder with EasyDMA](#) on page 150 for more details). If DECODER.LOAD is anything else than the WaveForm, it is sampled following a STARTSEQ[n] task and when loading a new value from RAM during a sequence playback.

The following figure shows the counter operating in up mode (MODE=PWM_MODE_Up), with three PWM channels with the same frequency but different duty cycle:

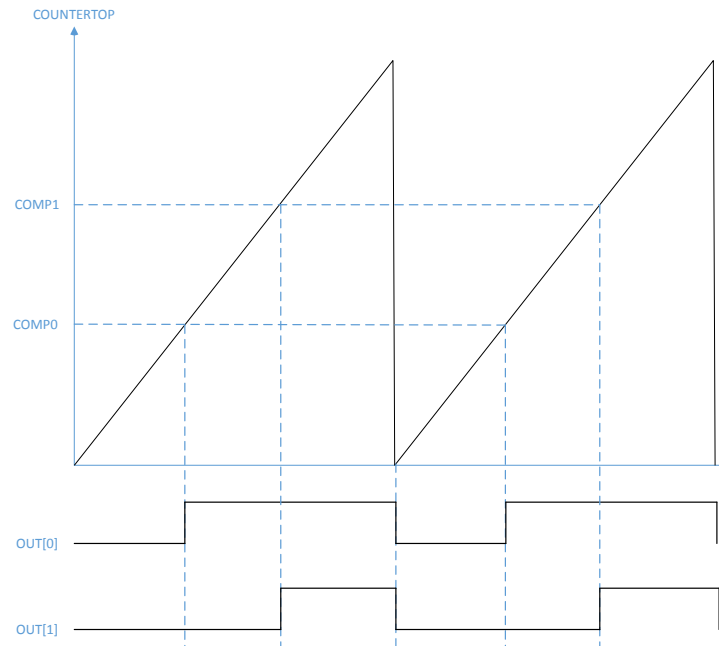

Figure 48: PWM counter in up mode example - FallingEdge polarity

The counter is automatically reset to zero when COUNTERTOP is reached and OUT[n] will invert. OUT[n] is held low if the compare value is 0 and held high if set to COUNTERTOP, given that the polarity is set to FallingEdge. Counter running in up mode results in pulse widths that are edge-aligned. The following is the code for the counter in up mode example:

```
uint16_t pwm_seq[4] = {PWM_CH0_DUTY, PWM_CH1_DUTY, PWM_CH2_DUTY, PWM_CH3_DUTY};
NRF_PWM0->PSEL.OUT[0] = (first_pin << PWM_PSEL_OUT_PIN_Pos) |
    (PWM_PSEL_OUT_CONNECT_Connected <<
        PWM_PSEL_OUT_CONNECT_Pos);
NRF_PWM0->PSEL.OUT[1] = (second_pin << PWM_PSEL_OUT_PIN_Pos) |
    (PWM_PSEL_OUT_CONNECT_Connected <<
        PWM_PSEL_OUT_CONNECT_Pos);
NRF_PWM0->ENABLE = (PWM_ENABLE_ENABLE_Enabled << PWM_ENABLE_ENABLE_Pos);
NRF_PWM0->MODE = (PWM_MODE_UPDOWN_Up << PWM_MODE_UPDOWN_Pos);
NRF_PWM0->PRESCALER = (PWM_PRESCALER_PRESCALER_DIV_1 <<
    PWM_PRESCALER_PRESCALER_Pos);
NRF_PWM0->COUNTERTOP = (16000 << PWM_COUNTERTOP_COUNTERTOP_Pos); //1 msec
NRF_PWM0->LOOP = (PWM_LOOP_CNT_Disabled << PWM_LOOP_CNT_Pos);
NRF_PWM0->DECODER = (PWM_DECODER_LOAD_Individual << PWM_DECODER_LOAD_Pos) |
    (PWM_DECODER_MODE_RefreshCount << PWM_DECODER_MODE_Pos);
NRF_PWM0->SEQ[0].PTR = ((uint32_t) (pwm_seq) << PWM_SEQ_PTR_PTR_Pos);
NRF_PWM0->SEQ[0].CNT = ((sizeof(pwm_seq) / sizeof(uint16_t)) <<
    PWM_SEQ_CNT_CNT_Pos);

NRF_PWM0->SEQ[0].REFRESH = 0;
NRF_PWM0->SEQ[0].ENDDelay = 0;
NRF_PWM0->TASKS_SEQSTART[0] = 1;
```

When the counter is running in up mode, the following formula can be used to compute the PWM period and the step size:

$$\text{PWM period: } T_{\text{PWM(Up)}} = T_{\text{PWM_CLK}} * \text{COUNTERTOP}$$

Step width/Resolution: $T_{steps} = T_{PWM_CLK}$

The following figure shows the counter operating in up-and-down mode (MODE=PWM_MODE_UpAndDown), with two PWM channels with the same frequency but different duty cycle and output polarity:

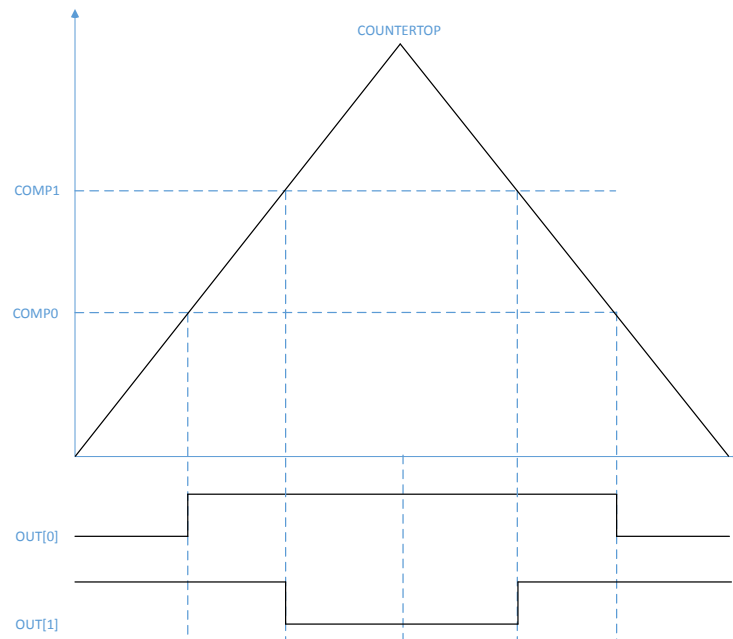

Figure 49: PWM counter in up-and-down mode example

The counter starts decrementing to zero when COUNTERTOP is reached and will invert the OUT[n] when compare value is hit for the second time. This results in a set of pulses that are center-aligned. The following is the code for the counter in up-and-down mode example:

```
uint16_t pwm_seq[4] = {PWM_CH0_DUTY, PWM_CH1_DUTY, PWM_CH2_DUTY, PWM_CH3_DUTY};
NRF_PWM0->PSEL.OUT[0] = (first_pin << PWM_PSEL_OUT_PIN_Pos) |
    (PWM_PSEL_OUT_CONNECT_Connected <<
        PWM_PSEL_OUT_CONNECT_Pos);
NRF_PWM0->PSEL.OUT[1] = (second_pin << PWM_PSEL_OUT_PIN_Pos) |
    (PWM_PSEL_OUT_CONNECT_Connected <<
        PWM_PSEL_OUT_CONNECT_Pos);
NRF_PWM0->ENABLE = (PWM_ENABLE_ENABLE_Enabled << PWM_ENABLE_ENABLE_Pos);
NRF_PWM0->MODE = (PWM_MODE_UPDOWN_UpAndDown << PWM_MODE_UPDOWN_Pos);
NRF_PWM0->PRESCALER = (PWM_PRESCALER_PRESCALER_DIV_1 <<
    PWM_PRESCALER_PRESCALER_Pos);
NRF_PWM0->COUNTERTOP = (16000 << PWM_COUNTERTOP_COUNTERTOP_Pos); //1 msec
NRF_PWM0->LOOP = (PWM_LOOP_CNT_Disabled << PWM_LOOP_CNT_Pos);
NRF_PWM0->DECODER = (PWM_DECODER_LOAD_Individual << PWM_DECODER_LOAD_Pos) |
    (PWM_DECODER_MODE_RefreshCount << PWM_DECODER_MODE_Pos);
NRF_PWM0->SEQ[0].PTR = ((uint32_t)(pwm_seq) << PWM_SEQ_PTR_PTR_Pos);
NRF_PWM0->SEQ[0].CNT = ((sizeof(pwm_seq) / sizeof(uint16_t)) <<
    PWM_SEQ_CNT_CNT_Pos);
NRF_PWM0->SEQ[0].REFRESH = 0;
NRF_PWM0->SEQ[0].ENDDelay = 0;
NRF_PWM0->TASKS_SEQSTART[0] = 1;
```

When the counter is running in up-and-down mode, the following formula can be used to compute the PWM period and the step size:

$$T_{PWM(Up\ And\ Down)} = T_{PWM_CLK} * 2 * COUNTERTOP$$

Step width/Resolution: $T_{steps} = T_{PWM_CLK} * 2$

6.12.2 Decoder with EasyDMA

The decoder uses EasyDMA to take PWM parameters stored in RAM and update the internal compare registers of the wave counter, based on the mode of operation.

PWM parameters are organized into a sequence containing at least one half word (16 bit). Its most significant bit[15] denotes the polarity of the OUT[n] while bit[14:0] is the 15-bit compare value.

Bit number	31 30 29 28 27 26 25 24 23 22 21 20 19 18 17 16 15 14 13 12 11 10 9 8 7 6 5 4 3 2 1 0																																																							
Id																															B	A	A	A	A	A	A	A	A	A	A	A	A	A	A	A	A	A	A	A	A	A	A	A	A	A
Reset 0x00000000	0 0																																																							
Id	RW	Field	Value Id	Value	Description																																																			
A	RW	COMPARE			Duty cycle setting - value loaded to internal compare register																																																			
B	RW	POLARITY			Edge polarity of GPIO.																																																			
			RisingEdge	0	First edge within the PWM period is rising																																																			
			FallingEdge	1	First edge within the PWM period is falling																																																			

The DECODER register controls how the RAM content is interpreted and loaded into the internal compare registers. The LOAD field controls if the RAM values are loaded to all compare channels, or to update a group or all channels with individual values. The following figure illustrates how parameters stored in RAM are organized and routed to various compare channels in different modes:

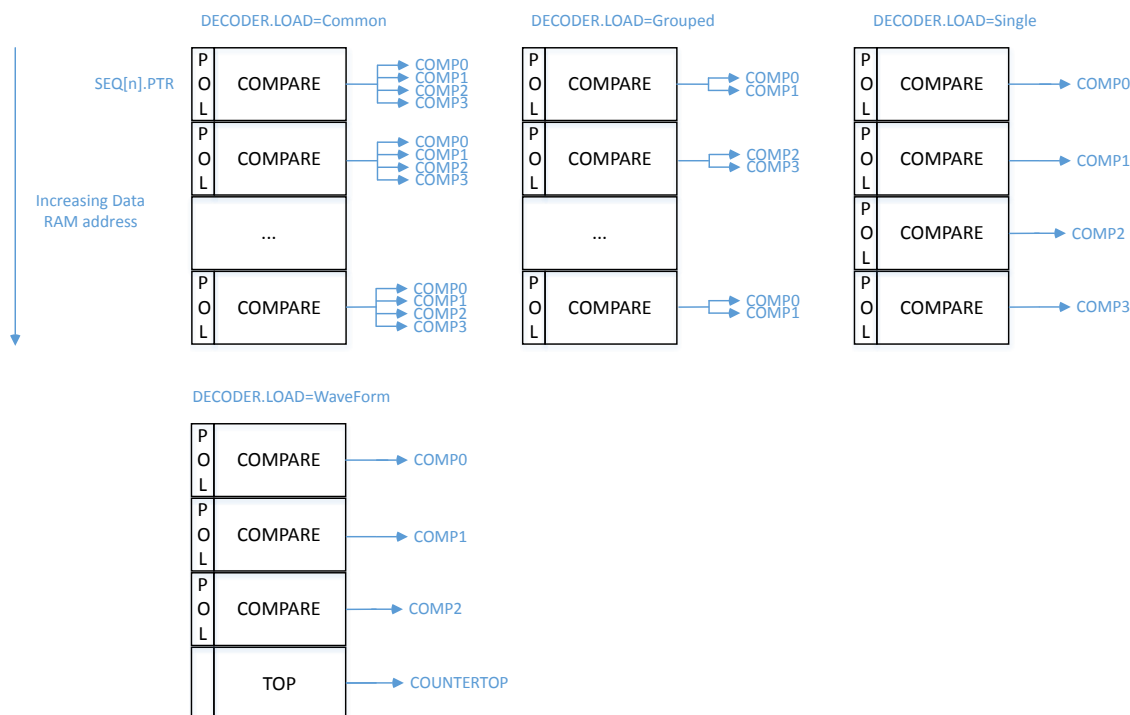

Figure 50: Decoder memory access modes

A special mode of operation is available when DECODER.LOAD is set to WaveForm. In this mode, up to three PWM channels can be enabled - OUT[0] to OUT[2]. In RAM, four values are loaded at a time: the first, second and third location are used to load the values, and the fourth RAM location is used to load

the COUNTERTOP register. This way one can have up to three PWM channels with a frequency base that changes on a per PWM period basis. This mode of operation is useful for arbitrary wave form generation in applications, such as LED lighting.

The register SEQ[n].REFRESH=N (one per sequence n=0 or 1) will instruct a new RAM stored pulse width value on every (N+1)th PWM period. Setting the register to zero will result in a new duty cycle update every PWM period, as long as the minimum PWM period is observed.

Note that registers SEQ[n].REFRESH and SEQ[n].ENDDelay are ignored when DECODER.MODE=NextStep. The next value is loaded upon every received NEXTSTEP task.

SEQ[n].PTR is the pointer used to fetch COMPARE values from RAM. If the SEQ[n].PTR is not pointing to a RAM region, an EasyDMA transfer may result in a HardFault or RAM corruption. See [Memory](#) on page 17 for more information about the different memory regions. After the SEQ[n].PTR is set to the desired RAM location, the SEQ[n].CNT register must be set to number of 16-bit half words in the sequence. It is important to observe that the Grouped mode requires one half word per group, while the Single mode requires one half word per channel, thus increasing the RAM size occupation. If PWM generation is not running when the SEQSTART[n] task is triggered, the task will load the first value from RAM and then start the PWM generation. A SEQSTARTED[n] event is generated as soon as the EasyDMA has read the first PWM parameter from RAM and the wave counter has started executing it. When LOOP.CNT=0, sequence n=0 or 1 is played back once. After the last value in the sequence has been loaded and started executing, a SEQEND[n] event is generated. The PWM generation will then continue with the last loaded value. The following figure illustrates an example of such simple playback:

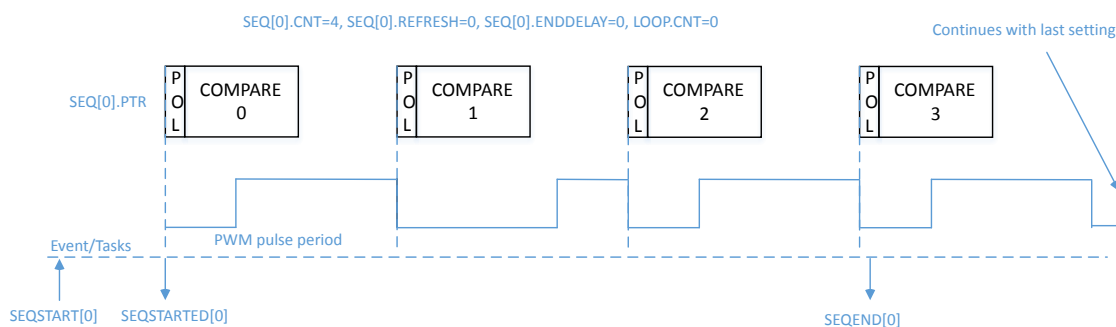

Figure 51: Simple sequence example

Figure depicts the source code used for configuration and timing details in a sequence where only sequence 0 is used and only run once with a new PWM duty cycle for each period.

```

NRF_PWM0->PSEL.OUT[0] = (first_pin << PWM_PSEL_OUT_PIN_Pos) |
                        (PWM_PSEL_OUT_CONNECT_Connected <<
                         PWM_PSEL_OUT_CONNECT_Pos);
NRF_PWM0->ENABLE      = (PWM_ENABLE_ENABLE_Enabled << PWM_ENABLE_ENABLE_Pos);
NRF_PWM0->MODE        = (PWM_MODE_UPDOWN_Up << PWM_MODE_UPDOWN_Pos);
NRF_PWM0->PRESCALER   = (PWM_PRESCALER_PRESCALER_DIV_1 <<
                         PWM_PRESCALER_PRESCALER_Pos);
NRF_PWM0->COUNTERTOP  = (16000 << PWM_COUNTERTOP_COUNTERTOP_Pos); //1 msec
NRF_PWM0->LOOP        = (PWM_LOOP_CNT_Disabled << PWM_LOOP_CNT_Pos);
NRF_PWM0->DECODER     = (PWM_DECODER_LOAD_Common << PWM_DECODER_LOAD_Pos) |
                        (PWM_DECODER_MODE_RefreshCount << PWM_DECODER_MODE_Pos);
NRF_PWM0->SEQ[0].PTR  = ((uint32_t)(seq0_ram) << PWM_SEQ_PTR_PTR_Pos);
NRF_PWM0->SEQ[0].CNT  = ((sizeof(seq0_ram) / sizeof(uint16_t)) <<
                         PWM_SEQ_CNT_CNT_Pos);

NRF_PWM0->SEQ[0].REFRESH = 0;
NRF_PWM0->SEQ[0].ENDDelay = 0;
NRF_PWM0->TASKS_SEQSTART[0] = 1;

```

To completely stop the PWM generation and force the associated pins to a defined state, a STOP task can be triggered at any time. A STOPPED event is generated when the PWM generation has stopped at the end of currently running PWM period, and the pins go into their idle state as defined in GPIO OUT register. PWM generation can then only be restarted through a SEQSTART[n] task. SEQSTART[n] will resume PWM generation after having loaded the first value from the RAM buffer defined in the SEQ[n].PTR register.

The table below indicates when specific registers get sampled by the hardware. Care should be taken when updating these registers to avoid that values are applied earlier than expected.

Register	Taken into account by hardware	Recommended (safe) update
SEQ[n].PTR	When sending the SEQSTART[n] task	After having received the SEQSTARTED[n] event
SEQ[n].CNT	When sending the SEQSTART[n] task	After having received the SEQSTARTED[n] event
SEQ[0].ENDDelay	When sending the SEQSTART[0] task Every time a new value from sequence [0] has been loaded from RAM and gets applied to the Wave Counter (indicated by the PWMPERIODEND event)	Before starting sequence [0] through a SEQSTART[0] task When no more value from sequence [0] gets loaded from RAM (indicated by the SEQEND[0] event) At any time during sequence [1] (which starts when the SEQSTARTED[1] event is generated)
SEQ[1].ENDDelay	When sending the SEQSTART[1] task Every time a new value from sequence [1] has been loaded from RAM and gets applied to the Wave Counter (indicated by the PWMPERIODEND event)	Before starting sequence [1] through a SEQSTART[1] task When no more value from sequence [1] gets loaded from RAM (indicated by the SEQEND[1] event) At any time during sequence [0] (which starts when the SEQSTARTED[0] event is generated)
SEQ[0].REFRESH	When sending the SEQSTART[0] task Every time a new value from sequence [0] has been loaded from RAM and gets applied to the Wave Counter (indicated by the PWMPERIODEND event)	Before starting sequence [0] through a SEQSTART[0] task At any time during sequence [1] (which starts when the SEQSTARTED[1] event is generated)
SEQ[1].REFRESH	When sending the SEQSTART[1] task Every time a new value from sequence [1] has been loaded from RAM and gets applied to the Wave Counter (indicated by the PWMPERIODEND event)	Before starting sequence [1] through a SEQSTART[1] task At any time during sequence [0] (which starts when the SEQSTARTED[0] event is generated)
COUNTERTOP	In DECODER.LOAD=WaveForm: this register is ignored. In all other LOAD modes: at the end of current PWM period (indicated by the PWMPERIODEND event)	Before starting PWM generation through a SEQSTART[n] task After a STOP task has been triggered, and the STOPPED event has been received.
MODE	Immediately	Before starting PWM generation through a SEQSTART[n] task After a STOP task has been triggered, and the STOPPED event has been received.
DECODER	Immediately	Before starting PWM generation through a SEQSTART[n] task After a STOP task has been triggered, and the STOPPED event has been received.
PRESCALER	Immediately	Before starting PWM generation through a SEQSTART[n] task After a STOP task has been triggered, and the STOPPED event has been received.
LOOP	Immediately	Before starting PWM generation through a SEQSTART[n] task After a STOP task has been triggered, and the STOPPED event has been received.
PSEL.OUT[n]	Immediately	Before enabling the PWM instance through the ENABLE register

Table 51: When to safely update PWM registers

Note: SEQ[n].REFRESH and SEQ[n].ENDDelay are ignored at the end of a complex sequence, indicated by a LOOPSDONE event. The reason for this is that the last value loaded from RAM is maintained until further action from software (restarting a new sequence, or stopping PWM generation).

A more complex example, where LOOP.CNT>0, is shown in the following figure:

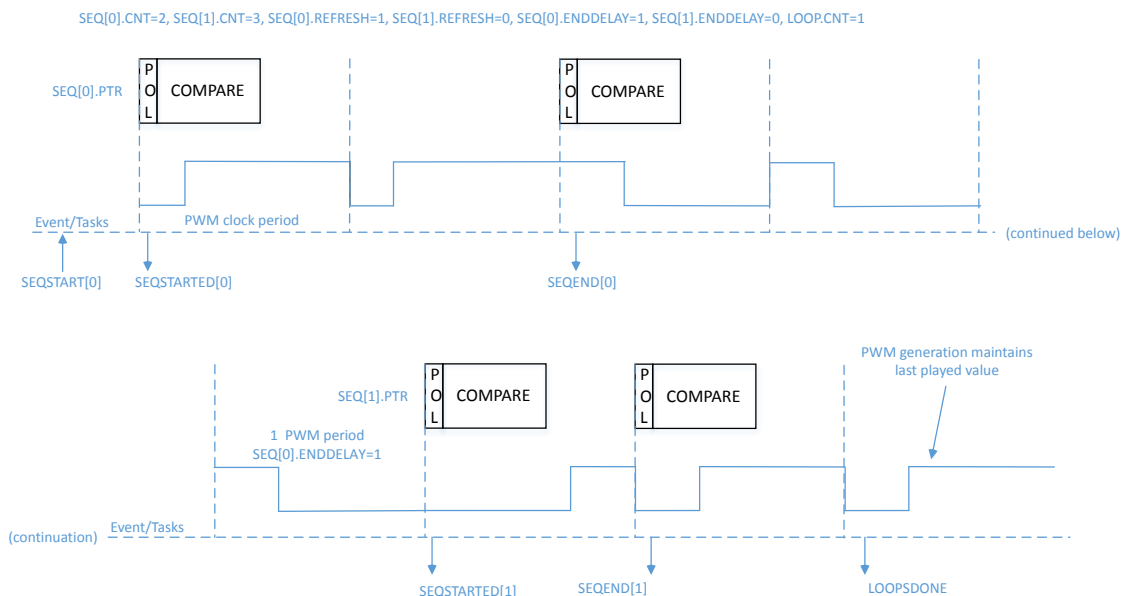

Figure 52: Example using two sequences

In this case, an automated playback takes place, consisting of SEQ[0], delay 0, SEQ[1], delay 1, then again SEQ[0], etc. The user can choose to start a complex playback with SEQ[0] or SEQ[1] through sending the SEQSTART[0] or SEQSTART[1] task. The complex playback always ends with delay 1.

The two sequences 0 and 1 are defined by the addresses of value tables in RAM (pointed to by SEQ[n].PTR) and the buffer size (SEQ[n].CNT). The rate at which a new value is loaded is defined individually for each sequence by SEQ[n].REFRESH. The chaining of sequence 1 following the sequence 0 is implicit, the LOOP.CNT register allows the chaining of sequence 1 to sequence 0 for a determined number of times. In other words, it allows to repeat a complex sequence a number of times in a fully automated way.

In the following code example, sequence 0 is defined with SEQ[0].REFRESH set to 1, meaning that a new PWM duty cycle is pushed every second PWM period. This complex sequence is started with the SEQSTART[0] task, so SEQ[0] is played first. Since SEQ[0].ENDDDELAY=1 there will be one PWM period delay between last period on sequence 0 and the first period on sequence 1. Since SEQ[1].ENDDDELAY=0 there is no delay 1, so SEQ[0] would be started immediately after the end of SEQ[1]. However, as LOOP.CNT is

1, the playback stops after having played SEQ[1] only once, and both SEQEND[1] and LOOPSDONE are generated (their order is not guaranteed in this case).

```

NRF_PWM0->PSEL.OUT[0] = (first_pin << PWM_PSEL_OUT_PIN_Pos) |
                        (PWM_PSEL_OUT_CONNECT_Connected <<
                         PWM_PSEL_OUT_CONNECT_Pos);
NRF_PWM0->ENABLE      = (PWM_ENABLE_ENABLE_Enabled << PWM_ENABLE_ENABLE_Pos);
NRF_PWM0->MODE        = (PWM_MODE_UPDOWN_Up << PWM_MODE_UPDOWN_Pos);
NRF_PWM0->PRESCALER   = (PWM_PRESCALER_PRESCALER_DIV_1 <<
                         PWM_PRESCALER_PRESCALER_Pos);
NRF_PWM0->COUNTERTOP  = (16000 << PWM_COUNTERTOP_COUNTERTOP_Pos); //1 msec
NRF_PWM0->LOOP        = (1 << PWM_LOOP_CNT_Pos);
NRF_PWM0->DECODER     = (PWM_DECODER_LOAD_Common << PWM_DECODER_LOAD_Pos) |
                        (PWM_DECODER_MODE_RefreshCount << PWM_DECODER_MODE_Pos);
NRF_PWM0->SEQ[0].PTR  = ((uint32_t)(seq0_ram) << PWM_SEQ_PTR_PTR_Pos);
NRF_PWM0->SEQ[0].CNT  = ((sizeof(seq0_ram) / sizeof(uint16_t)) <<
                         PWM_SEQ_CNT_CNT_Pos);

NRF_PWM0->SEQ[0].REFRESH = 1;
NRF_PWM0->SEQ[0].ENDDELAY = 1;
NRF_PWM0->SEQ[1].PTR  = ((uint32_t)(seq1_ram) << PWM_SEQ_PTR_PTR_Pos);
NRF_PWM0->SEQ[1].CNT  = ((sizeof(seq1_ram) / sizeof(uint16_t)) <<
                         PWM_SEQ_CNT_CNT_Pos);

NRF_PWM0->SEQ[1].REFRESH = 0;
NRF_PWM0->SEQ[1].ENDDELAY = 0;
NRF_PWM0->TASKS_SEQSTART[0] = 1;

```

The decoder can also be configured to asynchronously load new PWM duty cycle. If the DECODER.MODE register is set to NextStep, then the NEXTSTEP task will cause an update of internal compare registers on the next PWM period.

The following figures provide an overview of each part of an arbitrary sequence, in various modes (LOOP.CNT=0 and LOOP.CNT>0). In particular, the following are represented:

- Initial and final duty cycle on the PWM output(s)
- Chaining of SEQ[0] and SEQ[1] if LOOP.CNT>0
- Influence of registers on the sequence
- Events generated during a sequence
- DMA activity (loading of next value and applying it to the output(s))

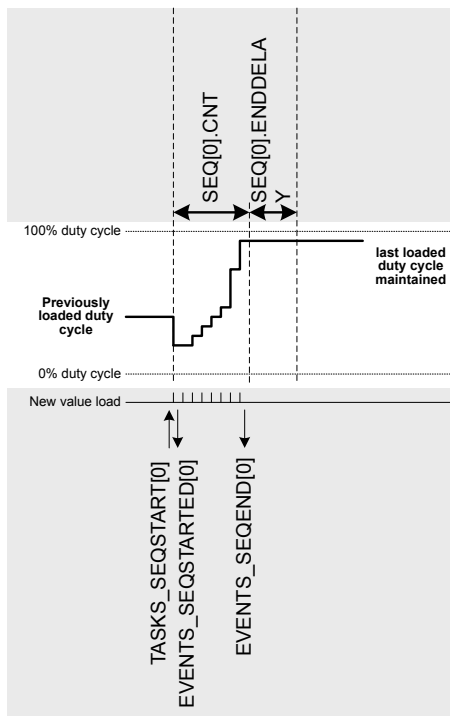

Figure 53: Single shot (LOOP.CNT=0)

Note: The single-shot example also applies to SEQ[1]. Only SEQ[0] is represented for simplicity.

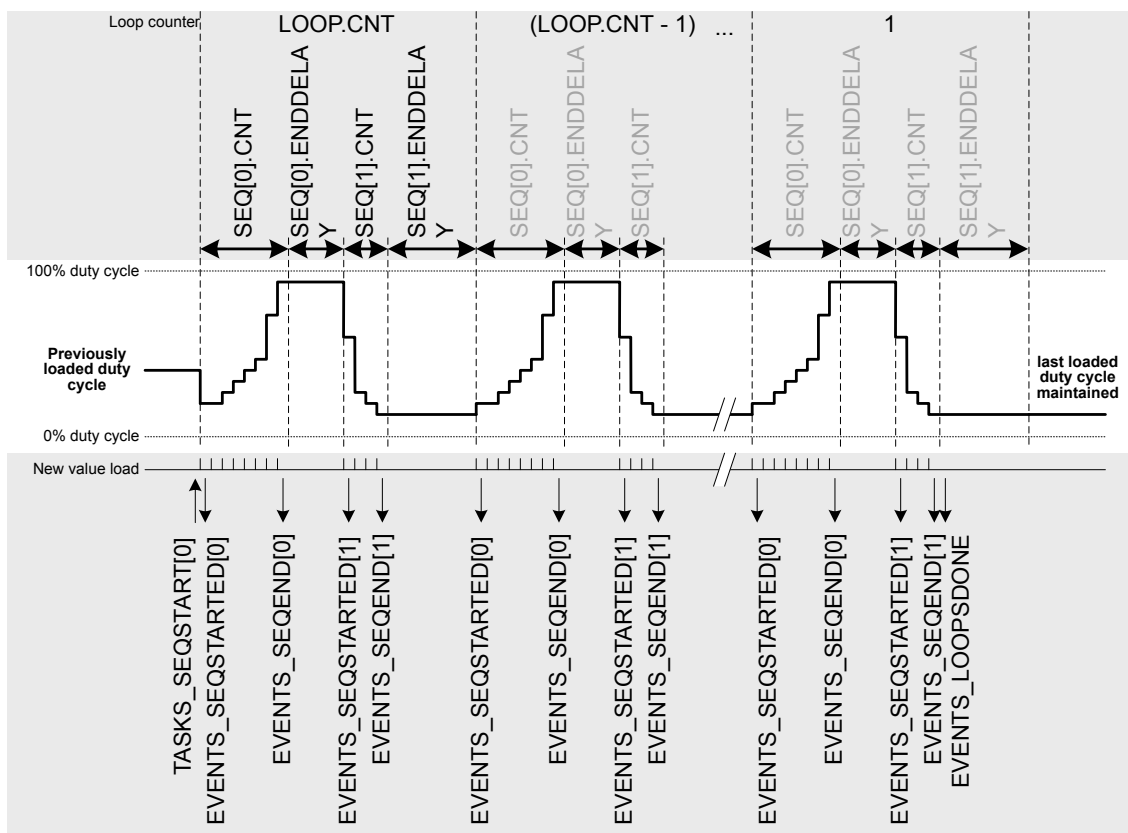

Figure 54: Complex sequence (LOOP.CNT>0) starting with SEQ[0]

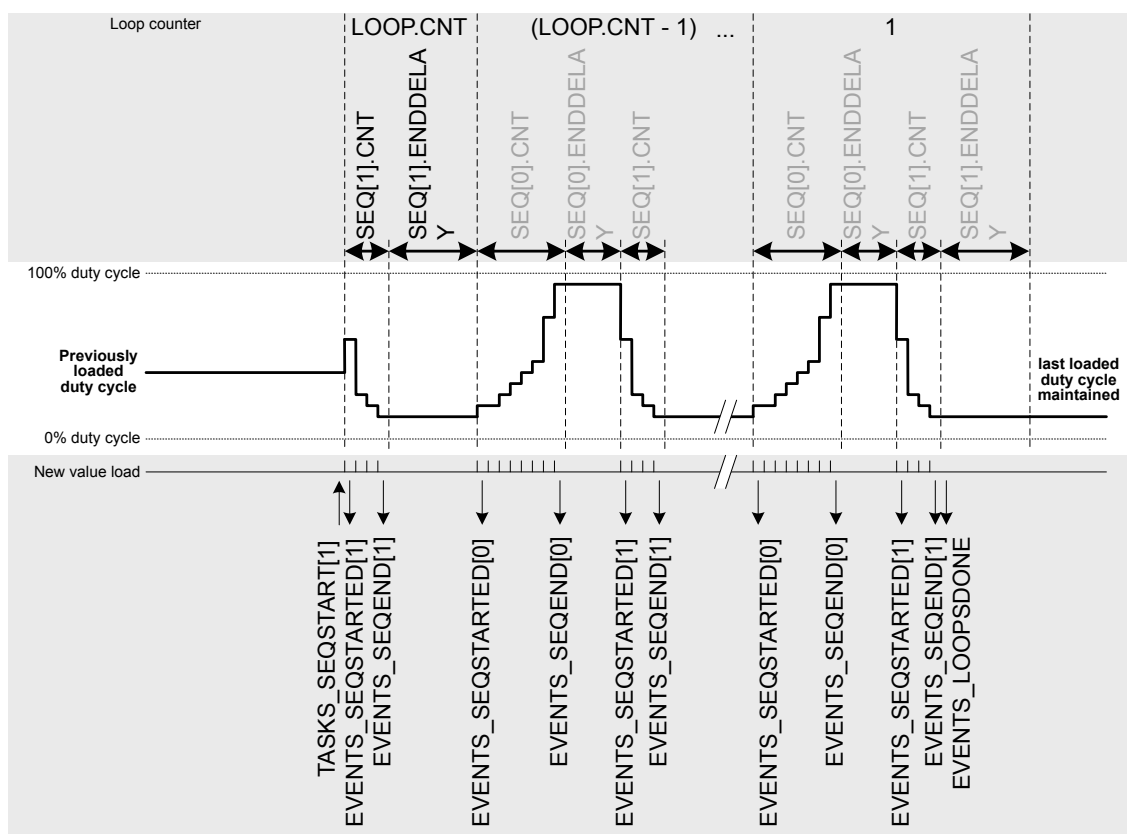

Figure 55: Complex sequence ($LOOP.CNT > 0$) starting with $SEQ[1]$

Note: If a sequence is in use in a simple or complex sequence, it must have a length of $SEQ[n].CNT > 0$.

6.12.3 Limitations

Previous compare value is repeated if the PWM period is shorter than the time it takes for the EasyDMA to retrieve from RAM and update the internal compare registers. This is to ensure a glitch-free operation even for very short PWM periods.

6.12.4 Pin configuration

The $OUT[n]$ ($n=0..3$) signals associated with each PWM channel are mapped to physical pins according to the configuration of $PSEL.OUT[n]$ registers. If $PSEL.OUT[n].CONNECT$ is set to Disconnected, the associated PWM module signal will not be connected to any physical pins.

The $PSEL.OUT[n]$ registers and their configurations are used as long as the PWM module is enabled and the PWM generation active (wave counter started). They are retained only as long as the device is in System ON mode (see section [POWER](#) for more information about power modes).

To ensure correct behavior in the PWM module, the pins that are used must be configured in the GPIO peripheral in the following way before the PWM module is enabled:

PWM signal	PWM pin	Direction	Output value	Comment
$OUT[n]$	As specified in $PSEL.OUT[n]$ ($n=0..3$)	Output	0	Idle state defined in GPIO OUT register

Table 52: Recommended GPIO configuration before starting PWM generation

The idle state of a pin is defined by the OUT register in the GPIO module, to ensure that the pins used by the PWM module are driven correctly. If PWM generation is stopped by triggering a STOP task, the PWM module itself is temporarily disabled or the device temporarily enters System OFF. This configuration must be retained in the GPIO for the selected pins (I/Os) for as long as the PWM module is supposed to be connected to an external PWM circuit.

Only one peripheral can be assigned to drive a particular GPIO pin at a time. Failing to do so may result in unpredictable behavior.

6.12.5 Registers

Base address	Peripheral	Instance	Description	Configuration
0x4001C000	PWM	PWM0	Pulse-width modulation unit 0	

Table 53: Instances

Register	Offset	Description
TASKS_STOP	0x004	Stops PWM pulse generation on all channels at the end of current PWM period, and stops sequence playback
TASKS_SEQSTART[0]	0x008	Loads the first PWM value on all enabled channels from sequence 0, and starts playing that sequence at the rate defined in SEQ[0]REFRESH and/or DECODER.MODE. Causes PWM generation to start if not running.
TASKS_SEQSTART[1]	0x00C	Loads the first PWM value on all enabled channels from sequence 1, and starts playing that sequence at the rate defined in SEQ[1]REFRESH and/or DECODER.MODE. Causes PWM generation to start if not running.
TASKS_NEXTSTEP	0x010	Steps by one value in the current sequence on all enabled channels if DECODER.MODE=NextStep. Does not cause PWM generation to start if not running.
EVENTS_STOPPED	0x104	Response to STOP task, emitted when PWM pulses are no longer generated
EVENTS_SEQSTARTED[0]	0x108	First PWM period started on sequence 0
EVENTS_SEQSTARTED[1]	0x10C	First PWM period started on sequence 1
EVENTS_SEQEND[0]	0x110	Emitted at end of every sequence 0, when last value from RAM has been applied to wave counter
EVENTS_SEQEND[1]	0x114	Emitted at end of every sequence 1, when last value from RAM has been applied to wave counter
EVENTS_PWMPERIODEND	0x118	Emitted at the end of each PWM period
EVENTS_LOOPSDONE	0x11C	Concatenated sequences have been played the amount of times defined in LOOP.CNT
SHORTS	0x200	Shortcuts between local events and tasks
INTEN	0x300	Enable or disable interrupt
INTENSET	0x304	Enable interrupt
INTENCLR	0x308	Disable interrupt
ENABLE	0x500	PWM module enable register
MODE	0x504	Selects operating mode of the wave counter
COUNTERTOP	0x508	Value up to which the pulse generator counter counts
PRESCALER	0x50C	Configuration for PWM_CLK
DECODER	0x510	Configuration of the decoder
LOOP	0x514	Number of playbacks of a loop
SEQ[0].PTR	0x520	Beginning address in RAM of this sequence
SEQ[0].CNT	0x524	Number of values (duty cycles) in this sequence
SEQ[0].REFRESH	0x528	Number of additional PWM periods between samples loaded into compare register
SEQ[0].ENDELAY	0x52C	Time added after the sequence
SEQ[1].PTR	0x540	Beginning address in RAM of this sequence
SEQ[1].CNT	0x544	Number of values (duty cycles) in this sequence
SEQ[1].REFRESH	0x548	Number of additional PWM periods between samples loaded into compare register
SEQ[1].ENDELAY	0x54C	Time added after the sequence

Register	Offset	Description
PSEL.OUT[0]	0x560	Output pin select for PWM channel 0
PSEL.OUT[1]	0x564	Output pin select for PWM channel 1
PSEL.OUT[2]	0x568	Output pin select for PWM channel 2
PSEL.OUT[3]	0x56C	Output pin select for PWM channel 3

Table 54: Register overview

6.12.5.1 TASKS_STOP

Address offset: 0x004

Stops PWM pulse generation on all channels at the end of current PWM period, and stops sequence playback

Bit number	31 30 29 28 27 26 25 24 23 22 21 20 19 18 17 16 15 14 13 12 11 10 9 8 7 6 5 4 3 2 1 0																															
ID																																A
Reset	0x00000000																															0 0
ID	Acce Field	Value ID	Value	Description																												
A	W	TASKS_STOP		Stops PWM pulse generation on all channels at the end of current PWM period, and stops sequence playback																												
		Trigger	1	Trigger task																												

6.12.5.2 TASKS_SEQSTART[n] (n=0..1)

Address offset: 0x008 + (n × 0x4)

Loads the first PWM value on all enabled channels from sequence n, and starts playing that sequence at the rate defined in SEQ[n]REFRESH and/or DECODER.MODE. Causes PWM generation to start if not running.

Bit number	31 30 29 28 27 26 25 24 23 22 21 20 19 18 17 16 15 14 13 12 11 10 9 8 7 6 5 4 3 2 1 0																															
ID																																A
Reset	0x00000000																															0 0
ID	Acce Field	Value ID	Value	Description																												
A	W	TASKS_SEQSTART		Loads the first PWM value on all enabled channels from sequence n, and starts playing that sequence at the rate defined in SEQ[n]REFRESH and/or DECODER.MODE. Causes PWM generation to start if not running.																												
		Trigger	1	Trigger task																												

6.12.5.3 TASKS_NEXTSTEP

Address offset: 0x010

Steps by one value in the current sequence on all enabled channels if DECODER.MODE=NextStep. Does not cause PWM generation to start if not running.

Bit number	31	30	29	28	27	26	25	24	23	22	21	20	19	18	17	16	15	14	13	12	11	10	9	8	7	6	5	4	3	2	1	0
ID																																A
Reset	0x00000000																															
0	0	0	0	0	0	0	0	0	0	0	0	0	0	0	0	0	0	0	0	0	0	0	0	0	0	0	0	0	0	0	0	0
ID	Acce Field	Value ID	Value	Description																												
A	W	TASKS_NEXTSTEP		Steps by one value in the current sequence on all enabled channels if DECODER.MODE=NextStep. Does not cause PWM generation to start if not running.																												
		Trigger	1	Trigger task																												

6.12.5.4 EVENTS_STOPPED

Address offset: 0x104

Response to STOP task, emitted when PWM pulses are no longer generated

Bit number	31	30	29	28	27	26	25	24	23	22	21	20	19	18	17	16	15	14	13	12	11	10	9	8	7	6	5	4	3	2	1	0
ID																																A
Reset	0x00000000																															
0	0	0	0	0	0	0	0	0	0	0	0	0	0	0	0	0	0	0	0	0	0	0	0	0	0	0	0	0	0	0	0	
ID	Acce Field	Value ID	Value	Description																												
A	RW	EVENTS_STOPPED		Response to STOP task, emitted when PWM pulses are no longer generated																												
		NotGenerated	0	Event not generated																												
		Generated	1	Event generated																												

6.12.5.5 EVENTS_SEQSTARTED[n] (n=0..1)

Address offset: 0x108 + (n × 0x4)

First PWM period started on sequence n

Bit number	31	30	29	28	27	26	25	24	23	22	21	20	19	18	17	16	15	14	13	12	11	10	9	8	7	6	5	4	3	2	1	0
ID																																A
Reset	0x00000000																															
0	0	0	0	0	0	0	0	0	0	0	0	0	0	0	0	0	0	0	0	0	0	0	0	0	0	0	0	0	0	0	0	
ID	Acce Field	Value ID	Value	Description																												
A	RW	EVENTS_SEQSTARTED		First PWM period started on sequence n																												
		NotGenerated	0	Event not generated																												
		Generated	1	Event generated																												

6.12.5.6 EVENTS_SEQEND[n] (n=0..1)

Address offset: 0x110 + (n × 0x4)

Emitted at end of every sequence n, when last value from RAM has been applied to wave counter

Bit number	31	30	29	28	27	26	25	24	23	22	21	20	19	18	17	16	15	14	13	12	11	10	9	8	7	6	5	4	3	2	1	0
ID																																A
Reset	0x00000000																															
0	0	0	0	0	0	0	0	0	0	0	0	0	0	0	0	0	0	0	0	0	0	0	0	0	0	0	0	0	0	0	0	
ID	Acce Field	Value ID	Value	Description																												
A	RW	EVENTS_SEQEND		Emitted at end of every sequence n, when last value from RAM has been applied to wave counter																												
		NotGenerated	0	Event not generated																												
		Generated	1	Event generated																												

6.12.5.7 EVENTS_PWMPERIODEND

Address offset: 0x118

Emitted at the end of each PWM period

Bit number	31 30 29 28 27 26 25 24 23 22 21 20 19 18 17 16 15 14 13 12 11 10 9 8 7 6 5 4 3 2 1 0																														
ID	A																														
Reset 0x00000000	0 0																														
ID	Acce Field	Value ID	Value	Description																											
A	RW	EVENTS_PWMPERIODEND		Emitted at the end of each PWM period																											
		NotGenerated	0	Event not generated																											
		Generated	1	Event generated																											

6.12.5.8 EVENTS_LOOPSDONE

Address offset: 0x11C

Concatenated sequences have been played the amount of times defined in LOOP.CNT

Bit number	31 30 29 28 27 26 25 24 23 22 21 20 19 18 17 16 15 14 13 12 11 10 9 8 7 6 5 4 3 2 1 0																														
ID	A																														
Reset 0x00000000	0 0																														
ID	Acce Field	Value ID	Value	Description																											
A	RW	EVENTS_LOOPSDONE		Concatenated sequences have been played the amount of times defined in LOOP.CNT																											
		NotGenerated	0	Event not generated																											
		Generated	1	Event generated																											

6.12.5.9 SHORTS

Address offset: 0x200

Shortcuts between local events and tasks

Bit number	31 30 29 28 27 26 25 24 23 22 21 20 19 18 17 16 15 14 13 12 11 10 9 8 7 6 5 4 3 2 1 0																														
ID	E D C B A																														
Reset 0x00000000	0 0																														
ID	Acce Field	Value ID	Value	Description																											
A	RW	SEQEND0_STOP		Shortcut between event SEQEND[0] and task STOP																											
		Disabled	0	Disable shortcut																											
		Enabled	1	Enable shortcut																											
B	RW	SEQEND1_STOP		Shortcut between event SEQEND[1] and task STOP																											
		Disabled	0	Disable shortcut																											
		Enabled	1	Enable shortcut																											
C	RW	LOOPSDONE_SEQSTART0		Shortcut between event LOOPSDONE and task SEQSTART[0]																											
		Disabled	0	Disable shortcut																											
		Enabled	1	Enable shortcut																											
D	RW	LOOPSDONE_SEQSTART1		Shortcut between event LOOPSDONE and task SEQSTART[1]																											
		Disabled	0	Disable shortcut																											
		Enabled	1	Enable shortcut																											
E	RW	LOOPSDONE_STOP		Shortcut between event LOOPSDONE and task STOP																											
		Disabled	0	Disable shortcut																											
		Enabled	1	Enable shortcut																											

6.12.5.10 INTEN

Address offset: 0x300

Enable or disable interrupt

Bit number	31 30 29 28 27 26 25 24 23 22 21 20 19 18 17 16 15 14 13 12 11 10 9 8 7 6 5 4 3 2 1 0																																		
ID																													H	G	F	E	D	C	B
Reset 0x00000000	0 0																																		
ID	Acce	Field	Value	ID	Value	Description																													
B	RW	STOPPED				Enable or disable interrupt for event STOPPED																													
			Disabled	0	Disable																														
			Enabled	1	Enable																														
C-D	RW	SEQSTARTED[i] (i=0..1)				Enable or disable interrupt for event SEQSTARTED[i]																													
			Disabled	0	Disable																														
			Enabled	1	Enable																														
E-F	RW	SEQEND[i] (i=0..1)				Enable or disable interrupt for event SEQEND[i]																													
			Disabled	0	Disable																														
			Enabled	1	Enable																														
G	RW	PWMPERIODEND				Enable or disable interrupt for event PWMPERIODEND																													
			Disabled	0	Disable																														
			Enabled	1	Enable																														
H	RW	LOOPSDONE				Enable or disable interrupt for event LOOPSDONE																													
			Disabled	0	Disable																														
			Enabled	1	Enable																														

6.12.5.11 INTENSET

Address offset: 0x304

Enable interrupt

Bit number	31 30 29 28 27 26 25 24 23 22 21 20 19 18 17 16 15 14 13 12 11 10 9 8 7 6 5 4 3 2 1 0																																		
ID																													H	G	F	E	D	C	B
Reset 0x00000000	0 0																																		
ID	Acce	Field	Value	ID	Value	Description																													
B	RW	STOPPED				Write '1' to enable interrupt for event STOPPED																													
			Set	1	Enable																														
			Disabled	0	Read: Disabled																														
			Enabled	1	Read: Enabled																														
C-D	RW	SEQSTARTED[i] (i=0..1)				Write '1' to enable interrupt for event SEQSTARTED[i]																													
			Set	1	Enable																														
			Disabled	0	Read: Disabled																														
			Enabled	1	Read: Enabled																														
E-F	RW	SEQEND[i] (i=0..1)				Write '1' to enable interrupt for event SEQEND[i]																													
			Set	1	Enable																														
			Disabled	0	Read: Disabled																														
			Enabled	1	Read: Enabled																														
G	RW	PWMPERIODEND				Write '1' to enable interrupt for event PWMPERIODEND																													
			Set	1	Enable																														
			Disabled	0	Read: Disabled																														
			Enabled	1	Read: Enabled																														
H	RW	LOOPSDONE				Write '1' to enable interrupt for event LOOPSDONE																													
			Set	1	Enable																														
			Disabled	0	Read: Disabled																														

Bit number	31	30	29	28	27	26	25	24	23	22	21	20	19	18	17	16	15	14	13	12	11	10	9	8	7	6	5	4	3	2	1	0	
ID																											H	G	F	E	D	C	B
Reset 0x00000000	0 0																																
ID	Acce Field	Value ID	Value	Description																													
		Enabled	1	Read: Enabled																													

6.12.5.12 INTENCLR

Address offset: 0x308

Disable interrupt

Bit number	31	30	29	28	27	26	25	24	23	22	21	20	19	18	17	16	15	14	13	12	11	10	9	8	7	6	5	4	3	2	1	0	
ID																											H	G	F	E	D	C	B
Reset 0x00000000	0 0																																
ID	Acce Field	Value ID	Value	Description																													
B	RW STOPPED			Write '1' to disable interrupt for event STOPPED																													
		Clear	1	Disable																													
		Disabled	0	Read: Disabled																													
		Enabled	1	Read: Enabled																													
C-D	RW SEQSTARTED[i] (i=0..1)			Write '1' to disable interrupt for event SEQSTARTED[i]																													
		Clear	1	Disable																													
		Disabled	0	Read: Disabled																													
		Enabled	1	Read: Enabled																													
E-F	RW SEQEND[i] (i=0..1)			Write '1' to disable interrupt for event SEQEND[i]																													
		Clear	1	Disable																													
		Disabled	0	Read: Disabled																													
		Enabled	1	Read: Enabled																													
G	RW PWMPERIODEND			Write '1' to disable interrupt for event PWMPERIODEND																													
		Clear	1	Disable																													
		Disabled	0	Read: Disabled																													
		Enabled	1	Read: Enabled																													
H	RW LOOPSDONE			Write '1' to disable interrupt for event LOOPSDONE																													
		Clear	1	Disable																													
		Disabled	0	Read: Disabled																													
		Enabled	1	Read: Enabled																													

6.12.5.13 ENABLE

Address offset: 0x500

PWM module enable register

Bit number	31	30	29	28	27	26	25	24	23	22	21	20	19	18	17	16	15	14	13	12	11	10	9	8	7	6	5	4	3	2	1	0
ID																											A					
Reset 0x00000000	0 0																															
ID	Acce Field	Value ID	Value	Description																												
A	RW ENABLE			Enable or disable PWM module																												
		Disabled	0	Disabled																												
		Enabled	1	Enable																												

6.12.5.14 MODE

Address offset: 0x504

Selects operating mode of the wave counter

Bit number	31	30	29	28	27	26	25	24	23	22	21	20	19	18	17	16	15	14	13	12	11	10	9	8	7	6	5	4	3	2	1	0
ID																																A
Reset	0x00000000																															
Reset	0	0	0	0	0	0	0	0	0	0	0	0	0	0	0	0	0	0	0	0	0	0	0	0	0	0	0	0	0	0	0	0
ID	Acce	Field	Value ID	Value	Description																											
A	RW	UPDOWN			Selects up mode or up-and-down mode for the counter																											
			Up	0	Up counter, edge-aligned PWM duty cycle																											
			UpAndDown	1	Up and down counter, center-aligned PWM duty cycle																											

6.12.5.15 COUNTERTOP

Address offset: 0x508

Value up to which the pulse generator counter counts

Bit number	31	30	29	28	27	26	25	24	23	22	21	20	19	18	17	16	15	14	13	12	11	10	9	8	7	6	5	4	3	2	1	0																								
ID																													A	A	A	A	A	A	A	A	A	A	A	A	A	A	A	A	A	A	A	A	A	A	A	A	A	A	A	A
Reset	0x000003FF																																																							
Reset	0	0	0	0	0	0	0	0	0	0	0	0	0	0	0	0	0	0	0	0	0	0	0	0	1	1	1	1	1	1	1	1																								
ID	Acce	Field	Value ID	Value	Description																																																			
A	RW	COUNTERTOP		[3..32767]	Value up to which the pulse generator counter counts. This register is ignored when DECODER.MODE=WaveForm and only values from RAM are used.																																																			

6.12.5.16 PRESCALER

Address offset: 0x50C

Configuration for PWM_CLK

Bit number	31	30	29	28	27	26	25	24	23	22	21	20	19	18	17	16	15	14	13	12	11	10	9	8	7	6	5	4	3	2	1	0
ID																													A	A	A	
Reset	0x00000000																															
Reset	0	0	0	0	0	0	0	0	0	0	0	0	0	0	0	0	0	0	0	0	0	0	0	0	0	0	0	0	0	0	0	
ID	Acce	Field	Value ID	Value	Description																											
A	RW	PRESCALER			Prescaler of PWM_CLK																											
			DIV_1	0	Divide by 1 (16 MHz)																											
			DIV_2	1	Divide by 2 (8 MHz)																											
			DIV_4	2	Divide by 4 (4 MHz)																											
			DIV_8	3	Divide by 8 (2 MHz)																											
			DIV_16	4	Divide by 16 (1 MHz)																											
			DIV_32	5	Divide by 32 (500 kHz)																											
			DIV_64	6	Divide by 64 (250 kHz)																											
			DIV_128	7	Divide by 128 (125 kHz)																											

6.12.5.17 DECODER

Address offset: 0x510

Configuration of the decoder

Bit number	31 30 29 28 27 26 25 24 23 22 21 20 19 18 17 16 15 14 13 12 11 10 9 8 7 6 5 4 3 2 1 0																															
ID																													B		A	A
Reset 0x00000000	0 0																															
ID	Acce Field	Value ID	Value	Description																												
A	RW LOAD			How a sequence is read from RAM and spread to the compare register																												
		Common	0	1st half word (16-bit) used in all PWM channels 0..3																												
		Grouped	1	1st half word (16-bit) used in channel 0..1; 2nd word in channel 2..3																												
		Individual	2	1st half word (16-bit) in ch.0; 2nd in ch.1; ...; 4th in ch.3																												
		WaveForm	3	1st half word (16-bit) in ch.0; 2nd in ch.1; ...; 4th in COUNTERTOP																												
B	RW MODE			Selects source for advancing the active sequence																												
		RefreshCount	0	SEQ[n].REFRESH is used to determine loading internal compare registers																												
		NextStep	1	NEXTSTEP task causes a new value to be loaded to internal compare registers																												

6.12.5.18 LOOP

Address offset: 0x514

Number of playbacks of a loop

Bit number	31 30 29 28 27 26 25 24 23 22 21 20 19 18 17 16 15 14 13 12 11 10 9 8 7 6 5 4 3 2 1 0																																																							
ID																													A		A	A	A	A	A	A	A	A	A	A	A	A	A	A	A	A	A	A	A	A	A	A	A	A	A	A
Reset 0x00000000	0 0																																																							
ID	Acce Field	Value ID	Value	Description																																																				
A	RW CNT			Number of playbacks of pattern cycles																																																				
		Disabled	0	Looping disabled (stop at the end of the sequence)																																																				

6.12.5.19 SEQ[n].PTR (n=0..1)

Address offset: 0x520 + (n × 0x20)

Beginning address in RAM of this sequence

Bit number	31 30 29 28 27 26 25 24 23 22 21 20 19 18 17 16 15 14 13 12 11 10 9 8 7 6 5 4 3 2 1 0																																																							
ID	A																												A		A	A	A	A	A	A	A	A	A	A	A	A	A	A	A	A	A	A	A	A	A	A	A	A	A	A
Reset 0x00000000	0 0																																																							
ID	Acce Field	Value ID	Value	Description																																																				
A	RW PTR			Beginning address in RAM of this sequence																																																				

Note: See the memory chapter for details about which memories are available for EasyDMA.

6.12.5.20 SEQ[n].CNT (n=0..1)

Address offset: 0x524 + (n × 0x20)

Number of values (duty cycles) in this sequence

Bit number	31	30	29	28	27	26	25	24	23	22	21	20	19	18	17	16	15	14	13	12	11	10	9	8	7	6	5	4	3	2	1	0																			
ID																					A	A	A	A	A	A	A	A	A	A	A	A	A	A	A	A	A	A	A	A	A	A	A	A	A	A	A	A	A	A	
Reset 0x00000000																					0	0	0	0	0	0	0	0	0	0	0	0	0	0	0	0	0	0	0	0	0	0	0	0	0	0	0	0	0	0	0
ID	Acce Field	Value ID	Value	Description																																															
A	RW CNT	Disabled	0	Number of values (duty cycles) in this sequence Sequence is disabled, and shall not be started as it is empty																																															

6.12.5.21 SEQ[n].REFRESH (n=0..1)

Address offset: 0x528 + (n × 0x20)

Number of additional PWM periods between samples loaded into compare register

Bit number	31	30	29	28	27	26	25	24	23	22	21	20	19	18	17	16	15	14	13	12	11	10	9	8	7	6	5	4	3	2	1	0																			
ID																					A	A	A	A	A	A	A	A	A	A	A	A	A	A	A	A	A	A	A	A	A	A	A	A	A	A	A	A	A	A	
Reset 0x00000001																					0	0	0	0	0	0	0	0	0	0	0	0	0	0	0	0	0	0	0	0	0	0	0	0	0	0	0	0	0	0	1
ID	Acce Field	Value ID	Value	Description																																															
A	RW CNT	Continuous	0	Number of additional PWM periods between samples loaded into compare register (load every REFRESH.CNT+1 PWM periods) Update every PWM period																																															

6.12.5.22 SEQ[n].ENDDelay (n=0..1)

Address offset: 0x52C + (n × 0x20)

Time added after the sequence

Bit number	31	30	29	28	27	26	25	24	23	22	21	20	19	18	17	16	15	14	13	12	11	10	9	8	7	6	5	4	3	2	1	0																			
ID																					A	A	A	A	A	A	A	A	A	A	A	A	A	A	A	A	A	A	A	A	A	A	A	A	A	A	A	A	A	A	
Reset 0x00000000																					0	0	0	0	0	0	0	0	0	0	0	0	0	0	0	0	0	0	0	0	0	0	0	0	0	0	0	0	0	0	0
ID	Acce Field	Value ID	Value	Description																																															
A	RW CNT			Time added after the sequence in PWM periods																																															

6.12.5.23 PSEL.OUT[n] (n=0..3)

Address offset: 0x560 + (n × 0x4)

Output pin select for PWM channel n

Bit number	31	30	29	28	27	26	25	24	23	22	21	20	19	18	17	16	15	14	13	12	11	10	9	8	7	6	5	4	3	2	1	0																	
ID	C																				A				A	A	A	A																					
Reset 0xFFFFFFFF	1																				1	1	1	1	1	1	1	1	1	1	1	1	1	1	1	1	1	1	1	1	1	1	1	1	1	1	1	1	1
ID	Acce Field	Value ID	Value	Description																																													
A	RW PIN		[0..31]	Pin number																																													
C	RW CONNECT	Disconnected	1	Disconnect																																													
		Connected	0	Connect																																													

6.13 QDEC — Quadrature decoder

The Quadrature decoder (QDEC) provides buffered decoding of quadrature-encoded sensor signals. It is suitable for mechanical and optical sensors.

The sample period and accumulation are configurable to match application requirements. The QDEC provides the following:

- Decoding of digital waveform from off-chip quadrature encoder.
- Sample accumulation eliminating hard real-time requirements to be enforced on application.
- Optional input de-bounce filters.
- Optional LED output signal for optical encoders.

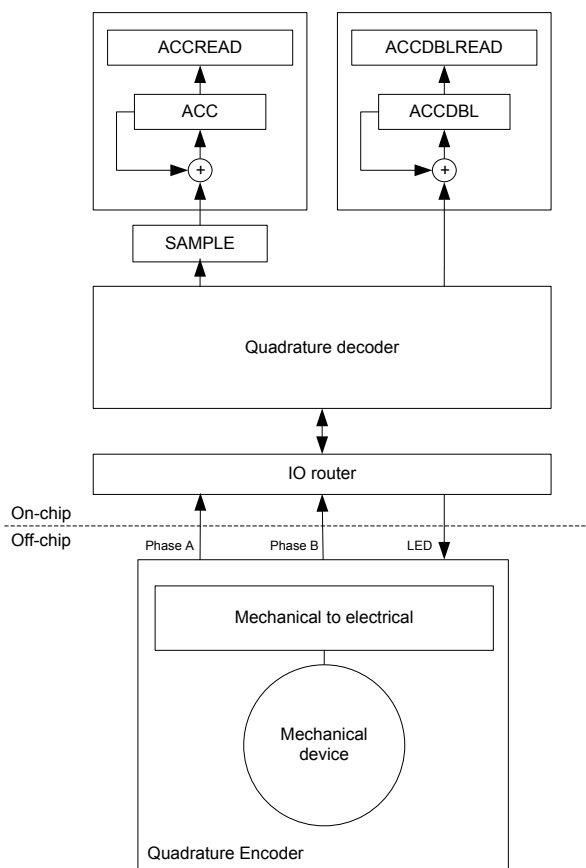

Figure 56: Quadrature decoder configuration

6.13.1 Sampling and decoding

The QDEC decodes the output from an incremental motion encoder by sampling the QDEC phase input pins (A and B).

The off-chip quadrature encoder is an incremental motion encoder outputting two waveforms, phase A and phase B. The two output waveforms are always 90 degrees out of phase, meaning that one always changes level before the other. The direction of movement is indicated by which of these two waveforms that changes level first. Invalid transitions may occur, that is when the two waveforms switch simultaneously. This may occur if the wheel rotates too fast relative to the sample rate set for the decoder.

The QDEC decodes the output from the off-chip encoder by sampling the QDEC phase input pins (A and B) at a fixed rate as specified in the SAMPLEPER register.

If the SAMPLEPER value needs to be changed, the QDEC shall be stopped using the STOP task. SAMPLEPER can be then changed upon receiving the STOPPED event, and QDEC can be restarted using the START task. Failing to do so may result in unpredictable behaviour.

It is good practice to change other registers (LEDPOL, REPORTPER, DBFEN and LEDPRE) only when the QDEC is stopped.

When started, the decoder continuously samples the two input waveforms and decodes these by comparing the current sample pair (n) with the previous sample pair (n-1).

The decoding of the sample pairs is described in the table below.

Previous sample pair(n-1)		Current samples pair(n)		SAMPLE register	ACC operation	ACCDBL operation	Description
A	B	A	B				
0	0	0	0	0	No change	No change	No movement
0	0	0	1	1	Increment	No change	Movement in positive direction
0	0	1	0	-1	Decrement	No change	Movement in negative direction
0	0	1	1	2	No change	Increment	Error: Double transition
0	1	0	0	-1	Decrement	No change	Movement in negative direction
0	1	0	1	0	No change	No change	No movement
0	1	1	0	2	No change	Increment	Error: Double transition
0	1	1	1	1	Increment	No change	Movement in positive direction
1	0	0	0	1	Increment	No change	Movement in positive direction
1	0	0	1	2	No change	Increment	Error: Double transition
1	0	1	0	0	No change	No change	No movement
1	0	1	1	-1	Decrement	No change	Movement in negative direction
1	1	0	0	2	No change	Increment	Error: Double transition
1	1	0	1	-1	Decrement	No change	Movement in negative direction
1	1	1	0	1	Increment	No change	Movement in positive direction
1	1	1	1	0	No change	No change	No movement

Table 55: Sampled value encoding

6.13.2 LED output

The LED output follows the sample period, and the LED is switched on a given period before sampling and switched off immediately after the inputs are sampled. The period the LED is switched on before sampling is given in the LEDPRE register.

The LED output pin polarity is specified in the LEDPOL register.

For using off-chip mechanical encoders not requiring a LED, the LED output can be disabled by writing value 'Disconnected' to the CONNECT field of the PSEL.LED register. In this case the QDEC will not acquire access to a LED output pin and the pin can be used for other purposes by the CPU.

6.13.3 Debounce filters

Each of the two-phase inputs have digital debounce filters.

When enabled through the DBFEN register, the filter inputs are sampled at a fixed 1 MHz frequency during the entire sample period (which is specified in the SAMPLEPER register), and the filters require all of the samples within this sample period to equal before the input signal is accepted and transferred to the output of the filter.

As a result, only input signal with a steady state longer than twice the period specified in SAMPLEPER are guaranteed to pass through the filter, and any signal with a steady state shorter than SAMPLEPER will always be suppressed by the filter. (This is assumed that the frequency during the debounce period never exceeds 500 kHz (as required by the Nyquist theorem when using a 1 MHz sample frequency).

The LED will always be ON when the debounce filters are enabled, as the inputs in this case will be sampled continuously.

Note that when the debounce filters are enabled, displacements reported by the QDEC peripheral are delayed by one SAMPLEPER period.

6.13.4 Accumulators

The quadrature decoder contains two accumulator registers, ACC and ACCDBL, that accumulate respectively valid motion sample values and the number of detected invalid samples (double transitions).

The ACC register will accumulate all valid values (1/-1) written to the SAMPLE register. This can be useful for preventing hard real-time requirements from being enforced on the application. When using the ACC register the application does not need to read every single sample from the SAMPLE register, but can instead fetch the ACC register whenever it fits the application. The ACC register will always hold the relative movement of the external mechanical device since the previous clearing of the ACC register. Sample values indicating a double transition (2) will not be accumulated in the ACC register.

An ACCOF event will be generated if the ACC receives a SAMPLE value that would cause the register to overflow or underflow. Any SAMPLE value that would cause an ACC overflow or underflow will be discarded, but any samples not causing the ACC to overflow or underflow will still be accepted.

The accumulator ACCDBL accumulates the number of detected double transitions since the previous clearing of the ACCDBL register.

The ACC and ACCDBL registers can be cleared by the READCLRACC and subsequently read using the ACCREAD and ACCDBLREAD registers.

The ACC register can be separately cleared by the RDCLRACC and subsequently read using the ACCREAD registers.

The ACCDBL register can be separately cleared by the RDCLRDBL and subsequently read using the ACCDBLREAD registers.

The REPORTPER register allows automating the capture of several samples before it can send out a REPORTRDY event in case a non-null displacement has been captured and accumulated, and a DBLRDY event in case one or more double-displacements have been captured and accumulated. The REPORTPER field in this register selects after how many samples the accumulators contents are evaluated to send (or not) REPORTRDY and DBLRDY events.

Using the RDCLRACC task (manually sent upon receiving the event, or using the DBLRDY_RDCLRACC shortcut), ACCREAD can then be read.

In case at least one double transition has been captured and accumulated, a DBLRDY event is sent. Using the RDCLRDBL task (manually sent upon receiving the event, or using the DBLRDY_RDCLRDBL shortcut), ACCDBLREAD can then be read.

6.13.5 Output/input pins

The QDEC uses a three-pin interface to the off-chip quadrature encoder.

These pins will be acquired when the QDEC is enabled in the ENABLE register. The pins acquired by the QDEC cannot be written by the CPU, but they can still be read by the CPU.

The pin numbers to be used for the QDEC are selected using the PSEL.n registers.

6.13.6 Pin configuration

The Phase A, Phase B, and LED signals are mapped to physical pins according to the configuration specified in the PSEL.A, PSEL.B, and PSEL.LED registers respectively.

If the CONNECT field value 'Disconnected' is specified in any of these registers, the associated signal will not be connected to any physical pin. The PSEL.A, PSEL.B, and PSEL.LED registers and their configurations are only used as long as the QDEC is enabled, and retained only as long as the device is in ON mode.

When the peripheral is disabled, the pins will behave as regular GPIOs, and use the configuration in their respective OUT bit field and PIN_CNF[n] register.

To secure correct behavior in the QDEC, the pins used by the QDEC must be configured in the GPIO peripheral as described in [GPIO configuration before enabling peripheral](#) on page 170 before enabling the QDEC. This configuration must be retained in the GPIO for the selected IOs as long as the QDEC is enabled.

Only one peripheral can be assigned to drive a particular GPIO pin at a time. Failing to do so may result in unpredictable behavior.

QDEC signal	QDEC pin	Direction	Output value	Comment
Phase A	As specified in PSEL.A	Input	Not applicable	
Phase B	As specified in PSEL.B	Input	Not applicable	
LED	As specified in PSEL.LED	Input	Not applicable	

Table 56: GPIO configuration before enabling peripheral

6.13.7 Registers

Base address	Peripheral	Instance	Description	Configuration
0x40012000	QDEC	QDEC	Quadrature decoder	

Table 57: Instances

Register	Offset	Description
TASKS_START	0x000	Task starting the quadrature decoder
TASKS_STOP	0x004	Task stopping the quadrature decoder
TASKS_READCLRACC	0x008	Read and clear ACC and ACCDBL
TASKS_RDCLRACC	0x00C	Read and clear ACC
TASKS_RDCLRDBL	0x010	Read and clear ACCDBL
EVENTS_SAMPLERDY	0x100	Event being generated for every new sample value written to the SAMPLE register
EVENTS_REPORTRDY	0x104	Non-null report ready
EVENTS_ACCOF	0x108	ACC or ACCDBL register overflow
EVENTS_DBLRDY	0x10C	Double displacement(s) detected
EVENTS_STOPPED	0x110	QDEC has been stopped
SHORTS	0x200	Shortcuts between local events and tasks
INTENSET	0x304	Enable interrupt
INTENCLR	0x308	Disable interrupt
ENABLE	0x500	Enable the quadrature decoder
LEDPOL	0x504	LED output pin polarity
SAMPLEPER	0x508	Sample period
SAMPLE	0x50C	Motion sample value
REPORTPER	0x510	Number of samples to be taken before REPORTRDY and DBLRDY events can be generated
ACC	0x514	Register accumulating the valid transitions
ACCREAD	0x518	Snapshot of the ACC register, updated by the READCLRACC or RDCLRACC task
PSEL.LED	0x51C	Pin select for LED signal
PSEL.A	0x520	Pin select for A signal
PSEL.B	0x524	Pin select for B signal
DBFEN	0x528	Enable input debounce filters
LEDPRE	0x540	Time period the LED is switched ON prior to sampling
ACCDBL	0x544	Register accumulating the number of detected double transitions

Register	Offset	Description
ACCDLREAD	0x548	Snapshot of the ACCDBL, updated by the READCLRACC or RDCLRDBL task

Table 58: Register overview

6.13.7.1 TASKS_START

Address offset: 0x000

Task starting the quadrature decoder

When started, the SAMPLE register will be continuously updated at the rate given in the SAMPLEPER register.

Bit number	31 30 29 28 27 26 25 24 23 22 21 20 19 18 17 16 15 14 13 12 11 10 9 8 7 6 5 4 3 2 1 0																														
ID	A																														
Reset 0x00000000	0 0																														
ID	Acce Field	Value ID	Value	Description																											
A	W	TASKS_START		Task starting the quadrature decoder																											
				When started, the SAMPLE register will be continuously updated at the rate given in the SAMPLEPER register.																											
		Trigger	1	Trigger task																											

6.13.7.2 TASKS_STOP

Address offset: 0x004

Task stopping the quadrature decoder

Bit number	31 30 29 28 27 26 25 24 23 22 21 20 19 18 17 16 15 14 13 12 11 10 9 8 7 6 5 4 3 2 1 0																														
ID	A																														
Reset 0x00000000	0 0																														
ID	Acce Field	Value ID	Value	Description																											
A	W	TASKS_STOP		Task stopping the quadrature decoder																											
		Trigger	1	Trigger task																											

6.13.7.3 TASKS_READCLRACC

Address offset: 0x008

Read and clear ACC and ACCDBL

Task transferring the content of ACC to ACCREAD and the content of ACCDBL to ACCDBLREAD, and then clearing the ACC and ACCDBL registers. These read-and-clear operations will be done atomically.

Bit number	31 30 29 28 27 26 25 24 23 22 21 20 19 18 17 16 15 14 13 12 11 10 9 8 7 6 5 4 3 2 1 0																														
ID	A																														
Reset 0x00000000	0 0																														
ID	Acce Field	Value ID	Value	Description																											
A	W	TASKS_READCLRACC		Read and clear ACC and ACCDBL																											
				Task transferring the content of ACC to ACCREAD and the content of ACCDBL to ACCDBLREAD, and then clearing the ACC and ACCDBL registers. These read-and-clear operations will be done atomically.																											
		Trigger	1	Trigger task																											

6.13.7.4 TASKS_RDCLRACC

Address offset: 0x00C

Read and clear ACC

Task transferring the content of ACC to ACCREAD, and then clearing the ACC register. This read-and-clear operation will be done atomically.

Bit number	31 30 29 28 27 26 25 24 23 22 21 20 19 18 17 16 15 14 13 12 11 10 9 8 7 6 5 4 3 2 1 0																														
ID	A																														
Reset 0x00000000	0 0																														
ID	Acce Field	Value ID	Value	Description																											
A	W	TASKS_RDCLRACC		Read and clear ACC																											
				Task transferring the content of ACC to ACCREAD, and then clearing the ACC register. This read-and-clear operation will be done atomically.																											
		Trigger	1	Trigger task																											

6.13.7.5 TASKS_RDCLRDBL

Address offset: 0x010

Read and clear ACCDBL

Task transferring the content of ACCDBL to ACCDBLREAD, and then clearing the ACCDBL register. This read-and-clear operation will be done atomically.

Bit number	31 30 29 28 27 26 25 24 23 22 21 20 19 18 17 16 15 14 13 12 11 10 9 8 7 6 5 4 3 2 1 0																														
ID	A																														
Reset 0x00000000	0 0																														
ID	Acce Field	Value ID	Value	Description																											
A	W	TASKS_RDCLRDBL		Read and clear ACCDBL																											
				Task transferring the content of ACCDBL to ACCDBLREAD, and then clearing the ACCDBL register. This read-and-clear operation will be done atomically.																											
		Trigger	1	Trigger task																											

6.13.7.6 EVENTS_SAMPLERDY

Address offset: 0x100

Event being generated for every new sample value written to the SAMPLE register

Bit number	31 30 29 28 27 26 25 24 23 22 21 20 19 18 17 16 15 14 13 12 11 10 9 8 7 6 5 4 3 2 1 0																														
ID	A																														
Reset 0x00000000	0 0																														
ID	Acce Field	Value ID	Value	Description																											
A	RW	EVENTS_SAMPLERDY		Event being generated for every new sample value written to the SAMPLE register																											
		NotGenerated	0	Event not generated																											
		Generated	1	Event generated																											

6.13.7.7 EVENTS_REPORTRDY

Address offset: 0x104

Non-null report ready

Event generated when REPORTPER number of samples has been accumulated in the ACC register and the content of the ACC register is not equal to 0. (Thus, this event is only generated if a motion is detected since the previous clearing of the ACC register).

Bit number	31 30 29 28 27 26 25 24 23 22 21 20 19 18 17 16 15 14 13 12 11 10 9 8 7 6 5 4 3 2 1 0																														
ID	A																														
Reset	0x00000000																														
Reset	0 0																														
ID	Acce Field	Value ID	Value	Description																											
A	RW	EVENTS_REPORTRDY		Non-null report ready																											
				Event generated when REPORTPER number of samples has been accumulated in the ACC register and the content of the ACC register is not equal to 0. (Thus, this event is only generated if a motion is detected since the previous clearing of the ACC register).																											
		NotGenerated	0	Event not generated																											
		Generated	1	Event generated																											

6.13.7.8 EVENTS_ACCOF

Address offset: 0x108

ACC or ACCDBL register overflow

Bit number	31 30 29 28 27 26 25 24 23 22 21 20 19 18 17 16 15 14 13 12 11 10 9 8 7 6 5 4 3 2 1 0																														
ID	A																														
Reset	0x00000000																														
Reset	0 0																														
ID	Acce Field	Value ID	Value	Description																											
A	RW	EVENTS_ACCOF		ACC or ACCDBL register overflow																											
		NotGenerated	0	Event not generated																											
		Generated	1	Event generated																											

6.13.7.9 EVENTS_DBLRDY

Address offset: 0x10C

Double displacement(s) detected

Event generated when REPORTPER number of samples has been accumulated and the content of the ACCDBL register is not equal to 0. (Thus, this event is only generated if a double transition is detected since the previous clearing of the ACCDBL register).

Bit number	31 30 29 28 27 26 25 24 23 22 21 20 19 18 17 16 15 14 13 12 11 10 9 8 7 6 5 4 3 2 1 0																														
ID	A																														
Reset 0x00000000	0 0																														
ID	Acce Field	Value ID	Value	Description																											
A	RW	EVENTS_DBLRDY		Double displacement(s) detected																											
				Event generated when REPORTPER number of samples has been accumulated and the content of the ACCDBL register is not equal to 0. (Thus, this event is only generated if a double transition is detected since the previous clearing of the ACCDBL register).																											
		NotGenerated	0	Event not generated																											
		Generated	1	Event generated																											

6.13.7.10 EVENTS_STOPPED

Address offset: 0x110

QDEC has been stopped

Bit number	31 30 29 28 27 26 25 24 23 22 21 20 19 18 17 16 15 14 13 12 11 10 9 8 7 6 5 4 3 2 1 0																														
ID	A																														
Reset 0x00000000	0 0																														
ID	Acce Field	Value ID	Value	Description																											
A	RW	EVENTS_STOPPED		QDEC has been stopped																											
		NotGenerated	0	Event not generated																											
		Generated	1	Event generated																											

6.13.7.11 SHORTS

Address offset: 0x200

Shortcuts between local events and tasks

Bit number	31 30 29 28 27 26 25 24 23 22 21 20 19 18 17 16 15 14 13 12 11 10 9 8 7 6 5 4 3 2 1 0																														
ID	G F E D C B A																														
Reset 0x00000000	0 0																														
ID	Acce Field	Value ID	Value	Description																											
A	RW	REPORTRDY_READCLRACC		Shortcut between event REPORTRDY and task READCLRACC																											
		Disabled	0	Disable shortcut																											
		Enabled	1	Enable shortcut																											
B	RW	SAMPLERDY_STOP		Shortcut between event SAMPLERDY and task STOP																											
		Disabled	0	Disable shortcut																											
		Enabled	1	Enable shortcut																											
C	RW	REPORTRDY_RDCLRACC		Shortcut between event REPORTRDY and task RDCLRACC																											
		Disabled	0	Disable shortcut																											
		Enabled	1	Enable shortcut																											
D	RW	REPORTRDY_STOP		Shortcut between event REPORTRDY and task STOP																											
		Disabled	0	Disable shortcut																											
		Enabled	1	Enable shortcut																											
E	RW	DBLRDY_RDCLRDBL		Shortcut between event DBLRDY and task RDCLRDBL																											
		Disabled	0	Disable shortcut																											
		Enabled	1	Enable shortcut																											
F	RW	DBLRDY_STOP		Shortcut between event DBLRDY and task STOP																											
		Disabled	0	Disable shortcut																											

Bit number	31 30 29 28 27 26 25 24 23 22 21 20 19 18 17 16 15 14 13 12 11 10 9 8 7 6 5 4 3 2 1 0																																				
ID																															G	F	E	D	C	B	A
Reset 0x00000000	0 0																																				
ID	Acce Field	Value ID	Value	Description																																	
		Enabled	1	Enable shortcut																																	
G	RW SAMPLERDY_READCLRACC			Shortcut between event SAMPLERDY and task READCLRACC																																	
		Disabled	0	Disable shortcut																																	
		Enabled	1	Enable shortcut																																	

6.13.7.12 INTENSET

Address offset: 0x304

Enable interrupt

Bit number	31 30 29 28 27 26 25 24 23 22 21 20 19 18 17 16 15 14 13 12 11 10 9 8 7 6 5 4 3 2 1 0																																		
ID																															E	D	C	B	A
Reset 0x00000000	0 0																																		
ID	Acce Field	Value ID	Value	Description																															
A	RW SAMPLERDY			Write '1' to enable interrupt for event SAMPLERDY																															
		Set	1	Enable																															
		Disabled	0	Read: Disabled																															
		Enabled	1	Read: Enabled																															
B	RW REPORTRDY			Write '1' to enable interrupt for event REPORTRDY																															
				Event generated when REPORTPER number of samples has been accumulated in the ACC register and the content of the ACC register is not equal to 0. (Thus, this event is only generated if a motion is detected since the previous clearing of the ACC register).																															
		Set	1	Enable																															
		Disabled	0	Read: Disabled																															
		Enabled	1	Read: Enabled																															
C	RW ACCOF			Write '1' to enable interrupt for event ACCOF																															
		Set	1	Enable																															
		Disabled	0	Read: Disabled																															
		Enabled	1	Read: Enabled																															
D	RW DBLRDY			Write '1' to enable interrupt for event DBLRDY																															
				Event generated when REPORTPER number of samples has been accumulated and the content of the ACCDBL register is not equal to 0. (Thus, this event is only generated if a double transition is detected since the previous clearing of the ACCDBL register).																															
		Set	1	Enable																															
		Disabled	0	Read: Disabled																															
		Enabled	1	Read: Enabled																															
E	RW STOPPED			Write '1' to enable interrupt for event STOPPED																															
		Set	1	Enable																															
		Disabled	0	Read: Disabled																															
		Enabled	1	Read: Enabled																															

6.13.7.13 INTENCLR

Address offset: 0x308

Disable interrupt

Bit number	31 30 29 28 27 26 25 24 23 22 21 20 19 18 17 16 15 14 13 12 11 10 9 8 7 6 5 4 3 2 1 0																														
ID																															E D C B A
Reset 0x00000000	0 0																														
ID	Acce Field	Value ID	Value	Description																											
A	RW SAMPLERDY			Write '1' to disable interrupt for event SAMPLERDY																											
		Clear	1	Disable																											
		Disabled	0	Read: Disabled																											
		Enabled	1	Read: Enabled																											
		B	RW REPORTRDY			Write '1' to disable interrupt for event REPORTRDY																									
						Event generated when REPORTPER number of samples has been accumulated in the ACC register and the content of the ACC register is not equal to 0. (Thus, this event is only generated if a motion is detected since the previous clearing of the ACC register).																									
Clear	1			Disable																											
		Disabled	0	Read: Disabled																											
		Enabled	1	Read: Enabled																											
		C	RW ACCOF			Write '1' to disable interrupt for event ACCOF																									
Clear	1			Disable																											
Disabled	0			Read: Disabled																											
		Enabled	1	Read: Enabled																											
		D	RW DBLRDY			Write '1' to disable interrupt for event DBLRDY																									
						Event generated when REPORTPER number of samples has been accumulated and the content of the ACCDBL register is not equal to 0. (Thus, this event is only generated if a double transition is detected since the previous clearing of the ACCDBL register).																									
Clear	1			Disable																											
		Disabled	0	Read: Disabled																											
		Enabled	1	Read: Enabled																											
		E	RW STOPPED			Write '1' to disable interrupt for event STOPPED																									
Clear	1			Disable																											
Disabled	0			Read: Disabled																											
		Enabled	1	Read: Enabled																											

6.13.7.14 ENABLE

Address offset: 0x500

Enable the quadrature decoder

Bit number	31 30 29 28 27 26 25 24 23 22 21 20 19 18 17 16 15 14 13 12 11 10 9 8 7 6 5 4 3 2 1 0																														
ID																															A
Reset 0x00000000	0 0																														
ID	Acce Field	Value ID	Value	Description																											
A	RW ENABLE			Enable or disable the quadrature decoder																											
				When enabled the decoder pins will be active. When disabled the quadrature decoder pins are not active and can be used as GPIO .																											
		Disabled	0	Disable																											
		Enabled	1	Enable																											

6.13.7.15 LEDPOL

Address offset: 0x504

LED output pin polarity

Bit number	31	30	29	28	27	26	25	24	23	22	21	20	19	18	17	16	15	14	13	12	11	10	9	8	7	6	5	4	3	2	1	0
ID																																A
Reset 0x00000000	0																															
ID	Acce Field	Value ID	Value	Description																												
A	RW LEDPOL			LED output pin polarity																												
		ActiveLow	0	Led active on output pin low																												
		ActiveHigh	1	Led active on output pin high																												

6.13.7.16 SAMPLEPER

Address offset: 0x508

Sample period

Bit number	31	30	29	28	27	26	25	24	23	22	21	20	19	18	17	16	15	14	13	12	11	10	9	8	7	6	5	4	3	2	1	0			
ID																																A	A	A	A
Reset 0x00000000	0																																		
ID	Acce Field	Value ID	Value	Description																															
A	RW SAMPLEPER			Sample period. The SAMPLE register will be updated for every new sample																															
		128us	0	128 us																															
		256us	1	256 us																															
		512us	2	512 us																															
		1024us	3	1024 us																															
		2048us	4	2048 us																															
		4096us	5	4096 us																															
		8192us	6	8192 us																															
		16384us	7	16384 us																															
		32ms	8	32768 us																															
		65ms	9	65536 us																															
		131ms	10	131072 us																															

6.13.7.17 SAMPLE

Address offset: 0x50C

Motion sample value

Bit number	31	30	29	28	27	26	25	24	23	22	21	20	19	18	17	16	15	14	13	12	11	10	9	8	7	6	5	4	3	2	1	0
ID	A	A	A	A	A	A	A	A	A	A	A	A	A	A	A	A	A	A	A	A	A	A	A	A	A	A	A	A	A	A	A	
Reset 0x00000000	0																															
ID	Acce Field	Value ID	Value	Description																												
A	R SAMPLE		[-1..2]	Last motion sample																												
				The value is a 2's complement value, and the sign gives the direction of the motion. The value '2' indicates a double transition.																												

6.13.7.18 REPORTPER

Address offset: 0x510

Number of samples to be taken before REPORTRDY and DBLRDY events can be generated

Bit number	31 30 29 28 27 26 25 24 23 22 21 20 19 18 17 16 15 14 13 12 11 10 9 8 7 6 5 4 3 2 1 0																																		
ID																																A	A	A	A
Reset 0x00000000	0 0																																		
ID	Acce Field	Value ID	Value	Description																															
A	RW	REPORTPER		Specifies the number of samples to be accumulated in the ACC register before the REPORTRDY and DBLRDY events can be generated																															
				The report period in [us] is given as: $RPUS = SP * RP$ Where RPUS is the report period in [us/report], SP is the sample period in [us/sample] specified in SAMPLEPER, and RP is the report period in [samples/report] specified in REPORTPER .																															
		10Smpl	0	10 samples / report																															
		40Smpl	1	40 samples / report																															
		80Smpl	2	80 samples / report																															
		120Smpl	3	120 samples / report																															
		160Smpl	4	160 samples / report																															
		200Smpl	5	200 samples / report																															
		240Smpl	6	240 samples / report																															
		280Smpl	7	280 samples / report																															
		1Smpl	8	1 sample / report																															

6.13.7.19 ACC

Address offset: 0x514

Register accumulating the valid transitions

Bit number	31 30 29 28 27 26 25 24 23 22 21 20 19 18 17 16 15 14 13 12 11 10 9 8 7 6 5 4 3 2 1 0																																																											
ID	A																															A	A	A	A	A	A	A	A	A	A	A	A	A	A	A	A	A	A	A	A	A	A	A	A	A	A	A	A	A
Reset 0x00000000	0 0																																																											
ID	Acce Field	Value ID	Value	Description																																																								
A	R	ACC	[-1024..1023]	Register accumulating all valid samples (not double transition) read from the SAMPLE register																																																								
				Double transitions (SAMPLE = 2) will not be accumulated in this register. The value is a 32 bit 2's complement value.																																																								
				If a sample that would cause this register to overflow or underflow is received, the sample will be ignored and an overflow event (ACCOF) will be generated. The ACC register is cleared by triggering the READCLRACC or the RDCLRACC task.																																																								

6.13.7.20 ACCREAD

Address offset: 0x518

Snapshot of the ACC register, updated by the READCLRACC or RDCLRACC task

Bit number	31	30	29	28	27	26	25	24	23	22	21	20	19	18	17	16	15	14	13	12	11	10	9	8	7	6	5	4	3	2	1	0	
ID	A	A	A	A	A	A	A	A	A	A	A	A	A	A	A	A	A	A	A	A	A	A	A	A	A	A	A	A	A	A	A	A	A
Reset 0x00000000	0	0	0	0	0	0	0	0	0	0	0	0	0	0	0	0	0	0	0	0	0	0	0	0	0	0	0	0	0	0	0	0	
ID	Acce Field	Value ID	Value	Description																													
A	R	ACCREAD	[-1024..1023]	Snapshot of the ACC register. The ACCREAD register is updated when the READCLRACC or RDCLRACC task is triggered																													

6.13.7.21 PSEL.LED

Address offset: 0x51C

Pin select for LED signal

Bit number	31	30	29	28	27	26	25	24	23	22	21	20	19	18	17	16	15	14	13	12	11	10	9	8	7	6	5	4	3	2	1	0	
ID	C																												A	A	A	A	A
Reset 0xFFFFFFFF	1	1	1	1	1	1	1	1	1	1	1	1	1	1	1	1	1	1	1	1	1	1	1	1	1	1	1	1	1	1	1	1	
ID	Acce Field	Value ID	Value	Description																													
A	RW	PIN	[0..31]	Pin number																													
C	RW	CONNECT		Connection																													
		Disconnected	1	Disconnect																													
		Connected	0	Connect																													

6.13.7.22 PSEL.A

Address offset: 0x520

Pin select for A signal

Bit number	31	30	29	28	27	26	25	24	23	22	21	20	19	18	17	16	15	14	13	12	11	10	9	8	7	6	5	4	3	2	1	0	
ID	C																												A	A	A	A	A
Reset 0xFFFFFFFF	1	1	1	1	1	1	1	1	1	1	1	1	1	1	1	1	1	1	1	1	1	1	1	1	1	1	1	1	1	1	1	1	
ID	Acce Field	Value ID	Value	Description																													
A	RW	PIN	[0..31]	Pin number																													
C	RW	CONNECT		Connection																													
		Disconnected	1	Disconnect																													
		Connected	0	Connect																													

6.13.7.23 PSEL.B

Address offset: 0x524

Pin select for B signal

Bit number	31	30	29	28	27	26	25	24	23	22	21	20	19	18	17	16	15	14	13	12	11	10	9	8	7	6	5	4	3	2	1	0	
ID	C																												A	A	A	A	A
Reset 0xFFFFFFFF	1	1	1	1	1	1	1	1	1	1	1	1	1	1	1	1	1	1	1	1	1	1	1	1	1	1	1	1	1	1	1	1	
ID	Acce Field	Value ID	Value	Description																													
A	RW	PIN	[0..31]	Pin number																													
C	RW	CONNECT		Connection																													
		Disconnected	1	Disconnect																													
		Connected	0	Connect																													

6.13.7.24 DBFEN

Address offset: 0x528

Enable input debounce filters

Bit number	31 30 29 28 27 26 25 24 23 22 21 20 19 18 17 16 15 14 13 12 11 10 9 8 7 6 5 4 3 2 1 0																														
ID																															A
Reset 0x00000000	0 0																														
ID	Acce Field	Value ID	Value	Description																											
A	RW DBFEN			Enable input debounce filters																											
		Disabled	0	Debounce input filters disabled																											
		Enabled	1	Debounce input filters enabled																											

6.13.7.25 LEDPRE

Address offset: 0x540

Time period the LED is switched ON prior to sampling

Bit number	31 30 29 28 27 26 25 24 23 22 21 20 19 18 17 16 15 14 13 12 11 10 9 8 7 6 5 4 3 2 1 0																																																							
ID																													A	A	A	A	A	A	A	A	A	A	A	A	A	A	A	A	A	A	A	A	A	A	A	A	A	A	A	A
Reset 0x00000010	0 1 0 0 0 0																																																							
ID	Acce Field	Value ID	Value	Description																																																				
A	RW LEDPRE		[1..511]	Period in us the LED is switched on prior to sampling																																																				

6.13.7.26 ACCDBL

Address offset: 0x544

Register accumulating the number of detected double transitions

Bit number	31 30 29 28 27 26 25 24 23 22 21 20 19 18 17 16 15 14 13 12 11 10 9 8 7 6 5 4 3 2 1 0																															
ID																													A	A	A	A
Reset 0x00000000	0 0																															
ID	Acce Field	Value ID	Value	Description																												
A	R ACCDBL		[0..15]	Register accumulating the number of detected double or illegal transitions. (SAMPLE = 2).																												
				When this register has reached its maximum value the accumulation of double / illegal transitions will stop. An overflow event (ACCOF) will be generated if any double or illegal transitions are detected after the maximum value was reached. This field is cleared by triggering the READCLRACC or RDCLRDBL task.																												

6.13.7.27 ACCDBLREAD

Address offset: 0x548

Snapshot of the ACCDBL, updated by the READCLRACC or RDCLRDBL task

Bit number	31	30	29	28	27	26	25	24	23	22	21	20	19	18	17	16	15	14	13	12	11	10	9	8	7	6	5	4	3	2	1	0
ID	A A A A																															
Reset 0x00000000	0 0																															
ID	Acce Field	Value ID	Value	Description																												
A	R	ACCLBLREAD	[0..15]	Snapshot of the ACCDBL register. This field is updated when the READCLRACC or RDCLRDBL task is triggered.																												

6.13.8 Electrical specification

6.13.8.1 QDEC Electrical Specification

Symbol	Description	Min.	Typ.	Max.	Units
t _{SAMPLE}	Time between sampling signals from quadrature decoder	128		131072	μs
t _{LED}	Time from LED is turned on to signals are sampled	0		511	μs

6.14 RADIO — 2.4 GHz radio

The 2.4 GHz radio transceiver is compatible with multiple radio standards, such as 1 Mbps and 2 Mbps *Bluetooth*[®] low energy, as well as Nordic's proprietary 1 Mbps and 2 Mbps modes of operation.

EasyDMA in combination with an automated packet assembler and packet disassembler, and an automated CRC generator and CRC checker, makes it very easy to configure and use the RADIO. See [RADIO block diagram](#) on page 181 for details.

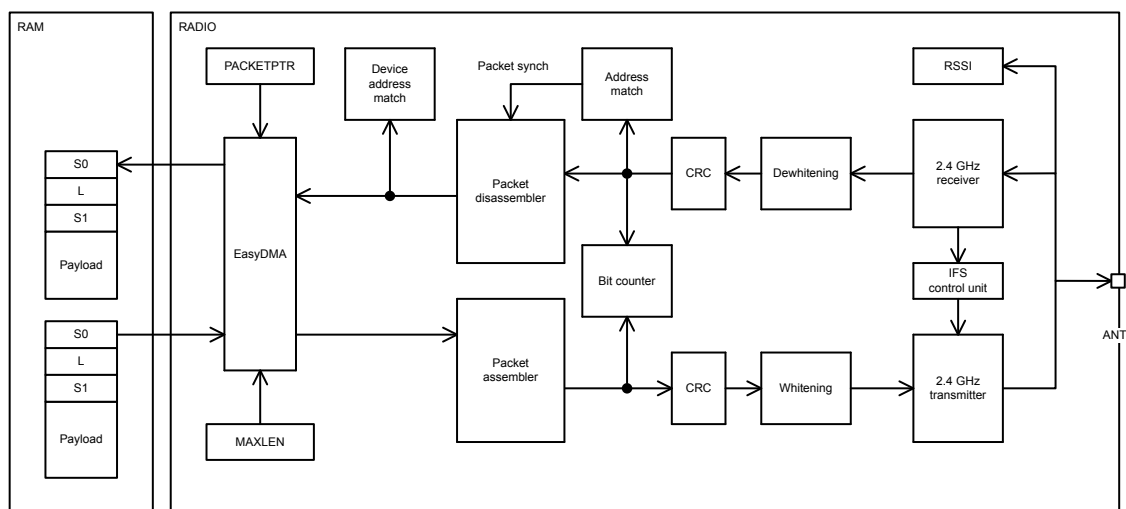

Figure 57: RADIO block diagram

The RADIO includes a device address match unit and an interframe spacing control unit that can be utilized to simplify address white listing and interframe spacing respectively, in *Bluetooth*[®] Smart and similar applications.

The RADIO also includes a received signal strength indicator (RSSI) and a bit counter. The bit counter generates events when a preconfigured number of bits have been sent or received by the RADIO.

6.14.1 EasyDMA

The RADIO peripheral uses EasyDMA for reading of data packets from and writing to RAM, without CPU involvement.

As illustrated in [RADIO block diagram](#) on page 181, the RADIO's EasyDMA utilizes the same [PACKETPTR](#) on page 201 for receiving and transmitting packets, and this pointer can only point to the Data RAM region. See [Memory](#) on page 17 for more information about the different memory regions.

The DISABLED event indicates that the EasyDMA has finished accessing the RAM.

The structure of a radio packet is described in detail in [Packet configuration](#) on page 182. The data that is stored in Data RAM and transported by EasyDMA consists of the following fields:

- S0
- LENGTH
- S1
- PAYLOAD

In addition, a static add-on is sent immediately after the payload.

The size of each of the above fields in the frame is configurable, and the space occupied in RAM depends on these settings. A size of zero is possible for any of the fields, it is up to the user to make sure that the resulting frame complies with the RF protocol chosen. For the field sizes defined in bits, the occupation in RAM will always be rounded up to the next full byte size (for instance 3 bit length will allocate 1 byte in RAM, 9 bit length will allocate 2 bytes, etc.).

The sizes of the fields S0, LENGTH and S1 can be individually configured by the S0LEN, LFLEN and S1LEN fields of the PCNF0 register respectively. The size of the payload is configured through the value in RAM corresponding to the LENGTH field. The size of the static add-on to the payload is configured through the STATLEN field in PCNF1 register.

The MAXLEN field in the PCNF1 register configures the maximum packet payload plus add-on size in number of bytes that can be transmitted or received by the RADIO. This feature can be used to ensure that the RADIO does not overwrite, or read beyond, the RAM assigned to the packet payload. This means that if the packet payload length defined by the PCNF1.STATLEN and the LENGTH field in the packet specify a packet larger than MAXLEN, the payload will be truncated at MAXLEN. The packet's LENGTH field will not be altered when the payload is truncated. The RADIO will calculate CRC as if the packet length is equal to MAXLEN.

Important: Note that MAXLEN includes the size of the payload and the add-on, but excludes the size occupied by the fields S0, LENGTH and S1. This has to be taken into account when allocating RAM.

6.14.2 Packet configuration

RADIO packet contains the following fields: PREAMBLE, ADDRESS, S0, LENGTH, S1, PAYLOAD and CRC.

The content of a RADIO packet is illustrated in [On-air packet layout](#) on page 182. The RADIO sends the different fields in the packet in the order they are illustrated below, from left to right:

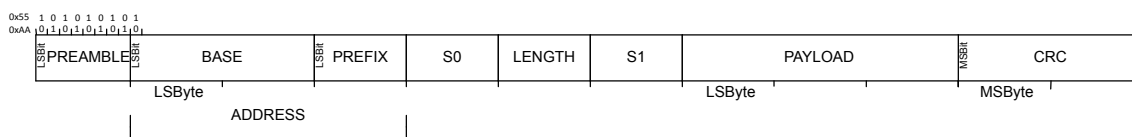

Figure 58: On-air packet layout

PREAMBLE is sent with least significant bit first on-air. For all modes that can be specified in the MODE register, the PREAMBLE is one byte long. If the first bit of the ADDRESS is 0, the PREAMBLE is set to 0xAA. Otherwise the PREAMBLE is set to 0x55.

Not shown in the figure above is the static payload add-on (the length of which is defined in PCNF1.STATLEN, and which is 0 bytes long in a standard BLE packet). The static payload add-on is sent between the PAYLOAD and CRC fields.

The RADIO packets are stored in memory, inside instances of a radio packet data structure as illustrated in [In-RAM representation of radio packet - S0, LENGTH and S1 are optional](#) on page 183. The PREAMBLE, ADDRESS and CRC fields are omitted in this data structure.

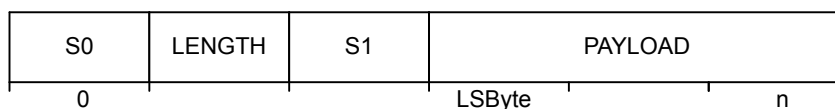

Figure 59: In-RAM representation of radio packet - S0, LENGTH and S1 are optional

The byte ordering on the air is always:

- Least significant byte first for the fields ADDRESS and PAYLOAD. The ADDRESS fields are also always transmitted and received least significant bit first on-air.
- Most significant byte first for the CRC field. The CRC field is also always transmitted and received most significant bit first.

The bit endianness, i.e. the order in which the bits are sent and received, is configured in PCNF1.ENDIAN for the fields S0, LENGTH, S1 and PAYLOAD.

The sizes of the fields S0, LENGTH and S1 can be individually configured in the S0LEN, LFLEN and S1LEN fields of the PCNF0 register respectively. If any of these fields are configured to be less than 8 bit long, the least significant bits of the fields are used, as seen from the RAM representation.

If S0, LENGTH or S1 are specified with zero length, their fields will be omitted in memory. Otherwise each field will be represented as a separate byte, regardless of the number of bits in their on-air counterpart.

6.14.3 Maximum packet length

Independent of the configuration of MAXLEN, the combined length of S0, LENGTH, S1 and PAYLOAD cannot exceed 258 bytes.

6.14.4 Address configuration

The on-air radio ADDRESS field is composed of two parts, the base address field and the address prefix field.

The size of the base address field is configurable via BALEN in PCNF1. The base address is truncated from LSByte if the BALEN is less than 4. See [Definition of logical addresses](#) on page 184.

The on-air addresses are defined in the BASEn and PREFIXn registers, and it is only when writing these registers the user will have to relate to actual on-air addresses. For other radio address registers such as the TXADDRESS, RXADDRESSES and RXMATCH registers, logical radio addresses ranging from 0 to 7 are being used. The relationship between the on-air radio addresses and the logical addresses is described in [Definition of logical addresses](#) on page 184.

Logical address	Base address	Prefix byte
0	BASE0	PREFIX0.AP0
1	BASE1	PREFIX0.AP1
2	BASE1	PREFIX0.AP2
3	BASE1	PREFIX0.AP3
4	BASE1	PREFIX1.AP4
5	BASE1	PREFIX1.AP5
6	BASE1	PREFIX1.AP6
7	BASE1	PREFIX1.AP7

Table 59: Definition of logical addresses

6.14.5 Data whitening

The RADIO is able to do packet whitening and de-whitening.

See WHITEEN in PCNF1 register for how to enable whitening. When enabled, whitening and de-whitening will be handled by the RADIO automatically as packets are sent and received.

The whitening word is generated using polynomial $g(D) = D^7 + D^4 + 1$, which then is XORed with the data packet that is to be whitened, or de-whitened. See the figure below.

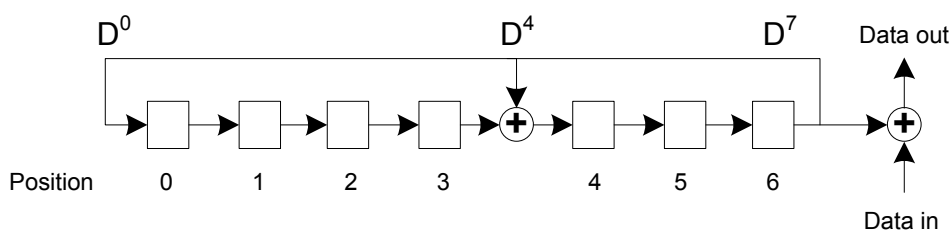

Figure 60: Data whitening and de-whitening

Whitening and de-whitening will be performed over the whole packet (except for the preamble and the address field).

The linear feedback shift register, illustrated in [Data whitening and de-whitening](#) on page 184 can be initialised via the DATAWHITEIV register.

6.14.6 CRC

The CRC generator in the RADIO calculates the CRC over the whole packet excluding the preamble. If desirable, the address field can be excluded from the CRC calculation as well

See CRCCNF register for more information.

The CRC polynomial is configurable as illustrated in [CRC generation of an n bit CRC](#) on page 185 where bit 0 in the CRCPOLY register corresponds to X^0 and bit 1 corresponds to X^1 etc. See CRCPOLY for more information.

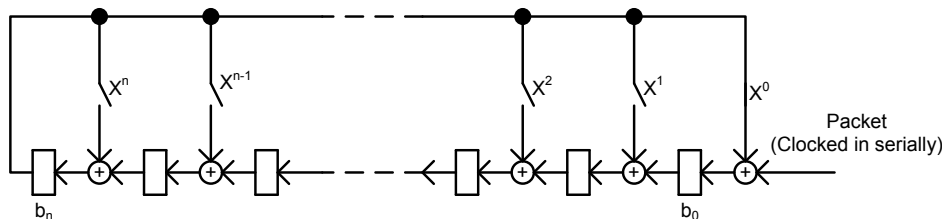

Figure 61: CRC generation of an n bit CRC

As illustrated in [CRC generation of an \$n\$ bit CRC](#) on page 185, the CRC is calculated by feeding the packet serially through the CRC generator. Before the packet is clocked through the CRC generator, the CRC generator's latches b_0 through b_n will be initialized with a predefined value specified in the CRCINIT register. When the whole packet is clocked through the CRC generator, latches b_0 through b_n will hold the resulting CRC. This value will be used by the RADIO during both transmission and reception but it is not available to be read by the CPU at any time. A received CRC can however be read by the CPU via the RXCRC register independent of whether or not it has passed the CRC check.

The length (n) of the CRC is configurable, see CRCCNF for more information.

After the whole packet including the CRC has been received, the RADIO will generate a CRCOK event if no CRC errors were detected, or alternatively generate a CRCERROR event if CRC errors were detected.

The status of the CRC check can be read from the CRCSTATUS register after a packet has been received.

6.14.7 Radio states

The RADIO can enter a number of states.

The RADIO can enter the states described the table below. An overview state diagram for the RADIO is illustrated in [Radio states](#) on page 186. This figure shows how the tasks and events relate to the RADIO's operation. The RADIO does not prevent a task from being triggered from the wrong state. If a task is triggered from the wrong state, for example if the RXEN task is triggered from the RXDISABLE state, this may lead to incorrect behaviour. As illustrated in [Radio states](#) on page 186, the PAYLOAD event is always generated even if the payload is zero.

State	Description
DISABLED	No operations are going on inside the radio and the power consumption is at a minimum
RXRU	The radio is ramping up and preparing for reception
RXIDLE	The radio is ready for reception to start
RX	Reception has been started and the addresses enabled in the RXADDRESSES register are being monitored
TXRU	The radio is ramping up and preparing for transmission
TXIDLE	The radio is ready for transmission to start
TX	The radio is transmitting a packet
RXDISABLE	The radio is disabling the receiver
TXDISABLE	The radio is disabling the transmitter

Table 60: RADIO state diagram

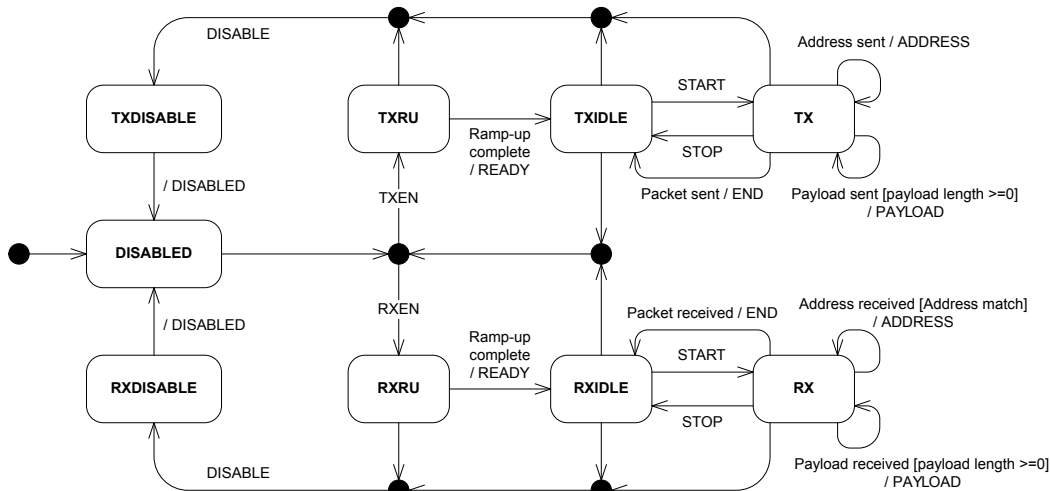

Figure 62: Radio states

6.14.8 Transmit sequence

Before the RADIO is able to transmit a packet, it must first ramp-up in TX mode.

See TXRU in [Radio states](#) on page 186 and [Transmit sequence](#) on page 186. A TXRU ramp-up sequence is initiated when the TXEN task is triggered. After the radio has successfully ramped up it will generate the READY event indicating that a packet transmission can be initiated. A packet transmission is initiated by triggering the START task. As illustrated in [Radio states](#) on page 186 the START task can first be triggered after the RADIO has entered into the TXIDLE state.

[Transmit sequence](#) on page 186 illustrates a single packet transmission where the CPU manually triggers the different tasks needed to control the flow of the RADIO, i.e. no shortcuts are used. If shortcuts are not used, a certain amount of delay caused by CPU execution is expected between READY and START, and between END and DISABLE. As illustrated in [Transmit sequence](#) on page 186 the RADIO will by default transmit '1's between READY and START, and between END and DISABLE. What is transmitted can be programmed through the DTX field in the MODECNF0 register.

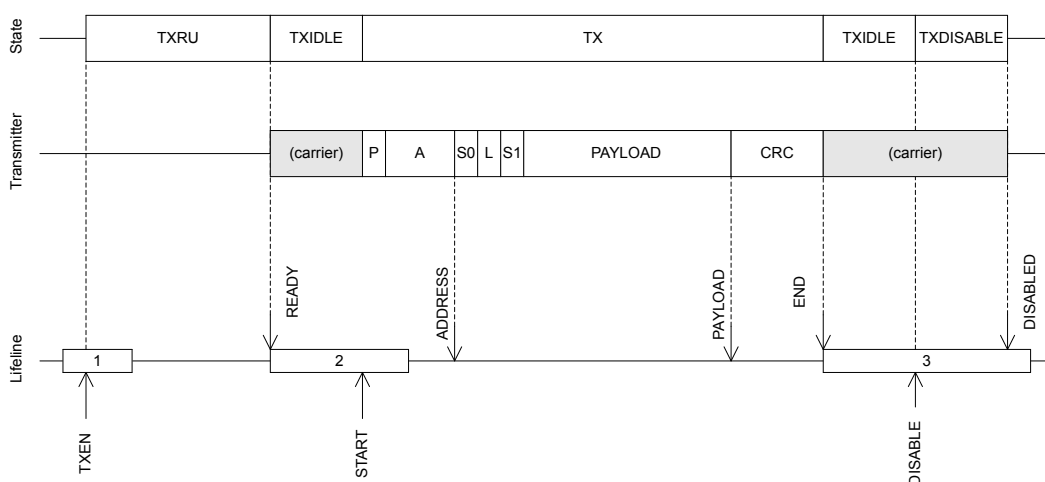

Figure 63: Transmit sequence

A slightly modified version of the transmit sequence from [Transmit sequence](#) on page 186 is illustrated in [Transmit sequence using shortcuts to avoid delays](#) on page 187 where the RADIO is configured to

use shortcuts between READY and START, and between END and DISABLE, which means that no delay is introduced.

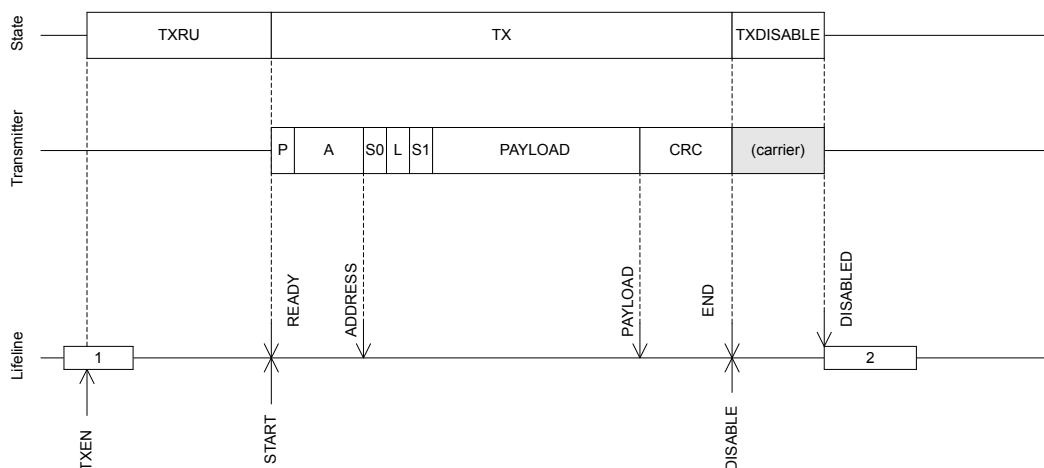

Figure 64: Transmit sequence using shortcuts to avoid delays

The RADIO is able to send multiple packets one after the other without having to disable and re-enable the RADIO between packets, this is illustrated in [Transmission of multiple packets](#) on page 187.

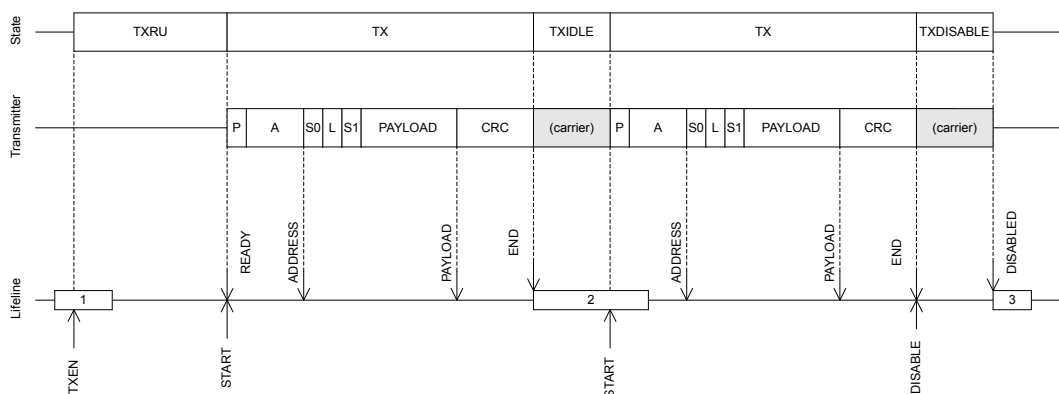

Figure 65: Transmission of multiple packets

6.14.9 Receive sequence

Before the RADIO is able to receive a packet, it must first ramp up in RX mode

See RXRU in [Radio states](#) on page 186 and [Receive sequence](#) on page 188. An RXRU ramp-up sequence is initiated when the RXEN task is triggered. After the radio has successfully ramped up it will generate the READY event indicating that a packet reception can be initiated. A packet reception is initiated by triggering the START task. As illustrated in [Radio states](#) on page 186 the START task can, first be triggered after the RADIO has entered into the RXIDLE state.

[Receive sequence](#) on page 188 illustrates a single packet reception where the CPU manually triggers the different tasks needed to control the flow of the RADIO, i.e. no shortcuts are used. If shortcuts are not used, a certain amount of delay, caused by CPU execution, is expected between READY and START, and between END and DISABLE. As illustrated [Receive sequence](#) on page 188 the RADIO will be listening and possibly receiving undefined data, illustrated with an 'X', from START and until a packet with valid preamble (P) is received.

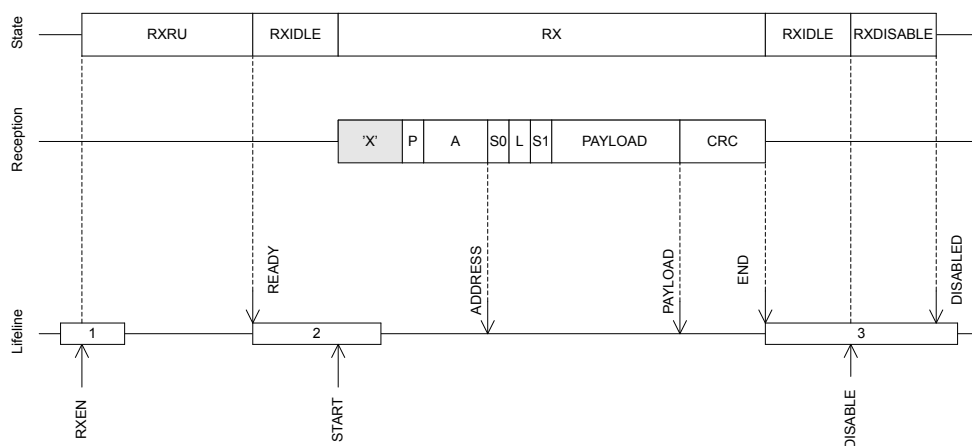

Figure 66: Receive sequence

A slightly modified version of the receive sequence from [Receive sequence](#) on page 188 is illustrated in [Receive sequence using shortcuts to avoid delays](#) on page 188 where the the RADIO is configured to use shortcuts between READY and START, and between END and DISABLE, which means that no delay is introduced.

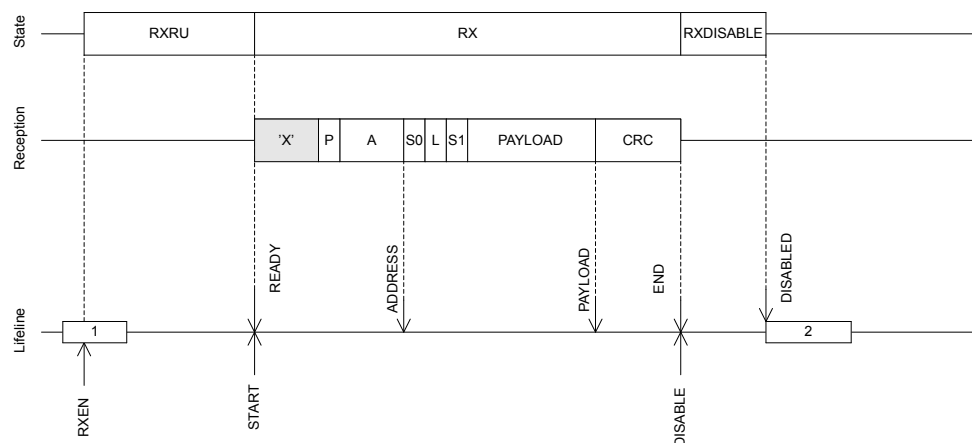

Figure 67: Receive sequence using shortcuts to avoid delays

The RADIO is able to receive multiple packets one after the other without having to disable and re-enable the RADIO between packets, this is illustrated [Reception of multiple packets](#) on page 189.

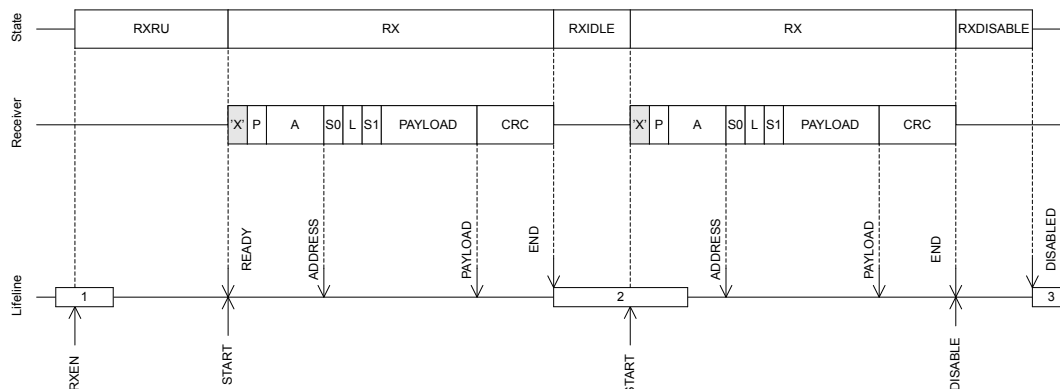

Figure 68: Reception of multiple packets

6.14.10 Received signal strength indicator (RSSI)

A mechanism for measuring the power in the received radio signal is implemented. This feature is called received signal strength indicator (RSSI).

Sampling of the received signal strength is started by using the RSSISTART task. The sample can be read from the RSSISAMPLE register.

The sample period of the RSSI is defined by $RSSI_{PERIOD}$, see the device product specification for details. The RSSI sample will hold the average received signal strength during this sample period.

For the RSSI sample to be valid, the radio has to be enabled in the receive mode (RXEN task) and the reception has to be started (READY event followed by START task).

6.14.11 Interframe spacing

Interframe spacing is the time interval between two consecutive packets.

It is defined as the time (in microseconds) from the end of the last bit of the previous packet received and to the start of the first bit of the subsequent packet that is transmitted. The radio is able to enforce this interval as specified in the TIFS register as long as TIFS is not specified to be shorter than the radio's turn-around time, i.e. the time needed to switch off the receiver, and switch back on the transmitter.

TIFS is only enforced if `END_DISABLE` and `DISABLED_TXEN` or `END_DISABLE` and `DISABLED_RXEN` shortcuts are enabled. TIFS is only qualified for use in BLE_1MBIT mode, and default ramp-up mode. The use of shortcuts and timing is illustrated in [Ramp up and TIFS Timing Details](#) on page 189.

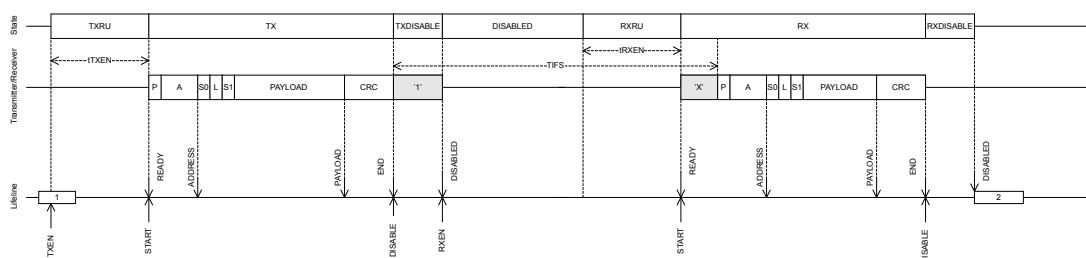

Figure 69: Ramp up and TIFS Timing Details

6.14.12 Device address match

The device address match feature is tailored for address white listing in a *Bluetooth*[®] Smart and similar implementations.

This feature enables on-the-fly device address matching while receiving a packet on air. This feature only works in receive mode and as long as the radio is configured for little endian, see `PCNF1.ENDIAN`.

The device address match unit assumes that the 48 first bits of the payload is the device address and that bit number 6 in S0 is the TxAdd bit. See the *Bluetooth*[®] Core Specification for more information about device addresses, TxAdd and whitelisting.

The radio is able to listen for eight different device addresses at the same time. These addresses are specified in a DAB/DAP register pair, one pair per address, in addition to a TxAdd bit configured in the DACNF register. The DAB register specifies the 32 least significant bits of the device address, while the DAP register specifies the 16 most significant bits of the device address.

Each of the device addresses can be individually included or excluded from the matching mechanism. This is configured in the DACNF register.

6.14.13 Bit counter

Radio implements a simple counter that can be configured to generate an event after a specific number of bits have been transmitted or received.

By using shortcuts, this counter can be started from different events generated by the radio and hence count relative to these.

The bit counter is started by triggering the BCSTART task, and stopped by triggering the BCSTOP task. A BCMATCH event will be generated when the bit counter has counted the number of bits specified in the BCC register. The bit counter will continue to count bits until the DISABLED event is generated or until the BCSTOP task is triggered. The CPU can therefore, after a BCMATCH event, reconfigure the BCC value for new BCMATCH events within the same packet.

The bit counter can only be started after the radio has received the ADDRESS event.

The bit counter will stop and reset on BCSTOP, STOP, END and DISABLE tasks.

The figure below illustrates how the bit counter can be used to generate a BCMATCH event in the beginning of the packet payload, and again generate a second BCMATCH event after sending 2 bytes (16 bits) of the payload.

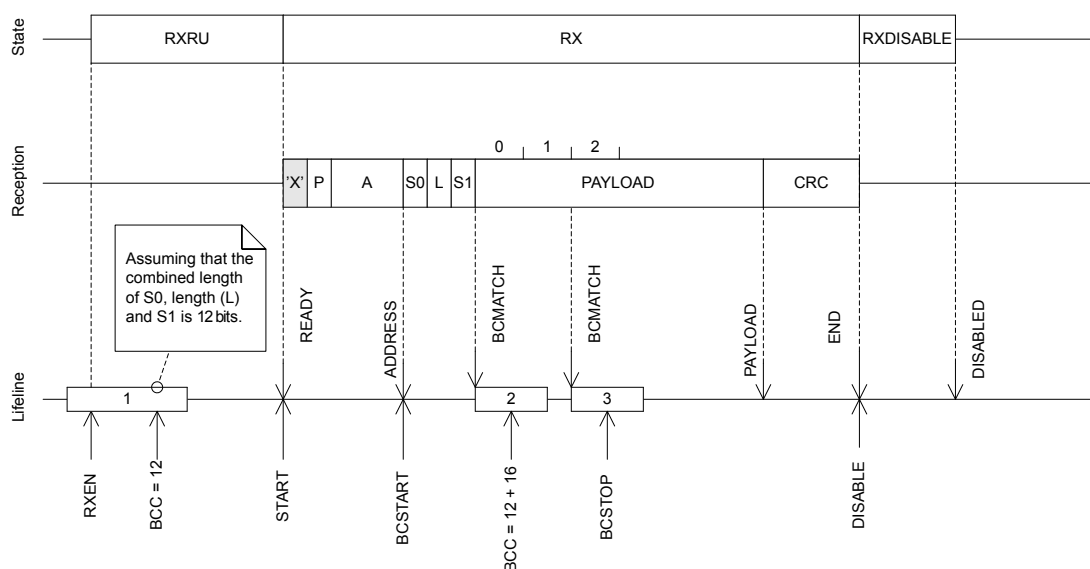

Figure 70: Bit counter example

6.14.14 Registers

Base address	Peripheral	Instance	Description	Configuration
0x40001000	RADIO	RADIO	2.4 GHz radio	

Table 61: Instances

Register	Offset	Description
TASKS_TXEN	0x000	Enable RADIO in TX mode
TASKS_RXEN	0x004	Enable RADIO in RX mode
TASKS_START	0x008	Start RADIO
TASKS_STOP	0x00C	Stop RADIO
TASKS_DISABLE	0x010	Disable RADIO
TASKS_RSSISTART	0x014	Start the RSSI and take one single sample of the receive signal strength.
TASKS_RSSISTOP	0x018	Stop the RSSI measurement
TASKS_BCSTART	0x01C	Start the bit counter
TASKS_BCSTOP	0x020	Stop the bit counter
EVENTS_READY	0x100	RADIO has ramped up and is ready to be started
EVENTS_ADDRESS	0x104	Address sent or received
EVENTS_PAYLOAD	0x108	Packet payload sent or received
EVENTS_END	0x10C	Packet sent or received
EVENTS_DISABLED	0x110	RADIO has been disabled
EVENTS_DEVMATCH	0x114	A device address match occurred on the last received packet
EVENTS_DEVMISS	0x118	No device address match occurred on the last received packet
EVENTS_RSSIEND	0x11C	Sampling of receive signal strength complete.
EVENTS_BCMATCH	0x128	Bit counter reached bit count value.
EVENTS_CRCOK	0x130	Packet received with CRC ok
EVENTS_CRCERROR	0x134	Packet received with CRC error
SHORTS	0x200	Shortcuts between local events and tasks
INTENSET	0x304	Enable interrupt
INTENCLR	0x308	Disable interrupt
CRCSTATUS	0x400	CRC status
RXMATCH	0x408	Received address
RXCRC	0x40C	CRC field of previously received packet
DAI	0x410	Device address match index
PACKETPTR	0x504	Packet pointer
FREQUENCY	0x508	Frequency
TXPOWER	0x50C	Output power
MODE	0x510	Data rate and modulation
PCNF0	0x514	Packet configuration register 0
PCNF1	0x518	Packet configuration register 1
BASE0	0x51C	Base address 0
BASE1	0x520	Base address 1
PREFIX0	0x524	Prefixes bytes for logical addresses 0-3
PREFIX1	0x528	Prefixes bytes for logical addresses 4-7
TXADDRESS	0x52C	Transmit address select
RXADDRESSES	0x530	Receive address select
CRCCNF	0x534	CRC configuration
CRCPOLY	0x538	CRC polynomial
CRCINIT	0x53C	CRC initial value
UNUSED0	0x540	Reserved
TIFS	0x544	Inter Frame Spacing in us
RSSISAMPLE	0x548	RSSI sample

Register	Offset	Description
STATE	0x550	Current radio state
DATAWHITEIV	0x554	Data whitening initial value
BCC	0x560	Bit counter compare
DAB[0]	0x600	Device address base segment 0
DAB[1]	0x604	Device address base segment 1
DAB[2]	0x608	Device address base segment 2
DAB[3]	0x60C	Device address base segment 3
DAB[4]	0x610	Device address base segment 4
DAB[5]	0x614	Device address base segment 5
DAB[6]	0x618	Device address base segment 6
DAB[7]	0x61C	Device address base segment 7
DAP[0]	0x620	Device address prefix 0
DAP[1]	0x624	Device address prefix 1
DAP[2]	0x628	Device address prefix 2
DAP[3]	0x62C	Device address prefix 3
DAP[4]	0x630	Device address prefix 4
DAP[5]	0x634	Device address prefix 5
DAP[6]	0x638	Device address prefix 6
DAP[7]	0x63C	Device address prefix 7
DACNF	0x640	Device address match configuration
MODECNFO	0x650	Radio mode configuration register 0
POWER	0xFFC	Peripheral power control

Table 62: Register overview

6.14.14.1 TASKS_TXEN

Address offset: 0x000

Enable RADIO in TX mode

Bit number	31 30 29 28 27 26 25 24 23 22 21 20 19 18 17 16 15 14 13 12 11 10 9 8 7 6 5 4 3 2 1 0																														
ID	A																														
Reset 0x00000000	0 0																														
ID	Acce Field	Value ID	Value	Description																											
A	W TASKS_TXEN			Enable RADIO in TX mode																											
		Trigger	1	Trigger task																											

6.14.14.2 TASKS_RXEN

Address offset: 0x004

Enable RADIO in RX mode

Bit number	31 30 29 28 27 26 25 24 23 22 21 20 19 18 17 16 15 14 13 12 11 10 9 8 7 6 5 4 3 2 1 0																														
ID	A																														
Reset 0x00000000	0 0																														
ID	Acce Field	Value ID	Value	Description																											
A	W TASKS_RXEN			Enable RADIO in RX mode																											
		Trigger	1	Trigger task																											

6.14.14.3 TASKS_START

Address offset: 0x008

Start RADIO

Bit number	31 30 29 28 27 26 25 24 23 22 21 20 19 18 17 16 15 14 13 12 11 10 9 8 7 6 5 4 3 2 1 0																														
ID	A																														
Reset 0x00000000	0 0																														
ID	Acce Field	Value ID	Value	Description																											
A	W TASKS_START			Start RADIO																											
		Trigger	1	Trigger task																											

6.14.14.4 TASKS_STOP

Address offset: 0x00C

Stop RADIO

Bit number	31 30 29 28 27 26 25 24 23 22 21 20 19 18 17 16 15 14 13 12 11 10 9 8 7 6 5 4 3 2 1 0																														
ID	A																														
Reset 0x00000000	0 0																														
ID	Acce Field	Value ID	Value	Description																											
A	W TASKS_STOP			Stop RADIO																											
		Trigger	1	Trigger task																											

6.14.14.5 TASKS_DISABLE

Address offset: 0x010

Disable RADIO

Bit number	31 30 29 28 27 26 25 24 23 22 21 20 19 18 17 16 15 14 13 12 11 10 9 8 7 6 5 4 3 2 1 0																														
ID	A																														
Reset 0x00000000	0 0																														
ID	Acce Field	Value ID	Value	Description																											
A	W TASKS_DISABLE			Disable RADIO																											
		Trigger	1	Trigger task																											

6.14.14.6 TASKS_RSSISTART

Address offset: 0x014

Start the RSSI and take one single sample of the receive signal strength.

Bit number	31 30 29 28 27 26 25 24 23 22 21 20 19 18 17 16 15 14 13 12 11 10 9 8 7 6 5 4 3 2 1 0																														
ID	A																														
Reset 0x00000000	0 0																														
ID	Acce Field	Value ID	Value	Description																											
A	W TASKS_RSSISTART			Start the RSSI and take one single sample of the receive signal strength.																											
		Trigger	1	Trigger task																											

6.14.14.7 TASKS_RSSISTOP

Address offset: 0x018

Stop the RSSI measurement

Bit number	31	30	29	28	27	26	25	24	23	22	21	20	19	18	17	16	15	14	13	12	11	10	9	8	7	6	5	4	3	2	1	0
ID																																A
Reset 0x00000000	0 0																															
ID	Acce Field	Value ID	Value	Description																												
A	W TASKS_RSSISTOP	Trigger	1	Stop the RSSI measurement Trigger task																												

6.14.14.8 TASKS_BCSTART

Address offset: 0x01C

Start the bit counter

Bit number	31	30	29	28	27	26	25	24	23	22	21	20	19	18	17	16	15	14	13	12	11	10	9	8	7	6	5	4	3	2	1	0
ID																																A
Reset 0x00000000	0 0																															
ID	Acce Field	Value ID	Value	Description																												
A	W TASKS_BCSTART	Trigger	1	Start the bit counter Trigger task																												

6.14.14.9 TASKS_BCSTOP

Address offset: 0x020

Stop the bit counter

Bit number	31	30	29	28	27	26	25	24	23	22	21	20	19	18	17	16	15	14	13	12	11	10	9	8	7	6	5	4	3	2	1	0
ID																																A
Reset 0x00000000	0 0																															
ID	Acce Field	Value ID	Value	Description																												
A	W TASKS_BCSTOP	Trigger	1	Stop the bit counter Trigger task																												

6.14.14.10 EVENTS_READY

Address offset: 0x100

RADIO has ramped up and is ready to be started

Bit number	31	30	29	28	27	26	25	24	23	22	21	20	19	18	17	16	15	14	13	12	11	10	9	8	7	6	5	4	3	2	1	0
ID																																A
Reset 0x00000000	0 0																															
ID	Acce Field	Value ID	Value	Description																												
A	RW EVENTS_READY	NotGenerated	0	RADIO has ramped up and is ready to be started Event not generated																												
		Generated	1	Event generated																												

6.14.14.11 EVENTS_ADDRESS

Address offset: 0x104

Address sent or received

Bit number	31	30	29	28	27	26	25	24	23	22	21	20	19	18	17	16	15	14	13	12	11	10	9	8	7	6	5	4	3	2	1	0	
ID																																A	
Reset	0x00000000																																
0	0	0	0	0	0	0	0	0	0	0	0	0	0	0	0	0	0	0	0	0	0	0	0	0	0	0	0	0	0	0	0	0	0
ID	Acce Field	Value ID	Value	Description																													
A	RW	EVENTS_ADDRESS		Address sent or received																													
		NotGenerated	0	Event not generated																													
		Generated	1	Event generated																													

6.14.14.12 EVENTS_PAYLOAD

Address offset: 0x108

Packet payload sent or received

Bit number	31	30	29	28	27	26	25	24	23	22	21	20	19	18	17	16	15	14	13	12	11	10	9	8	7	6	5	4	3	2	1	0
ID																																A
Reset	0x00000000																															
0	0	0	0	0	0	0	0	0	0	0	0	0	0	0	0	0	0	0	0	0	0	0	0	0	0	0	0	0	0	0	0	0
ID	Acce Field	Value ID	Value	Description																												
A	RW	EVENTS_PAYLOAD		Packet payload sent or received																												
		NotGenerated	0	Event not generated																												
		Generated	1	Event generated																												

6.14.14.13 EVENTS_END

Address offset: 0x10C

Packet sent or received

Bit number	31	30	29	28	27	26	25	24	23	22	21	20	19	18	17	16	15	14	13	12	11	10	9	8	7	6	5	4	3	2	1	0
ID																																A
Reset	0x00000000																															
0	0	0	0	0	0	0	0	0	0	0	0	0	0	0	0	0	0	0	0	0	0	0	0	0	0	0	0	0	0	0	0	0
ID	Acce Field	Value ID	Value	Description																												
A	RW	EVENTS_END		Packet sent or received																												
		NotGenerated	0	Event not generated																												
		Generated	1	Event generated																												

6.14.14.14 EVENTS_DISABLED

Address offset: 0x110

RADIO has been disabled

Bit number	31	30	29	28	27	26	25	24	23	22	21	20	19	18	17	16	15	14	13	12	11	10	9	8	7	6	5	4	3	2	1	0
ID																																A
Reset	0x00000000																															
0	0	0	0	0	0	0	0	0	0	0	0	0	0	0	0	0	0	0	0	0	0	0	0	0	0	0	0	0	0	0	0	0
ID	Acce Field	Value ID	Value	Description																												
A	RW	EVENTS_DISABLED		RADIO has been disabled																												
		NotGenerated	0	Event not generated																												
		Generated	1	Event generated																												

6.14.14.15 EVENTS_DEVMATCH

Address offset: 0x114

A device address match occurred on the last received packet

Bit number	31	30	29	28	27	26	25	24	23	22	21	20	19	18	17	16	15	14	13	12	11	10	9	8	7	6	5	4	3	2	1	0
ID																																A
Reset	0x00000000																															
Reset	0	0	0	0	0	0	0	0	0	0	0	0	0	0	0	0	0	0	0	0	0	0	0	0	0	0	0	0	0	0	0	0
ID	Acce Field	Value ID	Value	Description																												
A	RW	EVENTS_DEVMATCH		A device address match occurred on the last received packet																												
		NotGenerated	0	Event not generated																												
		Generated	1	Event generated																												

6.14.14.16 EVENTS_DEVMISS

Address offset: 0x118

No device address match occurred on the last received packet

Bit number	31	30	29	28	27	26	25	24	23	22	21	20	19	18	17	16	15	14	13	12	11	10	9	8	7	6	5	4	3	2	1	0
ID																																A
Reset	0x00000000																															
Reset	0	0	0	0	0	0	0	0	0	0	0	0	0	0	0	0	0	0	0	0	0	0	0	0	0	0	0	0	0	0	0	
ID	Acce Field	Value ID	Value	Description																												
A	RW	EVENTS_DEVMISS		No device address match occurred on the last received packet																												
		NotGenerated	0	Event not generated																												
		Generated	1	Event generated																												

6.14.14.17 EVENTS_RSSIEND

Address offset: 0x11C

Sampling of receive signal strength complete.

A new RSSI sample is ready for readout from the RADIO.RSSISAMPLE register

Bit number	31	30	29	28	27	26	25	24	23	22	21	20	19	18	17	16	15	14	13	12	11	10	9	8	7	6	5	4	3	2	1	0
ID																																A
Reset	0x00000000																															
Reset	0	0	0	0	0	0	0	0	0	0	0	0	0	0	0	0	0	0	0	0	0	0	0	0	0	0	0	0	0	0	0	
ID	Acce Field	Value ID	Value	Description																												
A	RW	EVENTS_RSSIEND		Sampling of receive signal strength complete.																												
				A new RSSI sample is ready for readout from the RADIO.RSSISAMPLE register																												
		NotGenerated	0	Event not generated																												
		Generated	1	Event generated																												

6.14.14.18 EVENTS_BCMATCH

Address offset: 0x128

Bit counter reached bit count value.

Bit counter value is specified in the RADIO.BCC register

Bit number	31 30 29 28 27 26 25 24 23 22 21 20 19 18 17 16 15 14 13 12 11 10 9 8 7 6 5 4 3 2 1 0																														
ID	A																														
Reset 0x00000000	0 0																														
ID	Acce Field	Value ID	Value	Description																											
A	RW EVENTS_BCMATCH			Bit counter reached bit count value.																											
				Bit counter value is specified in the RADIO.BCC register																											
		NotGenerated	0	Event not generated																											
		Generated	1	Event generated																											

6.14.14.19 EVENTS_CRCOK

Address offset: 0x130

Packet received with CRC ok

Bit number	31 30 29 28 27 26 25 24 23 22 21 20 19 18 17 16 15 14 13 12 11 10 9 8 7 6 5 4 3 2 1 0																														
ID	A																														
Reset 0x00000000	0 0																														
ID	Acce Field	Value ID	Value	Description																											
A	RW EVENTS_CRCOK			Packet received with CRC ok																											
		NotGenerated	0	Event not generated																											
		Generated	1	Event generated																											

6.14.14.20 EVENTS_CRCERROR

Address offset: 0x134

Packet received with CRC error

Bit number	31 30 29 28 27 26 25 24 23 22 21 20 19 18 17 16 15 14 13 12 11 10 9 8 7 6 5 4 3 2 1 0																														
ID	A																														
Reset 0x00000000	0 0																														
ID	Acce Field	Value ID	Value	Description																											
A	RW EVENTS_CRCERROR			Packet received with CRC error																											
		NotGenerated	0	Event not generated																											
		Generated	1	Event generated																											

6.14.14.21 SHORTS

Address offset: 0x200

Shortcuts between local events and tasks

Bit number	31 30 29 28 27 26 25 24 23 22 21 20 19 18 17 16 15 14 13 12 11 10 9 8 7 6 5 4 3 2 1 0																																							
ID																									H		G		F		E		D		C		B		A	
Reset 0x00000000	0 0																																							
ID	Acce Field	Value ID	Value	Description																																				
A	RW READY_START			Shortcut between event READY and task START																																				
		Disabled	0	Disable shortcut																																				
		Enabled	1	Enable shortcut																																				
B	RW END_DISABLE			Shortcut between event END and task DISABLE																																				
		Disabled	0	Disable shortcut																																				
		Enabled	1	Enable shortcut																																				
C	RW DISABLED_TXEN			Shortcut between event DISABLED and task TXEN																																				

Bit number	31 30 29 28 27 26 25 24 23 22 21 20 19 18 17 16 15 14 13 12 11 10 9 8 7 6 5 4 3 2 1 0																																					
ID																															H	G	F	E	D	C	B	A
Reset 0x00000000	0 0																																					
ID	Acce	Field	Value ID	Value	Description																																	
			Disabled	0	Disable shortcut																																	
			Enabled	1	Enable shortcut																																	
D	RW	DISABLED_RXEN			Shortcut between event DISABLED and task RXEN																																	
			Disabled	0	Disable shortcut																																	
			Enabled	1	Enable shortcut																																	
E	RW	ADDRESS_RSSISTART			Shortcut between event ADDRESS and task RSSISTART																																	
			Disabled	0	Disable shortcut																																	
			Enabled	1	Enable shortcut																																	
F	RW	END_START			Shortcut between event END and task START																																	
			Disabled	0	Disable shortcut																																	
			Enabled	1	Enable shortcut																																	
G	RW	ADDRESS_BCSTART			Shortcut between event ADDRESS and task BCSTART																																	
			Disabled	0	Disable shortcut																																	
			Enabled	1	Enable shortcut																																	
H	RW	DISABLED_RSSISTOP			Shortcut between event DISABLED and task RSSISTOP																																	
			Disabled	0	Disable shortcut																																	
			Enabled	1	Enable shortcut																																	

6.14.14.22 INTENSET

Address offset: 0x304

Enable interrupt

Bit number	31 30 29 28 27 26 25 24 23 22 21 20 19 18 17 16 15 14 13 12 11 10 9 8 7 6 5 4 3 2 1 0																																								
ID																															K	J	I	H	G	F	E	D	C	B	A
Reset 0x00000000	0 0																																								
ID	Acce	Field	Value ID	Value	Description																																				
A	RW	READY			Write '1' to enable interrupt for event READY																																				
			Set	1	Enable																																				
			Disabled	0	Read: Disabled																																				
			Enabled	1	Read: Enabled																																				
B	RW	ADDRESS			Write '1' to enable interrupt for event ADDRESS																																				
			Set	1	Enable																																				
			Disabled	0	Read: Disabled																																				
			Enabled	1	Read: Enabled																																				
C	RW	PAYLOAD			Write '1' to enable interrupt for event PAYLOAD																																				
			Set	1	Enable																																				
			Disabled	0	Read: Disabled																																				
			Enabled	1	Read: Enabled																																				
D	RW	END			Write '1' to enable interrupt for event END																																				
			Set	1	Enable																																				
			Disabled	0	Read: Disabled																																				
			Enabled	1	Read: Enabled																																				
E	RW	DISABLED			Write '1' to enable interrupt for event DISABLED																																				
			Set	1	Enable																																				
			Disabled	0	Read: Disabled																																				
			Enabled	1	Read: Enabled																																				
F	RW	DEVMATCH			Write '1' to enable interrupt for event DEVMATCH																																				
			Set	1	Enable																																				

Bit number	31 30 29 28 27 26 25 24 23 22 21 20 19 18 17 16 15 14 13 12 11 10 9 8 7 6 5 4 3 2 1 0																																										
ID																													K	J	I	H					G	F	E	D	C	B	A
Reset 0x00000000	0 0																																										
ID	Acce Field	Value ID	Value	Description																																							
		Disabled	0	Read: Disabled																																							
		Enabled	1	Read: Enabled																																							
G	RW DEVMISS			Write '1' to enable interrupt for event DEVMISS																																							
		Set	1	Enable																																							
		Disabled	0	Read: Disabled																																							
		Enabled	1	Read: Enabled																																							
H	RW RSSIEND			Write '1' to enable interrupt for event RSSIEND																																							
				A new RSSI sample is ready for readout from the RADIO.RSSISAMPLE register																																							
		Set	1	Enable																																							
		Disabled	0	Read: Disabled																																							
		Enabled	1	Read: Enabled																																							
I	RW BCMATCH			Write '1' to enable interrupt for event BCMATCH																																							
				Bit counter value is specified in the RADIO.BCC register																																							
		Set	1	Enable																																							
		Disabled	0	Read: Disabled																																							
		Enabled	1	Read: Enabled																																							
J	RW CRCOK			Write '1' to enable interrupt for event CRCOK																																							
		Set	1	Enable																																							
		Disabled	0	Read: Disabled																																							
		Enabled	1	Read: Enabled																																							
K	RW CRCERROR			Write '1' to enable interrupt for event CRCERROR																																							
		Set	1	Enable																																							
		Disabled	0	Read: Disabled																																							
		Enabled	1	Read: Enabled																																							

6.14.14.23 INTENCLR

Address offset: 0x308

Disable interrupt

Bit number	31 30 29 28 27 26 25 24 23 22 21 20 19 18 17 16 15 14 13 12 11 10 9 8 7 6 5 4 3 2 1 0																																										
ID																													K	J	I	H					G	F	E	D	C	B	A
Reset 0x00000000	0 0																																										
ID	Acce Field	Value ID	Value	Description																																							
A	RW READY			Write '1' to disable interrupt for event READY																																							
		Clear	1	Disable																																							
		Disabled	0	Read: Disabled																																							
		Enabled	1	Read: Enabled																																							
B	RW ADDRESS			Write '1' to disable interrupt for event ADDRESS																																							
		Clear	1	Disable																																							
		Disabled	0	Read: Disabled																																							
		Enabled	1	Read: Enabled																																							
C	RW PAYLOAD			Write '1' to disable interrupt for event PAYLOAD																																							
		Clear	1	Disable																																							
		Disabled	0	Read: Disabled																																							
		Enabled	1	Read: Enabled																																							
D	RW END			Write '1' to disable interrupt for event END																																							
		Clear	1	Disable																																							

Bit number	31 30 29 28 27 26 25 24 23 22 21 20 19 18 17 16 15 14 13 12 11 10 9 8 7 6 5 4 3 2 1 0																														
ID	K J I H G F E D C B A																														
Reset 0x00000000	0 0																														
ID	Acce Field	Value ID	Value	Description																											
		Disabled	0	Read: Disabled																											
		Enabled	1	Read: Enabled																											
E	RW DISABLED			Write '1' to disable interrupt for event DISABLED																											
		Clear	1	Disable																											
		Disabled	0	Read: Disabled																											
		Enabled	1	Read: Enabled																											
F	RW DEVMATCH			Write '1' to disable interrupt for event DEVMATCH																											
		Clear	1	Disable																											
		Disabled	0	Read: Disabled																											
		Enabled	1	Read: Enabled																											
G	RW DEVMISS			Write '1' to disable interrupt for event DEVMISS																											
		Clear	1	Disable																											
		Disabled	0	Read: Disabled																											
		Enabled	1	Read: Enabled																											
H	RW RSSIEND			Write '1' to disable interrupt for event RSSIEND																											
				A new RSSI sample is ready for readout from the RADIO.RSSISAMPLE register																											
		Clear	1	Disable																											
		Disabled	0	Read: Disabled																											
		Enabled	1	Read: Enabled																											
I	RW BCMATCH			Write '1' to disable interrupt for event BCMATCH																											
				Bit counter value is specified in the RADIO.BCC register																											
		Clear	1	Disable																											
		Disabled	0	Read: Disabled																											
		Enabled	1	Read: Enabled																											
J	RW CRCOK			Write '1' to disable interrupt for event CRCOK																											
		Clear	1	Disable																											
		Disabled	0	Read: Disabled																											
		Enabled	1	Read: Enabled																											
K	RW CRCERROR			Write '1' to disable interrupt for event CRCERROR																											
		Clear	1	Disable																											
		Disabled	0	Read: Disabled																											
		Enabled	1	Read: Enabled																											

6.14.14.24 CRCSTATUS

Address offset: 0x400

CRC status

Bit number	31 30 29 28 27 26 25 24 23 22 21 20 19 18 17 16 15 14 13 12 11 10 9 8 7 6 5 4 3 2 1 0																														
ID	A																														
Reset 0x00000000	0 0																														
ID	Acce Field	Value ID	Value	Description																											
A	R	CRCSTATUS		CRC status of packet received																											
		CRCError	0	Packet received with CRC error																											
		CRCOK	1	Packet received with CRC ok																											

6.14.14.25 RXMATCH

Address offset: 0x408

Received address

Bit number	31	30	29	28	27	26	25	24	23	22	21	20	19	18	17	16	15	14	13	12	11	10	9	8	7	6	5	4	3	2	1	0
ID																											A	A	A			
Reset 0x00000000	0 0																															
ID	Acce Field	Value ID	Value	Description																												
A	R	RXMATCH		Received address																												
				Logical address of which previous packet was received																												

6.14.14.26 RXCRC

Address offset: 0x40C

CRC field of previously received packet

Bit number	31	30	29	28	27	26	25	24	23	22	21	20	19	18	17	16	15	14	13	12	11	10	9	8	7	6	5	4	3	2	1	0																							
ID																											A	A	A	A	A	A	A	A	A	A	A	A	A	A	A	A	A	A	A	A	A	A	A	A	A	A	A	A	A
Reset 0x00000000	0 0																																																						
ID	Acce Field	Value ID	Value	Description																																																			
A	R	RXCRC		CRC field of previously received packet																																																			
				CRC field of previously received packet																																																			

6.14.14.27 DAI

Address offset: 0x410

Device address match index

Bit number	31	30	29	28	27	26	25	24	23	22	21	20	19	18	17	16	15	14	13	12	11	10	9	8	7	6	5	4	3	2	1	0
ID																											A	A	A			
Reset 0x00000000	0 0																															
ID	Acce Field	Value ID	Value	Description																												
A	R	DAI		Device address match index																												
				Index (n) of device address, see DAB[n] and DAP[n], that got an address match.																												

6.14.14.28 PACKETPTR

Address offset: 0x504

Packet pointer

Bit number	31	30	29	28	27	26	25	24	23	22	21	20	19	18	17	16	15	14	13	12	11	10	9	8	7	6	5	4	3	2	1	0
ID	A	A	A	A	A	A	A	A	A	A	A	A	A	A	A	A	A	A	A	A	A	A	A	A	A	A	A	A	A	A	A	A
Reset	0x00000000																															
Reset	0	0	0	0	0	0	0	0	0	0	0	0	0	0	0	0	0	0	0	0	0	0	0	0	0	0	0	0	0	0	0	0

ID	Acce Field	Value ID	Value	Description
A	RW	PACKETPTR		<p>Packet pointer</p> <p>Packet address to be used for the next transmission or reception. When transmitting, the packet pointed to by this address will be transmitted and when receiving, the received packet will be written to this address. This address is a byte aligned ram address.</p>

6.14.14.29 FREQUENCY

Address offset: 0x508

Frequency

Bit number	31	30	29	28	27	26	25	24	23	22	21	20	19	18	17	16	15	14	13	12	11	10	9	8	7	6	5	4	3	2	1	0																
ID																								B	A	A	A	A	A	A	A																	
Reset	0x00000002																																															
Reset	0	0	0	0	0	0	0	0	0	0	0	0	0	0	0	0	0	0	0	0	0	0	0	0	0	0	0	0	0	0	0	1	0															

ID	Acce Field	Value ID	Value	Description
A	RW	FREQUENCY	[0..100]	<p>Radio channel frequency</p> <p>Frequency = 2400 + FREQUENCY (MHz).</p>
B	RW	MAP		<p>Channel map selection.</p> <p>Channel map between 2400 MHz .. 2500 MHz</p> <p>Frequency = 2400 + FREQUENCY (MHz)</p> <p>Channel map between 2360 MHz .. 2460 MHz</p> <p>Frequency = 2360 + FREQUENCY (MHz)</p>
		Default	0	
		Low	1	

6.14.14.30 TXPOWER

Address offset: 0x50C

Output power

Bit number	31	30	29	28	27	26	25	24	23	22	21	20	19	18	17	16	15	14	13	12	11	10	9	8	7	6	5	4	3	2	1	0															
ID																								A	A	A	A	A	A	A																	
Reset	0x00000000																																														
Reset	0	0	0	0	0	0	0	0	0	0	0	0	0	0	0	0	0	0	0	0	0	0	0	0	0	0	0	0	0	0	0	0															

ID	Acce Field	Value ID	Value	Description
A	RW	TXPOWER		<p>RADIO output power.</p> <p>Output power in number of dBm, i.e. if the value -20 is specified the output power will be set to -20dBm.</p>
		Pos4dBm	0x04	+4 dBm
		Pos3dBm	0x03	+3 dBm
		0dBm	0x00	0 dBm
		Neg4dBm	0xFC	-4 dBm
		Neg8dBm	0xF8	-8 dBm
		Neg12dBm	0xF4	-12 dBm
		Neg16dBm	0xF0	-16 dBm
		Neg20dBm	0xEC	-20 dBm
		Neg30dBm	0xE2	-40 dBm
		Neg40dBm	0xD8	-40 dBm

Deprecated

6.14.14.31 MODE

Address offset: 0x510

Data rate and modulation

Bit number	31 30 29 28 27 26 25 24 23 22 21 20 19 18 17 16 15 14 13 12 11 10 9 8 7 6 5 4 3 2 1 0																															
ID																													A	A	A	A
Reset 0x00000000	0 0																															
ID	Acce Field	Value ID	Value	Description																												
A	RW	MODE		Radio data rate and modulation setting. The radio supports Frequency-shift Keying (FSK) modulation.																												
		Nrf_1Mbit	0	1 Mbit/s Nordic proprietary radio mode																												
		Nrf_2Mbit	1	2 Mbit/s Nordic proprietary radio mode																												
		Ble_1Mbit	3	1 Mbit/s Bluetooth Low Energy																												
		Ble_2Mbit	4	2 Mbit/s Bluetooth Low Energy																												

6.14.14.32 PCNF0

Address offset: 0x514

Packet configuration register 0

Bit number	31 30 29 28 27 26 25 24 23 22 21 20 19 18 17 16 15 14 13 12 11 10 9 8 7 6 5 4 3 2 1 0																																								
ID																													G	F	E	E	E	C	A				A	A	A
Reset 0x00000000	0 0																																								
ID	Acce Field	Value ID	Value	Description																																					
A	RW	LFLLEN		Length on air of LENGTH field in number of bits.																																					
C	RW	SOLEN		Length on air of S0 field in number of bytes.																																					
E	RW	S1LEN		Length on air of S1 field in number of bits.																																					
F	RW	S1INCL		Include or exclude S1 field in RAM																																					
		Automatic	0	Include S1 field in RAM only if S1LEN > 0																																					
		Include	1	Always include S1 field in RAM independent of S1LEN																																					
G	RW	PLEN		Length of preamble on air. Decision point: TASKS_START task																																					
		8bit	0	8-bit preamble																																					
		16bit	1	16-bit preamble																																					

6.14.14.33 PCNF1

Address offset: 0x518

Packet configuration register 1

Bit number	31 30 29 28 27 26 25 24 23 22 21 20 19 18 17 16 15 14 13 12 11 10 9 8 7 6 5 4 3 2 1 0																														
ID	E D C C C B B B B B B A A A A A A A																														
Reset 0x00000000	0 0																														
ID	Acce Field	Value ID	Value	Description																											
A	RW	MAXLEN	[0..255]	Maximum length of packet payload. If the packet payload is larger than MAXLEN, the radio will truncate the payload to MAXLEN.																											
B	RW	STATLEN	[0..255]	Static length in number of bytes The static length parameter is added to the total length of the payload when sending and receiving packets, e.g. if the static length is set to N the radio will receive or send N bytes more than what is defined in the LENGTH field of the packet.																											
C	RW	BALEN	[2..4]	Base address length in number of bytes The address field is composed of the base address and the one byte long address prefix, e.g. set BALEN=2 to get a total address of 3 bytes.																											
D	RW	ENDIAN		On air endianness of packet, this applies to the S0, LENGTH, S1 and the PAYLOAD fields.																											
		Little	0	Least Significant bit on air first																											
		Big	1	Most significant bit on air first																											
E	RW	WHITEEN		Enable or disable packet whitening																											
		Disabled	0	Disable																											
		Enabled	1	Enable																											

6.14.14.34 BASE0

Address offset: 0x51C

Base address 0

Bit number	31 30 29 28 27 26 25 24 23 22 21 20 19 18 17 16 15 14 13 12 11 10 9 8 7 6 5 4 3 2 1 0																														
ID	A A																														
Reset 0x00000000	0 0																														
ID	Acce Field	Value ID	Value	Description																											
A	RW	BASE0		Base address 0 Radio base address 0.																											

6.14.14.35 BASE1

Address offset: 0x520

Base address 1

Bit number	31 30 29 28 27 26 25 24 23 22 21 20 19 18 17 16 15 14 13 12 11 10 9 8 7 6 5 4 3 2 1 0																														
ID	A A																														
Reset 0x00000000	0 0																														
ID	Acce Field	Value ID	Value	Description																											
A	RW	BASE1		Base address 1 Radio base address 1.																											

6.14.14.36 PREFIX0

Address offset: 0x524

Prefixes bytes for logical addresses 0-3

Bit number	31 30 29 28 27 26 25 24 23 22 21 20 19 18 17 16 15 14 13 12 11 10 9 8 7 6 5 4 3 2 1 0																															
ID	D D D D D D D D C C C C C C C C C C B B B B B B B B A A A A A A A A																															
Reset 0x00000000	0 0																															
ID	Acce Field	Value ID	Value	Description																												
A-D	RW	AP[i] (i=0..3)		Address prefix i.																												

6.14.14.37 PREFIX1

Address offset: 0x528

Prefixes bytes for logical addresses 4-7

Bit number	31 30 29 28 27 26 25 24 23 22 21 20 19 18 17 16 15 14 13 12 11 10 9 8 7 6 5 4 3 2 1 0																															
ID	D D D D D D D D C C C C C C C C C C B B B B B B B B A A A A A A A A																															
Reset 0x00000000	0 0																															
ID	Acce Field	Value ID	Value	Description																												
A-D	RW	AP[i] (i=4..7)		Address prefix i.																												

6.14.14.38 TXADDRESS

Address offset: 0x52C

Transmit address select

Bit number	31 30 29 28 27 26 25 24 23 22 21 20 19 18 17 16 15 14 13 12 11 10 9 8 7 6 5 4 3 2 1 0																															
ID	A A A																															
Reset 0x00000000	0 0																															
ID	Acce Field	Value ID	Value	Description																												
A	RW	TXADDRESS		Transmit address select																												
				Logical address to be used when transmitting a packet.																												

6.14.14.39 RXADDRESSES

Address offset: 0x530

Receive address select

Bit number	31 30 29 28 27 26 25 24 23 22 21 20 19 18 17 16 15 14 13 12 11 10 9 8 7 6 5 4 3 2 1 0																															
ID	H G F E D C B A																															
Reset 0x00000000	0 0																															
ID	Acce Field	Value ID	Value	Description																												
A-H	RW	ADDR[i] (i=0..7)		Enable or disable reception on logical address i.																												
		Disabled	0	Disable																												
		Enabled	1	Enable																												

6.14.14.40 CRC CNF

Address offset: 0x534

CRC configuration

Bit number	31 30 29 28 27 26 25 24 23 22 21 20 19 18 17 16 15 14 13 12 11 10 9 8 7 6 5 4 3 2 1 0																														
ID																													B	A A	
Reset 0x00000000	0 0																														
ID	Acce Field	Value ID	Value	Description																											
A	RW LEN		[1..3]	CRC length in number of bytes.																											
		Disabled	0	CRC length is zero and CRC calculation is disabled																											
		One	1	CRC length is one byte and CRC calculation is enabled																											
		Two	2	CRC length is two bytes and CRC calculation is enabled																											
	Three	3	CRC length is three bytes and CRC calculation is enabled																												
B	RW SKIPADDR			Include or exclude packet address field out of CRC calculation.																											
		Include	0	CRC calculation includes address field																											
		Skip	1	CRC calculation does not include address field. The CRC calculation will start at the first byte after the address.																											

6.14.14.41 CRCPOLY

Address offset: 0x538

CRC polynomial

Bit number	31 30 29 28 27 26 25 24 23 22 21 20 19 18 17 16 15 14 13 12 11 10 9 8 7 6 5 4 3 2 1 0																														
ID																													A A		
Reset 0x00000000	0 0																														
ID	Acce Field	Value ID	Value	Description																											
A	RW CRCPOLY			CRC polynomial																											
<p>Each term in the CRC polynomial is mapped to a bit in this register which index corresponds to the term's exponent. The least significant term/bit is hard-wired internally to 1, and bit number 0 of the register content is ignored by the hardware. The following example is for an 8 bit CRC polynomial: $x^8 + x^7 + x^3 + x^2 + 1 = 1\ 1000\ 1101$.</p>																															

6.14.14.42 CRCINIT

Address offset: 0x53C

CRC initial value

Bit number	31 30 29 28 27 26 25 24 23 22 21 20 19 18 17 16 15 14 13 12 11 10 9 8 7 6 5 4 3 2 1 0																														
ID																													A A		
Reset 0x00000000	0 0																														
ID	Acce Field	Value ID	Value	Description																											
A	RW CRCINIT			CRC initial value																											
<p>Initial value for CRC calculation.</p>																															

6.14.14.43 TIFS

Address offset: 0x544

Inter Frame Spacing in us

Bit number	31	30	29	28	27	26	25	24	23	22	21	20	19	18	17	16	15	14	13	12	11	10	9	8	7	6	5	4	3	2	1	0																										
ID																												A	A	A	A	A	A	A	A	A	A	A	A	A	A	A	A	A	A	A	A	A	A	A	A	A	A	A	A	A	A	
Reset	0x00000000																											0	0	0	0	0	0	0	0	0	0	0	0	0	0	0	0	0	0	0	0	0	0	0	0	0	0	0	0	0	0	0

ID	Acce Field	Value ID	Value	Description
A	RW	TIFS		Inter Frame Spacing in us Inter frame space is the time interval between two consecutive packets. It is defined as the time, in micro seconds, from the end of the last bit of the previous packet to the start of the first bit of the subsequent packet.

6.14.14.44 RSSISAMPLE

Address offset: 0x548

RSSI sample

Bit number	31	30	29	28	27	26	25	24	23	22	21	20	19	18	17	16	15	14	13	12	11	10	9	8	7	6	5	4	3	2	1	0																										
ID																												A	A	A	A	A	A	A	A	A	A	A	A	A	A	A	A	A	A	A	A	A	A	A	A	A	A	A	A	A		
Reset	0x00000000																											0	0	0	0	0	0	0	0	0	0	0	0	0	0	0	0	0	0	0	0	0	0	0	0	0	0	0	0	0	0	0

ID	Acce Field	Value ID	Value	Description
A	R	RSSISAMPLE	[0..127]	RSSI sample RSSI sample result. The value of this register is read as a positive value while the actual received signal strength is a negative value. Actual received signal strength is therefore as follows: received signal strength = -A dBm

6.14.14.45 STATE

Address offset: 0x550

Current radio state

Bit number	31	30	29	28	27	26	25	24	23	22	21	20	19	18	17	16	15	14	13	12	11	10	9	8	7	6	5	4	3	2	1	0																										
ID																												A	A	A	A	A	A	A	A	A	A	A	A	A	A	A	A	A	A	A	A	A	A	A	A	A	A	A	A	A		
Reset	0x00000000																											0	0	0	0	0	0	0	0	0	0	0	0	0	0	0	0	0	0	0	0	0	0	0	0	0	0	0	0	0	0	0

ID	Acce Field	Value ID	Value	Description
A	R	STATE		Current radio state
		Disabled	0	RADIO is in the Disabled state
		RxRu	1	RADIO is in the RXRU state
		RxIdle	2	RADIO is in the RXIDLE state
		Rx	3	RADIO is in the RX state
		RxDisable	4	RADIO is in the RXDISABLED state
		TxRu	9	RADIO is in the TXRU state
		TxIdle	10	RADIO is in the TXIDLE state
		Tx	11	RADIO is in the TX state
		TxDisable	12	RADIO is in the TXDISABLED state

6.14.14.46 DATAWHITEIV

Address offset: 0x554

Data whitening initial value

Bit number	31	30	29	28	27	26	25	24	23	22	21	20	19	18	17	16	15	14	13	12	11	10	9	8	7	6	5	4	3	2	1	0
ID	A A A A A A A A																															
Reset 0x00000040	0 1 0 0 0 0 0 0																															
ID	Acce Field	Value ID	Value	Description																												
A	RW	DATAWHITEIV		Data whitening initial value. Bit 6 is hard-wired to '1', writing '0' to it has no effect, and it will always be read back and used by the device as '1'. Bit 0 corresponds to Position 6 of the LSFR, Bit 1 to Position 5, etc.																												

6.14.14.47 BCC

Address offset: 0x560

Bit counter compare

Bit number	31	30	29	28	27	26	25	24	23	22	21	20	19	18	17	16	15	14	13	12	11	10	9	8	7	6	5	4	3	2	1	0
ID	A A																															
Reset 0x00000000	0 0																															
ID	Acce Field	Value ID	Value	Description																												
A	RW	BCC		Bit counter compare Bit counter compare register																												

6.14.14.48 DAB[n] (n=0..7)

Address offset: 0x600 + (n × 0x4)

Device address base segment n

Bit number	31	30	29	28	27	26	25	24	23	22	21	20	19	18	17	16	15	14	13	12	11	10	9	8	7	6	5	4	3	2	1	0
ID	A A																															
Reset 0x00000000	0 0																															
ID	Acce Field	Value ID	Value	Description																												
A	RW	DAB		Device address base segment n																												

6.14.14.49 DAP[n] (n=0..7)

Address offset: 0x620 + (n × 0x4)

Device address prefix n

Bit number	31	30	29	28	27	26	25	24	23	22	21	20	19	18	17	16	15	14	13	12	11	10	9	8	7	6	5	4	3	2	1	0
ID	A A																															
Reset 0x00000000	0 0																															
ID	Acce Field	Value ID	Value	Description																												
A	RW	DAP		Device address prefix n																												

6.14.14.50 DACNF

Address offset: 0x640

Device address match configuration

Bit number	31 30 29 28 27 26 25 24 23 22 21 20 19 18 17 16 15 14 13 12 11 10 9 8 7 6 5 4 3 2 1 0																																																								
ID																															P	O	N	M	L	K	J	I	H	G	F	E	D	C	B	A											
Reset 0x00000000	0 0																																																								
ID	Acce Field	Value ID	Value	Description																																																					
A-H	RW	ENA[i] (i=0..7)		Enable or disable device address matching using device address i																																																					
		Disabled	0	Disabled																																																					
		Enabled	1	Enabled																																																					
I-P	RW	TXADD[i] (i=0..7)		TxAdd for device address i																																																					

6.14.14.51 MODECNF0

Address offset: 0x650

Radio mode configuration register 0

Bit number	31 30 29 28 27 26 25 24 23 22 21 20 19 18 17 16 15 14 13 12 11 10 9 8 7 6 5 4 3 2 1 0																																
ID																													C	C			A
Reset 0x00000200	0 0																																
ID	Acce Field	Value ID	Value	Description																													
A	RW	RU		Radio ramp-up time																													
		Default	0	Default ramp-up time (tRXEN), compatible with firmware written for nRF51																													
		Fast	1	Fast ramp-up (tRXEN,FAST), see electrical specification for more information																													
C	RW	DTX		Default TX value																													
				Specifies what the RADIO will transmit when it is not started, i.e. between:																													
				RADIO.EVENTS_READY and RADIO.TASKS_START																													
				RADIO.EVENTS_END and RADIO.TASKS_START																													
				RADIO.EVENTS_END and RADIO.EVENTS_DISABLED																													
		B1	0	Transmit '1'																													
		B0	1	Transmit '0'																													
		Center	2	Transmit center frequency																													
				When tuning the crystal for centre frequency, the RADIO must be set in DTX = Center mode to be able to achieve the expected accuracy.																													

6.14.14.52 POWER

Address offset: 0xFFC

Peripheral power control

Bit number	31 30 29 28 27 26 25 24 23 22 21 20 19 18 17 16 15 14 13 12 11 10 9 8 7 6 5 4 3 2 1 0																														
ID																															A
Reset 0x00000001	0 1																														
ID	Acce Field	Value ID	Value	Description																											
A	RW	POWER		Peripheral power control. The peripheral and its registers will be reset to its initial state by switching the peripheral off and then back on again.																											
		Disabled	0	Peripheral is powered off																											
		Enabled	1	Peripheral is powered on																											

6.14.15 Electrical specification

6.14.15.1 General radio characteristics

Symbol	Description	Min.	Typ.	Max.	Units
f_{OP}	Operating frequencies	2360		2500	MHz
$f_{PLL,PROG,RES}$	PLL programming resolution		2		kHz
$f_{PLL,CH,SP}$	PLL channel spacing		1		MHz
$f_{DELTA,1M}$	Frequency deviation @ 1 Mbps		± 170		kHz
$f_{DELTA,BLE,1M}$	Frequency deviation @ BLE 1 Mbps		± 250		kHz
$f_{DELTA,2M}$	Frequency deviation @ 2 Mbps		± 320		kHz
$f_{DELTA,BLE,2M}$	Frequency deviation @ BLE 2 Mbps		± 500		kHz
f_{skSPS}	On-the-air data rate	1		2	Mbps

6.14.15.2 Radio current consumption (transmitter)

Symbol	Description	Min.	Typ.	Max.	Units
$I_{TX,PLUS4dBm,DCDC}$	TX only run current (DCDC, 3V) $P_{RF} = +4$ dBm		7.0		mA
$I_{TX,PLUS4dBm}$	TX only run current $P_{RF} = +4$ dBm		15.4		mA
$I_{TX,0dBm,DCDC}$	TX only run current (DCDC, 3V) $P_{RF} = 0$ dBm		4.6		mA
$I_{TX,0dBm}$	TX only run current $P_{RF} = 0$ dBm		10.1		mA
$I_{TX,MINUS4dBm,DCDC}$	TX only run current DCDC, 3V $P_{RF} = -4$ dBm		3.6		mA
$I_{TX,MINUS4dBm}$	TX only run current $P_{RF} = -4$ dBm		7.8		mA
$I_{TX,MINUS8dBm,DCDC}$	TX only run current DCDC, 3V $P_{RF} = -8$ dBm		3.2		mA
$I_{TX,MINUS8dBm}$	TX only run current $P_{RF} = -8$ dBm		6.8		mA
$I_{TX,MINUS12dBm,DCDC}$	TX only run current DCDC, 3V $P_{RF} = -12$ dBm		2.9		mA
$I_{TX,MINUS12dBm}$	TX only run current $P_{RF} = -12$ dBm		6.2		mA
$I_{TX,MINUS16dBm,DCDC}$	TX only run current DCDC, 3V $P_{RF} = -16$ dBm		2.7		mA
$I_{TX,MINUS16dBm}$	TX only run current $P_{RF} = -16$ dBm		5.7		mA
$I_{TX,MINUS20dBm,DCDC}$	TX only run current DCDC, 3V $P_{RF} = -20$ dBm		2.5		mA
$I_{TX,MINUS20dBm}$	TX only run current $P_{RF} = -20$ dBm		5.4		mA
$I_{TX,MINUS40dBm,DCDC}$	TX only run current DCDC, 3V $P_{RF} = -40$ dBm		2.1		mA
$I_{TX,MINUS40dBm}$	TX only run current $P_{RF} = -40$ dBm		4.3		mA

6.14.15.3 Radio current consumption (receiver)

Symbol	Description	Min.	Typ.	Max.	Units
$I_{RX,1M,DCDC}$	RX only run current (DCDC, 3V) 1 Mbps / 1 Mbps BLE		4.6		mA
$I_{RX,1M}$	RX only run current 1 Mbps / 1 Mbps BLE		10.0		mA
$I_{RX,2M,DCDC}$	RX only run current (DCDC, 3V) 2 Mbps / 2 Mbps BLE		5.2		mA
$I_{RX,2M}$	RX only run current 2 Mbps / 2 Mbps BLE		11.2		mA
$I_{START,RX,1M,DCDC}$	RX start-up current (DCDC, 3 V) 1 Mbps / 1 Mbps BLE		3.5		mA
$I_{START,RX,1M}$	RX start-up current 1 Mbps / 1 Mbps BLE		6.7		mA

6.14.15.4 Transmitter specification

Symbol	Description	Min.	Typ.	Max.	Units
P_{RF}	Maximum output power		4	8	dBm
P_{RFC}	RF power control range		24		dB
P_{RFCR}	RF power accuracy			± 4	dB
$P_{RF1,1}$	1st Adjacent Channel Transmit Power 1 MHz (1 Mbps)		-25		dBc

Symbol	Description	Min.	Typ.	Max.	Units
P _{RF2,1}	2nd Adjacent Channel Transmit Power 2 MHz (1 Mbps)		-50		dBc
P _{RF1,2}	1st Adjacent Channel Transmit Power 2 MHz (2 Mbps)		-25		dBc
P _{RF2,2}	2nd Adjacent Channel Transmit Power 4 MHz (2 Mbps)		-50		dBc

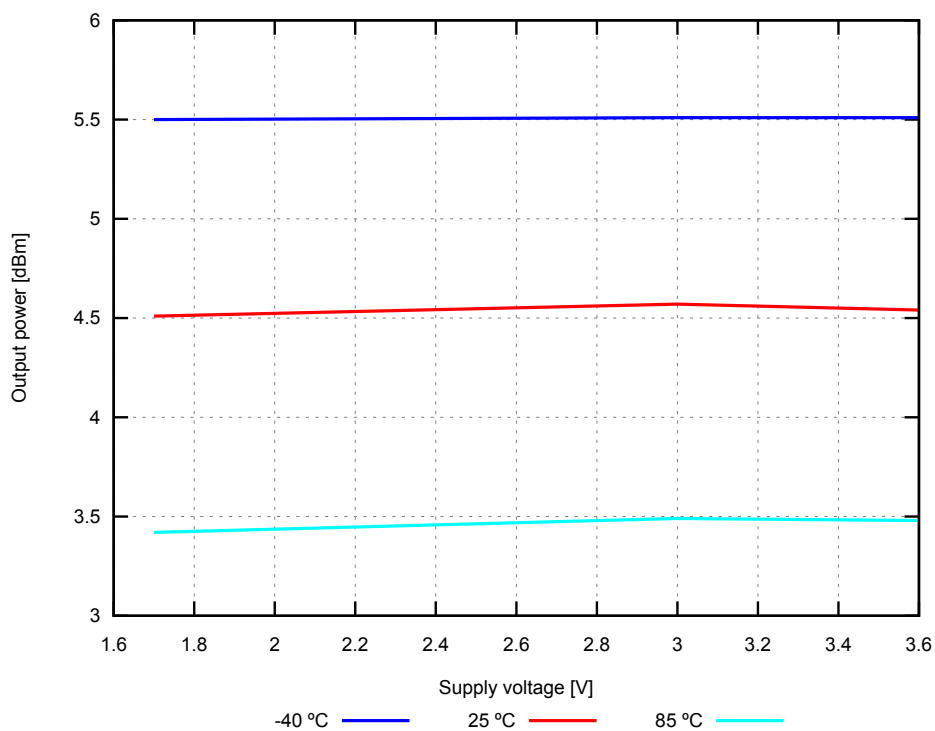

Figure 71: Output power, 1 Mbps Bluetooth low energy mode, 4 dBm TXPOWER setting (typical values)

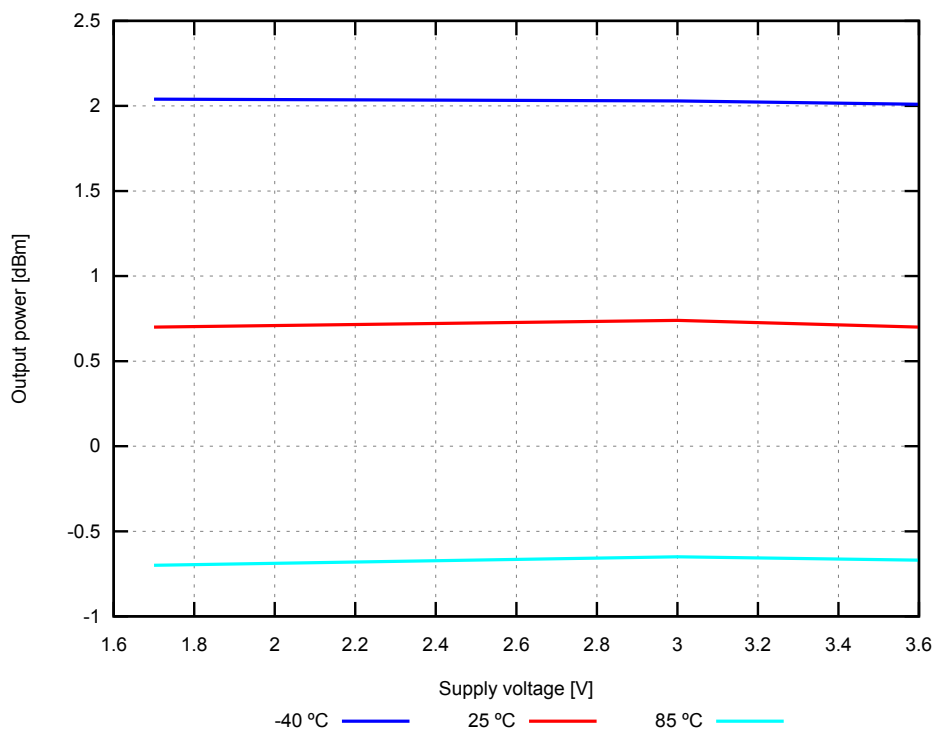

Figure 72: Output power, 1 Mbps Bluetooth low energy mode, 0 dBm TXPOWER setting (typical values)

6.14.15.5 Receiver operation

Symbol	Description	Min.	Typ.	Max.	Units
P _{RX,MAX}	Maximum received signal strength at < 0.1% BER		0		dBm
P _{SENS,IT,1M}	Sensitivity, 1 Mbps nRF mode ¹⁴		-93		dBm
P _{SENS,IT,SP,1M,BLE}	Sensitivity, 1 Mbps BLE ideal transmitter, <=37 bytes BER=1E-3 ¹⁵		-96		dBm
P _{SENS,IT,LP,1M,BLE}	Sensitivity, 1 Mbps BLE ideal transmitter >=128 bytes BER=1E-4 ¹⁶		-95		dBm
P _{SENS,IT,2M}	Sensitivity, 2 Mbps nRF mode ¹⁷		-89		dBm
P _{SENS,IT,SP,2M,BLE}	Sensitivity, 2 Mbps BLE ideal transmitter, Packet length <=37bytes		-93		dBm

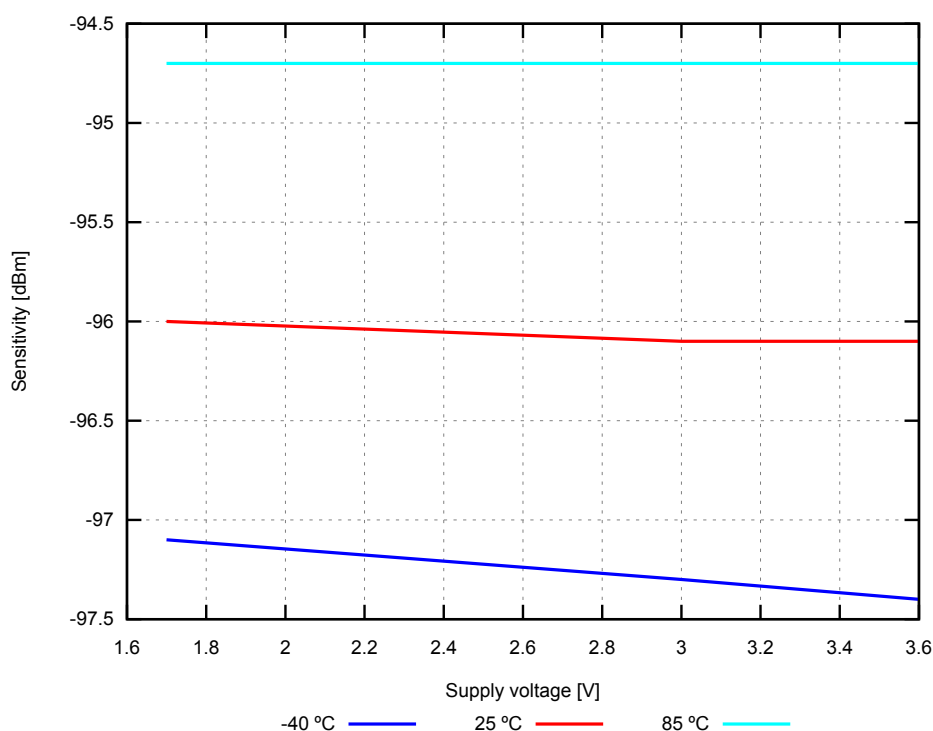

Figure 73: Sensitivity, 1 Mbps Bluetooth low energy mode, Regulator = LDO (typical values)

6.14.15.6 RX selectivity

RX selectivity with equal modulation on interfering signal¹⁸

¹⁴ Typical sensitivity applies when ADDR0 is used for receiver address correlation. When ADDR[1...7] are used for receiver address correlation, the typical sensitivity for this mode is degraded by 3dB.

¹⁵ As defined in the Bluetooth Core Specification v4.0 Volume 6: Core System Package (Low Energy Controller Volume)

¹⁶ Equivalent BER limit < 10E-04

¹⁷ Typical sensitivity applies when ADDR0 is used for receiver address correlation. When ADDR[1...7] are used for receiver address correlation, the typical sensitivity for this mode is degraded by 3dB.

¹⁸ Wanted signal level at PIN = -67 dBm. One interferer is used, having equal modulation as the wanted signal. The input power of the interferer where the sensitivity equals BER = 0.1% is presented

Symbol	Description	Min.	Typ.	Max.	Units
C/l _{1M,co-channel}	1 Mbps mode, Co-Channel interference		9		dB
C/l _{1M,-1MHz}	1 Mbps mode, Adjacent (-1 MHz) interference		-2		dB
C/l _{1M,+1MHz}	1 Mbps mode, Adjacent (+1 MHz) interference		-10		dB
C/l _{1M,-2MHz}	1 Mbps mode, Adjacent (-2 MHz) interference		-19		dB
C/l _{1M,+2MHz}	1 Mbps mode, Adjacent (+2 MHz) interference		-42		dB
C/l _{1M,-3MHz}	1 Mbps mode, Adjacent (-3 MHz) interference		-38		dB
C/l _{1M,+3MHz}	1 Mbps mode, Adjacent (+3 MHz) interference		-48		dB
C/l _{1M,±6MHz}	1 Mbps mode, Adjacent (≥6 MHz) interference		-50		dB
C/l _{1MBLE,co-channel}	1 Mbps BLE mode, Co-Channel interference		6		dB
C/l _{1MBLE,-1MHz}	1 Mbps BLE mode, Adjacent (-1 MHz) interference		-2		dB
C/l _{1MBLE,+1MHz}	1 Mbps BLE mode, Adjacent (+1 MHz) interference		-9		dB
C/l _{1MBLE,-2MHz}	1 Mbps BLE mode, Adjacent (-2 MHz) interference		-22		dB
C/l _{1MBLE,+2MHz}	1 Mbps BLE mode, Adjacent (+2 MHz) interference		-46		dB
C/l _{1MBLE,>3MHz}	1 Mbps BLE mode, Adjacent (≥3 MHz) interference		-50		dB
C/l _{1MBLE,image}	Image frequency Interference		-22		dB
C/l _{1MBLE,image,1MHz}	Adjacent (1 MHz) interference to in-band image frequency		-35		dB
C/l _{2M,co-channel}	2 Mbps mode, Co-Channel interference		10		dB
C/l _{2M,-2MHz}	2 Mbps mode, Adjacent (-2 MHz) interference		6		dB
C/l _{2M,+2MHz}	2 Mbps mode, Adjacent (+2 MHz) interference		-14		dB
C/l _{2M,-4MHz}	2 Mbps mode, Adjacent (-4 MHz) interference		-20		dB
C/l _{2M,+4MHz}	2 Mbps mode, Adjacent (+4 MHz) interference		-44		dB
C/l _{2M,-6MHz}	2 Mbps mode, Adjacent (-6 MHz) interference		-42		dB
C/l _{2M,+6MHz}	2 Mbps mode, Adjacent (+6 MHz) interference		-47		dB
C/l _{2M,≥12MHz}	2 Mbps mode, Adjacent (≥12 MHz) interference		-52		dB

6.14.15.7 RX intermodulation

RX intermodulation¹⁹

Symbol	Description	Min.	Typ.	Max.	Units
P _{IMD,5TH,1M}	IMD performance, 1 Msps, 5th offset channel, Packet length ≤ 37 bytes		-33		dBm
P _{IMD,5TH,1M,BLE}	IMD performance, BLE 1 Msps, 5th offset channel, Packet length ≤ 37 bytes		-30		dBm
P _{IMD,5TH,2M}	IMD performance, 2 Msps, 5th offset channel, Packet length ≤ 37 bytes		-33		dBm
P _{IMD,5TH,2M,BLE}	IMD performance, BLE 2 Msps, 5th offset channel, Packet length ≤ 37 bytes		-31		dBm

6.14.15.8 Radio timing

Symbol	Description	Min.	Typ.	Max.	Units
t _{TXEN}	Time between TXEN task and READY event after channel FREQUENCY configured. Compatible with old devices.	140		140	μs
t _{TXEN,FAST}	Time between TXEN task and READY event after channel FREQUENCY configured (Fast Mode)	40		40	μs

¹⁹ Wanted signal level at PIN = -64 dBm. Two interferers with equal input power are used. The interferer closest in frequency is not modulated, the other interferer is modulated equal with the wanted signal. The input power of the interferers where the sensitivity equals BER = 0.1% is presented.

Symbol	Description	Min.	Typ.	Max.	Units
t _{TXDISABLE,1M}	Time between DISABLE task and DISABLED event when the radio was in TX for MODE = Nrf_1Mbit and MODE = Ble_1Mbit	6		6	μs
t _{TXDISABLE,2M}	Time between DISABLE task and DISABLED event when the radio was in TX and mode is set to 2 Mbps	4		4	μs
t _{RXEN}	Time between the RXEN task and READY event after channel FREQUENCY configured in default mode. Compatible with old devices.	140		140	μs
t _{RXEN,FAST}	Time between the RXEN task and READY event after channel FREQUENCY configured in fast mode	40		40	μs
t _{SWITCH}	The minimum time taken to switch from RX to TX or TX to RX when channel FREQUENCY unchanged		20		μs
t _{RXDISABLE}	Time between DISABLE task and DISABLED event when the radio was in RX	0		0	μs
t _{TXCHAIN}	Digital propagation delay (in radio only) when transmitting. Does not include EasyDMA access time.		0.6		μs
t _{RXCHAIN}	Digital propagation delay (in radio only) when receiving. Does not include EasyDMA access time.		9.4		μs
t _{RXCHAIN,2M}	Digital propagation delay in 2 Mbps mode (radio only) when receiving. Does not include EasyDMA access time.		5		μs

6.14.15.9 Received Signal Strength Indicator (RSSI) specifications

Symbol	Description	Min.	Typ.	Max.	Units
RSSI _{ACC}	RSSI Accuracy Valid range -90 to -20 dBm		±2		dB
RSSI _{RESOLUTION}	RSSI resolution		1		dB
RSSI _{PERIOD}	Sample period		0.25		μs

6.14.15.10 Jitter

Symbol	Description	Min.	Typ.	Max.	Units
t _{DISABLEDJITTER}	Jitter on DISABLED event relative to END event when shortcut between END and DISABLE is enabled.		0.25		μs
t _{READYJITTER}	Jitter on READY event relative to TXEN and RXEN task.		0.25		μs

6.15 RNG — Random number generator

The Random number generator (RNG) generates true non-deterministic random numbers based on internal thermal noise that are suitable for cryptographic purposes. The RNG does not require a seed value.

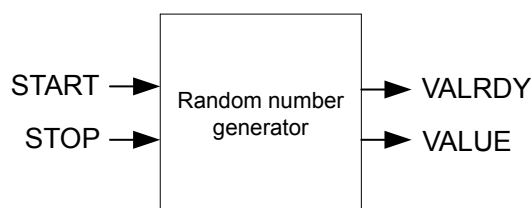

Figure 74: Random number generator

The RNG is started by triggering the START task and stopped by triggering the STOP task. When started, new random numbers are generated continuously and written to the VALUE register when ready. A VALRDY event is generated for every new random number that is written to the VALUE register. This means

that after a VALRDY event is generated the CPU has the time until the next VALRDY event to read out the random number from the VALUE register before it is overwritten by a new random number.

6.15.1 Bias correction

A bias correction algorithm is employed on the internal bit stream to remove any bias toward '1' or '0'. The bits are then queued into an eight-bit register for parallel readout from the VALUE register.

It is possible to enable bias correction in the CONFIG register. This will result in slower value generation, but will ensure a statistically uniform distribution of the random values.

6.15.2 Speed

The time needed to generate one random byte of data is unpredictable, and may vary from one byte to the next. This is especially true when bias correction is enabled.

6.15.3 Registers

Base address	Peripheral	Instance	Description	Configuration
0x4000D000	RNG	RNG	Random number generator	

Table 63: Instances

Register	Offset	Description
TASKS_START	0x000	Task starting the random number generator
TASKS_STOP	0x004	Task stopping the random number generator
EVENTS_VALRDY	0x100	Event being generated for every new random number written to the VALUE register
SHORTS	0x200	Shortcuts between local events and tasks
INTENSET	0x304	Enable interrupt
INTENCLR	0x308	Disable interrupt
CONFIG	0x504	Configuration register
VALUE	0x508	Output random number

Table 64: Register overview

6.15.3.1 TASKS_START

Address offset: 0x000

Task starting the random number generator

Bit number	31 30 29 28 27 26 25 24 23 22 21 20 19 18 17 16 15 14 13 12 11 10 9 8 7 6 5 4 3 2 1 0																															
ID																																A
Reset 0x00000000	0 0																															
ID	Acce	Field	Value ID	Value	Description																											
A	W	TASKS_START			Task starting the random number generator																											
			Trigger	1	Trigger task																											

6.15.3.2 TASKS_STOP

Address offset: 0x004

Task stopping the random number generator

Bit number	31	30	29	28	27	26	25	24	23	22	21	20	19	18	17	16	15	14	13	12	11	10	9	8	7	6	5	4	3	2	1	0
ID																																A
Reset 0x00000000	0 0																															
ID	Acce Field	Value ID	Value	Description																												
A	W TASKS_STOP	Trigger	1	Task stopping the random number generator Trigger task																												

6.15.3.3 EVENTS_VALRDY

Address offset: 0x100

Event being generated for every new random number written to the VALUE register

Bit number	31	30	29	28	27	26	25	24	23	22	21	20	19	18	17	16	15	14	13	12	11	10	9	8	7	6	5	4	3	2	1	0
ID																																A
Reset 0x00000000	0 0																															
ID	Acce Field	Value ID	Value	Description																												
A	RW EVENTS_VALRDY	NotGenerated	0	Event being generated for every new random number written to the VALUE register Event not generated																												
		Generated	1	Event generated																												

6.15.3.4 SHORTS

Address offset: 0x200

Shortcuts between local events and tasks

Bit number	31	30	29	28	27	26	25	24	23	22	21	20	19	18	17	16	15	14	13	12	11	10	9	8	7	6	5	4	3	2	1	0
ID																																A
Reset 0x00000000	0 0																															
ID	Acce Field	Value ID	Value	Description																												
A	RW VALRDY_STOP	Disabled	0	Shortcut between event VALRDY and task STOP Disable shortcut																												
		Enabled	1	Enable shortcut																												

6.15.3.5 INTENSET

Address offset: 0x304

Enable interrupt

Bit number	31	30	29	28	27	26	25	24	23	22	21	20	19	18	17	16	15	14	13	12	11	10	9	8	7	6	5	4	3	2	1	0
ID																																A
Reset 0x00000000	0 0																															
ID	Acce Field	Value ID	Value	Description																												
A	RW VALRDY	Set	1	Write '1' to enable interrupt for event VALRDY Enable																												
		Disabled	0	Read: Disabled																												
		Enabled	1	Read: Enabled																												

6.15.3.6 INTENCLR

Address offset: 0x308

Disable interrupt

Bit number	31 30 29 28 27 26 25 24 23 22 21 20 19 18 17 16 15 14 13 12 11 10 9 8 7 6 5 4 3 2 1 0																																
ID	A																																
Reset	0x00000000																																
0	0	0	0	0	0	0	0	0	0	0	0	0	0	0	0	0	0	0	0	0	0	0	0	0	0	0	0	0	0	0	0	0	0
ID	Acce Field	Value ID	Value	Description																													
A	RW VALRDY			Write '1' to disable interrupt for event VALRDY																													
		Clear	1	Disable																													
		Disabled	0	Read: Disabled																													
		Enabled	1	Read: Enabled																													

6.15.3.7 CONFIG

Address offset: 0x504

Configuration register

Bit number	31 30 29 28 27 26 25 24 23 22 21 20 19 18 17 16 15 14 13 12 11 10 9 8 7 6 5 4 3 2 1 0																																
ID	A																																
Reset	0x00000000																																
0	0	0	0	0	0	0	0	0	0	0	0	0	0	0	0	0	0	0	0	0	0	0	0	0	0	0	0	0	0	0	0	0	0
ID	Acce Field	Value ID	Value	Description																													
A	RW DERCEN			Bias correction																													
		Disabled	0	Disabled																													
		Enabled	1	Enabled																													

6.15.3.8 VALUE

Address offset: 0x508

Output random number

Bit number	31 30 29 28 27 26 25 24 23 22 21 20 19 18 17 16 15 14 13 12 11 10 9 8 7 6 5 4 3 2 1 0																																																									
ID																													A	A	A	A	A	A	A	A	A	A	A	A	A	A	A	A	A	A	A	A	A	A	A	A	A	A	A	A	A	A
Reset	0x00000000																																																									
0	0	0	0	0	0	0	0	0	0	0	0	0	0	0	0	0	0	0	0	0	0	0	0	0	0	0	0	0	0	0	0	0	0																									
ID	Acce Field	Value ID	Value	Description																																																						
A	R VALUE		[0..255]	Generated random number																																																						

6.15.4 Electrical specification

6.15.4.1 RNG Electrical Specification

Symbol	Description	Min.	Typ.	Max.	Units
t _{RNG,START}	Time from setting the START task to generation begins. This is a one-time delay on START signal and does not apply between samples.		128		µs
t _{RNG,RAW}	Run time per byte without bias correction. Uniform distribution of 0 and 1 is not guaranteed.		30		µs
t _{RNG,BC}	Run time per byte with bias correction. Uniform distribution of 0 and 1 is guaranteed. Time to generate a byte cannot be guaranteed.		120		µs

6.16 RTC — Real-time counter

The Real-time counter (RTC) module provides a generic, low power timer on the low-frequency clock source (LFCLK).

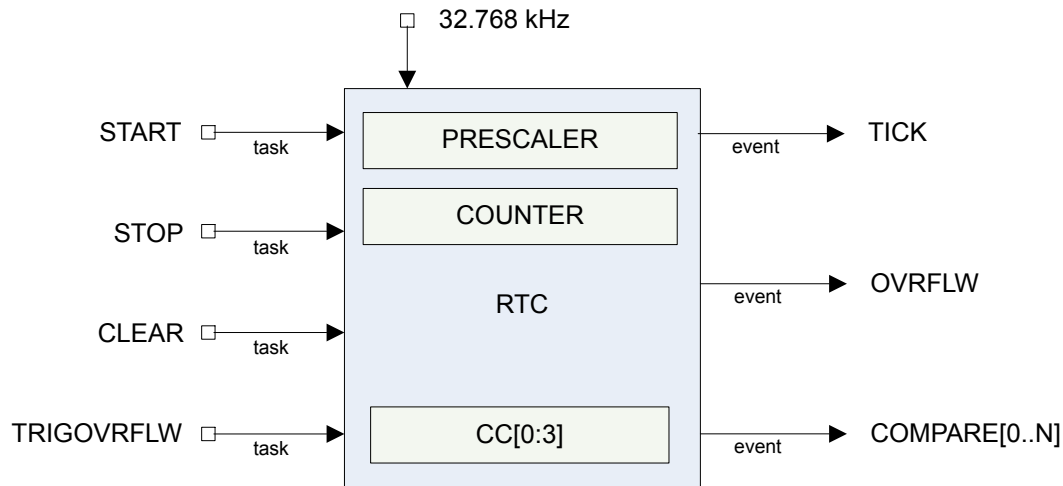

Figure 75: RTC block schematic

The RTC module features a 24-bit COUNTER, a 12-bit (1/X) prescaler, capture/compare registers, and a tick event generator for low power, tickless RTOS implementation.

6.16.1 Clock source

The RTC will run off the LFCLK.

The COUNTER resolution will therefore be 30.517 μ s. Depending on the source, the RTC is able to run while the HFCLK is OFF and PCLK16M is not available.

The software has to explicitly start LFCLK before using the RTC.

See [CLOCK — Clock control](#) on page 62 for more information about clock sources.

6.16.2 Resolution versus overflow and the PRESCALER

Counter increment frequency:

$$f_{\text{RTC}} [\text{kHz}] = 32.768 / (\text{PRESCALER} + 1)$$

The PRESCALER register is read/write when the RTC is stopped. The PRESCALER register is read-only once the RTC is STARTed. Writing to the PRESCALER register when the RTC is started has no effect.

The PRESCALER is restarted on START, CLEAR and TRIGOVFLW, that is, the prescaler value is latched to an internal register (<<PRESC>>) on these tasks.

Examples:

1. Desired COUNTER frequency 100 Hz (10 ms counter period)

$$\text{PRESCALER} = \text{round}(32.768 \text{ kHz} / 100 \text{ Hz}) - 1 = 327$$

$$f_{\text{RTC}} = 99.9 \text{ Hz}$$

10009.576 μ s counter period

2. Desired COUNTER frequency 8 Hz (125 ms counter period)

$\text{PRESCALER} = \text{round}(32.768 \text{ kHz} / 8 \text{ Hz}) - 1 = 4095$

$f_{\text{RTC}} = 8 \text{ Hz}$

125 ms counter period

Prescaler	Counter resolution	Overflow
0	30.517 μ s	512 seconds
2^8-1	7812.5 μ s	131072 seconds
$2^{12}-1$	125 ms	582.542 hours

Table 65: RTC resolution versus overflow

6.16.3 COUNTER register

The COUNTER increments on LFCLK when the internal PRESCALER register (<<PRESC>>) is 0x00. <<PRESC>> is reloaded from the PRESCALER register. If enabled, the TICK event occurs on each increment of the COUNTER. The TICK event is disabled by default.

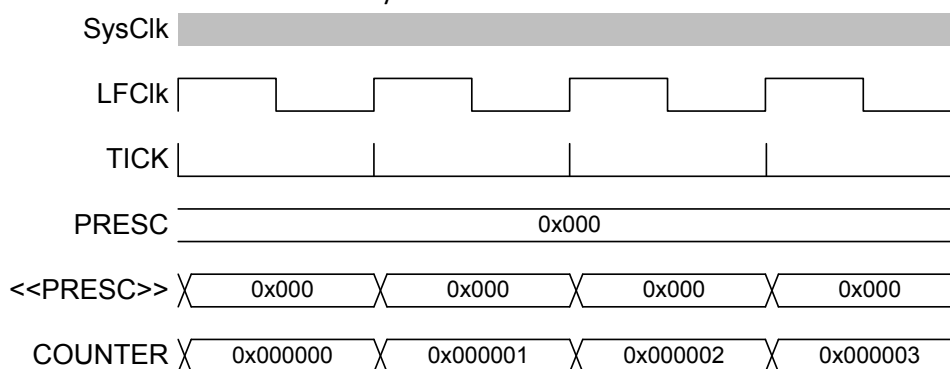

Figure 76: Timing diagram - COUNTER_PRESCALER_0

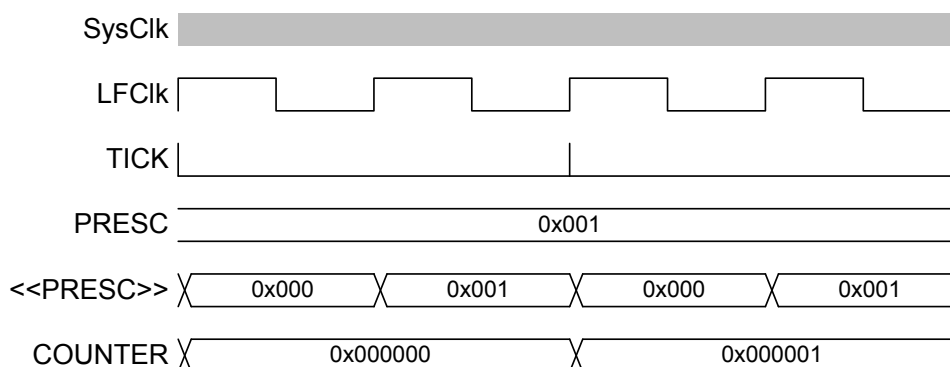

Figure 77: Timing diagram - COUNTER_PRESCALER_1

6.16.4 Overflow features

The TRIGOVFLW task sets the COUNTER value to 0xFFFFF0 to allow SW test of the overflow condition.

OVRFLW occurs when COUNTER overflows from 0xFFFFF0 to 0.

Important: The OVRFLW event is disabled by default.

6.16.5 TICK event

The TICK event enables low power "tick-less" RTOS implementation as it optionally provides a regular interrupt source for a RTOS without the need to use the ARM[®] SysTick feature.

Using the RTC TICK event rather than the SysTick allows the CPU to be powered down while still keeping RTOS scheduling active.

Important: The TICK event is disabled by default.

6.16.6 Event control feature

To optimize RTC power consumption, events in the RTC can be individually disabled to prevent PCLK16M and HFCLK being requested when those events are triggered. This is managed using the EVTEN register.

For example, if the TICK event is not required for an application, this event should be disabled as it is frequently occurring and may increase power consumption if HFCLK otherwise could be powered down for long durations.

This means that the RTC implements a slightly different task and event system compared to the standard system described in [Peripheral interface](#) on page 75. The RTC task and event system is illustrated in [Tasks, events and interrupts in the RTC](#) on page 220.

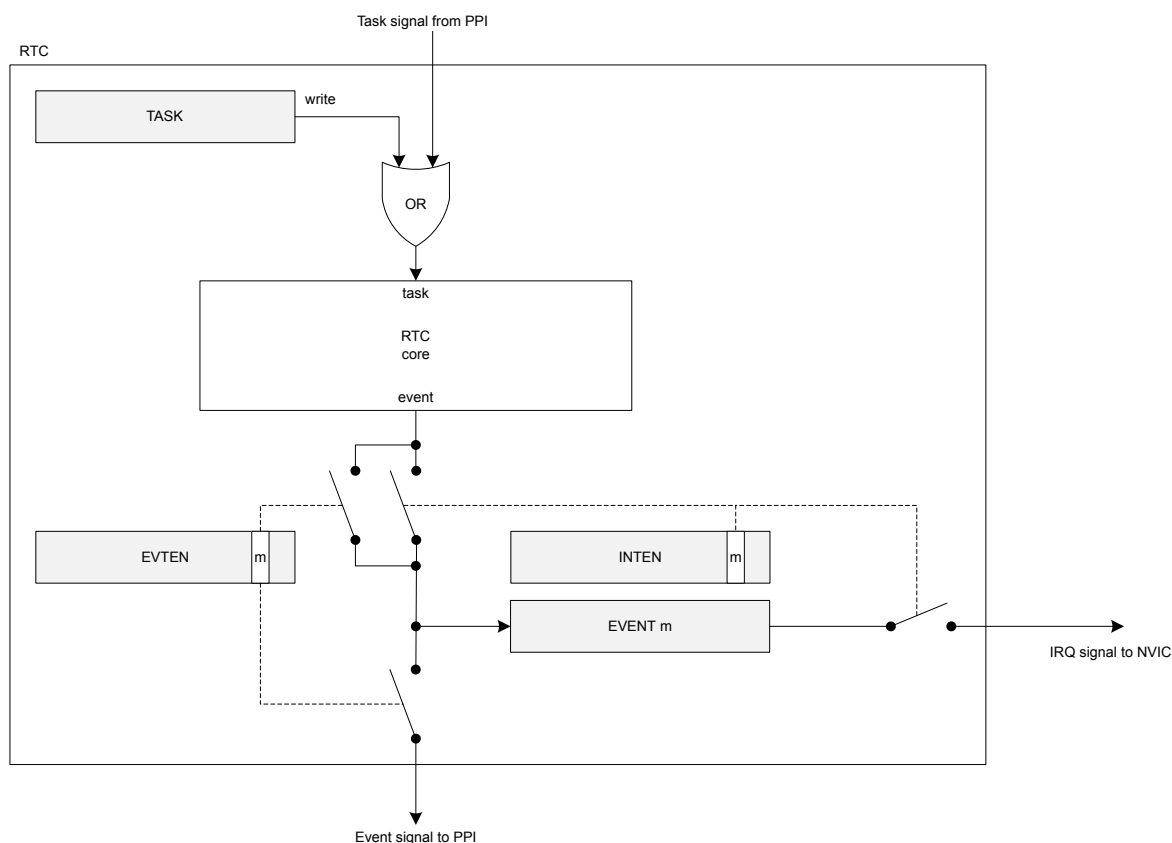

Figure 78: Tasks, events and interrupts in the RTC

6.16.7 Compare feature

There are a number of Compare registers.

For more information, see [Registers](#) on page 225.

When setting a compare register, the following behavior of the RTC compare event should be noted:

- If a CC register value is 0 when a CLEAR task is set, this will not trigger a COMPARE event.

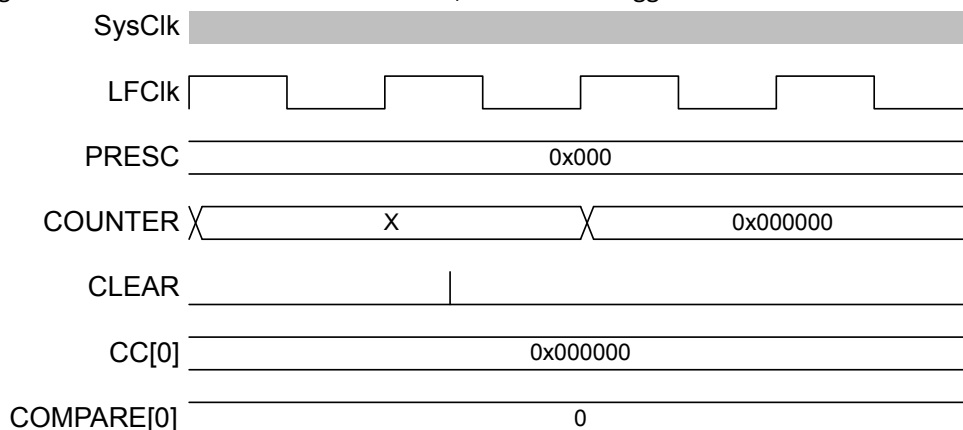

Figure 79: Timing diagram - COMPARE_CLEAR

- If a CC register is N and the COUNTER value is N when the START task is set, this will not trigger a COMPARE event.

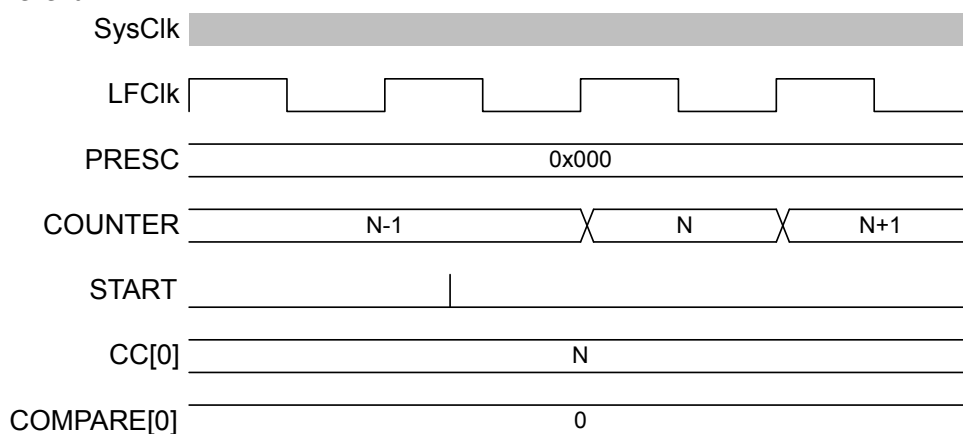

Figure 80: Timing diagram - COMPARE_START

- COMPARE occurs when a CC register is N and the COUNTER value transitions from N-1 to N.

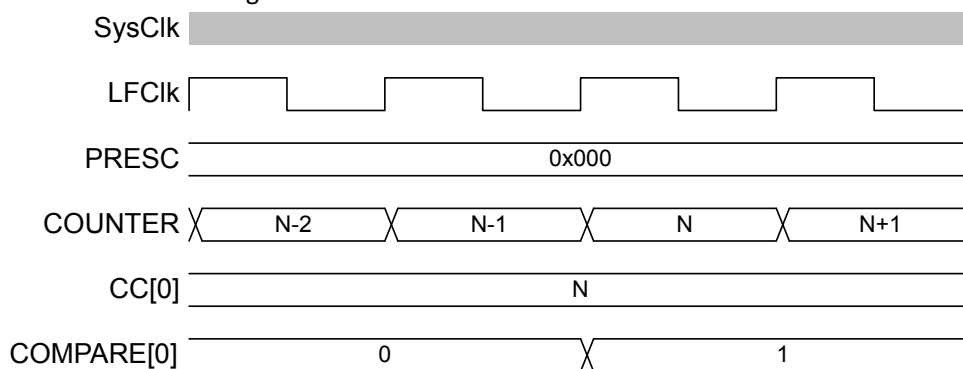

Figure 81: Timing diagram - COMPARE

- If the COUNTER is N, writing N+2 to a CC register is guaranteed to trigger a COMPARE event at N+2.

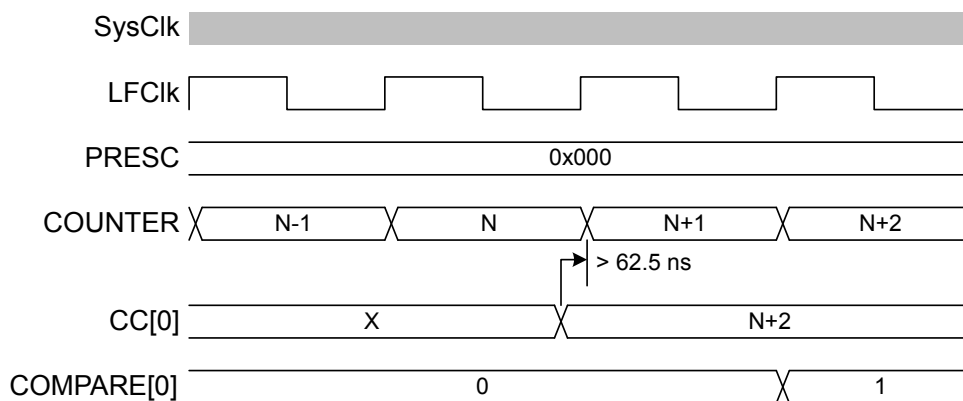

Figure 82: Timing diagram - COMPARE_N+2

- If the COUNTER is N, writing N or N+1 to a CC register may not trigger a COMPARE event.

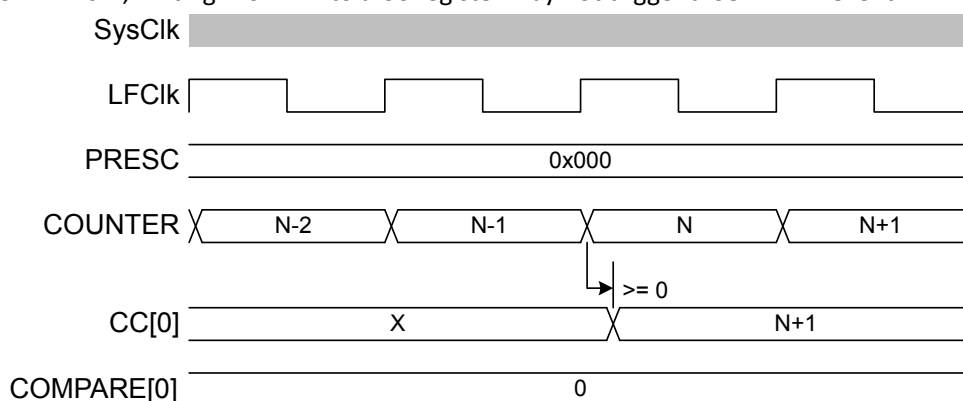

Figure 83: Timing diagram - COMPARE_N+1

- If the COUNTER is N and the current CC register value is N+1 or N+2 when a new CC value is written, a match may trigger on the previous CC value before the new value takes effect. If the current CC value greater than N+2 when the new value is written, there will be no event due to the old value.

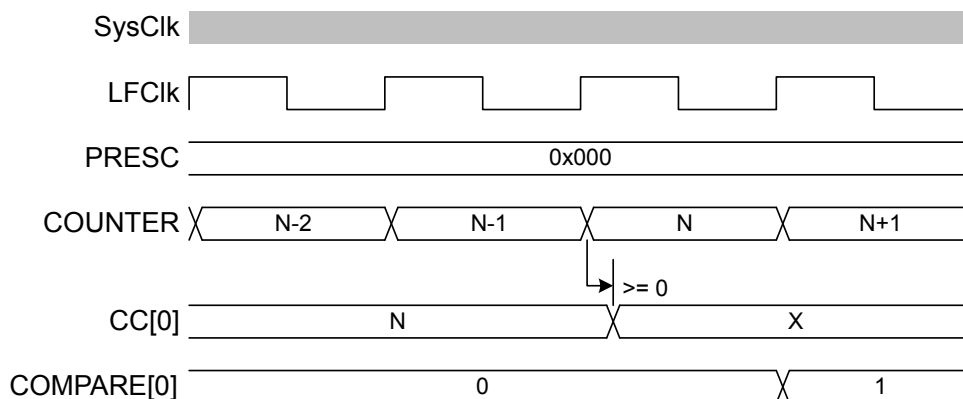

Figure 84: Timing diagram - COMPARE_N-1

6.16.8 TASK and EVENT jitter/delay

Jitter or delay in the RTC is due to the peripheral clock being a low frequency clock (LFCLK) which is not synchronous to the faster PCLK16M.

Registers in the peripheral interface, part of the PCLK16M domain, have a set of mirrored registers in the LFCLK domain. For example, the COUNTER value accessible from the CPU is in the PCLK16M domain and is latched on read from an internal register called COUNTER in the LFCLK domain. COUNTER is the register which is actually modified each time the RTC ticks. These registers must be synchronised between clock domains (PCLK16M and LFCLK).

The following is a summary of the jitter introduced on tasks and events. Figures illustrating jitter follow.

Task	Delay
CLEAR, STOP, START, TRIGOVRFLOW	+15 to 46 μ s

Table 66: RTC jitter magnitudes on tasks

Operation/Function	Jitter
START to COUNTER increment	+/- 15 μ s
COMPARE to COMPARE ²⁰	+/- 62.5 ns

Table 67: RTC jitter magnitudes on events

1. CLEAR and STOP (and TRIGOVRFLOW; not shown) will be delayed as long as it takes for the peripheral to clock a falling edge and rising of the LFCLK. This is between 15.2585 μ s and 45.775 μ s – rounded to 15 μ s and 46 μ s for the remainder of the section.

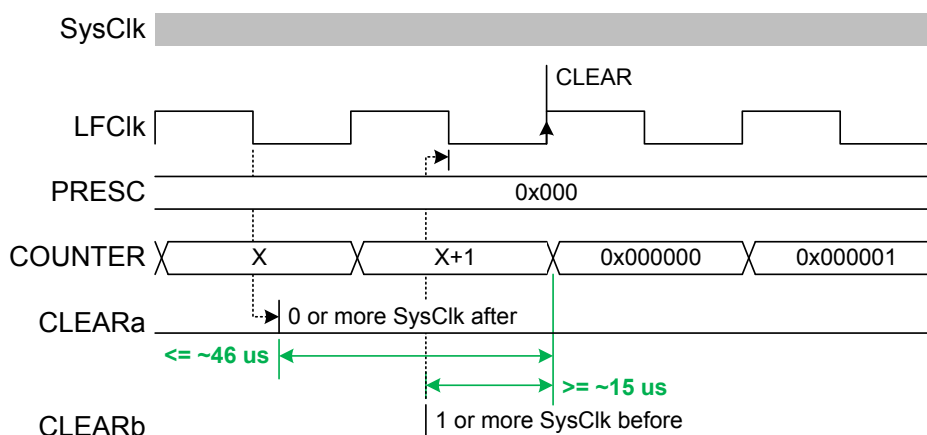

Figure 85: Timing diagram - DELAY_CLEAR

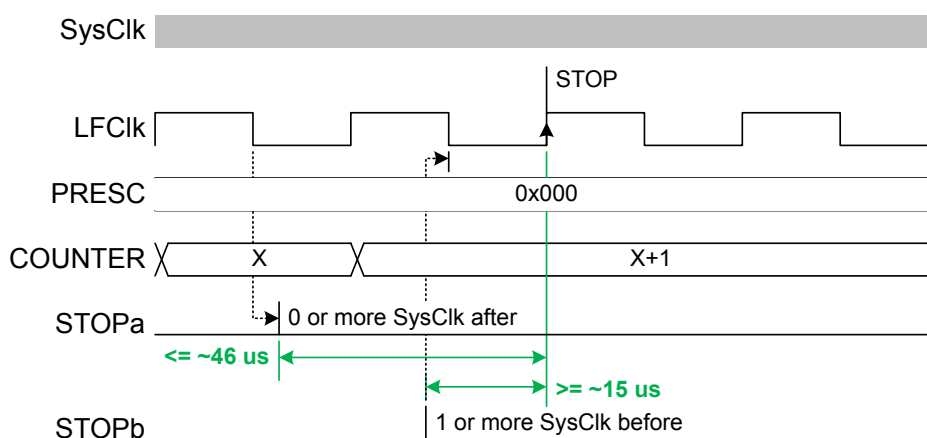

Figure 86: Timing diagram - DELAY_STOP

2. The START task will start the RTC. Assuming that the LFCLK was previously running and stable, the first increment of COUNTER (and instance of TICK event) will be typically after 30.5 μ s +/- 15 μ s. In some cases, in particular if the RTC is STARTed before the LFCLK is running, that timing can be up to ~250 μ s. The software should therefore wait for the first TICK if it has to make sure the RTC is running.

²⁰ Assumes RTC runs continuously between these events.

Note: 32.768 kHz clock jitter is additional to the numbers provided above.

Sending a TRIGOVFLW task sets the COUNTER to a value close to overflow. However, since the update of COUNTER relies on a stable LFCLK, sending this task while LFCLK is not running will start LFCLK, but the update will then be delayed by the same amount of time of up to ~250 μ s. The figures show the smallest and largest delays to on the START task which appears as a +/-15 μ s jitter on the first COUNTER increment.

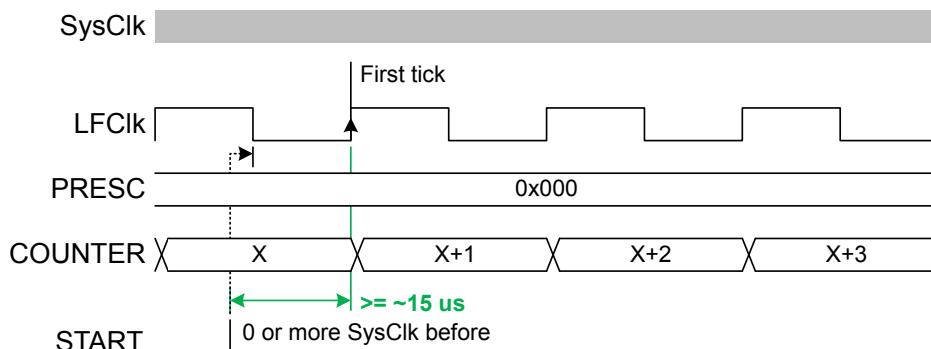

Figure 87: Timing diagram - JITTER_START-

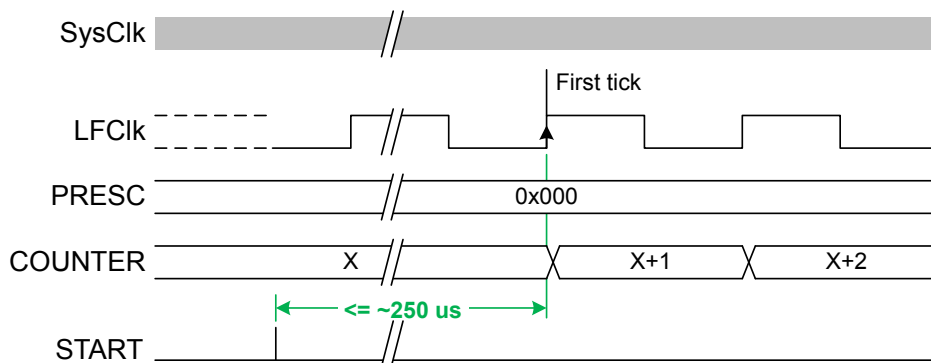

Figure 88: Timing diagram - JITTER_START+

6.16.9 Reading the COUNTER register

To read the COUNTER register, the internal <<COUNTER>> value is sampled.

To ensure that the <<COUNTER>> is safely sampled (considering an LFCLK transition may occur during a read), the CPU and core memory bus are halted for three cycles by lowering the core PREADY signal. The Read takes the CPU 2 cycles in addition resulting in the COUNTER register read taking a fixed five PCLK16M clock cycles.

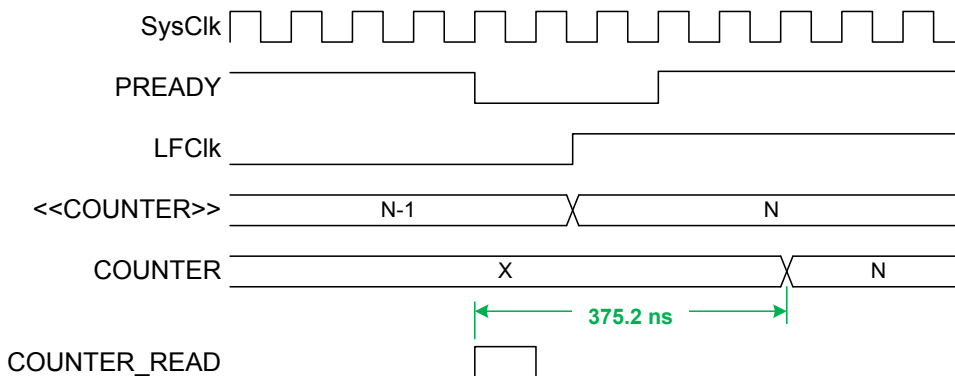

Figure 89: Timing diagram - COUNTER_READ

6.16.10 Registers

Base address	Peripheral	Instance	Description	Configuration
0x4000B000	RTC	RTC0	Real-time counter 0	CC[0..2] implemented, CC[3] not implemented
0x40011000	RTC	RTC1	Real-time counter 1	CC[0..3] implemented

Table 68: Instances

Register	Offset	Description
TASKS_START	0x000	Start RTC COUNTER
TASKS_STOP	0x004	Stop RTC COUNTER
TASKS_CLEAR	0x008	Clear RTC COUNTER
TASKS_TRIGOVFLW	0x00C	Set COUNTER to 0xFFFFF0
EVENTS_TICK	0x100	Event on COUNTER increment
EVENTS_OVRFLW	0x104	Event on COUNTER overflow
EVENTS_COMPARE[0]	0x140	Compare event on CC[0] match
EVENTS_COMPARE[1]	0x144	Compare event on CC[1] match
EVENTS_COMPARE[2]	0x148	Compare event on CC[2] match
EVENTS_COMPARE[3]	0x14C	Compare event on CC[3] match
INTENSET	0x304	Enable interrupt
INTENCLR	0x308	Disable interrupt
EVTEN	0x340	Enable or disable event routing
EVTENSET	0x344	Enable event routing
EVTENCLR	0x348	Disable event routing
COUNTER	0x504	Current COUNTER value
PRESCALER	0x508	12 bit prescaler for COUNTER frequency (32768/(PRESCALER+1)). Must be written when RTC is stopped
CC[0]	0x540	Compare register 0
CC[1]	0x544	Compare register 1
CC[2]	0x548	Compare register 2
CC[3]	0x54C	Compare register 3

Table 69: Register overview

6.16.10.1 TASKS_START

Address offset: 0x000

Start RTC COUNTER

Bit number	31 30 29 28 27 26 25 24 23 22 21 20 19 18 17 16 15 14 13 12 11 10 9 8 7 6 5 4 3 2 1 0																														
ID	A																														
Reset 0x00000000	0 0																														
ID	Acce	Field	Value	ID	Value	Description																									
A	W	TASKS_START				Start RTC COUNTER																									
			Trigger	1		Trigger task																									

6.16.10.2 TASKS_STOP

Address offset: 0x004

Stop RTC COUNTER

Bit number	31	30	29	28	27	26	25	24	23	22	21	20	19	18	17	16	15	14	13	12	11	10	9	8	7	6	5	4	3	2	1	0
ID																																A
Reset 0x00000000	0 0																															
ID	Acce Field	Value ID	Value	Description																												
A	W TASKS_STOP	Trigger	1	Stop RTC COUNTER Trigger task																												

6.16.10.3 TASKS_CLEAR

Address offset: 0x008

Clear RTC COUNTER

Bit number	31	30	29	28	27	26	25	24	23	22	21	20	19	18	17	16	15	14	13	12	11	10	9	8	7	6	5	4	3	2	1	0
ID																																A
Reset 0x00000000	0 0																															
ID	Acce Field	Value ID	Value	Description																												
A	W TASKS_CLEAR	Trigger	1	Clear RTC COUNTER Trigger task																												

6.16.10.4 TASKS_TRIGOVFLW

Address offset: 0x00C

Set COUNTER to 0xFFFFF0

Bit number	31	30	29	28	27	26	25	24	23	22	21	20	19	18	17	16	15	14	13	12	11	10	9	8	7	6	5	4	3	2	1	0
ID																																A
Reset 0x00000000	0 0																															
ID	Acce Field	Value ID	Value	Description																												
A	W TASKS_TRIGOVFLW	Trigger	1	Set COUNTER to 0xFFFFF0 Trigger task																												

6.16.10.5 EVENTS_TICK

Address offset: 0x100

Event on COUNTER increment

Bit number	31	30	29	28	27	26	25	24	23	22	21	20	19	18	17	16	15	14	13	12	11	10	9	8	7	6	5	4	3	2	1	0
ID																																A
Reset 0x00000000	0 0																															
ID	Acce Field	Value ID	Value	Description																												
A	RW EVENTS_TICK	NotGenerated	0	Event on COUNTER increment Event not generated																												
		Generated	1	Event generated																												

6.16.10.6 EVENTS_OVRFLW

Address offset: 0x104

Event on COUNTER overflow

Bit number	31	30	29	28	27	26	25	24	23	22	21	20	19	18	17	16	15	14	13	12	11	10	9	8	7	6	5	4	3	2	1	0	
ID																																A	
Reset	0x00000000																																
0	0	0	0	0	0	0	0	0	0	0	0	0	0	0	0	0	0	0	0	0	0	0	0	0	0	0	0	0	0	0	0	0	0
ID	Acce Field	Value ID	Value	Description																													
A	RW	EVENTS_OVRFLW		Event on COUNTER overflow																													
		NotGenerated	0	Event not generated																													
		Generated	1	Event generated																													

6.16.10.7 EVENTS_COMPARE[n] (n=0..3)

Address offset: 0x140 + (n × 0x4)

Compare event on CC[n] match

Bit number	31	30	29	28	27	26	25	24	23	22	21	20	19	18	17	16	15	14	13	12	11	10	9	8	7	6	5	4	3	2	1	0
ID																																A
Reset	0x00000000																															
0	0	0	0	0	0	0	0	0	0	0	0	0	0	0	0	0	0	0	0	0	0	0	0	0	0	0	0	0	0	0	0	0
ID	Acce Field	Value ID	Value	Description																												
A	RW	EVENTS_COMPARE		Compare event on CC[n] match																												
		NotGenerated	0	Event not generated																												
		Generated	1	Event generated																												

6.16.10.8 INTENSET

Address offset: 0x304

Enable interrupt

Bit number	31	30	29	28	27	26	25	24	23	22	21	20	19	18	17	16	15	14	13	12	11	10	9	8	7	6	5	4	3	2	1	0
ID														F	E	D	C														B	A
Reset	0x00000000																															
0	0	0	0	0	0	0	0	0	0	0	0	0	0	0	0	0	0	0	0	0	0	0	0	0	0	0	0	0	0	0	0	0
ID	Acce Field	Value ID	Value	Description																												
A	RW	TICK		Write '1' to enable interrupt for event TICK																												
		Set	1	Enable																												
		Disabled	0	Read: Disabled																												
		Enabled	1	Read: Enabled																												
B	RW	OVRFLW		Write '1' to enable interrupt for event OVRFLW																												
		Set	1	Enable																												
		Disabled	0	Read: Disabled																												
		Enabled	1	Read: Enabled																												
C-F	RW	COMPARE[i] (i=0..3)		Write '1' to enable interrupt for event COMPARE[i]																												
		Set	1	Enable																												
		Disabled	0	Read: Disabled																												
		Enabled	1	Read: Enabled																												

6.16.10.9 INTENCLR

Address offset: 0x308

Disable interrupt

Bit number	31 30 29 28 27 26 25 24 23 22 21 20 19 18 17 16 15 14 13 12 11 10 9 8 7 6 5 4 3 2 1 0																														
ID	F E D C																												B A		
Reset 0x00000000	0 0																														
ID	Acce Field	Value ID	Value	Description																											
A	RW TICK			Write '1' to disable interrupt for event TICK																											
		Clear	1	Disable																											
		Disabled	0	Read: Disabled																											
		Enabled	1	Read: Enabled																											
B	RW OVRFLW			Write '1' to disable interrupt for event OVRFLW																											
		Clear	1	Disable																											
		Disabled	0	Read: Disabled																											
		Enabled	1	Read: Enabled																											
C-F	RW COMPARE[i] (i=0..3)			Write '1' to disable interrupt for event COMPARE[i]																											
		Clear	1	Disable																											
		Disabled	0	Read: Disabled																											
		Enabled	1	Read: Enabled																											

6.16.10.10 EVTEN

Address offset: 0x340

Enable or disable event routing

Bit number	31 30 29 28 27 26 25 24 23 22 21 20 19 18 17 16 15 14 13 12 11 10 9 8 7 6 5 4 3 2 1 0																														
ID	F E D C																												B A		
Reset 0x00000000	0 0																														
ID	Acce Field	Value ID	Value	Description																											
A	RW TICK			Enable or disable event routing for event TICK																											
		Disabled	0	Disable																											
		Enabled	1	Disable																											
B	RW OVRFLW			Enable or disable event routing for event OVRFLW																											
		Disabled	0	Disable																											
		Enabled	1	Disable																											
C-F	RW COMPARE[i] (i=0..3)			Enable or disable event routing for event COMPARE[i]																											
		Disabled	0	Disable																											
		Enabled	1	Disable																											

6.16.10.11 EVTENSET

Address offset: 0x344

Enable event routing

Bit number	31 30 29 28 27 26 25 24 23 22 21 20 19 18 17 16 15 14 13 12 11 10 9 8 7 6 5 4 3 2 1 0																														
ID	F E D C																												B A		
Reset 0x00000000	0 0																														
ID	Acce Field	Value ID	Value	Description																											
A	RW TICK			Write '1' to enable event routing for event TICK																											
		Disabled	0	Read: Disabled																											
		Enabled	1	Read: Enabled																											
		Set	1	Enable																											
B	RW OVRFLW			Write '1' to enable event routing for event OVRFLW																											
		Disabled	0	Read: Disabled																											
		Enabled	1	Read: Enabled																											
		Set	1	Enable																											

Bit number	31 30 29 28 27 26 25 24 23 22 21 20 19 18 17 16 15 14 13 12 11 10 9 8 7 6 5 4 3 2 1 0																														
ID	F E D C																												B A		
Reset 0x00000000	0 0																														
ID	Acce Field	Value ID	Value	Description																											
C-F	RW COMPARE[i] (i=0..3)			Write '1' to enable event routing for event COMPARE[i]																											
		Disabled	0	Read: Disabled																											
		Enabled	1	Read: Enabled																											
		Set	1	Enable																											

6.16.10.12 EVTENCLR

Address offset: 0x348

Disable event routing

Bit number	31 30 29 28 27 26 25 24 23 22 21 20 19 18 17 16 15 14 13 12 11 10 9 8 7 6 5 4 3 2 1 0																														
ID	F E D C																												B A		
Reset 0x00000000	0 0																														
ID	Acce Field	Value ID	Value	Description																											
A	RW TICK			Write '1' to disable event routing for event TICK																											
		Disabled	0	Read: Disabled																											
		Enabled	1	Read: Enabled																											
		Clear	1	Disable																											
B	RW OVRFLW			Write '1' to disable event routing for event OVRFLW																											
		Disabled	0	Read: Disabled																											
		Enabled	1	Read: Enabled																											
		Clear	1	Disable																											
C-F	RW COMPARE[i] (i=0..3)			Write '1' to disable event routing for event COMPARE[i]																											
		Disabled	0	Read: Disabled																											
		Enabled	1	Read: Enabled																											
		Clear	1	Disable																											

6.16.10.13 COUNTER

Address offset: 0x504

Current COUNTER value

Bit number	31 30 29 28 27 26 25 24 23 22 21 20 19 18 17 16 15 14 13 12 11 10 9 8 7 6 5 4 3 2 1 0																														
ID																													A A		
Reset 0x00000000	0 0																														
ID	Acce Field	Value ID	Value	Description																											
A	R COUNTER			Counter value																											

6.16.10.14 PRESCALER

Address offset: 0x508

12 bit prescaler for COUNTER frequency (32768/(PRESCALER+1)). Must be written when RTC is stopped

Bit number	31 30 29 28 27 26 25 24 23 22 21 20 19 18 17 16 15 14 13 12 11 10 9 8 7 6 5 4 3 2 1 0																														
ID																													A A		
Reset 0x00000000	0 0																														
ID	Acce Field	Value ID	Value	Description																											
A	RW PRESCALER			Prescaler value																											

6.16.10.15 CC[n] (n=0..3)

Address offset: 0x540 + (n × 0x4)

Compare register n

Bit number	31	30	29	28	27	26	25	24	23	22	21	20	19	18	17	16	15	14	13	12	11	10	9	8	7	6	5	4	3	2	1	0
ID										A	A	A	A	A	A	A	A	A	A	A	A	A	A	A	A	A	A	A	A	A	A	A
Reset 0x00000000	0	0	0	0	0	0	0	0	0	0	0	0	0	0	0	0	0	0	0	0	0	0	0	0	0	0	0	0	0	0	0	0
ID	Acce	Field	Value	ID	Value	Description																										
A	RW	COMPARE				Compare value																										

6.16.11 Electrical specification

6.17 SAADC — Successive approximation analog-to-digital converter

The ADC is a differential successive approximation register (SAR) analog-to-digital converter.

Listed here are the main features of SAADC:

- 8/10/12-bit resolution, 14-bit resolution with oversampling
- Up to eight input channels
 - One channel per single-ended input and two channels per differential input
 - Scan mode can be configured with both single-ended channels and differential channels.
- Full scale input range (0 to VDD)
- Sampling triggered via a task from software or a PPI channel for full flexibility on sample frequency source from low power 32.768kHz RTC or more accurate 1/16MHz Timers
- One-shot conversion mode to sample a single channel
- Scan mode to sample a series of channels in sequence. Sample delay between channels is $t_{ack} + t_{conv}$ which may vary between channels according to user configuration of t_{ack} .
- Support for direct sample transfer to RAM using EasyDMA
- Interrupts on single sample and full buffer events
- Samples stored as 16-bit 2's complement values for differential and single-ended sampling
- Continuous sampling without the need of an external timer
- Internal resistor string
- Limit checking on the fly

6.17.1 Shared resources

The ADC can coexist with COMP and other peripherals using one of AIN0–AIN7, provided these are assigned to different pins.

It is not recommended to select the same analog input pin for both modules.

6.17.2 Overview

The ADC supports up to eight external analog input channels, depending on package variant. It can be operated in a one-shot mode with sampling under software control, or a continuous conversion mode with a programmable sampling rate.

The analog inputs can be configured as eight single-ended inputs, four differential inputs or a combination of these. Each channel can be configured to select AIN0 to AIN7 pins, or the VDD pin. Channels can be

sampled individually in one-shot or continuous sampling modes, or, using scan mode, multiple channels can be sampled in sequence. Channels can also be oversampled to improve noise performance.

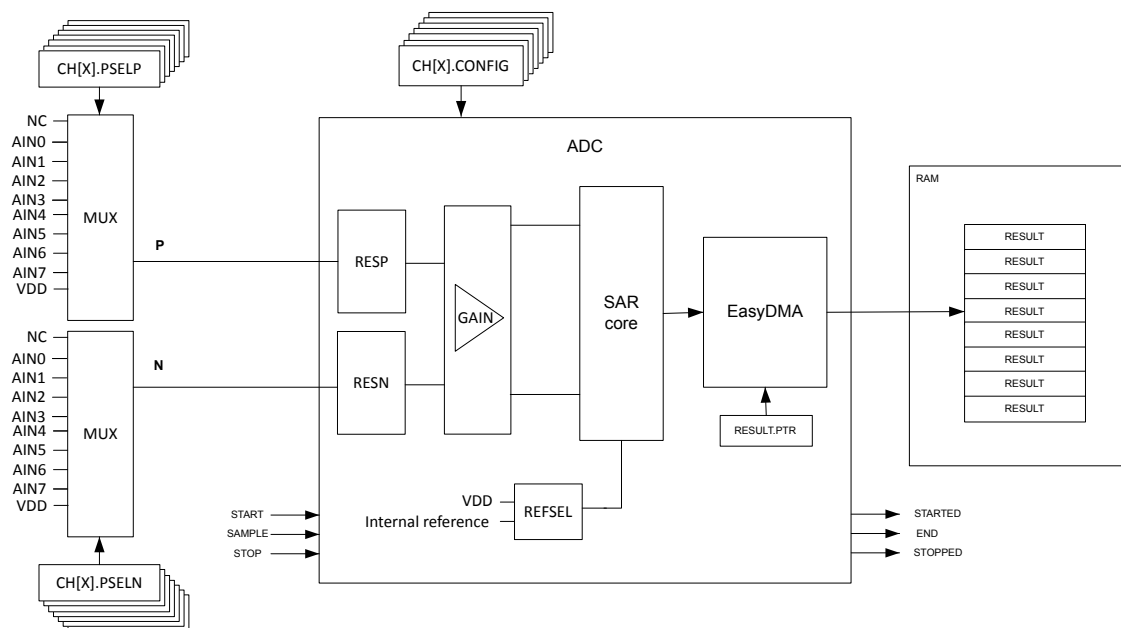

Figure 90: Simplified ADC block diagram

Internally, the ADC is always a differential analog-to-digital converter, but by default it is configured with single-ended input in the MODE field of the CH[n].CONFIG register. In single-ended mode, the negative input will be shorted to ground internally.

The assumption in single-ended mode is that the internal ground of the ADC is the same as the external ground that the measured voltage is referred to. The ADC is thus sensitive to ground bounce on the PCB in single-ended mode. If this is a concern we recommend using differential measurement.

6.17.3 Digital output

The output result of the ADC depends on the settings in the CH[n].CONFIG and RESOLUTION registers as follows:

$$\text{RESULT} = [V(P) - V(N)] * \text{GAIN}/\text{REFERENCE} * 2^{(\text{RESOLUTION} - m)}$$

where

V(P)

is the voltage at input P

V(N)

is the voltage at input N

GAIN

is the selected gain setting

REFERENCE

is the selected reference voltage

and $m=0$ if CONFIG.MODE=SE, or $m=1$ if CONFIG.MODE=Diff.

The result generated by the ADC will deviate from the expected due DC errors like offset, gain, differential non-linearity (DNL), and integral non-linearity (INL). See [Electrical specification](#) for details on these parameters. The result can also vary due to AC errors like non-linearities in the GAIN block, settling errors

due to high source impedance and sampling jitter. For battery measurement the DC errors are most noticeable.

The ADC has a wide selection of gains controlled in the GAIN field of the CH[n].CONFIG register. If CH[n].CONFIG.REFSEL=0, the input range of the ADC core is nominally ± 0.6 V differential and the input must be scaled accordingly.

The ADC has a temperature dependent offset. If the ADC is to operate over a large temperature range, we recommend running CALIBRATEOFFSET at regular intervals, a CALIBRATEDONE event will be fired when the calibration is complete

6.17.4 Analog inputs and channels

Up to eight analog input channels, CH[n](n=0..7), can be configured.

See [Shared resources](#) on page 230 for shared input with comparators.

Any one of the available channels can be enabled for the ADC to operate in one-shot mode. If more than one CH[n] is configured, the ADC enters scan mode.

An analog input is selected as a positive converter input if CH[n].PSELP is set, setting CH[n].PSELP also enables the particular channel.

An analog input is selected as a negative converter input if CH[n].PSELN is set. The CH[n].PSELN register will have no effect unless differential mode is enabled, see MODE field in CH[n].CONFIG register.

If more than one of the CH[n].PSELP registers is set, the device enters scan mode. Input selections in scan mode are controlled by the CH[n].PSELP and CH[n].PSELN registers, where CH[n].PSELN is only used if the particular scan channel is specified as differential, see MODE field in CH[n].CONFIG register.

Important: Channels selected for COMP cannot be used at the same time for ADC sampling, though channels not selected for use by these blocks can be used by the ADC.

Channel input	Source	Connectivity
CH[n].PSELP	AIN0...AIN7	Yes(any)
CH[n].PSELN	VDD	Yes
CH[n].PSELN	AIN0...AIN7	Yes(any)
CH[n].PSELN	VDD	Yes

Table 70: Legal connectivity CH[n] vs. analog input

6.17.5 Operation modes

The ADC input configuration supports one-shot mode, continuous mode and scan mode.

Scan mode and oversampling cannot be combined.

6.17.5.1 One-shot mode

One-shot operation is configured by enabling only one of the available channels defined by CH[n].PSELP, CH[n].PSELN, and CH[n].CONFIG registers.

Upon a SAMPLE task, the ADC starts to sample the input voltage. The CH[n].CONFIG.TACQ controls the acquisition time.

A DONE event signals that one sample has been taken.

In this mode, the RESULTDONE event has the same meaning as DONE when no oversampling takes place. Note that both events may occur before the actual value has been transferred into RAM by EasyDMA. For more information, see [EasyDMA](#) on page 234.

6.17.5.2 Continuous mode

Continuous sampling can be achieved by using the internal timer in the ADC, or triggering the SAMPLE task from one of the general purpose timers through the PPI.

Care shall be taken to ensure that the sample rate fulfils the following criteria, depending on how many channels are active:

$$f_{\text{SAMPLE}} < 1 / [t_{\text{ACQ}} + t_{\text{conv}}]$$

The SAMPLERATE register can be used as a local timer instead of triggering individual SAMPLE tasks. When SAMPLERATE.MODE is set to Timers, it is sufficient to trigger SAMPLE task only once in order to start the SAADC and triggering the STOP task will stop sampling. The SAMPLERATE.CC field controls the sample rate.

The SAMPLERATE timer mode cannot be combined with SCAN mode, and only one channel can be enabled in this mode.

A DONE event signals that one sample has been taken.

In this mode, the RESULTDONE event has the same meaning as DONE when no oversampling takes place. Note that both events may occur before the actual value has been transferred into RAM by EasyDMA.

6.17.5.3 Oversampling

An accumulator in the ADC can be used to average noise on the analog input. In general, oversampling improves the signal-to-noise ratio (SNR). Oversampling, however, does not improve the integral non-linearity (INL), or differential non-linearity (DNL).

Oversampling and scan should not be combined, since oversampling and scan will average over input channels.

The accumulator is controlled in the OVERSAMPLE register. The SAMPLE task must be set $2^{\text{OVERSAMPLE}}$ number of times before the result is written to RAM. This can be achieved by:

- Configuring a fixed sampling rate using the local timer or a general purpose timer and PPI to trigger a SAMPLE task
- Triggering SAMPLE $2^{\text{OVERSAMPLE}}$ times from software
- Enabling BURST mode

CH[n].CONFIG.BURST can be enabled to avoid setting SAMPLE task $2^{\text{OVERSAMPLE}}$ times. With BURST = 1 the ADC will sample the input $2^{\text{OVERSAMPLE}}$ times as fast as it can (actual timing: $<(t_{\text{ACQ}}+t_{\text{CONV}}) \times 2^{\text{OVERSAMPLE}}>$). Thus, for the user it will just appear like the conversion took a bit longer time, but other than that, it is similar to one-shot mode. Scan mode can be combined with BURST=1, if burst is enabled on all channels.

A DONE event signals that one sample has been taken.

In this mode, the RESULTDONE event signals that enough conversions have taken place for an oversampled result to get transferred into RAM. Note that both events may occur before the actual value has been transferred into RAM by EasyDMA.

6.17.5.4 Scan mode

A channel is considered enabled if CH[n].PSEL is set. If more than one channel, CH[n], is enabled, the ADC enters scan mode.

In scan mode, one SAMPLE task will trigger one conversion per enabled channel. The time it takes to sample all channels is:

$$\text{Total time} < \text{Sum}(\text{CH}[x].t_{\text{ACQ}}+t_{\text{CONV}}), x=0..\text{enabled channels}$$

A DONE event signals that one sample has been taken.

In this mode, the RESULTDONE event signals has the same meaning as DONE when no oversampling takes place. Note that both events may occur before the actual values have been transferred into RAM by EasyDMA.

[Example of RAM placement \(even RESULT.MAXCNT\), channels 1, 2 and 5 enabled](#) on page 234 provides an example of results placement in Data RAM, with an even RESULT.MAXCNT. In this example, channels 1, 2 and 5 are enabled, all others are disabled.

	31	16	15	0
RESULT.PTR	CH[2] 1 st result		CH[1] 1 st result	
RESULT.PTR + 4	CH[1] 2 nd result		CH[5] 1 st result	
RESULT.PTR + 8	CH[5] 2 nd result		CH[2] 2 nd result	
	(...)			
RESULT.PTR + 2*(RESULT.MAXCNT - 2)	CH[5] last result		CH[2] last result	

Figure 91: Example of RAM placement (even RESULT.MAXCNT), channels 1, 2 and 5 enabled

[Example of RAM placement \(odd RESULT.MAXCNT\), channels 1, 2 and 5 enabled](#) on page 234 provides an example of results placement in Data RAM, with an odd RESULT.MAXCNT. In this example, channels 1, 2 and 5 are enabled, all others are disabled. The last 32-bit word is populated only with one 16-bit result.

	31	16	15	0
RESULT.PTR	CH[2] 1 st result		CH[1] 1 st result	
RESULT.PTR + 4	CH[1] 2 nd result		CH[5] 1 st result	
RESULT.PTR + 8	CH[5] 2 nd result		CH[2] 2 nd result	
	(...)			
RESULT.PTR + 2*(RESULT.MAXCNT - 1)			CH[5] last result	

Figure 92: Example of RAM placement (odd RESULT.MAXCNT), channels 1, 2 and 5 enabled

6.17.6 EasyDMA

After configuring RESULT.PTR and RESULT.MAXCNT, the ADC resources are started by triggering the START task. The ADC is using EasyDMA to store results in a Result buffer in RAM.

The Result buffer is located at the address specified in the RESULT.PTR register. The RESULT.PTR register is double-buffered and it can be updated and prepared for the next START task immediately after the STARTED event is generated. The size of the Result buffer is specified in the RESULT.MAXCNT register and the ADC will generate an END event when it has filled up the Result buffer, see [ADC](#) on page 235. Results are stored in little-endian byte order in Data RAM. Every sample will be sign extended to 16 bit before stored in the Result buffer.

The ADC is stopped by triggering the STOP task. The STOP task will terminate an ongoing sampling. The ADC will generate a STOPPED event when it has stopped. If the ADC is already stopped when the STOP task is triggered, the STOPPED event will still be generated.

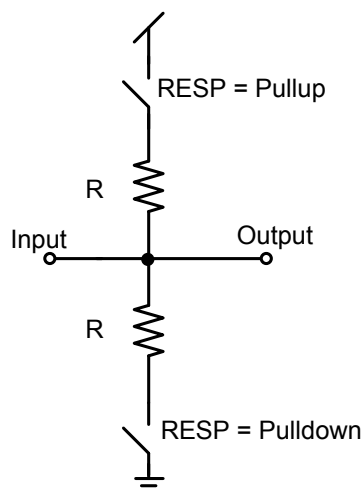

Figure 94: Resistor ladder for positive input (negative input is equivalent, using RESN instead of RESP)

6.17.8 Reference

The ADC can use two different references, controlled in the REFSEL field of the CH[n].CONFIG register.

These are:

- Internal reference
- VDD as reference

The internal reference results in an input range of ± 0.6 V on the ADC core. VDD as reference results in an input range of $\pm VDD/4$ on the ADC core. The gain block can be used to change the effective input range of the ADC.

$$\text{Input range} = (+- 0.6 \text{ V or } +-VDD/4) / \text{Gain}$$

For example, choosing VDD as reference, single ended input (grounded negative input), and a gain of 1/4 the input range will be:

$$\text{Input range} = (VDD/4) / (1/4) = VDD$$

With internal reference, single ended input (grounded negative input), and a gain of 1/6 the input range will be:

$$\text{Input range} = (0.6 \text{ V}) / (1/6) = 3.6 \text{ V}$$

The AIN0-AIN7 inputs cannot exceed VDD, or be lower than VSS.

6.17.9 Acquisition time

To sample the input voltage, the ADC connects a capacitor to the input.

For illustration, see [Simplified ADC sample network](#) on page 237. The acquisition time indicates how long the capacitor is connected, see TACQ field in CH[n].CONFIG register. The required acquisition time depends on the source (R_{source}) resistance. For high source resistance the acquisition time should be increased, see [Acquisition time](#) on page 237.

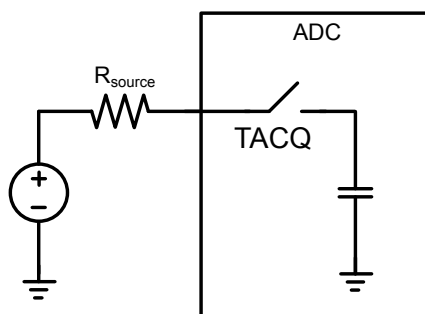

Figure 95: Simplified ADC sample network

TACQ [μs]	Maximum source resistance [kOhm]
3	10
5	40
10	100
15	200
20	400
40	800

Table 71: Acquisition time

6.17.10 Limits event monitoring

A channel can be event monitored by configuring limit register CH[n].LIMIT.

If the conversion result is higher than the defined high limit, or lower than the defined low limit, the appropriate event will get fired.

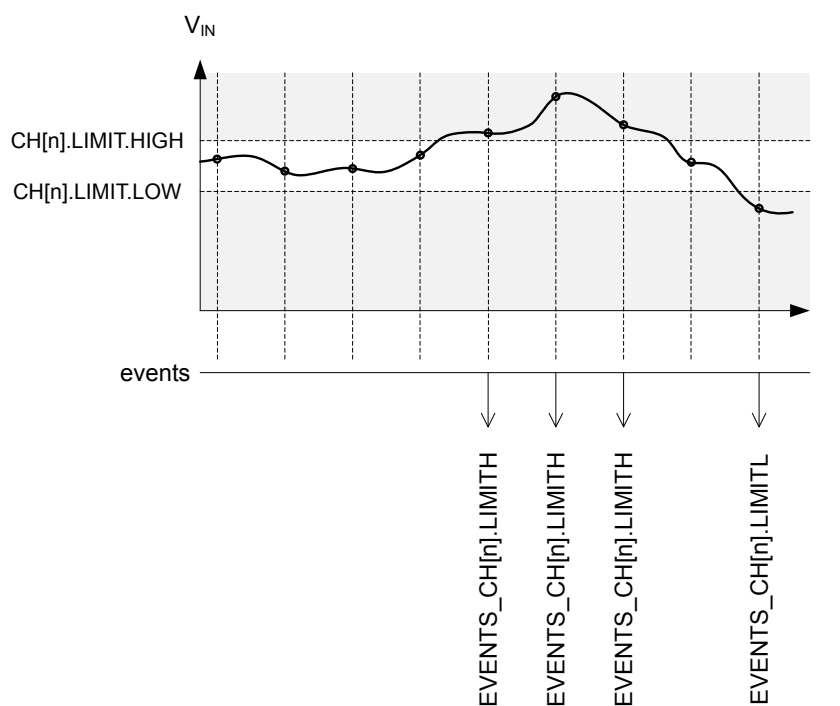

Figure 96: Example of limits monitoring on channel 'n'

Note that when setting the limits, CH[n].LIMIT.HIGH shall always be higher than or equal to CH[n].LIMIT.LOW . In other words, an event can be fired only when the input signal has been sampled outside of the defined limits. It is not possible to fire an event when the input signal is inside a defined range by swapping high and low limits.

The comparison to limits always takes place, there is no need to enable it. If comparison is not required on a channel, the software shall simply ignore the related events. In that situation, the value of the limits registers is irrelevant, so it does not matter if CH[n].LIMIT.LOW is lower than CH[n].LIMIT.HIGH or not.

6.17.11 Registers

Base address	Peripheral	Instance	Description	Configuration
0x40007000	SAADC	SAADC	Analog-to-digital converter	

Table 72: Instances

Register	Offset	Description
TASKS_START	0x000	Start the ADC and prepare the result buffer in RAM
TASKS_SAMPLE	0x004	Take one ADC sample, if scan is enabled all channels are sampled
TASKS_STOP	0x008	Stop the ADC and terminate any on-going conversion
TASKS_CALIBRATEOFFSET	0x00C	Starts offset auto-calibration
EVENTS_STARTED	0x100	The ADC has started
EVENTS_END	0x104	The ADC has filled up the Result buffer
EVENTS_DONE	0x108	A conversion task has been completed. Depending on the mode, multiple conversions might be needed for a result to be transferred to RAM.
EVENTS_RESULTDONE	0x10C	A result is ready to get transferred to RAM.
EVENTS_CALIBRATEDONE	0x110	Calibration is complete
EVENTS_STOPPED	0x114	The ADC has stopped
EVENTS_CH[0].LIMITH	0x118	Last results is equal or above CH[0].LIMIT.HIGH
EVENTS_CH[0].LIMITL	0x11C	Last results is equal or below CH[0].LIMIT.LOW
EVENTS_CH[1].LIMITH	0x120	Last results is equal or above CH[1].LIMIT.HIGH
EVENTS_CH[1].LIMITL	0x124	Last results is equal or below CH[1].LIMIT.LOW
EVENTS_CH[2].LIMITH	0x128	Last results is equal or above CH[2].LIMIT.HIGH
EVENTS_CH[2].LIMITL	0x12C	Last results is equal or below CH[2].LIMIT.LOW
EVENTS_CH[3].LIMITH	0x130	Last results is equal or above CH[3].LIMIT.HIGH
EVENTS_CH[3].LIMITL	0x134	Last results is equal or below CH[3].LIMIT.LOW
EVENTS_CH[4].LIMITH	0x138	Last results is equal or above CH[4].LIMIT.HIGH
EVENTS_CH[4].LIMITL	0x13C	Last results is equal or below CH[4].LIMIT.LOW
EVENTS_CH[5].LIMITH	0x140	Last results is equal or above CH[5].LIMIT.HIGH
EVENTS_CH[5].LIMITL	0x144	Last results is equal or below CH[5].LIMIT.LOW
EVENTS_CH[6].LIMITH	0x148	Last results is equal or above CH[6].LIMIT.HIGH
EVENTS_CH[6].LIMITL	0x14C	Last results is equal or below CH[6].LIMIT.LOW
EVENTS_CH[7].LIMITH	0x150	Last results is equal or above CH[7].LIMIT.HIGH
EVENTS_CH[7].LIMITL	0x154	Last results is equal or below CH[7].LIMIT.LOW
INTEN	0x300	Enable or disable interrupt
INTENSET	0x304	Enable interrupt
INTENCLR	0x308	Disable interrupt
STATUS	0x400	Status
ENABLE	0x500	Enable or disable ADC
CH[0].PSEL	0x510	Input positive pin selection for CH[0]
CH[0].PSELN	0x514	Input negative pin selection for CH[0]
CH[0].CONFIG	0x518	Input configuration for CH[0]
CH[0].LIMIT	0x51C	High/low limits for event monitoring a channel
CH[1].PSEL	0x520	Input positive pin selection for CH[1]

Register	Offset	Description
CH[1].PSELN	0x524	Input negative pin selection for CH[1]
CH[1].CONFIG	0x528	Input configuration for CH[1]
CH[1].LIMIT	0x52C	High/low limits for event monitoring a channel
CH[2].PSELN	0x530	Input positive pin selection for CH[2]
CH[2].PSELN	0x534	Input negative pin selection for CH[2]
CH[2].CONFIG	0x538	Input configuration for CH[2]
CH[2].LIMIT	0x53C	High/low limits for event monitoring a channel
CH[3].PSELN	0x540	Input positive pin selection for CH[3]
CH[3].PSELN	0x544	Input negative pin selection for CH[3]
CH[3].CONFIG	0x548	Input configuration for CH[3]
CH[3].LIMIT	0x54C	High/low limits for event monitoring a channel
CH[4].PSELN	0x550	Input positive pin selection for CH[4]
CH[4].PSELN	0x554	Input negative pin selection for CH[4]
CH[4].CONFIG	0x558	Input configuration for CH[4]
CH[4].LIMIT	0x55C	High/low limits for event monitoring a channel
CH[5].PSELN	0x560	Input positive pin selection for CH[5]
CH[5].PSELN	0x564	Input negative pin selection for CH[5]
CH[5].CONFIG	0x568	Input configuration for CH[5]
CH[5].LIMIT	0x56C	High/low limits for event monitoring a channel
CH[6].PSELN	0x570	Input positive pin selection for CH[6]
CH[6].PSELN	0x574	Input negative pin selection for CH[6]
CH[6].CONFIG	0x578	Input configuration for CH[6]
CH[6].LIMIT	0x57C	High/low limits for event monitoring a channel
CH[7].PSELN	0x580	Input positive pin selection for CH[7]
CH[7].PSELN	0x584	Input negative pin selection for CH[7]
CH[7].CONFIG	0x588	Input configuration for CH[7]
CH[7].LIMIT	0x58C	High/low limits for event monitoring a channel
RESOLUTION	0x5F0	Resolution configuration
OVERSAMPLE	0x5F4	Oversampling configuration. OVERSAMPLE should not be combined with SCAN. The RESOLUTION is applied before averaging, thus for high OVERSAMPLE a higher RESOLUTION should be used.
SAMPLERATE	0x5F8	Controls normal or continuous sample rate
RESULT.PTR	0x62C	Data pointer
RESULT.MAXCNT	0x630	Maximum number of buffer words to transfer
RESULT.AMOUNT	0x634	Number of buffer words transferred since last START

Table 73: Register overview

6.17.11.1 TASKS_START

Address offset: 0x000

Start the ADC and prepare the result buffer in RAM

Bit number	31 30 29 28 27 26 25 24 23 22 21 20 19 18 17 16 15 14 13 12 11 10 9 8 7 6 5 4 3 2 1 0																														
ID	A																														
Reset	0x00000000																														
ID	Acc	Field	Value	ID	Value	Description																									
A	W	TASKS_START	Trigger	1		Start the ADC and prepare the result buffer in RAM Trigger task																									

6.17.11.2 TASKS_SAMPLE

Address offset: 0x004

Take one ADC sample, if scan is enabled all channels are sampled

Bit number	31 30 29 28 27 26 25 24 23 22 21 20 19 18 17 16 15 14 13 12 11 10 9 8 7 6 5 4 3 2 1 0																														
ID	A																														
Reset 0x00000000	0 0																														
ID	Acce Field	Value ID	Value	Description																											
A	W TASKS_SAMPLE			Take one ADC sample, if scan is enabled all channels are sampled																											
		Trigger	1	Trigger task																											

6.17.11.3 TASKS_STOP

Address offset: 0x008

Stop the ADC and terminate any on-going conversion

Bit number	31 30 29 28 27 26 25 24 23 22 21 20 19 18 17 16 15 14 13 12 11 10 9 8 7 6 5 4 3 2 1 0																														
ID	A																														
Reset 0x00000000	0 0																														
ID	Acce Field	Value ID	Value	Description																											
A	W TASKS_STOP			Stop the ADC and terminate any on-going conversion																											
		Trigger	1	Trigger task																											

6.17.11.4 TASKS_CALIBRATEOFFSET

Address offset: 0x00C

Starts offset auto-calibration

Bit number	31 30 29 28 27 26 25 24 23 22 21 20 19 18 17 16 15 14 13 12 11 10 9 8 7 6 5 4 3 2 1 0																														
ID	A																														
Reset 0x00000000	0 0																														
ID	Acce Field	Value ID	Value	Description																											
A	W TASKS_CALIBRATEOFFSET			Starts offset auto-calibration																											
		Trigger	1	Trigger task																											

6.17.11.5 EVENTS_STARTED

Address offset: 0x100

The ADC has started

Bit number	31 30 29 28 27 26 25 24 23 22 21 20 19 18 17 16 15 14 13 12 11 10 9 8 7 6 5 4 3 2 1 0																														
ID	A																														
Reset 0x00000000	0 0																														
ID	Acce Field	Value ID	Value	Description																											
A	RW EVENTS_STARTED			The ADC has started																											
		NotGenerated	0	Event not generated																											
		Generated	1	Event generated																											

6.17.11.6 EVENTS_END

Address offset: 0x104

The ADC has filled up the Result buffer

Bit number	31	30	29	28	27	26	25	24	23	22	21	20	19	18	17	16	15	14	13	12	11	10	9	8	7	6	5	4	3	2	1	0
ID																																A
Reset	0x00000000																															
	0 0																															
ID	Acce Field	Value ID	Value	Description																												
A	RW	EVENTS_END		The ADC has filled up the Result buffer																												
		NotGenerated	0	Event not generated																												
		Generated	1	Event generated																												

6.17.11.7 EVENTS_DONE

Address offset: 0x108

A conversion task has been completed. Depending on the mode, multiple conversions might be needed for a result to be transferred to RAM.

Bit number	31	30	29	28	27	26	25	24	23	22	21	20	19	18	17	16	15	14	13	12	11	10	9	8	7	6	5	4	3	2	1	0
ID																																A
Reset	0x00000000																															
	0 0																															
ID	Acce Field	Value ID	Value	Description																												
A	RW	EVENTS_DONE		A conversion task has been completed. Depending on the mode, multiple conversions might be needed for a result to be transferred to RAM.																												
		NotGenerated	0	Event not generated																												
		Generated	1	Event generated																												

6.17.11.8 EVENTS_RESULTDONE

Address offset: 0x10C

A result is ready to get transferred to RAM.

Bit number	31	30	29	28	27	26	25	24	23	22	21	20	19	18	17	16	15	14	13	12	11	10	9	8	7	6	5	4	3	2	1	0
ID																																A
Reset	0x00000000																															
	0 0																															
ID	Acce Field	Value ID	Value	Description																												
A	RW	EVENTS_RESULTDONE		A result is ready to get transferred to RAM.																												
		NotGenerated	0	Event not generated																												
		Generated	1	Event generated																												

6.17.11.9 EVENTS_CALIBRATEDONE

Address offset: 0x110

Calibration is complete

Bit number	31	30	29	28	27	26	25	24	23	22	21	20	19	18	17	16	15	14	13	12	11	10	9	8	7	6	5	4	3	2	1	0
ID																																A
Reset	0x00000000																															
	0 0																															
ID	Acce Field	Value ID	Value	Description																												
A	RW	EVENTS_CALIBRATEDONE		Calibration is complete																												
		NotGenerated	0	Event not generated																												
		Generated	1	Event generated																												

6.17.11.10 EVENTS_STOPPED

Address offset: 0x114

The ADC has stopped

Bit number	31 30 29 28 27 26 25 24 23 22 21 20 19 18 17 16 15 14 13 12 11 10 9 8 7 6 5 4 3 2 1 0																														
ID	A																														
Reset 0x00000000	0 0																														
ID	Acce Field	Value ID	Value	Description																											
A	RW	EVENTS_STOPPED		The ADC has stopped																											
		NotGenerated	0	Event not generated																											
		Generated	1	Event generated																											

6.17.11.11 EVENTS_CH[n].LIMITH (n=0..7)

Address offset: 0x118 + (n × 0x8)

Last results is equal or above CH[n].LIMIT.HIGH

Bit number	31 30 29 28 27 26 25 24 23 22 21 20 19 18 17 16 15 14 13 12 11 10 9 8 7 6 5 4 3 2 1 0																														
ID	A																														
Reset 0x00000000	0 0																														
ID	Acce Field	Value ID	Value	Description																											
A	RW	LIMITH		Last results is equal or above CH[n].LIMIT.HIGH																											
		NotGenerated	0	Event not generated																											
		Generated	1	Event generated																											

6.17.11.12 EVENTS_CH[n].LIMITL (n=0..7)

Address offset: 0x11C + (n × 0x8)

Last results is equal or below CH[n].LIMIT.LOW

Bit number	31 30 29 28 27 26 25 24 23 22 21 20 19 18 17 16 15 14 13 12 11 10 9 8 7 6 5 4 3 2 1 0																														
ID	A																														
Reset 0x00000000	0 0																														
ID	Acce Field	Value ID	Value	Description																											
A	RW	LIMITL		Last results is equal or below CH[n].LIMIT.LOW																											
		NotGenerated	0	Event not generated																											
		Generated	1	Event generated																											

6.17.11.13 INTEN

Address offset: 0x300

Enable or disable interrupt

Bit number	31 30 29 28 27 26 25 24 23 22 21 20 19 18 17 16 15 14 13 12 11 10 9 8 7 6 5 4 3 2 1 0																														
ID																V U T S R Q P O N M L K J I H G F E D C B A															
Reset 0x00000000	0 0																														
ID	Acce Field	Value ID	Value	Description																											
A	RW	STARTED		Enable or disable interrupt for event STARTED																											
		Disabled	0	Disable																											
		Enabled	1	Enable																											

Bit number		31 30 29 28 27 26 25 24 23 22 21 20 19 18 17 16 15 14 13 12 11 10 9 8 7 6 5 4 3 2 1 0																											
ID		V U T S R Q P O N M L K J I H G F E D C B A																											
Reset 0x00000000		0 0																											
ID	Acce Field	Value ID	Value	Description																									
B	RW END	Disabled	0	Enable or disable interrupt for event END																									
		Enabled	1	Disable																									
C	RW DONE	Disabled	0	Enable or disable interrupt for event DONE																									
		Enabled	1	Disable																									
D	RW RESULTDONE	Disabled	0	Enable or disable interrupt for event RESULTDONE																									
		Enabled	1	Disable																									
E	RW CALIBRATEDONE	Disabled	0	Enable or disable interrupt for event CALIBRATEDONE																									
		Enabled	1	Disable																									
F	RW STOPPED	Disabled	0	Enable or disable interrupt for event STOPPED																									
		Enabled	1	Disable																									
G	RW CHOLIMITH	Disabled	0	Enable or disable interrupt for event CHOLIMITH																									
		Enabled	1	Disable																									
H	RW CHOLIMITL	Disabled	0	Enable or disable interrupt for event CHOLIMITL																									
		Enabled	1	Disable																									
I	RW CH1LIMITH	Disabled	0	Enable or disable interrupt for event CH1LIMITH																									
		Enabled	1	Disable																									
J	RW CH1LIMITL	Disabled	0	Enable or disable interrupt for event CH1LIMITL																									
		Enabled	1	Disable																									
K	RW CH2LIMITH	Disabled	0	Enable or disable interrupt for event CH2LIMITH																									
		Enabled	1	Disable																									
L	RW CH2LIMITL	Disabled	0	Enable or disable interrupt for event CH2LIMITL																									
		Enabled	1	Disable																									
M	RW CH3LIMITH	Disabled	0	Enable or disable interrupt for event CH3LIMITH																									
		Enabled	1	Disable																									
N	RW CH3LIMITL	Disabled	0	Enable or disable interrupt for event CH3LIMITL																									
		Enabled	1	Disable																									
O	RW CH4LIMITH	Disabled	0	Enable or disable interrupt for event CH4LIMITH																									
		Enabled	1	Disable																									
P	RW CH4LIMITL	Disabled	0	Enable or disable interrupt for event CH4LIMITL																									
		Enabled	1	Disable																									
Q	RW CH5LIMITH	Disabled	0	Enable or disable interrupt for event CH5LIMITH																									
		Enabled	1	Disable																									
R	RW CH5LIMITL	Disabled	0	Enable or disable interrupt for event CH5LIMITL																									
		Enabled	1	Disable																									

Bit number		31 30 29 28 27 26 25 24 23 22 21 20 19 18 17 16 15 14 13 12 11 10 9 8 7 6 5 4 3 2 1 0																											
ID		V U T S R Q P O N M L K J I H G F E D C B A																											
Reset 0x00000000		0 0																											
ID	Acce Field	Value ID	Value	Description																									
S	RW CH6LIMITH	Enabled	1	Enable																									
		Disabled	0	Disable																									
		Enabled	1	Enable																									
T	RW CH6LIMITL	Disabled	0	Disable																									
		Enabled	1	Enable																									
		Enabled	1	Enable																									
U	RW CH7LIMITH	Disabled	0	Disable																									
		Enabled	1	Enable																									
		Enabled	1	Enable																									
V	RW CH7LIMITL	Disabled	0	Disable																									
		Enabled	1	Enable																									
		Enabled	1	Enable																									

6.17.11.14 INTENSET

Address offset: 0x304

Enable interrupt

Bit number		31 30 29 28 27 26 25 24 23 22 21 20 19 18 17 16 15 14 13 12 11 10 9 8 7 6 5 4 3 2 1 0																											
ID		V U T S R Q P O N M L K J I H G F E D C B A																											
Reset 0x00000000		0 0																											
ID	Acce Field	Value ID	Value	Description																									
A	RW STARTED	Set	1	Write '1' to enable interrupt for event STARTED																									
		Disabled	0	Read: Disabled																									
		Enabled	1	Read: Enabled																									
B	RW END	Set	1	Write '1' to enable interrupt for event END																									
		Disabled	0	Read: Disabled																									
		Enabled	1	Read: Enabled																									
C	RW DONE	Set	1	Write '1' to enable interrupt for event DONE																									
		Disabled	0	Read: Disabled																									
		Enabled	1	Read: Enabled																									
D	RW RESULTDONE	Set	1	Write '1' to enable interrupt for event RESULTDONE																									
		Disabled	0	Read: Disabled																									
		Enabled	1	Read: Enabled																									
E	RW CALIBRATEDONE	Set	1	Write '1' to enable interrupt for event CALIBRATEDONE																									
		Disabled	0	Read: Disabled																									
		Enabled	1	Read: Enabled																									
F	RW STOPPED	Set	1	Write '1' to enable interrupt for event STOPPED																									
		Disabled	0	Read: Disabled																									
		Enabled	1	Read: Enabled																									
G	RW CH0LIMITH	Set	1	Write '1' to enable interrupt for event CH0LIMITH																									
		Set	1	Enable																									

Bit number		31 30 29 28 27 26 25 24 23 22 21 20 19 18 17 16 15 14 13 12 11 10 9 8 7 6 5 4 3 2 1 0																											
ID		V U T S R Q P O N M L K J I H G F E D C B A																											
Reset 0x00000000		0 0																											
ID	Acce Field	Value ID	Value	Description																									
		Disabled	0	Read: Disabled																									
		Enabled	1	Read: Enabled																									
H	RW CH0LIMITL			Write '1' to enable interrupt for event CH0LIMITL																									
		Set	1	Enable																									
		Disabled	0	Read: Disabled																									
		Enabled	1	Read: Enabled																									
I	RW CH1LIMITH			Write '1' to enable interrupt for event CH1LIMITH																									
		Set	1	Enable																									
		Disabled	0	Read: Disabled																									
		Enabled	1	Read: Enabled																									
J	RW CH1LIMITL			Write '1' to enable interrupt for event CH1LIMITL																									
		Set	1	Enable																									
		Disabled	0	Read: Disabled																									
		Enabled	1	Read: Enabled																									
K	RW CH2LIMITH			Write '1' to enable interrupt for event CH2LIMITH																									
		Set	1	Enable																									
		Disabled	0	Read: Disabled																									
		Enabled	1	Read: Enabled																									
L	RW CH2LIMITL			Write '1' to enable interrupt for event CH2LIMITL																									
		Set	1	Enable																									
		Disabled	0	Read: Disabled																									
		Enabled	1	Read: Enabled																									
M	RW CH3LIMITH			Write '1' to enable interrupt for event CH3LIMITH																									
		Set	1	Enable																									
		Disabled	0	Read: Disabled																									
		Enabled	1	Read: Enabled																									
N	RW CH3LIMITL			Write '1' to enable interrupt for event CH3LIMITL																									
		Set	1	Enable																									
		Disabled	0	Read: Disabled																									
		Enabled	1	Read: Enabled																									
O	RW CH4LIMITH			Write '1' to enable interrupt for event CH4LIMITH																									
		Set	1	Enable																									
		Disabled	0	Read: Disabled																									
		Enabled	1	Read: Enabled																									
P	RW CH4LIMITL			Write '1' to enable interrupt for event CH4LIMITL																									
		Set	1	Enable																									
		Disabled	0	Read: Disabled																									
		Enabled	1	Read: Enabled																									
Q	RW CH5LIMITH			Write '1' to enable interrupt for event CH5LIMITH																									
		Set	1	Enable																									
		Disabled	0	Read: Disabled																									
		Enabled	1	Read: Enabled																									
R	RW CH5LIMITL			Write '1' to enable interrupt for event CH5LIMITL																									
		Set	1	Enable																									
		Disabled	0	Read: Disabled																									
		Enabled	1	Read: Enabled																									
S	RW CH6LIMITH			Write '1' to enable interrupt for event CH6LIMITH																									
		Set	1	Enable																									
		Disabled	0	Read: Disabled																									
		Enabled	1	Read: Enabled																									

Bit number	31 30 29 28 27 26 25 24 23 22 21 20 19 18 17 16 15 14 13 12 11 10 9 8 7 6 5 4 3 2 1 0																														
ID	V U T S R Q P O N M L K J I H G F E D C B A																														
Reset 0x00000000	0 0																														
ID	Acce Field	Value ID	Value	Description																											
T	RW CH6LIMITL			Write '1' to enable interrupt for event CH6LIMITL																											
		Set	1	Enable																											
		Disabled	0	Read: Disabled																											
U	RW CH7LIMITH	Enabled	1	Read: Enabled																											
		Set	1	Enable																											
		Disabled	0	Read: Disabled																											
V	RW CH7LIMITL	Enabled	1	Read: Enabled																											
		Set	1	Enable																											
		Disabled	0	Read: Disabled																											

6.17.11.15 INTENCLR

Address offset: 0x308

Disable interrupt

Bit number	31 30 29 28 27 26 25 24 23 22 21 20 19 18 17 16 15 14 13 12 11 10 9 8 7 6 5 4 3 2 1 0																														
ID	V U T S R Q P O N M L K J I H G F E D C B A																														
Reset 0x00000000	0 0																														
ID	Acce Field	Value ID	Value	Description																											
A	RW STARTED			Write '1' to disable interrupt for event STARTED																											
		Clear	1	Disable																											
		Disabled	0	Read: Disabled																											
B	RW END	Enabled	1	Read: Enabled																											
		Clear	1	Disable																											
		Disabled	0	Read: Disabled																											
C	RW DONE	Enabled	1	Read: Enabled																											
		Clear	1	Disable																											
		Disabled	0	Read: Disabled																											
D	RW RESULTDONE	Enabled	1	Read: Enabled																											
		Clear	1	Disable																											
		Disabled	0	Read: Disabled																											
E	RW CALIBRATEDONE	Enabled	1	Read: Enabled																											
		Clear	1	Disable																											
		Disabled	0	Read: Disabled																											
F	RW STOPPED	Enabled	1	Read: Enabled																											
		Clear	1	Disable																											
		Disabled	0	Read: Disabled																											
G	RW CH0LIMITH	Enabled	1	Read: Enabled																											
		Clear	1	Disable																											
		Disabled	0	Read: Disabled																											

Bit number		31 30 29 28 27 26 25 24 23 22 21 20 19 18 17 16 15 14 13 12 11 10 9 8 7 6 5 4 3 2 1 0																											
ID		V U T S R Q P O N M L K J I H G F E D C B A																											
Reset 0x00000000		0 0																											
ID	Acce Field	Value ID	Value	Description																									
		Enabled	1	Read: Enabled																									
H	RW CH0LIMITL			Write '1' to disable interrupt for event CH0LIMITL																									
		Clear	1	Disable																									
		Disabled	0	Read: Disabled																									
		Enabled	1	Read: Enabled																									
I	RW CH1LIMITH			Write '1' to disable interrupt for event CH1LIMITH																									
		Clear	1	Disable																									
		Disabled	0	Read: Disabled																									
		Enabled	1	Read: Enabled																									
J	RW CH1LIMITL			Write '1' to disable interrupt for event CH1LIMITL																									
		Clear	1	Disable																									
		Disabled	0	Read: Disabled																									
		Enabled	1	Read: Enabled																									
K	RW CH2LIMITH			Write '1' to disable interrupt for event CH2LIMITH																									
		Clear	1	Disable																									
		Disabled	0	Read: Disabled																									
		Enabled	1	Read: Enabled																									
L	RW CH2LIMITL			Write '1' to disable interrupt for event CH2LIMITL																									
		Clear	1	Disable																									
		Disabled	0	Read: Disabled																									
		Enabled	1	Read: Enabled																									
M	RW CH3LIMITH			Write '1' to disable interrupt for event CH3LIMITH																									
		Clear	1	Disable																									
		Disabled	0	Read: Disabled																									
		Enabled	1	Read: Enabled																									
N	RW CH3LIMITL			Write '1' to disable interrupt for event CH3LIMITL																									
		Clear	1	Disable																									
		Disabled	0	Read: Disabled																									
		Enabled	1	Read: Enabled																									
O	RW CH4LIMITH			Write '1' to disable interrupt for event CH4LIMITH																									
		Clear	1	Disable																									
		Disabled	0	Read: Disabled																									
		Enabled	1	Read: Enabled																									
P	RW CH4LIMITL			Write '1' to disable interrupt for event CH4LIMITL																									
		Clear	1	Disable																									
		Disabled	0	Read: Disabled																									
		Enabled	1	Read: Enabled																									
Q	RW CH5LIMITH			Write '1' to disable interrupt for event CH5LIMITH																									
		Clear	1	Disable																									
		Disabled	0	Read: Disabled																									
		Enabled	1	Read: Enabled																									
R	RW CH5LIMITL			Write '1' to disable interrupt for event CH5LIMITL																									
		Clear	1	Disable																									
		Disabled	0	Read: Disabled																									
		Enabled	1	Read: Enabled																									
S	RW CH6LIMITH			Write '1' to disable interrupt for event CH6LIMITH																									
		Clear	1	Disable																									
		Disabled	0	Read: Disabled																									
		Enabled	1	Read: Enabled																									
T	RW CH6LIMITL			Write '1' to disable interrupt for event CH6LIMITL																									

Bit number	31 30 29 28 27 26 25 24 23 22 21 20 19 18 17 16 15 14 13 12 11 10 9 8 7 6 5 4 3 2 1 0																															
ID	V U T S R Q P O N M L K J I H G F E D C B A																															
Reset 0x00000000		0 0																														
ID	Acce Field	Value ID	Value	Description																												
		Clear	1	Disable																												
		Disabled	0	Read: Disabled																												
		Enabled	1	Read: Enabled																												
U	RW CH7LIMITH			Write '1' to disable interrupt for event CH7LIMITH																												
		Clear	1	Disable																												
		Disabled	0	Read: Disabled																												
		Enabled	1	Read: Enabled																												
V	RW CH7LIMITL			Write '1' to disable interrupt for event CH7LIMITL																												
		Clear	1	Disable																												
		Disabled	0	Read: Disabled																												
		Enabled	1	Read: Enabled																												

6.17.11.16 STATUS

Address offset: 0x400

Status

Bit number	31 30 29 28 27 26 25 24 23 22 21 20 19 18 17 16 15 14 13 12 11 10 9 8 7 6 5 4 3 2 1 0																															
ID																																A
Reset 0x00000000		0 0																														
ID	Acce Field	Value ID	Value	Description																												
A	R STATUS			Status																												
		Ready	0	ADC is ready. No on-going conversion.																												
		Busy	1	ADC is busy. Conversion in progress.																												

6.17.11.17 ENABLE

Address offset: 0x500

Enable or disable ADC

Bit number	31 30 29 28 27 26 25 24 23 22 21 20 19 18 17 16 15 14 13 12 11 10 9 8 7 6 5 4 3 2 1 0																															
ID																																A
Reset 0x00000000		0 0																														
ID	Acce Field	Value ID	Value	Description																												
A	RW ENABLE			Enable or disable ADC																												
		Disabled	0	Disable ADC																												
		Enabled	1	Enable ADC																												
				When enabled, the ADC will acquire access to the analog input pins specified in the CH[n].PSELP and CH[n].PSELN registers.																												

6.17.11.18 CH[n].PSELP (n=0..7)

Address offset: 0x510 + (n × 0x10)

Input positive pin selection for CH[n]

Bit number	31 30 29 28 27 26 25 24 23 22 21 20 19 18 17 16 15 14 13 12 11 10 9 8 7 6 5 4 3 2 1 0																																		
ID																															A	A	A	A	A
Reset 0x00000000	0 0																																		
ID	Acce	Field	Value ID	Value	Description																														
A	RW	PSELP			Analog positive input channel																														
			NC	0	Not connected																														
			AnalogInput0	1	AIN0																														
			AnalogInput1	2	AIN1																														
			AnalogInput2	3	AIN2																														
			AnalogInput3	4	AIN3																														
			AnalogInput4	5	AIN4																														
			AnalogInput5	6	AIN5																														
			AnalogInput6	7	AIN6																														
			AnalogInput7	8	AIN7																														
			VDD	9	VDD																														

6.17.11.19 CH[n].PSELN (n=0..7)

Address offset: $0x514 + (n \times 0x10)$

Input negative pin selection for CH[n]

Bit number	31 30 29 28 27 26 25 24 23 22 21 20 19 18 17 16 15 14 13 12 11 10 9 8 7 6 5 4 3 2 1 0																																		
ID																															A	A	A	A	A
Reset 0x00000000	0 0																																		
ID	Acce	Field	Value ID	Value	Description																														
A	RW	PSELN			Analog negative input, enables differential channel																														
			NC	0	Not connected																														
			AnalogInput0	1	AIN0																														
			AnalogInput1	2	AIN1																														
			AnalogInput2	3	AIN2																														
			AnalogInput3	4	AIN3																														
			AnalogInput4	5	AIN4																														
			AnalogInput5	6	AIN5																														
			AnalogInput6	7	AIN6																														
			AnalogInput7	8	AIN7																														
			VDD	9	VDD																														

6.17.11.20 CH[n].CONFIG (n=0..7)

Address offset: $0x518 + (n \times 0x10)$

Input configuration for CH[n]

Bit number	31 30 29 28 27 26 25 24 23 22 21 20 19 18 17 16 15 14 13 12 11 10 9 8 7 6 5 4 3 2 1 0																																			
ID																G	F			E	E	E	D			C	C	C	B			B	A			A
Reset 0x00020000	0 0																																			
ID	Acce	Field	Value ID	Value	Description																															
A	RW	RESP			Positive channel resistor control																															
			Bypass	0	Bypass resistor ladder																															
			Pulldown	1	Pull-down to GND																															
			Pullup	2	Pull-up to VDD																															
			VDD1_2	3	Set input at VDD/2																															
B	RW	RESN			Negative channel resistor control																															
			Bypass	0	Bypass resistor ladder																															

Bit number		31 30 29 28 27 26 25 24 23 22 21 20 19 18 17 16 15 14 13 12 11 10 9 8 7 6 5 4 3 2 1 0																															
ID		G								F			E E E			D			C C C			B B		A A									
Reset 0x00020000		0 0 0 0 0 0 0 0 0 0 0 0 0 0 0 0 1 0																															
ID	Acce Field	Value ID	Value	Description																													
		Pulldown	1	Pull-down to GND																													
		Pullup	2	Pull-up to VDD																													
		VDD1_2	3	Set input at VDD/2																													
C	RW GAIN			Gain control																													
		Gain1_6	0	1/6																													
		Gain1_5	1	1/5																													
		Gain1_4	2	1/4																													
		Gain1_3	3	1/3																													
		Gain1_2	4	1/2																													
		Gain1	5	1																													
		Gain2	6	2																													
		Gain4	7	4																													
D	RW REFSEL			Reference control																													
		Internal	0	Internal reference (0.6 V)																													
		VDD1_4	1	VDD/4 as reference																													
E	RW TACQ			Acquisition time, the time the ADC uses to sample the input voltage																													
		3us	0	3 us																													
		5us	1	5 us																													
		10us	2	10 us																													
		15us	3	15 us																													
		20us	4	20 us																													
		40us	5	40 us																													
F	RW MODE			Enable differential mode																													
		SE	0	Single ended, PSELN will be ignored, negative input to ADC shorted to GND																													
		Diff	1	Differential																													
G	RW BURST			Enable burst mode																													
		Disabled	0	Burst mode is disabled (normal operation)																													
		Enabled	1	Burst mode is enabled. SAADC takes 2 ^{OVERSAMPLE} number of samples as fast as it can, and sends the average to Data RAM.																													

6.17.11.21 CH[n].LIMIT (n=0..7)

Address offset: 0x51C + (n × 0x10)

High/low limits for event monitoring a channel

Bit number		31 30 29 28 27 26 25 24 23 22 21 20 19 18 17 16 15 14 13 12 11 10 9 8 7 6 5 4 3 2 1 0																															
ID		B B B B B B B B B B B B B B B B A A A A A A A A A A A A A A A A A A																															
Reset 0x7FFF8000		0 1 1 1 1 1 1 1 1 1 1 1 1 1 1 1 1 1 0 0 0 0 0 0 0 0 0 0 0 0 0 0 0 0																															
ID	Acce Field	Value ID	Value	Description																													
A	RW LOW		[-32768 to +32767]	Low level limit																													
B	RW HIGH		[-32768 to +32767]	High level limit																													

6.17.11.22 RESOLUTION

Address offset: 0x5F0

Resolution configuration

Bit number	31	30	29	28	27	26	25	24	23	22	21	20	19	18	17	16	15	14	13	12	11	10	9	8	7	6	5	4	3	2	1	0
ID																												A	A	A		
Reset 0x00000001	0 1																															
ID	Acce	Field	Value ID	Value	Description																											
A	RW	VAL			Set the resolution																											
			8bit	0	8 bit																											
			10bit	1	10 bit																											
			12bit	2	12 bit																											
			14bit	3	14 bit																											

6.17.11.23 OVERSAMPLE

Address offset: 0x5F4

Oversampling configuration. OVERSAMPLE should not be combined with SCAN. The RESOLUTION is applied before averaging, thus for high OVERSAMPLE a higher RESOLUTION should be used.

Bit number	31	30	29	28	27	26	25	24	23	22	21	20	19	18	17	16	15	14	13	12	11	10	9	8	7	6	5	4	3	2	1	0
ID																												A	A	A	A	
Reset 0x00000000	0 0																															
ID	Acce	Field	Value ID	Value	Description																											
A	RW	OVERSAMPLE			Oversample control																											
			Bypass	0	Bypass oversampling																											
			Over2x	1	Oversample 2x																											
			Over4x	2	Oversample 4x																											
			Over8x	3	Oversample 8x																											
			Over16x	4	Oversample 16x																											
			Over32x	5	Oversample 32x																											
			Over64x	6	Oversample 64x																											
			Over128x	7	Oversample 128x																											
			Over256x	8	Oversample 256x																											

6.17.11.24 SAMPLERATE

Address offset: 0x5F8

Controls normal or continuous sample rate

Bit number	31	30	29	28	27	26	25	24	23	22	21	20	19	18	17	16	15	14	13	12	11	10	9	8	7	6	5	4	3	2	1	0																								
ID																												B	A	A	A	A	A	A	A	A	A	A	A	A	A	A	A	A	A	A	A	A	A	A	A	A	A	A	A	A
Reset 0x00000000	0 0																																																							
ID	Acce	Field	Value ID	Value	Description																																																			
A	RW	CC		[80..2047]	Capture and compare value. Sample rate is 16 MHz/CC																																																			
B	RW	MODE			Select mode for sample rate control																																																			
			Task	0	Rate is controlled from SAMPLE task																																																			
			Timers	1	Rate is controlled from local timer (use CC to control the rate)																																																			

6.17.11.25 RESULT.PTR

Address offset: 0x62C

Data pointer

Bit number	31	30	29	28	27	26	25	24	23	22	21	20	19	18	17	16	15	14	13	12	11	10	9	8	7	6	5	4	3	2	1	0	
ID	A	A	A	A	A	A	A	A	A	A	A	A	A	A	A	A	A	A	A	A	A	A	A	A	A	A	A	A	A	A	A	A	A
Reset 0x00000000	0	0	0	0	0	0	0	0	0	0	0	0	0	0	0	0	0	0	0	0	0	0	0	0	0	0	0	0	0	0	0	0	
ID	Acce	Field	Value ID	Value	Description																												
A	RW	PTR			Data pointer																												

6.17.11.26 RESULT.MAXCNT

Address offset: 0x630

Maximum number of buffer words to transfer

Bit number	31	30	29	28	27	26	25	24	23	22	21	20	19	18	17	16	15	14	13	12	11	10	9	8	7	6	5	4	3	2	1	0						
ID																				A	A	A	A	A	A	A	A	A	A	A	A	A	A	A	A	A	A	A
Reset 0x00000000	0	0	0	0	0	0	0	0	0	0	0	0	0	0	0	0	0	0	0	0	0	0	0	0	0	0	0	0	0	0	0	0						
ID	Acce	Field	Value ID	Value	Description																																	
A	RW	MAXCNT			Maximum number of buffer words to transfer																																	

6.17.11.27 RESULT.AMOUNT

Address offset: 0x634

Number of buffer words transferred since last START

Bit number	31	30	29	28	27	26	25	24	23	22	21	20	19	18	17	16	15	14	13	12	11	10	9	8	7	6	5	4	3	2	1	0						
ID																				A	A	A	A	A	A	A	A	A	A	A	A	A	A	A	A	A	A	A
Reset 0x00000000	0	0	0	0	0	0	0	0	0	0	0	0	0	0	0	0	0	0	0	0	0	0	0	0	0	0	0	0	0	0	0	0						
ID	Acce	Field	Value ID	Value	Description																																	
A	R	AMOUNT			Number of buffer words transferred since last START. This register can be read after an END or STOPPED event.																																	

6.17.12 Electrical specification

6.17.12.1 SAADC Electrical Specification

Symbol	Description	Min.	Typ.	Max.	Units
DNL ₁₀	Differential non-linearity, 10-bit resolution	-0.95	<1		LSB _{10b}
INL ₁₀	Integral non-linearity, 10-bit resolution		1		LSB _{10b}
V _{OS}	Differential offset error (calibrated), 10-bit resolution ^a		+2		LSB _{10b}
DNL ₁₂	Differential non-linearity, 12-bit resolution	-0.95	1.3		LSB _{12b}
INL ₁₂	Integral non-linearity, 12-bit resolution		4.7		LSB _{12b}
C _{EG}	Gain error temperature coefficient		0.02		%/-C
f _{SAMPLE}	Maximum sampling rate			200	kHz
t _{ACQ,10k}	Acquisition time (configurable), source Resistance <= 10kOhm		3		μs
t _{ACQ,40k}	Acquisition time (configurable), source Resistance <= 40kOhm		5		μs
t _{ACQ,100k}	Acquisition time (configurable), source Resistance <= 100kOhm		10		μs
t _{ACQ,200k}	Acquisition time (configurable), source Resistance <= 200kOhm		15		μs

^a Digital output code at zero volt differential input.

Symbol	Description	Min.	Typ.	Max.	Units
t _{ACQ,400k}	Acquisition time (configurable), source Resistance <= 400kOhm		20		μs
t _{ACQ,800k}	Acquisition time (configurable), source Resistance <= 800kOhm		40		μs
t _{CONV}	Conversion time		<2		μs
E _{G1/6}	Error ^b for Gain = 1/6	-3		3	%
E _{G1/4}	Error ^b for Gain = 1/4	-3		3	%
E _{G1/2}	Error ^b for Gain = 1/2	-3		4	%
E _{G1}	Error ^b for Gain = 1	-3		4	%
C _{SAMPLE}	Sample and hold capacitance at maximum gain ²¹		2.5		pF
R _{INPUT}	Input resistance		>1		MΩ
E _{NOB}	Effective number of bits, differential mode, 12-bit resolution, 1/1 gain, 3 μs acquisition time, crystal HFCLK, 200 ksp/s		9		Bit
S _{NDR}	Peak signal to noise and distortion ratio, differential mode, 12-bit resolution, 1/1 gain, 3 μs acquisition time, crystal HFCLK, 200 ksp/s		56		dB
S _{FDR}	Spurious free dynamic range, differential mode, 12-bit resolution, 1/1 gain, 3 μs acquisition time, crystal HFCLK, 200 ksp/s		70		dBc
R _{LADDER}	Ladder resistance		160		kΩ

6.17.13 Performance factors

Clock jitter, affecting sample timing accuracy, and circuit noise can affect ADC performance.

Jitter can be between START tasks or from START task to acquisition. START timer accuracy and startup times of regulators and references will contribute to variability. Sources of circuit noise may include CPU activity and the DC/DC regulator. Best ADC performance is achieved using START timing based on the TIMER module, HFXO clock source, and Constant Latency mode.

6.18 SPI — Serial peripheral interface master

The SPI master provides a simple CPU interface which includes a TXD register for sending data and an RXD register for receiving data. This section is added for legacy support for now.

^b Does not include temperature drift

²¹ Maximum gain corresponds to highest capacitance.

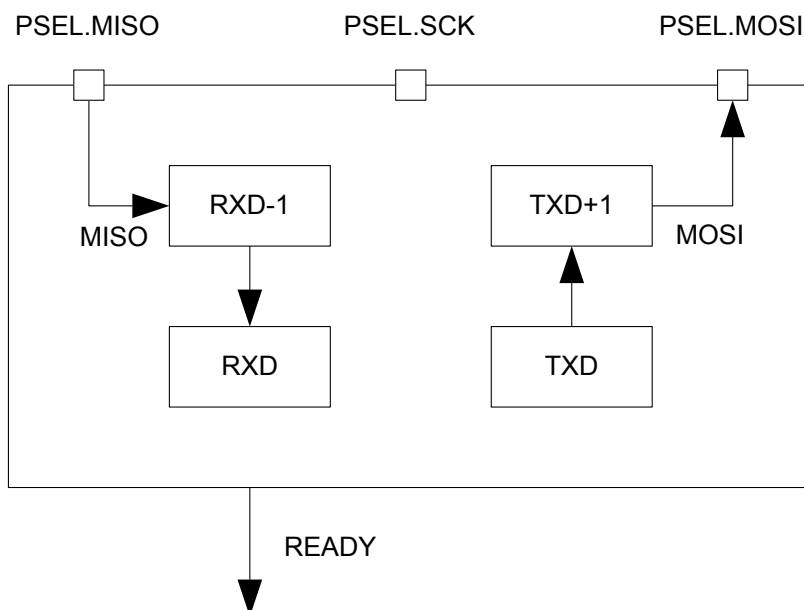

Figure 97: SPI master

RXD-1 and TXD+1 illustrate the double buffered version of RXD and TXD respectively.

6.18.1 Functional description

The TXD and RXD registers are double-buffered to enable some degree of uninterrupted data flow in and out of the SPI master.

The SPI master does not implement support for chip select directly. Therefore, the CPU must use available GPIOs to select the correct slave and control this independently of the SPI master. The SPI master supports SPI modes 0 through 3.

Mode	Clock polarity	Clock phase
	CPOL	CPHA
SPI_MODE0	0 (Leading)	0 (Active high)
SPI_MODE1	0 (Leading)	1 (Active low)
SPI_MODE2	1 (Trailing)	0 (Active high)
SPI_MODE3	1 (Trailing)	1 (Active low)

Table 74: SPI modes

6.18.1.1 SPI master mode pin configuration

The different signals SCK, MOSI, and MISO associated with the SPI master are mapped to physical pins.

This mapping is according to the configuration specified in the PSEL.SCK, PSEL.MOSI, and PSEL.MISO registers respectively. If the CONNECT field of a PSEL.xxx register is set to Disconnected, the associated SPI master signal is not connected to any physical pin. The PSEL.SCK, PSEL.MOSI, and PSEL.MISO registers and their configurations are only used as long as the SPI master is enabled, and retained only as long as the device is in ON mode. PSEL.SCK, PSEL.MOSI, and PSEL.MISO must only be configured when the SPI master is disabled.

To secure correct behavior in the SPI, the pins used by the SPI must be configured in the GPIO peripheral as described in [GPIO configuration](#) on page 255 prior to enabling the SPI. The SCK must always be connected to a pin, and that pin's input buffer must always be connected for the SPI to work. This configuration must be retained in the GPIO for the selected IOs as long as the SPI is enabled.

Only one peripheral can be assigned to drive a particular GPIO pin at a time, failing to do so may result in unpredictable behavior.

SPI master signal	SPI master pin	Direction	Output value
SCK	As specified in PSEL.SCK	Output	Same as CONFIG.CPOL
MOSI	As specified in PSEL.MOSI	Output	0
MISO	As specified in PSEL.MISO	Input	Not applicable

Table 75: GPIO configuration

6.18.1.2 Shared resources

The SPI shares registers and other resources with other peripherals that have the same ID as the SPI. Therefore, the user must disable all peripherals that have the same ID as the SPI before the SPI can be configured and used.

Disabling a peripheral that has the same ID as the SPI will not reset any of the registers that are shared with the SPI. It is therefore important to configure all relevant SPI registers explicitly to secure that it operates correctly.

See the Instantiation table in [Instantiation](#) on page 19 for details on peripherals and their IDs.

6.18.1.3 SPI master transaction sequence

An SPI master transaction is started by writing the first byte, which is to be transmitted by the SPI master, to the TXD register.

Since the transmitter is double buffered, the second byte can be written to the TXD register immediately after the first one. The SPI master will then send these bytes in the order they are written to the TXD register.

The SPI master is a synchronous interface, and for every byte that is sent, a different byte will be received at the same time; this is illustrated in [SPI master transaction](#) on page 256. Bytes that are received will be moved to the RXD register where the CPU can extract them by reading the register. The RXD register is double buffered in the same way as the TXD register, and a second byte can therefore be received at the same time as the first byte is being extracted from RXD by the CPU. The SPI master will generate a READY event every time a new byte is moved to the RXD register. The double buffered byte will be moved from RXD-1 to RXD as soon as the first byte is extracted from RXD. The SPI master will stop when there are no more bytes to send in TXD and TXD+1.

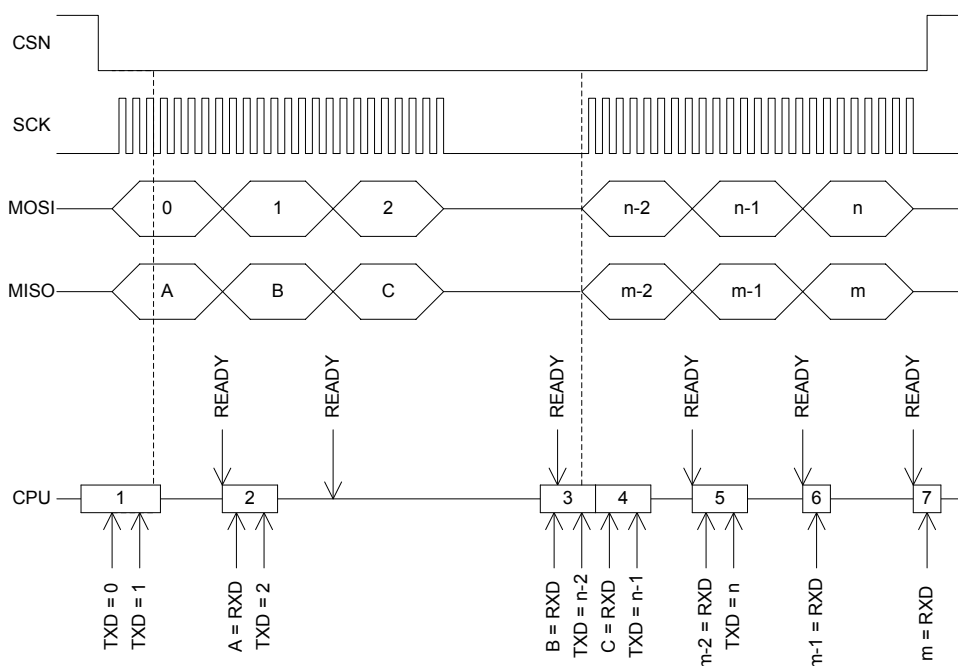

Figure 98: SPI master transaction

The READY event of the third byte transaction is delayed until B is extracted from RXD in occurrence number 3 on the horizontal lifeline. The reason for this is that the third event is generated first when C is moved from RXD-1 to RXD after B is read.

The SPI master will move the incoming byte to the RXD register after a short delay following the SCK clock period of the last bit in the byte. This also means that the READY event will be delayed accordingly, see [SPI master transaction](#) on page 256. Therefore, it is important that you always clear the READY event, even if the RXD register and the data that is being received is not used.

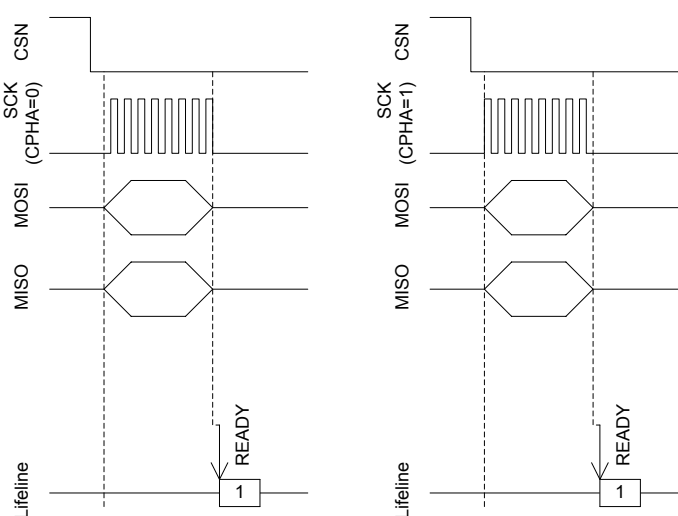

Figure 99: SPI master transaction

6.18.2 Registers

Base address	Peripheral	Instance	Description	Configuration
0x40004000	SPI	SPIO	SPI master	Deprecated

Table 76: Instances

Register	Offset	Description
EVENTS_READY	0x108	TXD byte sent and RXD byte received
INTENSET	0x304	Enable interrupt
INTENCLR	0x308	Disable interrupt
ENABLE	0x500	Enable SPI
PSEL_SCK	0x508	Pin select for SCK
PSEL_MOSI	0x50C	Pin select for MOSI signal
PSEL_MISO	0x510	Pin select for MISO signal
RXD	0x518	RXD register
TXD	0x51C	TXD register
FREQUENCY	0x524	SPI frequency. Accuracy depends on the HFCLK source selected.
CONFIG	0x554	Configuration register

Table 77: Register overview

6.18.2.1 EVENTS_READY

Address offset: 0x108

TXD byte sent and RXD byte received

Bit number	31 30 29 28 27 26 25 24 23 22 21 20 19 18 17 16 15 14 13 12 11 10 9 8 7 6 5 4 3 2 1 0																															
ID																																A
Reset 0x00000000	0 0																															
ID	Acce Field	Value ID	Value	Description																												
A	RW EVENTS_READY			TXD byte sent and RXD byte received																												
		NotGenerated	0	Event not generated																												
		Generated	1	Event generated																												

6.18.2.2 INTENSET

Address offset: 0x304

Enable interrupt

Bit number	31 30 29 28 27 26 25 24 23 22 21 20 19 18 17 16 15 14 13 12 11 10 9 8 7 6 5 4 3 2 1 0																															
ID																																A
Reset 0x00000000	0 0																															
ID	Acce Field	Value ID	Value	Description																												
A	RW READY			Write '1' to enable interrupt for event READY																												
		Set	1	Enable																												
		Disabled	0	Read: Disabled																												
		Enabled	1	Read: Enabled																												

6.18.2.3 INTENCLR

Address offset: 0x308

Disable interrupt

Bit number	31	30	29	28	27	26	25	24	23	22	21	20	19	18	17	16	15	14	13	12	11	10	9	8	7	6	5	4	3	2	1	0
ID																												A				
Reset 0x00000000	0 0																															
ID	Acce Field	Value ID	Value	Description																												
A	RW	READY		Write '1' to disable interrupt for event READY																												
		Clear	1	Disable																												
		Disabled	0	Read: Disabled																												
		Enabled	1	Read: Enabled																												

6.18.2.4 ENABLE

Address offset: 0x500

Enable SPI

Bit number	31	30	29	28	27	26	25	24	23	22	21	20	19	18	17	16	15	14	13	12	11	10	9	8	7	6	5	4	3	2	1	0
ID																												A	A	A	A	
Reset 0x00000000	0 0																															
ID	Acce Field	Value ID	Value	Description																												
A	RW	ENABLE		Enable or disable SPI																												
		Disabled	0	Disable SPI																												
		Enabled	1	Enable SPI																												

6.18.2.5 PSEL.SCK

Address offset: 0x508

Pin select for SCK

Bit number	31	30	29	28	27	26	25	24	23	22	21	20	19	18	17	16	15	14	13	12	11	10	9	8	7	6	5	4	3	2	1	0
ID	C																											A	A	A	A	A
Reset 0xFFFFFFFF	1 1																															
ID	Acce Field	Value ID	Value	Description																												
A	RW	PIN	[0..31]	Pin number																												
C	RW	CONNECT		Connection																												
		Disconnected	1	Disconnect																												
		Connected	0	Connect																												

6.18.2.6 PSEL.MOSI

Address offset: 0x50C

Pin select for MOSI signal

Bit number	31	30	29	28	27	26	25	24	23	22	21	20	19	18	17	16	15	14	13	12	11	10	9	8	7	6	5	4	3	2	1	0
ID	C																											A	A	A	A	A
Reset 0xFFFFFFFF	1 1																															
ID	Acce Field	Value ID	Value	Description																												
A	RW	PIN	[0..31]	Pin number																												
C	RW	CONNECT		Connection																												
		Disconnected	1	Disconnect																												
		Connected	0	Connect																												

6.18.2.7 PSEL.MISO

Address offset: 0x510

Pin select for MISO signal

Bit number	31 30 29 28 27 26 25 24 23 22 21 20 19 18 17 16 15 14 13 12 11 10 9 8 7 6 5 4 3 2 1 0																														
ID	C																											A A A A A			
Reset 0xFFFFFFFF	1 1																														
ID	Acce Field	Value ID	Value	Description																											
A	RW PIN		[0..31]	Pin number																											
C	RW CONNECT			Connection																											
		Disconnected	1	Disconnect																											
		Connected	0	Connect																											

6.18.2.8 RXD

Address offset: 0x518

RXD register

Bit number	31 30 29 28 27 26 25 24 23 22 21 20 19 18 17 16 15 14 13 12 11 10 9 8 7 6 5 4 3 2 1 0																														
ID																												A A A A A A A A			
Reset 0x00000000	0 0																														
ID	Acce Field	Value ID	Value	Description																											
A	R	RXD		RX data received. Double buffered																											

6.18.2.9 TXD

Address offset: 0x51C

TXD register

Bit number	31 30 29 28 27 26 25 24 23 22 21 20 19 18 17 16 15 14 13 12 11 10 9 8 7 6 5 4 3 2 1 0																														
ID																												A A A A A A A A			
Reset 0x00000000	0 0																														
ID	Acce Field	Value ID	Value	Description																											
A	RW	TXD		TX data to send. Double buffered																											

6.18.2.10 FREQUENCY

Address offset: 0x524

SPI frequency. Accuracy depends on the HFCLK source selected.

Bit number	31	30	29	28	27	26	25	24	23	22	21	20	19	18	17	16	15	14	13	12	11	10	9	8	7	6	5	4	3	2	1	0
ID	A	A	A	A	A	A	A	A	A	A	A	A	A	A	A	A	A	A	A	A	A	A	A	A	A	A	A	A	A	A	A	A
Reset 0x04000000	0	0	0	0	0	1	0	0	0	0	0	0	0	0	0	0	0	0	0	0	0	0	0	0	0	0	0	0	0	0	0	0
ID	Acce	Field	Value ID	Value	Description																											
A	RW	FREQUENCY			SPI master data rate																											
			K125	0x02000000	125 kbps																											
			K250	0x04000000	250 kbps																											
			K500	0x08000000	500 kbps																											
			M1	0x10000000	1 Mbps																											
			M2	0x20000000	2 Mbps																											
			M4	0x40000000	4 Mbps																											
			M8	0x80000000	8 Mbps																											

6.18.2.11 CONFIG

Address offset: 0x554

Configuration register

Bit number	31	30	29	28	27	26	25	24	23	22	21	20	19	18	17	16	15	14	13	12	11	10	9	8	7	6	5	4	3	2	1	0		
ID																																C	B	A
Reset 0x00000000	0	0	0	0	0	0	0	0	0	0	0	0	0	0	0	0	0	0	0	0	0	0	0	0	0	0	0	0	0	0	0	0	0	
ID	Acce	Field	Value ID	Value	Description																													
A	RW	ORDER			Bit order																													
			MsbFirst	0	Most significant bit shifted out first																													
			LsbFirst	1	Least significant bit shifted out first																													
B	RW	CPHA			Serial clock (SCK) phase																													
			Leading	0	Sample on leading edge of clock, shift serial data on trailing edge																													
			Trailing	1	Sample on trailing edge of clock, shift serial data on leading edge																													
C	RW	CPOL			Serial clock (SCK) polarity																													
			ActiveHigh	0	Active high																													
			ActiveLow	1	Active low																													

6.18.3 Electrical specification

6.18.3.1 SPI master interface electrical specifications

Symbol	Description	Min.	Typ.	Max.	Units
f_{SPI}	Bit rates for SPI ²²			g^{23}	Mbps
$t_{\text{SPI,START}}$	Time from writing TXD register to transmission started		1		μs

6.18.3.2 Serial Peripheral Interface (SPI) Master timing specifications

Symbol	Description	Min.	Typ.	Max.	Units
$t_{\text{SPI,CCLK}}$	SCK period	125			ns
$t_{\text{SPI,RSCCK,LD}}$	SCK rise time, standard drive ^a			$t_{\text{RF,25pF}}$	

²² High bit rates may require GPIOs to be set as High Drive, see GPIO chapter for more details.

²³ The actual maximum data rate depends on the slave's CLK to MISO and MOSI setup and hold timings.

^a At 25pF load, including GPIO capacitance, see GPIO spec.

Symbol	Description	Min.	Typ.	Max.	Units
$t_{\text{SPI,RSCK,HD}}$	SCK rise time, high drive ^a			$t_{\text{HRRF,25pF}}$	
$t_{\text{SPI,FSCK,LD}}$	SCK fall time, standard drive ^a			$t_{\text{RF,25pF}}$	
$t_{\text{SPI,FSCK,HD}}$	SCK fall time, high drive ^a			$t_{\text{HRRF,25pF}}$	
$t_{\text{SPI,WHSCK}}$	SCK high time ^a	$(t_{\text{CSCK}}/2)$			
		$-t_{\text{RSCK}}$			
$t_{\text{SPI,WLSCK}}$	SCK low time ^a	$(t_{\text{CSCK}}/2)$			
		$-t_{\text{FSCK}}$			
$t_{\text{SPI,SUMI}}$	MISO to CLK edge setup time	19			ns
$t_{\text{SPI,HMI}}$	CLK edge to MISO hold time	18			ns
$t_{\text{SPI,VMO}}$	CLK edge to MOSI valid			59	ns
$t_{\text{SPI,HMO}}$	MOSI hold time after CLK edge	20			ns

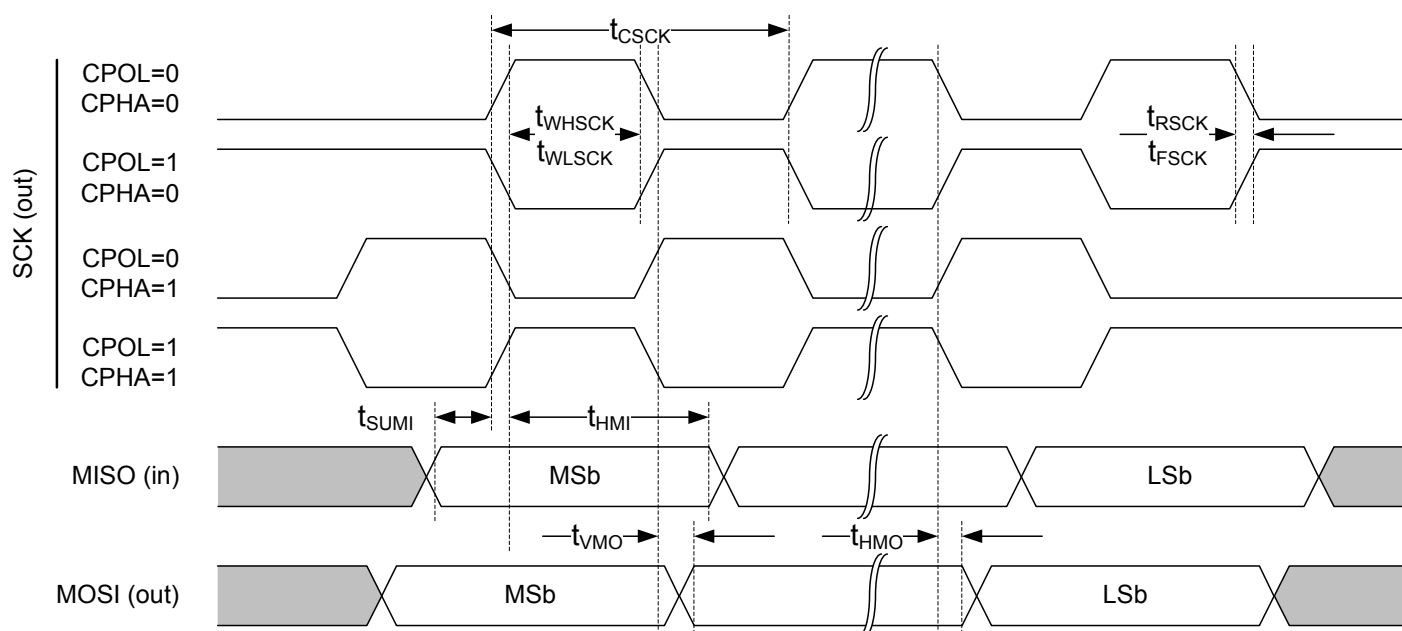

Figure 100: SPI master timing diagram

6.19 SPIM — Serial peripheral interface master with EasyDMA

The SPI master can communicate with multiple slaves using individual chip select signals for each of the slave devices attached to a bus.

Listed here are the main features for the SPIM

- SPI mode 0-3
- EasyDMA direct transfer to/from RAM for both SPI Slave and SPI Master
- Individual selection of IO pin for each SPI signal

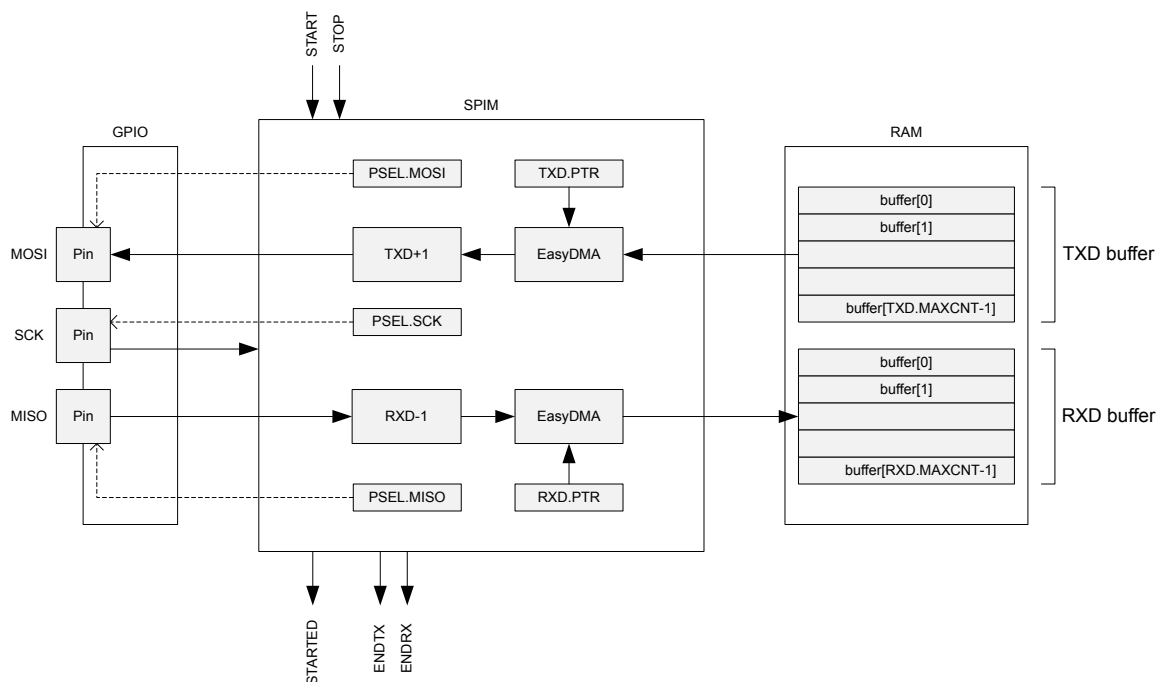

Figure 101: SPIM — SPI master with EasyDMA

The SPIM does not implement support for chip select directly. Therefore, the CPU must use available GPIOs to select the correct slave and control this independently of the SPI master. The SPIM supports SPI modes 0 through 3. The CONFIG register allows setting CPOL and CPHA appropriately.

Mode	Clock polarity	Clock phase
	CPOL	CPHA
SPI_MODE0	0 (Active High)	0 (Leading)
SPI_MODE1	0 (Active High)	1 (Trailing)
SPI_MODE2	1 (Active Low)	0 (Leading)
SPI_MODE3	1 (Active Low)	1 (Trailing)

Table 78: SPI modes

6.19.1 SPI master transaction sequence

An SPI master transaction consists of a sequence started by the START task followed by a number of events, and finally the STOP task.

An SPI master transaction is started by triggering the START task. The ENDTX event will be generated when the transmitter has transmitted all bytes in the TXD buffer as specified in the TXD.MAXCNT register. The ENDRX event will be generated when the receiver has filled the RXD buffer, i.e. received the last possible byte as specified in the RXD.MAXCNT register.

Following a START task, the SPI master will generate an END event when both ENDRX and ENDTX have been generated.

The SPI master is stopped by triggering the STOP task. A STOPPED event is generated when the SPI master has stopped.

If the ENDRX event has not already been generated when the SPI master has come to a stop, the SPI master will generate the ENDRX event explicitly even though the RX buffer is not full.

If the ENDTX event has not already been generated when the SPI master has come to a stop, the SPI master will generate the ENDTX event explicitly even though all bytes in the TXD buffer, as specified in the TXD.MAXCNT register, have not been transmitted.

The SPI master is a synchronous interface, and for every byte that is sent, a different byte will be received at the same time; this is illustrated in [SPI master transaction](#) on page 263.

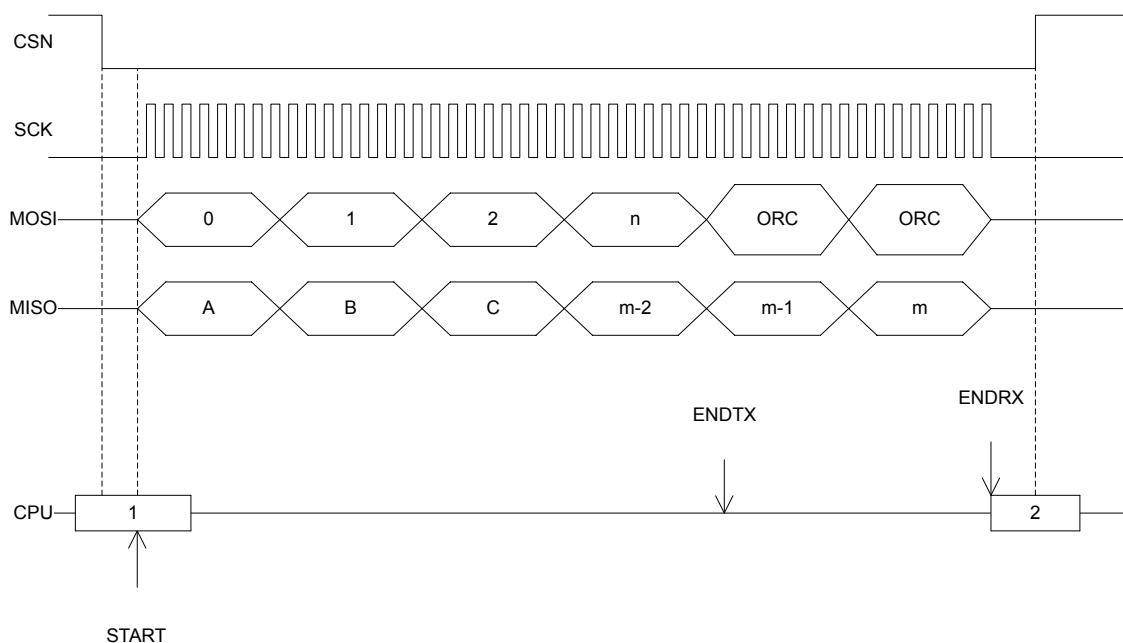

Figure 102: SPI master transaction

6.19.2 Master mode pin configuration

The SCK, MOSI, and MISO signals associated with the SPI master are mapped to physical pins according to the configuration specified in the PSEL.SCK, PSEL.MOSI, and PSEL.MISO registers respectively.

The PSEL.SCK, PSEL.MOSI, and PSEL.MISO registers and their configurations are only used as long as the SPI master is enabled, and retained only as long as the device is in ON mode. PSEL.SCK, PSEL.MOSI and PSEL.MISO must only be configured when the SPI master is disabled.

To secure correct behavior in the SPI, the pins used by the SPI must be configured in the GPIO peripheral as described in [GPIO configuration](#) on page 263 prior to enabling the SPI. This configuration must be retained in the GPIO for the selected IOs as long as the SPI is enabled.

Only one peripheral can be assigned to drive a particular GPIO pin at a time. Failing to do so may result in unpredictable behavior.

SPI master signal	SPI master pin	Direction	Output value
SCK	As specified in PSEL.SCK	Output	Same as CONFIG.CPOL
MOSI	As specified in PSEL.MOSI	Output	0
MISO	As specified in PSEL.MISO	Input	Not applicable

Table 79: GPIO configuration

6.19.3 EasyDMA

The SPIM implements EasyDMA for accessing RAM without CPU involvement.

The SPIM peripheral implements the following EasyDMA channels:

Channel	Type	Register Cluster
TXD	READER	TXD
RXD	WRITER	RXD

Table 80: SPIM EasyDMA Channels

For detailed information regarding the use of EasyDMA, see [EasyDMA](#) on page 36.

The .PTR and .MAXCNT registers are double-buffered. They can be updated and prepared for the next transmission immediately after having received the STARTED event.

The SPI master will automatically stop transmitting after TXD.MAXCNT bytes have been transmitted and RXD.MAXCNT bytes have been received. If RXD.MAXCNT is larger than TXD.MAXCNT, the remaining transmitted bytes will contain the value defined in the ORC register. If TXD.MAXCNT is larger than RXD.MAXCNT, the superfluous received bytes will be discarded.

The ENDRX/ENDTX event indicate that EasyDMA has finished accessing respectively the RX/TX buffer in RAM. The END event gets generated when both RX and TX are finished accessing the buffers in RAM.

In the case of bus congestion as described in , data loss may occur.

6.19.4 Low power

When putting the system in low power and the peripheral is not needed, lowest possible power consumption is achieved by stopping, and then disabling the peripheral.

The STOP task may not be always needed (the peripheral might already be stopped), but if it is sent, software shall wait until the STOPPED event was received as a response before disabling the peripheral through the ENABLE register.

6.19.5 Registers

Base address	Peripheral	Instance	Description	Configuration
0x40004000	SPIM	SPIM0	SPI master	

Table 81: Instances

Register	Offset	Description
TASKS_START	0x010	Start SPI transaction
TASKS_STOP	0x014	Stop SPI transaction
TASKS_SUSPEND	0x01C	Suspend SPI transaction
TASKS_RESUME	0x020	Resume SPI transaction
EVENTS_STOPPED	0x104	SPI transaction has stopped
EVENTS_ENDRX	0x110	End of RXD buffer reached
EVENTS_END	0x118	End of RXD buffer and TXD buffer reached
EVENTS_ENDTX	0x120	End of TXD buffer reached
EVENTS_STARTED	0x14C	Transaction started
SHORTS	0x200	Shortcuts between local events and tasks
INTENSET	0x304	Enable interrupt

Register	Offset	Description
INTENCLR	0x308	Disable interrupt
ENABLE	0x500	Enable SPIM
PSEL.SCK	0x508	Pin select for SCK
PSEL.MOSI	0x50C	Pin select for MOSI signal
PSEL.MISO	0x510	Pin select for MISO signal
FREQUENCY	0x524	SPI frequency. Accuracy depends on the HFCLK source selected.
RXD.PTR	0x534	Data pointer
RXD.MAXCNT	0x538	Maximum number of bytes in receive buffer
RXD.AMOUNT	0x53C	Number of bytes transferred in the last transaction
RXD.LIST	0x540	EasyDMA list type
TXD.PTR	0x544	Data pointer
TXD.MAXCNT	0x548	Maximum number of bytes in transmit buffer
TXD.AMOUNT	0x54C	Number of bytes transferred in the last transaction
TXD.LIST	0x550	EasyDMA list type
CONFIG	0x554	Configuration register
ORC	0x5C0	Over-read character. Character clocked out in case and over-read of the TXD buffer.

Table 82: Register overview

6.19.5.1 TASKS_START

Address offset: 0x010

Start SPI transaction

Bit number	31 30 29 28 27 26 25 24 23 22 21 20 19 18 17 16 15 14 13 12 11 10 9 8 7 6 5 4 3 2 1 0																														
ID	A																														
Reset 0x00000000	0 0																														
ID	Access	Field	Value ID	Value	Description																										
A	W	TASKS_START			Start SPI transaction																										
			Trigger	1	Trigger task																										

6.19.5.2 TASKS_STOP

Address offset: 0x014

Stop SPI transaction

Bit number	31 30 29 28 27 26 25 24 23 22 21 20 19 18 17 16 15 14 13 12 11 10 9 8 7 6 5 4 3 2 1 0																														
ID	A																														
Reset 0x00000000	0 0																														
ID	Access	Field	Value ID	Value	Description																										
A	W	TASKS_STOP			Stop SPI transaction																										
			Trigger	1	Trigger task																										

6.19.5.3 TASKS_SUSPEND

Address offset: 0x01C

Suspend SPI transaction

Bit number	31	30	29	28	27	26	25	24	23	22	21	20	19	18	17	16	15	14	13	12	11	10	9	8	7	6	5	4	3	2	1	0
ID																																A
Reset 0x00000000	0 0																															
ID	Acce	Field	Value ID	Value	Description																											
A	W	TASKS_SUSPEND	Trigger	1	Suspend SPI transaction Trigger task																											

6.19.5.4 TASKS_RESUME

Address offset: 0x020

Resume SPI transaction

Bit number	31	30	29	28	27	26	25	24	23	22	21	20	19	18	17	16	15	14	13	12	11	10	9	8	7	6	5	4	3	2	1	0
ID																																A
Reset 0x00000000	0 0																															
ID	Acce	Field	Value ID	Value	Description																											
A	W	TASKS_RESUME	Trigger	1	Resume SPI transaction Trigger task																											

6.19.5.5 EVENTS_STOPPED

Address offset: 0x104

SPI transaction has stopped

Bit number	31	30	29	28	27	26	25	24	23	22	21	20	19	18	17	16	15	14	13	12	11	10	9	8	7	6	5	4	3	2	1	0
ID																																A
Reset 0x00000000	0 0																															
ID	Acce	Field	Value ID	Value	Description																											
A	RW	EVENTS_STOPPED	NotGenerated	0	SPI transaction has stopped Event not generated																											
			Generated	1	Event generated																											

6.19.5.6 EVENTS_ENDRX

Address offset: 0x110

End of RXD buffer reached

Bit number	31	30	29	28	27	26	25	24	23	22	21	20	19	18	17	16	15	14	13	12	11	10	9	8	7	6	5	4	3	2	1	0
ID																																A
Reset 0x00000000	0 0																															
ID	Acce	Field	Value ID	Value	Description																											
A	RW	EVENTS_ENDRX	NotGenerated	0	End of RXD buffer reached Event not generated																											
			Generated	1	Event generated																											

6.19.5.7 EVENTS_END

Address offset: 0x118

End of RXD buffer and TXD buffer reached

Bit number	31	30	29	28	27	26	25	24	23	22	21	20	19	18	17	16	15	14	13	12	11	10	9	8	7	6	5	4	3	2	1	0
ID																																A
Reset 0x00000000	0 0																															
ID	Acce Field	Value ID	Value	Description																												
A	RW EVENTS_END	NotGenerated	0	End of RXD buffer and TXD buffer reached Event not generated																												
		Generated	1	Event generated																												

6.19.5.8 EVENTS_ENDTX

Address offset: 0x120

End of TXD buffer reached

Bit number	31	30	29	28	27	26	25	24	23	22	21	20	19	18	17	16	15	14	13	12	11	10	9	8	7	6	5	4	3	2	1	0
ID																																A
Reset 0x00000000	0 0																															
ID	Acce Field	Value ID	Value	Description																												
A	RW EVENTS_ENDTX	NotGenerated	0	End of TXD buffer reached Event not generated																												
		Generated	1	Event generated																												

6.19.5.9 EVENTS_STARTED

Address offset: 0x14C

Transaction started

Bit number	31	30	29	28	27	26	25	24	23	22	21	20	19	18	17	16	15	14	13	12	11	10	9	8	7	6	5	4	3	2	1	0
ID																																A
Reset 0x00000000	0 0																															
ID	Acce Field	Value ID	Value	Description																												
A	RW EVENTS_STARTED	NotGenerated	0	Transaction started Event not generated																												
		Generated	1	Event generated																												

6.19.5.10 SHORTS

Address offset: 0x200

Shortcuts between local events and tasks

Bit number	31	30	29	28	27	26	25	24	23	22	21	20	19	18	17	16	15	14	13	12	11	10	9	8	7	6	5	4	3	2	1	0
ID																																A
Reset 0x00000000	0 0																															
ID	Acce Field	Value ID	Value	Description																												
A	RW END_START	Disabled	0	Shortcut between event END and task START Disable shortcut																												
		Enabled	1	Enable shortcut																												

6.19.5.11 INTENSET

Address offset: 0x304

Enable interrupt

Bit number		31 30 29 28 27 26 25 24 23 22 21 20 19 18 17 16 15 14 13 12 11 10 9 8 7 6 5 4 3 2 1 0																														
ID		E															D					C			B			A				
Reset 0x00000000		0 0																														
ID	Acce Field	Value ID	Value	Description																												
A	RW STOPPED			Write '1' to enable interrupt for event STOPPED																												
		Set	1	Enable																												
		Disabled	0	Read: Disabled																												
B	RW ENDRX	Enabled	1	Read: Enabled																												
		Set	1	Enable																												
		Disabled	0	Read: Disabled																												
C	RW END	Enabled	1	Read: Enabled																												
		Set	1	Enable																												
		Disabled	0	Read: Disabled																												
D	RW ENDTX	Enabled	1	Read: Enabled																												
		Set	1	Enable																												
		Disabled	0	Read: Disabled																												
E	RW STARTED	Enabled	1	Read: Enabled																												
		Set	1	Enable																												
		Disabled	0	Read: Disabled																												

6.19.5.12 INTENCLR

Address offset: 0x308

Disable interrupt

Bit number		31 30 29 28 27 26 25 24 23 22 21 20 19 18 17 16 15 14 13 12 11 10 9 8 7 6 5 4 3 2 1 0																														
ID		E															D					C			B			A				
Reset 0x00000000		0 0																														
ID	Acce Field	Value ID	Value	Description																												
A	RW STOPPED			Write '1' to disable interrupt for event STOPPED																												
		Clear	1	Disable																												
		Disabled	0	Read: Disabled																												
B	RW ENDRX	Enabled	1	Read: Enabled																												
		Clear	1	Disable																												
		Disabled	0	Read: Disabled																												
C	RW END	Enabled	1	Read: Enabled																												
		Clear	1	Disable																												
		Disabled	0	Read: Disabled																												
D	RW ENDTX	Enabled	1	Read: Enabled																												
		Clear	1	Disable																												
		Disabled	0	Read: Disabled																												
E	RW STARTED	Disabled	0	Read: Disabled																												
		Clear	1	Disable																												

Bit number	31	30	29	28	27	26	25	24	23	22	21	20	19	18	17	16	15	14	13	12	11	10	9	8	7	6	5	4	3	2	1	0
ID	E																D				C		B		A							
Reset 0x00000000	0 0																															
ID	Acce Field	Value ID	Value	Description																												
		Enabled	1	Read: Enabled																												

6.19.5.13 ENABLE

Address offset: 0x500

Enable SPIM

Bit number	31	30	29	28	27	26	25	24	23	22	21	20	19	18	17	16	15	14	13	12	11	10	9	8	7	6	5	4	3	2	1	0				
ID																													A		A		A		A	
Reset 0x00000000	0 0																																			
ID	Acce Field	Value ID	Value	Description																																
A	RW ENABLE			Enable or disable SPIM																																
		Disabled	0	Disable SPIM																																
		Enabled	7	Enable SPIM																																

6.19.5.14 PSEL.SCK

Address offset: 0x508

Pin select for SCK

Bit number	31	30	29	28	27	26	25	24	23	22	21	20	19	18	17	16	15	14	13	12	11	10	9	8	7	6	5	4	3	2	1	0				
ID	C																												A		A		A		A	
Reset 0xFFFFFFFF	1 1																																			
ID	Acce Field	Value ID	Value	Description																																
A	RW PIN		[0..31]	Pin number																																
C	RW CONNECT			Connection																																
		Disconnected	1	Disconnect																																
		Connected	0	Connect																																

6.19.5.15 PSEL.MOSI

Address offset: 0x50C

Pin select for MOSI signal

Bit number	31	30	29	28	27	26	25	24	23	22	21	20	19	18	17	16	15	14	13	12	11	10	9	8	7	6	5	4	3	2	1	0				
ID	C																												A		A		A		A	
Reset 0xFFFFFFFF	1 1																																			
ID	Acce Field	Value ID	Value	Description																																
A	RW PIN		[0..31]	Pin number																																
C	RW CONNECT			Connection																																
		Disconnected	1	Disconnect																																
		Connected	0	Connect																																

6.19.5.16 PSEL.MISO

Address offset: 0x510

Pin select for MISO signal

Bit number	31 30 29 28 27 26 25 24 23 22 21 20 19 18 17 16 15 14 13 12 11 10 9 8 7 6 5 4 3 2 1 0																														
ID	C																											A A A A			
Reset 0xFFFFFFF	1 1																														
ID	Acce Field	Value ID	Value	Description																											
A	RW PIN		[0..31]	Pin number																											
C	RW CONNECT			Connection																											
		Disconnected	1	Disconnect																											
		Connected	0	Connect																											

6.19.5.17 FREQUENCY

Address offset: 0x524

SPI frequency. Accuracy depends on the HFCLK source selected.

Bit number	31 30 29 28 27 26 25 24 23 22 21 20 19 18 17 16 15 14 13 12 11 10 9 8 7 6 5 4 3 2 1 0																														
ID	A A																														
Reset 0x04000000	0 0 0 0 0 1 0																														
ID	Acce Field	Value ID	Value	Description																											
A	RW FREQUENCY			SPI master data rate																											
		K125	0x02000000	125 kbps																											
		K250	0x04000000	250 kbps																											
		K500	0x08000000	500 kbps																											
		M1	0x10000000	1 Mbps																											
		M2	0x20000000	2 Mbps																											
		M4	0x40000000	4 Mbps																											
		M8	0x80000000	8 Mbps																											

6.19.5.18 RXD.PTR

Address offset: 0x534

Data pointer

Bit number	31 30 29 28 27 26 25 24 23 22 21 20 19 18 17 16 15 14 13 12 11 10 9 8 7 6 5 4 3 2 1 0																														
ID	A A																														
Reset 0x00000000	0 0																														
ID	Acce Field	Value ID	Value	Description																											
A	RW PTR			Data pointer																											

Note: See the memory chapter for details about which memories are available for EasyDMA.

6.19.5.19 RXD.MAXCNT

Address offset: 0x538

Maximum number of bytes in receive buffer

Bit number	31 30 29 28 27 26 25 24 23 22 21 20 19 18 17 16 15 14 13 12 11 10 9 8 7 6 5 4 3 2 1 0																														
ID																												A A A A A A A A			
Reset 0x00000000	0 0																														
ID	Acce Field	Value ID	Value	Description																											
A	RW MAXCNT		[1..0x3FF]	Maximum number of bytes in receive buffer																											

6.19.5.20 RXD.AMOUNT

Address offset: 0x53C

Number of bytes transferred in the last transaction

Bit number	31	30	29	28	27	26	25	24	23	22	21	20	19	18	17	16	15	14	13	12	11	10	9	8	7	6	5	4	3	2	1	0
ID	A A																															
Reset 0x00000000	0 0																															
ID	Acce Field	Value ID	Value	Description																												
A	R	AMOUNT	[1..0x3FF]	Number of bytes transferred in the last transaction																												

6.19.5.21 RXD.LIST

Address offset: 0x540

EasyDMA list type

Bit number	31	30	29	28	27	26	25	24	23	22	21	20	19	18	17	16	15	14	13	12	11	10	9	8	7	6	5	4	3	2	1	0
ID	A A																															
Reset 0x00000000	0 0																															
ID	Acce Field	Value ID	Value	Description																												
A	RW	LIST		List type																												
		Disabled	0	Disable EasyDMA list																												
		ArrayList	1	Use array list																												

6.19.5.22 TXD.PTR

Address offset: 0x544

Data pointer

Bit number	31	30	29	28	27	26	25	24	23	22	21	20	19	18	17	16	15	14	13	12	11	10	9	8	7	6	5	4	3	2	1	0
ID	A A																															
Reset 0x00000000	0 0																															
ID	Acce Field	Value ID	Value	Description																												
A	RW	PTR		Data pointer																												

Note: See the memory chapter for details about which memories are available for EasyDMA.

6.19.5.23 TXD.MAXCNT

Address offset: 0x548

Maximum number of bytes in transmit buffer

Bit number	31	30	29	28	27	26	25	24	23	22	21	20	19	18	17	16	15	14	13	12	11	10	9	8	7	6	5	4	3	2	1	0
ID	A A																															
Reset 0x00000000	0 0																															
ID	Acce Field	Value ID	Value	Description																												
A	RW	MAXCNT	[1..0x3FF]	Maximum number of bytes in transmit buffer																												

6.19.5.24 TXD.AMOUNT

Address offset: 0x54C

Number of bytes transferred in the last transaction

Bit number	31	30	29	28	27	26	25	24	23	22	21	20	19	18	17	16	15	14	13	12	11	10	9	8	7	6	5	4	3	2	1	0
ID	A A																															
Reset 0x00000000	0 0																															
ID	Acce Field	Value ID	Value	Description																												
A	R	AMOUNT	[1..0x3FF]	Number of bytes transferred in the last transaction																												

6.19.5.25 TXD.LIST

Address offset: 0x550

EasyDMA list type

Bit number	31	30	29	28	27	26	25	24	23	22	21	20	19	18	17	16	15	14	13	12	11	10	9	8	7	6	5	4	3	2	1	0
ID	A A																															
Reset 0x00000000	0 0																															
ID	Acce Field	Value ID	Value	Description																												
A	RW	LIST		List type																												
		Disabled	0	Disable EasyDMA list																												
		ArrayList	1	Use array list																												

6.19.5.26 CONFIG

Address offset: 0x554

Configuration register

Bit number	31	30	29	28	27	26	25	24	23	22	21	20	19	18	17	16	15	14	13	12	11	10	9	8	7	6	5	4	3	2	1	0
ID	C B A																															
Reset 0x00000000	0 0																															
ID	Acce Field	Value ID	Value	Description																												
A	RW	ORDER		Bit order																												
		MsbFirst	0	Most significant bit shifted out first																												
		LsbFirst	1	Least significant bit shifted out first																												
B	RW	CPHA		Serial clock (SCK) phase																												
		Leading	0	Sample on leading edge of clock, shift serial data on trailing edge																												
		Trailing	1	Sample on trailing edge of clock, shift serial data on leading edge																												
C	RW	CPOL		Serial clock (SCK) polarity																												
		ActiveHigh	0	Active high																												
		ActiveLow	1	Active low																												

6.19.5.27 ORC

Address offset: 0x5C0

Over-read character. Character clocked out in case and over-read of the TXD buffer.

Bit number	31	30	29	28	27	26	25	24	23	22	21	20	19	18	17	16	15	14	13	12	11	10	9	8	7	6	5	4	3	2	1	0
ID	A A A A A A A A																															
Reset 0x00000000	0 0																															
ID	Acce	Field	Value	ID	Value	Description																										
A	RW	ORC				Over-read character. Character clocked out in case and over-read of the TXD buffer.																										

6.19.6 Electrical specification

6.19.6.1 SPIM master interface electrical specifications

Symbol	Description	Min.	Typ.	Max.	Units
f _{SPIM}	Bit rates for SPIM ²⁴			g ²⁵	Mbps
t _{SPIM,START}	Time from START task to transmission started	µs

6.19.6.2 Serial Peripheral Interface Master (SPIM) timing specifications

Symbol	Description	Min.	Typ.	Max.	Units
t _{SPIM,CSCK}	SCK period	ns
t _{SPIM,RSCK,LD}	SCK rise time, standard drive ^a			t _{RF,25pF}	
t _{SPIM,RSCK,HD}	SCK rise time, high drive ^a			t _{HRE,25pF}	
t _{SPIM,FSCK,LD}	SCK fall time, standard drive ^a			t _{RF,25pF}	
t _{SPIM,FSCK,HD}	SCK fall time, high drive ^a			t _{HRE,25pF}	
t _{SPIM,WHSCK}	SCK high time ^a	(0.5*t _{CSCK} - t _{RSCK})			
t _{SPIM,WLSCK}	SCK low time ^a	(0.5*t _{CSCK} - t _{FSCK})			
t _{SPIM,SUMI}	MISO to CLK edge setup time	19			ns
t _{SPIM,HMI}	CLK edge to MISO hold time	18			ns
t _{SPIM,VMO}	CLK edge to MOSI valid			59	ns
t _{SPIM,HMO}	MOSI hold time after CLK edge	20			ns

²⁴ High bit rates may require GPIOs to be set as High Drive, see GPIO chapter for more details.

²⁵ The actual maximum data rate depends on the slave's CLK to MISO and MOSI setup and hold timings.

^a At 25pF load, including GPIO pin capacitance, see GPIO spec.

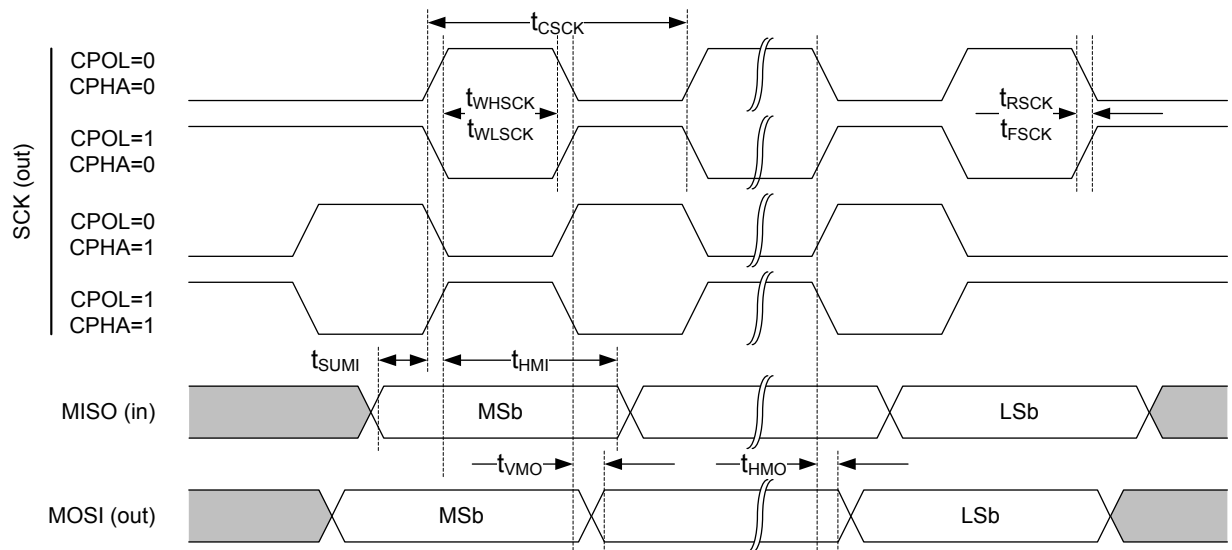

Figure 103: SPIM timing diagram

6.20 SPIS — Serial peripheral interface slave with EasyDMA

SPI slave (SPIS) is implemented with EasyDMA support for ultra low power serial communication from an external SPI master. EasyDMA in conjunction with hardware-based semaphore mechanisms removes all real-time requirements associated with controlling the SPI slave from a low priority CPU execution context.

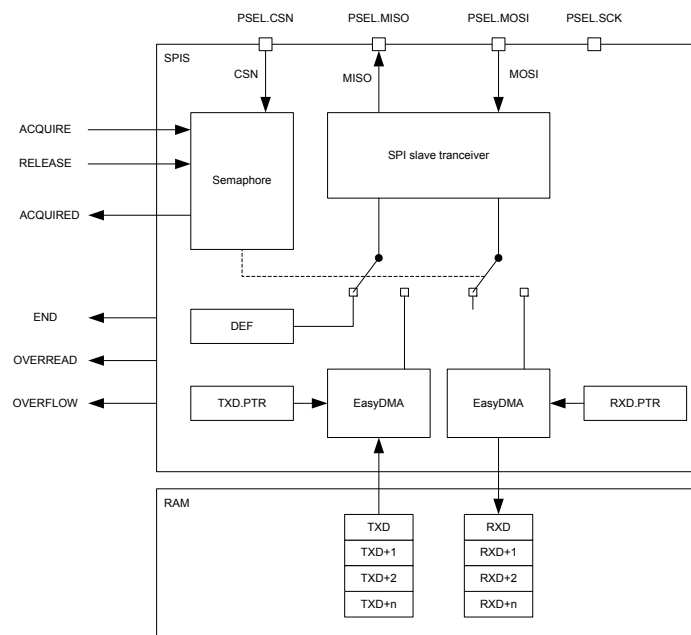

Figure 104: SPI slave

The SPIS supports SPI modes 0 through 3. The CONFIG register allows setting CPOL and CPHA appropriately.

Mode	Clock polarity	Clock phase
	CPOL	CPHA
SPI_MODE0	0 (Active High)	0 (Trailing Edge)
SPI_MODE1	0 (Active High)	1 (Leading Edge)
SPI_MODE2	1 (Active Low)	0 (Trailing Edge)
SPI_MODE3	1 (Active Low)	1 (Leading Edge)

Table 83: SPI modes

6.20.1 Shared resources

The SPI slave shares registers and other resources with other peripherals that have the same ID as the SPI slave. Therefore, you must disable all peripherals that have the same ID as the SPI slave before the SPI slave can be configured and used.

Disabling a peripheral that has the same ID as the SPI slave will not reset any of the registers that are shared with the SPI slave. It is important to configure all relevant SPI slave registers explicitly to secure that it operates correctly.

The Instantiation table in [Instantiation](#) on page 19 shows which peripherals have the same ID as the SPI slave.

6.20.2 EasyDMA

The SPIS implements EasyDMA for accessing RAM without CPU involvement.

The SPIS peripheral implements the following EasyDMA channels:

Channel	Type	Register Cluster
TXD	READER	TXD
RXD	WRITER	RXD

Table 84: SPIS EasyDMA Channels

For detailed information regarding the use of EasyDMA, see [EasyDMA](#) on page 36.

If RXD.MAXCNT is larger than TXD.MAXCNT, the remaining transmitted bytes will contain the value defined in the ORC register.

The END event indicates that EasyDMA has finished accessing the buffer in RAM.

6.20.3 SPI slave operation

SPI slave uses two memory pointers, RXD.PTR and TXD.PTR, that point to the RXD buffer (receive buffer) and TXD buffer (transmit buffer) respectively. Since these buffers are located in RAM, which can be accessed by both the SPI slave and the CPU, a hardware based semaphore mechanism is implemented to enable safe sharing.

See [SPI transaction when shortcut between END and ACQUIRE is enabled](#) on page 277.

Before the CPU can safely update the RXD.PTR and TXD.PTR pointers it must first acquire the SPI semaphore. The CPU can acquire the semaphore by triggering the ACQUIRE task and then receiving the ACQUIRED event. When the CPU has updated the RXD.PTR and TXD.PTR pointers the CPU must release the semaphore before the SPI slave will be able to acquire it. The CPU releases the semaphore by triggering the RELEASE task. This is illustrated in [SPI transaction when shortcut between END and ACQUIRE is enabled](#) on page 277. Triggering the RELEASE task when the semaphore is not granted to the CPU will have no effect.

The semaphore mechanism does not, at any time, prevent the CPU from performing read or write access to the RXD.PTR register, the TXD.PTR registers, or the RAM that these pointers are pointing to. The semaphore is only telling when these can be updated by the CPU so that safe sharing is achieved.

The semaphore is by default assigned to the CPU after the SPI slave is enabled. No ACQUIRED event will be generated for this initial semaphore handover. An ACQUIRED event will be generated immediately if the ACQUIRE task is triggered while the semaphore is assigned to the CPU.

The SPI slave will try to acquire the semaphore when CSN goes low. If the SPI slave does not manage to acquire the semaphore at this point, the transaction will be ignored. This means that all incoming data on MOSI will be discarded, and the DEF (default) character will be clocked out on the MISO line throughout the whole transaction. This will also be the case even if the semaphore is released by the CPU during the transaction. In case of a race condition where the CPU and the SPI slave try to acquire the semaphore at the same time, as illustrated in lifeline item 2 in [SPI transaction when shortcut between END and ACQUIRE is enabled](#) on page 277, the semaphore will be granted to the CPU.

If the SPI slave acquires the semaphore, the transaction will be granted. The incoming data on MOSI will be stored in the RXD buffer and the data in the TXD buffer will be clocked out on MISO.

When a granted transaction is completed and CSN goes high, the SPI slave will automatically release the semaphore and generate the END event.

As long as the semaphore is available the SPI slave can be granted multiple transactions one after the other. If the CPU is not able to reconfigure the TXD.PTR and RXD.PTR between granted transactions, the same TX data will be clocked out and the RX buffers will be overwritten. To prevent this from happening, the END_ACQUIRE shortcut can be used. With this shortcut enabled the semaphore will be handed over to the CPU automatically after the granted transaction has completed, giving the CPU the ability to update the TXPTR and RXPTR between every granted transaction.

If the CPU tries to acquire the semaphore while it is assigned to the SPI slave, an immediate handover will not be granted. However, the semaphore will be handed over to the CPU as soon as the SPI slave has released the semaphore after the granted transaction is completed. If the END_ACQUIRE shortcut is enabled and the CPU has triggered the ACQUIRE task during a granted transaction, only one ACQUIRE request will be served following the END event.

The MAXRX register specifies the maximum number of bytes the SPI slave can receive in one granted transaction. If the SPI slave receives more than MAXRX number of bytes, an OVERFLOW will be indicated in the STATUS register and the incoming bytes will be discarded.

The MAXTX parameter specifies the maximum number of bytes the SPI slave can transmit in one granted transaction. If the SPI slave is forced to transmit more than MAXTX number of bytes, an OVERREAD will be indicated in the STATUS register and the ORC character will be clocked out.

The RXD.AMOUNT and TXD.AMOUNT registers are updated when a granted transaction is completed. The TXD.AMOUNT register indicates how many bytes were read from the TX buffer in the last transaction, that is, ORC (over-read) characters are not included in this number. Similarly, the RXD.AMOUNT register indicates how many bytes were written into the RX buffer in the last transaction.

The ENDRX event is generated when the RX buffer has been filled.

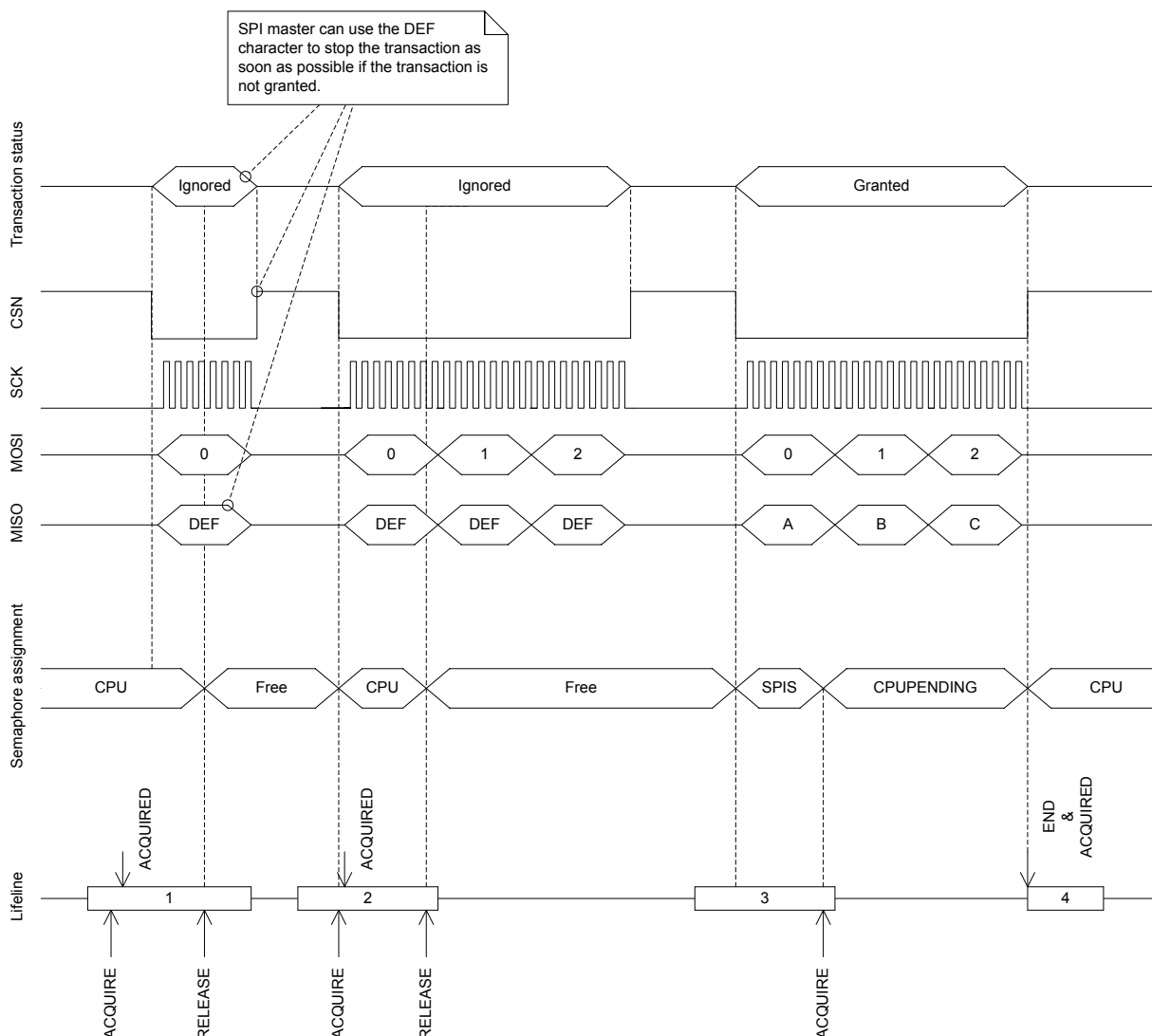

Figure 105: SPI transaction when shortcut between END and ACQUIRE is enabled

6.20.4 Pin configuration

The CSN, SCK, MOSI, and MISO signals associated with the SPI slave are mapped to physical pins according to the configuration specified in the PSEL.CSN, PSEL.SCK, PSEL.MOSI, and PSEL.MISO registers respectively. If the CONNECT field of any of these registers is set to Disconnected, the associated SPI slave signal will not be connected to any physical pins.

The PSEL.CSN, PSEL.SCK, PSEL.MOSI, and PSEL.MISO registers and their configurations are only used as long as the SPI slave is enabled, and retained only as long as the device is in System ON mode, see [POWER — Power supply](#) on page 49 chapter for more information about power modes. When the peripheral is disabled, the pins will behave as regular GPIOs, and use the configuration in their respective OUT bit field and PIN_CNFG[n] register. PSEL.CSN, PSEL.SCK, PSEL.MOSI, and PSEL.MISO must only be configured when the SPI slave is disabled.

To secure correct behavior in the SPI slave, the pins used by the SPI slave must be configured in the GPIO peripheral as described in [GPIO configuration before enabling peripheral](#) on page 278 before enabling the SPI slave. This is to secure that the pins used by the SPI slave are driven correctly if the SPI slave itself is temporarily disabled, or if the device temporarily enters System OFF. This configuration must be retained in the GPIO for the selected I/Os as long as the SPI slave is to be recognized by an external SPI master.

The MISO line is set in high impedance as long as the SPI slave is not selected with CSN.

Only one peripheral can be assigned to drive a particular GPIO pin at a time. Failing to do so may result in unpredictable behavior.

SPI signal	SPI pin	Direction	Output value	Comment
CSN	As specified in PSEL.CSN	Input	Not applicable	
SCK	As specified in PSEL.SCK	Input	Not applicable	
MOSI	As specified in PSEL.MOSI	Input	Not applicable	
MISO	As specified in PSEL.MISO	Input	Not applicable	Emulates that the SPI slave is not selected.

Table 85: GPIO configuration before enabling peripheral

6.20.5 Registers

Base address	Peripheral	Instance	Description	Configuration
0x40004000	SPIS	SPIS0	SPI slave	

Table 86: Instances

Register	Offset	Description	
TASKS_ACQUIRE	0x024	Acquire SPI semaphore	
TASKS_RELEASE	0x028	Release SPI semaphore, enabling the SPI slave to acquire it	
EVENTS_END	0x104	Granted transaction completed	
EVENTS_ENDRX	0x110	End of RXD buffer reached	
EVENTS_ACQUIRED	0x128	Semaphore acquired	
SHORTS	0x200	Shortcuts between local events and tasks	
INTENSET	0x304	Enable interrupt	
INTENCLR	0x308	Disable interrupt	
SEMSTAT	0x400	Semaphore status register	
STATUS	0x440	Status from last transaction	
ENABLE	0x500	Enable SPI slave	
PSEL.SCK	0x508	Pin select for SCK	
PSEL.MISO	0x50C	Pin select for MISO signal	
PSEL.MOSI	0x510	Pin select for MOSI signal	
PSEL.CSN	0x514	Pin select for CSN signal	
PSELSCK	0x508	Pin select for SCK	Deprecated
PSELMISO	0x50C	Pin select for MISO	Deprecated
PSELMOSI	0x510	Pin select for MOSI	Deprecated
PSELCSN	0x514	Pin select for CSN	Deprecated
RXDPTR	0x534	RXD data pointer	Deprecated
MAXRX	0x538	Maximum number of bytes in receive buffer	Deprecated
AMOUNTRX	0x53C	Number of bytes received in last granted transaction	Deprecated
RXD.PTR	0x534	RXD data pointer	
RXD.MAXCNT	0x538	Maximum number of bytes in receive buffer	
RXD.AMOUNT	0x53C	Number of bytes received in last granted transaction	
RXD.LIST	0x540	EasyDMA list type	
TXDPTR	0x544	TXD data pointer	Deprecated
MAXTX	0x548	Maximum number of bytes in transmit buffer	Deprecated
AMOUNTTX	0x54C	Number of bytes transmitted in last granted transaction	Deprecated
TXD.PTR	0x544	TXD data pointer	
TXD.MAXCNT	0x548	Maximum number of bytes in transmit buffer	
TXD.AMOUNT	0x54C	Number of bytes transmitted in last granted transaction	
TXD.LIST	0x550	EasyDMA list type	
CONFIG	0x554	Configuration register	

Register	Offset	Description
DEF	0x55C	Default character. Character clocked out in case of an ignored transaction.
ORC	0x5C0	Over-read character

Table 87: Register overview

6.20.5.1 TASKS_ACQUIRE

Address offset: 0x024

Acquire SPI semaphore

Bit number	31 30 29 28 27 26 25 24 23 22 21 20 19 18 17 16 15 14 13 12 11 10 9 8 7 6 5 4 3 2 1 0																														
ID	A																														
Reset 0x00000000	0 0																														
ID	Acce Field	Value ID	Value	Description																											
A	W TASKS_ACQUIRE			Acquire SPI semaphore																											
		Trigger	1	Trigger task																											

6.20.5.2 TASKS_RELEASE

Address offset: 0x028

Release SPI semaphore, enabling the SPI slave to acquire it

Bit number	31 30 29 28 27 26 25 24 23 22 21 20 19 18 17 16 15 14 13 12 11 10 9 8 7 6 5 4 3 2 1 0																														
ID	A																														
Reset 0x00000000	0 0																														
ID	Acce Field	Value ID	Value	Description																											
A	W TASKS_RELEASE			Release SPI semaphore, enabling the SPI slave to acquire it																											
		Trigger	1	Trigger task																											

6.20.5.3 EVENTS_END

Address offset: 0x104

Granted transaction completed

Bit number	31 30 29 28 27 26 25 24 23 22 21 20 19 18 17 16 15 14 13 12 11 10 9 8 7 6 5 4 3 2 1 0																														
ID	A																														
Reset 0x00000000	0 0																														
ID	Acce Field	Value ID	Value	Description																											
A	RW EVENTS_END			Granted transaction completed																											
		NotGenerated	0	Event not generated																											
		Generated	1	Event generated																											

6.20.5.4 EVENTS_ENDRX

Address offset: 0x110

End of RXD buffer reached

Bit number	31	30	29	28	27	26	25	24	23	22	21	20	19	18	17	16	15	14	13	12	11	10	9	8	7	6	5	4	3	2	1	0
ID																																A
Reset 0x00000000	0 0																															
ID	Acce Field	Value ID	Value	Description																												
A	RW EVENTS_ENDRX			End of RXD buffer reached																												
		NotGenerated	0	Event not generated																												
		Generated	1	Event generated																												

6.20.5.5 EVENTS_ACQUIRED

Address offset: 0x128

Semaphore acquired

Bit number	31	30	29	28	27	26	25	24	23	22	21	20	19	18	17	16	15	14	13	12	11	10	9	8	7	6	5	4	3	2	1	0
ID																																A
Reset 0x00000000	0 0																															
ID	Acce Field	Value ID	Value	Description																												
A	RW EVENTS_ACQUIRED			Semaphore acquired																												
		NotGenerated	0	Event not generated																												
		Generated	1	Event generated																												

6.20.5.6 SHORTS

Address offset: 0x200

Shortcuts between local events and tasks

Bit number	31	30	29	28	27	26	25	24	23	22	21	20	19	18	17	16	15	14	13	12	11	10	9	8	7	6	5	4	3	2	1	0
ID																																A
Reset 0x00000000	0 0																															
ID	Acce Field	Value ID	Value	Description																												
A	RW END_ACQUIRE			Shortcut between event END and task ACQUIRE																												
		Disabled	0	Disable shortcut																												
		Enabled	1	Enable shortcut																												

6.20.5.7 INTENSET

Address offset: 0x304

Enable interrupt

Bit number	31	30	29	28	27	26	25	24	23	22	21	20	19	18	17	16	15	14	13	12	11	10	9	8	7	6	5	4	3	2	1	0
ID																												C	B	A		
Reset 0x00000000	0 0																															
ID	Acce Field	Value ID	Value	Description																												
A	RW END			Write '1' to enable interrupt for event END																												
		Set	1	Enable																												
		Disabled	0	Read: Disabled																												
		Enabled	1	Read: Enabled																												
B	RW ENDRX			Write '1' to enable interrupt for event ENDRX																												
		Set	1	Enable																												
		Disabled	0	Read: Disabled																												
		Enabled	1	Read: Enabled																												
C	RW ACQUIRED			Write '1' to enable interrupt for event ACQUIRED																												

Bit number	31	30	29	28	27	26	25	24	23	22	21	20	19	18	17	16	15	14	13	12	11	10	9	8	7	6	5	4	3	2	1	0
ID																									C	B			A			
Reset 0x00000000	0	0	0	0	0	0	0	0	0	0	0	0	0	0	0	0	0	0	0	0	0	0	0	0	0	0	0	0	0	0	0	0
ID	Acce	Field	Value ID	Value	Description																											
			Set	1	Enable																											
			Disabled	0	Read: Disabled																											
			Enabled	1	Read: Enabled																											

6.20.5.8 INTENCLR

Address offset: 0x308

Disable interrupt

Bit number	31	30	29	28	27	26	25	24	23	22	21	20	19	18	17	16	15	14	13	12	11	10	9	8	7	6	5	4	3	2	1	0
ID																									C	B			A			
Reset 0x00000000	0	0	0	0	0	0	0	0	0	0	0	0	0	0	0	0	0	0	0	0	0	0	0	0	0	0	0	0	0	0	0	
ID	Acce	Field	Value ID	Value	Description																											
A	RW	END			Write '1' to disable interrupt for event END																											
			Clear	1	Disable																											
			Disabled	0	Read: Disabled																											
			Enabled	1	Read: Enabled																											
B	RW	ENDRX			Write '1' to disable interrupt for event ENDRX																											
			Clear	1	Disable																											
			Disabled	0	Read: Disabled																											
			Enabled	1	Read: Enabled																											
C	RW	ACQUIRED			Write '1' to disable interrupt for event ACQUIRED																											
			Clear	1	Disable																											
			Disabled	0	Read: Disabled																											
			Enabled	1	Read: Enabled																											

6.20.5.9 SEMSTAT

Address offset: 0x400

Semaphore status register

Bit number	31	30	29	28	27	26	25	24	23	22	21	20	19	18	17	16	15	14	13	12	11	10	9	8	7	6	5	4	3	2	1	0
ID																									A	A						
Reset 0x00000001	0	0	0	0	0	0	0	0	0	0	0	0	0	0	0	0	0	0	0	0	0	0	0	0	0	0	0	0	0	0	0	1
ID	Acce	Field	Value ID	Value	Description																											
A	R	SEMSTAT			Semaphore status																											
			Free	0	Semaphore is free																											
			CPU	1	Semaphore is assigned to CPU																											
			SPIS	2	Semaphore is assigned to SPI slave																											
			CPUPending	3	Semaphore is assigned to SPI but a handover to the CPU is pending																											

6.20.5.10 STATUS

Address offset: 0x440

Status from last transaction

Individual bits are cleared by writing a '1' to the bits that shall be cleared

Bit number	31 30 29 28 27 26 25 24 23 22 21 20 19 18 17 16 15 14 13 12 11 10 9 8 7 6 5 4 3 2 1 0																															
ID																															B	A
Reset 0x00000000	0 0																															
ID	Acce Field	Value ID	Value	Description																												
A	RW OVERREAD			TX buffer over-read detected, and prevented																												
		NotPresent	0	Read: error not present																												
		Present	1	Read: error present																												
		Clear	1	Write: clear error on writing '1'																												
B	RW OVERFLOW			RX buffer overflow detected, and prevented																												
		NotPresent	0	Read: error not present																												
		Present	1	Read: error present																												
		Clear	1	Write: clear error on writing '1'																												

6.20.5.11 ENABLE

Address offset: 0x500

Enable SPI slave

Bit number	31 30 29 28 27 26 25 24 23 22 21 20 19 18 17 16 15 14 13 12 11 10 9 8 7 6 5 4 3 2 1 0																																	
ID																															A	A	A	A
Reset 0x00000000	0 0																																	
ID	Acce Field	Value ID	Value	Description																														
A	RW ENABLE			Enable or disable SPI slave																														
		Disabled	0	Disable SPI slave																														
		Enabled	2	Enable SPI slave																														

6.20.5.12 PSEL.SCK

Address offset: 0x508

Pin select for SCK

Bit number	31 30 29 28 27 26 25 24 23 22 21 20 19 18 17 16 15 14 13 12 11 10 9 8 7 6 5 4 3 2 1 0																																		
ID																															C	A	A	A	A
Reset 0xFFFFFFFF	1 1																																		
ID	Acce Field	Value ID	Value	Description																															
A	RW PIN		[0..31]	Pin number																															
C	RW CONNECT			Connection																															
		Disconnected	1	Disconnect																															
		Connected	0	Connect																															

6.20.5.13 PSEL.MISO

Address offset: 0x50C

Pin select for MISO signal

Bit number	31 30 29 28 27 26 25 24 23 22 21 20 19 18 17 16 15 14 13 12 11 10 9 8 7 6 5 4 3 2 1 0																														
ID	C																												A A A A		
Reset 0xFFFFFFFF	1 1																														
ID	Acce Field	Value ID	Value	Description																											
A	RW PIN		[0..31]	Pin number																											
C	RW CONNECT			Connection																											
		Disconnected	1	Disconnect																											
		Connected	0	Connect																											

6.20.5.14 PSEL.MOSI

Address offset: 0x510

Pin select for MOSI signal

Bit number	31 30 29 28 27 26 25 24 23 22 21 20 19 18 17 16 15 14 13 12 11 10 9 8 7 6 5 4 3 2 1 0																														
ID	C																												A A A A		
Reset 0xFFFFFFFF	1 1																														
ID	Acce Field	Value ID	Value	Description																											
A	RW PIN		[0..31]	Pin number																											
C	RW CONNECT			Connection																											
		Disconnected	1	Disconnect																											
		Connected	0	Connect																											

6.20.5.15 PSEL.CSN

Address offset: 0x514

Pin select for CSN signal

Bit number	31 30 29 28 27 26 25 24 23 22 21 20 19 18 17 16 15 14 13 12 11 10 9 8 7 6 5 4 3 2 1 0																														
ID	C																												A A A A		
Reset 0xFFFFFFFF	1 1																														
ID	Acce Field	Value ID	Value	Description																											
A	RW PIN		[0..31]	Pin number																											
C	RW CONNECT			Connection																											
		Disconnected	1	Disconnect																											
		Connected	0	Connect																											

6.20.5.16 PSEL.SCK (Deprecated)

Address offset: 0x508

Pin select for SCK

Bit number	31 30 29 28 27 26 25 24 23 22 21 20 19 18 17 16 15 14 13 12 11 10 9 8 7 6 5 4 3 2 1 0																														
ID	A A																														
Reset 0xFFFFFFFF	1 1																														
ID	Acce Field	Value ID	Value	Description																											
A	RW PSEL.SCK		[0..31]	Pin number configuration for SPI SCK signal																											
		Disconnected	0xFFFFFFFF	Disconnect																											

6.20.5.17 PSEL.MISO (Deprecated)

Address offset: 0x50C

Pin select for MISO

Bit number	31 30 29 28 27 26 25 24 23 22 21 20 19 18 17 16 15 14 13 12 11 10 9 8 7 6 5 4 3 2 1 0																															
ID	A A																															
Reset 0xFFFFFFFF	1 1																															
ID	Acce Field	Value ID	Value	Description																												
A	RW PSELMISO		[0..31]	Pin number configuration for SPI MISO signal																												
		Disconnected	0xFFFFFFFF	Disconnect																												

6.20.5.18 PSELMOSI (Deprecated)

Address offset: 0x510

Pin select for MOSI

Bit number	31 30 29 28 27 26 25 24 23 22 21 20 19 18 17 16 15 14 13 12 11 10 9 8 7 6 5 4 3 2 1 0																															
ID	A A																															
Reset 0xFFFFFFFF	1 1																															
ID	Acce Field	Value ID	Value	Description																												
A	RW PSELMOSI		[0..31]	Pin number configuration for SPI MOSI signal																												
		Disconnected	0xFFFFFFFF	Disconnect																												

6.20.5.19 PSELCSN (Deprecated)

Address offset: 0x514

Pin select for CSN

Bit number	31 30 29 28 27 26 25 24 23 22 21 20 19 18 17 16 15 14 13 12 11 10 9 8 7 6 5 4 3 2 1 0																															
ID	A A																															
Reset 0xFFFFFFFF	1 1																															
ID	Acce Field	Value ID	Value	Description																												
A	RW PSELCSN		[0..31]	Pin number configuration for SPI CSN signal																												
		Disconnected	0xFFFFFFFF	Disconnect																												

6.20.5.20 RXDPTR (Deprecated)

Address offset: 0x534

RXD data pointer

Bit number	31 30 29 28 27 26 25 24 23 22 21 20 19 18 17 16 15 14 13 12 11 10 9 8 7 6 5 4 3 2 1 0																															
ID	A A																															
Reset 0x00000000	0 0																															
ID	Acce Field	Value ID	Value	Description																												
A	RW RXDPTR			RXD data pointer																												

Note: See the memory chapter for details about which memories are available for EasyDMA.

6.20.5.21 MAXRX (Deprecated)

Address offset: 0x538

Maximum number of bytes in receive buffer

Bit number	31	30	29	28	27	26	25	24	23	22	21	20	19	18	17	16	15	14	13	12	11	10	9	8	7	6	5	4	3	2	1	0
ID	A A																															
Reset	0x00000000																															
Reset	0 0																															
ID	Acce	Field	Value ID	Value	Description																											
A	RW	MAXRX		[1..0x3FF]	Maximum number of bytes in receive buffer																											

6.20.5.22 AMOUNTRX (Deprecated)

Address offset: 0x53C

Number of bytes received in last granted transaction

Bit number	31	30	29	28	27	26	25	24	23	22	21	20	19	18	17	16	15	14	13	12	11	10	9	8	7	6	5	4	3	2	1	0
ID	A A																															
Reset	0x00000000																															
Reset	0 0																															
ID	Acce	Field	Value ID	Value	Description																											
A	R	AMOUNTRX		[1..0x3FF]	Number of bytes received in the last granted transaction																											

6.20.5.23 RXD.PTR

Address offset: 0x534

RXD data pointer

Bit number	31	30	29	28	27	26	25	24	23	22	21	20	19	18	17	16	15	14	13	12	11	10	9	8	7	6	5	4	3	2	1	0
ID	A A																															
Reset	0x00000000																															
Reset	0 0																															
ID	Acce	Field	Value ID	Value	Description																											
A	RW	PTR			RXD data pointer																											

Note: See the memory chapter for details about which memories are available for EasyDMA.

6.20.5.24 RXD.MAXCNT

Address offset: 0x538

Maximum number of bytes in receive buffer

Bit number	31	30	29	28	27	26	25	24	23	22	21	20	19	18	17	16	15	14	13	12	11	10	9	8	7	6	5	4	3	2	1	0
ID	A A																															
Reset	0x00000000																															
Reset	0 0																															
ID	Acce	Field	Value ID	Value	Description																											
A	RW	MAXCNT		[1..0x3FF]	Maximum number of bytes in receive buffer																											

6.20.5.25 RXD.AMOUNT

Address offset: 0x53C

Number of bytes received in last granted transaction

Bit number	31	30	29	28	27	26	25	24	23	22	21	20	19	18	17	16	15	14	13	12	11	10	9	8	7	6	5	4	3	2	1	0																								
ID																											A	A	A	A	A	A	A	A	A	A	A	A	A	A	A	A	A	A	A	A	A	A	A	A	A	A	A	A	A	A
Reset 0x00000000	0																										0	0	0	0	0	0	0	0	0	0	0	0	0	0	0	0	0	0	0	0	0	0	0	0	0	0	0	0	0	0
ID	Acce Field	Value ID	Value	Description																																																				
A	R	AMOUNT	[1..0x3FF]	Number of bytes received in the last granted transaction																																																				

6.20.5.26 RXD.LIST

Address offset: 0x540

EasyDMA list type

Bit number	31	30	29	28	27	26	25	24	23	22	21	20	19	18	17	16	15	14	13	12	11	10	9	8	7	6	5	4	3	2	1	0																								
ID																											A	A																												
Reset 0x00000000	0																										0	0	0	0	0	0	0	0	0	0	0	0	0	0	0	0	0	0	0	0	0	0	0	0	0	0	0	0	0	0
ID	Acce Field	Value ID	Value	Description																																																				
A	RW	LIST		List type																																																				
		Disabled	0	Disable EasyDMA list																																																				
		ArrayList	1	Use array list																																																				

6.20.5.27 TXDPTR (Deprecated)

Address offset: 0x544

TXD data pointer

Bit number	31	30	29	28	27	26	25	24	23	22	21	20	19	18	17	16	15	14	13	12	11	10	9	8	7	6	5	4	3	2	1	0																								
ID	A	A	A	A	A	A	A	A	A	A	A	A	A	A	A	A	A	A	A	A	A	A	A	A	A	A	A	A	A	A	A	A																								
Reset 0x00000000	0																										0	0	0	0	0	0	0	0	0	0	0	0	0	0	0	0	0	0	0	0	0	0	0	0	0	0	0	0	0	0
ID	Acce Field	Value ID	Value	Description																																																				
A	RW	TXDPTR		TXD data pointer																																																				

Note: See the memory chapter for details about which memories are available for EasyDMA.

6.20.5.28 MAXTX (Deprecated)

Address offset: 0x548

Maximum number of bytes in transmit buffer

Bit number	31	30	29	28	27	26	25	24	23	22	21	20	19	18	17	16	15	14	13	12	11	10	9	8	7	6	5	4	3	2	1	0																								
ID																											A	A	A	A	A	A	A	A	A	A	A	A	A	A	A	A	A	A	A	A	A	A	A	A	A	A	A	A	A	A
Reset 0x00000000	0																										0	0	0	0	0	0	0	0	0	0	0	0	0	0	0	0	0	0	0	0	0	0	0	0	0	0	0	0	0	0
ID	Acce Field	Value ID	Value	Description																																																				
A	RW	MAXTX	[1..0x3FF]	Maximum number of bytes in transmit buffer																																																				

6.20.5.29 AMOUNTTX (Deprecated)

Address offset: 0x54C

Number of bytes transmitted in last granted transaction

Bit number	31	30	29	28	27	26	25	24	23	22	21	20	19	18	17	16	15	14	13	12	11	10	9	8	7	6	5	4	3	2	1	0
ID	A A																															
Reset	0x00000000																															
	0 0																															
ID	Acce Field	Value ID	Value	Description																												
A	R	AMOUNTTX	[1..0x3FF]	Number of bytes transmitted in last granted transaction																												

6.20.5.30 TXD.PTR

Address offset: 0x544

TXD data pointer

Bit number	31	30	29	28	27	26	25	24	23	22	21	20	19	18	17	16	15	14	13	12	11	10	9	8	7	6	5	4	3	2	1	0
ID	A A																															
Reset	0x00000000																															
	0 0																															
ID	Acce Field	Value ID	Value	Description																												
A	RW	PTR		TXD data pointer																												

Note: See the memory chapter for details about which memories are available for EasyDMA.

6.20.5.31 TXD.MAXCNT

Address offset: 0x548

Maximum number of bytes in transmit buffer

Bit number	31	30	29	28	27	26	25	24	23	22	21	20	19	18	17	16	15	14	13	12	11	10	9	8	7	6	5	4	3	2	1	0
ID	A A																															
Reset	0x00000000																															
	0 0																															
ID	Acce Field	Value ID	Value	Description																												
A	RW	MAXCNT	[1..0x3FF]	Maximum number of bytes in transmit buffer																												

6.20.5.32 TXD.AMOUNT

Address offset: 0x54C

Number of bytes transmitted in last granted transaction

Bit number	31	30	29	28	27	26	25	24	23	22	21	20	19	18	17	16	15	14	13	12	11	10	9	8	7	6	5	4	3	2	1	0
ID	A A																															
Reset	0x00000000																															
	0 0																															
ID	Acce Field	Value ID	Value	Description																												
A	R	AMOUNT	[1..0x3FF]	Number of bytes transmitted in last granted transaction																												

6.20.5.33 TXD.LIST

Address offset: 0x550

EasyDMA list type

Bit number	31 30 29 28 27 26 25 24 23 22 21 20 19 18 17 16 15 14 13 12 11 10 9 8 7 6 5 4 3 2 1 0																															
ID																															A	A
Reset 0x00000000	0 0																															
ID	Acce Field	Value ID	Value	Description																												
A	RW LIST			List type																												
		Disabled	0	Disable EasyDMA list																												
		ArrayList	1	Use array list																												

6.20.5.34 CONFIG

Address offset: 0x554

Configuration register

Bit number	31 30 29 28 27 26 25 24 23 22 21 20 19 18 17 16 15 14 13 12 11 10 9 8 7 6 5 4 3 2 1 0																																
ID																															C	B	A
Reset 0x00000000	0 0																																
ID	Acce Field	Value ID	Value	Description																													
A	RW ORDER			Bit order																													
		MsbFirst	0	Most significant bit shifted out first																													
		LsbFirst	1	Least significant bit shifted out first																													
B	RW CPHA			Serial clock (SCK) phase																													
		Leading	0	Sample on leading edge of clock, shift serial data on trailing edge																													
		Trailing	1	Sample on trailing edge of clock, shift serial data on leading edge																													
C	RW CPOL			Serial clock (SCK) polarity																													
		ActiveHigh	0	Active high																													
		ActiveLow	1	Active low																													

6.20.5.35 DEF

Address offset: 0x55C

Default character. Character clocked out in case of an ignored transaction.

Bit number	31 30 29 28 27 26 25 24 23 22 21 20 19 18 17 16 15 14 13 12 11 10 9 8 7 6 5 4 3 2 1 0																																				
ID																															A	A	A	A	A	A	A
Reset 0x00000000	0 0																																				
ID	Acce Field	Value ID	Value	Description																																	
A	RW DEF			Default character. Character clocked out in case of an ignored transaction.																																	

6.20.5.36 ORC

Address offset: 0x5C0

Over-read character

Bit number	31 30 29 28 27 26 25 24 23 22 21 20 19 18 17 16 15 14 13 12 11 10 9 8 7 6 5 4 3 2 1 0																																				
ID																															A	A	A	A	A	A	A
Reset 0x00000000	0 0																																				
ID	Acce Field	Value ID	Value	Description																																	
A	RW ORC			Over-read character. Character clocked out after an over-read of the transmit buffer.																																	

6.20.6 Electrical specification

6.20.6.1 SPIS slave interface electrical specifications

Symbol	Description	Min.	Typ.	Max.	Units
f_{SPIS}	Bit rates for SPIS ²⁶			8 ²⁷	Mbps
$t_{\text{SPIS,START}}$	Time from RELEASE task to receive/transmit (CSN active)	µs

6.20.6.2 Serial Peripheral Interface Slave (SPIS) timing specifications

Symbol	Description	Min.	Typ.	Max.	Units
$t_{\text{SPIS,CCKIN}}$	SCK input period	ns
$t_{\text{SPIS,RFCKIN}}$	SCK input rise/fall time			30	ns
$t_{\text{SPIS,WHCKIN}}$	SCK input high time	30			ns
$t_{\text{SPIS,WLCKIN}}$	SCK input low time	30			ns
$t_{\text{SPIS,SUCSN}}$	CSN to CLK setup time	ns
$t_{\text{SPIS,HCSN}}$	CLK to CSN hold time	2000			ns
$t_{\text{SPIS,ASA}}$	CSN to MISO driven	ns
$t_{\text{SPIS,ASO}}$	CSN to MISO valid ^a			1000	ns
$t_{\text{SPIS,DISSO}}$	CSN to MISO disabled ^a			68	ns
$t_{\text{SPIS,CWH}}$	CSN inactive time	300			ns
$t_{\text{SPIS,VSO}}$	CLK edge to MISO valid			19	ns
$t_{\text{SPIS,HSD}}$	MISO hold time after CLK edge	18 ²⁸			ns
$t_{\text{SPIS,SUSI}}$	MOSI to CLK edge setup time	59			ns
$t_{\text{SPIS,HSI}}$	CLK edge to MOSI hold time	20			ns

²⁶ High bit rates may require GPIOs to be set as High Drive, see GPIO chapter for more details.

²⁷ The actual maximum data rate depends on the master's CLK to MISO and MOSI setup and hold timings.

^a At 25pF load, including GPIO capacitance, see GPIO spec.

²⁸ This is to ensure compatibility to SPI masters sampling MISO on the same edge as MOSI is output

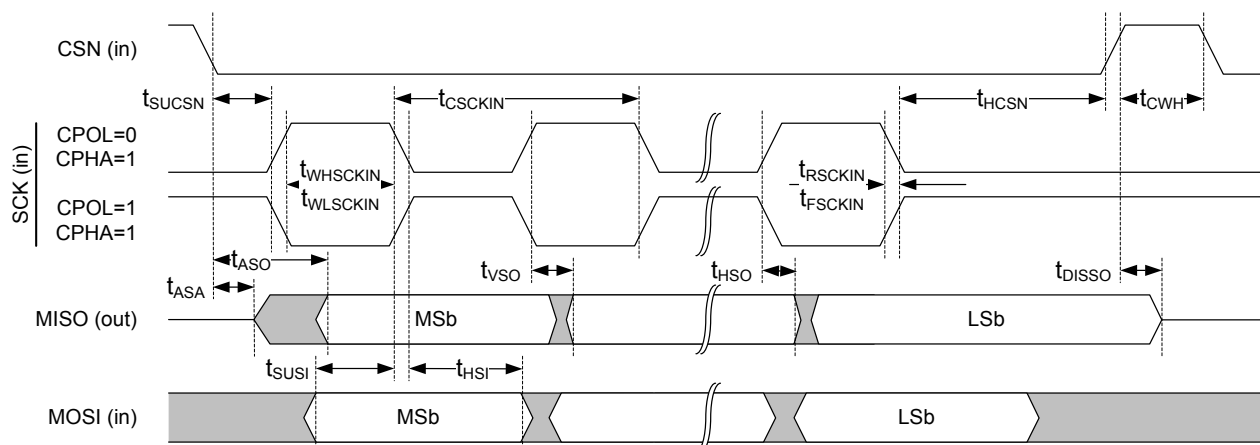
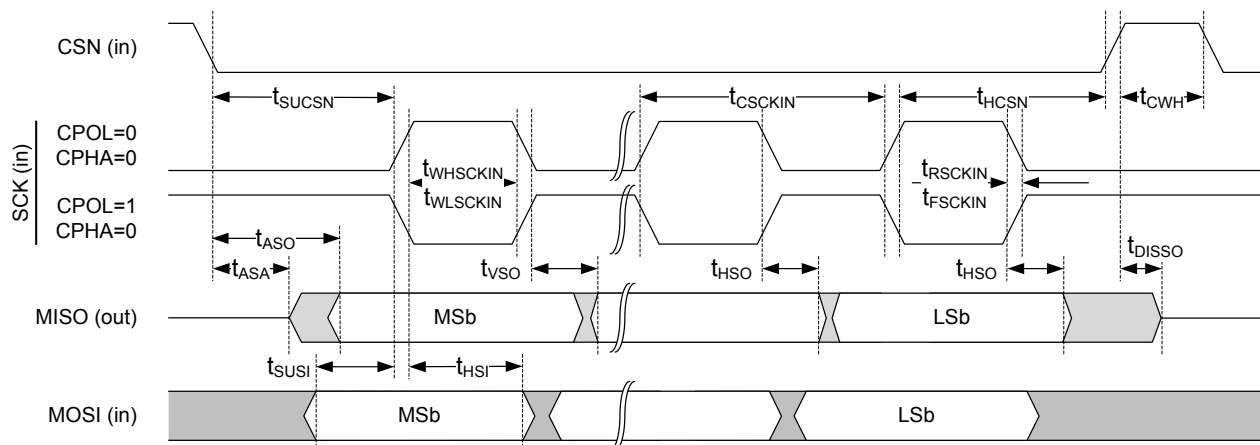

Figure 106: SPIS timing diagram

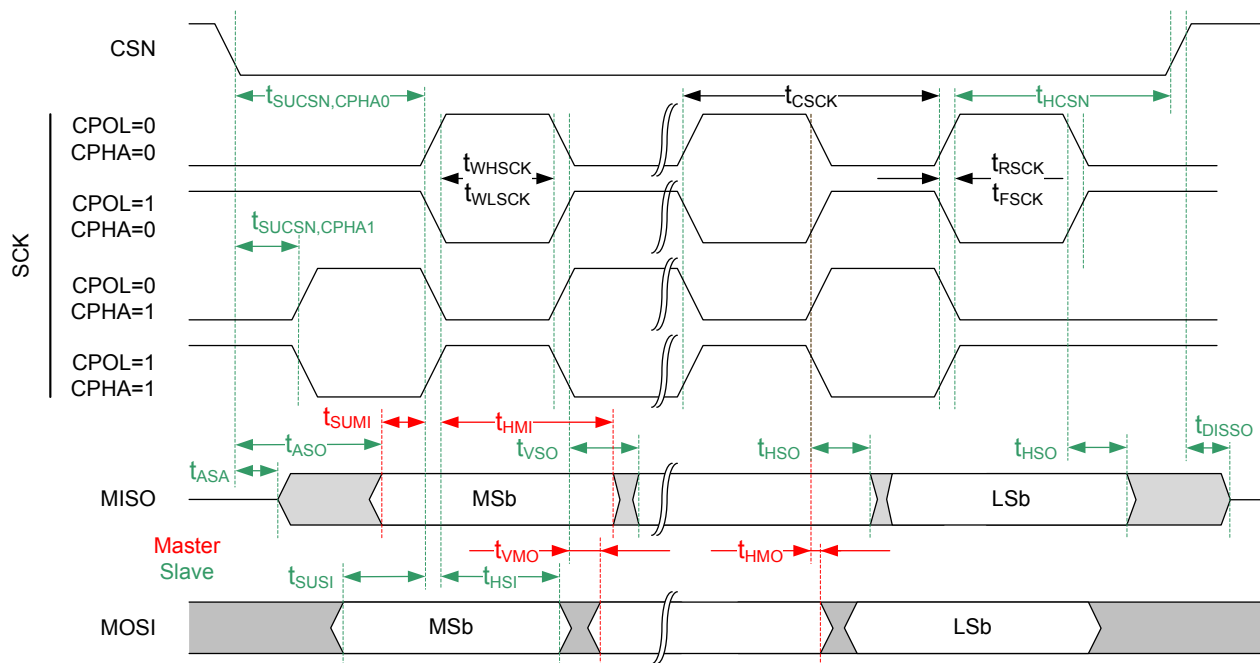

Figure 107: Common SPIM and SPIS timing diagram

6.21 SWI — Software interrupts

A set of interrupts have been reserved for use as software interrupts.

6.21.1 Registers

Base address	Peripheral	Instance	Description	Configuration
0x40014000	SWI	SWI0	Software interrupt 0	
0x40015000	SWI	SWI1	Software interrupt 1	
0x40016000	SWI	SWI2	Software interrupt 2	
0x40017000	SWI	SWI3	Software interrupt 3	
0x40018000	SWI	SWI4	Software interrupt 4	
0x40019000	SWI	SWI5	Software interrupt 5	

Table 88: Instances

6.22 TEMP — Temperature sensor

The temperature sensor measures die temperature over the temperature range of the device. Linearity compensation can be implemented if required by the application.

Listed here are the main features for TEMP:

- Temperature range is greater than or equal to operating temperature of the device
- Resolution is 0.25 degrees

TEMP is started by triggering the START task.

When the temperature measurement is completed, a DATARDY event will be generated and the result of the measurement can be read from the TEMP register.

To achieve the measurement accuracy stated in the electrical specification, the crystal oscillator must be selected as the HFCLK source, see [CLOCK — Clock control](#) on page 62 for more information.

When the temperature measurement is completed, TEMP analog electronics power down to save power.

TEMP only supports one-shot operation, meaning that every TEMP measurement has to be explicitly started using the START task.

6.22.1 Registers

Base address	Peripheral	Instance	Description	Configuration
0x4000C000	TEMP	TEMP	Temperature sensor	

Table 89: Instances

Register	Offset	Description
TASKS_START	0x000	Start temperature measurement
TASKS_STOP	0x004	Stop temperature measurement
EVENTS_DATARDY	0x100	Temperature measurement complete, data ready
INTENSET	0x304	Enable interrupt
INTENCLR	0x308	Disable interrupt
TEMP	0x508	Temperature in °C (0.25° steps)
A0	0x520	Slope of 1st piece wise linear function

Register	Offset	Description
A1	0x524	Slope of 2nd piece wise linear function
A2	0x528	Slope of 3rd piece wise linear function
A3	0x52C	Slope of 4th piece wise linear function
A4	0x530	Slope of 5th piece wise linear function
A5	0x534	Slope of 6th piece wise linear function
B0	0x540	y-intercept of 1st piece wise linear function
B1	0x544	y-intercept of 2nd piece wise linear function
B2	0x548	y-intercept of 3rd piece wise linear function
B3	0x54C	y-intercept of 4th piece wise linear function
B4	0x550	y-intercept of 5th piece wise linear function
B5	0x554	y-intercept of 6th piece wise linear function
T0	0x560	End point of 1st piece wise linear function
T1	0x564	End point of 2nd piece wise linear function
T2	0x568	End point of 3rd piece wise linear function
T3	0x56C	End point of 4th piece wise linear function
T4	0x570	End point of 5th piece wise linear function

Table 90: Register overview

6.22.1.1 TASKS_START

Address offset: 0x000

Start temperature measurement

Bit number	31 30 29 28 27 26 25 24 23 22 21 20 19 18 17 16 15 14 13 12 11 10 9 8 7 6 5 4 3 2 1 0																														
ID	A																														
Reset 0x00000000	0 0																														
ID	Acce Field	Value ID	Value	Description																											
A	W TASKS_START			Start temperature measurement																											
		Trigger	1	Trigger task																											

6.22.1.2 TASKS_STOP

Address offset: 0x004

Stop temperature measurement

Bit number	31 30 29 28 27 26 25 24 23 22 21 20 19 18 17 16 15 14 13 12 11 10 9 8 7 6 5 4 3 2 1 0																														
ID	A																														
Reset 0x00000000	0 0																														
ID	Acce Field	Value ID	Value	Description																											
A	W TASKS_STOP			Stop temperature measurement																											
		Trigger	1	Trigger task																											

6.22.1.3 EVENTS_DATARDY

Address offset: 0x100

Temperature measurement complete, data ready

Bit number	31 30 29 28 27 26 25 24 23 22 21 20 19 18 17 16 15 14 13 12 11 10 9 8 7 6 5 4 3 2 1 0																														
ID	A																														
Reset 0x00000000	0 0																														
ID	Acce Field	Value ID	Value	Description																											
A	RW EVENTS_DATARDY			Temperature measurement complete, data ready																											
		NotGenerated	0	Event not generated																											
		Generated	1	Event generated																											

6.22.1.4 INTENSET

Address offset: 0x304

Enable interrupt

Bit number	31 30 29 28 27 26 25 24 23 22 21 20 19 18 17 16 15 14 13 12 11 10 9 8 7 6 5 4 3 2 1 0																														
ID	A																														
Reset 0x00000000	0 0																														
ID	Acce Field	Value ID	Value	Description																											
A	RW DATARDY			Write '1' to enable interrupt for event DATARDY																											
		Set	1	Enable																											
		Disabled	0	Read: Disabled																											
		Enabled	1	Read: Enabled																											

6.22.1.5 INTENCLR

Address offset: 0x308

Disable interrupt

Bit number	31 30 29 28 27 26 25 24 23 22 21 20 19 18 17 16 15 14 13 12 11 10 9 8 7 6 5 4 3 2 1 0																														
ID	A																														
Reset 0x00000000	0 0																														
ID	Acce Field	Value ID	Value	Description																											
A	RW DATARDY			Write '1' to disable interrupt for event DATARDY																											
		Clear	1	Disable																											
		Disabled	0	Read: Disabled																											
		Enabled	1	Read: Enabled																											

6.22.1.6 TEMP

Address offset: 0x508

Temperature in °C (0.25° steps)

Bit number	31 30 29 28 27 26 25 24 23 22 21 20 19 18 17 16 15 14 13 12 11 10 9 8 7 6 5 4 3 2 1 0																														
ID	A A																														
Reset 0x00000000	0 0																														
ID	Acce Field	Value ID	Value	Description																											
A	R TEMP			Temperature in °C (0.25° steps)																											
				Result of temperature measurement. Die temperature in °C, 2's complement format, 0.25 °C steps																											
				Decision point: DATARDY																											

6.22.1.7 A0

Address offset: 0x520

Slope of 1st piece wise linear function

Bit number	31	30	29	28	27	26	25	24	23	22	21	20	19	18	17	16	15	14	13	12	11	10	9	8	7	6	5	4	3	2	1	0																							
ID																							A	A	A	A	A	A	A	A	A	A	A	A	A	A	A	A	A	A	A	A	A	A	A	A	A	A	A	A	A	A	A		
Reset 0x00000326																							0	0	0	0	0	0	0	0	0	0	0	0	0	0	0	0	0	0	0	0	0	0	0	1	1	0	0	1	0	0	1	1	0
ID	Acce Field	Value ID	Value	Description																																																			
A	RW	A0		Slope of 1st piece wise linear function																																																			

6.22.1.8 A1

Address offset: 0x524

Slope of 2nd piece wise linear function

Bit number	31	30	29	28	27	26	25	24	23	22	21	20	19	18	17	16	15	14	13	12	11	10	9	8	7	6	5	4	3	2	1	0																							
ID																							A	A	A	A	A	A	A	A	A	A	A	A	A	A	A	A	A	A	A	A	A	A	A	A	A	A	A	A	A	A	A		
Reset 0x00000348																							0	0	0	0	0	0	0	0	0	0	0	0	0	0	0	0	0	0	0	0	0	0	0	1	1	0	1	0	0	1	0	0	0
ID	Acce Field	Value ID	Value	Description																																																			
A	RW	A1		Slope of 2nd piece wise linear function																																																			

6.22.1.9 A2

Address offset: 0x528

Slope of 3rd piece wise linear function

Bit number	31	30	29	28	27	26	25	24	23	22	21	20	19	18	17	16	15	14	13	12	11	10	9	8	7	6	5	4	3	2	1	0																							
ID																							A	A	A	A	A	A	A	A	A	A	A	A	A	A	A	A	A	A	A	A	A	A	A	A	A	A	A	A	A	A	A		
Reset 0x000003AA																							0	0	0	0	0	0	0	0	0	0	0	0	0	0	0	0	0	0	0	0	0	0	0	1	1	1	0	1	0	1	0	1	0
ID	Acce Field	Value ID	Value	Description																																																			
A	RW	A2		Slope of 3rd piece wise linear function																																																			

6.22.1.10 A3

Address offset: 0x52C

Slope of 4th piece wise linear function

Bit number	31	30	29	28	27	26	25	24	23	22	21	20	19	18	17	16	15	14	13	12	11	10	9	8	7	6	5	4	3	2	1	0																								
ID																							A	A	A	A	A	A	A	A	A	A	A	A	A	A	A	A	A	A	A	A	A	A	A	A	A	A	A	A	A	A	A			
Reset 0x0000040E																							0	0	0	0	0	0	0	0	0	0	0	0	0	0	0	0	0	0	0	0	0	0	0	1	0	0	0	0	0	0	1	1	1	0
ID	Acce Field	Value ID	Value	Description																																																				
A	RW	A3		Slope of 4th piece wise linear function																																																				

6.22.1.11 A4

Address offset: 0x530

Slope of 5th piece wise linear function

Bit number	31	30	29	28	27	26	25	24	23	22	21	20	19	18	17	16	15	14	13	12	11	10	9	8	7	6	5	4	3	2	1	0																								
ID																								A	A	A	A	A	A	A	A	A	A	A	A	A	A	A	A	A	A	A	A	A	A	A	A	A	A	A	A	A	A	A		
Reset 0x00004BD																								0	0	0	0	0	0	0	0	0	0	0	0	0	0	0	0	0	0	0	0	0	0	1	0	0	1	0	1	1	1	1	0	1
ID	Acce Field	Value ID	Value	Description																																																				
A	RW	A4		Slope of 5th piece wise linear function																																																				

6.22.1.12 A5

Address offset: 0x534

Slope of 6th piece wise linear function

Bit number	31	30	29	28	27	26	25	24	23	22	21	20	19	18	17	16	15	14	13	12	11	10	9	8	7	6	5	4	3	2	1	0																								
ID																								A	A	A	A	A	A	A	A	A	A	A	A	A	A	A	A	A	A	A	A	A	A	A	A	A	A	A	A	A	A			
Reset 0x00005A3																								0	0	0	0	0	0	0	0	0	0	0	0	0	0	0	0	0	0	0	0	0	0	1	0	1	1	0	1	0	0	0	1	1
ID	Acce Field	Value ID	Value	Description																																																				
A	RW	A5		Slope of 6th piece wise linear function																																																				

6.22.1.13 B0

Address offset: 0x540

y-intercept of 1st piece wise linear function

Bit number	31	30	29	28	27	26	25	24	23	22	21	20	19	18	17	16	15	14	13	12	11	10	9	8	7	6	5	4	3	2	1	0																								
ID																								A	A	A	A	A	A	A	A	A	A	A	A	A	A	A	A	A	A	A	A	A	A	A	A	A	A	A	A	A	A			
Reset 0x00003FEF																								0	0	0	0	0	0	0	0	0	0	0	0	0	0	0	0	0	0	0	0	0	0	1	1	1	1	1	1	1	1	1	1	1
ID	Acce Field	Value ID	Value	Description																																																				
A	RW	B0		y-intercept of 1st piece wise linear function																																																				

6.22.1.14 B1

Address offset: 0x544

y-intercept of 2nd piece wise linear function

Bit number	31	30	29	28	27	26	25	24	23	22	21	20	19	18	17	16	15	14	13	12	11	10	9	8	7	6	5	4	3	2	1	0																									
ID																								A	A	A	A	A	A	A	A	A	A	A	A	A	A	A	A	A	A	A	A	A	A	A	A	A	A	A	A	A	A				
Reset 0x00003FBE																								0	0	0	0	0	0	0	0	0	0	0	0	0	0	0	0	0	0	0	0	0	0	1	1	1	1	1	1	0	1	1	1	1	0
ID	Acce Field	Value ID	Value	Description																																																					
A	RW	B1		y-intercept of 2nd piece wise linear function																																																					

6.22.1.15 B2

Address offset: 0x548

y-intercept of 3rd piece wise linear function

Bit number	31	30	29	28	27	26	25	24	23	22	21	20	19	18	17	16	15	14	13	12	11	10	9	8	7	6	5	4	3	2	1	0																									
ID																								A	A	A	A	A	A	A	A	A	A	A	A	A	A	A	A	A	A	A	A	A	A	A	A	A	A	A	A	A	A				
Reset 0x00003FBE																								0	0	0	0	0	0	0	0	0	0	0	0	0	0	0	0	0	0	0	0	0	0	1	1	1	1	1	1	0	1	1	1	1	0
ID	Acce Field	Value ID	Value	Description																																																					
A	RW	B2		y-intercept of 3rd piece wise linear function																																																					

6.22.1.16 B3

Address offset: 0x54C

y-intercept of 4th piece wise linear function

Bit number	31	30	29	28	27	26	25	24	23	22	21	20	19	18	17	16	15	14	13	12	11	10	9	8	7	6	5	4	3	2	1	0
ID	A A A A A A A A A A A A A A A A A A																															
Reset 0x00000012	0 0																															
ID	Acce Field	Value ID	Value	Description																												
A	RW	B3		y-intercept of 4th piece wise linear function																												

6.22.1.17 B4

Address offset: 0x550

y-intercept of 5th piece wise linear function

Bit number	31	30	29	28	27	26	25	24	23	22	21	20	19	18	17	16	15	14	13	12	11	10	9	8	7	6	5	4	3	2	1	0
ID	A A A A A A A A A A A A A A A A A A																															
Reset 0x00000124	0 1 0 0 1 0 0 1 0 0																															
ID	Acce Field	Value ID	Value	Description																												
A	RW	B4		y-intercept of 5th piece wise linear function																												

6.22.1.18 B5

Address offset: 0x554

y-intercept of 6th piece wise linear function

Bit number	31	30	29	28	27	26	25	24	23	22	21	20	19	18	17	16	15	14	13	12	11	10	9	8	7	6	5	4	3	2	1	0
ID	A A A A A A A A A A A A A A A A A A																															
Reset 0x0000027C	0 1 0 0 1 1 1 1 1 0 0																															
ID	Acce Field	Value ID	Value	Description																												
A	RW	B5		y-intercept of 6th piece wise linear function																												

6.22.1.19 T0

Address offset: 0x560

End point of 1st piece wise linear function

Bit number	31	30	29	28	27	26	25	24	23	22	21	20	19	18	17	16	15	14	13	12	11	10	9	8	7	6	5	4	3	2	1	0
ID	A A A A A A A A A A A A A A A A A A																															
Reset 0x000000E2	0 1 1 1 0 0 0 1 0																															
ID	Acce Field	Value ID	Value	Description																												
A	RW	T0		End point of 1st piece wise linear function																												

6.22.1.20 T1

Address offset: 0x564

End point of 2nd piece wise linear function

Bit number	31	30	29	28	27	26	25	24	23	22	21	20	19	18	17	16	15	14	13	12	11	10	9	8	7	6	5	4	3	2	1	0																								
ID																											A	A	A	A	A	A	A	A																						
Reset 0x00000000	0																										0	0	0	0	0	0	0	0	0	0	0	0	0	0	0	0	0	0	0	0	0	0	0	0	0	0	0	0	0	0
ID	Acce Field	Value ID	Value	Description																																																				
A	RW	T1		End point of 2nd piece wise linear function																																																				

6.22.1.21 T2

Address offset: 0x568

End point of 3rd piece wise linear function

Bit number	31	30	29	28	27	26	25	24	23	22	21	20	19	18	17	16	15	14	13	12	11	10	9	8	7	6	5	4	3	2	1	0																									
ID																											A	A	A	A	A	A	A	A	A	A																					
Reset 0x00000019	0																										0	0	0	0	0	0	0	0	0	0	0	0	0	0	0	0	0	0	0	0	0	0	0	0	0	0	1	1	0	0	1
ID	Acce Field	Value ID	Value	Description																																																					
A	RW	T2		End point of 3rd piece wise linear function																																																					

6.22.1.22 T3

Address offset: 0x56C

End point of 4th piece wise linear function

Bit number	31	30	29	28	27	26	25	24	23	22	21	20	19	18	17	16	15	14	13	12	11	10	9	8	7	6	5	4	3	2	1	0																										
ID																											A	A	A	A	A	A	A	A	A	A																						
Reset 0x0000003C	0																										0	0	0	0	0	0	0	0	0	0	0	0	0	0	0	0	0	0	0	0	0	0	0	0	0	0	1	1	1	1	0	0
ID	Acce Field	Value ID	Value	Description																																																						
A	RW	T3		End point of 4th piece wise linear function																																																						

6.22.1.23 T4

Address offset: 0x570

End point of 5th piece wise linear function

Bit number	31	30	29	28	27	26	25	24	23	22	21	20	19	18	17	16	15	14	13	12	11	10	9	8	7	6	5	4	3	2	1	0																											
ID																											A	A	A	A	A	A	A	A	A	A																							
Reset 0x00000050	0																										0	0	0	0	0	0	0	0	0	0	0	0	0	0	0	0	0	0	0	0	0	0	0	0	0	0	1	0	1	0	0	0	0
ID	Acce Field	Value ID	Value	Description																																																							
A	RW	T4		End point of 5th piece wise linear function																																																							

6.22.2 Electrical specification

6.22.2.1 Temperature Sensor Electrical Specification

Symbol	Description	Min.	Typ.	Max.	Units
t _{TEMP}	Time required for temperature measurement		36		μs
T _{TEMP,RANGE}	Temperature sensor range	-40		85	°C
T _{TEMP,ACC}	Temperature sensor accuracy	-5		5	°C
T _{TEMP,RES}	Temperature sensor resolution		0.25		°C
T _{TEMP,STB}	Sample to sample stability at constant device temperature		+/-0.25		°C
T _{TEMP,OFFST}	Sample offset at 25°C	-2.5		2.5	°C

6.23 TWI — I²C compatible two-wire interface

The TWI master is compatible with I²C operating at 100 kHz and 400 kHz.

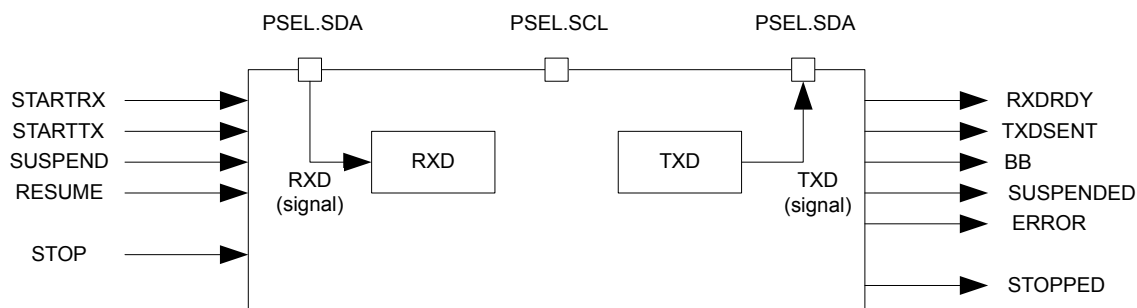

Figure 108: TWI master's main features

6.23.1 Functional description

This TWI master is not compatible with CBUS. The TWI transmitter and receiver are single buffered.

See, [TWI master's main features](#) on page 298.

A TWI setup comprising one master and three slaves is illustrated in [A typical TWI setup comprising one master and three slaves](#) on page 298. This TWI master is only able to operate as the only master on the TWI bus.

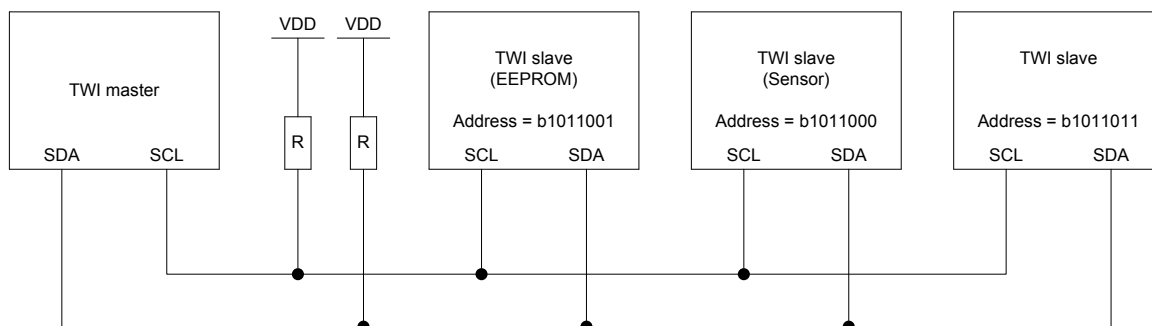

Figure 109: A typical TWI setup comprising one master and three slaves

This TWI master supports clock stretching performed by the slaves. The TWI master is started by triggering the STARTTX or STARTRX tasks, and stopped by triggering the STOP task.

If a NACK is clocked in from the slave, the TWI master will generate an ERROR event.

6.23.2 Master mode pin configuration

The different signals SCL and SDA associated with the TWI master are mapped to physical pins according to the configuration specified in the PSEL.SCL and PSEL.SDA registers respectively.

If the CONNECT field of a PSEL.xxx register is set to Disconnected, the associated TWI signal is not connected to any physical pin. The PSEL.SCL and PSEL.SDA registers and their configurations are only used

as long as the TWI master is enabled, and retained only as long as the device is in ON mode. PSEL.SCL and PSEL.SDA must only be configured when the TWI is disabled.

To secure correct signal levels on the pins used by the TWI master when the system is in OFF mode, and when the TWI master is disabled, these pins must be configured in the GPIO peripheral as described in [GPIO configuration](#) on page 299.

Only one peripheral can be assigned to drive a particular GPIO pin at a time, failing to do so may result in unpredictable behavior.

TWI master signal	TWI master pin	Direction	Drive strength	Output value
SCL	As specified in PSEL.SCL	Input	SOD1	Not applicable
SDA	As specified in PSEL.SDA	Input	SOD1	Not applicable

Table 91: GPIO configuration

6.23.3 Shared resources

The TWI shares registers and other resources with other peripherals that have the same ID as the TWI.

Therefore, you must disable all peripherals that have the same ID as the TWI before the TWI can be configured and used. Disabling a peripheral that has the same ID as the TWI will not reset any of the registers that are shared with the TWI. It is therefore important to configure all relevant TWI registers explicitly to secure that it operates correctly.

The Instantiation table in [Instantiation](#) on page 19 shows which peripherals have the same ID as the TWI.

6.23.4 Master write sequence

A TWI master write sequence is started by triggering the STARTTX task. After the STARTTX task has been triggered, the TWI master will generate a start condition on the TWI bus, followed by clocking out the address and the READ/WRITE bit set to 0 (WRITE=0, READ=1).

The address must match the address of the slave device that the master wants to write to. The READ/WRITE bit is followed by an ACK/NACK bit (ACK=0 or NACK=1) generated by the slave.

After receiving the ACK bit, the TWI master will clock out the data bytes that are written to the TXD register. Each byte clocked out from the master will be followed by an ACK/NACK bit clocked in from the slave. A TXDSENT event will be generated each time the TWI master has clocked out a TXD byte, and the associated ACK/NACK bit has been clocked in from the slave.

The TWI master transmitter is single buffered, and a second byte can only be written to the TXD register after the previous byte has been clocked out and the ACK/NACK bit clocked in, that is, after the TXDSENT event has been generated.

If the CPU is prevented from writing to TXD when the TWI master is ready to clock out a byte, the TWI master will stretch the clock until the CPU has written a byte to the TXD register.

A typical TWI master write sequence is illustrated in [The TWI master writing data to a slave](#) on page 300. Occurrence 3 in the figure illustrates delayed processing of the TXDSENT event associated with TXD byte 1. In this scenario the TWI master will stretch the clock to prevent writing erroneous data to the slave.

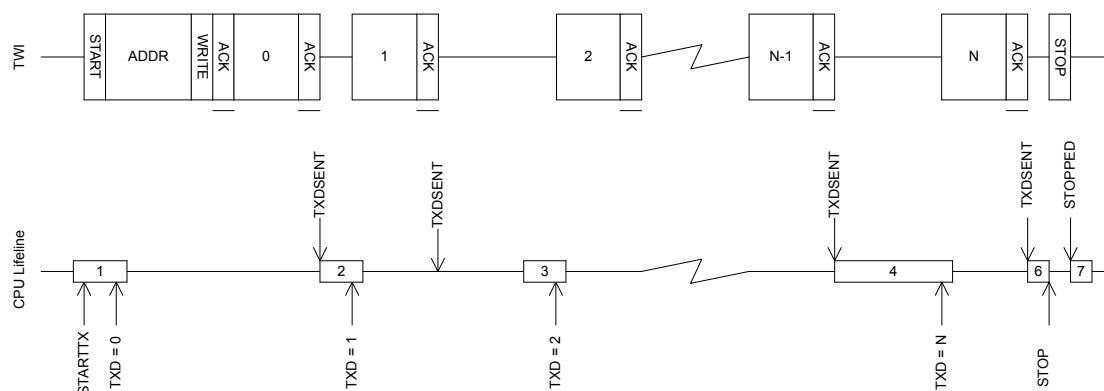

Figure 110: The TWI master writing data to a slave

The TWI master write sequence is stopped when the STOP task is triggered whereupon the TWI master will generate a stop condition on the TWI bus.

6.23.5 Master read sequence

A TWI master read sequence is started by triggering the STARTRX task. After the STARTRX task has been triggered the TWI master will generate a start condition on the TWI bus, followed by clocking out the address and the READ/WRITE bit set to 1 (WRITE = 0, READ = 1).

The address must match the address of the slave device that the master wants to read from. The READ/WRITE bit is followed by an ACK/NACK bit (ACK=0 or NACK = 1) generated by the slave.

After having sent the ACK bit the TWI slave will send data to the master using the clock generated by the master.

The TWI master will generate a RXDRDY event every time a new byte is received in the RXD register.

After receiving a byte, the TWI master will delay sending the ACK/NACK bit by stretching the clock until the CPU has extracted the received byte, that is, by reading the RXD register.

The TWI master read sequence is stopped by triggering the STOP task. This task must be triggered before the last byte is extracted from RXD to ensure that the TWI master sends a NACK back to the slave before generating the stop condition.

A typical TWI master read sequence is illustrated in [The TWI master reading data from a slave](#) on page 301. Occurrence 3 in this figure illustrates delayed processing of the RXDRDY event associated with RXD byte B. In this scenario the TWI master will stretch the clock to prevent the slave from overwriting the contents of the RXD register.

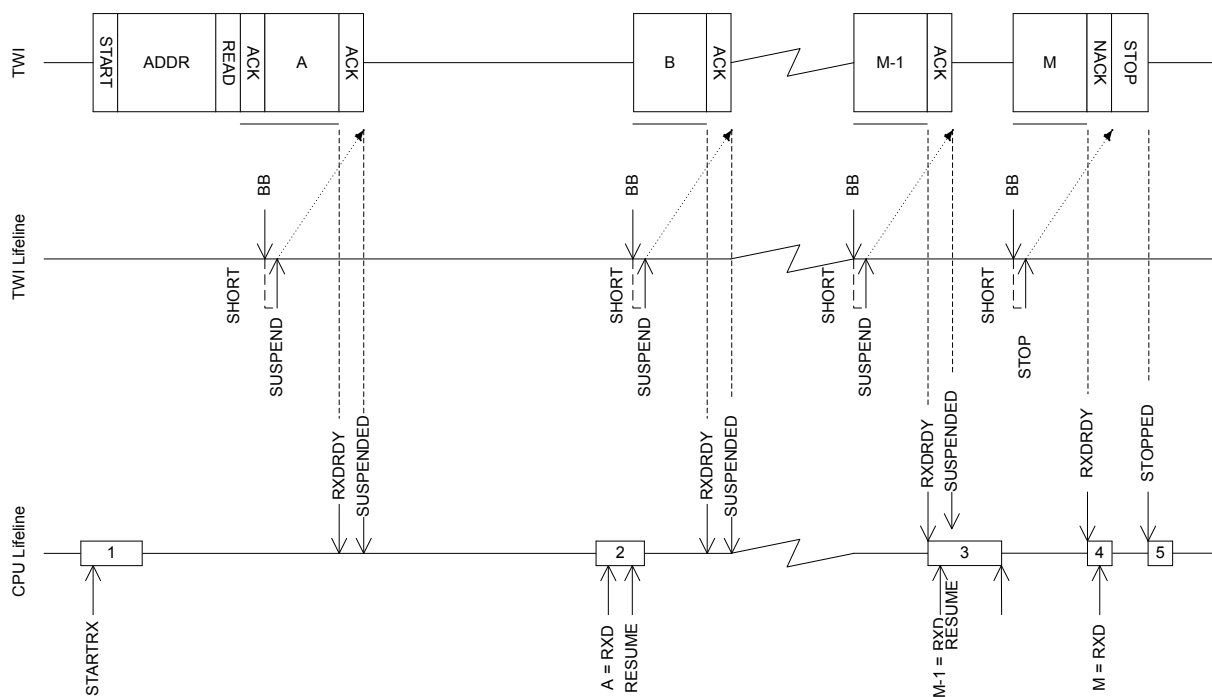

Figure 111: The TWI master reading data from a slave

6.23.6 Master repeated start sequence

A typical repeated start sequence is one in which the TWI master writes one byte to the slave followed by reading M bytes from the slave. Any combination and number of transmit and receive sequences can be combined in this fashion. Only one shortcut to STOP can be enabled at any given time.

The figure below illustrates a repeated start sequence where the TWI master writes one byte, followed by reading M bytes from the slave without performing a stop in-between.

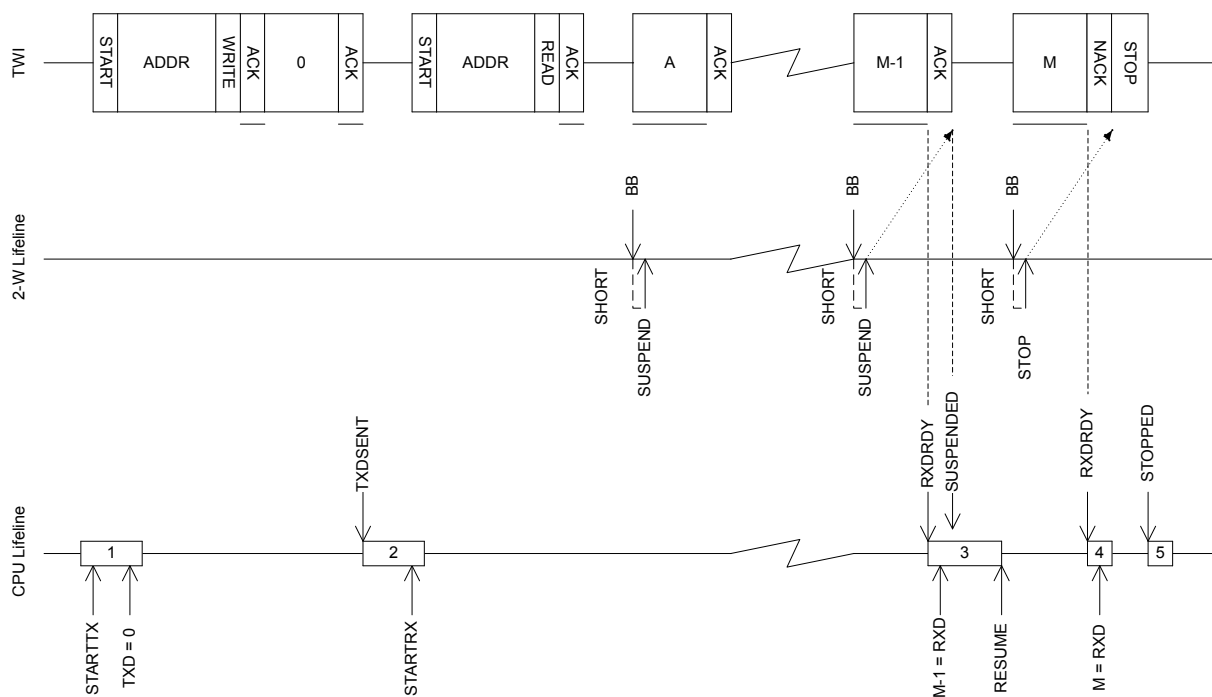

Figure 112: A repeated start sequence, where the TWI master writes one byte, followed by reading M bytes from the slave without performing a stop in-between

To generate a repeated start after a read sequence, a second start task must be triggered instead of the STOP task, that is, STARTRX or STARTTX. This start task must be triggered before the last byte is extracted from RXD to ensure that the TWI master sends a NACK back to the slave before generating the repeated start condition.

6.23.7 Low power

When putting the system in low power and the peripheral is not needed, lowest possible power consumption is achieved by stopping, and then disabling the peripheral.

The STOP task may not be always needed (the peripheral might already be stopped), but if it is sent, software shall wait until the STOPPED event was received as a response before disabling the peripheral through the ENABLE register.

6.23.8 Registers

Base address	Peripheral	Instance	Description	Configuration
0x40003000	TWI	TWI0	Two-wire interface master	Deprecated

Table 92: Instances

Register	Offset	Description
TASKS_STARTRX	0x000	Start TWI receive sequence
TASKS_STARTTX	0x008	Start TWI transmit sequence
TASKS_STOP	0x014	Stop TWI transaction
TASKS_SUSPEND	0x01C	Suspend TWI transaction
TASKS_RESUME	0x020	Resume TWI transaction
EVENTS_STOPPED	0x104	TWI stopped
EVENTS_RXDREADY	0x108	TWI RXD byte received
EVENTS_TXDSENT	0x11C	TWI TXD byte sent
EVENTS_ERROR	0x124	TWI error
EVENTS_BB	0x138	TWI byte boundary, generated before each byte that is sent or received
EVENTS_SUSPENDED	0x148	TWI entered the suspended state
SHORTS	0x200	Shortcuts between local events and tasks
INTENSET	0x304	Enable interrupt
INTENCLR	0x308	Disable interrupt
ERRORSRC	0x4C4	Error source
ENABLE	0x500	Enable TWI
PSEL_SCL	0x508	Pin select for SCL
PSEL_SDA	0x50C	Pin select for SDA
RXD	0x518	RXD register
TXD	0x51C	TXD register
FREQUENCY	0x524	TWI frequency. Accuracy depends on the HFCLK source selected.
ADDRESS	0x588	Address used in the TWI transfer

Table 93: Register overview

6.23.8.1 TASKS_STARTRX

Address offset: 0x000

Start TWI receive sequence

Bit number	31	30	29	28	27	26	25	24	23	22	21	20	19	18	17	16	15	14	13	12	11	10	9	8	7	6	5	4	3	2	1	0
ID																																A
Reset 0x00000000	0 0																															
ID	Acce Field	Value ID	Value	Description																												
A	W TASKS_STARTRX			Start TWI receive sequence																												
		Trigger	1	Trigger task																												

6.23.8.2 TASKS_STARTTX

Address offset: 0x008

Start TWI transmit sequence

Bit number	31	30	29	28	27	26	25	24	23	22	21	20	19	18	17	16	15	14	13	12	11	10	9	8	7	6	5	4	3	2	1	0
ID																																A
Reset 0x00000000	0 0																															
ID	Acce Field	Value ID	Value	Description																												
A	W TASKS_STARTTX			Start TWI transmit sequence																												
		Trigger	1	Trigger task																												

6.23.8.3 TASKS_STOP

Address offset: 0x014

Stop TWI transaction

Bit number	31	30	29	28	27	26	25	24	23	22	21	20	19	18	17	16	15	14	13	12	11	10	9	8	7	6	5	4	3	2	1	0
ID																																A
Reset 0x00000000	0 0																															
ID	Acce Field	Value ID	Value	Description																												
A	W TASKS_STOP			Stop TWI transaction																												
		Trigger	1	Trigger task																												

6.23.8.4 TASKS_SUSPEND

Address offset: 0x01C

Suspend TWI transaction

Bit number	31	30	29	28	27	26	25	24	23	22	21	20	19	18	17	16	15	14	13	12	11	10	9	8	7	6	5	4	3	2	1	0
ID																																A
Reset 0x00000000	0 0																															
ID	Acce Field	Value ID	Value	Description																												
A	W TASKS_SUSPEND			Suspend TWI transaction																												
		Trigger	1	Trigger task																												

6.23.8.5 TASKS_RESUME

Address offset: 0x020

Resume TWI transaction

Bit number	31	30	29	28	27	26	25	24	23	22	21	20	19	18	17	16	15	14	13	12	11	10	9	8	7	6	5	4	3	2	1	0
ID																																A
Reset 0x00000000	0 0																															
ID	Acce Field	Value ID	Value	Description																												
A	W TASKS_RESUME	Trigger	1	Resume TWI transaction Trigger task																												

6.23.8.6 EVENTS_STOPPED

Address offset: 0x104

TWI stopped

Bit number	31	30	29	28	27	26	25	24	23	22	21	20	19	18	17	16	15	14	13	12	11	10	9	8	7	6	5	4	3	2	1	0
ID																																A
Reset 0x00000000	0 0																															
ID	Acce Field	Value ID	Value	Description																												
A	RW EVENTS_STOPPED	NotGenerated	0	TWI stopped Event not generated																												
		Generated	1	Event generated																												

6.23.8.7 EVENTS_RXDREADY

Address offset: 0x108

TWI RXD byte received

Bit number	31	30	29	28	27	26	25	24	23	22	21	20	19	18	17	16	15	14	13	12	11	10	9	8	7	6	5	4	3	2	1	0
ID																																A
Reset 0x00000000	0 0																															
ID	Acce Field	Value ID	Value	Description																												
A	RW EVENTS_RXDREADY	NotGenerated	0	TWI RXD byte received Event not generated																												
		Generated	1	Event generated																												

6.23.8.8 EVENTS_TXDSENT

Address offset: 0x11C

TWI TXD byte sent

Bit number	31	30	29	28	27	26	25	24	23	22	21	20	19	18	17	16	15	14	13	12	11	10	9	8	7	6	5	4	3	2	1	0
ID																																A
Reset 0x00000000	0 0																															
ID	Acce Field	Value ID	Value	Description																												
A	RW EVENTS_TXDSENT	NotGenerated	0	TWI TXD byte sent Event not generated																												
		Generated	1	Event generated																												

6.23.8.9 EVENTS_ERROR

Address offset: 0x124

TWI error

Bit number	31 30 29 28 27 26 25 24 23 22 21 20 19 18 17 16 15 14 13 12 11 10 9 8 7 6 5 4 3 2 1 0																														
ID	A																														
Reset 0x00000000	0 0																														
ID	Acce Field	Value ID	Value	Description																											
A	RW EVENTS_ERROR			TWI error																											
		NotGenerated	0	Event not generated																											
		Generated	1	Event generated																											

6.23.8.10 EVENTS_BB

Address offset: 0x138

TWI byte boundary, generated before each byte that is sent or received

Bit number	31 30 29 28 27 26 25 24 23 22 21 20 19 18 17 16 15 14 13 12 11 10 9 8 7 6 5 4 3 2 1 0																														
ID	A																														
Reset 0x00000000	0 0																														
ID	Acce Field	Value ID	Value	Description																											
A	RW EVENTS_BB			TWI byte boundary, generated before each byte that is sent or received																											
		NotGenerated	0	Event not generated																											
		Generated	1	Event generated																											

6.23.8.11 EVENTS_SUSPENDED

Address offset: 0x148

TWI entered the suspended state

Generated just after ACK bit has been transferred in a read transaction, and only if SUSPEND has been requested earlier.

Bit number	31 30 29 28 27 26 25 24 23 22 21 20 19 18 17 16 15 14 13 12 11 10 9 8 7 6 5 4 3 2 1 0																														
ID	A																														
Reset 0x00000000	0 0																														
ID	Acce Field	Value ID	Value	Description																											
A	RW EVENTS_SUSPENDED			TWI entered the suspended state																											
				Generated just after ACK bit has been transferred in a read transaction, and only if SUSPEND has been requested earlier.																											
		NotGenerated	0	Event not generated																											
		Generated	1	Event generated																											

6.23.8.12 SHORTS

Address offset: 0x200

Shortcuts between local events and tasks

Bit number	31	30	29	28	27	26	25	24	23	22	21	20	19	18	17	16	15	14	13	12	11	10	9	8	7	6	5	4	3	2	1	0
ID																															B	A
Reset	0x00000000																															
0	0	0	0	0	0	0	0	0	0	0	0	0	0	0	0	0	0	0	0	0	0	0	0	0	0	0	0	0	0	0	0	0
ID	Acce	Field	Value	ID	Value	Description																										
A	RW	BB_SUSPEND				Shortcut between event BB and task SUSPEND																										
			Disabled	0		Disable shortcut																										
			Enabled	1		Enable shortcut																										
B	RW	BB_STOP				Shortcut between event BB and task STOP																										
			Disabled	0		Disable shortcut																										
			Enabled	1		Enable shortcut																										

6.23.8.13 INTENSET

Address offset: 0x304

Enable interrupt

Bit number	31	30	29	28	27	26	25	24	23	22	21	20	19	18	17	16	15	14	13	12	11	10	9	8	7	6	5	4	3	2	1	0
ID																F	E	D	C											B	A	
Reset	0x00000000																															
0	0	0	0	0	0	0	0	0	0	0	0	0	0	0	0	0	0	0	0	0	0	0	0	0	0	0	0	0	0	0	0	0
ID	Acce	Field	Value	ID	Value	Description																										
A	RW	STOPPED				Write '1' to enable interrupt for event STOPPED																										
			Set	1		Enable																										
			Disabled	0		Read: Disabled																										
			Enabled	1		Read: Enabled																										
B	RW	RXDREADY				Write '1' to enable interrupt for event RXDREADY																										
			Set	1		Enable																										
			Disabled	0		Read: Disabled																										
			Enabled	1		Read: Enabled																										
C	RW	TXDSENT				Write '1' to enable interrupt for event TXDSENT																										
			Set	1		Enable																										
			Disabled	0		Read: Disabled																										
			Enabled	1		Read: Enabled																										
D	RW	ERROR				Write '1' to enable interrupt for event ERROR																										
			Set	1		Enable																										
			Disabled	0		Read: Disabled																										
			Enabled	1		Read: Enabled																										
E	RW	BB				Write '1' to enable interrupt for event BB																										
			Set	1		Enable																										
			Disabled	0		Read: Disabled																										
			Enabled	1		Read: Enabled																										
F	RW	SUSPENDED				Write '1' to enable interrupt for event SUSPENDED																										
						Generated just after ACK bit has been transferred in a read transaction, and only if SUSPEND has been requested earlier.																										
			Set	1		Enable																										
			Disabled	0		Read: Disabled																										
			Enabled	1		Read: Enabled																										

6.23.8.14 INTENCLR

Address offset: 0x308

Disable interrupt

Bit number		31 30 29 28 27 26 25 24 23 22 21 20 19 18 17 16 15 14 13 12 11 10 9 8 7 6 5 4 3 2 1 0																																	
ID		F														E							D							C		B		A	
Reset 0x00000000		0 0																																	
ID	Acce Field	Value ID	Value	Description																															
A	RW STOPPED			Write '1' to disable interrupt for event STOPPED																															
		Clear	1	Disable																															
		Disabled	0	Read: Disabled																															
		Enabled	1	Read: Enabled																															
B	RW RXDREADY			Write '1' to disable interrupt for event RXDREADY																															
		Clear	1	Disable																															
		Disabled	0	Read: Disabled																															
		Enabled	1	Read: Enabled																															
C	RW TXDSENT			Write '1' to disable interrupt for event TXDSENT																															
		Clear	1	Disable																															
		Disabled	0	Read: Disabled																															
		Enabled	1	Read: Enabled																															
D	RW ERROR			Write '1' to disable interrupt for event ERROR																															
		Clear	1	Disable																															
		Disabled	0	Read: Disabled																															
		Enabled	1	Read: Enabled																															
E	RW BB			Write '1' to disable interrupt for event BB																															
		Clear	1	Disable																															
		Disabled	0	Read: Disabled																															
		Enabled	1	Read: Enabled																															
F	RW SUSPENDED			Write '1' to disable interrupt for event SUSPENDED																															
				Generated just after ACK bit has been transferred in a read transaction, and only if SUSPEND has been requested earlier.																															
		Clear	1	Disable																															
		Disabled	0	Read: Disabled																															
		Enabled	1	Read: Enabled																															

6.23.8.15 ERRORSRC

Address offset: 0x4C4

Error source

Bit number		31 30 29 28 27 26 25 24 23 22 21 20 19 18 17 16 15 14 13 12 11 10 9 8 7 6 5 4 3 2 1 0																															
ID																							C							B		A	
Reset 0x00000000		0 0																															
ID	Acce Field	Value ID	Value	Description																													
A	RW OVERRUN			Overrun error																													
				A new byte was received before previous byte got read by software from the RXD register. (Previous data is lost)																													
		NotPresent	0	Read: no overrun occurred																													
		Present	1	Read: overrun occurred																													
B	RW ANACK			NACK received after sending the address (write '1' to clear)																													
		NotPresent	0	Read: error not present																													
		Present	1	Read: error present																													
C	RW DNACK			NACK received after sending a data byte (write '1' to clear)																													
		NotPresent	0	Read: error not present																													
		Present	1	Read: error present																													

6.23.8.16 ENABLE

Address offset: 0x500

Enable TWI

Bit number	31 30 29 28 27 26 25 24 23 22 21 20 19 18 17 16 15 14 13 12 11 10 9 8 7 6 5 4 3 2 1 0																																	
ID																															A	A	A	A
Reset 0x00000000	0 0																																	
ID	Acce Field	Value ID	Value	Description																														
A	RW ENABLE			Enable or disable TWI																														
		Disabled	0	Disable TWI																														
		Enabled	5	Enable TWI																														

6.23.8.17 PSEL.SCL

Address offset: 0x508

Pin select for SCL

Bit number	31 30 29 28 27 26 25 24 23 22 21 20 19 18 17 16 15 14 13 12 11 10 9 8 7 6 5 4 3 2 1 0																																	
ID	C																														A	A	A	A
Reset 0xFFFFFFFF	1 1																																	
ID	Acce Field	Value ID	Value	Description																														
A	RW PIN		[0..31]	Pin number																														
C	RW CONNECT			Connection																														
		Disconnected	1	Disconnect																														
		Connected	0	Connect																														

6.23.8.18 PSEL.SDA

Address offset: 0x50C

Pin select for SDA

Bit number	31 30 29 28 27 26 25 24 23 22 21 20 19 18 17 16 15 14 13 12 11 10 9 8 7 6 5 4 3 2 1 0																																	
ID	C																														A	A	A	A
Reset 0xFFFFFFFF	1 1																																	
ID	Acce Field	Value ID	Value	Description																														
A	RW PIN		[0..31]	Pin number																														
C	RW CONNECT			Connection																														
		Disconnected	1	Disconnect																														
		Connected	0	Connect																														

6.23.8.19 RXD

Address offset: 0x518

RXD register

Bit number	31 30 29 28 27 26 25 24 23 22 21 20 19 18 17 16 15 14 13 12 11 10 9 8 7 6 5 4 3 2 1 0																																			
ID																															A	A	A	A	A	A
Reset 0x00000000	0 0																																			
ID	Acce Field	Value ID	Value	Description																																
A	R			RXD register																																

6.23.8.20 TXD

Address offset: 0x51C

TXD register

Bit number	31	30	29	28	27	26	25	24	23	22	21	20	19	18	17	16	15	14	13	12	11	10	9	8	7	6	5	4	3	2	1	0
ID	A A A A A A A A																															
Reset 0x00000000	0 0																															
ID	Acce Field	Value ID	Value	Description																												
A	RW	TXD		TXD register																												

6.23.8.21 FREQUENCY

Address offset: 0x524

TWI frequency. Accuracy depends on the HFCLK source selected.

Bit number	31	30	29	28	27	26	25	24	23	22	21	20	19	18	17	16	15	14	13	12	11	10	9	8	7	6	5	4	3	2	1	0
ID	A A																															
Reset 0x04000000	0 0 0 0 0 1 0																															
ID	Acce Field	Value ID	Value	Description																												
A	RW	FREQUENCY		TWI master clock frequency																												
		K100	0x01980000	100 kbps																												
		K250	0x04000000	250 kbps																												
		K400	0x06680000	400 kbps (actual rate 410.256 kbps)																												

6.23.8.22 ADDRESS

Address offset: 0x588

Address used in the TWI transfer

Bit number	31	30	29	28	27	26	25	24	23	22	21	20	19	18	17	16	15	14	13	12	11	10	9	8	7	6	5	4	3	2	1	0
ID	A A A A A A A A																															
Reset 0x00000000	0 0																															
ID	Acce Field	Value ID	Value	Description																												
A	RW	ADDRESS		Address used in the TWI transfer																												

6.23.9 Electrical specification

6.23.9.1 TWI interface electrical specifications

Symbol	Description	Min.	Typ.	Max.	Units
$f_{TWI,SCL}$	Bit rates for TWI ²⁹	100		400	kbps
$t_{TWI,START}$	Time from STARTRX/STARTTX task to transmission started		1.5		μ s

²⁹ High bit rates or stronger pull-ups may require GPIOs to be set as High Drive, see GPIO chapter for more details.

6.23.9.2 Two Wire Interface (TWI) timing specifications

Symbol	Description	Min.	Typ.	Max.	Units
t_{TWI,SU_DAT}	Data setup time before positive edge on SCL – all modes	300			ns
t_{TWI,HD_DAT}	Data hold time after negative edge on SCL – all modes	500			ns
$t_{TWI,HD_STA,100kbps}$	TWI master hold time for START and repeated START condition, 100 kbps	10000			ns
$t_{TWI,HD_STA,250kbps}$	TWI master hold time for START and repeated START condition, 250kbps	4000			ns
$t_{TWI,HD_STA,400kbps}$	TWI master hold time for START and repeated START condition, 400 kbps	2500			ns
$t_{TWI,SU_STO,100kbps}$	TWI master setup time from SCL high to STOP condition, 100 kbps	5000			ns
$t_{TWI,SU_STO,250kbps}$	TWI master setup time from SCL high to STOP condition, 250 kbps	2000			ns
$t_{TWI,SU_STO,400kbps}$	TWI master setup time from SCL high to STOP condition, 400 kbps	1250			ns
$t_{TWI,BUF,100kbps}$	TWI master bus free time between STOP and START conditions, 100 kbps	5800			ns
$t_{TWI,BUF,250kbps}$	TWI master bus free time between STOP and START conditions, 250 kbps	2700			ns
$t_{TWI,BUF,400kbps}$	TWI master bus free time between STOP and START conditions, 400 kbps	2100			ns

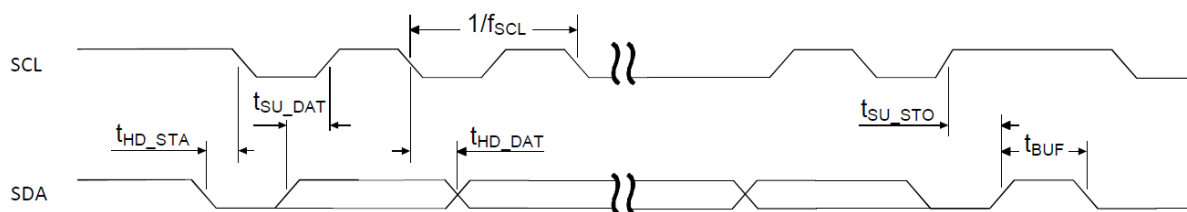

Figure 113: TWI timing diagram, 1 byte transaction

6.24 TIMER — Timer/counter

The TIMER can operate in two modes: timer and counter.

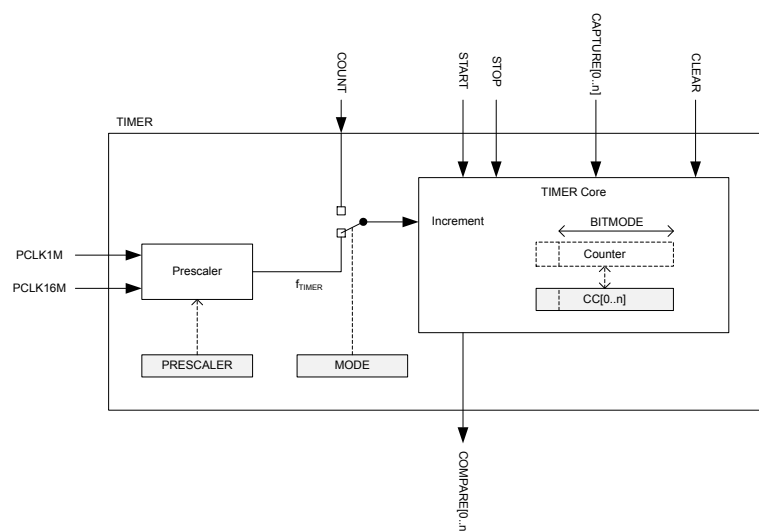

Figure 114: Block schematic for timer/counter

The timer/counter runs on the high-frequency clock source (HFCLK) and includes a four-bit (1/2X) prescaler that can divide the timer input clock from the HFCLK controller. Clock source selection between PCLK16M and PCLK1M is automatic according to TIMER base frequency set by the prescaler. The TIMER base frequency is always given as 16 MHz divided by the prescaler value.

The PPI system allows a TIMER event to trigger a task of any other system peripheral of the device. The PPI system also enables the TIMER task/event features to generate periodic output and PWM signals to any GPIO. The number of input/outputs used at the same time is limited by the number of GPIOTE channels.

The TIMER can operate in two modes, Timer mode and Counter mode. In both modes, the TIMER is started by triggering the START task, and stopped by triggering the STOP task. After the timer is stopped the timer can resume timing/counting by triggering the START task again. When timing/counting is resumed, the timer will continue from the value it had prior to being stopped.

In Timer mode, the TIMER's internal Counter register is incremented by one for every tick of the timer frequency f_{TIMER} as illustrated in [Block schematic for timer/counter](#) on page 311. The timer frequency is derived from PCLK16M as shown below, using the values specified in the PRESCALER register:

$$f_{\text{TIMER}} = 16 \text{ MHz} / (2^{\text{PRESCALER}})$$

When $f_{\text{TIMER}} \leq 1 \text{ MHz}$ the TIMER will use PCLK1M instead of PCLK16M for reduced power consumption.

In counter mode, the TIMER's internal Counter register is incremented by one each time the COUNT task is triggered, that is, the timer frequency and the prescaler are not utilized in counter mode. Similarly, the COUNT task has no effect in Timer mode.

The TIMER's maximum value is configured by changing the bit-width of the timer in the [BITMODE](#) on page 316 register.

[PRESCALER](#) on page 316 and the [BITMODE](#) on page 316 must only be updated when the timer is stopped. If these registers are updated while the TIMER is started then this may result in unpredictable behavior.

When the timer is incremented beyond its maximum value the Counter register will overflow and the TIMER will automatically start over from zero.

The Counter register can be cleared, that is, its internal value set to zero explicitly, by triggering the CLEAR task.

The TIMER implements multiple capture/compare registers.

Independent of prescaler setting the accuracy of the TIMER is equivalent to one tick of the timer frequency f_{TIMER} as illustrated in [Block schematic for timer/counter](#) on page 311.

6.24.1 Capture

The TIMER implements one capture task for every available capture/compare register.

Every time the CAPTURE[n] task is triggered, the Counter value is copied to the CC[n] register.

6.24.2 Compare

The TIMER implements one COMPARE event for every available capture/compare register.

A COMPARE event is generated when the Counter is incremented and then becomes equal to the value specified in one of the capture compare registers. When the Counter value becomes equal to the value specified in a capture compare register CC[n], the corresponding compare event COMPARE[n] is generated.

BITMODE on page 316 specifies how many bits of the Counter register and the capture/compare register that are used when the comparison is performed. Other bits will be ignored.

6.24.3 Task delays

After the TIMER is started, the CLEAR task, COUNT task and the STOP task will guarantee to take effect within one clock cycle of the PCLK16M.

6.24.4 Task priority

If the START task and the STOP task are triggered at the same time, that is, within the same period of PCLK16M, the STOP task will be prioritized.

6.24.5 Registers

Base address	Peripheral	Instance	Description	Configuration
0x40008000	TIMER	TIMER0	Timer 0	This timer instance has 4 CC registers (CC[0..3])
0x40009000	TIMER	TIMER1	Timer 1	This timer instance has 4 CC registers (CC[0..3])
0x4000A000	TIMER	TIMER2	Timer 2	This timer instance has 4 CC registers (CC[0..3])

Table 94: Instances

Register	Offset	Description	
TASKS_START	0x000	Start Timer	
TASKS_STOP	0x004	Stop Timer	
TASKS_COUNT	0x008	Increment Timer (Counter mode only)	
TASKS_CLEAR	0x00C	Clear time	
TASKS_SHUTDOWN	0x010	Shut down timer	Deprecated
TASKS_CAPTURE[0]	0x040	Capture Timer value to CC[0] register	
TASKS_CAPTURE[1]	0x044	Capture Timer value to CC[1] register	
TASKS_CAPTURE[2]	0x048	Capture Timer value to CC[2] register	

Register	Offset	Description
TASKS_CAPTURE[3]	0x04C	Capture Timer value to CC[3] register
TASKS_CAPTURE[4]	0x050	Capture Timer value to CC[4] register
TASKS_CAPTURE[5]	0x054	Capture Timer value to CC[5] register
EVENTS_COMPARE[0]	0x140	Compare event on CC[0] match
EVENTS_COMPARE[1]	0x144	Compare event on CC[1] match
EVENTS_COMPARE[2]	0x148	Compare event on CC[2] match
EVENTS_COMPARE[3]	0x14C	Compare event on CC[3] match
EVENTS_COMPARE[4]	0x150	Compare event on CC[4] match
EVENTS_COMPARE[5]	0x154	Compare event on CC[5] match
SHORTS	0x200	Shortcuts between local events and tasks
INTENSET	0x304	Enable interrupt
INTENCLR	0x308	Disable interrupt
MODE	0x504	Timer mode selection
BITMODE	0x508	Configure the number of bits used by the TIMER
PRESCALER	0x510	Timer prescaler register
CC[0]	0x540	Capture/Compare register 0
CC[1]	0x544	Capture/Compare register 1
CC[2]	0x548	Capture/Compare register 2
CC[3]	0x54C	Capture/Compare register 3
CC[4]	0x550	Capture/Compare register 4
CC[5]	0x554	Capture/Compare register 5

Table 95: Register overview

6.24.5.1 TASKS_START

Address offset: 0x000

Start Timer

Bit number	31 30 29 28 27 26 25 24 23 22 21 20 19 18 17 16 15 14 13 12 11 10 9 8 7 6 5 4 3 2 1 0																														
ID	A																														
Reset 0x00000000	0 0																														
ID	Acce Field	Value ID	Value	Description																											
A	W TASKS_START			Start Timer																											
		Trigger	1	Trigger task																											

6.24.5.2 TASKS_STOP

Address offset: 0x004

Stop Timer

Bit number	31 30 29 28 27 26 25 24 23 22 21 20 19 18 17 16 15 14 13 12 11 10 9 8 7 6 5 4 3 2 1 0																														
ID	A																														
Reset 0x00000000	0 0																														
ID	Acce Field	Value ID	Value	Description																											
A	W TASKS_STOP			Stop Timer																											
		Trigger	1	Trigger task																											

6.24.5.3 TASKS_COUNT

Address offset: 0x008

Increment Timer (Counter mode only)

Bit number	31	30	29	28	27	26	25	24	23	22	21	20	19	18	17	16	15	14	13	12	11	10	9	8	7	6	5	4	3	2	1	0
ID																																A
Reset 0x00000000	0 0																															
ID	Acce Field	Value ID	Value	Description																												
A	W TASKS_COUNT			Increment Timer (Counter mode only)																												
		Trigger	1	Trigger task																												

6.24.5.4 TASKS_CLEAR

Address offset: 0x00C

Clear time

Bit number	31	30	29	28	27	26	25	24	23	22	21	20	19	18	17	16	15	14	13	12	11	10	9	8	7	6	5	4	3	2	1	0
ID																																A
Reset 0x00000000	0 0																															
ID	Acce Field	Value ID	Value	Description																												
A	W TASKS_CLEAR			Clear time																												
		Trigger	1	Trigger task																												

6.24.5.5 TASKS_SHUTDOWN (Deprecated)

Address offset: 0x010

Shut down timer

Bit number	31	30	29	28	27	26	25	24	23	22	21	20	19	18	17	16	15	14	13	12	11	10	9	8	7	6	5	4	3	2	1	0
ID																																A
Reset 0x00000000	0 0																															
ID	Acce Field	Value ID	Value	Description																												
A	W TASKS_SHUTDOWN			Shut down timer Deprecated																												
		Trigger	1	Trigger task																												

6.24.5.6 TASKS_CAPTURE[n] (n=0..5)

Address offset: 0x040 + (n × 0x4)

Capture Timer value to CC[n] register

Bit number	31	30	29	28	27	26	25	24	23	22	21	20	19	18	17	16	15	14	13	12	11	10	9	8	7	6	5	4	3	2	1	0
ID																																A
Reset 0x00000000	0 0																															
ID	Acce Field	Value ID	Value	Description																												
A	W TASKS_CAPTURE			Capture Timer value to CC[n] register																												
		Trigger	1	Trigger task																												

6.24.5.7 EVENTS_COMPARE[n] (n=0..5)

Address offset: 0x140 + (n × 0x4)

Compare event on CC[n] match

Bit number	31	30	29	28	27	26	25	24	23	22	21	20	19	18	17	16	15	14	13	12	11	10	9	8	7	6	5	4	3	2	1	0
ID																																A
Reset	0x00000000																															
Reset	0 0																															
ID	Acce Field	Value ID	Value	Description																												
A	RW EVENTS_COMPARE			Compare event on CC[n] match																												
		NotGenerated	0	Event not generated																												
		Generated	1	Event generated																												

6.24.5.8 SHORTS

Address offset: 0x200

Shortcuts between local events and tasks

Bit number	31	30	29	28	27	26	25	24	23	22	21	20	19	18	17	16	15	14	13	12	11	10	9	8	7	6	5	4	3	2	1	0							
ID																		L	K	J	I	H	G											F	E	D	C	B	A
Reset	0x00000000																																						
Reset	0 0																																						
ID	Acce Field	Value ID	Value	Description																																			
A-F	RW COMPARE[i]_CLEAR (i=0..5)			Shortcut between event COMPARE[i] and task CLEAR																																			
		Disabled	0	Disable shortcut																																			
		Enabled	1	Enable shortcut																																			
G-L	RW COMPARE[i]_STOP (i=0..5)			Shortcut between event COMPARE[i] and task STOP																																			
		Disabled	0	Disable shortcut																																			
		Enabled	1	Enable shortcut																																			

6.24.5.9 INTENSET

Address offset: 0x304

Enable interrupt

Bit number	31	30	29	28	27	26	25	24	23	22	21	20	19	18	17	16	15	14	13	12	11	10	9	8	7	6	5	4	3	2	1	0	
ID																		F	E	D	C	B	A										
Reset	0x00000000																																
Reset	0 0																																
ID	Acce Field	Value ID	Value	Description																													
A-F	RW COMPARE[i] (i=0..5)			Write '1' to enable interrupt for event COMPARE[i]																													
		Set	1	Enable																													
		Disabled	0	Read: Disabled																													
		Enabled	1	Read: Enabled																													

6.24.5.10 INTENCLR

Address offset: 0x308

Disable interrupt

Bit number	31 30 29 28 27 26 25 24 23 22 21 20 19 18 17 16 15 14 13 12 11 10 9 8 7 6 5 4 3 2 1 0																														
ID	F E D C B A																														
Reset	0x00000000																														
0	0 0																														
ID	Acce Field	Value ID	Value	Description																											
A-F	RW	COMPARE[i] (i=0..5)		Write '1' to disable interrupt for event COMPARE[i]																											
		Clear	1	Disable																											
		Disabled	0	Read: Disabled																											
		Enabled	1	Read: Enabled																											

6.24.5.11 MODE

Address offset: 0x504

Timer mode selection

Bit number	31 30 29 28 27 26 25 24 23 22 21 20 19 18 17 16 15 14 13 12 11 10 9 8 7 6 5 4 3 2 1 0																														
ID	A A																														
Reset	0x00000000																														
0	0 0																														
ID	Acce Field	Value ID	Value	Description																											
A	RW	MODE		Timer mode																											
		Timer	0	Select Timer mode																											
		Counter	1	Select Counter mode																											
		LowPowerCounter	2	Select Low Power Counter mode																											

Deprecated

6.24.5.12 BITMODE

Address offset: 0x508

Configure the number of bits used by the TIMER

Bit number	31 30 29 28 27 26 25 24 23 22 21 20 19 18 17 16 15 14 13 12 11 10 9 8 7 6 5 4 3 2 1 0																														
ID	A A																														
Reset	0x00000000																														
0	0 0																														
ID	Acce Field	Value ID	Value	Description																											
A	RW	BITMODE		Timer bit width																											
		16Bit	0	16 bit timer bit width																											
		08Bit	1	8 bit timer bit width																											
		24Bit	2	24 bit timer bit width																											
		32Bit	3	32 bit timer bit width																											

6.24.5.13 PRESCALER

Address offset: 0x510

Timer prescaler register

Bit number	31 30 29 28 27 26 25 24 23 22 21 20 19 18 17 16 15 14 13 12 11 10 9 8 7 6 5 4 3 2 1 0																														
ID	A A A A																														
Reset	0x00000004																														
0	0 1 0 0																														
ID	Acce Field	Value ID	Value	Description																											
A	RW	PRESCALER	[0..9]	Prescaler value																											

6.24.5.14 CC[n] (n=0..5)

Address offset: 0x540 + (n × 0x4)

Capture/Compare register n

Bit number	31	30	29	28	27	26	25	24	23	22	21	20	19	18	17	16	15	14	13	12	11	10	9	8	7	6	5	4	3	2	1	0	
ID	A	A	A	A	A	A	A	A	A	A	A	A	A	A	A	A	A	A	A	A	A	A	A	A	A	A	A	A	A	A	A	A	A
Reset 0x00000000	0	0	0	0	0	0	0	0	0	0	0	0	0	0	0	0	0	0	0	0	0	0	0	0	0	0	0	0	0	0	0	0	

ID	Acce Field	Value ID	Value	Description
A	RW	CC		Capture/Compare value

Only the number of bits indicated by BITMODE will be used by the TIMER.

6.25 TWIM — I²C compatible two-wire interface master with EasyDMA

TWI master with EasyDMA (TWIM) is a two-wire half-duplex master which can communicate with multiple slave devices connected to the same bus

Listed here are the main features for TWIM:

- I²C compatible
- Supported baud rates: 100, 250, 400 kbps
- Support for clock stretching (non I²C compliant)
- EasyDMA

The two-wire interface can communicate with a bi-directional wired-AND bus with two lines (SCL, SDA). The protocol makes it possible to interconnect up to 127 individually addressable devices. TWIM is not compatible with CBUS.

The GPIOs used for each two-wire interface line can be chosen from any GPIO on the device and are independently configurable. This enables great flexibility in device pinout and efficient use of board space and signal routing.

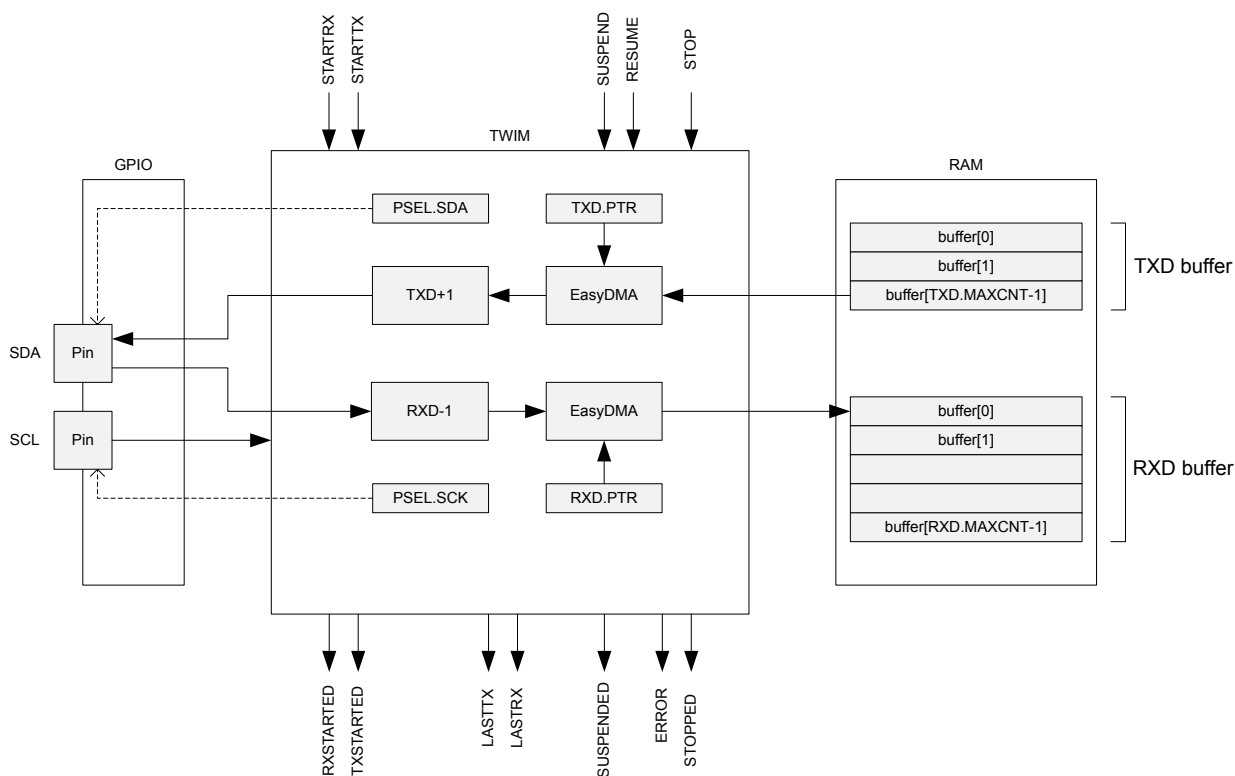

Figure 115: TWI master with EasyDMA

A typical TWI setup consists of one master and one or more slaves. For an example, see [A typical TWI setup comprising one master and three slaves](#) on page 318. This TWIM is only able to operate as a single master on the TWI bus. Multi-master bus configuration is not supported.

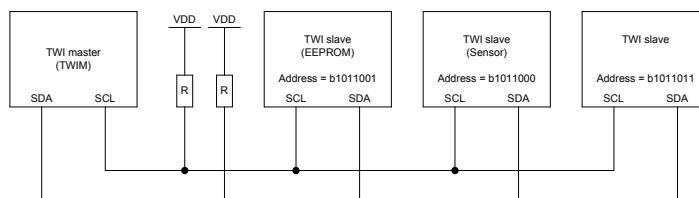

Figure 116: A typical TWI setup comprising one master and three slaves

This TWI master supports clock stretching performed by the slaves. Note that the SCK pulse following a stretched clock cycle may be shorter than specified by the I2C specification.

The TWI master is started by triggering the STARTTX or STARTRX tasks, and stopped by triggering the STOP task. The TWI master will generate a STOPPED event when it has stopped following a STOP task. The TWI master cannot get stopped while it is suspended, so the STOP task has to be issued after the TWI master has been resumed.

After the TWI master is started, the STARTTX task or the STARTRX task should not be triggered again before the TWI master has stopped, i.e. following a LASTRX, LASTTX or STOPPED event.

If a NACK is clocked in from the slave, the TWI master will generate an ERROR event.

6.25.1 EasyDMA

The TWIM implements EasyDMA for accessing RAM without CPU involvement.

The TWIM peripheral implements the following EasyDMA channels:

Channel	Type	Register Cluster
TXD	READER	TXD
RXD	WRITER	RXD

Table 96: TWIM EasyDMA Channels

For detailed information regarding the use of EasyDMA, see [EasyDMA](#) on page 36.

The .PTR and .MAXCNT registers are double-buffered. They can be updated and prepared for the next RX/TX transmission immediately after having received the RXSTARTED/TXSTARTED event.

The STOPPED event indicates that EasyDMA has finished accessing the buffer in RAM.

6.25.2 Master write sequence

A TWI master write sequence is started by triggering the STARTTX task. After the STARTTX task has been triggered, the TWI master will generate a start condition on the TWI bus, followed by clocking out the address and the READ/WRITE bit set to 0 (WRITE=0, READ=1).

The address must match the address of the slave device that the master wants to write to. The READ/WRITE bit is followed by an ACK/NACK bit (ACK=0 or NACK=1) generated by the slave.

After receiving the ACK bit, the TWI master will clock out the data bytes found in the transmit buffer located in RAM at the address specified in the TXD.PTR register. Each byte clocked out from the master will be followed by an ACK/NACK bit clocked in from the slave.

A typical TWI master write sequence is illustrated in [TWI master writing data to a slave](#) on page 319. Occurrence 2 in the figure illustrates clock stretching performed by the TWI master following a SUSPEND task.

A SUSPENDED event indicates that the SUSPEND task has taken effect; this event can be used to synchronize the software.

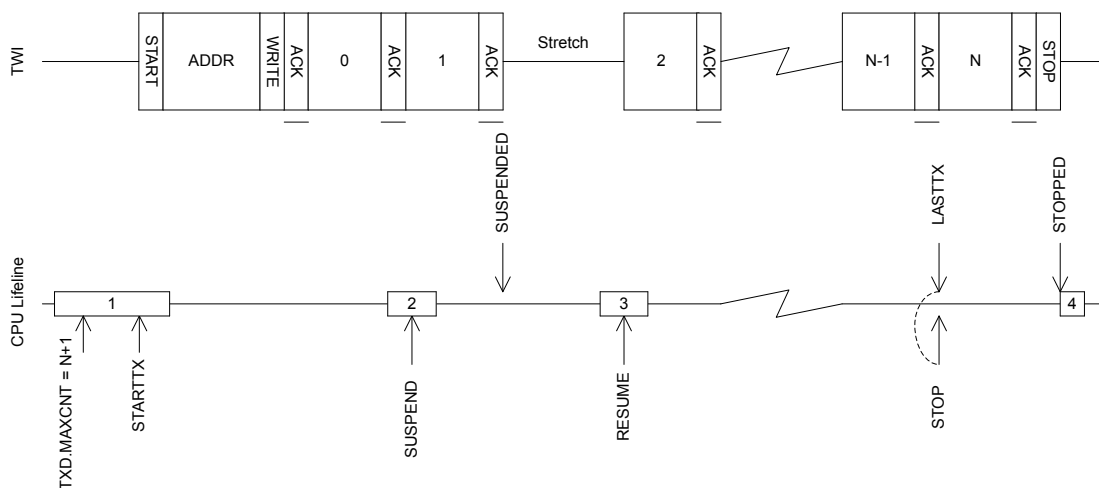

Figure 117: TWI master writing data to a slave

The TWI master will generate a LASTTX event when it starts to transmit the last byte, this is illustrated in [TWI master writing data to a slave](#) on page 319

The TWI master is stopped by triggering the STOP task, this task should be triggered during the transmission of the last byte to secure that the TWI will stop as fast as possible after sending the last byte. It is safe to use the shortcut between LASTTX and STOP to accomplish this.

Note that the TWI master does not stop by itself when the whole RAM buffer has been sent, or when an error occurs. The STOP task must be issued, through the use of a local or PPI shortcut, or in software as part of the error handler.

The TWI master cannot get stopped while it is suspended, so the STOP task has to be issued after the TWI master has been resumed.

6.25.3 Master read sequence

A TWI master read sequence is started by triggering the STARTRX task. After the STARTRX task has been triggered the TWI master will generate a start condition on the TWI bus, followed by clocking out the address and the READ/WRITE bit set to 1 (WRITE = 0, READ = 1). The address must match the address of the slave device that the master wants to read from. The READ/WRITE bit is followed by an ACK/NACK bit (ACK=0 or NACK = 1) generated by the slave.

After having sent the ACK bit the TWI slave will send data to the master using the clock generated by the master.

Data received will be stored in RAM at the address specified in the RXD.PTR register. The TWI master will generate an ACK after all but the last byte received from the slave. The TWI master will generate a NACK after the last byte received to indicate that the read sequence shall stop.

A typical TWI master read sequence is illustrated in [The TWI master reading data from a slave](#) on page 321. Occurrence 2 in the figure illustrates clock stretching performed by the TWI master following a SUSPEND task.

A SUSPENDED event indicates that the SUSPEND task has taken effect; this event can be used to synchronize the software.

The TWI master will generate a LASTRX event when it is ready to receive the last byte, this is illustrated in [The TWI master reading data from a slave](#) on page 321. If RXD.MAXCNT > 1 the LASTRX event is generated after sending the ACK of the previously received byte. If RXD.MAXCNT = 1 the LASTRX event is generated after receiving the ACK following the address and READ bit.

The TWI master is stopped by triggering the STOP task, this task must be triggered before the NACK bit is supposed to be transmitted. The STOP task can be triggered at any time during the reception of the last byte. It is safe to use the shortcut between LASTRX and STOP to accomplish this.

Note that the TWI master does not stop by itself when the RAM buffer is full, or when an error occurs. The STOP task must be issued, through the use of a local or PPI shortcut, or in software as part of the error handler.

The TWI master cannot get stopped while it is suspended, so the STOP task has to be issued after the TWI master has been resumed.

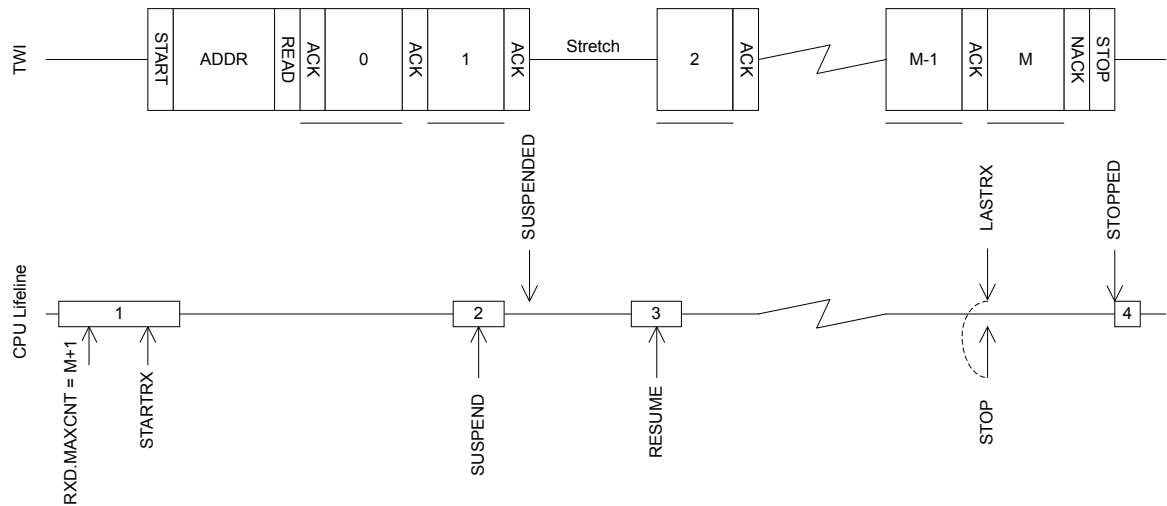

Figure 118: The TWI master reading data from a slave

6.25.4 Master repeated start sequence

A typical repeated start sequence is one in which the TWI master writes two bytes to the slave followed by reading four bytes from the slave. This example uses shortcuts to perform the simplest type of repeated start sequence, i.e. one write followed by one read. The same approach can be used to perform a repeated start sequence where the sequence is read followed by write.

The figure [A repeated start sequence, where the TWI master writes two bytes followed by reading 4 bytes from the slave](#) on page 321 illustrates this:

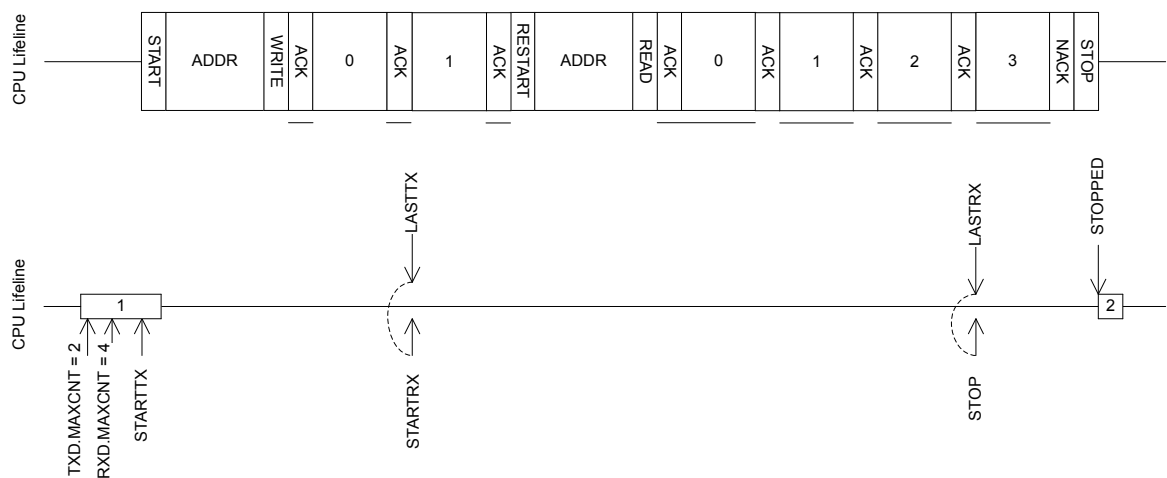

Figure 119: A repeated start sequence, where the TWI master writes two bytes followed by reading 4 bytes from the slave

If a more complex repeated start sequence is needed and the TWI firmware drive is serviced in a low priority interrupt it may be necessary to use the SUSPEND task and SUSPENDED event to guarantee that the correct tasks are generated at the correct time. This is illustrated in [A double repeated start sequence using the SUSPEND task to secure safe operation in low priority interrupts](#) on page 322.

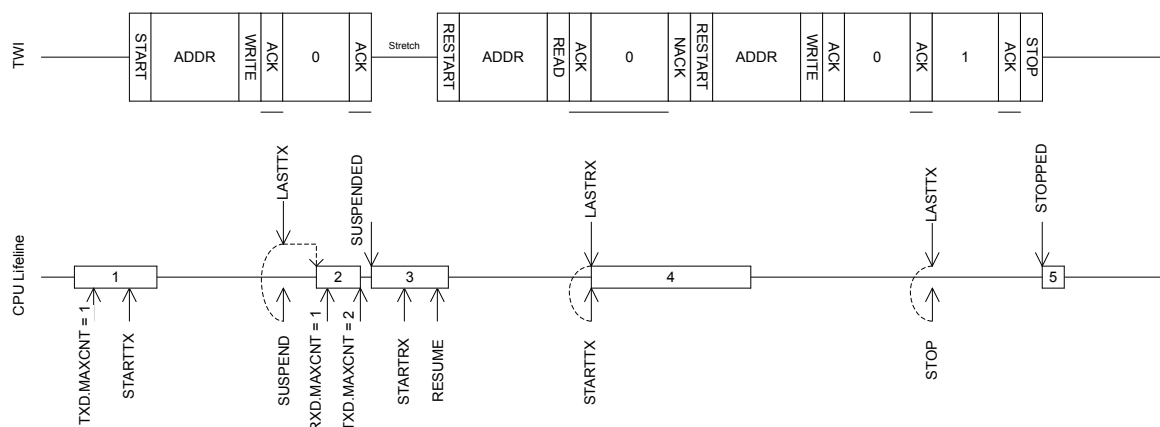

Figure 120: A double repeated start sequence using the *SUSPEND* task to secure safe operation in low priority interrupts

6.25.5 Low power

When putting the system in low power and the peripheral is not needed, lowest possible power consumption is achieved by stopping, and then disabling the peripheral.

The STOP task may not be always needed (the peripheral might already be stopped), but if it is sent, software shall wait until the STOPPED event was received as a response before disabling the peripheral through the ENABLE register.

6.25.6 Master mode pin configuration

The SCL and SDA signals associated with the TWI master are mapped to physical pins according to the configuration specified in the PSEL.SCL and PSEL.SDA registers respectively.

The PSEL.SCL and PSEL.SDA registers and their configurations are only used as long as the TWI master is enabled, and retained only as long as the device is in ON mode. When the peripheral is disabled, the pins will behave as regular GPIOs, and use the configuration in their respective OUT bit field and PIN_CNF[n] register. PSEL.SCL, PSEL.SDA must only be configured when the TWI master is disabled.

To secure correct signal levels on the pins used by the TWI master when the system is in OFF mode, and when the TWI master is disabled, these pins must be configured in the GPIO peripheral as described in [GPIO configuration before enabling peripheral](#) on page 322.

Only one peripheral can be assigned to drive a particular GPIO pin at a time. Failing to do so may result in unpredictable behavior.

TWI master signal	TWI master pin	Direction	Output value	Drive strength
SCL	As specified in PSEL.SCL	Input	Not applicable	S0D1
SDA	As specified in PSEL.SDA	Input	Not applicable	S0D1

Table 97: GPIO configuration before enabling peripheral

6.25.7 Registers

Base address	Peripheral	Instance	Description	Configuration
0x40003000	TWIM	TWIM0	Two-wire interface master	

Table 98: Instances

Register	Offset	Description
TASKS_STARTRX	0x000	Start TWI receive sequence
TASKS_STARTTX	0x008	Start TWI transmit sequence
TASKS_STOP	0x014	Stop TWI transaction. Must be issued while the TWI master is not suspended.
TASKS_SUSPEND	0x01C	Suspend TWI transaction
TASKS_RESUME	0x020	Resume TWI transaction
EVENTS_STOPPED	0x104	TWI stopped
EVENTS_ERROR	0x124	TWI error
EVENTS_SUSPENDED	0x148	Last byte has been sent out after the SUSPEND task has been issued, TWI traffic is now suspended.
EVENTS_RXSTARTED	0x14C	Receive sequence started
EVENTS_TXSTARTED	0x150	Transmit sequence started
EVENTS_LASTRX	0x15C	Byte boundary, starting to receive the last byte
EVENTS_LASTTX	0x160	Byte boundary, starting to transmit the last byte
SHORTS	0x200	Shortcuts between local events and tasks
INTEN	0x300	Enable or disable interrupt
INTENSET	0x304	Enable interrupt
INTENCLR	0x308	Disable interrupt
ERRORSRC	0x4C4	Error source
ENABLE	0x500	Enable TWIM
PSEL.SCL	0x508	Pin select for SCL signal
PSEL.SDA	0x50C	Pin select for SDA signal
FREQUENCY	0x524	TWI frequency. Accuracy depends on the HFCLK source selected.
RXD.PTR	0x534	Data pointer
RXD.MAXCNT	0x538	Maximum number of bytes in receive buffer
RXD.AMOUNT	0x53C	Number of bytes transferred in the last transaction
RXD.LIST	0x540	EasyDMA list type
TXD.PTR	0x544	Data pointer
TXD.MAXCNT	0x548	Maximum number of bytes in transmit buffer
TXD.AMOUNT	0x54C	Number of bytes transferred in the last transaction
TXD.LIST	0x550	EasyDMA list type
ADDRESS	0x588	Address used in the TWI transfer

Table 99: Register overview

6.25.7.1 TASKS_STARTRX

Address offset: 0x000

Start TWI receive sequence

Bit number	31	30	29	28	27	26	25	24	23	22	21	20	19	18	17	16	15	14	13	12	11	10	9	8	7	6	5	4	3	2	1	0					
ID																																A					
Reset 0x00000000	0	0	0	0	0	0	0	0	0	0	0	0	0	0	0	0	0	0	0	0	0	0	0	0	0	0	0	0	0	0	0	0					
ID	Acce	Field	Value	ID	Value	Description																															
A	W	TASKS_STARTRX				Start TWI receive sequence																															
			Trigger	1		Trigger task																															

6.25.7.2 TASKS_STARTTX

Address offset: 0x008

Start TWI transmit sequence

Bit number	31	30	29	28	27	26	25	24	23	22	21	20	19	18	17	16	15	14	13	12	11	10	9	8	7	6	5	4	3	2	1	0
ID																																A
Reset 0x00000000	0 0																															
ID	Acce Field	Value ID	Value	Description																												
A	W TASKS_STARTTX			Start TWI transmit sequence																												
		Trigger	1	Trigger task																												

6.25.7.3 TASKS_STOP

Address offset: 0x014

Stop TWI transaction. Must be issued while the TWI master is not suspended.

Bit number	31	30	29	28	27	26	25	24	23	22	21	20	19	18	17	16	15	14	13	12	11	10	9	8	7	6	5	4	3	2	1	0
ID																																A
Reset 0x00000000	0 0																															
ID	Acce Field	Value ID	Value	Description																												
A	W TASKS_STOP			Stop TWI transaction. Must be issued while the TWI master is not suspended.																												
		Trigger	1	Trigger task																												

6.25.7.4 TASKS_SUSPEND

Address offset: 0x01C

Suspend TWI transaction

Bit number	31	30	29	28	27	26	25	24	23	22	21	20	19	18	17	16	15	14	13	12	11	10	9	8	7	6	5	4	3	2	1	0
ID																																A
Reset 0x00000000	0 0																															
ID	Acce Field	Value ID	Value	Description																												
A	W TASKS_SUSPEND			Suspend TWI transaction																												
		Trigger	1	Trigger task																												

6.25.7.5 TASKS_RESUME

Address offset: 0x020

Resume TWI transaction

Bit number	31	30	29	28	27	26	25	24	23	22	21	20	19	18	17	16	15	14	13	12	11	10	9	8	7	6	5	4	3	2	1	0
ID																																A
Reset 0x00000000	0 0																															
ID	Acce Field	Value ID	Value	Description																												
A	W TASKS_RESUME			Resume TWI transaction																												
		Trigger	1	Trigger task																												

6.25.7.6 EVENTS_STOPPED

Address offset: 0x104

TWI stopped

Bit number	31	30	29	28	27	26	25	24	23	22	21	20	19	18	17	16	15	14	13	12	11	10	9	8	7	6	5	4	3	2	1	0
ID																																A
Reset	0x00000000																															
	0 0																															
ID	Acce Field	Value ID	Value	Description																												
A	RW EVENTS_STOPPED			TWI stopped																												
		NotGenerated	0	Event not generated																												
		Generated	1	Event generated																												

6.25.7.7 EVENTS_ERROR

Address offset: 0x124

TWI error

Bit number	31	30	29	28	27	26	25	24	23	22	21	20	19	18	17	16	15	14	13	12	11	10	9	8	7	6	5	4	3	2	1	0
ID																																A
Reset	0x00000000																															
	0 0																															
ID	Acce Field	Value ID	Value	Description																												
A	RW EVENTS_ERROR			TWI error																												
		NotGenerated	0	Event not generated																												
		Generated	1	Event generated																												

6.25.7.8 EVENTS_SUSPENDED

Address offset: 0x148

Last byte has been sent out after the SUSPEND task has been issued, TWI traffic is now suspended.

Bit number	31	30	29	28	27	26	25	24	23	22	21	20	19	18	17	16	15	14	13	12	11	10	9	8	7	6	5	4	3	2	1	0
ID																																A
Reset	0x00000000																															
	0 0																															
ID	Acce Field	Value ID	Value	Description																												
A	RW EVENTS_SUSPENDED			Last byte has been sent out after the SUSPEND task has been issued, TWI traffic is now suspended.																												
		NotGenerated	0	Event not generated																												
		Generated	1	Event generated																												

6.25.7.9 EVENTS_RXSTARTED

Address offset: 0x14C

Receive sequence started

Bit number	31	30	29	28	27	26	25	24	23	22	21	20	19	18	17	16	15	14	13	12	11	10	9	8	7	6	5	4	3	2	1	0
ID																																A
Reset	0x00000000																															
	0 0																															
ID	Acce Field	Value ID	Value	Description																												
A	RW EVENTS_RXSTARTED			Receive sequence started																												
		NotGenerated	0	Event not generated																												
		Generated	1	Event generated																												

6.25.7.10 EVENTS_TXSTARTED

Address offset: 0x150

Transmit sequence started

Bit number	31	30	29	28	27	26	25	24	23	22	21	20	19	18	17	16	15	14	13	12	11	10	9	8	7	6	5	4	3	2	1	0
ID																																A
Reset 0x00000000	0 0																															
ID	Acce Field	Value ID	Value	Description																												
A	RW EVENTS_TXSTARTED			Transmit sequence started																												
		NotGenerated	0	Event not generated																												
		Generated	1	Event generated																												

6.25.7.11 EVENTS_LASTRX

Address offset: 0x15C

Byte boundary, starting to receive the last byte

Bit number	31	30	29	28	27	26	25	24	23	22	21	20	19	18	17	16	15	14	13	12	11	10	9	8	7	6	5	4	3	2	1	0
ID																																A
Reset 0x00000000	0 0																															
ID	Acce Field	Value ID	Value	Description																												
A	RW EVENTS_LASTRX			Byte boundary, starting to receive the last byte																												
		NotGenerated	0	Event not generated																												
		Generated	1	Event generated																												

6.25.7.12 EVENTS_LASTTX

Address offset: 0x160

Byte boundary, starting to transmit the last byte

Bit number	31	30	29	28	27	26	25	24	23	22	21	20	19	18	17	16	15	14	13	12	11	10	9	8	7	6	5	4	3	2	1	0
ID																																A
Reset 0x00000000	0 0																															
ID	Acce Field	Value ID	Value	Description																												
A	RW EVENTS_LASTTX			Byte boundary, starting to transmit the last byte																												
		NotGenerated	0	Event not generated																												
		Generated	1	Event generated																												

6.25.7.13 SHORTS

Address offset: 0x200

Shortcuts between local events and tasks

Bit number	31	30	29	28	27	26	25	24	23	22	21	20	19	18	17	16	15	14	13	12	11	10	9	8	7	6	5	4	3	2	1	0
ID												F	E	D	C	B	A															
Reset 0x00000000	0 0																															
ID	Acce Field	Value ID	Value	Description																												
A	RW LASTTX_STARTRX			Shortcut between event LASTTX and task STARTRX																												
		Disabled	0	Disable shortcut																												
		Enabled	1	Enable shortcut																												
B	RW LASTTX_SUSPEND			Shortcut between event LASTTX and task SUSPEND																												
		Disabled	0	Disable shortcut																												
		Enabled	1	Enable shortcut																												
C	RW LASTTX_STOP			Shortcut between event LASTTX and task STOP																												
		Disabled	0	Disable shortcut																												
		Enabled	1	Enable shortcut																												

Bit number	31 30 29 28 27 26 25 24 23 22 21 20 19 18 17 16 15 14 13 12 11 10 9 8 7 6 5 4 3 2 1 0																														
ID	F E D C B A																														
Reset 0x00000000	0 0																														
ID	Acce	Field	Value ID	Value	Description																										
D	RW	LASTRX_STARTTX			Shortcut between event LASTRX and task STARTTX																										
			Disabled	0	Disable shortcut																										
			Enabled	1	Enable shortcut																										
E	RW	LASTRX_SUSPEND			Shortcut between event LASTRX and task SUSPEND																										
			Disabled	0	Disable shortcut																										
			Enabled	1	Enable shortcut																										
F	RW	LASTRX_STOP			Shortcut between event LASTRX and task STOP																										
			Disabled	0	Disable shortcut																										
			Enabled	1	Enable shortcut																										

6.25.7.14 INTEN

Address offset: 0x300

Enable or disable interrupt

Bit number	31 30 29 28 27 26 25 24 23 22 21 20 19 18 17 16 15 14 13 12 11 10 9 8 7 6 5 4 3 2 1 0																														
ID	J I H G F D A																														
Reset 0x00000000	0 0																														
ID	Acce	Field	Value ID	Value	Description																										
A	RW	STOPPED			Enable or disable interrupt for event STOPPED																										
			Disabled	0	Disable																										
			Enabled	1	Enable																										
D	RW	ERROR			Enable or disable interrupt for event ERROR																										
			Disabled	0	Disable																										
			Enabled	1	Enable																										
F	RW	SUSPENDED			Enable or disable interrupt for event SUSPENDED																										
			Disabled	0	Disable																										
			Enabled	1	Enable																										
G	RW	RXSTARTED			Enable or disable interrupt for event RXSTARTED																										
			Disabled	0	Disable																										
			Enabled	1	Enable																										
H	RW	TXSTARTED			Enable or disable interrupt for event TXSTARTED																										
			Disabled	0	Disable																										
			Enabled	1	Enable																										
I	RW	LASTRX			Enable or disable interrupt for event LASTRX																										
			Disabled	0	Disable																										
			Enabled	1	Enable																										
J	RW	LASTTX			Enable or disable interrupt for event LASTTX																										
			Disabled	0	Disable																										
			Enabled	1	Enable																										

6.25.7.15 INTENSET

Address offset: 0x304

Enable interrupt

Bit number		31 30 29 28 27 26 25 24 23 22 21 20 19 18 17 16 15 14 13 12 11 10 9 8 7 6 5 4 3 2 1 0																											
ID		J I H G F										D										A							
Reset 0x00000000		0 0																											
ID	Acce Field	Value ID	Value	Description																									
A	RW STOPPED			Write '1' to enable interrupt for event STOPPED																									
		Set	1	Enable																									
		Disabled	0	Read: Disabled																									
		Enabled	1	Read: Enabled																									
D	RW ERROR			Write '1' to enable interrupt for event ERROR																									
		Set	1	Enable																									
		Disabled	0	Read: Disabled																									
		Enabled	1	Read: Enabled																									
F	RW SUSPENDED			Write '1' to enable interrupt for event SUSPENDED																									
		Set	1	Enable																									
		Disabled	0	Read: Disabled																									
		Enabled	1	Read: Enabled																									
G	RW RXSTARTED			Write '1' to enable interrupt for event RXSTARTED																									
		Set	1	Enable																									
		Disabled	0	Read: Disabled																									
		Enabled	1	Read: Enabled																									
H	RW TXSTARTED			Write '1' to enable interrupt for event TXSTARTED																									
		Set	1	Enable																									
		Disabled	0	Read: Disabled																									
		Enabled	1	Read: Enabled																									
I	RW LASTRX			Write '1' to enable interrupt for event LASTRX																									
		Set	1	Enable																									
		Disabled	0	Read: Disabled																									
		Enabled	1	Read: Enabled																									
J	RW LASTTX			Write '1' to enable interrupt for event LASTTX																									
		Set	1	Enable																									
		Disabled	0	Read: Disabled																									
		Enabled	1	Read: Enabled																									

6.25.7.16 INTENCLR

Address offset: 0x308

Disable interrupt

Bit number		31 30 29 28 27 26 25 24 23 22 21 20 19 18 17 16 15 14 13 12 11 10 9 8 7 6 5 4 3 2 1 0																											
ID		J I H G F										D										A							
Reset 0x00000000		0 0																											
ID	Acce Field	Value ID	Value	Description																									
A	RW STOPPED			Write '1' to disable interrupt for event STOPPED																									
		Clear	1	Disable																									
		Disabled	0	Read: Disabled																									
		Enabled	1	Read: Enabled																									
D	RW ERROR			Write '1' to disable interrupt for event ERROR																									
		Clear	1	Disable																									
		Disabled	0	Read: Disabled																									
		Enabled	1	Read: Enabled																									
F	RW SUSPENDED			Write '1' to disable interrupt for event SUSPENDED																									
		Clear	1	Disable																									
		Disabled	0	Read: Disabled																									

Bit number	31	30	29	28	27	26	25	24	23	22	21	20	19	18	17	16	15	14	13	12	11	10	9	8	7	6	5	4	3	2	1	0
ID																												A	A	A	A	
Reset 0x00000000	0 0																															
ID	Acce Field	Value ID	Value	Description																												
A	RW ENABLE			Enable or disable TWIM																												
		Disabled	0	Disable TWIM																												
		Enabled	6	Enable TWIM																												

6.25.7.19 PSEL.SCL

Address offset: 0x508

Pin select for SCL signal

Bit number	31	30	29	28	27	26	25	24	23	22	21	20	19	18	17	16	15	14	13	12	11	10	9	8	7	6	5	4	3	2	1	0
ID	C																											A	A	A	A	A
Reset 0xFFFFFFFF	1 1																															
ID	Acce Field	Value ID	Value	Description																												
A	RW PIN		[0..31]	Pin number																												
C	RW CONNECT			Connection																												
		Disconnected	1	Disconnect																												
		Connected	0	Connect																												

6.25.7.20 PSEL.SDA

Address offset: 0x50C

Pin select for SDA signal

Bit number	31	30	29	28	27	26	25	24	23	22	21	20	19	18	17	16	15	14	13	12	11	10	9	8	7	6	5	4	3	2	1	0
ID	C																											A	A	A	A	A
Reset 0xFFFFFFFF	1 1																															
ID	Acce Field	Value ID	Value	Description																												
A	RW PIN		[0..31]	Pin number																												
C	RW CONNECT			Connection																												
		Disconnected	1	Disconnect																												
		Connected	0	Connect																												

6.25.7.21 FREQUENCY

Address offset: 0x524

TWI frequency. Accuracy depends on the HFCLK source selected.

Bit number	31	30	29	28	27	26	25	24	23	22	21	20	19	18	17	16	15	14	13	12	11	10	9	8	7	6	5	4	3	2	1	0
ID	A	A	A	A	A	A	A	A	A	A	A	A	A	A	A	A	A	A	A	A	A	A	A	A	A	A	A	A	A	A	A	
Reset 0x04000000	0 0 0 0 0 1 0																															
ID	Acce Field	Value ID	Value	Description																												
A	RW FREQUENCY			TWI master clock frequency																												
		K100	0x01980000	100 kbps																												
		K250	0x04000000	250 kbps																												
		K400	0x06400000	400 kbps																												

6.25.7.22 RXD.PTR

Address offset: 0x534

Data pointer

Bit number	31	30	29	28	27	26	25	24	23	22	21	20	19	18	17	16	15	14	13	12	11	10	9	8	7	6	5	4	3	2	1	0
ID	A	A	A	A	A	A	A	A	A	A	A	A	A	A	A	A	A	A	A	A	A	A	A	A	A	A	A	A	A	A	A	A
Reset 0x00000000	0	0	0	0	0	0	0	0	0	0	0	0	0	0	0	0	0	0	0	0	0	0	0	0	0	0	0	0	0	0	0	0
ID	Acce Field	Value ID	Value	Description																												
A	RW	PTR		Data pointer																												

Note: See the memory chapter for details about which memories are available for EasyDMA.

6.25.7.23 RXD.MAXCNT

Address offset: 0x538

Maximum number of bytes in receive buffer

Bit number	31	30	29	28	27	26	25	24	23	22	21	20	19	18	17	16	15	14	13	12	11	10	9	8	7	6	5	4	3	2	1	0
ID																								A	A	A	A	A	A	A	A	A
Reset 0x00000000	0	0	0	0	0	0	0	0	0	0	0	0	0	0	0	0	0	0	0	0	0	0	0	0	0	0	0	0	0	0	0	0
ID	Acce Field	Value ID	Value	Description																												
A	RW	MAXCNT	[1..0x3FF]	Maximum number of bytes in receive buffer																												

6.25.7.24 RXD.AMOUNT

Address offset: 0x53C

Number of bytes transferred in the last transaction

Bit number	31	30	29	28	27	26	25	24	23	22	21	20	19	18	17	16	15	14	13	12	11	10	9	8	7	6	5	4	3	2	1	0	
ID																									A	A	A	A	A	A	A	A	A
Reset 0x00000000	0	0	0	0	0	0	0	0	0	0	0	0	0	0	0	0	0	0	0	0	0	0	0	0	0	0	0	0	0	0	0	0	
ID	Acce Field	Value ID	Value	Description																													
A	R	AMOUNT	[1..0x3FF]	Number of bytes transferred in the last transaction. In case of NACK error, includes the NACK'ed byte.																													

6.25.7.25 RXD.LIST

Address offset: 0x540

EasyDMA list type

Bit number	31	30	29	28	27	26	25	24	23	22	21	20	19	18	17	16	15	14	13	12	11	10	9	8	7	6	5	4	3	2	1	0		
ID																																A	A	A
Reset 0x00000000	0	0	0	0	0	0	0	0	0	0	0	0	0	0	0	0	0	0	0	0	0	0	0	0	0	0	0	0	0	0	0	0	0	
ID	Acce Field	Value ID	Value	Description																														
A	RW	LIST		List type																														
		Disabled	0	Disable EasyDMA list																														
		ArrayList	1	Use array list																														

6.25.7.26 TXD.PTR

Address offset: 0x544

Data pointer

Bit number	31	30	29	28	27	26	25	24	23	22	21	20	19	18	17	16	15	14	13	12	11	10	9	8	7	6	5	4	3	2	1	0
ID	A	A	A	A	A	A	A	A	A	A	A	A	A	A	A	A	A	A	A	A	A	A	A	A	A	A	A	A	A	A	A	A
Reset 0x00000000	0	0	0	0	0	0	0	0	0	0	0	0	0	0	0	0	0	0	0	0	0	0	0	0	0	0	0	0	0	0	0	0
ID	Acce	Field	Value ID	Value	Description																											
A	RW	PTR			Data pointer																											

Note: See the memory chapter for details about which memories are available for EasyDMA.

6.25.7.27 TXD.MAXCNT

Address offset: 0x548

Maximum number of bytes in transmit buffer

Bit number	31	30	29	28	27	26	25	24	23	22	21	20	19	18	17	16	15	14	13	12	11	10	9	8	7	6	5	4	3	2	1	0																			
ID																							A	A	A	A	A	A	A	A	A	A	A	A	A	A	A	A	A	A	A	A	A	A	A	A	A	A	A	A	A
Reset 0x00000000	0	0	0	0	0	0	0	0	0	0	0	0	0	0	0	0	0	0	0	0	0	0	0	0	0	0	0	0	0	0	0	0																			
ID	Acce	Field	Value ID	Value	Description																																														
A	RW	MAXCNT		[1..0x3FF]	Maximum number of bytes in transmit buffer																																														

6.25.7.28 TXD.AMOUNT

Address offset: 0x54C

Number of bytes transferred in the last transaction

Bit number	31	30	29	28	27	26	25	24	23	22	21	20	19	18	17	16	15	14	13	12	11	10	9	8	7	6	5	4	3	2	1	0																			
ID																							A	A	A	A	A	A	A	A	A	A	A	A	A	A	A	A	A	A	A	A	A	A	A	A	A	A	A	A	A
Reset 0x00000000	0	0	0	0	0	0	0	0	0	0	0	0	0	0	0	0	0	0	0	0	0	0	0	0	0	0	0	0	0	0	0	0																			
ID	Acce	Field	Value ID	Value	Description																																														
A	R	AMOUNT		[1..0x3FF]	Number of bytes transferred in the last transaction. In case of NACK error, includes the NACK'ed byte.																																														

6.25.7.29 TXD.LIST

Address offset: 0x550

EasyDMA list type

Bit number	31	30	29	28	27	26	25	24	23	22	21	20	19	18	17	16	15	14	13	12	11	10	9	8	7	6	5	4	3	2	1	0
ID																										A	A	A				
Reset 0x00000000	0	0	0	0	0	0	0	0	0	0	0	0	0	0	0	0	0	0	0	0	0	0	0	0	0	0	0	0	0	0	0	
ID	Acce	Field	Value ID	Value	Description																											
A	RW	LIST			List type																											
			Disabled	0	Disable EasyDMA list																											
			ArrayList	1	Use array list																											

6.25.7.30 ADDRESS

Address offset: 0x588

Address used in the TWI transfer

Bit number	31	30	29	28	27	26	25	24	23	22	21	20	19	18	17	16	15	14	13	12	11	10	9	8	7	6	5	4	3	2	1	0
ID	A A A A A A A																															
Reset 0x00000000	0 0																															
ID	Acce	Field	Value	ID	Value	Description																										
A	RW	ADDRESS				Address used in the TWI transfer																										

6.25.8 Electrical specification

6.25.8.1 TWIM interface electrical specifications

Symbol	Description	Min.	Typ.	Max.	Units
$f_{TWIM,SCL}$	Bit rates for TWIM ³⁰	100		400	kbps
$t_{TWIM,START}$	Time from STARTRX/STARTTX task to transmission started	μ s

6.25.8.2 Two Wire Interface Master (TWIM) timing specifications

Symbol	Description	Min.	Typ.	Max.	Units
$t_{TWIM,SU,DAT}$	Data setup time before positive edge on SCL – all modes	300			ns
$t_{TWIM,HD,DAT}$	Data hold time after negative edge on SCL – all modes	500			ns
$t_{TWIM,HD,STA,100kbps}$	TWIM master hold time for START and repeated START condition, 100 kbps	10000			ns
$t_{TWIM,HD,STA,250kbps}$	TWIM master hold time for START and repeated START condition, 250kbps	4000			ns
$t_{TWIM,HD,STA,400kbps}$	TWIM master hold time for START and repeated START condition, 400 kbps	2500			ns
$t_{TWIM,SU,STO,100kbps}$	TWIM master setup time from SCL high to STOP condition, 100 kbps	5000			ns
$t_{TWIM,SU,STO,250kbps}$	TWIM master setup time from SCL high to STOP condition, 250 kbps	2000			ns
$t_{TWIM,SU,STO,400kbps}$	TWIM master setup time from SCL high to STOP condition, 400 kbps	1250			ns
$t_{TWIM,BUF,100kbps}$	TWIM master bus free time between STOP and START conditions, 100 kbps	5800			ns
$t_{TWIM,BUF,250kbps}$	TWIM master bus free time between STOP and START conditions, 250 kbps	2700			ns
$t_{TWIM,BUF,400kbps}$	TWIM master bus free time between STOP and START conditions, 400 kbps	2100			ns

³⁰ High bit rates or stronger pull-ups may require GPIOs to be set as High Drive, see GPIO chapter for more details.

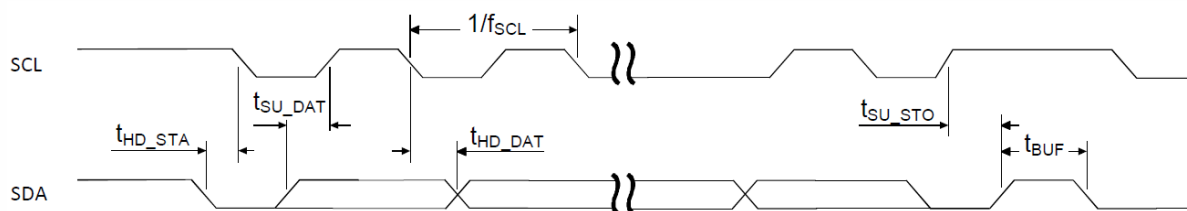

Figure 121: TWIM timing diagram, 1 byte transaction

6.25.9 Pullup resistor

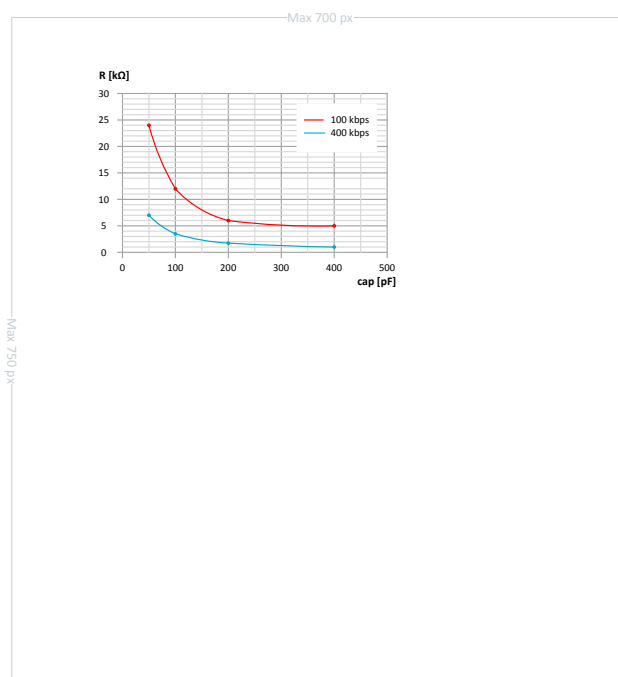

Figure 122: Recommended TWIM pullup value vs. line capacitance

- The I2C specification allows a line capacitance of 400 pF at most.
- The value of internal pullup resistor (R_{PU}) for nRF52810 can be found in [GPIO — General purpose input/output](#) on page 116.

6.26 TWIS — I²C compatible two-wire interface slave with EasyDMA

TWI slave with EasyDMA (TWIS) is compatible with I²C operating at 100 kHz and 400 kHz. The TWI transmitter and receiver implement EasyDMA.

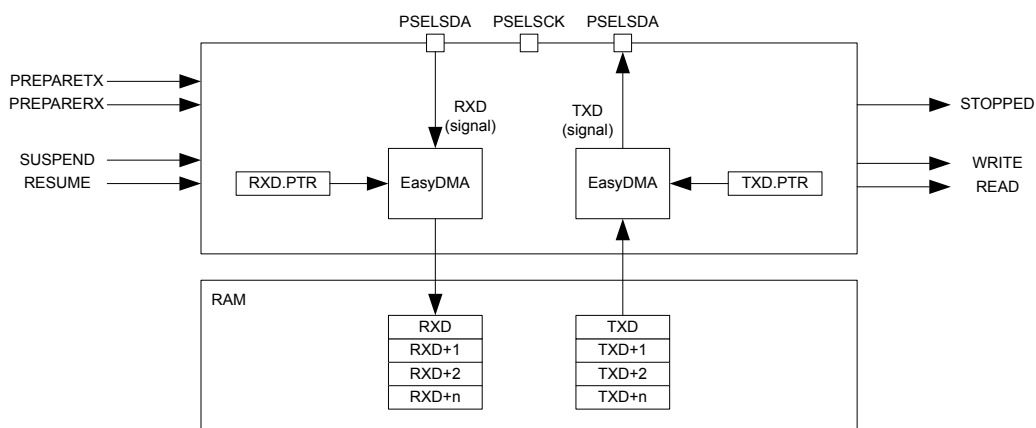

Figure 123: TWI slave with EasyDMA

A typical TWI setup consists of one master and one or more slaves. For an example, see [A typical TWI setup comprising one master and three slaves](#) on page 335. TWIS is only able to operate with a single master on the TWI bus.

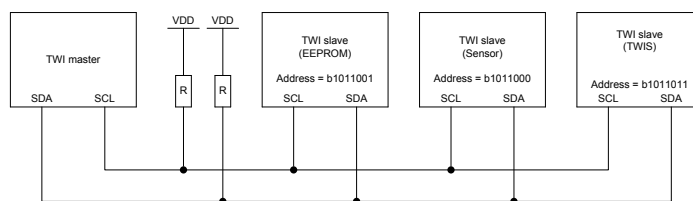

Figure 124: A typical TWI setup comprising one master and three slaves

The TWI slave state machine is illustrated in [TWI slave state machine](#) on page 336 and [TWI slave state machine symbols](#) on page 336 is explaining the different symbols used in the state machine.

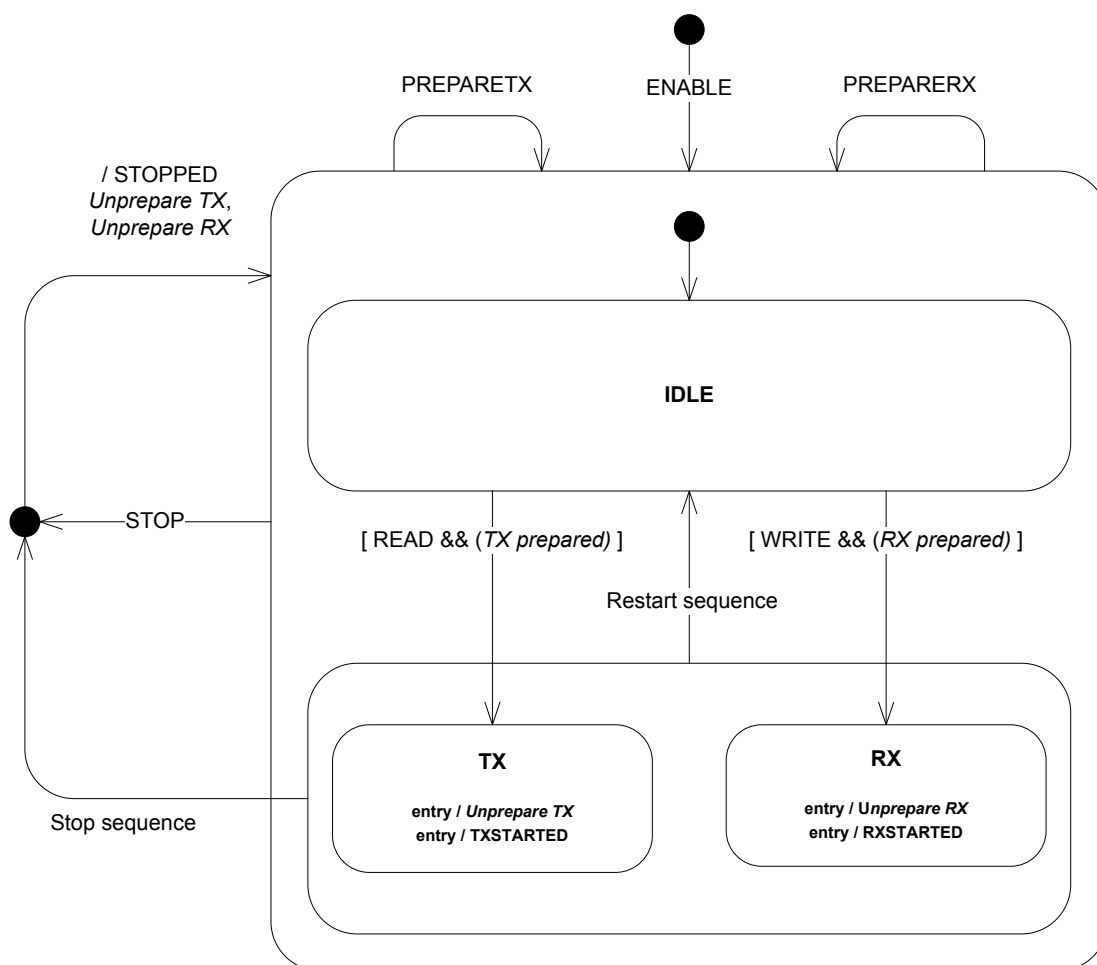

Figure 125: TWI slave state machine

Symbol	Type	Description
ENABLE	Register	The TWI slave has been enabled via the <code>ENABLE</code> register
PREPARETX	Task	The <code>TASKS_PREPARETX</code> task has been triggered
STOP	Task	The <code>TASKS_STOP</code> task has been triggered
PREPARERX	Task	The <code>TASKS_PREPARERX</code> task has been triggered
STOPPED	Event	The <code>EVENTS_STOPPED</code> event was generated
RXSTARTED	Event	The <code>EVENTS_RXSTARTED</code> event was generated
TXSTARTED	Event	The <code>EVENTS_TXSTARTED</code> event was generated
TX prepared	Internal	Internal flag indicating that a <code>TASKS_PREPARETX</code> task has been triggered. This flag is not visible to the user.
RX prepared	Internal	Internal flag indicating that a <code>TASKS_PREPARERX</code> task has been triggered. This flag is not visible to the user.
Unprepare TX	Internal	Clears the internal 'TX prepared' flag until next <code>TASKS_PREPARETX</code> task.
Unprepare RX	Internal	Clears the internal 'RX prepared' flag until next <code>TASKS_PREPARERX</code> task.
Stop sequence	TWI protocol	A TWI stop sequence was detected
Restart sequence	TWI protocol	A TWI restart sequence was detected

Table 100: TWI slave state machine symbols

The TWI slave supports clock stretching performed by the master.

The TWI slave operates in a low power mode while waiting for a TWI master to initiate a transfer. As long as the TWI slave is not addressed, it will remain in this low power mode.

To secure correct behaviour of the TWI slave, PSEL.SCL, PSEL.SDA, CONFIG and the ADDRESS[n] registers, must be configured prior to enabling the TWI slave through the ENABLE register. Similarly, changing these settings must be performed while the TWI slave is disabled. Failing to do so may result in unpredictable behaviour.

6.26.1 EasyDMA

The TWIS implements EasyDMA for accessing RAM without CPU involvement.

The TWIS peripheral implements the following EasyDMA channels:

Channel	Type	Register Cluster
TXD	READER	TXD
RXD	WRITER	RXD

Table 101: TWIS EasyDMA Channels

For detailed information regarding the use of EasyDMA, see [EasyDMA](#) on page 36.

The STOPPED event indicates that EasyDMA has finished accessing the buffer in RAM.

6.26.2 TWI slave responding to a read command

Before the TWI slave can respond to a read command the TWI slave must be configured correctly and enabled via the ENABLE register. When enabled the TWI slave will be in its IDLE state where it will consume I_{IDLE} .

A read command is started when the TWI master generates a start condition on the TWI bus, followed by clocking out the address and the READ/WRITE bit set to 1 (WRITE=0, READ=1). The READ/WRITE bit is followed by an ACK/NACK bit (ACK=0 or NACK=1) response from the TWI slave.

The TWI slave is able to listen for up to two addresses at the same time. Which addresses to listen for is configured in the ADDRESS registers and the CONFIG register.

The TWI slave will only acknowledge (ACK) the read command if the address presented by the master matches one of the addresses the slave is configured to listen for. The TWI slave will generate a READ event when it acknowledges the read command.

The TWI slave is only able to detect a read command from the IDLE state.

The TWI slave will set an internal 'TX prepared' flag when the PREPARETX task is triggered.

When the read command is received the TWI slave will enter the TX state if the internal 'TX prepared' flag is set.

If the internal 'TX prepared' flag is not set when the read command is received, the TWI slave will stretch the master's clock until the PREPARETX task is triggered and the internal 'TX prepared' flag is set.

The TWI slave will generate the TXSTARTED event and clear the 'TX prepared' flag ('unprepare TX') when it enters the TX state. In this state the TWI slave will send the data bytes found in the transmit buffer to the master using the master's clock. The TWI slave will consume I_{TX} in this mode.

The TWI slave will go back to the IDLE state if the TWI slave receives a restart command when it is in the TX state.

The TWI slave is stopped when it receives the stop condition from the TWI master. A STOPPED event will be generated when the transaction has stopped. The TWI slave will clear the 'TX prepared' flag ('unprepare TX') and go back to the IDLE state when it has stopped.

The transmit buffer is located in RAM at the address specified in the TXD.PTR register. The TWI slave will only be able to send TXD.MAXCNT bytes from the transmit buffer for each transaction. If the TWI master forces the slave to send more than TXD.MAXCNT bytes, the slave will send the byte specified in the ORC register to the master instead. If this happens, an ERROR event will be generated.

The EasyDMA configuration registers, see TXD.PTR etc., are latched when the TXSTARTED event is generated.

The TWI slave can be forced to stop by triggering the STOP task. A STOPPED event will be generated when the TWI slave has stopped. The TWI slave will clear the 'TX prepared' flag and go back to the IDLE state when it has stopped, see also [Terminating an ongoing TWI transaction](#) on page 340.

Each byte sent from the slave will be followed by an ACK/NACK bit sent from the master. The TWI master will generate a NACK following the last byte that it wants to receive to tell the slave to release the bus so that the TWI master can generate the stop condition. The TXD.AMOUNT register can be queried after a transaction to see how many bytes were sent.

A typical TWI slave read command response is illustrated in [The TWI slave responding to a read command](#) on page 338. Occurrence 2 in the figure illustrates clock stretching performed by the TWI slave following a SUSPEND task.

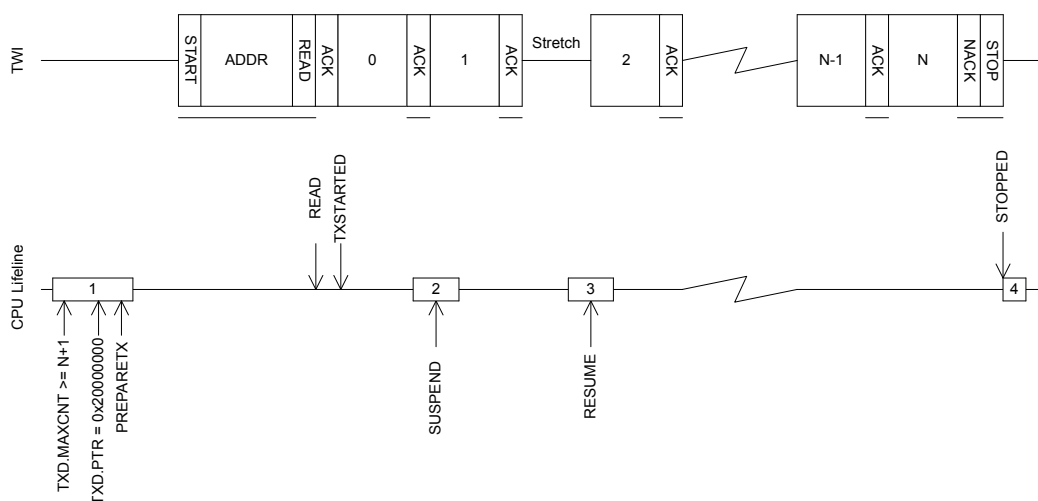

Figure 126: The TWI slave responding to a read command

6.26.3 TWI slave responding to a write command

Before the TWI slave can respond to a write command the TWI slave must be configured correctly and enabled via the ENABLE register. When enabled the TWI slave will be in its IDLE state where it will consume I_{IDLE} .

A write command is started when the TWI master generates a start condition on the TWI bus, followed by clocking out the address and the READ/WRITE bit set to 0 (WRITE=0, READ=1). The READ/WRITE bit is followed by an ACK/NACK bit (ACK=0 or NACK=1) response from the slave.

The TWI slave is able to listen for up to two addresses at the same time. Which addresses to listen for is configured in the ADDRESS registers and the CONFIG register.

The TWI slave will only acknowledge (ACK) the write command if the address presented by the master matches one of the addresses the slave is configured to listen for. The TWI slave will generate a WRITE event if it acknowledges the write command.

The TWI slave is only able to detect a write command from the IDLE state.

The TWI slave will set an internal 'RX prepared' flag when the PREPARERX task is triggered.

When the write command is received the TWI slave will enter the RX state if the internal 'RX prepared' flag is set.

If the internal 'RX prepared' flag is not set when the write command is received, the TWI slave will stretch the master's clock until the PREPARERX task is triggered and the internal 'RX prepared' flag is set.

The TWI slave will generate the RXSTARTED event and clear the internal 'RX prepared' flag ('unprepare RX') when it enters the RX state. In this state the TWI slave will be able to receive the bytes sent by the TWI master. The TWI slave will consume I_{RX} in this mode.

The TWI slave will go back to the IDLE state if the TWI slave receives a restart command when it is in the RX state.

The TWI slave is stopped when it receives the stop condition from the TWI master. A STOPPED event will be generated when the transaction has stopped. The TWI slave will clear the internal 'RX prepared' flag ('unprepare RX') and go back to the IDLE state when it has stopped.

The receive buffer is located in RAM at the address specified in the TXD.PTR register. The TWI slave will only be able to receive as many bytes as specified in the RXD.MAXCNT register. If the TWI master tries to send more bytes to the slave than the slave is able to receive, these bytes will be discarded and the bytes will be NACKed by the slave. If this happens, an ERROR event will be generated.

The EasyDMA configuration registers, see RXD.PTR etc., are latched when the RXSTARTED event is generated.

The TWI slave can be forced to stop by triggering the STOP task. A STOPPED event will be generated when the TWI slave has stopped. The TWI slave will clear the internal 'RX prepared' flag and go back to the IDLE state when it has stopped, see also [Terminating an ongoing TWI transaction](#) on page 340.

The TWI slave will generate an ACK after every byte received from the master. The RXD.AMOUNT register can be queried after a transaction to see how many bytes were received.

A typical TWI slave write command response is illustrated in [The TWI slave responding to a write command](#) on page 339. Occurrence 2 in the figure illustrates clock stretching performed by the TWI slave following a SUSPEND task.

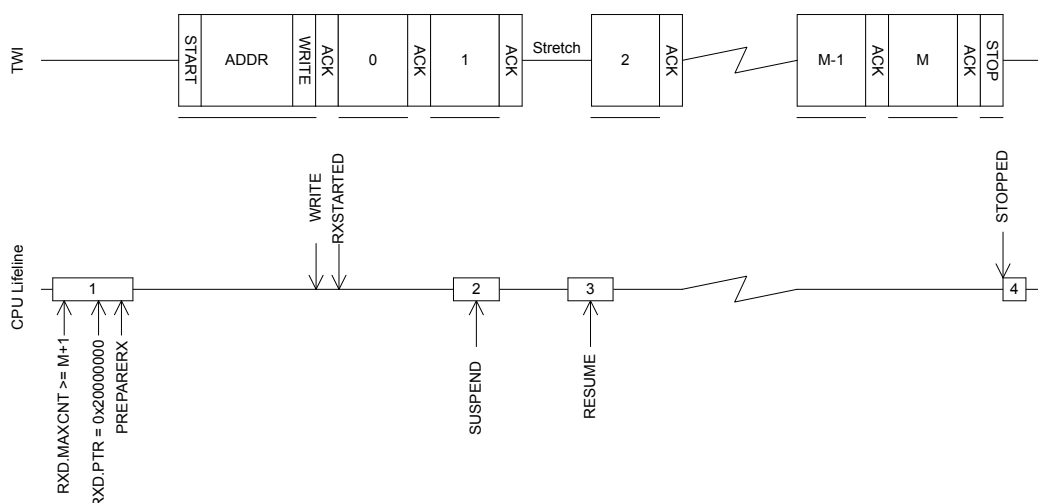

Figure 127: The TWI slave responding to a write command

6.26.4 Master repeated start sequence

An example of a repeated start sequence is one in which the TWI master writes two bytes to the slave followed by reading four bytes from the slave.

This is illustrated in [A repeated start sequence, where the TWI master writes two bytes followed by reading four bytes from the slave](#) on page 340.

It is here assumed that the receiver does not know in advance what the master wants to read, and that this information is provided in the first two bytes received in the write part of the repeated start sequence. To guarantee that the CPU is able to process the received data before the TWI slave starts to reply to the read command, the SUSPEND task is triggered via a shortcut from the READ event generated when the read command is received. When the CPU has processed the incoming data and prepared the correct data response, the CPU will resume the transaction by triggering the RESUME task.

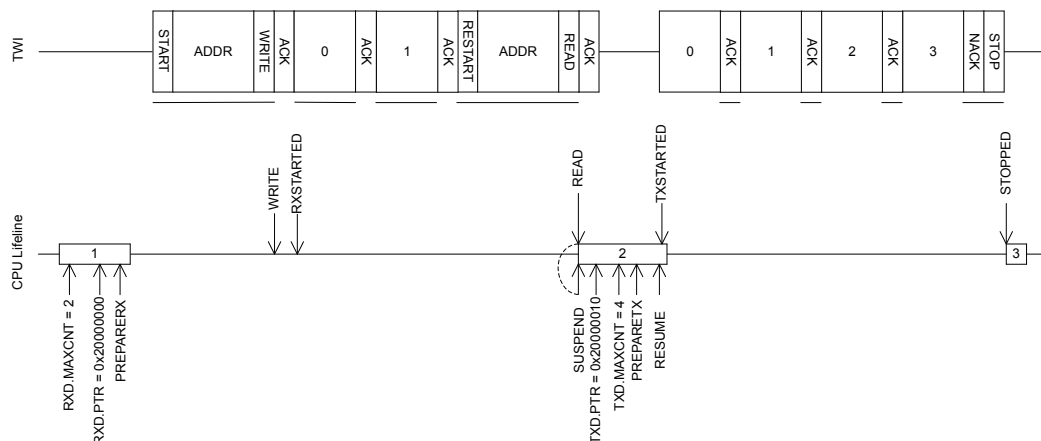

Figure 128: A repeated start sequence, where the TWI master writes two bytes followed by reading four bytes from the slave

6.26.5 Terminating an ongoing TWI transaction

In some situations, e.g. if the external TWI master is not responding correctly, it may be required to terminate an ongoing transaction.

This can be achieved by triggering the STOP task. In this situation a STOPPED event will be generated when the TWI has stopped independent of whether or not a STOP condition has been generated on the TWI bus. The TWI slave will release the bus when it has stopped and go back to its IDLE state.

6.26.6 Low power

When putting the system in low power and the peripheral is not needed, lowest possible power consumption is achieved by stopping, and then disabling the peripheral.

The STOP task may not be always needed (the peripheral might already be stopped), but if it is sent, software shall wait until the STOPPED event was received as a response before disabling the peripheral through the ENABLE register.

6.26.7 Slave mode pin configuration

The SCL and SDA signals associated with the TWI slave are mapped to physical pins according to the configuration specified in the PSEL.SCL and PSEL.SDA registers respectively.

The PSEL.SCL and PSEL.SDA registers and their configurations are only used as long as the TWI slave is enabled, and retained only as long as the device is in ON mode. When the peripheral is disabled, the pins will behave as regular GPIOs, and use the configuration in their respective OUT bit field and PIN_CNF[n] register. PSEL.SCL and PSEL.SDA must only be configured when the TWI slave is disabled.

To secure correct signal levels on the pins used by the TWI slave when the system is in OFF mode, and when the TWI slave is disabled, these pins must be configured in the GPIO peripheral as described in [GPIO configuration before enabling peripheral](#) on page 341.

Only one peripheral can be assigned to drive a particular GPIO pin at a time. Failing to do so may result in unpredictable behavior.

TWI slave signal	TWI slave pin	Direction	Output value	Drive strength
SCL	As specified in PSEL.SCL	Input	Not applicable	S0D1
SDA	As specified in PSEL.SDA	Input	Not applicable	S0D1

Table 102: GPIO configuration before enabling peripheral

6.26.8 Registers

Base address	Peripheral	Instance	Description	Configuration
0x40003000	TWIS	TWISO	Two-wire interface slave	

Table 103: Instances

Register	Offset	Description
TASKS_STOP	0x014	Stop TWI transaction
TASKS_SUSPEND	0x01C	Suspend TWI transaction
TASKS_RESUME	0x020	Resume TWI transaction
TASKS_PREPARERX	0x030	Prepare the TWI slave to respond to a write command
TASKS_PREPARETX	0x034	Prepare the TWI slave to respond to a read command
EVENTS_STOPPED	0x104	TWI stopped
EVENTS_ERROR	0x124	TWI error
EVENTS_RXSTARTED	0x14C	Receive sequence started
EVENTS_TXSTARTED	0x150	Transmit sequence started
EVENTS_WRITE	0x164	Write command received
EVENTS_READ	0x168	Read command received
SHORTS	0x200	Shortcuts between local events and tasks
INTEN	0x300	Enable or disable interrupt
INTENSET	0x304	Enable interrupt
INTENCLR	0x308	Disable interrupt
ERRORSRC	0x4D0	Error source
MATCH	0x4D4	Status register indicating which address had a match
ENABLE	0x500	Enable TWIS
PSEL.SCL	0x508	Pin select for SCL signal
PSEL.SDA	0x50C	Pin select for SDA signal
RXD.PTR	0x534	RXD Data pointer
RXD.MAXCNT	0x538	Maximum number of bytes in RXD buffer
RXD.AMOUNT	0x53C	Number of bytes transferred in the last RXD transaction
RXD.LIST	0x540	EasyDMA list type
TXD.PTR	0x544	TXD Data pointer
TXD.MAXCNT	0x548	Maximum number of bytes in TXD buffer
TXD.AMOUNT	0x54C	Number of bytes transferred in the last TXD transaction
TXD.LIST	0x550	EasyDMA list type
ADDRESS[0]	0x588	TWI slave address 0
ADDRESS[1]	0x58C	TWI slave address 1
CONFIG	0x594	Configuration register for the address match mechanism
ORC	0x5C0	Over-read character. Character sent out in case of an over-read of the transmit buffer.

Table 104: Register overview

6.26.8.1 TASKS_STOP

Address offset: 0x014

Stop TWI transaction

Bit number	31	30	29	28	27	26	25	24	23	22	21	20	19	18	17	16	15	14	13	12	11	10	9	8	7	6	5	4	3	2	1	0
ID																																A
Reset 0x00000000	0 0																															
ID	Acce Field	Value ID	Value	Description																												
A	W TASKS_STOP	Trigger	1	Stop TWI transaction Trigger task																												

6.26.8.2 TASKS_SUSPEND

Address offset: 0x01C

Suspend TWI transaction

Bit number	31	30	29	28	27	26	25	24	23	22	21	20	19	18	17	16	15	14	13	12	11	10	9	8	7	6	5	4	3	2	1	0
ID																																A
Reset 0x00000000	0 0																															
ID	Acce Field	Value ID	Value	Description																												
A	W TASKS_SUSPEND	Trigger	1	Suspend TWI transaction Trigger task																												

6.26.8.3 TASKS_RESUME

Address offset: 0x020

Resume TWI transaction

Bit number	31	30	29	28	27	26	25	24	23	22	21	20	19	18	17	16	15	14	13	12	11	10	9	8	7	6	5	4	3	2	1	0
ID																																A
Reset 0x00000000	0 0																															
ID	Acce Field	Value ID	Value	Description																												
A	W TASKS_RESUME	Trigger	1	Resume TWI transaction Trigger task																												

6.26.8.4 TASKS_PREPARERX

Address offset: 0x030

Prepare the TWI slave to respond to a write command

Bit number	31	30	29	28	27	26	25	24	23	22	21	20	19	18	17	16	15	14	13	12	11	10	9	8	7	6	5	4	3	2	1	0
ID																																A
Reset 0x00000000	0 0																															
ID	Acce Field	Value ID	Value	Description																												
A	W TASKS_PREPARERX	Trigger	1	Prepare the TWI slave to respond to a write command Trigger task																												

6.26.8.5 TASKS_PREPARETX

Address offset: 0x034

Prepare the TWI slave to respond to a read command

Bit number	31	30	29	28	27	26	25	24	23	22	21	20	19	18	17	16	15	14	13	12	11	10	9	8	7	6	5	4	3	2	1	0
ID																																A
Reset 0x00000000	0 0																															
ID	Acce Field	Value ID	Value	Description																												
A	W TASKS_PREPARETX	Trigger	1	Prepare the TWI slave to respond to a read command Trigger task																												

6.26.8.6 EVENTS_STOPPED

Address offset: 0x104

TWI stopped

Bit number	31	30	29	28	27	26	25	24	23	22	21	20	19	18	17	16	15	14	13	12	11	10	9	8	7	6	5	4	3	2	1	0
ID																																A
Reset 0x00000000	0 0																															
ID	Acce Field	Value ID	Value	Description																												
A	RW EVENTS_STOPPED	NotGenerated	0	Event not generated																												
		Generated	1	Event generated																												

6.26.8.7 EVENTS_ERROR

Address offset: 0x124

TWI error

Bit number	31	30	29	28	27	26	25	24	23	22	21	20	19	18	17	16	15	14	13	12	11	10	9	8	7	6	5	4	3	2	1	0
ID																																A
Reset 0x00000000	0 0																															
ID	Acce Field	Value ID	Value	Description																												
A	RW EVENTS_ERROR	NotGenerated	0	Event not generated																												
		Generated	1	Event generated																												

6.26.8.8 EVENTS_RXSTARTED

Address offset: 0x14C

Receive sequence started

Bit number	31	30	29	28	27	26	25	24	23	22	21	20	19	18	17	16	15	14	13	12	11	10	9	8	7	6	5	4	3	2	1	0
ID																																A
Reset 0x00000000	0 0																															
ID	Acce Field	Value ID	Value	Description																												
A	RW EVENTS_RXSTARTED	NotGenerated	0	Event not generated																												
		Generated	1	Event generated																												

6.26.8.9 EVENTS_TXSTARTED

Address offset: 0x150

Transmit sequence started

Bit number	31	30	29	28	27	26	25	24	23	22	21	20	19	18	17	16	15	14	13	12	11	10	9	8	7	6	5	4	3	2	1	0
ID																																A
Reset	0x00000000																															
	0 0																															
ID	Acce Field	Value ID	Value	Description																												
A	RW	EVENTS_TXSTARTED		Transmit sequence started																												
			NotGenerated	0	Event not generated																											
			Generated	1	Event generated																											

6.26.8.10 EVENTS_WRITE

Address offset: 0x164

Write command received

Bit number	31	30	29	28	27	26	25	24	23	22	21	20	19	18	17	16	15	14	13	12	11	10	9	8	7	6	5	4	3	2	1	0
ID																																A
Reset	0x00000000																															
	0 0																															
ID	Acce Field	Value ID	Value	Description																												
A	RW	EVENTS_WRITE		Write command received																												
			NotGenerated	0	Event not generated																											
			Generated	1	Event generated																											

6.26.8.11 EVENTS_READ

Address offset: 0x168

Read command received

Bit number	31	30	29	28	27	26	25	24	23	22	21	20	19	18	17	16	15	14	13	12	11	10	9	8	7	6	5	4	3	2	1	0
ID																																A
Reset	0x00000000																															
	0 0																															
ID	Acce Field	Value ID	Value	Description																												
A	RW	EVENTS_READ		Read command received																												
			NotGenerated	0	Event not generated																											
			Generated	1	Event generated																											

6.26.8.12 SHORTS

Address offset: 0x200

Shortcuts between local events and tasks

Bit number	31	30	29	28	27	26	25	24	23	22	21	20	19	18	17	16	15	14	13	12	11	10	9	8	7	6	5	4	3	2	1	0
ID																													B	A		
Reset	0x00000000																															
	0 0																															
ID	Acce Field	Value ID	Value	Description																												
A	RW	WRITE_SUSPEND		Shortcut between event WRITE and task SUSPEND																												
			Disabled	0	Disable shortcut																											
			Enabled	1	Enable shortcut																											
B	RW	READ_SUSPEND		Shortcut between event READ and task SUSPEND																												
			Disabled	0	Disable shortcut																											
			Enabled	1	Enable shortcut																											

6.26.8.13 INTEN

Address offset: 0x300

Enable or disable interrupt

Bit number	31 30 29 28 27 26 25 24 23 22 21 20 19 18 17 16 15 14 13 12 11 10 9 8 7 6 5 4 3 2 1 0																														
ID											H G		F E		B						A										
Reset 0x00000000	0 0																														
ID	Acce	Field	Value	ID	Value	Description																									
A	RW	STOPPED			Enable or disable interrupt for event STOPPED																										
			Disabled	0	Disable																										
			Enabled	1	Enable																										
B	RW	ERROR			Enable or disable interrupt for event ERROR																										
			Disabled	0	Disable																										
			Enabled	1	Enable																										
E	RW	RXSTARTED			Enable or disable interrupt for event RXSTARTED																										
			Disabled	0	Disable																										
			Enabled	1	Enable																										
F	RW	TXSTARTED			Enable or disable interrupt for event TXSTARTED																										
			Disabled	0	Disable																										
			Enabled	1	Enable																										
G	RW	WRITE			Enable or disable interrupt for event WRITE																										
			Disabled	0	Disable																										
			Enabled	1	Enable																										
H	RW	READ			Enable or disable interrupt for event READ																										
			Disabled	0	Disable																										
			Enabled	1	Enable																										

6.26.8.14 INTENSET

Address offset: 0x304

Enable interrupt

Bit number	31 30 29 28 27 26 25 24 23 22 21 20 19 18 17 16 15 14 13 12 11 10 9 8 7 6 5 4 3 2 1 0																														
ID											H G		F E		B						A										
Reset 0x00000000	0 0																														
ID	Acce	Field	Value	ID	Value	Description																									
A	RW	STOPPED			Write '1' to enable interrupt for event STOPPED																										
			Set	1	Enable																										
			Disabled	0	Read: Disabled																										
			Enabled	1	Read: Enabled																										
B	RW	ERROR			Write '1' to enable interrupt for event ERROR																										
			Set	1	Enable																										
			Disabled	0	Read: Disabled																										
			Enabled	1	Read: Enabled																										
E	RW	RXSTARTED			Write '1' to enable interrupt for event RXSTARTED																										
			Set	1	Enable																										
			Disabled	0	Read: Disabled																										
			Enabled	1	Read: Enabled																										
F	RW	TXSTARTED			Write '1' to enable interrupt for event TXSTARTED																										
			Set	1	Enable																										
			Disabled	0	Read: Disabled																										
			Enabled	1	Read: Enabled																										

Bit number	31 30 29 28 27 26 25 24 23 22 21 20 19 18 17 16 15 14 13 12 11 10 9 8 7 6 5 4 3 2 1 0																														
ID	H G										F E										B										A
Reset 0x00000000	0 0																														
ID	Acce Field	Value ID	Value	Description																											
G	RW WRITE			Write '1' to enable interrupt for event WRITE																											
		Set	1	Enable																											
		Disabled	0	Read: Disabled																											
		Enabled	1	Read: Enabled																											
H	RW READ			Write '1' to enable interrupt for event READ																											
		Set	1	Enable																											
		Disabled	0	Read: Disabled																											
		Enabled	1	Read: Enabled																											

6.26.8.15 INTENCLR

Address offset: 0x308

Disable interrupt

Bit number	31 30 29 28 27 26 25 24 23 22 21 20 19 18 17 16 15 14 13 12 11 10 9 8 7 6 5 4 3 2 1 0																														
ID	H G										F E										B										A
Reset 0x00000000	0 0																														
ID	Acce Field	Value ID	Value	Description																											
A	RW STOPPED			Write '1' to disable interrupt for event STOPPED																											
		Clear	1	Disable																											
		Disabled	0	Read: Disabled																											
		Enabled	1	Read: Enabled																											
B	RW ERROR			Write '1' to disable interrupt for event ERROR																											
		Clear	1	Disable																											
		Disabled	0	Read: Disabled																											
		Enabled	1	Read: Enabled																											
E	RW RXSTARTED			Write '1' to disable interrupt for event RXSTARTED																											
		Clear	1	Disable																											
		Disabled	0	Read: Disabled																											
		Enabled	1	Read: Enabled																											
F	RW TXSTARTED			Write '1' to disable interrupt for event TXSTARTED																											
		Clear	1	Disable																											
		Disabled	0	Read: Disabled																											
		Enabled	1	Read: Enabled																											
G	RW WRITE			Write '1' to disable interrupt for event WRITE																											
		Clear	1	Disable																											
		Disabled	0	Read: Disabled																											
		Enabled	1	Read: Enabled																											
H	RW READ			Write '1' to disable interrupt for event READ																											
		Clear	1	Disable																											
		Disabled	0	Read: Disabled																											
		Enabled	1	Read: Enabled																											

6.26.8.16 ERRORSRC

Address offset: 0x4D0

Error source

Bit number	31 30 29 28 27 26 25 24 23 22 21 20 19 18 17 16 15 14 13 12 11 10 9 8 7 6 5 4 3 2 1 0																																
ID																															C	B	A
Reset 0x00000000	0 0																																
ID	Acce Field	Value ID	Value	Description																													
A	RW OVERFLOW			RX buffer overflow detected, and prevented																													
		NotDetected	0	Error did not occur																													
		Detected	1	Error occurred																													
B	RW DNACK			NACK sent after receiving a data byte																													
		NotReceived	0	Error did not occur																													
		Received	1	Error occurred																													
C	RW OVERREAD			TX buffer over-read detected, and prevented																													
		NotDetected	0	Error did not occur																													
		Detected	1	Error occurred																													

6.26.8.17 MATCH

Address offset: 0x4D4

Status register indicating which address had a match

Bit number	31 30 29 28 27 26 25 24 23 22 21 20 19 18 17 16 15 14 13 12 11 10 9 8 7 6 5 4 3 2 1 0																														
ID																															A
Reset 0x00000000	0 0																														
ID	Acce Field	Value ID	Value	Description																											
A	R MATCH		[0..1]	Which of the addresses in {ADDRESS} matched the incoming address																											

6.26.8.18 ENABLE

Address offset: 0x500

Enable TWIS

Bit number	31 30 29 28 27 26 25 24 23 22 21 20 19 18 17 16 15 14 13 12 11 10 9 8 7 6 5 4 3 2 1 0																																	
ID																															A	A	A	A
Reset 0x00000000	0 0																																	
ID	Acce Field	Value ID	Value	Description																														
A	RW ENABLE			Enable or disable TWIS																														
		Disabled	0	Disable TWIS																														
		Enabled	9	Enable TWIS																														

6.26.8.19 PSEL.SCL

Address offset: 0x508

Pin select for SCL signal

Bit number	31 30 29 28 27 26 25 24 23 22 21 20 19 18 17 16 15 14 13 12 11 10 9 8 7 6 5 4 3 2 1 0																																		
ID	C																														A	A	A	A	A
Reset 0xFFFFFFFF	1 1																																		
ID	Acce Field	Value ID	Value	Description																															
A	RW PIN		[0..31]	Pin number																															
C	RW CONNECT			Connection																															
		Disconnected	1	Disconnect																															
		Connected	0	Connect																															

6.26.8.20 PSEL.SDA

Address offset: 0x50C

Pin select for SDA signal

Bit number	31	30	29	28	27	26	25	24	23	22	21	20	19	18	17	16	15	14	13	12	11	10	9	8	7	6	5	4	3	2	1	0
ID	C																A A A A A															
Reset 0xFFFFFFFF	1 1																															
ID	Access	Field	Value ID	Value	Description																											
A	RW	PIN		[0..31]	Pin number																											
C	RW	CONNECT	Disconnected	1	Disconnect																											
			Connected	0	Connect																											

6.26.8.21 RXD.PTR

Address offset: 0x534

RXD Data pointer

Bit number	31	30	29	28	27	26	25	24	23	22	21	20	19	18	17	16	15	14	13	12	11	10	9	8	7	6	5	4	3	2	1	0
ID	A A																															
Reset 0x00000000	0 0																															
ID	Access	Field	Value ID	Value	Description																											
A	RW	PTR			RXD Data pointer																											

Note: See the memory chapter for details about which memories are available for EasyDMA.

6.26.8.22 RXD.MAXCNT

Address offset: 0x538

Maximum number of bytes in RXD buffer

Bit number	31	30	29	28	27	26	25	24	23	22	21	20	19	18	17	16	15	14	13	12	11	10	9	8	7	6	5	4	3	2	1	0
ID																	A A A A A A A A A A															
Reset 0x00000000	0 0																															
ID	Access	Field	Value ID	Value	Description																											
A	RW	MAXCNT		[1..0x3FF]	Maximum number of bytes in RXD buffer																											

6.26.8.23 RXD.AMOUNT

Address offset: 0x53C

Number of bytes transferred in the last RXD transaction

Bit number	31	30	29	28	27	26	25	24	23	22	21	20	19	18	17	16	15	14	13	12	11	10	9	8	7	6	5	4	3	2	1	0
ID																	A A A A A A A A A A															
Reset 0x00000000	0 0																															
ID	Access	Field	Value ID	Value	Description																											
A	R	AMOUNT		[1..0x3FF]	Number of bytes transferred in the last RXD transaction																											

6.26.8.24 RXD.LIST

Address offset: 0x540

EasyDMA list type

Bit number	31 30 29 28 27 26 25 24 23 22 21 20 19 18 17 16 15 14 13 12 11 10 9 8 7 6 5 4 3 2 1 0																														
ID	A A																														
Reset 0x00000000	0 0																														
ID	Acce Field	Value ID	Value	Description																											
A	RW LIST			List type																											
		Disabled	0	Disable EasyDMA list																											
		ArrayList	1	Use array list																											

6.26.8.25 TXD.PTR

Address offset: 0x544

TXD Data pointer

Bit number	31 30 29 28 27 26 25 24 23 22 21 20 19 18 17 16 15 14 13 12 11 10 9 8 7 6 5 4 3 2 1 0																														
ID	A A																														
Reset 0x00000000	0 0																														
ID	Acce Field	Value ID	Value	Description																											
A	RW PTR			TXD Data pointer																											

Note: See the memory chapter for details about which memories are available for EasyDMA.

6.26.8.26 TXD.MAXCNT

Address offset: 0x548

Maximum number of bytes in TXD buffer

Bit number	31 30 29 28 27 26 25 24 23 22 21 20 19 18 17 16 15 14 13 12 11 10 9 8 7 6 5 4 3 2 1 0																														
ID	A A																														
Reset 0x00000000	0 0																														
ID	Acce Field	Value ID	Value	Description																											
A	RW MAXCNT		[1..0x3FF]	Maximum number of bytes in TXD buffer																											

6.26.8.27 TXD.AMOUNT

Address offset: 0x54C

Number of bytes transferred in the last TXD transaction

Bit number	31 30 29 28 27 26 25 24 23 22 21 20 19 18 17 16 15 14 13 12 11 10 9 8 7 6 5 4 3 2 1 0																														
ID	A A																														
Reset 0x00000000	0 0																														
ID	Acce Field	Value ID	Value	Description																											
A	R AMOUNT		[1..0x3FF]	Number of bytes transferred in the last TXD transaction																											

6.26.8.28 TXD.LIST

Address offset: 0x550

EasyDMA list type

Bit number	31 30 29 28 27 26 25 24 23 22 21 20 19 18 17 16 15 14 13 12 11 10 9 8 7 6 5 4 3 2 1 0																															
ID																															A	A
Reset 0x00000000	0 0																															
ID	Acce Field	Value ID	Value	Description																												
A	RW LIST			List type																												
		Disabled	0	Disable EasyDMA list																												
		ArrayList	1	Use array list																												

6.26.8.29 ADDRESS[n] (n=0..1)

Address offset: 0x588 + (n × 0x4)

TWI slave address n

Bit number	31 30 29 28 27 26 25 24 23 22 21 20 19 18 17 16 15 14 13 12 11 10 9 8 7 6 5 4 3 2 1 0																																			
ID																															A	A	A	A	A	A
Reset 0x00000000	0 0																																			
ID	Acce Field	Value ID	Value	Description																																
A	RW ADDRESS			TWI slave address																																

6.26.8.30 CONFIG

Address offset: 0x594

Configuration register for the address match mechanism

Bit number	31 30 29 28 27 26 25 24 23 22 21 20 19 18 17 16 15 14 13 12 11 10 9 8 7 6 5 4 3 2 1 0																															
ID																															B	A
Reset 0x00000001	0 1																															
ID	Acce Field	Value ID	Value	Description																												
A-B	RW ADDRESS[i] (i=0..1)			Enable or disable address matching on ADDRESS[i]																												
		Disabled	0	Disabled																												
		Enabled	1	Enabled																												

6.26.8.31 ORC

Address offset: 0x5C0

Over-read character. Character sent out in case of an over-read of the transmit buffer.

Bit number	31 30 29 28 27 26 25 24 23 22 21 20 19 18 17 16 15 14 13 12 11 10 9 8 7 6 5 4 3 2 1 0																																				
ID																															A	A	A	A	A	A	A
Reset 0x00000000	0 0																																				
ID	Acce Field	Value ID	Value	Description																																	
A	RW ORC			Over-read character. Character sent out in case of an over-read of the transmit buffer.																																	

6.26.9 Electrical specification

6.26.9.1 TWIS slave timing specifications

Symbol	Description	Min.	Typ.	Max.	Units
$f_{TWIS,SCL}$	Bit rates for TWIS ³¹	100		400	kbps
$t_{TWIS,START}$	Time from PREPARERX/PREPARETX task to ready to receive/transmit		1.5		μ s
t_{TWIS,SU_DAT}	Data setup time before positive edge on SCL – all modes	300			ns
t_{TWIS,HD_DAT}	Data hold time after negative edge on SCL – all modes	500			ns
$t_{TWIS,HD_STA,100kbps}$	TWI slave hold time from for START condition (SDA low to SCL low), 100 kbps	5200			ns
$t_{TWIS,HD_STA,400kbps}$	TWI slave hold time from for START condition (SDA low to SCL low), 400 kbps	1300			ns
$t_{TWIS,SU_STO,100kbps}$	TWI slave setup time from SCL high to STOP condition, 100 kbps	5200			ns
$t_{TWIS,SU_STO,400kbps}$	TWI slave setup time from SCL high to STOP condition, 400 kbps	1300			ns
$t_{TWIS,BUF,100kbps}$	TWI slave bus free time between STOP and START conditions, 100 kbps		4700		ns
$t_{TWIS,BUF,400kbps}$	TWI slave bus free time between STOP and START conditions, 400 kbps		1300		ns

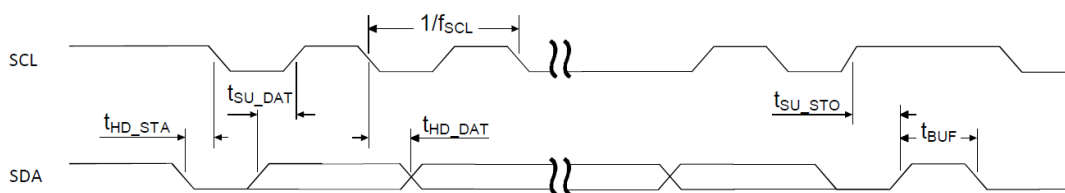

Figure 129: TWIS timing diagram, 1 byte transaction

6.27 UART — Universal asynchronous receiver/transmitter

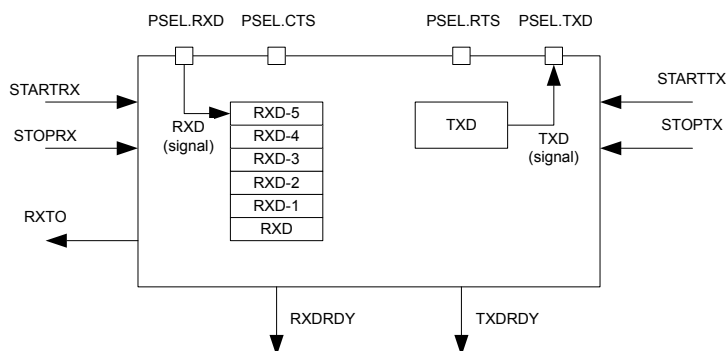

Figure 130: UART configuration

³¹ High bit rates or stronger pull-ups may require GPIOs to be set as High Drive, see GPIO chapter for more details.

6.27.1 Functional description

Listed here are the main features of UART.

The UART implements support for the following features:

- Full-duplex operation
- Automatic flow control
- Parity checking and generation for the 9th data bit

As illustrated in [UART configuration](#) on page 351, the UART uses the TXD and RXD registers directly to transmit and receive data. The UART uses one stop bit.

Note: External crystal oscillator must be enabled to obtain sufficient clock accuracy for stable communication. See [CLOCK — Clock control](#) on page 62 for more information.

6.27.2 Pin configuration

The different signals RXD, CTS (Clear To Send, active low), RTS (Request To Send, active low), and TXD associated with the UART are mapped to physical pins according to the configuration specified in the PSEL.RXD, PSEL.CTS, PSEL.RTS, and PSEL.TXD registers respectively.

If the CONNECT field of a PSEL.xxx register is set to Disconnected, the associated UART signal will not be connected to any physical pin. The PSEL.RXD, PSEL.CTS, PSEL.RTS, and PSEL.TXD registers and their configurations are only used as long as the UART is enabled, and retained only for the duration the device is in ON mode. PSEL.RXD, PSEL.CTS, PSEL.RTS and PSEL.TXD must only be configured when the UART is disabled.

To secure correct signal levels on the pins by the UART when the system is in OFF mode, the pins must be configured in the GPIO peripheral as described in [Pin configuration](#) on page 352.

Only one peripheral can be assigned to drive a particular GPIO pin at a time. Failing to do so may result in unpredictable behavior.

UART pin	Direction	Output value
RXD	Input	Not applicable
CTS	Input	Not applicable
RTS	Output	1
TXD	Output	1

Table 105: GPIO configuration

6.27.3 Shared resources

The UART shares registers and other resources with other peripherals that have the same ID as the UART.

Therefore, you must disable all peripherals that have the same ID as the UART before the UART can be configured and used. Disabling a peripheral that has the same ID as the UART will not reset any of the registers that are shared with the UART. It is therefore important to configure all relevant UART registers explicitly to ensure that it operates correctly.

See the Instantiation table in [Instantiation](#) on page 19 for details on peripherals and their IDs.

6.27.4 Transmission

A UART transmission sequence is started by triggering the STARTTX task.

Bytes are transmitted by writing to the TXD register. When a byte has been successfully transmitted the UART will generate a TXDRDY event after which a new byte can be written to the TXD register. A UART transmission sequence is stopped immediately by triggering the STOPTH task.

If flow control is enabled a transmission will be automatically suspended when CTS is deactivated and resumed when CTS is activated again, as illustrated in [UART transmission](#) on page 353. A byte that is in transmission when CTS is deactivated will be fully transmitted before the transmission is suspended. For more information, see [Suspending the UART](#) on page 354.

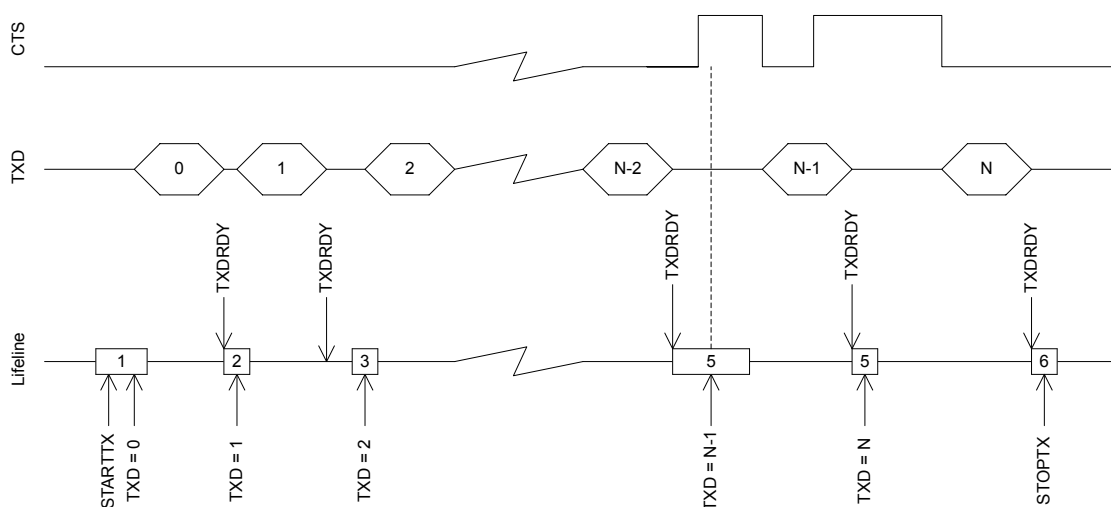

Figure 131: UART transmission

6.27.5 Reception

A UART reception sequence is started by triggering the STARTRX task.

The UART receiver chain implements a FIFO capable of storing six incoming RXD bytes before data is overwritten. Bytes are extracted from this FIFO by reading the RXD register. When a byte is extracted from the FIFO a new byte pending in the FIFO will be moved to the RXD register. The UART will generate an RXDRDY event every time a new byte is moved to the RXD register.

When flow control is enabled, the UART will deactivate the RTS signal when there is only space for four more bytes in the receiver FIFO. The counterpart transmitter is therefore able to send up to four bytes after the RTS signal is deactivated before data is being overwritten. To prevent overwriting data in the FIFO, the counterpart UART transmitter must therefore make sure to stop transmitting data within four bytes after the RTS line is deactivated.

The RTS signal will first be activated again when the FIFO has been emptied, that is, when all bytes in the FIFO have been read by the CPU, see [UART reception](#) on page 354.

The RTS signal will also be deactivated when the receiver is stopped through the STOPRX task as illustrated in [UART reception](#) on page 354. The UART is able to receive four to five additional bytes if they are sent in succession immediately after the RTS signal has been deactivated. This is possible because the UART is, even after the STOPRX task is triggered, able to receive bytes for an extended period of time dependent on the configured baud rate. The UART will generate a receiver timeout event (RXTO) when this period has elapsed.

To prevent loss of incoming data the RXD register must only be read one time following every RXDRDY event.

To secure that the CPU can detect all incoming RXDRDY events through the RXDRDY event register, the RXDRDY event register must be cleared before the RXD register is read. The reason for this is that the UART is allowed to write a new byte to the RXD register, and therefore can also generate a new event, immediately after the RXD register is read (emptied) by the CPU.

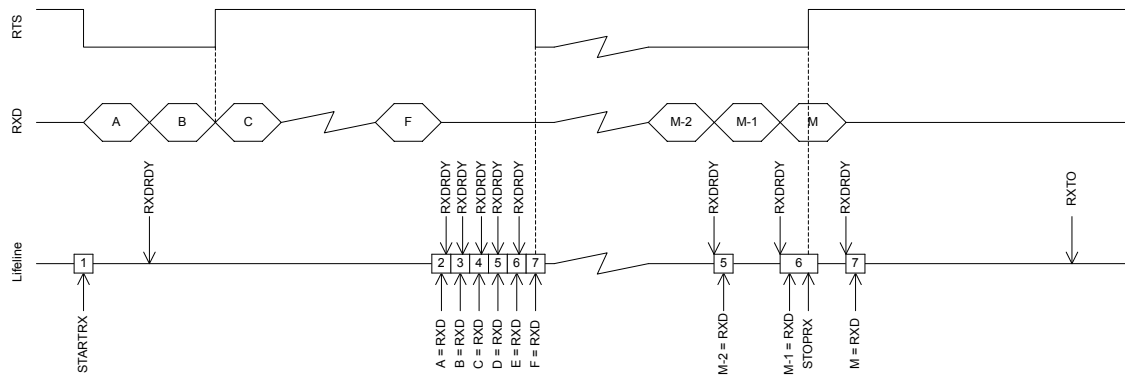

Figure 132: UART reception

As indicated in occurrence 2 in the figure, the RXDRDY event associated with byte B is generated first after byte A has been extracted from RXD.

6.27.6 Suspending the UART

The UART can be suspended by triggering the SUSPEND task.

SUSPEND will affect both the UART receiver and the UART transmitter, i.e. the transmitter will stop transmitting and the receiver will stop receiving. UART transmission and reception can be resumed, after being suspended, by triggering STARTTX and STARTRX respectively.

Following a SUSPEND task, an ongoing TXD byte transmission will be completed before the UART is suspended.

When the SUSPEND task is triggered, the UART receiver will behave in the same way as it does when the STOPRX task is triggered.

6.27.7 Error conditions

An ERROR event, in the form of a framing error, will be generated if a valid stop bit is not detected in a frame. Another ERROR event, in the form of a break condition, will be generated if the RXD line is held active low for longer than the length of a data frame. Effectively, a framing error is always generated before a break condition occurs.

6.27.8 Using the UART without flow control

If flow control is not enabled, the interface will behave as if the CTS and RTS lines are kept active all the time.

6.27.9 Parity and stop bit configuration

Automatic even parity generation for both transmission and reception can be configured using the register CONFIG on page 363. See the register description for details.

The amount of stop bits can also be configured through the register CONFIG on page 363.

6.27.10 Registers

Base address	Peripheral	Instance	Description	Configuration
0x40002000	UART	UART0	Universal asynchronous receiver/transmitter	Deprecated

Table 106: Instances

Register	Offset	Description
TASKS_STARTRX	0x000	Start UART receiver
TASKS_STOPRX	0x004	Stop UART receiver
TASKS_STARTTX	0x008	Start UART transmitter
TASKS_STOPTX	0x00C	Stop UART transmitter
TASKS_SUSPEND	0x01C	Suspend UART
EVENTS_CTS	0x100	CTS is activated (set low). Clear To Send.
EVENTS_NCTS	0x104	CTS is deactivated (set high). Not Clear To Send.
EVENTS_RXDRDY	0x108	Data received in RXD
EVENTS_TXDRDY	0x11C	Data sent from TXD
EVENTS_ERROR	0x124	Error detected
EVENTS_RXTO	0x144	Receiver timeout
SHORTS	0x200	Shortcuts between local events and tasks
INTENSET	0x304	Enable interrupt
INTENCLR	0x308	Disable interrupt
ERRORSRC	0x480	Error source
ENABLE	0x500	Enable UART
PSEL.RTS	0x508	Pin select for RTS
PSEL.TXD	0x50C	Pin select for TXD
PSEL.CTS	0x510	Pin select for CTS
PSEL.RXD	0x514	Pin select for RXD
RXD	0x518	RXD register
TXD	0x51C	TXD register
BAUDRATE	0x524	Baud rate. Accuracy depends on the HFCLK source selected.
CONFIG	0x56C	Configuration of parity and hardware flow control

Table 107: Register overview

6.27.10.1 TASKS_STARTRX

Address offset: 0x000

Start UART receiver

Bit number	31 30 29 28 27 26 25 24 23 22 21 20 19 18 17 16 15 14 13 12 11 10 9 8 7 6 5 4 3 2 1 0																														
ID	A																														
Reset 0x00000000	0 0																														
ID	Acce	Field	Value	ID	Value	Description																									
A	W	TASKS_STARTRX				Start UART receiver																									
			Trigger		1	Trigger task																									

6.27.10.2 TASKS_STOPRX

Address offset: 0x004

Stop UART receiver

Bit number	31 30 29 28 27 26 25 24 23 22 21 20 19 18 17 16 15 14 13 12 11 10 9 8 7 6 5 4 3 2 1 0																														
ID	A																														
Reset 0x00000000	0 0																														
ID	Acce	Field	Value	ID	Value	Description																									
A	W	TASKS_STOPRX				Stop UART receiver																									
			Trigger		1	Trigger task																									

6.27.10.3 TASKS_STARTTX

Address offset: 0x008

Start UART transmitter

Bit number	31 30 29 28 27 26 25 24 23 22 21 20 19 18 17 16 15 14 13 12 11 10 9 8 7 6 5 4 3 2 1 0																														
ID	A																														
Reset 0x00000000	0 0																														
ID	Acce Field	Value ID	Value	Description																											
A	W TASKS_STARTTX			Start UART transmitter																											
		Trigger	1	Trigger task																											

6.27.10.4 TASKS_STOPTX

Address offset: 0x00C

Stop UART transmitter

Bit number	31 30 29 28 27 26 25 24 23 22 21 20 19 18 17 16 15 14 13 12 11 10 9 8 7 6 5 4 3 2 1 0																														
ID	A																														
Reset 0x00000000	0 0																														
ID	Acce Field	Value ID	Value	Description																											
A	W TASKS_STOPTX			Stop UART transmitter																											
		Trigger	1	Trigger task																											

6.27.10.5 TASKS_SUSPEND

Address offset: 0x01C

Suspend UART

Bit number	31 30 29 28 27 26 25 24 23 22 21 20 19 18 17 16 15 14 13 12 11 10 9 8 7 6 5 4 3 2 1 0																														
ID	A																														
Reset 0x00000000	0 0																														
ID	Acce Field	Value ID	Value	Description																											
A	W TASKS_SUSPEND			Suspend UART																											
		Trigger	1	Trigger task																											

6.27.10.6 EVENTS_CTS

Address offset: 0x100

CTS is activated (set low). Clear To Send.

Bit number	31 30 29 28 27 26 25 24 23 22 21 20 19 18 17 16 15 14 13 12 11 10 9 8 7 6 5 4 3 2 1 0																														
ID	A																														
Reset 0x00000000	0 0																														
ID	Acce Field	Value ID	Value	Description																											
A	RW EVENTS_CTS			CTS is activated (set low). Clear To Send.																											
		NotGenerated	0	Event not generated																											
		Generated	1	Event generated																											

6.27.10.7 EVENTS_NCTS

Address offset: 0x104

CTS is deactivated (set high). Not Clear To Send.

Bit number	31 30 29 28 27 26 25 24 23 22 21 20 19 18 17 16 15 14 13 12 11 10 9 8 7 6 5 4 3 2 1 0																														
ID	A																														
Reset 0x00000000	0 0																														
ID	Acce Field	Value ID	Value	Description																											
A	RW	EVENTS_NCTS		CTS is deactivated (set high). Not Clear To Send.																											
		NotGenerated	0	Event not generated																											
		Generated	1	Event generated																											

6.27.10.8 EVENTS_RXDRDY

Address offset: 0x108

Data received in RXD

Bit number	31 30 29 28 27 26 25 24 23 22 21 20 19 18 17 16 15 14 13 12 11 10 9 8 7 6 5 4 3 2 1 0																														
ID	A																														
Reset 0x00000000	0 0																														
ID	Acce Field	Value ID	Value	Description																											
A	RW	EVENTS_RXDRDY		Data received in RXD																											
		NotGenerated	0	Event not generated																											
		Generated	1	Event generated																											

6.27.10.9 EVENTS_TXDRDY

Address offset: 0x11C

Data sent from TXD

Bit number	31 30 29 28 27 26 25 24 23 22 21 20 19 18 17 16 15 14 13 12 11 10 9 8 7 6 5 4 3 2 1 0																														
ID	A																														
Reset 0x00000000	0 0																														
ID	Acce Field	Value ID	Value	Description																											
A	RW	EVENTS_TXDRDY		Data sent from TXD																											
		NotGenerated	0	Event not generated																											
		Generated	1	Event generated																											

6.27.10.10 EVENTS_ERROR

Address offset: 0x124

Error detected

Bit number	31 30 29 28 27 26 25 24 23 22 21 20 19 18 17 16 15 14 13 12 11 10 9 8 7 6 5 4 3 2 1 0																														
ID	A																														
Reset 0x00000000	0 0																														
ID	Acce Field	Value ID	Value	Description																											
A	RW	EVENTS_ERROR		Error detected																											
		NotGenerated	0	Event not generated																											
		Generated	1	Event generated																											

6.27.10.11 EVENTS_RXTO

Address offset: 0x144

Receiver timeout

Bit number	31	30	29	28	27	26	25	24	23	22	21	20	19	18	17	16	15	14	13	12	11	10	9	8	7	6	5	4	3	2	1	0
ID																																A
Reset 0x00000000	0 0																															
ID	Acce Field	Value ID	Value	Description																												
A	RW EVENTS_RXTO			Receiver timeout																												
		NotGenerated	0	Event not generated																												
		Generated	1	Event generated																												

6.27.10.12 SHORTS

Address offset: 0x200

Shortcuts between local events and tasks

Bit number	31	30	29	28	27	26	25	24	23	22	21	20	19	18	17	16	15	14	13	12	11	10	9	8	7	6	5	4	3	2	1	0
ID																																B A
Reset 0x00000000	0 0																															
ID	Acce Field	Value ID	Value	Description																												
A	RW CTS_STARTRX			Shortcut between event CTS and task STARTRX																												
		Disabled	0	Disable shortcut																												
		Enabled	1	Enable shortcut																												
B	RW NCTS_STOPRX			Shortcut between event NCTS and task STOPRX																												
		Disabled	0	Disable shortcut																												
		Enabled	1	Enable shortcut																												

6.27.10.13 INTENSET

Address offset: 0x304

Enable interrupt

Bit number	31	30	29	28	27	26	25	24	23	22	21	20	19	18	17	16	15	14	13	12	11	10	9	8	7	6	5	4	3	2	1	0
ID																																F E D C B A
Reset 0x00000000	0 0																															
ID	Acce Field	Value ID	Value	Description																												
A	RW CTS			Write '1' to enable interrupt for event CTS																												
		Set	1	Enable																												
		Disabled	0	Read: Disabled																												
		Enabled	1	Read: Enabled																												
B	RW NCTS			Write '1' to enable interrupt for event NCTS																												
		Set	1	Enable																												
		Disabled	0	Read: Disabled																												
		Enabled	1	Read: Enabled																												
C	RW RXDRDY			Write '1' to enable interrupt for event RXDRDY																												
		Set	1	Enable																												
		Disabled	0	Read: Disabled																												
		Enabled	1	Read: Enabled																												
D	RW TXDRDY			Write '1' to enable interrupt for event TXDRDY																												
		Set	1	Enable																												

Bit number	31 30 29 28 27 26 25 24 23 22 21 20 19 18 17 16 15 14 13 12 11 10 9 8 7 6 5 4 3 2 1 0																														
ID	F															E					D	C				B	A				
Reset 0x00000000	0 0																														
ID	Acce	Field	Value	ID	Value	Description																									
			Disabled		0	Read: Disabled																									
			Enabled		1	Read: Enabled																									
E	RW	ERROR				Write '1' to enable interrupt for event ERROR																									
			Set		1	Enable																									
			Disabled		0	Read: Disabled																									
			Enabled		1	Read: Enabled																									
F	RW	RXTO				Write '1' to enable interrupt for event RXTO																									
			Set		1	Enable																									
			Disabled		0	Read: Disabled																									
			Enabled		1	Read: Enabled																									

6.27.10.14 INTENCLR

Address offset: 0x308

Disable interrupt

Bit number	31 30 29 28 27 26 25 24 23 22 21 20 19 18 17 16 15 14 13 12 11 10 9 8 7 6 5 4 3 2 1 0																														
ID	F															E					D	C				B	A				
Reset 0x00000000	0 0																														
ID	Acce	Field	Value	ID	Value	Description																									
A	RW	CTS				Write '1' to disable interrupt for event CTS																									
			Clear		1	Disable																									
			Disabled		0	Read: Disabled																									
			Enabled		1	Read: Enabled																									
B	RW	NCTS				Write '1' to disable interrupt for event NCTS																									
			Clear		1	Disable																									
			Disabled		0	Read: Disabled																									
			Enabled		1	Read: Enabled																									
C	RW	RXDRDY				Write '1' to disable interrupt for event RXDRDY																									
			Clear		1	Disable																									
			Disabled		0	Read: Disabled																									
			Enabled		1	Read: Enabled																									
D	RW	TXDRDY				Write '1' to disable interrupt for event TXDRDY																									
			Clear		1	Disable																									
			Disabled		0	Read: Disabled																									
			Enabled		1	Read: Enabled																									
E	RW	ERROR				Write '1' to disable interrupt for event ERROR																									
			Clear		1	Disable																									
			Disabled		0	Read: Disabled																									
			Enabled		1	Read: Enabled																									
F	RW	RXTO				Write '1' to disable interrupt for event RXTO																									
			Clear		1	Disable																									
			Disabled		0	Read: Disabled																									
			Enabled		1	Read: Enabled																									

6.27.10.15 ERRORSRC

Address offset: 0x480

Error source

Bit number	31 30 29 28 27 26 25 24 23 22 21 20 19 18 17 16 15 14 13 12 11 10 9 8 7 6 5 4 3 2 1 0																														
ID	D C B A																														
Reset	0x00000000																														
Reset	0 0																														
ID	Acce	Field	Value ID	Value	Description																										
A	RW	OVERRUN			Overrun error																										
					A start bit is received while the previous data still lies in RXD. (Previous data is lost.)																										
			NotPresent	0	Read: error not present																										
			Present	1	Read: error present																										
B	RW	PARITY			Parity error																										
					A character with bad parity is received, if HW parity check is enabled.																										
			NotPresent	0	Read: error not present																										
			Present	1	Read: error present																										
C	RW	FRAMING			Framing error occurred																										
					A valid stop bit is not detected on the serial data input after all bits in a character have been received.																										
			NotPresent	0	Read: error not present																										
			Present	1	Read: error present																										
D	RW	BREAK			Break condition																										
					The serial data input is '0' for longer than the length of a data frame. (The data frame length is 10 bits without parity bit, and 11 bits with parity bit.)																										
			NotPresent	0	Read: error not present																										
			Present	1	Read: error present																										

6.27.10.16 ENABLE

Address offset: 0x500

Enable UART

Bit number	31 30 29 28 27 26 25 24 23 22 21 20 19 18 17 16 15 14 13 12 11 10 9 8 7 6 5 4 3 2 1 0																														
ID	A A A A																														
Reset	0x00000000																														
Reset	0 0																														
ID	Acce	Field	Value ID	Value	Description																										
A	RW	ENABLE			Enable or disable UART																										
			Disabled	0	Disable UART																										
			Enabled	4	Enable UART																										

6.27.10.17 PSEL.RTS

Address offset: 0x508

Pin select for RTS

Bit number	31	30	29	28	27	26	25	24	23	22	21	20	19	18	17	16	15	14	13	12	11	10	9	8	7	6	5	4	3	2	1	0
ID	C																											A	A	A	A	A
Reset 0xFFFFFFFF	1	1	1	1	1	1	1	1	1	1	1	1	1	1	1	1	1	1	1	1	1	1	1	1	1	1	1	1	1	1	1	
ID	Acce	Field	Value ID	Value	Description																											
A	RW	PIN		[0..31]	Pin number																											
C	RW	CONNECT			Connection																											
			Disconnected	1	Disconnect																											
			Connected	0	Connect																											

6.27.10.18 PSEL.TXD

Address offset: 0x50C

Pin select for TXD

Bit number	31	30	29	28	27	26	25	24	23	22	21	20	19	18	17	16	15	14	13	12	11	10	9	8	7	6	5	4	3	2	1	0
ID	C																											A	A	A	A	A
Reset 0xFFFFFFFF	1	1	1	1	1	1	1	1	1	1	1	1	1	1	1	1	1	1	1	1	1	1	1	1	1	1	1	1	1	1	1	
ID	Acce	Field	Value ID	Value	Description																											
A	RW	PIN		[0..31]	Pin number																											
C	RW	CONNECT			Connection																											
			Disconnected	1	Disconnect																											
			Connected	0	Connect																											

6.27.10.19 PSEL.CTS

Address offset: 0x510

Pin select for CTS

Bit number	31	30	29	28	27	26	25	24	23	22	21	20	19	18	17	16	15	14	13	12	11	10	9	8	7	6	5	4	3	2	1	0
ID	C																											A	A	A	A	A
Reset 0xFFFFFFFF	1	1	1	1	1	1	1	1	1	1	1	1	1	1	1	1	1	1	1	1	1	1	1	1	1	1	1	1	1	1	1	
ID	Acce	Field	Value ID	Value	Description																											
A	RW	PIN		[0..31]	Pin number																											
C	RW	CONNECT			Connection																											
			Disconnected	1	Disconnect																											
			Connected	0	Connect																											

6.27.10.20 PSEL.RXD

Address offset: 0x514

Pin select for RXD

Bit number	31	30	29	28	27	26	25	24	23	22	21	20	19	18	17	16	15	14	13	12	11	10	9	8	7	6	5	4	3	2	1	0
ID	C																											A	A	A	A	A
Reset 0xFFFFFFFF	1	1	1	1	1	1	1	1	1	1	1	1	1	1	1	1	1	1	1	1	1	1	1	1	1	1	1	1	1	1	1	
ID	Acce	Field	Value ID	Value	Description																											
A	RW	PIN		[0..31]	Pin number																											
C	RW	CONNECT			Connection																											
			Disconnected	1	Disconnect																											
			Connected	0	Connect																											

6.27.10.21 RXD

Address offset: 0x518

RXD register

Bit number	31	30	29	28	27	26	25	24	23	22	21	20	19	18	17	16	15	14	13	12	11	10	9	8	7	6	5	4	3	2	1	0
ID	A A A A A A A A																															
Reset 0x00000000	0 0																															
ID	Acce	Field	Value ID	Value	Description																											
A	R	RXD			RX data received in previous transfers, double buffered																											

6.27.10.22 TXD

Address offset: 0x51C

TXD register

Bit number	31	30	29	28	27	26	25	24	23	22	21	20	19	18	17	16	15	14	13	12	11	10	9	8	7	6	5	4	3	2	1	0
ID	A A A A A A A A																															
Reset 0x00000000	0 0																															
ID	Acce	Field	Value ID	Value	Description																											
A	W	TXD			TX data to be transferred																											

6.27.10.23 BAUDRATE

Address offset: 0x524

Baud rate. Accuracy depends on the HFCLK source selected.

Bit number	31	30	29	28	27	26	25	24	23	22	21	20	19	18	17	16	15	14	13	12	11	10	9	8	7	6	5	4	3	2	1	0
ID	A A																															
Reset 0x04000000	0 0 0 0 0 1 0																															
ID	Acce	Field	Value ID	Value	Description																											
A	RW	BAUDRATE			Baud rate																											
			Baud1200	0x0004F000	1200 baud (actual rate: 1205)																											
			Baud2400	0x0009D000	2400 baud (actual rate: 2396)																											
			Baud4800	0x0013B000	4800 baud (actual rate: 4808)																											
			Baud9600	0x00275000	9600 baud (actual rate: 9598)																											
			Baud14400	0x003B0000	14400 baud (actual rate: 14414)																											
			Baud19200	0x004EA000	19200 baud (actual rate: 19208)																											
			Baud28800	0x0075F000	28800 baud (actual rate: 28829)																											
			Baud31250	0x00800000	31250 baud																											
			Baud38400	0x009D5000	38400 baud (actual rate: 38462)																											
			Baud56000	0x00E50000	56000 baud (actual rate: 55944)																											
			Baud57600	0x00EBF000	57600 baud (actual rate: 57762)																											
			Baud76800	0x013A9000	76800 baud (actual rate: 76923)																											
			Baud115200	0x01D7E000	115200 baud (actual rate: 115942)																											
			Baud230400	0x03AFB000	230400 baud (actual rate: 231884)																											
			Baud250000	0x04000000	250000 baud																											
			Baud460800	0x075F7000	460800 baud (actual rate: 470588)																											
			Baud921600	0x0EBED000	921600 baud (actual rate: 941176)																											
			Baud1M	0x10000000	1Mega baud																											

6.27.10.24 CONFIG

Address offset: 0x56C

Configuration of parity and hardware flow control

Bit number	31 30 29 28 27 26 25 24 23 22 21 20 19 18 17 16 15 14 13 12 11 10 9 8 7 6 5 4 3 2 1 0																																		
ID																															C	B	B	B	A
Reset 0x00000000	0 0																																		
ID	Acce	Field	Value ID	Value	Description																														
A	RW	HWFC	Disabled	0	Disabled																														
			Enabled	1	Enabled																														
B	RW	PARITY	Excluded	0x0	Exclude parity bit																														
			Included	0x7	Include parity bit																														
C	RW	STOP	One	0	One stop bit																														
			Two	1	Two stop bits																														

6.27.11 Electrical specification

6.27.11.1 UART electrical specification

Symbol	Description	Min.	Typ.	Max.	Units
f _{UART}	Baud rate for UART ³² .			1000	kbps
t _{UART,CTSH}	CTS high time	1			μs
t _{UART,START}	Time from STARTRX/STARTTX task to transmission started		1		μs

6.28 UARTE — Universal asynchronous receiver/transmitter with EasyDMA

The Universal asynchronous receiver/transmitter with EasyDMA (UARTE) offers fast, full-duplex, asynchronous serial communication with built-in flow control (CTS, RTS) support in hardware at a rate up to 1 Mbps, and EasyDMA data transfer from/to RAM.

Listed here are the main features for UARTE:

- Full-duplex operation
- Automatic hardware flow control
- Optional even parity bit checking and generation
- EasyDMA
- Up to 1 Mbps baudrate
- Return to IDLE between transactions supported (when using HW flow control)
- One or two stop bit
- Least significant bit (LSB) first

³² High baud rates may require GPIOs to be set as High Drive, see GPIO chapter for more details.

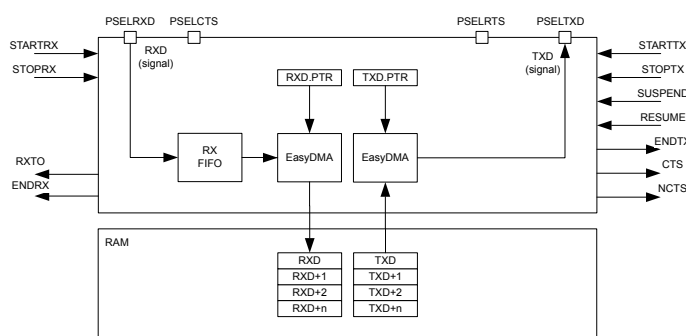

Figure 133: UARTE configuration

The GPIOs used for each UART interface can be chosen from any GPIO on the device and are independently configurable. This enables great flexibility in device pinout and efficient use of board space and signal routing.

Note: External crystal oscillator must be enabled to obtain sufficient clock accuracy for stable communication. See [CLOCK — Clock control](#) on page 62 for more information.

6.28.1 EasyDMA

The UARTE implements EasyDMA for reading and writing to and from the RAM.

If the TXD.PTR and the RXD.PTR are not pointing to the Data RAM region, an EasyDMA transfer may result in a HardFault or RAM corruption. See [Memory](#) on page 17 for more information about the different memory regions.

The .PTR and .MAXCNT registers are double-buffered. They can be updated and prepared for the next RX/TX transmission immediately after having received the RXSTARTED/TXSTARTED event.

The ENDRX/ENDTX event indicates that EasyDMA has finished accessing respectively the RX/TX buffer in RAM.

6.28.2 Transmission

The first step of a DMA transmission is storing bytes in the transmit buffer and configuring EasyDMA. This is achieved by writing the initial address pointer to TXD.PTR, and the number of bytes in the RAM buffer to TXD.MAXCNT. The UARTE transmission is started by triggering the STARTTX task.

After each byte has been sent over the TXD line, a TXDRDY event will be generated.

When all bytes in the TXD buffer, as specified in the TXD.MAXCNT register, have been transmitted, the UARTE transmission will end automatically and an ENDTX event will be generated.

A UARTE transmission sequence is stopped by triggering the STOPTHX task, a TXSTOPPED event will be generated when the UARTE transmitter has stopped.

If the ENDTX event has not already been generated when the UARTE transmitter has come to a stop, the UARTE will generate the ENDTX event explicitly even though all bytes in the TXD buffer, as specified in the TXD.MAXCNT register, have not been transmitted.

If flow control is enabled through the HWFC field in the CONFIG register, a transmission will be automatically suspended when CTS is deactivated and resumed when CTS is activated again, as illustrated in [UARTE transmission](#) on page 365. A byte that is in transmission when CTS is deactivated will be fully transmitted before the transmission is suspended.

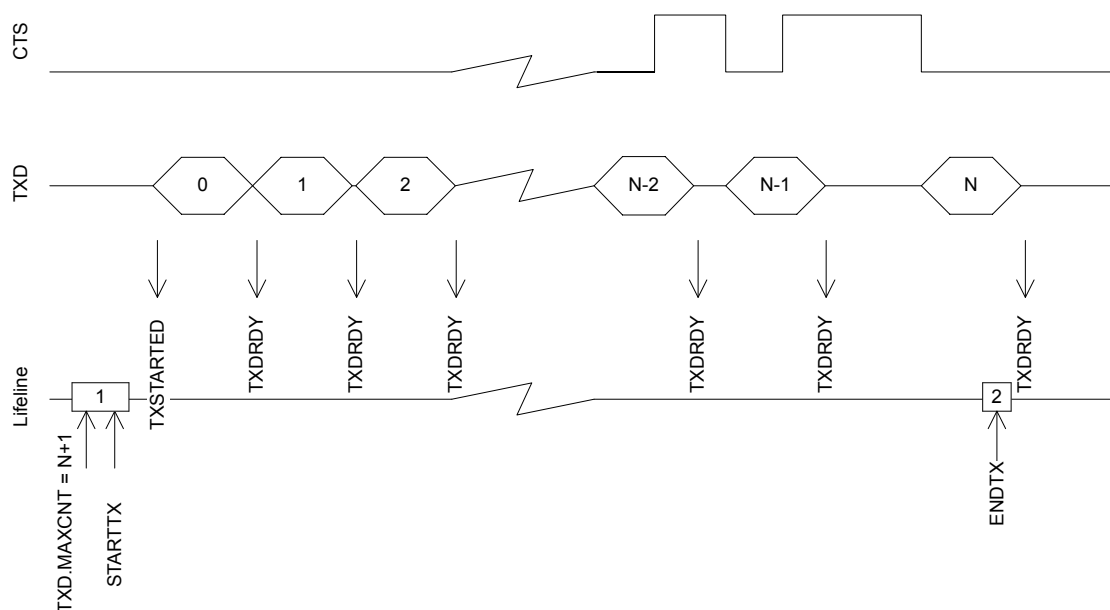

Figure 134: UART transmission

The UART transmitter will be in its lowest activity level, and consume the least amount of energy, when it is stopped, i.e. before it is started via STARTTX or after it has been stopped via STOPTH and the TXSTOPPED event has been generated. See [POWER — Power supply](#) on page 49 for more information about power modes.

6.28.3 Reception

The UART receiver is started by triggering the STARTRX task. The UART receiver is using EasyDMA to store incoming data in an RX buffer in RAM.

The RX buffer is located at the address specified in the RXD.PTR register. The RXD.PTR register is double-buffered and it can be updated and prepared for the next STARTRX task immediately after the RXSTARTED event is generated. The size of the RX buffer is specified in the RXD.MAXCNT register and the UART will generate an ENDRX event when it has filled up the RX buffer, see [UART reception](#) on page 366.

For each byte received over the RXD line, an RXDRDY event will be generated. This event is likely to occur before the corresponding data has been transferred to Data RAM.

The RXD.AMOUNT register can be queried following an ENDRX event to see how many new bytes have been transferred to the RX buffer in RAM since the previous ENDRX event.

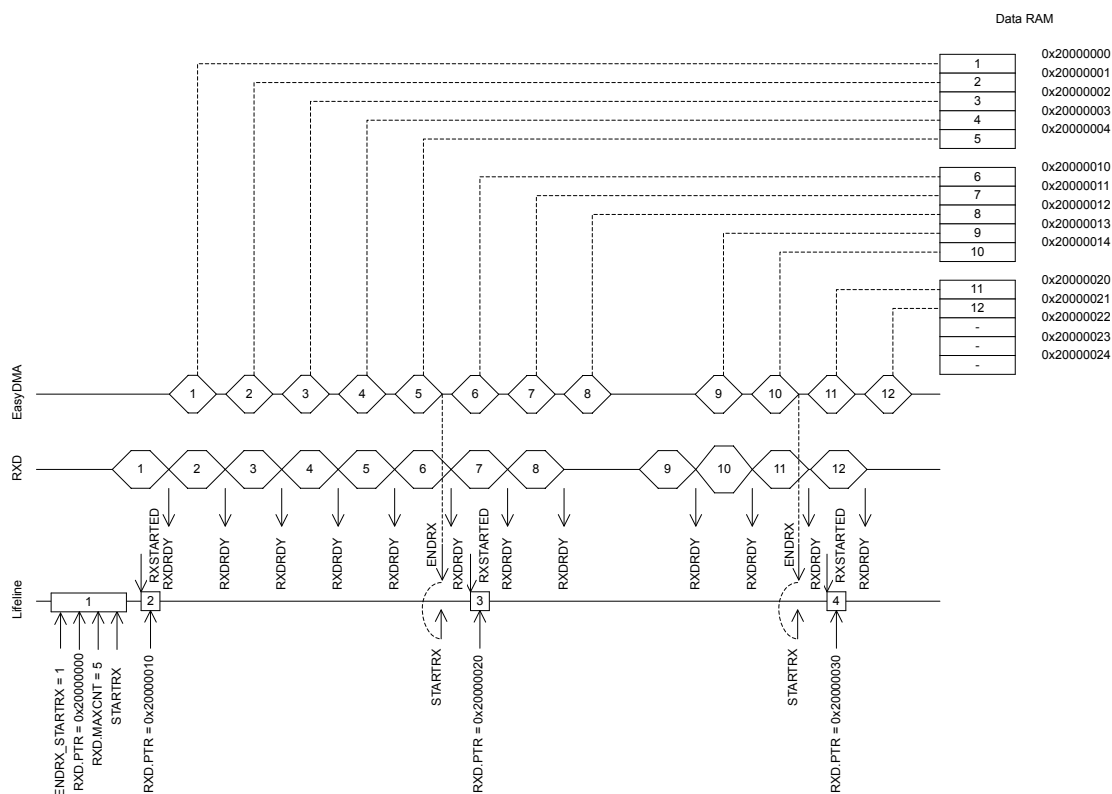

Figure 135: UARTE reception

The UARTE receiver is stopped by triggering the STOPRX task. An RXTO event is generated when the UARTE has stopped. The UARTE will make sure that an impending ENDRX event will be generated before the RXTO event is generated. This means that the UARTE will guarantee that no ENDRX event will be generated after RXTO, unless the UARTE is restarted or a FLUSHRX command is issued after the RXTO event is generated.

Important: If the ENDRX event has not already been generated when the UARTE receiver has come to a stop, which implies that all pending content in the RX FIFO has been moved to the RX buffer, the UARTE will generate the ENDRX event explicitly even though the RX buffer is not full. In this scenario the ENDRX event will be generated before the RXTO event is generated.

To be able to know how many bytes have actually been received into the RX buffer, the CPU can read the RXD.AMOUNT register following the ENDRX event or the RXTO event.

The UARTE is able to receive up to four bytes after the STOPRX task has been triggered as long as these are sent in succession immediately after the RTS signal is deactivated. This is possible because after the RTS is deactivated the UARTE is able to receive bytes for an extended period equal to the time it takes to send 4 bytes on the configured baud rate.

After the RXTO event is generated the internal RX FIFO may still contain data, and to move this data to RAM the FLUSHRX task must be triggered. To make sure that this data does not overwrite data in the RX buffer, the RX buffer should be emptied or the RXD.PTR should be updated before the FLUSHRX task is triggered. To make sure that all data in the RX FIFO is moved to the RX buffer, the RXD.MAXCNT register must be set to $RXD.MAXCNT > 4$, see [UARTE reception with forced stop via STOPRX](#) on page 367. The UARTE will generate the ENDRX event after completing the FLUSHRX task even if the RX FIFO was empty or if the RX buffer does not get filled up. To be able to know how many bytes have actually been received into the RX buffer in this case, the CPU can read the RXD.AMOUNT register following the ENDRX event.

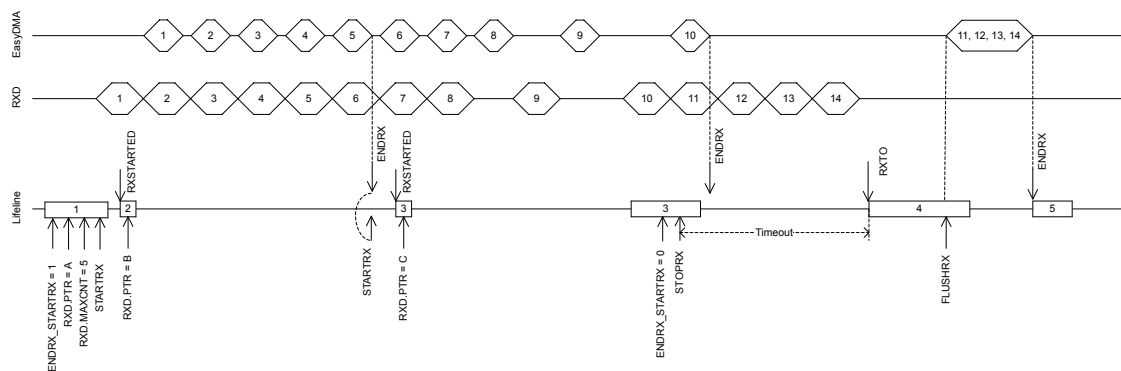

Figure 136: UARTE reception with forced stop via STOPRX

If HW flow control is enabled through the HWFC field in the CONFIG register, the RTS signal will be deactivated when the receiver is stopped via the STOPRX task or when the UARTE is only able to receive four more bytes in its internal RX FIFO.

With flow control disabled, the UARTE will function in the same way as when the flow control is enabled except that the RTS line will not be used. This means that no signal will be generated when the UARTE has reached the point where it is only able to receive four more bytes in its internal RX FIFO. Data received when the internal RX FIFO is filled up, will be lost.

The UARTE receiver will be in its lowest activity level, and consume the least amount of energy, when it is stopped, i.e. before it is started via STARTRX or after it has been stopped via STOPRX and the RXTO event has been generated. See [POWER — Power supply](#) on page 49 for more information about power modes.

6.28.4 Error conditions

An ERROR event, in the form of a framing error, will be generated if a valid stop bit is not detected in a frame. Another ERROR event, in the form of a break condition, will be generated if the RXD line is held active low for longer than the length of a data frame. Effectively, a framing error is always generated before a break condition occurs.

An ERROR event will not stop reception. If the error was a parity error, the received byte will still be transferred into Data RAM, and so will following incoming bytes. If there was a framing error (wrong stop bit), that specific byte will NOT be stored into Data RAM, but following incoming bytes will.

6.28.5 Using the UARTE without flow control

If flow control is not enabled, the interface will behave as if the CTS and RTS lines are kept active all the time.

6.28.6 Parity and stop bit configuration

Automatic even parity generation for both transmission and reception can be configured using the register [CONFIG](#) on page 381. See the register description for details.

The amount of stop bits can also be configured through the register [CONFIG](#) on page 381.

6.28.7 Low power

When putting the system in low power and the peripheral is not needed, lowest possible power consumption is achieved by stopping, and then disabling the peripheral.

The STOPTH and STOPRX tasks may not be always needed (the peripheral might already be stopped), but if STOPTH and/or STOPRX is sent, software shall wait until the TXSTOPPED and/or RXTO event is received in response, before disabling the peripheral through the ENABLE register.

6.28.8 Pin configuration

The different signals RXD, CTS (Clear To Send, active low), RTS (Request To Send, active low), and TXD associated with the UARTE are mapped to physical pins according to the configuration specified in the PSEL.RXD, PSEL.CTS, PSEL.RTS, and PSEL.TXD registers respectively.

The PSEL.RXD, PSEL.CTS, PSEL.RTS, and PSEL.TXD registers and their configurations are only used as long as the UARTE is enabled, and retained only for the duration the device is in ON mode. PSEL.RXD, PSEL.RTS, PSEL.RTS and PSEL.TXD must only be configured when the UARTE is disabled.

To secure correct signal levels on the pins by the UARTE when the system is in OFF mode, the pins must be configured in the GPIO peripheral as described in [GPIO configuration before enabling peripheral](#) on page 368.

Only one peripheral can be assigned to drive a particular GPIO pin at a time. Failing to do so may result in unpredictable behavior.

UARTE signal	UARTE pin	Direction	Output value
RXD	As specified in PSEL.RXD	Input	Not applicable
CTS	As specified in PSEL.CTS	Input	Not applicable
RTS	As specified in PSEL.RTS	Output	1
TXD	As specified in PSEL.TXD	Output	1

Table 108: GPIO configuration before enabling peripheral

6.28.9 Registers

Base address	Peripheral	Instance	Description	Configuration
0x40002000	UARTE	UARTE0	Universal asynchronous receiver/transmitter with EasyDMA	

Table 109: Instances

Register	Offset	Description
TASKS_STARTRX	0x000	Start UART receiver
TASKS_STOPRX	0x004	Stop UART receiver
TASKS_STARTTX	0x008	Start UART transmitter
TASKS_STOPTX	0x00C	Stop UART transmitter
TASKS_FLUSHRX	0x02C	Flush RX FIFO into RX buffer
EVENTS_CTS	0x100	CTS is activated (set low). Clear To Send.
EVENTS_NCTS	0x104	CTS is deactivated (set high). Not Clear To Send.
EVENTS_RXDRDY	0x108	Data received in RXD (but potentially not yet transferred to Data RAM)
EVENTS_ENDRX	0x110	Receive buffer is filled up
EVENTS_TXDRDY	0x11C	Data sent from TXD
EVENTS_ENDTX	0x120	Last TX byte transmitted
EVENTS_ERROR	0x124	Error detected
EVENTS_RXT0	0x144	Receiver timeout
EVENTS_RXSTARTED	0x14C	UART receiver has started
EVENTS_TXSTARTED	0x150	UART transmitter has started
EVENTS_TXSTOPPED	0x158	Transmitter stopped
SHORTS	0x200	Shortcuts between local events and tasks
INTEN	0x300	Enable or disable interrupt
INTENSET	0x304	Enable interrupt
INTENCLR	0x308	Disable interrupt

Register	Offset	Description
ERRORSRC	0x480	Error source
		Note : this register is read / write one to clear.
ENABLE	0x500	Enable UART
PSEL.RTS	0x508	Pin select for RTS signal
PSEL.TXD	0x50C	Pin select for TXD signal
PSEL.CTS	0x510	Pin select for CTS signal
PSEL.RXD	0x514	Pin select for RXD signal
BAUDRATE	0x524	Baud rate. Accuracy depends on the HFCLK source selected.
RXD.PTR	0x534	Data pointer
RXD.MAXCNT	0x538	Maximum number of bytes in receive buffer
RXD.AMOUNT	0x53C	Number of bytes transferred in the last transaction
TXD.PTR	0x544	Data pointer
TXD.MAXCNT	0x548	Maximum number of bytes in transmit buffer
TXD.AMOUNT	0x54C	Number of bytes transferred in the last transaction
CONFIG	0x56C	Configuration of parity and hardware flow control

Table 110: Register overview

6.28.9.1 TASKS_STARTRX

Address offset: 0x000

Start UART receiver

Bit number	31 30 29 28 27 26 25 24 23 22 21 20 19 18 17 16 15 14 13 12 11 10 9 8 7 6 5 4 3 2 1 0																														
ID	A																														
Reset 0x00000000	0 0																														
ID	Acces	Field	Value ID	Value	Description																										
A	W	TASKS_STARTRX			Start UART receiver																										
			Trigger	1	Trigger task																										

6.28.9.2 TASKS_STOPRX

Address offset: 0x004

Stop UART receiver

Bit number	31 30 29 28 27 26 25 24 23 22 21 20 19 18 17 16 15 14 13 12 11 10 9 8 7 6 5 4 3 2 1 0																														
ID	A																														
Reset 0x00000000	0 0																														
ID	Acces	Field	Value ID	Value	Description																										
A	W	TASKS_STOPRX			Stop UART receiver																										
			Trigger	1	Trigger task																										

6.28.9.3 TASKS_STARTTX

Address offset: 0x008

Start UART transmitter

Bit number	31	30	29	28	27	26	25	24	23	22	21	20	19	18	17	16	15	14	13	12	11	10	9	8	7	6	5	4	3	2	1	0
ID																																A
Reset 0x00000000	0 0																															
ID	Acce Field	Value ID	Value	Description																												
A	W	TASKS_STARTTX		Start UART transmitter																												
		Trigger	1	Trigger task																												

6.28.9.4 TASKS_STOPTX

Address offset: 0x00C

Stop UART transmitter

Bit number	31	30	29	28	27	26	25	24	23	22	21	20	19	18	17	16	15	14	13	12	11	10	9	8	7	6	5	4	3	2	1	0
ID																																A
Reset 0x00000000	0 0																															
ID	Acce Field	Value ID	Value	Description																												
A	W	TASKS_STOPTX		Stop UART transmitter																												
		Trigger	1	Trigger task																												

6.28.9.5 TASKS_FLUSHRX

Address offset: 0x02C

Flush RX FIFO into RX buffer

Bit number	31	30	29	28	27	26	25	24	23	22	21	20	19	18	17	16	15	14	13	12	11	10	9	8	7	6	5	4	3	2	1	0
ID																																A
Reset 0x00000000	0 0																															
ID	Acce Field	Value ID	Value	Description																												
A	W	TASKS_FLUSHRX		Flush RX FIFO into RX buffer																												
		Trigger	1	Trigger task																												

6.28.9.6 EVENTS_CTS

Address offset: 0x100

CTS is activated (set low). Clear To Send.

Bit number	31	30	29	28	27	26	25	24	23	22	21	20	19	18	17	16	15	14	13	12	11	10	9	8	7	6	5	4	3	2	1	0
ID																																A
Reset 0x00000000	0 0																															
ID	Acce Field	Value ID	Value	Description																												
A	RW	EVENTS_CTS		CTS is activated (set low). Clear To Send.																												
		NotGenerated	0	Event not generated																												
		Generated	1	Event generated																												

6.28.9.7 EVENTS_NCTS

Address offset: 0x104

CTS is deactivated (set high). Not Clear To Send.

Bit number	31	30	29	28	27	26	25	24	23	22	21	20	19	18	17	16	15	14	13	12	11	10	9	8	7	6	5	4	3	2	1	0	
ID																																A	
Reset	0x00000000																																
0	0	0	0	0	0	0	0	0	0	0	0	0	0	0	0	0	0	0	0	0	0	0	0	0	0	0	0	0	0	0	0	0	0
ID	Acce Field	Value ID	Value	Description																													
A	RW	EVENTS_NCTS		CTS is deactivated (set high). Not Clear To Send.																													
		NotGenerated	0	Event not generated																													
		Generated	1	Event generated																													

6.28.9.8 EVENTS_RXDRDY

Address offset: 0x108

Data received in RXD (but potentially not yet transferred to Data RAM)

Bit number	31	30	29	28	27	26	25	24	23	22	21	20	19	18	17	16	15	14	13	12	11	10	9	8	7	6	5	4	3	2	1	0
ID																																A
Reset	0x00000000																															
0	0	0	0	0	0	0	0	0	0	0	0	0	0	0	0	0	0	0	0	0	0	0	0	0	0	0	0	0	0	0	0	0
ID	Acce Field	Value ID	Value	Description																												
A	RW	EVENTS_RXDRDY		Data received in RXD (but potentially not yet transferred to Data RAM)																												
		NotGenerated	0	Event not generated																												
		Generated	1	Event generated																												

6.28.9.9 EVENTS_ENDRX

Address offset: 0x110

Receive buffer is filled up

Bit number	31	30	29	28	27	26	25	24	23	22	21	20	19	18	17	16	15	14	13	12	11	10	9	8	7	6	5	4	3	2	1	0
ID																																A
Reset	0x00000000																															
0	0	0	0	0	0	0	0	0	0	0	0	0	0	0	0	0	0	0	0	0	0	0	0	0	0	0	0	0	0	0	0	0
ID	Acce Field	Value ID	Value	Description																												
A	RW	EVENTS_ENDRX		Receive buffer is filled up																												
		NotGenerated	0	Event not generated																												
		Generated	1	Event generated																												

6.28.9.10 EVENTS_TXDRDY

Address offset: 0x11C

Data sent from TXD

Bit number	31	30	29	28	27	26	25	24	23	22	21	20	19	18	17	16	15	14	13	12	11	10	9	8	7	6	5	4	3	2	1	0
ID																																A
Reset	0x00000000																															
0	0	0	0	0	0	0	0	0	0	0	0	0	0	0	0	0	0	0	0	0	0	0	0	0	0	0	0	0	0	0	0	0
ID	Acce Field	Value ID	Value	Description																												
A	RW	EVENTS_TXDRDY		Data sent from TXD																												
		NotGenerated	0	Event not generated																												
		Generated	1	Event generated																												

6.28.9.11 EVENTS_ENDTX

Address offset: 0x120

Last TX byte transmitted

Bit number	31 30 29 28 27 26 25 24 23 22 21 20 19 18 17 16 15 14 13 12 11 10 9 8 7 6 5 4 3 2 1 0																														
ID	A																														
Reset 0x00000000	0 0																														
ID	Acce Field	Value ID	Value	Description																											
A	RW EVENTS_ENDTX			Last TX byte transmitted																											
		NotGenerated	0	Event not generated																											
		Generated	1	Event generated																											

6.28.9.12 EVENTS_ERROR

Address offset: 0x124

Error detected

Bit number	31 30 29 28 27 26 25 24 23 22 21 20 19 18 17 16 15 14 13 12 11 10 9 8 7 6 5 4 3 2 1 0																														
ID	A																														
Reset 0x00000000	0 0																														
ID	Acce Field	Value ID	Value	Description																											
A	RW EVENTS_ERROR			Error detected																											
		NotGenerated	0	Event not generated																											
		Generated	1	Event generated																											

6.28.9.13 EVENTS_RXTO

Address offset: 0x144

Receiver timeout

Bit number	31 30 29 28 27 26 25 24 23 22 21 20 19 18 17 16 15 14 13 12 11 10 9 8 7 6 5 4 3 2 1 0																														
ID	A																														
Reset 0x00000000	0 0																														
ID	Acce Field	Value ID	Value	Description																											
A	RW EVENTS_RXTO			Receiver timeout																											
		NotGenerated	0	Event not generated																											
		Generated	1	Event generated																											

6.28.9.14 EVENTS_RXSTARTED

Address offset: 0x14C

UART receiver has started

Bit number	31 30 29 28 27 26 25 24 23 22 21 20 19 18 17 16 15 14 13 12 11 10 9 8 7 6 5 4 3 2 1 0																														
ID	A																														
Reset 0x00000000	0 0																														
ID	Acce Field	Value ID	Value	Description																											
A	RW EVENTS_RXSTARTED			UART receiver has started																											
		NotGenerated	0	Event not generated																											
		Generated	1	Event generated																											

6.28.9.15 EVENTS_TXSTARTED

Address offset: 0x150

UART transmitter has started

Bit number	31	30	29	28	27	26	25	24	23	22	21	20	19	18	17	16	15	14	13	12	11	10	9	8	7	6	5	4	3	2	1	0
ID																																A
Reset 0x00000000	0 0																															
ID	Acce Field	Value ID	Value	Description																												
A	RW EVENTS_TXSTARTED			UART transmitter has started																												
		NotGenerated	0	Event not generated																												
		Generated	1	Event generated																												

6.28.9.16 EVENTS_TXSTOPPED

Address offset: 0x158

Transmitter stopped

Bit number	31	30	29	28	27	26	25	24	23	22	21	20	19	18	17	16	15	14	13	12	11	10	9	8	7	6	5	4	3	2	1	0
ID																																A
Reset 0x00000000	0 0																															
ID	Acce Field	Value ID	Value	Description																												
A	RW EVENTS_TXSTOPPED			Transmitter stopped																												
		NotGenerated	0	Event not generated																												
		Generated	1	Event generated																												

6.28.9.17 SHORTS

Address offset: 0x200

Shortcuts between local events and tasks

Bit number	31	30	29	28	27	26	25	24	23	22	21	20	19	18	17	16	15	14	13	12	11	10	9	8	7	6	5	4	3	2	1	0
ID																													D	C		
Reset 0x00000000	0 0																															
ID	Acce Field	Value ID	Value	Description																												
C	RW ENDRX_STARTRX			Shortcut between event ENDRX and task STARTRX																												
		Disabled	0	Disable shortcut																												
		Enabled	1	Enable shortcut																												
D	RW ENDRX_STOPRX			Shortcut between event ENDRX and task STOPRX																												
		Disabled	0	Disable shortcut																												
		Enabled	1	Enable shortcut																												

6.28.9.18 INTEN

Address offset: 0x300

Enable or disable interrupt

Bit number	31	30	29	28	27	26	25	24	23	22	21	20	19	18	17	16	15	14	13	12	11	10	9	8	7	6	5	4	3	2	1	0
ID											L	J	I	H											G	F	E	D	C	B	A	
Reset 0x00000000	0 0																															
ID	Acce Field	Value ID	Value	Description																												
A	RW CTS			Enable or disable interrupt for event CTS																												
		Disabled	0	Disable																												
		Enabled	1	Enable																												
B	RW NCTS			Enable or disable interrupt for event NCTS																												
		Disabled	0	Disable																												
		Enabled	1	Enable																												

Bit number	31 30 29 28 27 26 25 24 23 22 21 20 19 18 17 16 15 14 13 12 11 10 9 8 7 6 5 4 3 2 1 0																														
ID	L J I H															G F E D C B A															
Reset 0x00000000	0 0																														
ID	Acce Field	Value ID	Value	Description																											
C	RW RXDRDY	Disabled	0	Disable																											
		Enabled	1	Enable																											
D	RW ENDRX	Disabled	0	Disable																											
		Enabled	1	Enable																											
E	RW TXDRDY	Disabled	0	Disable																											
		Enabled	1	Enable																											
F	RW ENDTX	Disabled	0	Disable																											
		Enabled	1	Enable																											
G	RW ERROR	Disabled	0	Disable																											
		Enabled	1	Enable																											
H	RW RXTO	Disabled	0	Disable																											
		Enabled	1	Enable																											
I	RW RXSTARTED	Disabled	0	Disable																											
		Enabled	1	Enable																											
J	RW TXSTARTED	Disabled	0	Disable																											
		Enabled	1	Enable																											
L	RW TXSTOPPED	Disabled	0	Disable																											
		Enabled	1	Enable																											

6.28.9.19 INTENSET

Address offset: 0x304

Enable interrupt

Bit number	31 30 29 28 27 26 25 24 23 22 21 20 19 18 17 16 15 14 13 12 11 10 9 8 7 6 5 4 3 2 1 0																														
ID	L J I H															G F E D C B A															
Reset 0x00000000	0 0																														
ID	Acce Field	Value ID	Value	Description																											
A	RW CTS	Set	1	Write '1' to enable interrupt for event CTS																											
		Disabled	0	Enable																											
		Enabled	1	Read: Disabled																											
B	RW NCTS	Set	1	Write '1' to enable interrupt for event NCTS																											
		Disabled	0	Enable																											
		Enabled	1	Read: Disabled																											
C	RW RXDRDY	Set	1	Write '1' to enable interrupt for event RXDRDY																											
		Disabled	0	Enable																											
		Enabled	1	Read: Disabled																											

Bit number	31 30 29 28 27 26 25 24 23 22 21 20 19 18 17 16 15 14 13 12 11 10 9 8 7 6 5 4 3 2 1 0																														
ID	L J I H																G F E D C B A														
Reset 0x00000000	0 0																														
ID	Acce Field	Value ID	Value	Description																											
D	RW ENDRX			Write '1' to enable interrupt for event ENDRX																											
		Set	1	Enable																											
		Disabled	0	Read: Disabled																											
E	RW TXDRDY	Enabled	1	Read: Enabled																											
		Set	1	Enable																											
		Disabled	0	Read: Disabled																											
F	RW ENDTX	Enabled	1	Read: Enabled																											
		Set	1	Enable																											
		Disabled	0	Read: Disabled																											
G	RW ERROR	Enabled	1	Read: Enabled																											
		Set	1	Enable																											
		Disabled	0	Read: Disabled																											
H	RW RXTO	Enabled	1	Read: Enabled																											
		Set	1	Enable																											
		Disabled	0	Read: Disabled																											
I	RW RXSTARTED	Enabled	1	Read: Enabled																											
		Set	1	Enable																											
		Disabled	0	Read: Disabled																											
J	RW TXSTARTED	Enabled	1	Read: Enabled																											
		Set	1	Enable																											
		Disabled	0	Read: Disabled																											
L	RW TXSTOPPED	Enabled	1	Read: Enabled																											
		Set	1	Enable																											
		Disabled	0	Read: Disabled																											

6.28.9.20 INTENCLR

Address offset: 0x308

Disable interrupt

Bit number	31 30 29 28 27 26 25 24 23 22 21 20 19 18 17 16 15 14 13 12 11 10 9 8 7 6 5 4 3 2 1 0																														
ID	L J I H																G F E D C B A														
Reset 0x00000000	0 0																														
ID	Acce Field	Value ID	Value	Description																											
A	RW CTS			Write '1' to disable interrupt for event CTS																											
		Clear	1	Disable																											
		Disabled	0	Read: Disabled																											
B	RW NCTS	Enabled	1	Read: Enabled																											
		Clear	1	Disable																											
		Disabled	0	Read: Disabled																											

Bit number		31 30 29 28 27 26 25 24 23 22 21 20 19 18 17 16 15 14 13 12 11 10 9 8 7 6 5 4 3 2 1 0																														
ID		L J I H																G F E D C B A														
Reset 0x00000000		0 0																														
ID	Acce Field	Value ID	Value	Description																												
		Enabled	1	Read: Enabled																												
C	RW RXDRDY			Write '1' to disable interrupt for event RXDRDY																												
		Clear	1	Disable																												
		Disabled	0	Read: Disabled																												
		Enabled	1	Read: Enabled																												
D	RW ENDRX			Write '1' to disable interrupt for event ENDRX																												
		Clear	1	Disable																												
		Disabled	0	Read: Disabled																												
		Enabled	1	Read: Enabled																												
E	RW TXDRDY			Write '1' to disable interrupt for event TXDRDY																												
		Clear	1	Disable																												
		Disabled	0	Read: Disabled																												
		Enabled	1	Read: Enabled																												
F	RW ENDTX			Write '1' to disable interrupt for event ENDTX																												
		Clear	1	Disable																												
		Disabled	0	Read: Disabled																												
		Enabled	1	Read: Enabled																												
G	RW ERROR			Write '1' to disable interrupt for event ERROR																												
		Clear	1	Disable																												
		Disabled	0	Read: Disabled																												
		Enabled	1	Read: Enabled																												
H	RW RXTO			Write '1' to disable interrupt for event RXTO																												
		Clear	1	Disable																												
		Disabled	0	Read: Disabled																												
		Enabled	1	Read: Enabled																												
I	RW RXSTARTED			Write '1' to disable interrupt for event RXSTARTED																												
		Clear	1	Disable																												
		Disabled	0	Read: Disabled																												
		Enabled	1	Read: Enabled																												
J	RW TXSTARTED			Write '1' to disable interrupt for event TXSTARTED																												
		Clear	1	Disable																												
		Disabled	0	Read: Disabled																												
		Enabled	1	Read: Enabled																												
L	RW TXSTOPPED			Write '1' to disable interrupt for event TXSTOPPED																												
		Clear	1	Disable																												
		Disabled	0	Read: Disabled																												
		Enabled	1	Read: Enabled																												

6.28.9.21 ERRORSRC

Address offset: 0x480

Error source

Note : this register is read / write one to clear.

Bit number	31 30 29 28 27 26 25 24 23 22 21 20 19 18 17 16 15 14 13 12 11 10 9 8 7 6 5 4 3 2 1 0																															
ID																																D C B A
Reset	0x00000000																															0 0
ID	Acce Field	Value ID	Value	Description																												
A	RW	OVERRUN		Overrun error																												
				A start bit is received while the previous data still lies in RXD. (Previous data is lost.)																												
		NotPresent	0	Read: error not present																												
		Present	1	Read: error present																												
B	RW	PARITY		Parity error																												
				A character with bad parity is received, if HW parity check is enabled.																												
		NotPresent	0	Read: error not present																												
		Present	1	Read: error present																												
C	RW	FRAMING		Framing error occurred																												
				A valid stop bit is not detected on the serial data input after all bits in a character have been received.																												
		NotPresent	0	Read: error not present																												
		Present	1	Read: error present																												
D	RW	BREAK		Break condition																												
				The serial data input is '0' for longer than the length of a data frame. (The data frame length is 10 bits without parity bit, and 11 bits with parity bit.).																												
		NotPresent	0	Read: error not present																												
		Present	1	Read: error present																												

6.28.9.22 ENABLE

Address offset: 0x500

Enable UART

Bit number	31 30 29 28 27 26 25 24 23 22 21 20 19 18 17 16 15 14 13 12 11 10 9 8 7 6 5 4 3 2 1 0																															
ID																																A A A A
Reset	0x00000000																															0 0
ID	Acce Field	Value ID	Value	Description																												
A	RW	ENABLE		Enable or disable UARTE																												
				Disable UARTE																												
		Disabled	0	Disable UARTE																												
		Enabled	8	Enable UARTE																												

6.28.9.23 PSEL.RTS

Address offset: 0x508

Pin select for RTS signal

Bit number	31	30	29	28	27	26	25	24	23	22	21	20	19	18	17	16	15	14	13	12	11	10	9	8	7	6	5	4	3	2	1	0
ID	C																															
Reset 0xFFFFFFFF	1 1																															
ID	Acce	Field	Value ID	Value	Description																											
A	RW	PIN		[0..31]	Pin number																											
C	RW	CONNECT			Connection																											
			Disconnected	1	Disconnect																											
			Connected	0	Connect																											

6.28.9.24 PSEL.TXD

Address offset: 0x50C

Pin select for TXD signal

Bit number	31	30	29	28	27	26	25	24	23	22	21	20	19	18	17	16	15	14	13	12	11	10	9	8	7	6	5	4	3	2	1	0
ID	C																															
Reset 0xFFFFFFFF	1 1																															
ID	Acce	Field	Value ID	Value	Description																											
A	RW	PIN		[0..31]	Pin number																											
C	RW	CONNECT			Connection																											
			Disconnected	1	Disconnect																											
			Connected	0	Connect																											

6.28.9.25 PSEL.CTS

Address offset: 0x510

Pin select for CTS signal

Bit number	31	30	29	28	27	26	25	24	23	22	21	20	19	18	17	16	15	14	13	12	11	10	9	8	7	6	5	4	3	2	1	0
ID	C																															
Reset 0xFFFFFFFF	1 1																															
ID	Acce	Field	Value ID	Value	Description																											
A	RW	PIN		[0..31]	Pin number																											
C	RW	CONNECT			Connection																											
			Disconnected	1	Disconnect																											
			Connected	0	Connect																											

6.28.9.26 PSEL.RXD

Address offset: 0x514

Pin select for RXD signal

Bit number	31	30	29	28	27	26	25	24	23	22	21	20	19	18	17	16	15	14	13	12	11	10	9	8	7	6	5	4	3	2	1	0
ID	C																															
Reset 0xFFFFFFFF	1 1																															
ID	Acce	Field	Value ID	Value	Description																											
A	RW	PIN		[0..31]	Pin number																											
C	RW	CONNECT			Connection																											
			Disconnected	1	Disconnect																											
			Connected	0	Connect																											

6.28.9.27 BAUDRATE

Address offset: 0x524

Baud rate. Accuracy depends on the HFCLK source selected.

Bit number	31	30	29	28	27	26	25	24	23	22	21	20	19	18	17	16	15	14	13	12	11	10	9	8	7	6	5	4	3	2	1	0
ID	A	A	A	A	A	A	A	A	A	A	A	A	A	A	A	A	A	A	A	A	A	A	A	A	A	A	A	A	A	A	A	A
Reset 0x04000000	0	0	0	0	0	1	0	0	0	0	0	0	0	0	0	0	0	0	0	0	0	0	0	0	0	0	0	0	0	0	0	
ID	Acce	Field	Value ID	Value	Description																											
A	RW	BAUDRATE			Baud rate																											
			Baud1200	0x0004F000	1200 baud (actual rate: 1205)																											
			Baud2400	0x0009D000	2400 baud (actual rate: 2396)																											
			Baud4800	0x0013B000	4800 baud (actual rate: 4808)																											
			Baud9600	0x00275000	9600 baud (actual rate: 9598)																											
			Baud14400	0x003AF000	14400 baud (actual rate: 14401)																											
			Baud19200	0x004EA000	19200 baud (actual rate: 19208)																											
			Baud28800	0x0075C000	28800 baud (actual rate: 28777)																											
			Baud31250	0x00800000	31250 baud																											
			Baud38400	0x009D0000	38400 baud (actual rate: 38369)																											
			Baud56000	0x00E50000	56000 baud (actual rate: 55944)																											
			Baud57600	0x00EB0000	57600 baud (actual rate: 57554)																											
			Baud76800	0x013A9000	76800 baud (actual rate: 76923)																											
			Baud115200	0x01D60000	115200 baud (actual rate: 115108)																											
			Baud230400	0x03B00000	230400 baud (actual rate: 231884)																											
			Baud250000	0x04000000	250000 baud																											
			Baud460800	0x07400000	460800 baud (actual rate: 457143)																											
			Baud921600	0x0F000000	921600 baud (actual rate: 941176)																											
			Baud1M	0x10000000	1Mega baud																											

6.28.9.28 RXD.PTR

Address offset: 0x534

Data pointer

Bit number	31	30	29	28	27	26	25	24	23	22	21	20	19	18	17	16	15	14	13	12	11	10	9	8	7	6	5	4	3	2	1	0
ID	A	A	A	A	A	A	A	A	A	A	A	A	A	A	A	A	A	A	A	A	A	A	A	A	A	A	A	A	A	A	A	
Reset 0x00000000	0	0	0	0	0	0	0	0	0	0	0	0	0	0	0	0	0	0	0	0	0	0	0	0	0	0	0	0	0	0	0	
ID	Acce	Field	Value ID	Value	Description																											
A	RW	PTR			Data pointer																											

Note: See the memory chapter for details about which memories are available for EasyDMA.

6.28.9.29 RXD.MAXCNT

Address offset: 0x538

Maximum number of bytes in receive buffer

Bit number	31	30	29	28	27	26	25	24	23	22	21	20	19	18	17	16	15	14	13	12	11	10	9	8	7	6	5	4	3	2	1	0
ID	A A A A A A A A A A																															
Reset	0x00000000																															
Reset	0 0																															
ID	Acce	Field	Value ID	Value	Description																											
A	RW	MAXCNT		[1..0x3FF]	Maximum number of bytes in receive buffer																											

6.28.9.30 RXD.AMOUNT

Address offset: 0x53C

Number of bytes transferred in the last transaction

Bit number	31	30	29	28	27	26	25	24	23	22	21	20	19	18	17	16	15	14	13	12	11	10	9	8	7	6	5	4	3	2	1	0
ID	A A A A A A A A A A																															
Reset	0x00000000																															
Reset	0 0																															
ID	Acce	Field	Value ID	Value	Description																											
A	R	AMOUNT		[1..0x3FF]	Number of bytes transferred in the last transaction																											

6.28.9.31 TXD.PTR

Address offset: 0x544

Data pointer

Bit number	31	30	29	28	27	26	25	24	23	22	21	20	19	18	17	16	15	14	13	12	11	10	9	8	7	6	5	4	3	2	1	0
ID	A A																															
Reset	0x00000000																															
Reset	0 0																															
ID	Acce	Field	Value ID	Value	Description																											
A	RW	PTR			Data pointer																											

Note: See the memory chapter for details about which memories are available for EasyDMA.

6.28.9.32 TXD.MAXCNT

Address offset: 0x548

Maximum number of bytes in transmit buffer

Bit number	31	30	29	28	27	26	25	24	23	22	21	20	19	18	17	16	15	14	13	12	11	10	9	8	7	6	5	4	3	2	1	0
ID	A A A A A A A A A A																															
Reset	0x00000000																															
Reset	0 0																															
ID	Acce	Field	Value ID	Value	Description																											
A	RW	MAXCNT		[1..0x3FF]	Maximum number of bytes in transmit buffer																											

6.28.9.33 TXD.AMOUNT

Address offset: 0x54C

Number of bytes transferred in the last transaction

Bit number	31	30	29	28	27	26	25	24	23	22	21	20	19	18	17	16	15	14	13	12	11	10	9	8	7	6	5	4	3	2	1	0
ID	A A A A A A A A A A																															
Reset	0x00000000																															
Reset	0 0																															
ID	Acce	Field	Value ID	Value	Description																											
A	R	AMOUNT		[1..0x3FF]	Number of bytes transferred in the last transaction																											

6.28.9.34 CONFIG

Address offset: 0x56C

Configuration of parity and hardware flow control

Bit number	31	30	29	28	27	26	25	24	23	22	21	20	19	18	17	16	15	14	13	12	11	10	9	8	7	6	5	4	3	2	1	0
ID	C B B B A																															
Reset	0x00000000																															
Reset	0 0																															
ID	Acce	Field	Value ID	Value	Description																											
A	RW	HWFC	Disabled	0	Disabled																											
			Enabled	1	Enabled																											
B	RW	PARITY	Excluded	0x0	Exclude parity bit																											
			Included	0x7	Include even parity bit																											
C	RW	STOP	One	0	One stop bit																											
			Two	1	Two stop bits																											

6.28.10 Electrical specification

6.28.10.1 UARTE electrical specification

Symbol	Description	Min.	Typ.	Max.	Units
f_{UARTE}	Baud rate for UARTE ³³ .			1000	kbps
$t_{UARTE,CTSH}$	CTS high time	1			μ s
$t_{UARTE,START}$	Time from STARTRX/STARTTX task to transmission started	μ s

6.29 WDT — Watchdog timer

A countdown watchdog timer using the low-frequency clock source (LFCLK) offers configurable and robust protection against application lock-up.

The watchdog timer is started by triggering the START task.

The watchdog can be paused during long CPU sleep periods for low power applications and when the debugger has halted the CPU. The watchdog is implemented as a down-counter that generates a TIMEOUT event when it wraps over after counting down to 0. When the watchdog timer is started through the START task, the watchdog counter is loaded with the value specified in the CRV register. This counter is also reloaded with the value specified in the CRV register when a reload request is granted.

³³ High baud rates may require GPIOs to be set as High Drive, see GPIO chapter for more details.

The watchdog's timeout period is given by:

$$\text{timeout [s]} = (\text{CRV} + 1) / 32768$$

When started, the watchdog will automatically force the 32.768 kHz RC oscillator on as long as no other 32.768 kHz clock source is running and generating the 32.768 kHz system clock, see chapter [CLOCK — Clock control](#) on page 62.

6.29.1 Reload criteria

The watchdog has eight separate reload request registers, which shall be used to request the watchdog to reload its counter with the value specified in the CRV register. To reload the watchdog counter, the special value 0x6E524635 needs to be written to all enabled reload registers.

One or more RR registers can be individually enabled through the RREN register.

6.29.2 Temporarily pausing the watchdog

By default, the watchdog will be active counting down the down-counter while the CPU is sleeping and when it is halted by the debugger. It is however possible to configure the watchdog to automatically pause while the CPU is sleeping as well as when it is halted by the debugger.

6.29.3 Watchdog reset

A TIMEOUT event will automatically lead to a watchdog reset.

See [Reset](#) on page 53 for more information about reset sources. If the watchdog is configured to generate an interrupt on the TIMEOUT event, the watchdog reset will be postponed with two 32.768 kHz clock cycles after the TIMEOUT event has been generated. Once the TIMEOUT event has been generated, the impending watchdog reset will always be effectuated.

The watchdog must be configured before it is started. After it is started, the watchdog's configuration registers, which comprise registers CRV, RREN, and CONFIG, will be blocked for further configuration.

The watchdog can be reset from several reset sources, see [Reset behavior](#) on page 54.

When the device starts running again, after a reset, or waking up from OFF mode, the watchdog configuration registers will be available for configuration again.

6.29.4 Registers

Base address	Peripheral	Instance	Description	Configuration
0x40010000	WDT	WDT	Watchdog timer	

Table 111: Instances

Register	Offset	Description
TASKS_START	0x000	Start the watchdog
EVENTS_TIMEOUT	0x100	Watchdog timeout
INTENSET	0x304	Enable interrupt
INTENCLR	0x308	Disable interrupt
RUNSTATUS	0x400	Run status
REQSTATUS	0x404	Request status
CRV	0x504	Counter reload value
RREN	0x508	Enable register for reload request registers

Register	Offset	Description
CONFIG	0x50C	Configuration register
RR[0]	0x600	Reload request 0
RR[1]	0x604	Reload request 1
RR[2]	0x608	Reload request 2
RR[3]	0x60C	Reload request 3
RR[4]	0x610	Reload request 4
RR[5]	0x614	Reload request 5
RR[6]	0x618	Reload request 6
RR[7]	0x61C	Reload request 7

Table 112: Register overview

6.29.4.1 TASKS_START

Address offset: 0x000

Start the watchdog

Bit number	31 30 29 28 27 26 25 24 23 22 21 20 19 18 17 16 15 14 13 12 11 10 9 8 7 6 5 4 3 2 1 0																															
ID																																A
Reset 0x00000000	0 0																															
ID	Acce Field	Value ID	Value	Description																												
A	W TASKS_START			Start the watchdog																												
		Trigger	1	Trigger task																												

6.29.4.2 EVENTS_TIMEOUT

Address offset: 0x100

Watchdog timeout

Bit number	31 30 29 28 27 26 25 24 23 22 21 20 19 18 17 16 15 14 13 12 11 10 9 8 7 6 5 4 3 2 1 0																															
ID																																A
Reset 0x00000000	0 0																															
ID	Acce Field	Value ID	Value	Description																												
A	RW EVENTS_TIMEOUT			Watchdog timeout																												
		NotGenerated	0	Event not generated																												
		Generated	1	Event generated																												

6.29.4.3 INTENSET

Address offset: 0x304

Enable interrupt

Bit number	31 30 29 28 27 26 25 24 23 22 21 20 19 18 17 16 15 14 13 12 11 10 9 8 7 6 5 4 3 2 1 0																															
ID																																A
Reset 0x00000000	0 0																															
ID	Acce Field	Value ID	Value	Description																												
A	RW TIMEOUT			Write '1' to enable interrupt for event TIMEOUT																												
		Set	1	Enable																												
		Disabled	0	Read: Disabled																												
		Enabled	1	Read: Enabled																												

6.29.4.4 INTENCLR

Address offset: 0x308

Disable interrupt

Bit number	31 30 29 28 27 26 25 24 23 22 21 20 19 18 17 16 15 14 13 12 11 10 9 8 7 6 5 4 3 2 1 0																														
ID	A																														
Reset	0x00000000																														
0 0																															
ID	Acce	Field	Value ID	Value	Description																										
A	RW	TIMEOUT			Write '1' to disable interrupt for event TIMEOUT																										
			Clear	1	Disable																										
			Disabled	0	Read: Disabled																										
			Enabled	1	Read: Enabled																										

6.29.4.5 RUNSTATUS

Address offset: 0x400

Run status

Bit number	31 30 29 28 27 26 25 24 23 22 21 20 19 18 17 16 15 14 13 12 11 10 9 8 7 6 5 4 3 2 1 0																														
ID	A																														
Reset	0x00000000																														
0 0																															
ID	Acce	Field	Value ID	Value	Description																										
A	R	RUNSTATUS			Indicates whether or not the watchdog is running																										
			NotRunning	0	Watchdog not running																										
			Running	1	Watchdog is running																										

6.29.4.6 REQSTATUS

Address offset: 0x404

Request status

Bit number	31 30 29 28 27 26 25 24 23 22 21 20 19 18 17 16 15 14 13 12 11 10 9 8 7 6 5 4 3 2 1 0																														
ID																												H G F E D C B A			
Reset	0x00000001																														
0 1																															
ID	Acce	Field	Value ID	Value	Description																										
A-H	R	RR[i] (i=0..7)			Request status for RR[i] register																										
			DisabledOrRequested	0	RR[i] register is not enabled, or are already requesting reload																										
			EnabledAndUnrequested	1	RR[i] register is enabled, and are not yet requesting reload																										

6.29.4.7 CRV

Address offset: 0x504

Counter reload value

Bit number	31	30	29	28	27	26	25	24	23	22	21	20	19	18	17	16	15	14	13	12	11	10	9	8	7	6	5	4	3	2	1	0
ID	A	A	A	A	A	A	A	A	A	A	A	A	A	A	A	A	A	A	A	A	A	A	A	A	A	A	A	A	A	A	A	A
Reset 0xFFFFFFFF	1	1	1	1	1	1	1	1	1	1	1	1	1	1	1	1	1	1	1	1	1	1	1	1	1	1	1	1	1	1	1	
ID	Acce Field	Value ID	Value	Description																												
A	RW	CRV	[0x0000000F..0xFFFFFFFF]	Counter reload value in number of cycles of the 32.768 kHz clock																												

6.29.4.8 RREN

Address offset: 0x508

Enable register for reload request registers

Bit number	31	30	29	28	27	26	25	24	23	22	21	20	19	18	17	16	15	14	13	12	11	10	9	8	7	6	5	4	3	2	1	0
ID																																
Reset 0x00000001	0	0	0	0	0	0	0	0	0	0	0	0	0	0	0	0	0	0	0	0	0	0	0	0	0	0	0	0	0	0	0	
ID	Acce Field	Value ID	Value	Description																												
A-H	RW	RR[i] (i=0..7)		Enable or disable RR[i] register																												
		Disabled	0	Disable RR[i] register																												
		Enabled	1	Enable RR[i] register																												

6.29.4.9 CONFIG

Address offset: 0x50C

Configuration register

Bit number	31	30	29	28	27	26	25	24	23	22	21	20	19	18	17	16	15	14	13	12	11	10	9	8	7	6	5	4	3	2	1	0
ID																																
Reset 0x00000001	0	0	0	0	0	0	0	0	0	0	0	0	0	0	0	0	0	0	0	0	0	0	0	0	0	0	0	0	0	0	0	
ID	Acce Field	Value ID	Value	Description																												
A	RW	SLEEP		Configure the watchdog to either be paused, or kept running, while the CPU is sleeping																												
		Pause	0	Pause watchdog while the CPU is sleeping																												
		Run	1	Keep the watchdog running while the CPU is sleeping																												
C	RW	HALT		Configure the watchdog to either be paused, or kept running, while the CPU is halted by the debugger																												
		Pause	0	Pause watchdog while the CPU is halted by the debugger																												
		Run	1	Keep the watchdog running while the CPU is halted by the debugger																												

6.29.4.10 RR[n] (n=0..7)

Address offset: 0x600 + (n × 0x4)

Reload request n

Bit number	31	30	29	28	27	26	25	24	23	22	21	20	19	18	17	16	15	14	13	12	11	10	9	8	7	6	5	4	3	2	1	0
ID	A	A	A	A	A	A	A	A	A	A	A	A	A	A	A	A	A	A	A	A	A	A	A	A	A	A	A	A	A	A	A	
Reset 0x00000000	0	0	0	0	0	0	0	0	0	0	0	0	0	0	0	0	0	0	0	0	0	0	0	0	0	0	0	0	0	0	0	
ID	Acce Field	Value ID	Value	Description																												
A	W	RR		Reload request register																												
		Reload	0x6E524635	Value to request a reload of the watchdog timer																												

6.29.5 Electrical specification

6.29.5.1 Watchdog Timer Electrical Specification

Symbol	Description	Min.	Typ.	Max.	Units
t_{WDT}	Time out interval	458 μ s		36 h	

7 Hardware and layout

7.1 Pin assignments

The pin assignment figures and tables describe the pinouts for the product variants of the chip. There are also recommendations for how the GPIO pins should be configured, in addition to any usage restrictions.

7.1.1 QFN48 pin assignments

The nRF52810 QFN48 pin assignment table and figure describe the pinouts for this variant of the chip.

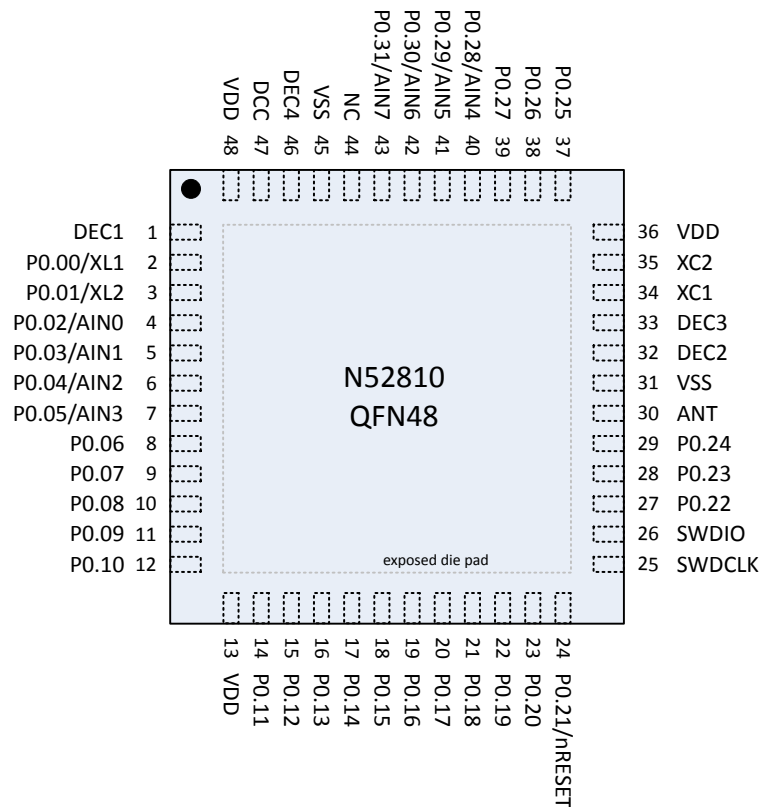

Figure 137: QFN48 pin assignments, top view

Pin	Name	Type	Description
1	DEC1	Power	0.9 V regulator digital supply decoupling
2	P0.00	Digital I/O	General purpose I/O
	XL1	Analog input	Connection for 32.768 kHz crystal (LFXO)

Pin	Name	Type	Description
3	P0.01	Digital I/O	General purpose I/O
	XL2	Analog input	Connection for 32.768 kHz crystal (LFXO)
4	P0.02	Digital I/O	General purpose I/O
	AIN0	Analog input	COMP input SAADC input
5	P0.03	Digital I/O	General purpose I/O
	AIN1	Analog input	COMP input SAADC input
6	P0.04	Digital I/O	General purpose I/O
	AIN2	Analog input	COMP input SAADC input
7	P0.05	Digital I/O	General purpose I/O
	AIN3	Analog input	COMP input SAADC input
8	P0.06	Digital I/O	General purpose I/O
9	P0.07	Digital I/O	General purpose I/O
10	P0.08	Digital I/O	General purpose I/O
11	P0.09	Digital I/O	General purpose I/O
12	P0.10	Digital I/O	General purpose I/O
13	VDD	Power	Power supply
14	P0.11	Digital I/O	General purpose I/O
15	P0.12	Digital I/O	General purpose I/O
16	P0.13	Digital I/O	General purpose I/O
17	P0.14	Digital I/O	General purpose I/O
18	P0.15	Digital I/O	General purpose I/O
19	P0.16	Digital I/O	General purpose I/O
20	P0.17	Digital I/O	General purpose I/O
21	P0.18	Digital I/O	General purpose I/O
22	P0.19	Digital I/O	General purpose I/O
23	P0.20	Digital I/O	General purpose I/O
24	P0.21	Digital I/O	General purpose I/O
	nRESET		Configurable as pin reset
25	SWDCLK	Digital input	Serial wire debug clock input for debug and programming
26	SWDIO	Digital I/O	Serial wire debug I/O for debug and programming
27	P0.22	Digital I/O	General purpose I/O
28	P0.23	Digital I/O	General purpose I/O
29	P0.24	Digital I/O	General purpose I/O
30	ANT	RF	Single-ended radio antenna connection
31	VSS	Power	Ground (radio supply)
32	DEC2	Power	1.3 V regulator supply decoupling (radio supply)
33	DEC3	Power	Power supply decoupling
34	XC1	Analog input	Connection for 32 MHz crystal
35	XC2	Analog input	Connection for 32 MHz crystal
36	VDD	Power	Power supply

Pin	Name	Type	Description
37	P0.25	Digital I/O	General purpose I/O
38	P0.26	Digital I/O	General purpose I/O
39	P0.27	Digital I/O	General purpose I/O
40	P0.28	Digital I/O	General purpose I/O
	AIN4	Analog input	COMP input SAADC input
41	P0.29	Digital I/O	General purpose I/O
	AIN5	Analog input	COMP input SAADC input
42	P0.30	Digital I/O	General purpose I/O
	AIN6	Analog input	COMP input SAADC input
43	P0.31	Digital I/O	General purpose I/O pin
	AIN7	Analog input	COMP input SAADC input
44	NC		No connect
			Leave unconnected
45	VSS	Power	Ground
46	DEC4	Power	1.3 V regulator supply decoupling
			Input from DC/DC regulator
			Output from 1.3 V LDO
47	DCC	Power	DC/DC regulator output
48	VDD	Power	Power supply
Die pad	VSS	Power	Ground pad

Exposed die pad must be connected to ground (VSS) for proper device operation.

Table 113: QFN48 pin assignments

7.1.2 QFN32 pin assignments

The nRF52810 QFN32 pin assignment table and figure describe the pinouts for this variant of the chip.

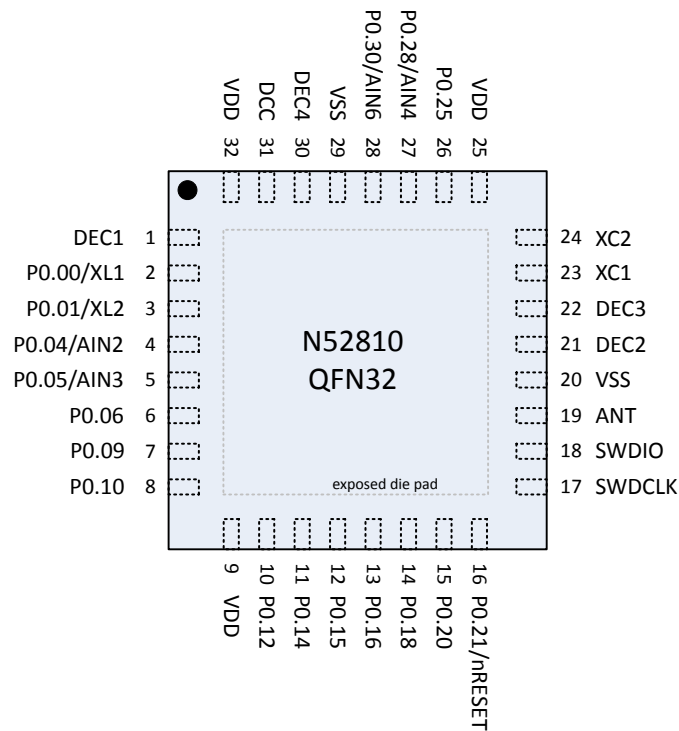

Figure 138: QFN32 pin assignments, top view

Pin	Name	Type	Description
1	DEC1	Power	0.9 V regulator digital supply decoupling
2	P0.00	Digital I/O	General purpose I/O
	XL1	Analog input	Connection for 32.768 kHz crystal (LFXO)
3	P0.01	Digital I/O	General purpose I/O
	XL2	Analog input	Connection for 32.768 kHz crystal (LFXO)
4	P0.04	Digital I/O	General purpose I/O
	AIN2	Analog input	COMP input SAADC input
5	P0.05	Digital I/O	General purpose I/O
	AIN3	Analog input	COMP input SAADC input
6	P0.06	Digital I/O	General purpose I/O
7	P0.09	Digital I/O	General purpose I/O
8	P0.10	Digital I/O	General purpose I/O
9	VDD	Power	Power supply
10	P0.12	Digital I/O	General purpose I/O
11	P0.14	Digital I/O	General purpose I/O
12	P0.15	Digital I/O	General purpose I/O

Pin	Name	Type	Description
13	P0.16	Digital I/O	General purpose I/O
14	P0.18	Digital I/O	General purpose I/O Single wire output
15	P0.20	Digital I/O	General purpose I/O
16	P0.21	Digital I/O	General purpose I/O nRESET Configurable as pin reset
17	SWDCLK	Digital input	Serial wire debug clock input for debug and programming
18	SWDIO	Digital I/O	Serial wire debug I/O for debug and programming
19	ANT	RF	Single-ended radio antenna connection
20	VSS	Power	Ground (radio supply)
21	DEC2	Power	1.3 V regulator supply decoupling (radio supply)
22	DEC3	Power	Power supply decoupling
23	XC1	Analog input	Connection for 32 MHz crystal
24	XC2	Analog input	Connection for 32 MHz crystal
25	VDD	Power	Power supply
26	P0.25	Digital I/O	General purpose I/O
27	P0.28	Digital I/O	General purpose I/O
	AIN4	Analog input	COMP input SAADC input
28	P0.30	Digital I/O	General purpose I/O
	AIN6	Analog input	COMP input SAADC input
29	VSS	Power	Ground
30	DEC4	Power	1.3 V regulator supply decoupling Input from DC/DC regulator Output from 1.3 V LDO
31	DCC	Power	DC/DC regulator output
32	VDD	Power	Power supply
Die pad	VSS	Power	Ground pad Exposed die pad must be connected to ground (VSS) for proper device operation.

Table 114: QFN32 pin assignments

7.1.3 WLCSP ball assignments

The nRF52810 ball assignment table and figure describe the assignments for this variant of the chip.

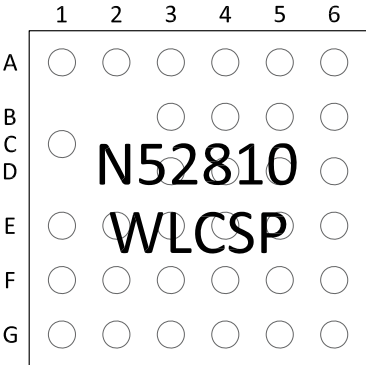

Figure 139: WLCSP ball assignments, top view

Balls not mentioned in the ball assignments table below are not connected (NC) and must be soldered to the PCB.

Pin	Name	Type	Description
A1	XC1	Analog input	Connection for 32 MHz crystal
A2	XC2	Analog input	Connection for 32 MHz crystal
A3	DEC2	Power	1.3 V regulator supply decoupling (radio supply)
A4	DEC4	Power	1.3 V analog supply. Input from DC/DC converter. Output from 1.3 V LDO.
A5	DCC	Power	DC/DC converter output (3.3 V PWM)
A6	VDD	Power	Power (battery) supply
B3	VSS	Power	Ground
B4	VSS	Power	Ground
B5	P0.00	Digital I/O	General purpose I/O
	XL1	Analog input	Connection for 32.768 kHz crystal (LFXO)
B6	DEC1	Power	0.9 V regulator digital supply decoupling
C1	VSS_PA	Power	Ground
D3	VSS	Power	Ground
D4	VSS	Power	Ground
D5	P0.01	Digital I/O	General purpose I/O
	XL2	Analog input	Connection for 32.768 kHz crystal (LFXO)
D6	P0.03	Digital I/O	General purpose I/O
	AIN1	Analog input	SAADC/COMP/LPCOMP input
E1	ANT	RF	Single-ended radio antenna connection
E2	P0.18	Digital I/O	General purpose I/O
E3	VSS	Power	Ground
E4	VSS	Power	Ground
E5	P0.04	Digital I/O	General purpose I/O
	AIN2	Analog input	SAADC/COMP/LPCOMP input
E6	P0.05	Digital I/O	General purpose I/O
	AIN3	Analog input	SAADC/COMP/LPCOMP input
F1	SWDIO	Digital I/O	Serial wire debug I/O for debug and programming
F2	P0.21	Digital I/O	General purpose I/O
	nRESET		Configurable as pin reset
F3	P0.17	Digital I/O	General purpose I/O
F4	P0.14	Digital I/O	General purpose I/O
F5	P0.11	Digital I/O	General purpose I/O
F6	P0.08	Digital I/O	General purpose I/O
G1	SWDCLK	Digital input	Serial wire debug clock input for debug and programming
G2	P0.20	Digital I/O	General purpose I/O
G3	P0.16	Digital I/O	General purpose I/O
G4	P0.15	Digital I/O	General purpose I/O
G5	P0.12	Digital I/O	General purpose I/O
G6	VDD	Power	Power (battery) supply

Table 115: WLCSP ball assignments

7.1.4 GPIO pins located near the radio

Radio performance parameters, such as sensitivity, may be affected by high frequency digital I/O with large sink/source current close to the radio power supply and antenna pins.

[GPIO recommended usage](#) on page 394 identifies some GPIO pins that have recommended usage guidelines for maximizing radio performance in an application.

GPIO	QFN48 pin	QFN32 pin	Recommended usage
P0.25	37	26	Low drive, low frequency I/O only.
P0.26	38		
P0.27	39		
P0.28	40	27	
P0.29	41		

Table 116: GPIO recommended usage

7.2 Mechanical specifications

The mechanical specifications for the packages show the dimensions in millimeters.

7.2.1 QFN48 6 x 6 mm package

Dimensions in millimeters for the nRF52810 QFN48 6 x 6 mm package.

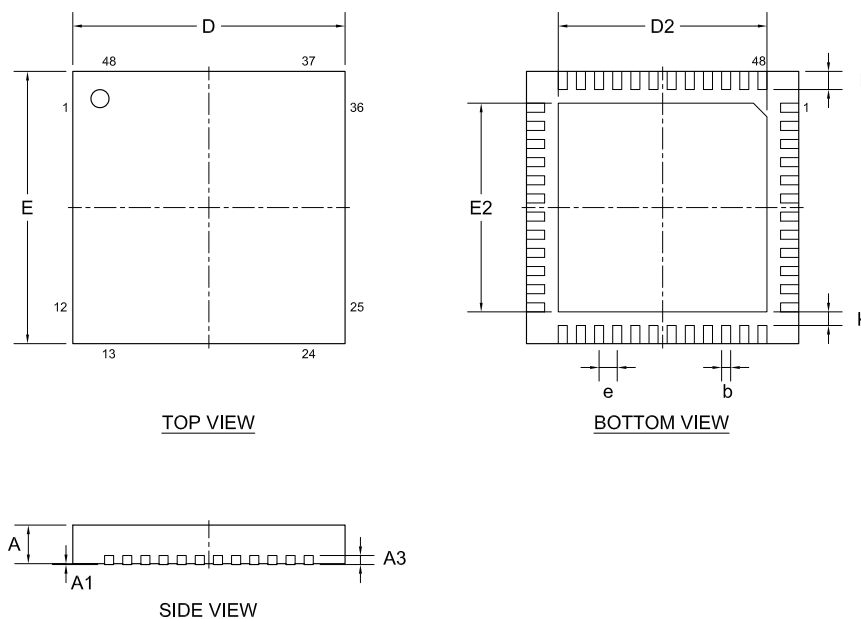

Figure 140: QFN48 6 x 6 mm package

	A	A1	A3	b	D, E	D2, E2	e	K	L
Min.	0.80	0.00		0.15		4.50		0.20	0.35
Nom.	0.85	0.04	0.20	0.20	6.00	4.60	0.40		0.40
Max.	0.90	0.05		0.25		4.70			0.45

Table 117: QFN48 dimensions in millimeters

7.2.2 QFN32 5 x 5 mm package

Dimensions in millimeters for the nRF52810 QFN32 5 x 5 mm package.

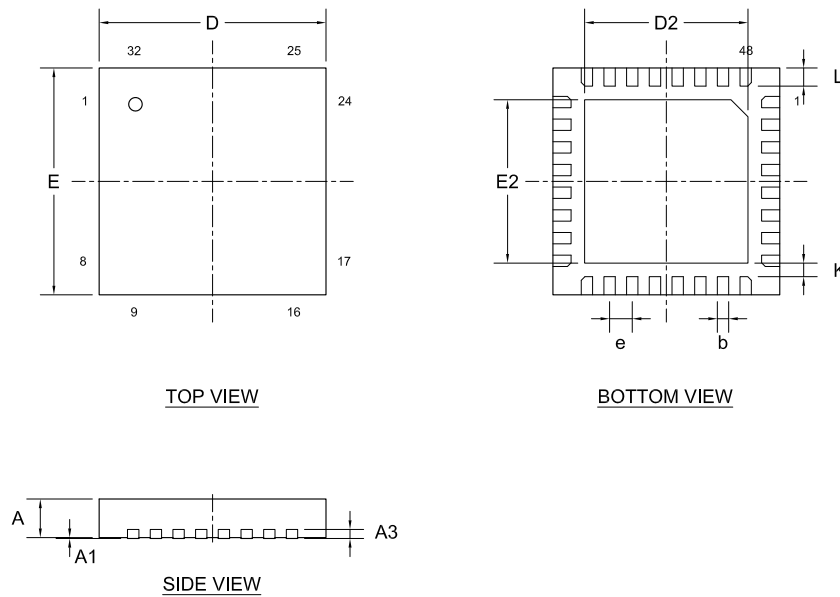

Figure 141: QFN32 5 x 5 mm package

	A	A1	A3	b	D, E	D2, E2	e	K	L
Min.	0.80	0.00		0.20		3.40		0.25	0.35
Nom.	0.85	0.04	0.20	0.25	5.00	3.50	0.50		0.40
Max.	0.90	0.05		0.30		3.60			0.45

Table 118: QFN32 dimensions in millimeters

7.2.3 WLCSP 2.482 x 2.464 mm package

Dimensions in millimeters for the nRF52810 WLCSP 2.482 x 2.464 mm package.

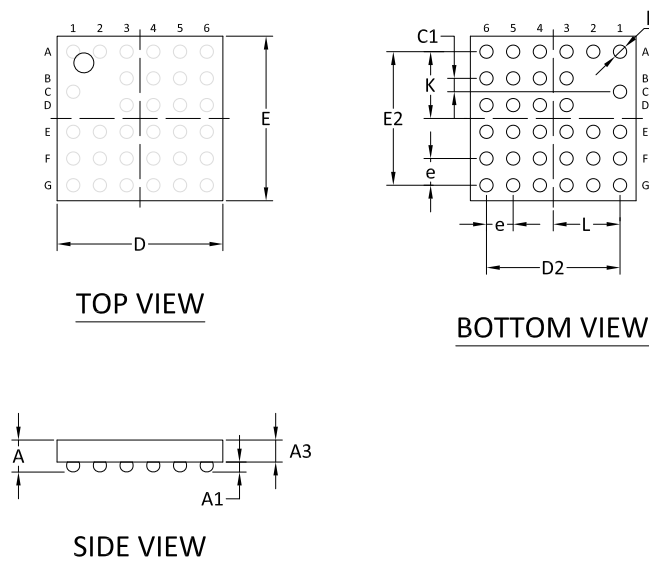

Figure 142: WLCSP 2.482 x 2.464 mm package

	A	A1	A3	b	C1	D	E	D2	E2	e	K	L
Min.	0.419	0.12	0.299	0.197								
Nom.	0.477		0.327		0.2	2.482	2.464	2.0	2.0	0.4	1.0	1.0
Max.	0.535	0.18	0.355	0.257								

Table 119: WLCSP dimensions in millimeters

7.3 Reference circuitry

To ensure good RF performance when designing PCBs, it is highly recommended to use the PCB layouts and component values provided by Nordic Semiconductor.

Documentation for the different package reference circuits, including Altium Designer files, PCB layout files, and PCB production files can be downloaded from [Reference layout nRF52 Series](#).

7.3.1 Schematic QFAA QFN48 with internal LDO regulator setup

In addition to the schematic, the bill of material (BOM) is also provided.

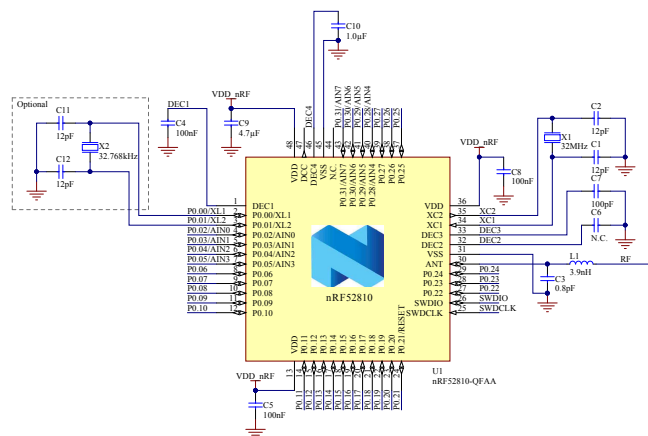

Figure 143: QFAA QFN48 with internal LDO regulator setup

Note: For PCB reference layouts, see [Reference layout nRF52 Series](#).

Designator	Value	Description	Footprint
C1, C2, C11, C12	12 pF	Capacitor, NPO, $\pm 2\%$	0402
C3	0.8 pF	Capacitor, NPO, $\pm 5\%$	0402
C4, C5, C8	100 nF	Capacitor, X7R, $\pm 10\%$	0402
C6	N.C.	Not mounted	0402
C7	100 pF	Capacitor, NPO, $\pm 5\%$	0402
C9	4.7 μ F	Capacitor, X5R, $\pm 10\%$	0603
C10	1.0 μ F	Capacitor, X7R, $\pm 10\%$	0603
L1	3.9 nH	High frequency chip inductor $\pm 5\%$	0402
U1	nRF52810-QFAA	Multi-protocol Bluetooth [®] low energy, ANT and 2.4 GHz proprietary system on chip	QFN-48
X1	32 MHz	XTAL SMD 2016, 32 MHz, CI = 8 pF, Total Tol: ± 40 ppm	XTAL_2016
X2	32.768 kHz	XTAL SMD 3215, 32.768 kHz, CI = 9 pF, Total Tol: ± 20 ppm	XTAL_3215

Table 120: Bill of material for QFAA QFN48 with internal LDO regulator setup

7.3.2 Schematic QFAA QFN48 with DC/DC regulator setup

In addition to the schematic, the bill of material (BOM) is also provided.

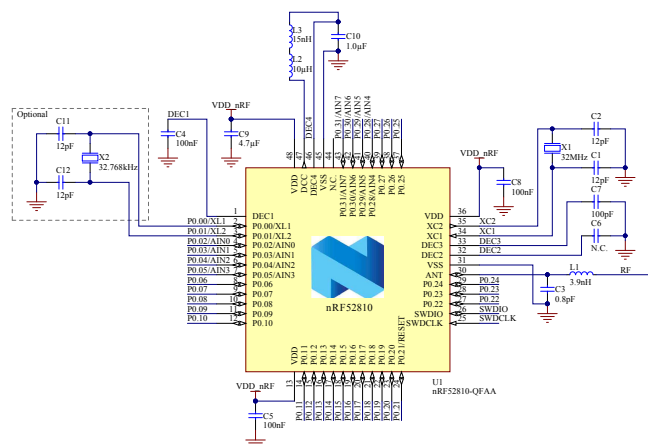

Figure 144: QFAA QFN48 with DC/DC regulator setup

Note: For PCB reference layouts, see [Reference layout nRF52 Series](#).

Note: For PCB reference layouts, see [Reference layout nRF52 Series](#).

Designator	Value	Description	Footprint
C1, C2, C11, C12	12 pF	Capacitor, NP0, $\pm 2\%$	0402
C3	0.8 pF	Capacitor, NP0, $\pm 5\%$	0402
C4, C5, C8	100 nF	Capacitor, X7R, $\pm 10\%$	0402
C6	N.C.	Not mounted	0402
C7	100 pF	Capacitor, NP0, $\pm 5\%$	0402
C9	4.7 μ F	Capacitor, X5R, $\pm 10\%$	0603
C10	1.0 μ F	Capacitor, X7R, $\pm 10\%$	0603
L1	3.9 nH	High frequency chip inductor $\pm 5\%$	0402
L2	10 μ H	Chip inductor, IDC, min = 50 mA, $\pm 20\%$	0603
L3	15 nH	High frequency chip inductor $\pm 10\%$	0402
U1	nRF52810-QCAA	Multi-protocol Bluetooth [®] low energy, ANT and 2.4 GHz proprietary system on chip	QFN-32
X1	32 MHz	XTAL SMD 2016, 32 MHz, Cl = 8 pF, Total Tol: ± 40 ppm	XTAL_2016
X2	32.768 kHz	XTAL SMD 3215, 32.768 kHz, Cl = 9 pF, Total Tol: ± 20 ppm	XTAL_3215

Table 123: Bill of material for QCAA QFN32 with DC/DC regulator setup

7.3.5 Schematic CAAA WLCSP with internal LDO regulator setup

In addition to the schematic, the bill of material (BOM) is also provided.

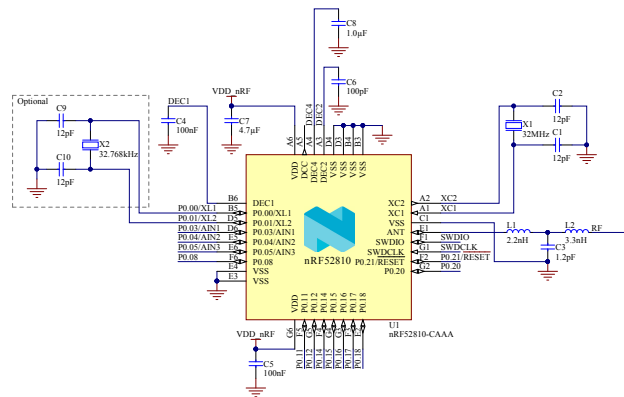

Figure 147: CAAA WLCSP with internal LDO regulator setup

Note: For PCB reference layouts, see [Reference layout nRF52 Series](#).

Designator	Value	Description	Footprint
C1, C2, C9, C10	12 pF	Capacitor, NPO, $\pm 2\%$	0201
C3	1.2 pF	Capacitor, NPO, $\pm 5\%$	0201
C4, C5	100 nF	Capacitor, X5R, $\pm 10\%$	0201
C6	100 pF	Capacitor, NPO, $\pm 2\%$	0201
C7	4.7 μ F	Capacitor, X5R, $\pm 10\%$	0603
C8	1.0 μ F	Capacitor, X5R, $\pm 5\%$	0402
L1	2.2 nH	High frequency chip inductor $\pm 5\%$	0201
L2	3.3 nH	High frequency chip inductor $\pm 5\%$	0201
U1	nRF52810-CAAA	Multi-protocol Bluetooth [®] low energy, ANT and 2.4 GHz proprietary system on chip	WLCSP-33
X1	32 MHz	XTAL SMD 2016, 32 MHz, CI = 8 pF, Total Tol: ± 40 ppm	XTAL_2016
X2	32.768 kHz	XTAL SMD 2012, 32.768 kHz, CI = 9 pF, Total Tol: ± 50 ppm	XTAL_2012

Table 124: Bill of material for CAAA WLCSP with internal LDO regulator setup

7.3.6 Schematic CAAA WLCSP with DC/DC regulator setup

In addition to the schematic, the bill of material (BOM) is also provided.

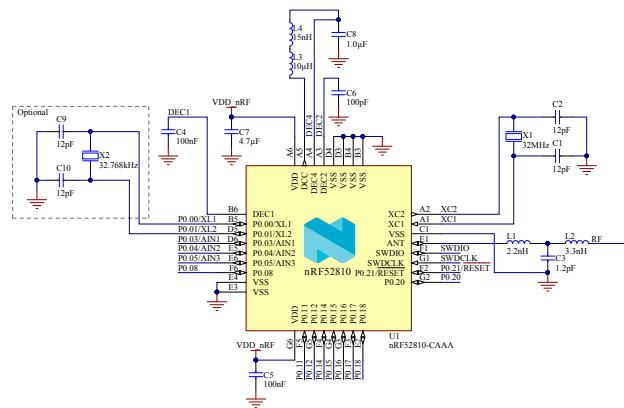

Figure 148: CAAA WLCSF with DC/DC regulator setup

Note: For PCB reference layouts, see [Reference layout nRF52 Series](#).

Designator	Value	Description	Footprint
C1, C2, C9, C10	12 pF	Capacitor, NPO, $\pm 2\%$	0201
C3	1.2 pF	Capacitor, NPO, $\pm 5\%$	0201
C4, C5	100 nF	Capacitor, X5R, $\pm 10\%$	0201
C6	100 pF	Capacitor, NPO, $\pm 2\%$	0201
C7	4.7 μ F	Capacitor, X5R, $\pm 10\%$	0603
C8	1.0 μ F	Capacitor, X5R, $\pm 5\%$	0402
L1	2.2 nH	High frequency chip inductor $\pm 5\%$	0201
L2	3.3 nH	High frequency chip inductor $\pm 5\%$	0201
L3	10 μ H	Chip inductor, IDC, min = 50 mA, $\pm 20\%$	0603
L4	15 nH	High frequency chip inductor $\pm 10\%$	0402
U1	nRF52810-CAAA	Multi-protocol Bluetooth [®] low energy, ANT and 2.4 GHz proprietary system on chip	WLCSF-33
X1	32 MHz	XTAL SMD 2016, 32 MHz, CI = 8 pF, Total Tol: ± 40 ppm	XTAL_2016
X2	32.768 kHz	XTAL SMD 2012, 32.768 kHz, CI = 9 pF, Total Tol: ± 50 ppm	XTAL_2012

Table 125: Bill of material for CAAA WLCSF with DC/DC regulator setup

7.3.7 Schematic CAAA WLCSP with two layers

In addition to the schematic, the bill of material (BOM) is also provided.

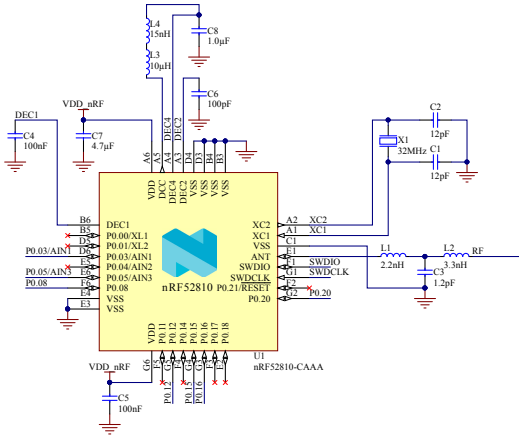

Figure 149: CAAA WLCSP 2-layer setup

Note: For PCB reference layouts, see Reference layout nRF52 Series.

Designator	Value	Description	Footprint
C1, C2	12 pF	Capacitor, NPO, $\pm 2\%$	0201
C3	1.2 pF	Capacitor, NPO, $\pm 5\%$	0201
C4, C5	100 nF	Capacitor, X5R, $\pm 10\%$	0201
C6	100 pF	Capacitor, NPO, $\pm 2\%$	0201
C7	4.7 μ F	Capacitor, X5R, $\pm 10\%$	0603
C8	1.0 μ F	Capacitor, X5R, $\pm 5\%$	0402
L1	2.2 nH	High frequency chip inductor $\pm 5\%$	0201
L2	3.3 nH	High frequency chip inductor $\pm 5\%$	0201
L3	10 μ H	Chip inductor, IDC, min = 50 mA, $\pm 20\%$	0603
L4	15 nH	High frequency chip inductor $\pm 10\%$	0402
U1	nRF52810- CAA	Multi-protocol Bluetooth [®] low energy, ANT and 2.4 GHz proprietary system on chip	WLCSP-33
X1	32 MHz	XTAL SMD 2016, 32 MHz, Cl = 8 pF, Total Tol: ± 40 ppm	XTAL_2016

Table 126: Bill of material for CAAA WLCSP 2-layer setup

7.3.8 PCB guidelines

A well designed PCB is necessary to achieve good RF performance. Poor layout can lead to loss in performance or functionality.

A qualified RF layout for the IC and its surrounding components, including matching networks, can be downloaded from [Reference layout nRF52 Series](#).

To ensure optimal performance it is essential that you follow the schematics and layout references closely. Especially in the case of the antenna matching circuitry (components between device pin ANT and the antenna), any changes to the layout can change the behavior, resulting in degradation of RF performance or a need to change component values. All reference circuits are designed for use with a 50 Ω single-ended antenna.

A PCB with a minimum of two layers, including a ground plane, is recommended for optimal performance. On PCBs with more than two layers, put a keep-out area on the inner layers directly below the antenna matching circuitry (components between device pin ANT and the antenna) to reduce the stray capacitances that influence RF performance.

A matching network is needed between the RF pin ANT and the antenna, to match the antenna impedance (normally 50 Ω) to the optimum RF load impedance for the chip. For optimum performance, the impedance for the matching network should be set as described in the recommended package reference circuitry in [Reference circuitry](#) on page 396 above.

The DC supply voltage should be decoupled as close as possible to the VDD pins with high performance RF capacitors. See the schematics for recommended decoupling capacitor values. The supply voltage for the chip should be filtered and routed separately from the supply voltages of any digital circuitry.

Long power supply lines on the PCB should be avoided. All device grounds, VDD connections, and VDD bypass capacitors must be connected as close as possible to the IC. For a PCB with a topside RF ground plane, the VSS pins should be connected directly to the ground plane. For a PCB with a bottom ground plane, the best technique is to have via holes as close as possible to the VSS pads. A minimum of one via hole should be used for each VSS pin.

Fast switching digital signals should not be routed close to the crystal or the power supply lines. Capacitive loading of fast switching digital output lines should be minimized in order to avoid radio interference.

7.3.9 PCB layout example

The PCB layout shown as the example is a reference layout for the QFN48 package with internal LDO setup.

Important: Pay attention to how the capacitor C3 is grounded. It is not directly connected to the ground plane, but grounded via VSS pin 31. This is done to create additional filtering of harmonic components.

For all available reference layouts, see [Reference layout nRF52 Series](#).

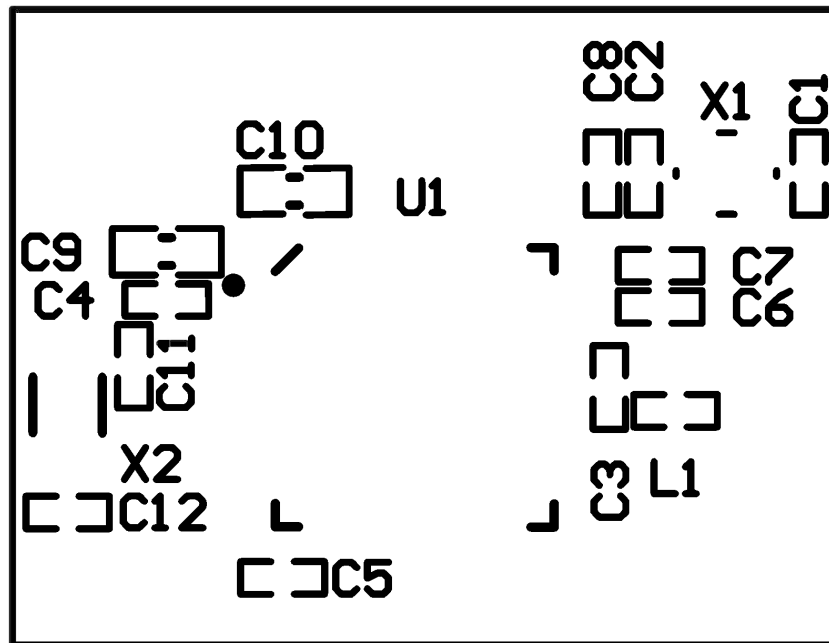

Figure 150: Top silk layer

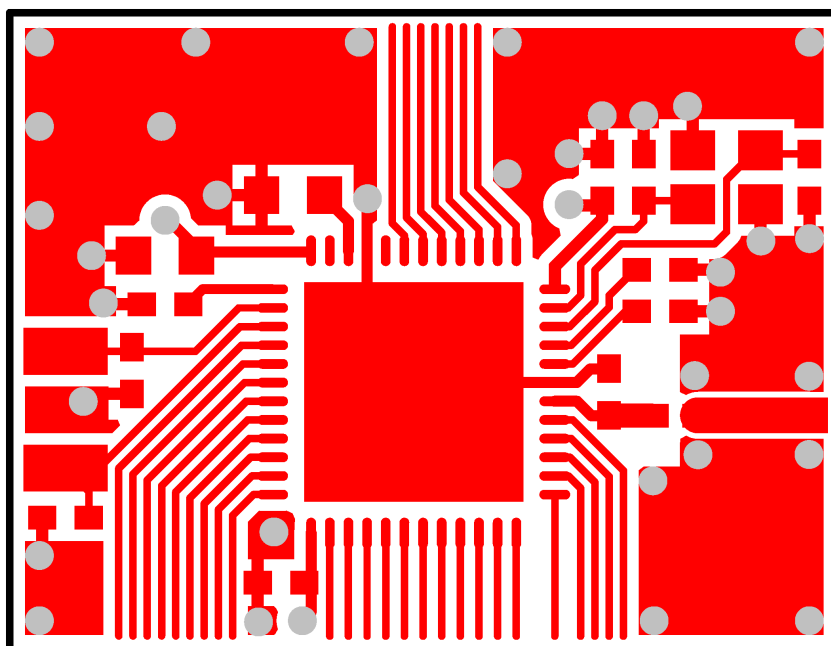

Figure 151: Top layer

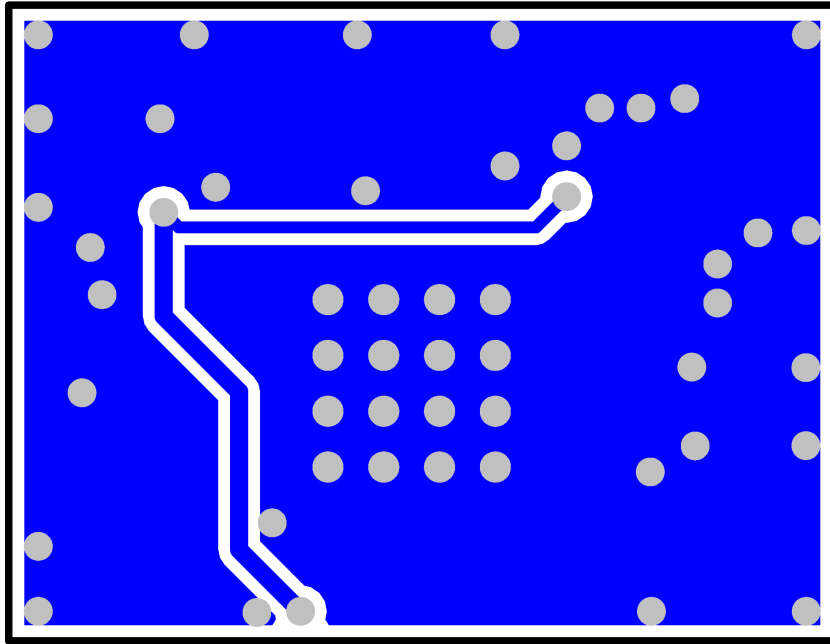

Figure 152: Bottom layer

Important: No components in bottom layer.

8 Recommended operating conditions

The operating conditions are the physical parameters that the chip can operate within.

Symbol	Parameter	Notes	Min.	Nom.	Max.	Units
VDD	Supply voltage, independent of DCDC enable		1.7	3.0	3.6	V
t _{R_VDD}	Supply rise time (0 V to 1.7 V)				60	ms
TA	Operating temperature		-40	25	85	°C

Table 127: Recommended operating conditions

Important: The on-chip power-on reset circuitry may not function properly for rise times longer than the specified maximum.

8.1 WLCSP light sensitivity

WLCSP package variants are sensitive to visible and near infrared light, which means that a final product design must shield the chip properly.

For the CAAA package variant, the marking side is covered with a light absorbing film, while the side edges of the chip and the ball side must be protected by coating or other means.

9 Absolute maximum ratings

Maximum ratings are the extreme limits to which the chip can be exposed for a limited amount of time without permanently damaging it. Exposure to absolute maximum ratings for prolonged periods of time may affect the reliability of the device.

	Note	Min.	Max.	Unit
Supply voltages				
VDD		-0.3	+3.9	V
VSS			0	V
I/O pin voltage				
$V_{I/O}, VDD \leq 3.6\text{ V}$		-0.3	$VDD + 0.3$	V
$V_{I/O}, VDD > 3.6\text{ V}$		-0.3	3.9	V
Radio				
RF input level			10	dBm
Environmental QFN package				
Storage temperature		-40	+125	°C
MSL	Moisture Sensitivity Level		2	
ESD HBM	Human Body Model		4	kV
ESD HBM Class	Human Body Model Class		3A	
ESD CDM	Charged Device Model		1	kV
Environmental WLCSP 2.482 x 2.464 mm package				
Storage temperature		-40	+125	°C
MSL	Moisture Sensitivity Level		1	
ESD HBM	Human Body Model		2	kV
ESD HBM Class	Human Body Model Class		2	
ESD CDM	Charged Device Model		1	kV
Flash memory				
Endurance		10 000		Write/erase cycles
Retention		10 years at 40°C		

Table 128: Absolute maximum ratings



10 Ordering information

This chapter contains information on IC marking, ordering codes, and container sizes.

10.1 IC marking

The IC package is marked like described below.

N	5	2	8	1	0
<P>	P>	<V>	V>	<H>	<P>
<Y>	Y>	<W>	W>	<L>	L>

Figure 153: Package marking

10.2 Box labels

Here are the box labels used for the IC.

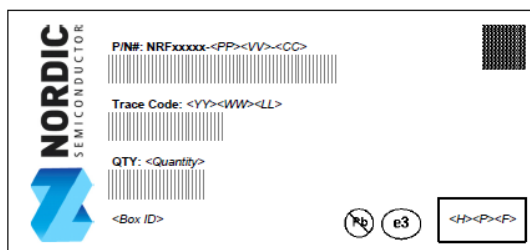

Figure 154: Inner box label

Figure 155: Outer box label

10.3 Order code

Here are the nRF52810 order codes and definitions.

n	R	F	5	2	8	1	0	-	<P	P>	<V	V>	-	<C	C>
---	---	---	---	---	---	---	---	---	----	----	----	----	---	----	----

Figure 156: Order code

Abbreviation	Definition and implemented codes
N52/nRF52	nRF52 Series product
810	Part code
<PP>	Package variant code
<VV>	Function variant code
<H><P><F>	Build code H - Hardware version code P - Production configuration code (production site, etc.) F - Firmware version code (only visible on shipping container label)
<YY><WW><LL>	Tracking code YY - Year code WW - Assembly week number LL - Wafer lot code
<CC>	Container code

Table 129: Abbreviations

10.4 Code ranges and values

Defined here are the nRF52810 code ranges and values.

<PP>	Package	Size (mm)	Pin/Ball count	Pitch (mm)
QF	QFN	6 x 6	48	0.4
QC	QFN	5 x 5	32	0.5
CA	WLCSP	2.482 x 2.464	33	0.4

Table 130: Package variant codes

<VV>	Flash (kB)	RAM (kB)
AA	192	24

Table 131: Function variant codes

<H>	Description
[A . . Z]	Hardware version/revision identifier (incremental)

Table 132: Hardware version codes

<P>	Description
[0 . . 9]	Production device identifier (incremental)
[A . . Z]	Engineering device identifier (incremental)

Table 133: Production configuration codes

<F>	Description
[A . . N, P . . Z]	Version of preprogrammed firmware
[0]	Delivered without preprogrammed firmware

Table 134: Production version codes

<YY>	Description
[15 . . 99]	Production year: 2015 to 2099

Table 135: Year codes

<WW>	Description
[1 . . 52]	Week of production

Table 136: Week codes

<LL>	Description
[AA . . ZZ]	Wafer production lot identifier

Table 137: Lot codes

<CC>	Description
R7	7" Reel
R	13" Reel
T	Tray

Table 138: Container codes

10.5 Product options

Defined here are the nRF52810 product options.

Order code	MOQ (minimum ordering quantity)	Comment
nRF52810-QFAA-R7	1000	Availability to be announced.
nRF52810-QFAA-R	3000	
nRF52810-QFAA-T	490	
nRF52810-QCAA-R7	1500	
nRF52810-QCAA-R	4000	
nRF52810-QCAA-T	490	
nRF52810-CAAA-R7	1500	
nRF52810-CAAA-R	7000	

Table 139: nRF IC order codes

Order code	Description
nRF52-DK	nRF52832 development kit with tools to support nRF52810 development.

Table 140: Development tools order code

11 Legal notices

By using this documentation you agree to our terms and conditions of use. Nordic Semiconductor ASA may change these terms and conditions at any time without notice.

11.1 Liability disclaimer

Nordic Semiconductor ASA reserves the right to make changes without further notice to the product to improve reliability, function or design. Nordic Semiconductor ASA does not assume any liability arising out of the application or use of any product or circuits described herein.

Information in this document is believed to be accurate and reliable. Nordic Semiconductor ASA does not give any representations or warranties, expressed or implied, as to the accuracy or completeness of such information and shall have no liability for the consequences of use of such information. If there are any discrepancies, ambiguities or conflicts in Nordic Semiconductor's documentation, the Product Specification prevails.

Nordic Semiconductor ASA reserves the right to make corrections, enhancements, and other changes to this document without notice.

11.2 Life support applications

Nordic Semiconductor ASA products are not designed for use in life support appliances, devices, or systems where malfunction of these products can reasonably be expected to result in personal injury.

Nordic Semiconductor ASA customers using or selling these products for use in such applications do so at their own risk and agree to fully indemnify Nordic Semiconductor ASA for any damages resulting from such improper use or sale.

11.3 RoHS and REACH statement

Nordic Semiconductor products meet the requirements of Directive 2002/95/EC of the European Parliament and of the Council on the Restriction of Hazardous Substances (RoHS) and the requirements of the REACH regulation (EC 1907/2006) on Registration, Evaluation, Authorization and Restriction of Chemicals.

The SVHC (Substances of Very High Concern) candidate list is continually being updated. Complete hazardous substance reports, material composition reports and latest version of Nordic Semiconductor's REACH statement can be found on our website <http://www.nordicsemi.com>.

11.4 Trademarks

All trademarks, service marks, trade names, product names and logos appearing in this documentation are the property of their respective owners.

11.5 Copyright notice

© 2018 Nordic Semiconductor ASA. All rights are reserved. Reproduction in whole or in part is prohibited without the prior written permission of the copyright holder.

**COMPANY WITH
QUALITY SYSTEM
CERTIFIED BY DNV GL
= ISO 9001 =**

Looking for pricing, stock, or lifecycle information?

Click below to explore more details on WIN SOURCE:

- ⊖ [View NRF52810-QCAA-R7 on WIN SOURCE](#)
- ⊖ [Nordic Semiconductors Information](#)

Optimize Your Supply Chain with WIN SOURCE Solutions

- ✓ Global Sourcing Solution
- ✓ Obsolete Management
- ✓ Cost Control Management
- ✓ Shortage Management
- ✓ Alternative Solution
- ✓ Excess Inventory Management