



**THE DATASHEET OF  
EVAL-ADM2487EEB5Z**



## Evaluation Boards for the ADM2482E and ADM2487E Isolated RS-485 Transceivers

### FEATURES

- Easy evaluation of the [ADM2482E/ADM2487E](#)
- Isolated ground plane layout
- Configurable as full duplex or half duplex
- Evaluation of the [ADM2482E](#) at 16 Mbps
- Evaluation of the [ADM2487E](#) at 500 kbps

### ADM2482E/ADM2487E APPLICATIONS

- Isolated RS-485/RS-422 interfaces
- Process field bus (PROFIBUS) networks
- Industrial field networks
- Multipoint data transmission systems

### EVALUATION KIT CONTENTS

- EVAL-ADM2482EEB3Z, EVAL-ADM2487EEB3Z,  
EVAL-ADM2482EEB5Z, or EVAL-ADM2487EEB5Z

### GENERAL DESCRIPTION

The [ADM2482E/ADM2487E](#) evaluation boards allow the [ADM2482E/ADM2487E](#) isolated RS-485 transceivers to be quickly and easily evaluated. The evaluation board allows all of the input and output functions to be exercised without the need for external components.

The [ADM2482E/ADM2487E](#) feature an integrated transformer driver that outputs a pair of square waves to an external transformer to provide isolated power. When the [ADM2482E/ADM2487E](#) are powered by 3.3 V on the logic side ( $V_{DD1}$ ), a transformer, U3, is required with a turns ratio of 1:1.5 (DA2303-AL). This ensures that there is enough headroom for the [ADP3330](#) LDO to output a regulated 3.3 V output (EVAL-ADM2482EEB3Z and EVAL-ADM2487EEB3Z).

When the [ADM2482E/ADM2487E](#) are powered by 5 V on the logic side, a transformer, U3, is required with a turns ratio of 1:1 (GA3157-AL) to give a 5 V input for the [ADP3330](#), which regulates an output of 3.3 V output (EVAL-ADM2482EEB5Z and EVAL-ADM2487EEB5Z).

### FUNCTIONAL BLOCK DIAGRAM

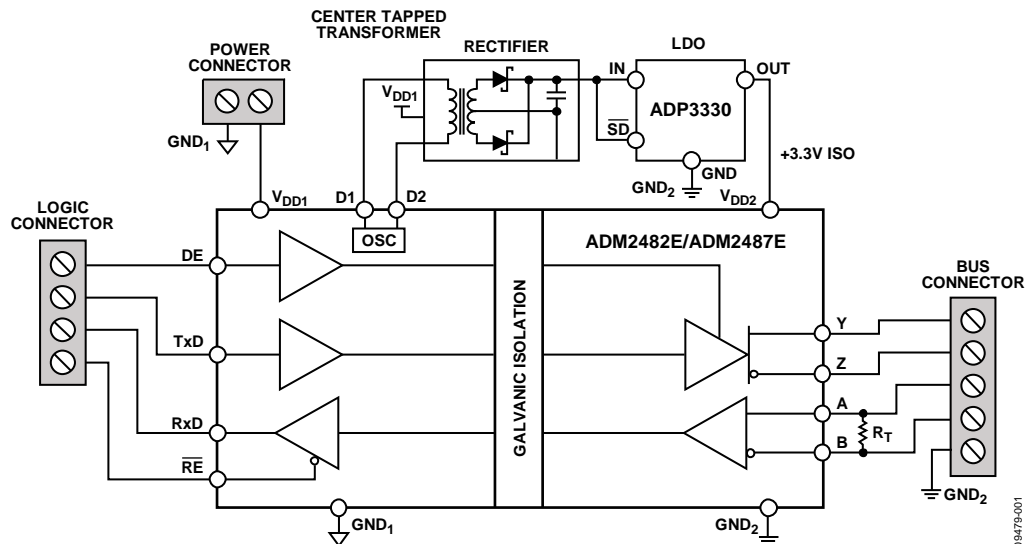

Figure 1.

084774-001

**TABLE OF CONTENTS**

Features ..... 1  
 ADM2482E/ADM2487E Applications ..... 1  
 Evaluation Kit Contents..... 1  
 General Description ..... 1  
 Functional Block Diagram ..... 1  
 Revision History ..... 2  
 Evaluation Board Configurations..... 3  
     3.3 V Evaluation Board..... 3  
     5 V Evaluation Board ..... 3

Full Duplex, Bus Biasing And Termination Resistors on Receiver Input .....3  
 Full Duplex, Bus Biasing And Termination Resistors on Receiver and Transmitter .....3  
 Half Duplex with Bus Biasing and Termination .....3  
 Powering Up the Bus Side .....3  
 Evaluation Board Schematic and Artwork.....5  
 Ordering Information.....9  
     Bill of Materials.....9  
 Related Links.....9

**REVISION HISTORY**

**8/11—Rev. 0 to Rev. A**

Changed EVAL2482EEB5Z to EVAL-ADM2482EEB5Z, EVAL2487EEB5Z to EVAL-ADM2487EEB5Z, and ADP1710 to ADP3330 Throughout ..... 1  
 Change to Figure 1 ..... 1  
 Changes to Evaluation Board Configurations Section ..... 3  
 Changes to Table 1 ..... 4  
 Change to Figure 2 ..... 5  
 Changes to Figure 3 ..... 6  
 Changes to Figure 4 ..... 7  
 Changes to Figure 5 ..... 8  
 Changes to Table 2 and Related Links Section ..... 9

**11/10—Revision 0: Initial Version**

## EVALUATION BOARD CONFIGURATIONS

### 3.3 V EVALUATION BOARD

The EVAL-ADM2482EEB3Z and EVAL-ADM2487EEB3Z are shipped in a 3.3 V full-duplex configuration without any bus biasing resistors inserted by default. The jumper settings are shown in Table 1. The transformer fitted as U3 for the 3.3 V version of the evaluation board is the DA2303-AL with a turns ratio of 1:1.5. The DA2303-AL allows enough headroom for the [ADP3330](#) LDO to output a regulated 3.3 V output.

### 5 V EVALUATION BOARD

The EVAL-ADM2482EEB5Z and EVAL-ADM2487EEB5Z are shipped in a 5 V full-duplex configuration without any bus biasing resistors inserted by default. The jumper settings are shown in Table 1. The transformer fitted as U3 for the 5 V version of the evaluation board is the GA3157-AL with a turns ratio of 1:1. The GA3157-AL is required to give a 5 V input to the [ADP3330](#) LDO, which regulates an output of 3.3 V.

### FULL DUPLEX, BUS BIASING AND TERMINATION RESISTORS ON RECEIVER INPUT

Bus biasing resistors can be fitted on the receiver input by inserting resistors R3 and R4. Jumpers LK11 and LK13 must be inserted for the bus biasing resistors to be active. All jumper combinations are shown in Table 1.

A termination resistor can be fitted on the receiver input by inserting RT. The value of the termination resistor should be equal to the characteristic impedance of the cable used. To activate the termination resistor, Jumper LK12 must be inserted.

### FULL DUPLEX, BUS BIASING AND TERMINATION RESISTORS ON RECEIVER AND TRANSMITTER

Bus biasing resistors can be fitted on the transmitter output as well as on the receiver input. Resistors R3, R4, R2, and R11 and

Jumpers LK11, LK13, LK7, and LK9 must be inserted for this configuration.

A termination resistor can also be fitted on the transmitter output by inserting RT1. The value of the termination resistor should be equal to the characteristic impedance of the cable used. To activate the termination resistor, Jumper LK10 must be inserted.

### HALF DUPLEX WITH BUS BIASING AND TERMINATION

To configure the evaluation board as half duplex, Receiver Input Pin A must be connected to Transmitter Output Pin Y and Receiver Input Pin B must be connected to Transmitter Output Pin Z. This is accomplished by inserting Jumper LK15 and Jumper LK16.

In this configuration if biasing resistors are inserted, only the resistors on the receiver input, or on the transmitter output should be selected. This is achieved by either inserting resistors R3 and R4 and jumpers LK11 and LK13 (leaving LK7 and LK9 open), or by inserting resistors R2 and R11 and jumpers LK7 and LK9 (leaving LK11 and LK13 open).

Similarly only the termination resistor on the receiver input or on the transmitter output should be selected (e.g. LK12 inserted, LK10 open).

### POWERING UP THE BUS SIDE

The bus side can be powered using either the regulator built into the board or by using an external power source. Jumper LK1 allows the user to select between these two methods. By inserting Jumper LK1 into Position A, the board can be powered using an external power source. Inserting Jumper LK1 into Position B selects the built-in regulator to supply the bus side.

**Table 1. Board Configurations and Jumper Settings**

<b>Configuration</b>	<b>Jumpers Fitted</b>	<b>Jumpers Open</b>
Full Duplex Configuration		LK 15, LK16
Half-Duplex Configuration (A Connected to Y, B Connected to Z)	LK15, LK16	
No Biasing Resistors		LK7, LK9, LK11, LK13
Bus Biasing Resistors on A/B only	LK11, LK13	LK7, LK9
Bus Biasing Resistors on Y/Z only	LK7, LK9	LK11, LK13
Bus Biasing Resistors on A/B and Y/Z (Full Duplex)	LK7, LK9, LK11, LK13	LK 15, LK16
No Termination Resistors		LK10, LK12
Termination Resistor on A/B only	LK12	LK10
Termination Resistor on Y/Z only	LK10	LK12
Termination Resistors on A/B and Y/Z (Full Duplex)	LK10, LK12	LK 15, LK16
Powering the Bus Side Using the Regulator on the Board	LK1 (Position B)	LK1 (Position A)
Powering the Bus Side Using an External Power Supply	LK1 (Position A)	LK1 (Position B)
Using the Transformer on the Board	LK2 (Position A) LK3 (Position A)	LK2 (Position C) LK3 (Position C)
Using the SMA Connector for Rx D	LK8 (Position A)	LK8 (Position B)
Using the Screw Terminal for Rx D	LK8 (Position B)	LK8 (Position A)
Using the SMA Connector for Tx D	LK5 (Position B)	LK5 (Position A)
Using the Screw Terminal for Tx D	LK5 (Position A)	LK5 (Position B)
$\overline{RE}$ High	LK4 (Position A)	
$\overline{RE}$ Low	LK4 (Position B)	
Using the Screw Terminal for $\overline{RE}$	LK4 (Position C)	
DE High	LK6 (Position A)	
DE Low	LK6 (Position B)	
Using the Screw Terminal for DE	LK6 (Position C)	
Tie $\overline{RE}$ and DE Together (Note Only One Jumper Can Be Inserted, Either LK4 or LK6)	LK14 and (LK4 or LK6)	LK4 or LK6

# EVALUATION BOARD SCHEMATIC AND ARTWORK

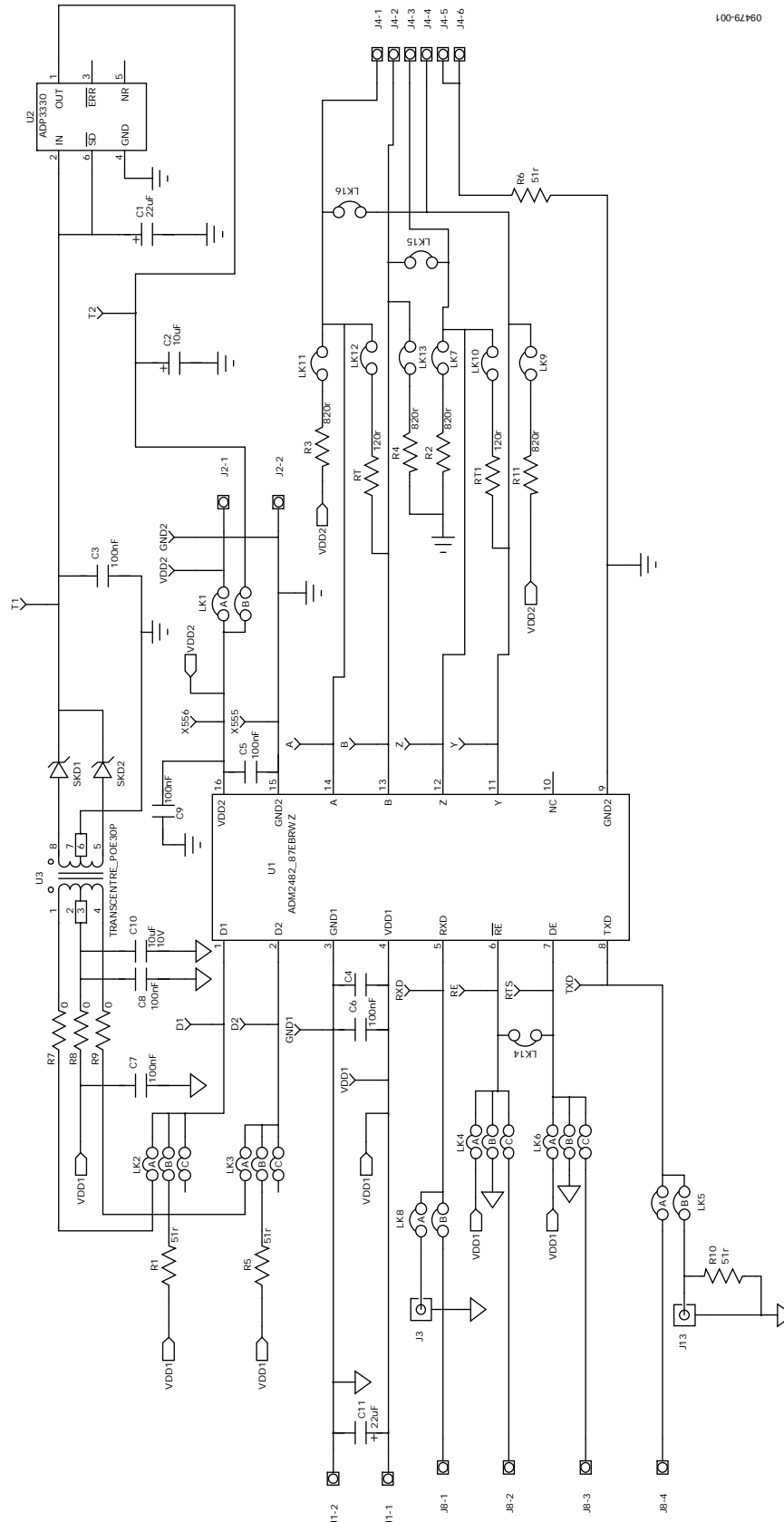

Figure 2. ADM2482E/ADM2487E Evaluation Board Circuit Diagram

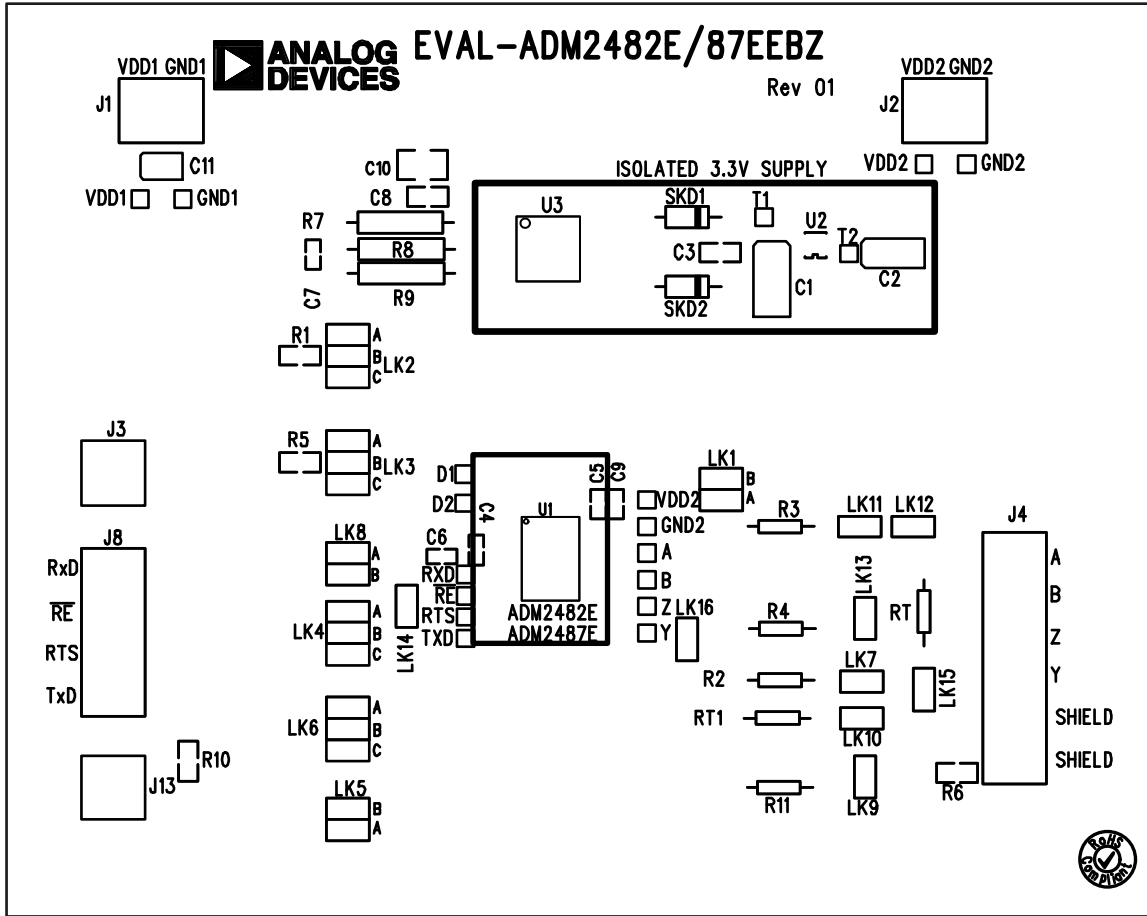
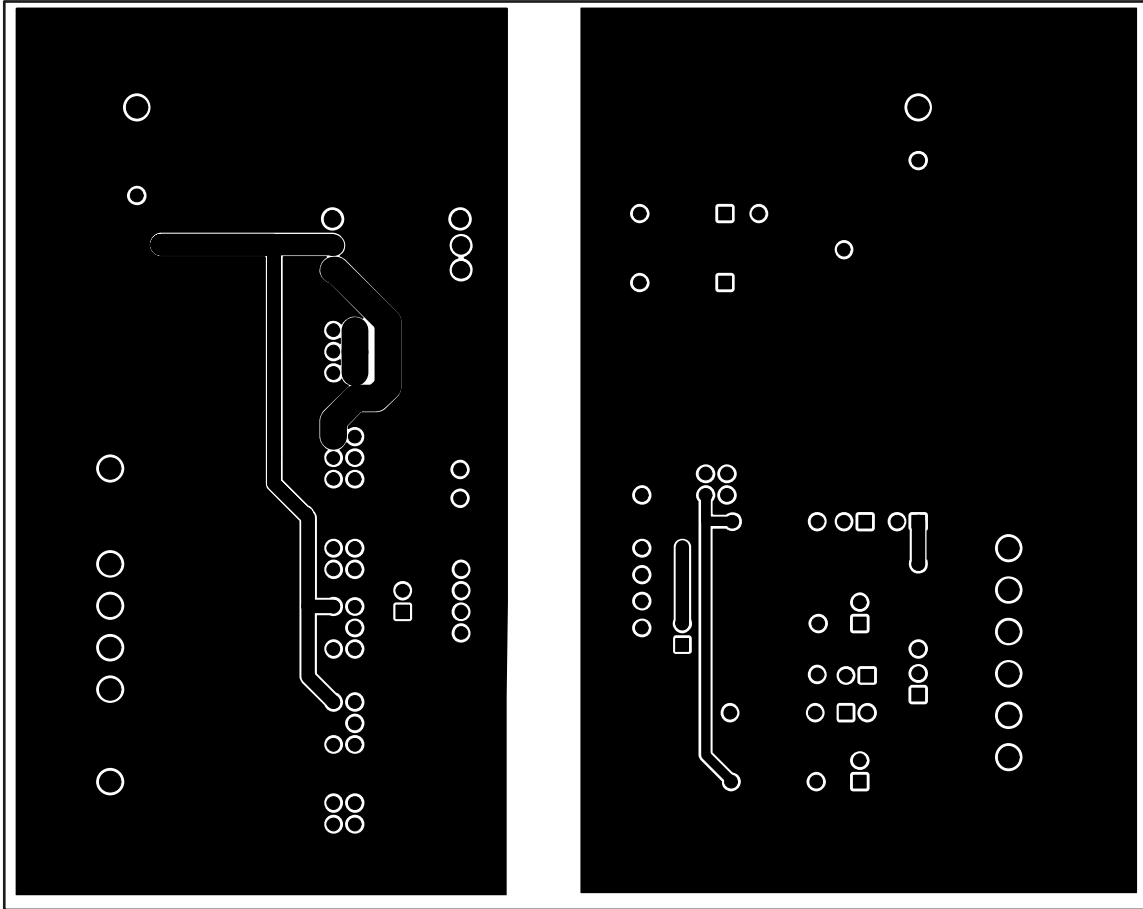
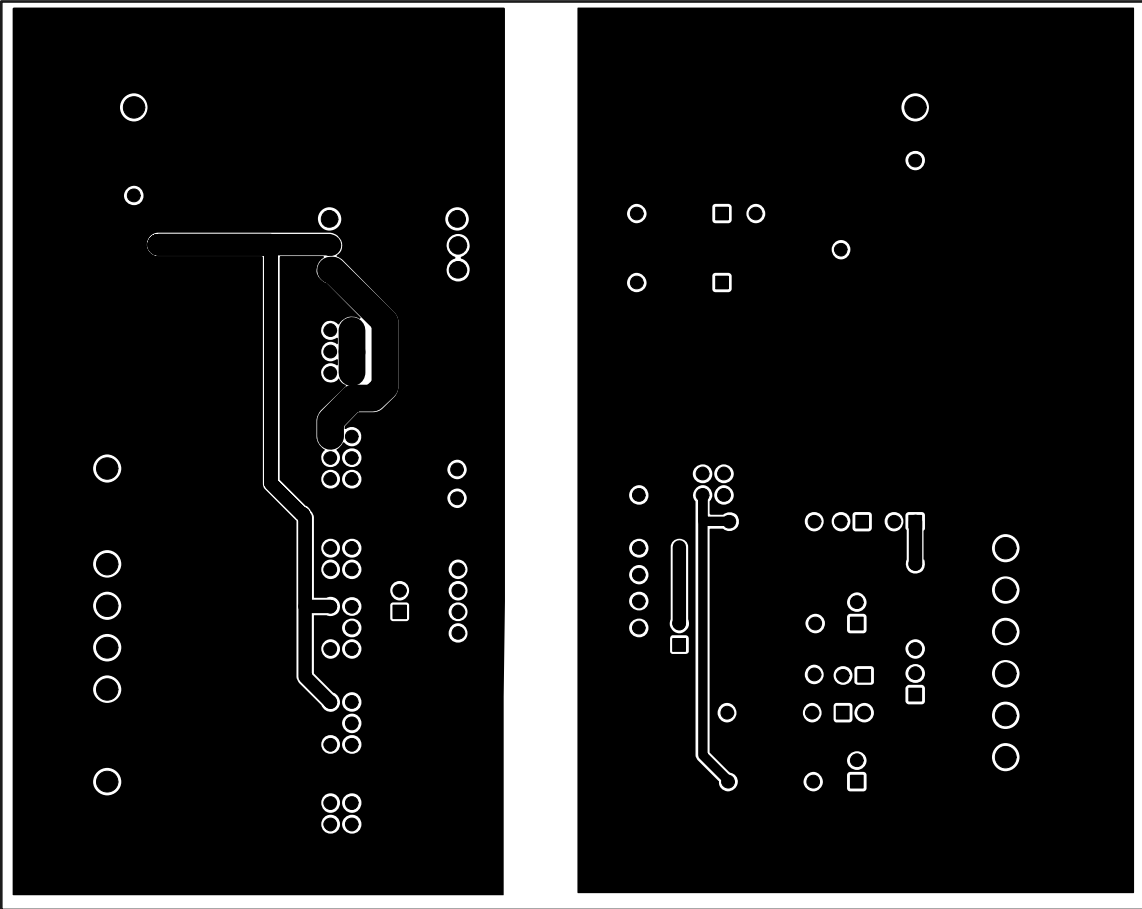

Figure 3. ADM2482E/ADM2487E Evaluation Board Silkscreen



09479-004

Figure 4. ADM2482E/ADM2487E Evaluation Board Component Side



09479-005

Figure 5. ADM2482E/ADM2487E Evaluation Board Solder Side

## ORDERING INFORMATION

### BILL OF MATERIALS

Table 2.

Qty	Reference Designator	Description	Supplier/Part Number
1	C1	Capacitor, Size 1210, 22 $\mu$ F	AVX 1210ZD226KAT2A
2	C2, C10	Capacitor, Size 1210, 10 $\mu$ F	AVX 1210ZC106KAT2A
2	C3, C8	Capacitor, Size 0805, 100 nF	AVX 08055C104KAT2A
1	C4	Capacitor, Size 0603, 100 nF	Do not insert
3	C5, C6, C7	Capacitor, Size 0603, 100 nF	AVX CM105X7R104K16AT
1	C9	Capacitor, Size 0603, 100 nF	Do not insert
1	C11	Capacitor, CAP\TAJ_B, 22 $\mu$ F	AVX TAJB226K016R
2	J1, J2	CON\POWER	Camden CTB5000/2
2	J3, J13	SMB	Radiall R114426000
1	J4	CON\POWER6	Wieland Electric 25.161.0653.0
1	J8	CON\POWER4	Camden CTB5000/4
1 <sup>1</sup>	LK1 to LK16	Header, 2 row, 36 + 36 way	Harwin M20-9983646
2	LK1, LK5	JUMPER_2, JUMPER_2_SWAP_AB	Harwin M7566-05
4	LK2 to LK4, LK6	JUMPER_3	Harwin M7566-05
9	LK7, LK9 to LK16	Jumper, SIP-2P	Harwin M7566-05
1	LK8	JUMPER_2	Harwin M7566-05
4	R1, R5, R6, R10	Resistor, 805, 51 $\Omega$	Multicomp MC 0.1W 0805 5% 51R
4	R2 to R4, R11	Resistor, R1/8W, 820 $\Omega$	Multicomp MCCFR0W8J0821A20
3	R7, R8, R9	Resistor, R1/2W_NARROW, 0 $\Omega$	Wire Link
2	RT, RT1	Resistor, R1/8W, 120 $\Omega$	Multicomp MCCFR0W8J0121A20
6	RE, RTS, RXD, TXD, D1, D2	Test point	Vero 20-313140
6	T1, T2, A, B, Y, Z	Test point	Vero 20-313138
3	VDD1, VDD2, X556	Test point	Vero 20-313137
3	X555, GND1, GND2	Test point	Vero 20-2137
2	SKD1, SKD2	ZPD10, DO35_P, Schottky diode	Fairchild Semiconductor 1N5817
1	U1	RS-485 transceiver, 16-lead SOIC_W	Analog Devices <a href="#">ADM2482EBRWZ/ADM2487EBRWZ</a>
1	U2	LDO, 6-lead SOT-23	Analog Devices <a href="#">ADP3330</a>
1	U3	SMT power transformer	Coilcraft GA3157-AL/Coilcraft DA2303-AL

<sup>1</sup> Only one header is required per board.

### RELATED LINKS

Resource	Description
<a href="#">ADM2482E</a>	Product Page, 2.5 kV Signal Isolated, ESD Protected, Full/Half Duplex RS-485 Transceiver w/ Transformer Driver (16 Mbps)
<a href="#">ADM2487E</a>	Product Page, 2.5 kV Signal Isolated, ESD Protected, Full/Half Duplex RS-485 Transceiver w/ Transformer Driver (500 kbps)
<a href="#">ADP3330</a>	Product Page, High Accuracy Ultralow I(Q), 200 mA, SOT-23, anyCAP® Low Dropout Regulator

**NOTES**

**NOTES**

## NOTES

**ESD Caution**

**ESD (electrostatic discharge) sensitive device.** Charged devices and circuit boards can discharge without detection. Although this product features patented or proprietary protection circuitry, damage may occur on devices subjected to high energy ESD. Therefore, proper ESD precautions should be taken to avoid performance degradation or loss of functionality.

**Legal Terms and Conditions**

By using the evaluation board discussed herein (together with any tools, components documentation or support materials, the "Evaluation Board"), you are agreeing to be bound by the terms and conditions set forth below ("Agreement") unless you have purchased the Evaluation Board, in which case the Analog Devices Standard Terms and Conditions of Sale shall govern. Do not use the Evaluation Board until you have read and agreed to the Agreement. Your use of the Evaluation Board shall signify your acceptance of the Agreement. This Agreement is made by and between you ("Customer") and Analog Devices, Inc. ("ADI"), with its principal place of business at One Technology Way, Norwood, MA 02062, USA. Subject to the terms and conditions of the Agreement, ADI hereby grants to Customer a free, limited, personal, temporary, non-exclusive, non-sublicensable, non-transferable license to use the Evaluation Board FOR EVALUATION PURPOSES ONLY. Customer understands and agrees that the Evaluation Board is provided for the sole and exclusive purpose referenced above, and agrees not to use the Evaluation Board for any other purpose. Furthermore, the license granted is expressly made subject to the following additional limitations: Customer shall not (i) rent, lease, display, sell, transfer, assign, sublicense, or distribute the Evaluation Board; and (ii) permit any Third Party to access the Evaluation Board. As used herein, the term "Third Party" includes any entity other than ADI, Customer, their employees, affiliates and in-house consultants. The Evaluation Board is NOT sold to Customer; all rights not expressly granted herein, including ownership of the Evaluation Board, are reserved by ADI. CONFIDENTIALITY. This Agreement and the Evaluation Board shall all be considered the confidential and proprietary information of ADI. Customer may not disclose or transfer any portion of the Evaluation Board to any other party for any reason. Upon discontinuation of use of the Evaluation Board or termination of this Agreement, Customer agrees to promptly return the Evaluation Board to ADI. ADDITIONAL RESTRICTIONS. Customer may not disassemble, decompile or reverse engineer chips on the Evaluation Board. Customer shall inform ADI of any occurred damages or any modifications or alterations it makes to the Evaluation Board, including but not limited to soldering or any other activity that affects the material content of the Evaluation Board. Modifications to the Evaluation Board must comply with applicable law, including but not limited to the RoHS Directive. TERMINATION. ADI may terminate this Agreement at any time upon giving written notice to Customer. Customer agrees to return to ADI the Evaluation Board at that time. LIMITATION OF LIABILITY. THE EVALUATION BOARD PROVIDED HEREUNDER IS PROVIDED "AS IS" AND ADI MAKES NO WARRANTIES OR REPRESENTATIONS OF ANY KIND WITH RESPECT TO IT. ADI SPECIFICALLY DISCLAIMS ANY REPRESENTATIONS, ENDORSEMENTS, GUARANTEES, OR WARRANTIES, EXPRESS OR IMPLIED, RELATED TO THE EVALUATION BOARD INCLUDING, BUT NOT LIMITED TO, THE IMPLIED WARRANTY OF MERCHANTABILITY, TITLE, FITNESS FOR A PARTICULAR PURPOSE OR NON-INFRINGEMENT OF INTELLECTUAL PROPERTY RIGHTS. IN NO EVENT WILL ADI AND ITS LICENSORS BE LIABLE FOR ANY INCIDENTAL, SPECIAL, INDIRECT, OR CONSEQUENTIAL DAMAGES RESULTING FROM CUSTOMER'S POSSESSION OR USE OF THE EVALUATION BOARD, INCLUDING BUT NOT LIMITED TO LOST PROFITS, DELAY COSTS, LABOR COSTS OR LOSS OF GOODWILL. ADI'S TOTAL LIABILITY FROM ANY AND ALL CAUSES SHALL BE LIMITED TO THE AMOUNT OF ONE HUNDRED US DOLLARS (\$100,000). EXPORT. Customer agrees that it will not directly or indirectly export the Evaluation Board to another country, and that it will comply with all applicable United States federal laws and regulations relating to exports. GOVERNING LAW. This Agreement shall be governed by and construed in accordance with the substantive laws of the Commonwealth of Massachusetts (excluding conflict of law rules). Any legal action regarding this Agreement will be heard in the state or federal courts having jurisdiction in Suffolk County, Massachusetts, and Customer hereby submits to the personal jurisdiction and venue of such courts. The United Nations Convention on Contracts for the International Sale of Goods shall not apply to this Agreement and is expressly disclaimed.

## Looking for pricing, stock, or lifecycle information?

Click below to explore more details on WIN SOURCE:

 [View EVAL-ADM2487EEB5Z on WIN SOURCE](#)

 [Analog Devices Inc. Information](#)

## Optimize Your Supply Chain with WIN SOURCE Solutions

-  Global Sourcing Solution
-  Obsolete Management
-  Cost Control Management
-  Shortage Management
-  Alternative Solution
-  Excess Inventory Management