



**THE DATASHEET OF
TLV4062QDBVRQ1**



TLV4062-Q1, TLV4082-Q1 Dual, Low-Power Comparator with Integrated Reference

1 Features

- Qualified for automotive applications
- AEC-Q100 qualified with the following results:
 - Device temperature grade 1: -40°C to 125°C ambient operating temperature range
 - Device HBM ESD classification level H1C
 - Device CDM ESD classification level C4B
- Wide supply voltage range: 1.5 V to 5.5 V
- Two-channel detectors in small packages
- High threshold accuracy: 1% over temperature
- Precision hysteresis: 60 mV
- Low quiescent current: 2 μA (typ)
- Temperature range: -40°C to $+125^{\circ}\text{C}$
- Push-pull (TLV4062-Q1) and open-drain (TLV4082-Q1) output options
- Available in an SOT-23 package

2 Applications

- [Emergency call \(eCall\)](#)
- [Automotive head unit](#)
- [Instrument cluster](#)
- [On-board \(OBC\) & wireless charger](#)

3 Description

The TLV4062-Q1 and TLV4082-Q1 are a family of high-accuracy, dual-channel comparators featuring low power and small solution size. The IN1 and IN2 inputs include hysteresis to reject brief glitches, thus ensuring stable output operation without false triggering.

The TLV4062-Q1 and TLV4082-Q1 have adjustable INx inputs that can be configured by an external resistor divider pair. When the voltage at the IN1 or IN2 input goes below the falling threshold, OUT1 or OUT2 is driven low, respectively. When IN1 or IN2 rises above the rising threshold, OUT1 or OUT2 goes high, respectively.

The comparators have a very low quiescent current of 2 μA (typical) and provide a precise, space-conscious solution for low-power, voltage monitoring. The TLV4062-Q1 and TLV4082-Q1 operate from 1.5 V to 5.5 V, over the -40°C to $+125^{\circ}\text{C}$ temperature range.

Device Information (1)

PART NUMBER	PACKAGE	BODY SIZE (NOM)
TLV4062-Q1, TLV4082-Q1	SOT-23 (6)	2.90 mm × 1.60 mm

- (1) For all available packages, see the orderable addendum at the end of the datasheet.

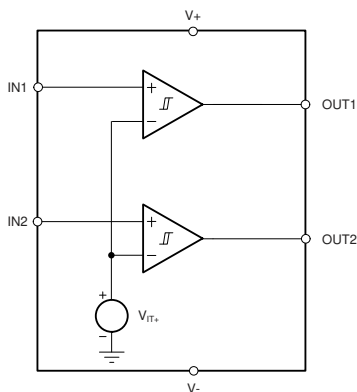

Block Diagram for TLV4062-Q1

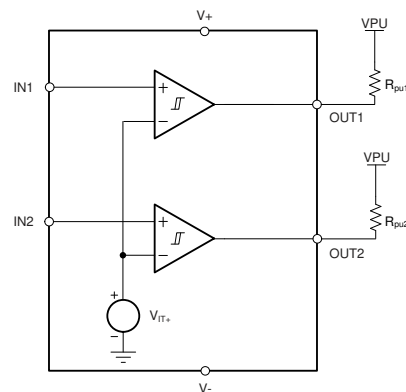

Block Diagram for TLV4082-Q1



Table of Contents

1 Features	1	7.3 Feature Description.....	11
2 Applications	1	7.4 Device Functional Modes.....	11
3 Description	1	8 Application and Implementation	13
4 Revision History	2	8.1 Application Information.....	13
5 Pin Configuration and Functions	3	8.2 Typical Applications.....	13
6 Specifications	4	9 Power Supply Recommendations	19
6.1 Absolute Maximum Ratings.....	4	10 Layout	20
6.2 ESD Ratings.....	4	10.1 Layout Guidelines.....	20
6.3 Recommended Operating Conditions.....	4	10.2 Layout Example.....	20
6.4 Thermal Information.....	5	11 Device and Documentation Support	21
6.5 Electrical Characteristics.....	5	11.1 Documentation Support.....	21
6.6 Timing Requirements.....	6	11.2 Receiving Notification of Documentation Updates..	21
6.7 Timing Diagrams	6	11.3 Support Resources.....	21
6.8 Typical Characteristics.....	7	11.4 Trademarks.....	21
7 Detailed Description	10	11.5 Electrostatic Discharge Caution.....	21
7.1 Overview.....	10	11.6 Glossary.....	21
7.2 Functional Block Diagrams.....	10		

4 Revision History

DATE	REVISION	NOTES
October 2020	*	Initial release.

5 Pin Configuration and Functions

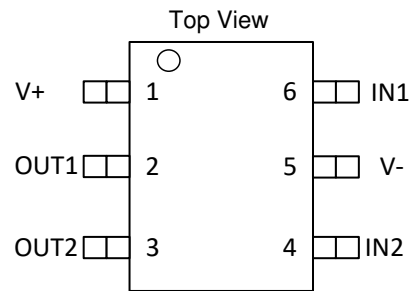

Figure 5-1. DBV Package, 6-Pin SOT-23

Table 5-1. Pin Functions

NAME	NO.	I/O	DESCRIPTION
	DBV		
GND	5	—	Ground
OUT1	2	O	OUT1 is the output for IN1. OUT1 is asserted (driven low) when the voltage at IN1 falls below V_{IT-} . OUT1 is deasserted (goes high) after IN1 rises higher than V_{IT+} . OUT1 is a push-pull output for the TLV4062 and an open-drain output for the TLV4082. The open-drain device (TLV4082) can be pulled up to 5.5 V independent of $V+$; a pullup resistor is required for this device.
OUT2	3	O	OUT2 is the output for IN2. OUT2 is asserted (driven low) when the voltage at IN2 falls below V_{IT-} . OUT2 is deasserted (goes high) after IN2 rises higher than V_{IT+} . OUT2 is a push-pull output for the TLV4062 and an open-drain output for the TLV4082. The open-drain device (TLV4082) can be pulled up to 5.5 V independent of $V+$; a pullup resistor is required for this device.
IN1	6	I	This pin is connected to the voltage to be monitored with the use of an external resistor divider. When the voltage at this pin drops below the threshold voltage (V_{IT-}), OUT1 is asserted.
IN2	4	I	This pin is connected to the voltage to be monitored with the use of an external resistor divider. When the voltage at this pin drops below the threshold voltage (V_{IT-}), OUT2 is asserted.
$V+$	1	I	Supply voltage input. Connect a 1.5-V to 5.5-V supply to $V+$ in order to power the device. Good analog design practice is to place a 0.1- μ F ceramic capacitor close to this pin (required for $V+ < 1.5$ V).

6 Specifications

6.1 Absolute Maximum Ratings

over operating junction temperature range (unless otherwise noted)⁽¹⁾

		MIN	MAX	UNIT
Voltage	VDD	-0.3	7	V
	OUT1, OUT2 (push-pull only)	-0.3	VDD + 0.3	
	OUT1, OUT2 (open-drain only)	-0.3	7	
	IN1, IN2	-0.3	7	
Current	IN1, IN2 ⁽²⁾		10	mA
	OUT1, OUT2		±20	
Temperature	Operating junction, T _J ⁽³⁾	-40	125	°C
	Storage, T _{stg}	-65	150	

- (1) Stresses beyond those listed under *Absolute Maximum Ratings* may cause permanent damage to the device. These are stress ratings only, which do not imply functional operation of the device at these or any other conditions beyond those indicated under *Recommended Operating Conditions*. Exposure to absolute-maximum-rated conditions for extended periods may affect device reliability.
- (2) Input terminals are diode-clamped to GND. Input signals that can swing 0.3V below GND must be current-limited to 10mA or less.
- (3) For low-power devices, the junction temperature rise above the ambient temperature is negligible; therefore, the junction temperature is considered equal to the ambient temperature (T_J = T_A).

6.2 ESD Ratings

		VALUE	UNIT
V _(ESD)	Electrostatic discharge	Human-body model (HBM), per AEC Q100-002 ⁽¹⁾	±2000
		Charged-device model (CDM), per AEC Q100-011	±500

- (1) AEC Q100-002 indicates that HBM stressing shall be in accordance with the ANSI/ESDA/JEDEC JS-001 specification.

6.3 Recommended Operating Conditions

over operating junction temperature range (unless otherwise noted)

		MIN	NOM	MAX	UNIT
	Power-supply voltage	1.5		5.5	V
	Input voltage	0	IN1, IN2	5.5	V
	Output voltage (push-pull only)	0	OUT1, OUT2	VDD + 0.3	V
	Output voltage (open-drain only)	0	OUT1, OUT2	5.5	V
R _{PU}	Pullup resistor (open-drain only)	1.5		10,000	kΩ
	Current	-5	OUT1, OUT2	5	mA
C _{IN}	Input capacitor		0.1		μF
T _J	Junction temperature	-40	25	125	°C

6.4 Thermal Information

THERMAL METRIC ⁽¹⁾		TLV4062, TLV4082		UNIT
		DBV (SOT-23)	DRY (μSON)	
		6 PINS	6 PINS	
R _{θJA}	Junction-to-ambient thermal resistance	193.9	306.7	°C/W
R _{θJC(top)}	Junction-to-case (top) thermal resistance	134.5	174.1	°C/W
R _{θJB}	Junction-to-board thermal resistance	39.0	173.4	°C/W
ψ _{JT}	Junction-to-top characterization parameter	30.4	30.9	°C/W
ψ _{JB}	Junction-to-board characterization parameter	38.5	171.6	°C/W
R _{θJC(bot)}	Junction-to-case (bottom) thermal resistance	N/A	65.2	°C/W

(1) For more information about traditional and new thermal metrics, see the [Semiconductor and IC Package Thermal Metrics](#) application report.

6.5 Electrical Characteristics

all specifications are over the operating temperature range of $-40^{\circ}\text{C} < T_J < +125^{\circ}\text{C}$ and $1.5\text{ V} \leq \text{VDD} \leq 5.5\text{ V}$ (unless otherwise noted); typical values are at $T_J = 25^{\circ}\text{C}$ and $\text{VDD} = 3.3\text{ V}$

PARAMETER	TEST CONDITIONS	MIN	TYP	MAX	UNIT	
VDD	Input supply range	1.5		5.5	V	
V _(POR)	Power-on-reset voltage ⁽¹⁾			0.8	V	
I _{DD}	Supply current (into VDD pin)	VDD = 3.3 V, no load		2.09	μA	
		VDD = 5.5 V, no load		2.29		
V _{IT+}	Positive-going (rising) input threshold voltage	V _(INx) rising		1.194	V	
		-1%	1%			
V _{IT-}	Negative-going (falling) input threshold voltage	V _(INx) falling		1.134	V	
		-1%	1%			
V _{HYS}	In-built Hysteresis		60		mV	
I _(INx)	Input current	V _(INx) = 0 V or VDD		-15	nA	
V _{OL}	Low-level output voltage	VDD ≥ 1.5 V, I _{SINK} = 0.4 mA		0.25	V	
		VDD ≥ 2.7 V, I _{SINK} = 2 mA		0.25		
		VDD ≥ 4.5 V, I _{SINK} = 3.2 mA		0.30		
V _{OH}	High-level output voltage (push-pull only)	VDD ≥ 1.5 V, I _{SOURCE} = 0.4 mA		0.8 VDD	V	
		VDD ≥ 2.7 V, I _{SOURCE} = 1 mA		0.8 VDD		
		VDD ≥ 4.5 V, I _{SOURCE} = 2.5 mA		0.8 VDD		
I _{lkg(OD)}	Open-drain output leakage current (open-drain only)	High impedance, V _(INx) = V _(OUTx) = 5.5 V		-250	250	nA

(1) Outputs are undetermined below V_(POR).

6.6 Timing Requirements

typical values are at $T_J = 25^\circ\text{C}$ and $V_{DD} = 3.3\text{ V}$; INx transitions between 0 V and 1.3 V

		MIN	NOM	MAX	UNIT
$t_{PD(r)}$	INx (rising) to OUTx propagation delay		5.5		μs
$t_{PD(f)}$	INx (falling) to OUTx propagation delay		10		μs
t_{SD}	Startup delay ⁽¹⁾		570		μs

- (1) During power-on or when a VDD transient is below $V_{DD}(\text{min})$, the outputs reflect the input conditions 570 μs after VDD transitions through $V_{DD}(\text{min})$.

6.7 Timing Diagrams

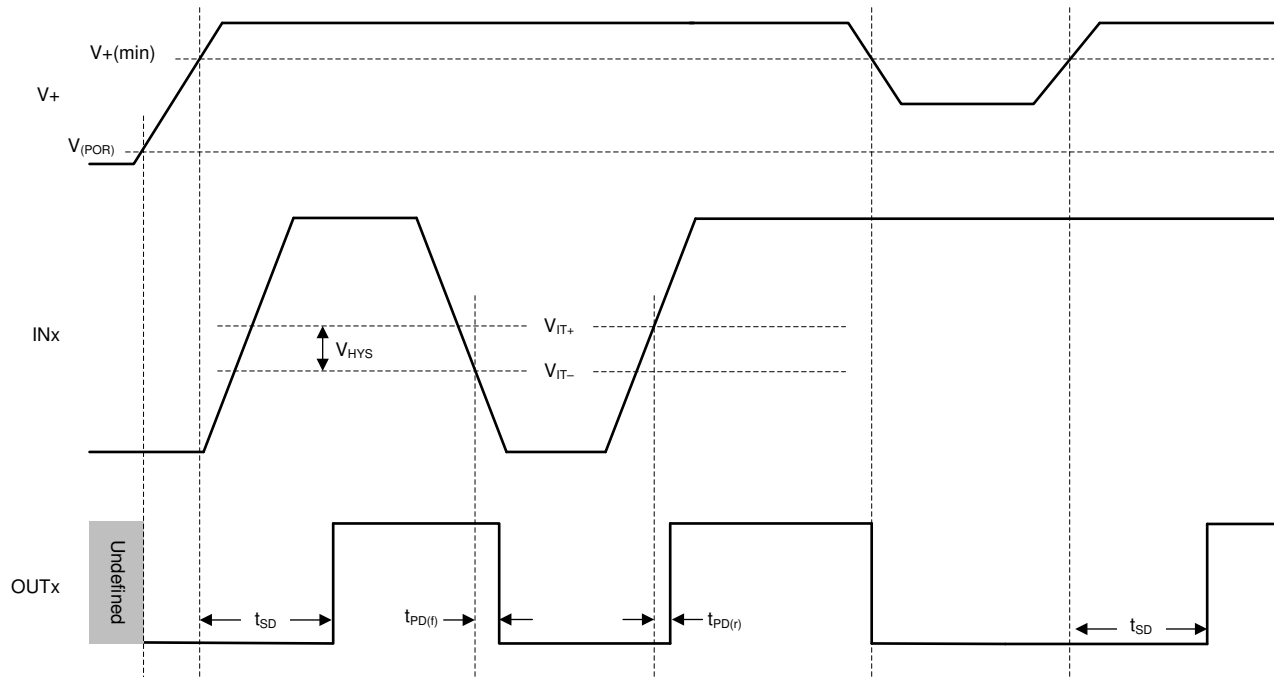

Figure 6-1.

6.8 Typical Characteristics

at $T_J = 25^\circ\text{C}$ with a 0.1- μF capacitor close to V_+ (unless otherwise noted)

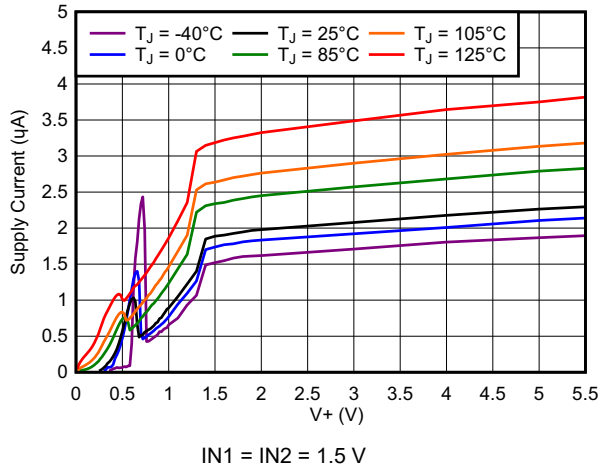

Figure 6-2. Supply Current vs Supply Voltage

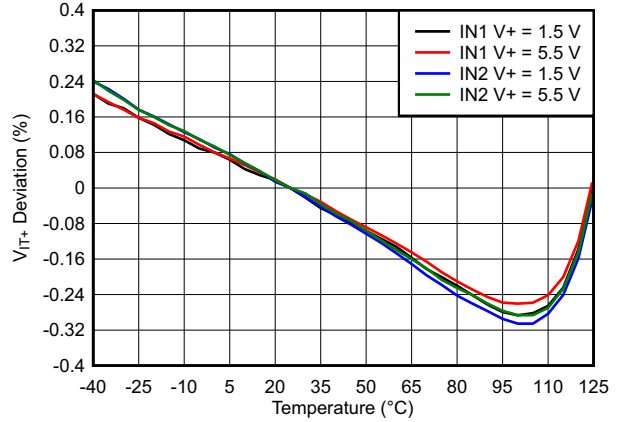

Figure 6-3. INx Threshold (V_{IT+}) Deviation vs Temperature

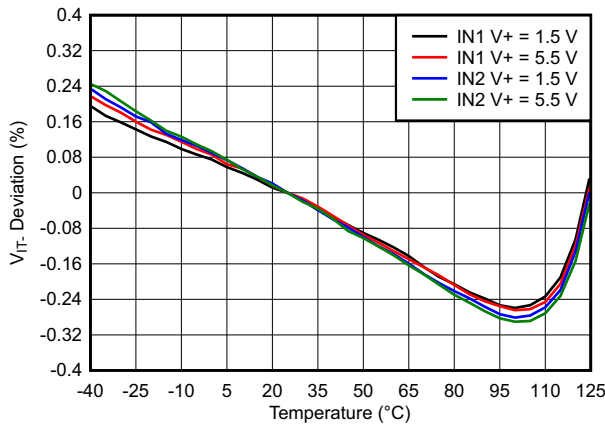

Figure 6-4. INx Threshold (V_{IT-}) Deviation vs Temperature

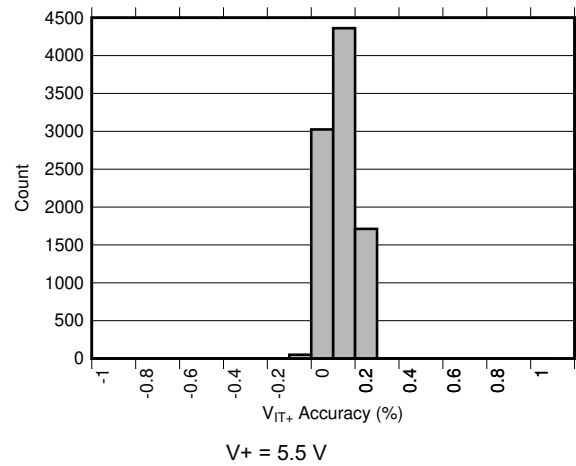

Figure 6-5. INx Threshold (V_{IT+})

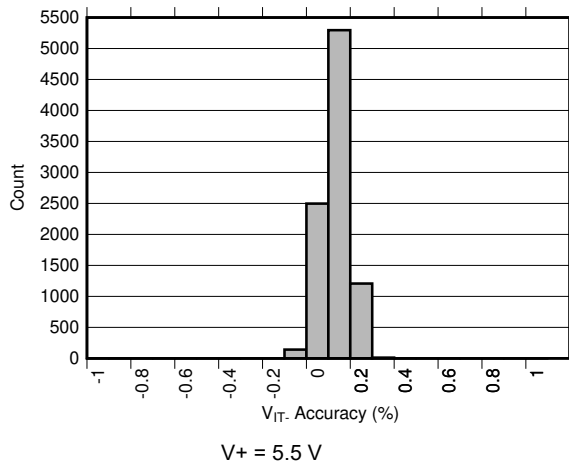

Figure 6-6. INx Threshold (V_{IT-})

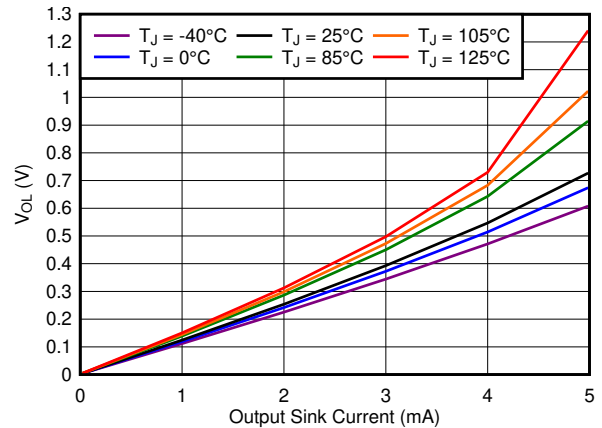

Figure 6-7. Output Voltage Low vs Output Current ($V_+ = 1.5\text{ V}$)

6.8 Typical Characteristics (continued)

at $T_J = 25^\circ\text{C}$ with a 0.1- μF capacitor close to $V+$ (unless otherwise noted)

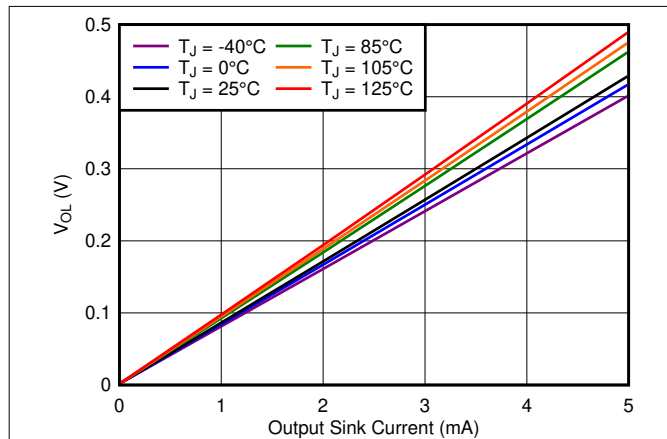

Figure 6-8. Output Voltage Low vs Output Current ($V+ = 3.3\text{ V}$)

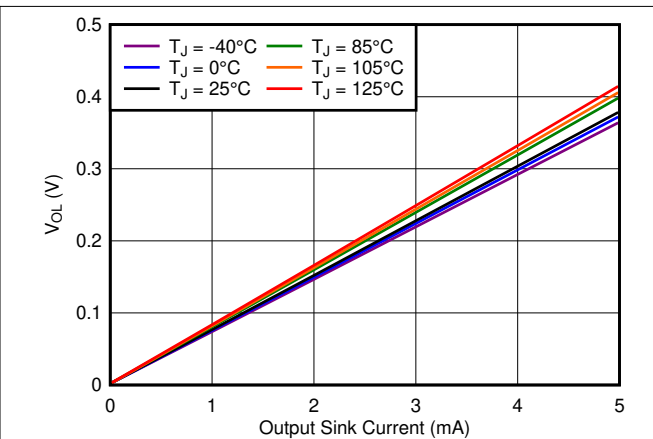

Figure 6-9. Output Voltage Low vs Output Current ($V+ = 5.5\text{ V}$)

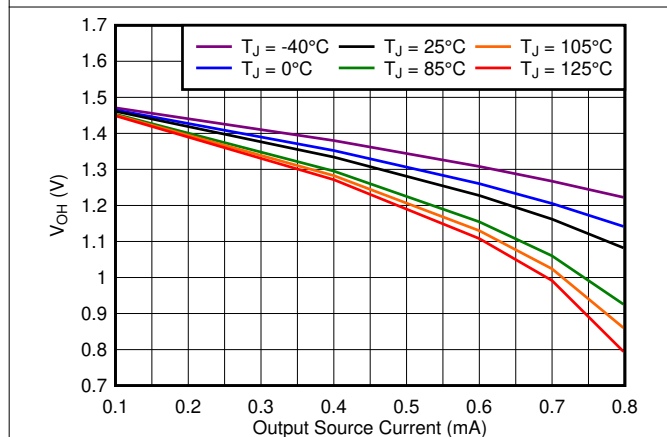

Figure 6-10. Output Voltage High vs Output Current ($V+ = 1.5\text{ V}$)

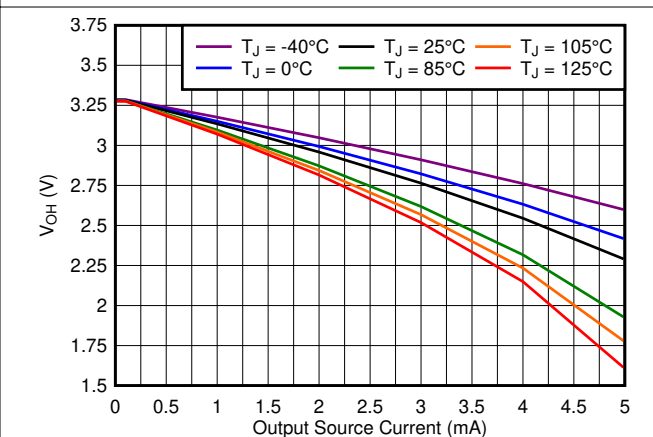

Figure 6-11. Output Voltage High vs Output Current ($V+ = 3.3\text{ V}$)

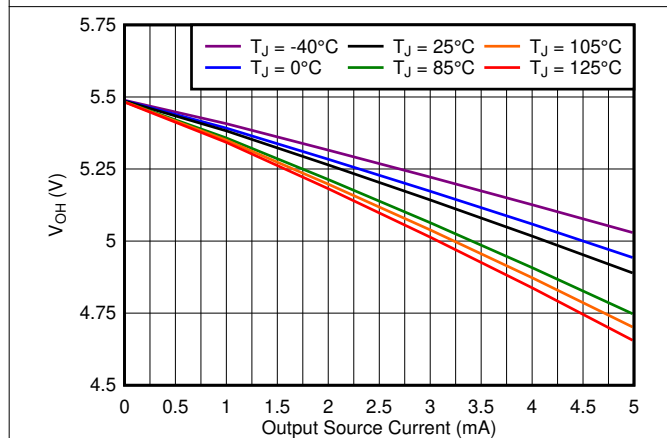

Figure 6-12. Output Voltage High vs Output Current ($V+ = 5.5\text{ V}$)

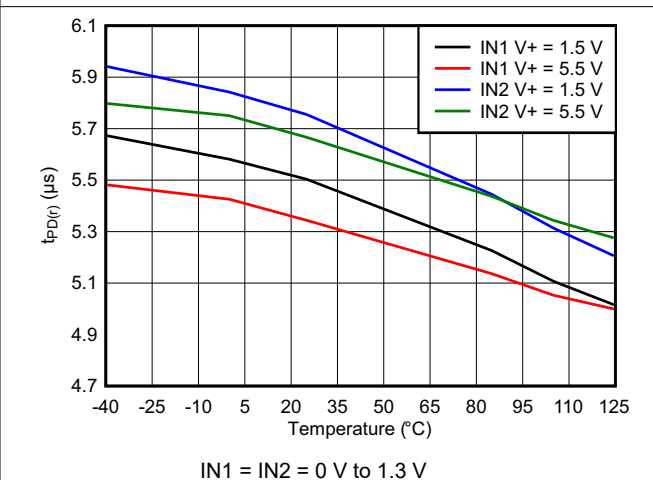
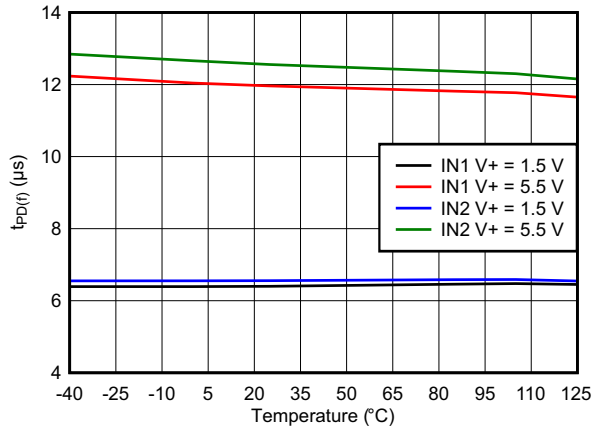

Figure 6-13. Propagation Delay from INx High to Output High

6.8 Typical Characteristics (continued)

at $T_J = 25^\circ\text{C}$ with a 0.1- μF capacitor close to $V+$ (unless otherwise noted)



IN1 = IN2 = 1.3 V to 0 V

Figure 6-14. Propagation Delay from INx Low to Output Low

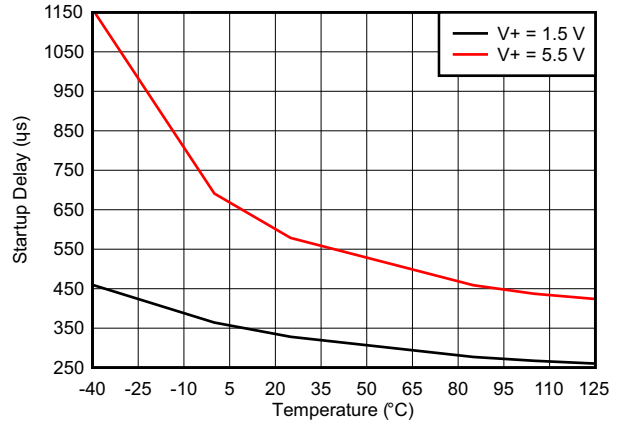
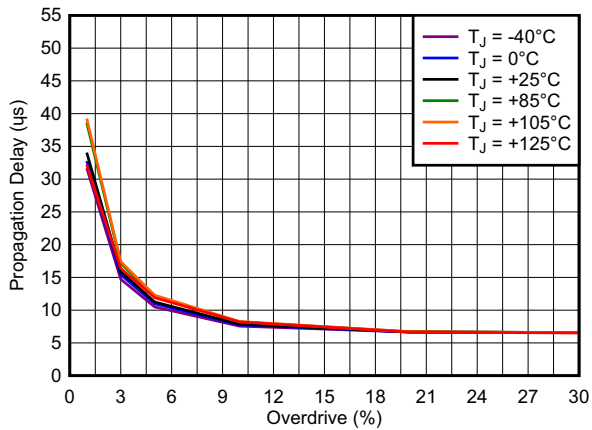
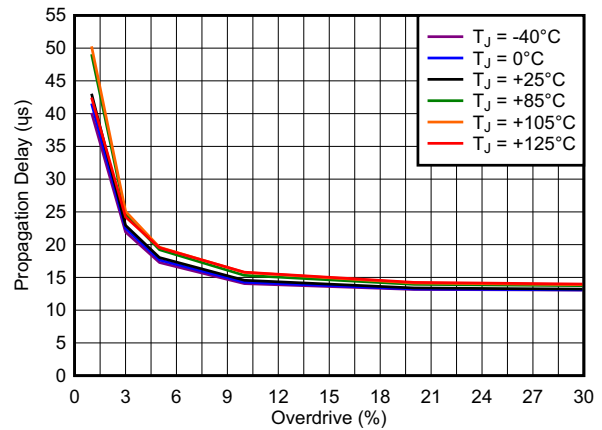

Figure 6-15. Startup Delay



High-to-low transition occurs above the curve

Figure 6-16. Propagation Delay vs Overdrive ($V+ = 1.5\text{ V}$)



High-to-low transition occurs above the curve

Figure 6-17. Propagation Delay vs Overdrive ($V+ = 5.5\text{ V}$)

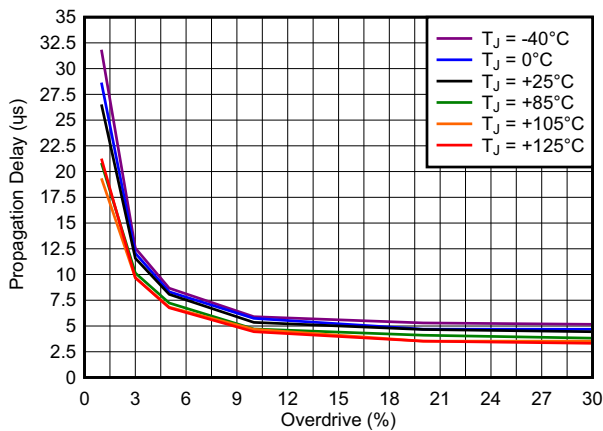

Low-to-high transition occurs above the curve

Figure 6-18. Propagation Delay vs Overdrive ($V+ = 1.5\text{ V}$)

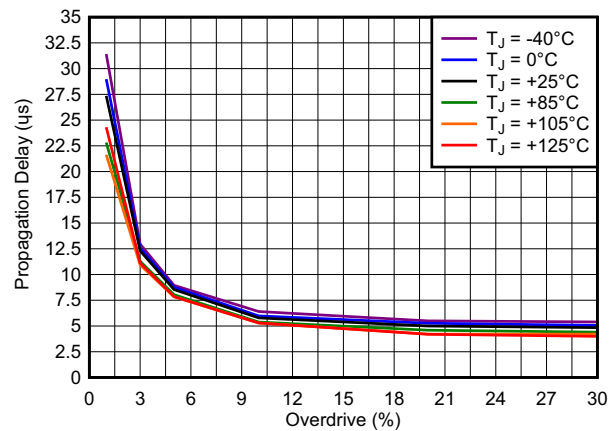

Low-to-high transition occurs above the curve

Figure 6-19. Propagation Delay vs Overdrive ($V+ = 5.5\text{ V}$)

7 Detailed Description

7.1 Overview

The TLV4062-Q1 and TLV4082-Q1 are small, low quiescent current (I_{DD}), dual-channel comparators. These devices have high-accuracy, rising and falling input thresholds, and assert the output as shown in [Table 7-1](#). The output (OUTx) transitions high when the input (INx) is rising and greater than V_{IT+} ; the output (OUTx) will remain high until the input is falling and drops below V_{IT-} . The TLV4062-Q1 and TLV4082-Q1 can be used in systems where multiple voltage rails are required to be monitored, or where one channel can be used as an early warning signal and the other channel can be used as the system reset signal.

Table 7-1. TLV4062-Q1 and TLV4082-Q1 Truth Table

DEVICE	(V_{IT+} , V_{IT-})	OUTPUT TOPOLOGY	INPUT VOLTAGE		OUTPUT LOGIC LEVEL
TLV4062-Q1	1.194V, 1.134V	Push-Pull	$IN1 < V_{IT-}$	IN1 falling	OUT1 = low
			$IN2 < V_{IT-}$	IN2 falling	OUT2 = low
			$IN1 > V_{IT+}$	IN1 rising	OUT1 = high
			$IN2 > V_{IT+}$	IN2 rising	OUT2 = high
TLV4082-Q1		Open-Drain	$IN1 < V_{IT-}$	IN1 falling	OUT1 = low
			$IN2 < V_{IT-}$	IN2 falling	OUT2 = low
			$IN1 > V_{IT+}$	IN1 rising	OUT1 = high
			$IN2 > V_{IT+}$	IN2 rising	OUT2 = high

7.2 Functional Block Diagrams

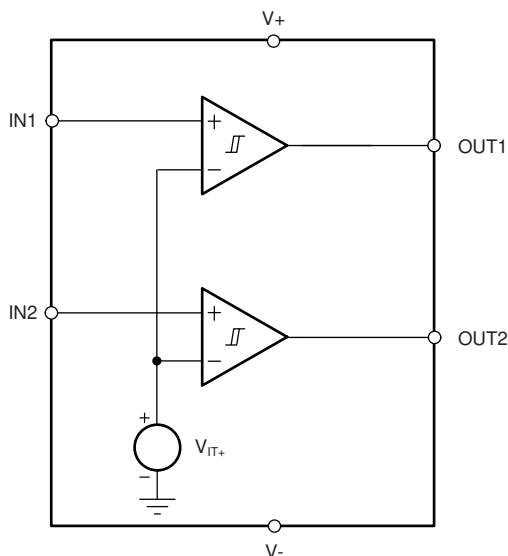

Figure 7-1. TLV4062-Q1 (Push-Pull Output) Block Diagram

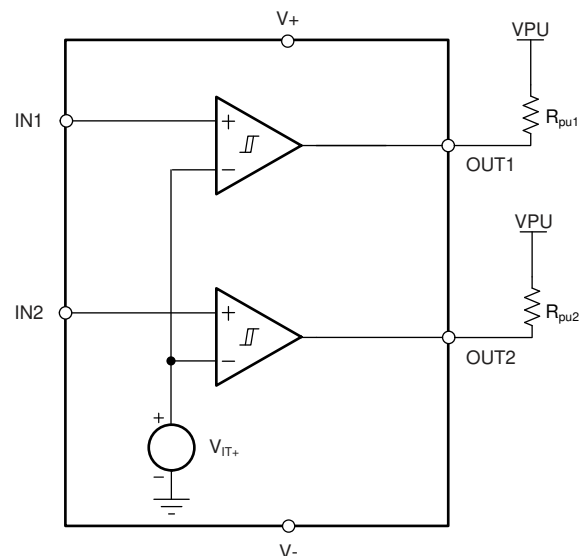

Figure 7-2. TLV4082-Q1 (Open-Drain Output) Block Diagram

7.3 Feature Description

The TLV4062-Q1 (push-pull) and TLV4082-Q1 (open-drain) devices are micro-power, dual-channel comparators that are capable of operating at low voltages. The TLV4062-Q1 and TLV4082-Q1 features high-accuracy integrated reference thresholds with internal hysteresis of 60mV. If the voltage at the inputs, INx, rises above the threshold, the outputs, OUTx, are driven high; if the voltage at the inputs, INx, falls below the threshold, the outputs, OUTx, are driven low.

7.4 Device Functional Modes

When the voltage on V+ is lower than $V_{(POR)}$, both outputs are undefined and are not to be relied upon for proper system function.

7.4.1 Inputs (IN1, IN2)

The TLV4062-Q1 and TLV4082-Q1 each have two comparators for voltage detection. Each comparator has one external input; the other input is connected to the internal reference. The comparator rising threshold is designed and trimmed to be equal to V_{IT+} , and the falling threshold is trimmed to be equal to V_{IT-} . The difference between V_{IT+} and V_{IT-} is referred to as the comparator hysteresis and is 60 mV. The integrated hysteresis makes the TLV40x2 less sensitive to supply-rail noise and provides stable operation in noisy environments without having to add external positive feedback to create hysteresis.

The comparator inputs can swing from ground to 5.5 V, regardless of the device supply voltage used. This includes the instance when no supply voltage is applied to the comparator ($V+ = 0$ V). As a result, the TLV40x2 is referred to as fault tolerant, meaning it maintains the same high input impedance when V+ is unpowered or ramping up. Although not required in most cases, for extremely noisy applications, good analog design practice is to place a 1-nF to 10-nF bypass capacitor at the comparator input in order to reduce sensitivity to transients and layout parasitic.

For each INx input, the corresponding output (OUTx) is driven to logic low when the input voltage drops below V_{IT-} . When the voltage exceeds V_{IT+} , the output (OUTx) is driven high; see [Figure 6-1](#).

7.4.2 Outputs (OUT1, OUT2)

The TLV4062-Q1 features push-pull output stages which eliminates the need for an external pull-up resistor, thus saving board space, while providing a low impedance output driver. The logic high level of the outputs is determined by the V+ pin voltage.

The TLV4082-Q1 features open-drain output stages which enables the output logic levels to be pulled-up to an external source as high as 5.5 V independent of the supply voltage. Pull-up resistors must be used to hold these lines high when the output goes to a high-impedance condition (not asserted). By connecting pull-up resistors to the proper voltage rails, the outputs can be connected to other devices at correct interface voltage levels. To ensure proper voltage levels, make sure to choose the correct pull-up resistor values. The pull-up resistor value is determined by V_{OL} , the sink current capability, and the output leakage current ($I_{IKg(OD)}$). These values are specified in the [Section 6.5](#) table. By using wired-OR logic, OUT1 and OUT2 can be combined into one logic signal. The [Section 7.4.1](#) section describes how the outputs are asserted or de-asserted. See [Figure 6-1](#) for a description of the relationship between threshold voltages and the respective output.

7.4.3 Switching Threshold and Hysteresis

The TLV40x2-Q1 transfer curve is show in [Figure 7-3](#).

- V_{IT+} represents the rising input threshold that causes the comparator output to change from a logic low state to a logic high state.
- V_{IT-} represents the falling input threshold that causes the comparator output to change from logic high state to a logic low state.
- V_{HYS} represents the difference between V_{IT+} and V_{IT-} and is 60 mV for TLV40x2-Q1.

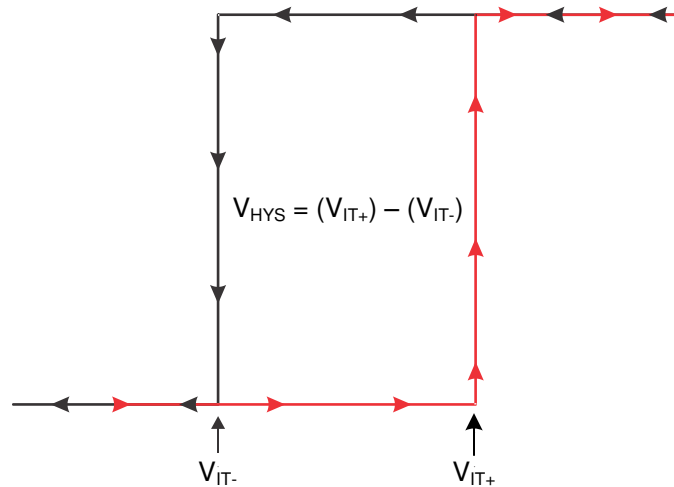

Figure 7-3. TLV40x2 Transfer Curve

8 Application and Implementation

Note

Information in the following applications sections is not part of the TI component specification, and TI does not warrant its accuracy or completeness. TI's customers are responsible for determining suitability of components for their purposes. Customers should validate and test their design implementation to confirm system functionality.

8.1 Application Information

The TLV4062-Q1 and TLV4082-Q1 are used as precision, dual-voltage monitors. The monitored voltage, V+ voltage, and output pullup voltage (TLV4082-Q1 only) can be independent voltages or connected in any configuration.

In a typical device application, the outputs are connected to a reset or enable input of another device, such as a digital signal processor (DSP), central processing unit (CPU), field-programmable gate array (FPGA), or application-specific integrated circuit (ASIC); or the outputs are connected to the enable input of a voltage regulator, such as a dc-dc or low-dropout (LDO) regulator.

8.1.1 Threshold Overdrive

Threshold overdrive is how much V_{IN1} or V_{IN2} exceeds the specified threshold, and is important to know because a smaller overdrive results in a slower OUTx response. Threshold overdrive is calculated as a percent of the threshold in question, as shown in [Equation 1](#):

$$\text{Overdrive} = | (V_{IN1,2} / V_{IT} - 1) \times 100\% | \quad (1)$$

where

- V_{IT} is either V_{IT-} or V_{IT+} , depending on whether calculating the overdrive for the falling input threshold or the rising input threshold, respectively
- $V_{IN1,2}$ is the voltage at the IN1 or IN2 input

[Figure 6-16](#) and [Figure 6-17](#) illustrates the minimum detectable pulse on the INx inputs versus overdrive, and is used to visualize the relationship that overdrive has on $t_{PD(f)}$ for high to low transitions. [Figure 6-18](#) and [Figure 6-19](#) is used to visual the relationship that overdrive has on $t_{PD(r)}$ for low to high transitions.

8.2 Typical Applications

8.2.1 Monitoring Two Separate Rails

The TLV40x2-Q1 series can be used to monitor two separate rails for over voltage detection. Over-voltage monitoring is frequently used for system protection to alert the system to shutdown to prevent from damage. The TLV4062-Q1 and TLV4082-Q1 also have adjustable INx inputs that can be configured to monitor voltages using external resistor divider, as shown in [Figure 8-1](#).

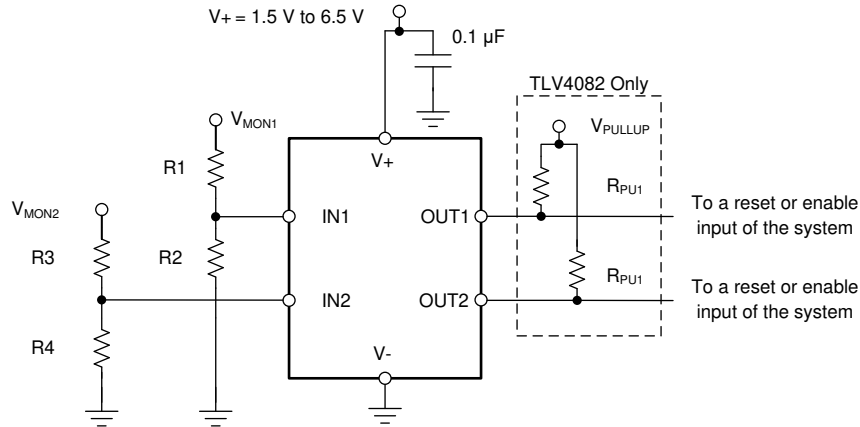

Figure 8-1. Monitoring Two Separate Rails Schematic

8.2.1.1 Design Requirements

For this design, follow these requirements:

- $V_{MON1} = 5\text{ V}$ and $V_{MON2} = 3.3\text{ V}$
- Set V_{MON1} over-voltage condition at 6.5 V
- Set V_{MON2} over-voltage condition at 4 V

8.2.1.2 Detailed Design Procedure

Configure the circuit as shown in Figure 8-1. Connect $V+$ to a power supply that is compatible with the input logic level of the device connected to the output, and connect $V-$ to ground. Resistors R_1 and R_2 create the over-voltage alert level at 6.5 V and resistors R_3 and R_4 create the over-voltage alert level at 4 V . When the V_{MON} rises, the resistor divider voltage crosses V_{IT+} . This causes the comparator output to transition from a logic low level (normal operation), to a logic high level. When V_{MON} falls back down and the resistor divider voltage crosses V_{IT-} and signal that the system is approaching normal operating voltage levels once again. Make sure to set V_{MON} at a value below the absolute maximum voltage of the system in question.

$$V_{IT+} = \frac{R_2}{R_2 + R_1} \times V_{MON} \quad (2)$$

where

- R_1/R_3 and R_2/R_4 are the resistor values for the resistor divider connected to INx
- V_{MON} is the voltage source that is being monitored for an over-voltage condition
- V_{IT+} is the rising edge threshold where the comparator output changes state from low to high

Rearranging Equation 2 and solving for R_1 yields Equation 3. Set R_2/R_4 to a fixed value.

$$R_1 = \frac{V_{MON} - V_{IT+}}{V_{IT+}} \times R_2 \quad (3)$$

Using the nearest 1% resistors and the equation above, $R_1 = 300\text{ k}\Omega$, $R_2 = 1.33\text{ M}\Omega$, $R_3 = 953\text{ k}\Omega$, and $R_4 = 407\text{ k}\Omega$. To get the trip point as close as possible to rising threshold, V_{IT+} , V_{MON} are adjusted so that $V_{MON1} = 6.49\text{ V}$ and $V_{MON2} = 3.99\text{ V}$. Using equation Equation 4 will determine when the output will fall low (crossing V_{IT-}). The over-voltage signal will go low when $V_{MON1} = 6.16\text{ V}$ and $V_{MON2} = 3.79\text{ V}$.

$$V_{MON} = \frac{R_2 + R_1}{R_2} \times V_{IT-} \quad (4)$$

where

- V_{MON} is the voltage at which the resistor divider crosses the falling threshold, V_{IT} .

Choose R_{TOTAL} (equal to $R1 + R2 + R3 + R4$) so that the current through the divider is approximately 100 times higher than the input current at the INx pins. The resistors can have high values to minimize current consumption as a result of low input bias current without adding significant error to the resistive divider. For details on sizing input resistors, see the [Optimizing Resistor Dividers at a Comparator Input](#) application report (SLVA450), available for download from www.ti.com.

8.2.1.3 Application Curve

Figure 8-2 shows the simulated results of monitoring two independent voltage rails for an over-voltage event.

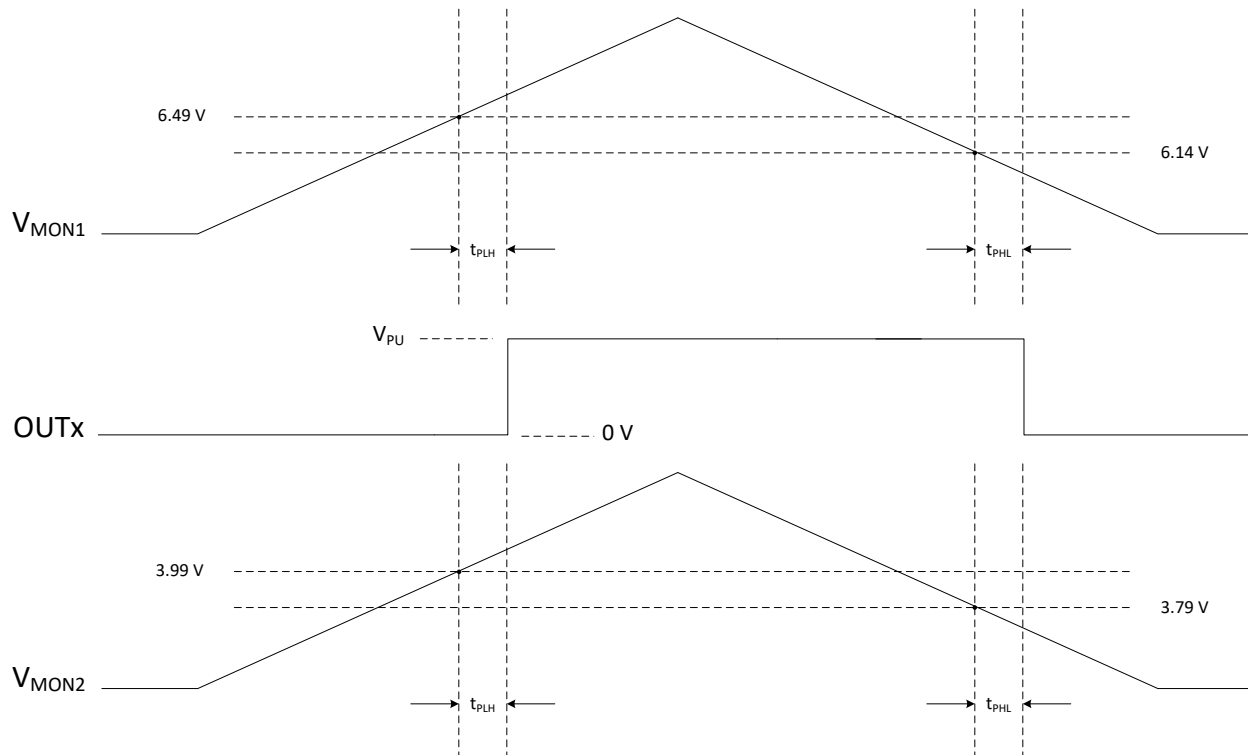

Figure 8-2. Overvoltage Detection

8.2.2 Early Warning Detection

The TLV40x2-Q1 series can be used to monitor for early warning detection where OUT1 sends an early warning alert signal and OUT2 sends an alert signal. This type of topology can be used for sensitive systems so a warning alert can trigger before system shutdown occurs. The TLV4062-Q1 and TLV4082-Q1 also have adjustable INx inputs that can be configured to monitor voltages using external resistor divider, as shown in Figure 8-3.

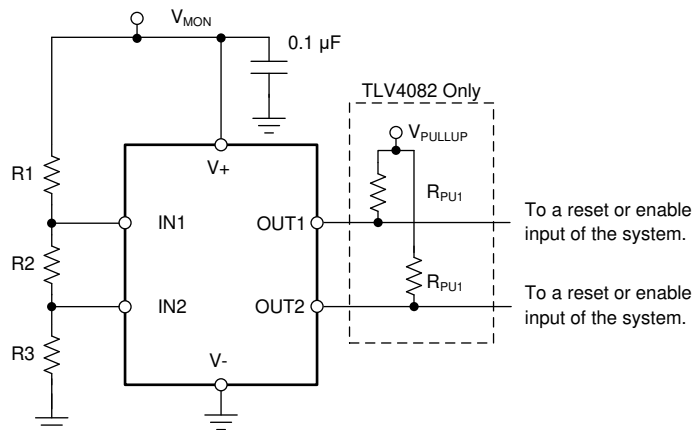

Figure 8-3. Early Warning Detection Schematic

8.2.2.1 Design Requirements

For this design, follow these requirements:

- $V_{MON} = 3.3V$
- Set the transition points $V_{MON1} = 3.5 V$ and $V_{MON2} = 3.9 V$

8.2.2.2 Detailed Design Procedure

Configure the circuit as shown in [Figure 8-3](#). Connect V+ to a 3.3 V power rail and connect V- to ground. The resistor network is used to create an early warning detection signal at OUT2, which will give a warning alert as V_{MON} approaches the max limit, changing state from a logic low to a logic high. OUT2 will stay high for a longer period until V_{MON} is no longer in the warning zone. OUT1 will be used when V_{MON} reaches the max limit and transition from a logic low to a logic high. This type of topology can be used for sensitive systems where advanced notice of the power supply over-voltage detection is needed.

Use V_{MON2} , the threshold for a low to high transition at OUT2, I_{IN_RES} , the current flow through the resistor network, to determine the minimum total resistance necessary to achieve the current consumption specification.

$$R_{total} = \frac{V_{MON2}}{I_{IN_RES}} \quad (5)$$

where

- V_{MON2} is the target voltage at which OUT2 goes high when V_{MON} rises
- I_{IN_RES} is the current flowing through the resistor network

After R_{TOTAL} is determined, R3 can be calculated using [Equation 6](#). Select the nearest 1% resistor value for R3. In this case, 845 kΩ is the closest value.

$$R_3 = \frac{V_{IT+}}{I_{IN_RES}} \quad (6)$$

Use the voltage divider equation [Equation 7](#) The voltage divider equation controls the V_{MON1} voltage at which OUT1 will transition from a logic high to a logic low.

$$V_{IT+} = \frac{R_2 + R_3}{R_{TOTAL}} \times V_{MON1} \quad (7)$$

where

- V_{MON1} is the target voltage at which OUT1 goes low when V_{MON} falls

Rearranging [Equation 7](#) to solve for R2 yields [Equation 8](#) Select the nearest 1% resistor value for R2. In this case, 55.6kΩ is the closest value.

$$R_2 = \frac{R_{TOTAL}}{V_{MON1}} \times V_{IT-} - R_3 \quad (8)$$

Use [Equation 9](#) to calculate R1. Select the nearest 1% resistor value for R1. In this case, 1.87 MΩ is a 1% resistor.

$$R_1 = R_{TOTAL} - R_2 - R_3 \quad (9)$$

8.2.2.3 Application Curve

Figure 8-4 shows the simulated results of the early warning detection circuit. OUT2 provides the early warning alert whereas OUT1 provides the warning alert.

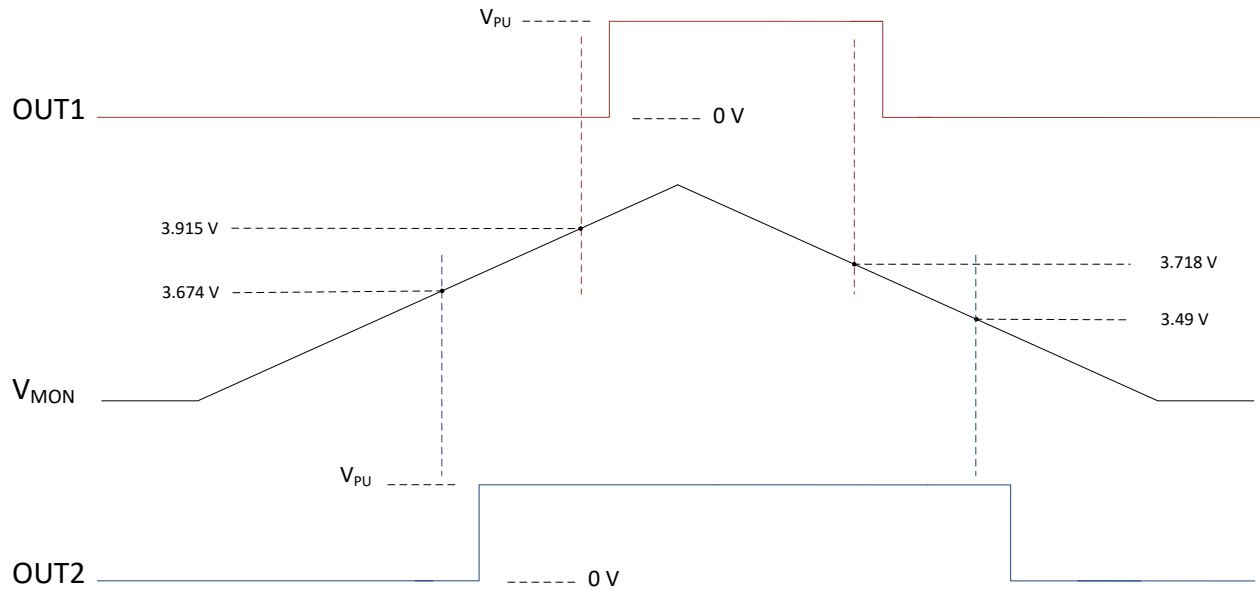

Figure 8-4. Early Warning Detection

8.2.3 Additional Application Information

8.2.3.1 Pull-Up Resistor Selection

For the TLV4082-Q1 (open-drain outputs), care should be taken in selecting the pull-up resistor (R_{PU}) value to ensure proper output voltage levels. First, consider the required output high logic level requirement of the logic device that is being driven by the comparator when calculating the maximum R_{PU} value. When in a logic high output state, the output impedance of the comparator is very high but there is finite amount of leakage current that needs to be accounted for. Use the $|I_{lk(OD)}|$ from the EC table and the $V_{IH(min)}$ of the logic device being driven by the TLV4082 to determine R_{PU} using Equation 10.

$$R_{PU(max)} = \frac{(V_{PU} - V_{IH(min)})}{I_{O-LKG}} \quad (10)$$

Next determine the minimum value for R_{PU} by using the $V_{IL(max)}$ of the logic device being driven by the TLV4082-Q1. In order for the comparator output to be recognized as a logic low, $V_{IL(max)}$ is used to determine the upper boundary of the comparator's V_{OL} . $V_{OL(max)}$ for the comparator is available in the EC table from specific sink current levels and can be found from the V_{OUT} versus I_{SINK} curve in the Typical Applications curve. A good design practice is to choose a value for V_{OL} that is $\frac{1}{2}$ the value of V_{IL} for the input logic device. The corresponding sink current and V_{OL} value will be needed to calculate the minimum R_{PU} . This method will ensure enough noise margin for the logic low level. With i_{SINK} determined and the corresponding R_{PU} obtained, the minimum R_{PU} is calculated with Equation 11.

$$R_{PU(min)} = \frac{(V_{PU} - V_{OL(max)})}{I_{SINK}} \quad (11)$$

Since the range of possible R_{PU} values is large, a value between 5 k Ω and 100k Ω is generally recommended. A smaller R_{PU} value provides faster output transition time and better noise immunity, while a larger R_{PU} value consumes less power when in a logic low output state.

8.2.3.2 INx Capacitor

Although not required in most cases, for extremely noisy applications, place a 1 nF to 100 nF bypass capacitor from the comparator input (INx) to the (V-) for good analog design practice. This capacitor placement reduces device sensitivity to transients.

9 Power Supply Recommendations

The TLV4062-Q1 and TLV4082-Q1 are designed to operate from an input voltage supply range between 1.5 V and 5.5V. An input supply capacitor is not required for this device; however, good analog practice is to place a 0.1- μ F or greater capacitor between the V+ pin and the GND pin. This device has a 7-V absolute maximum rating on the V+ pin. If the voltage supply providing power to V+ is susceptible to any large voltage transient that can exceed 7 V, additional precautions must be taken.

For applications where INx is greater than 0 V before V+, and is subject to a startup slew rate of less than 200 mV per 1 ms, the output can be driven to logic high in error. To correct the output, cycle the INx lines below V_{IT-} or sequence INx after V+.

10 Layout

10.1 Layout Guidelines

Place the V+ decoupling capacitor close to the device.

Avoid using long traces for the V+ supply node. The V+ capacitor, along with parasitic inductance from the supply to the capacitor, can form an LC tank circuit that creates ringing with peak voltages above the maximum V+ voltage.

10.2 Layout Example

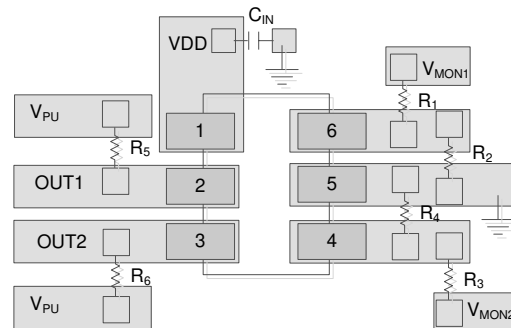

Figure 10-1. Example SOT-23 Layout

11 Device and Documentation Support

11.1 Documentation Support

11.1.1 Related Documentation

11.2 Receiving Notification of Documentation Updates

To receive notification of documentation updates, navigate to the device product folder on ti.com. In the upper right corner, click on *Alert me* to register and receive a weekly digest of any product information that has changed. For change details, review the revision history included in any revised document.

11.3 Support Resources

TI E2E™ [support forums](#) are an engineer's go-to source for fast, verified answers and design help — straight from the experts. Search existing answers or ask your own question to get the quick design help you need.

Linked content is provided "AS IS" by the respective contributors. They do not constitute TI specifications and do not necessarily reflect TI's views; see TI's [Terms of Use](#).

11.4 Trademarks

TI E2E™ is a trademark of Texas Instruments.

All trademarks are the property of their respective owners.

11.5 Electrostatic Discharge Caution



This integrated circuit can be damaged by ESD. Texas Instruments recommends that all integrated circuits be handled with appropriate precautions. Failure to observe proper handling and installation procedures can cause damage.

ESD damage can range from subtle performance degradation to complete device failure. Precision integrated circuits may be more susceptible to damage because very small parametric changes could cause the device not to meet its published specifications.

11.6 Glossary

[TI Glossary](#) This glossary lists and explains terms, acronyms, and definitions.

Mechanical, Packaging, and Orderable Information

The following pages include mechanical, packaging, and orderable information. This information is the most current data available for the designated devices. This data is subject to change without notice and revision of this document. For browser-based versions of this data sheet, refer to the left-hand navigation.

PACKAGING INFORMATION

Orderable Device	Status (1)	Package Type	Package Drawing	Pins	Package Qty	Eco Plan (2)	Lead finish/ Ball material (6)	MSL Peak Temp (3)	Op Temp (°C)	Device Marking (4/5)	Samples
TLV4062QDBVRQ1	ACTIVE	SOT-23	DBV	6	3000	RoHS & Green	NIPDAU	Level-2-260C-1 YEAR	-40 to 125	2DK5	Samples
TLV4082QDBVRQ1	ACTIVE	SOT-23	DBV	6	3000	RoHS & Green	NIPDAU	Level-2-260C-1 YEAR	-40 to 125	2DJ5	Samples

(1) The marketing status values are defined as follows:

ACTIVE: Product device recommended for new designs.

LIFEBUY: TI has announced that the device will be discontinued, and a lifetime-buy period is in effect.

NRND: Not recommended for new designs. Device is in production to support existing customers, but TI does not recommend using this part in a new design.

PREVIEW: Device has been announced but is not in production. Samples may or may not be available.

OBSOLETE: TI has discontinued the production of the device.

(2) **RoHS:** TI defines "RoHS" to mean semiconductor products that are compliant with the current EU RoHS requirements for all 10 RoHS substances, including the requirement that RoHS substance do not exceed 0.1% by weight in homogeneous materials. Where designed to be soldered at high temperatures, "RoHS" products are suitable for use in specified lead-free processes. TI may reference these types of products as "Pb-Free".

RoHS Exempt: TI defines "RoHS Exempt" to mean products that contain lead but are compliant with EU RoHS pursuant to a specific EU RoHS exemption.

Green: TI defines "Green" to mean the content of Chlorine (Cl) and Bromine (Br) based flame retardants meet JS709B low halogen requirements of <=1000ppm threshold. Antimony trioxide based flame retardants must also meet the <=1000ppm threshold requirement.

(3) MSL, Peak Temp. - The Moisture Sensitivity Level rating according to the JEDEC industry standard classifications, and peak solder temperature.

(4) There may be additional marking, which relates to the logo, the lot trace code information, or the environmental category on the device.

(5) Multiple Device Markings will be inside parentheses. Only one Device Marking contained in parentheses and separated by a "~" will appear on a device. If a line is indented then it is a continuation of the previous line and the two combined represent the entire Device Marking for that device.

(6) Lead finish/Ball material - Orderable Devices may have multiple material finish options. Finish options are separated by a vertical ruled line. Lead finish/Ball material values may wrap to two lines if the finish value exceeds the maximum column width.

Important Information and Disclaimer:The information provided on this page represents TI's knowledge and belief as of the date that it is provided. TI bases its knowledge and belief on information provided by third parties, and makes no representation or warranty as to the accuracy of such information. Efforts are underway to better integrate information from third parties. TI has taken and continues to take reasonable steps to provide representative and accurate information but may not have conducted destructive testing or chemical analysis on incoming materials and chemicals. TI and TI suppliers consider certain information to be proprietary, and thus CAS numbers and other limited information may not be available for release.

In no event shall TI's liability arising out of such information exceed the total purchase price of the TI part(s) at issue in this document sold by TI to Customer on an annual basis.

OTHER QUALIFIED VERSIONS OF TLV4062-Q1, TLV4082-Q1 :

- Catalog: [TLV4062](#), [TLV4082](#)

NOTE: Qualified Version Definitions:

- Catalog - TI's standard catalog product

TAPE AND REEL INFORMATION

QUADRANT ASSIGNMENTS FOR PIN 1 ORIENTATION IN TAPE

*All dimensions are nominal

Device	Package Type	Package Drawing	Pins	SPQ	Reel Diameter (mm)	Reel Width W1 (mm)	A0 (mm)	B0 (mm)	K0 (mm)	P1 (mm)	W (mm)	Pin1 Quadrant
TLV4062QDBVRQ1	SOT-23	DBV	6	3000	178.0	9.0	3.23	3.17	1.37	4.0	8.0	Q3
TLV4082QDBVRQ1	SOT-23	DBV	6	3000	178.0	9.0	3.23	3.17	1.37	4.0	8.0	Q3

TAPE AND REEL BOX DIMENSIONS

*All dimensions are nominal

Device	Package Type	Package Drawing	Pins	SPQ	Length (mm)	Width (mm)	Height (mm)
TLV4062QDBVRQ1	SOT-23	DBV	6	3000	180.0	180.0	18.0
TLV4082QDBVRQ1	SOT-23	DBV	6	3000	180.0	180.0	18.0

EXAMPLE BOARD LAYOUT

DBV0006A

SOT-23 - 1.45 mm max height

SMALL OUTLINE TRANSISTOR

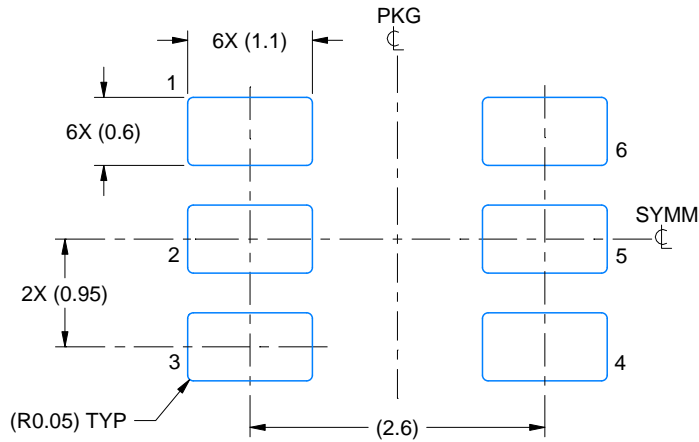

LAND PATTERN EXAMPLE
EXPOSED METAL SHOWN
SCALE:15X

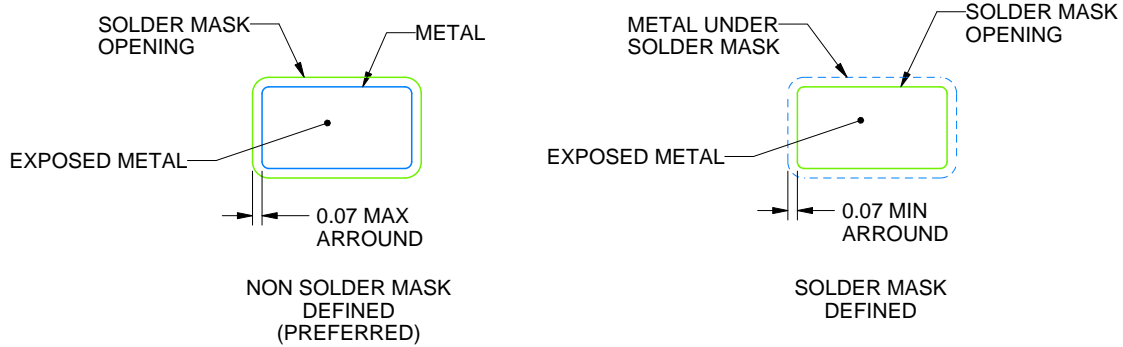

SOLDER MASK DETAILS

4214840/F 05/2024

NOTES: (continued)

6. Publication IPC-7351 may have alternate designs.

7. Solder mask tolerances between and around signal pads can vary based on board fabrication site.

EXAMPLE STENCIL DESIGN

DBV0006A

SOT-23 - 1.45 mm max height

SMALL OUTLINE TRANSISTOR

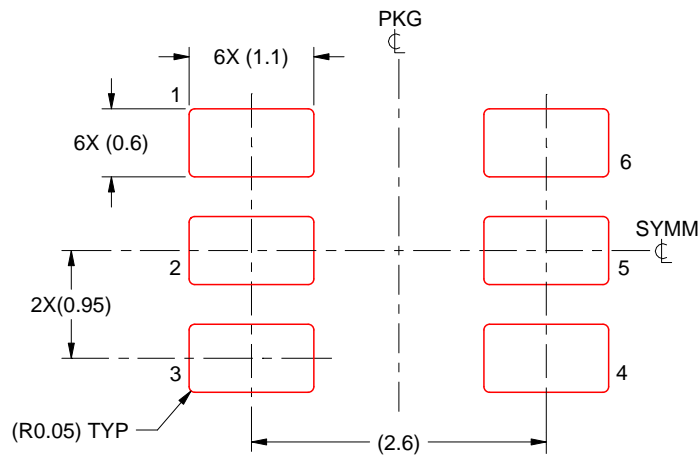

SOLDER PASTE EXAMPLE
BASED ON 0.125 mm THICK STENCIL
SCALE:15X

4214840/F 05/2024

NOTES: (continued)

8. Laser cutting apertures with trapezoidal walls and rounded corners may offer better paste release. IPC-7525 may have alternate design recommendations.
9. Board assembly site may have different recommendations for stencil design.

IMPORTANT NOTICE AND DISCLAIMER

TI PROVIDES TECHNICAL AND RELIABILITY DATA (INCLUDING DATA SHEETS), DESIGN RESOURCES (INCLUDING REFERENCE DESIGNS), APPLICATION OR OTHER DESIGN ADVICE, WEB TOOLS, SAFETY INFORMATION, AND OTHER RESOURCES "AS IS" AND WITH ALL FAULTS, AND DISCLAIMS ALL WARRANTIES, EXPRESS AND IMPLIED, INCLUDING WITHOUT LIMITATION ANY IMPLIED WARRANTIES OF MERCHANTABILITY, FITNESS FOR A PARTICULAR PURPOSE OR NON-INFRINGEMENT OF THIRD PARTY INTELLECTUAL PROPERTY RIGHTS.

These resources are intended for skilled developers designing with TI products. You are solely responsible for (1) selecting the appropriate TI products for your application, (2) designing, validating and testing your application, and (3) ensuring your application meets applicable standards, and any other safety, security, regulatory or other requirements.

These resources are subject to change without notice. TI grants you permission to use these resources only for development of an application that uses the TI products described in the resource. Other reproduction and display of these resources is prohibited. No license is granted to any other TI intellectual property right or to any third party intellectual property right. TI disclaims responsibility for, and you will fully indemnify TI and its representatives against, any claims, damages, costs, losses, and liabilities arising out of your use of these resources.

TI's products are provided subject to [TI's Terms of Sale](#) or other applicable terms available either on [ti.com](https://www.ti.com) or provided in conjunction with such TI products. TI's provision of these resources does not expand or otherwise alter TI's applicable warranties or warranty disclaimers for TI products.

TI objects to and rejects any additional or different terms you may have proposed.

Mailing Address: Texas Instruments, Post Office Box 655303, Dallas, Texas 75265
Copyright © 2024, Texas Instruments Incorporated

Looking for pricing, stock, or lifecycle information?

Click below to explore more details on WIN SOURCE:

 [View TLV4062QDBVRQ1 on WIN SOURCE](#)

 [Texas Instruments](#) Information

Optimize Your Supply Chain with WIN SOURCE Solutions

-  Global Sourcing Solution
-  Obsolete Management
-  Cost Control Management
-  Shortage Management
-  Alternative Solution
-  Excess Inventory Management