

FEATURES

- Operates With 3-V to 5.5-V V_{CC} Supply
- Operates up to 1 Mbit/s
- Low Standby Current . . . 1 μ A Typical
- External Capacitors . . . $4 \times 0.1 \mu$ F
- Accepts 5-V Logic Input With 3.3-V Supply
- Latch-Up Performance Exceeds 100 mA Per JESD 78, Class II
- RS-232 Bus-Pin ESD Protection Exceeds ± 15 kV Using Human-Body Model (HBM)

APPLICATIONS

- Battery-Powered Systems
- PDAs
- Notebooks
- Laptops
- Palmtop PCs
- Hand-Held Equipment

DESCRIPTION/ORDERING INFORMATION

The TRSF3223 consists of two line drivers, two line receivers, and a dual charge-pump circuit with ± 15 -kV ESD protection pin to pin (serial-port connection pins, including GND). The device provides the electrical interface between an asynchronous communication controller and the serial-port connector. The charge pump and four small external capacitors allow operation from a single 3-V to 5.5-V supply. The device operates at data signaling rates up to 1 Mbit/s and a driver output slew rate of 24 V/ μ s to 150 V/ μ s.

Flexible control options for power management are available when the serial port is inactive. The auto-powerdown feature functions when $\overline{\text{FORCEON}}$ is low and $\overline{\text{FORCEOFF}}$ is high. During this mode of operation, if the device does not sense a valid RS-232 signal, the driver outputs are disabled. If $\overline{\text{FORCEOFF}}$ is set low and enable ($\overline{\text{EN}}$) is high, both drivers and receivers are shut off, and the supply current is reduced to 1 μ A. Disconnecting the serial port or turning off the peripheral drivers causes auto-powerdown to occur. Auto-powerdown can be disabled when $\overline{\text{FORCEON}}$ and $\overline{\text{FORCEOFF}}$ are high. With auto-powerdown enabled, the device is activated automatically when a valid signal is applied to any receiver input. The $\overline{\text{INVALID}}$ output is used to notify the user if an RS-232 signal is present at any receiver input. $\overline{\text{INVALID}}$ is high (valid data) if any receiver input voltage is greater than 2.7 V or less than -2.7 V or has been between -0.3 V and 0.3 V for less than 30 μ s. $\overline{\text{INVALID}}$ is low (invalid data) if the receiver input voltage is between -0.3 V and 0.3 V for more than 30 μ s. Refer to [Figure 4](#) for receiver input levels.

DB, DW, OR PW PACKAGE
(TOP VIEW)

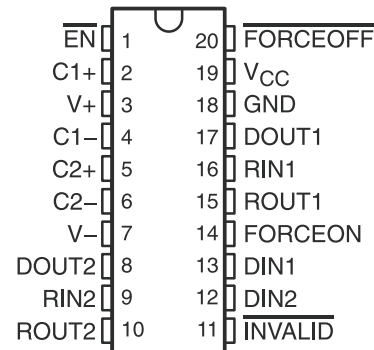

Please be aware that an important notice concerning availability, standard warranty, and use in critical applications of Texas Instruments semiconductor products and disclaimers thereto appears at the end of this data sheet.

TRSF3223
3-V TO 5.5-V MULTICHANNEL RS-232 COMPATIBLE
LINE DRIVER/RECEIVER

SLLS854–AUGUST 2007

ORDERING INFORMATION

T _A	PACKAGE ⁽¹⁾⁽²⁾		ORDERABLE PART NUMBER	TOP-SIDE MARKING
0°C to 70°C	SOIC – DW	Tube of 25	TRSF3223CDW	TRSF3223C
		Reel of 2000	TRSF3223CDWR	
	SSOP – DB	Tube of 70	TRSF3223CDB	RT23C
		Reel of 2000	TRSF3223CDBR	
	TSSOP – PW	Tube of 70	TRSF3223CPW	RT23C
		Reel of 2000	TRSF3223CPWR	
–40°C to 85°C	SOIC – DW	Tube of 25	TRSF3223IDW	TRSF3223I
		Reel of 2000	TRSF3223IDWR	
	SSOP – DB	Tube of 70	TRSF3223IDB	RT23I
		Reel of 2000	TRSF3223IDBR	
	TSSOP – PW	Tube of 70	TRSF3223IPW	RT23I
		Reel of 2000	TRSF3223IPWR	

- (1) Package drawings, thermal data, and symbolization are available at www.ti.com/packaging.
(2) For the most current package and ordering information, see the Package Option Addendum at the end of this document, or see the TI website at www.ti.com.

FUNCTION TABLES

Each Driver⁽¹⁾

INPUTS				OUTPUT DOUT	DRIVER STATUS
DIN	FORCEON	FORCEOFF	VALID RIN RS-232 LEVEL		
X	X	L	X	Z	Powered off
L	H	H	X	H	Normal operation with auto-powerdown disabled
H	H	H	X	L	
L	L	H	Yes	H	Normal operation with auto-powerdown enabled
H	L	H	Yes	L	
L	L	H	No	Z	Powered off by auto-powerdown feature
H	L	H	No	Z	

- (1) H = high level, L = low level, X = irrelevant, Z = high impedance

Each Receiver⁽¹⁾

INPUTS			OUTPUT ROUT
RIN	EN	VALID RIN RS-232 LEVEL	
L	L	X	H
H	L	X	L
X	H	X	Z
Open	L	No	H

- (1) H = high level, L = low level, X = irrelevant,
Z = high impedance (off),
Open = input disconnected or connected driver off

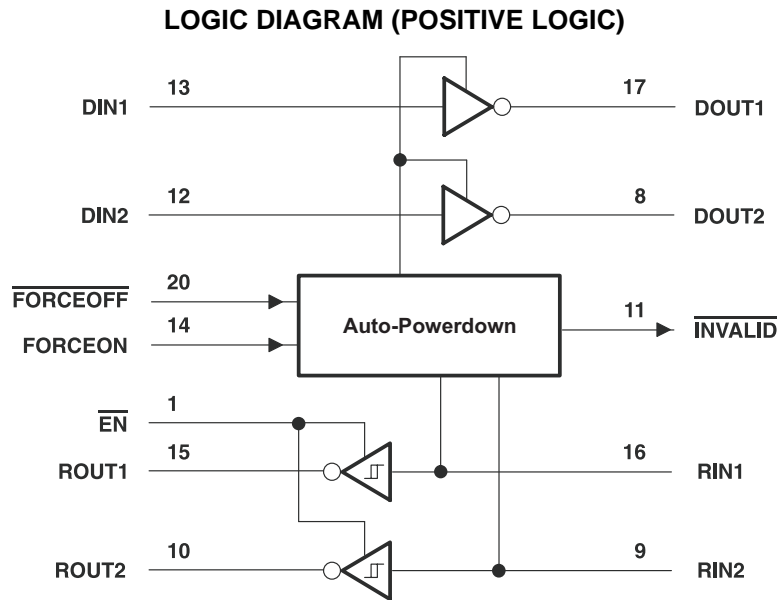

Absolute Maximum Ratings⁽¹⁾

over operating free-air temperature range (unless otherwise noted)

		MIN	MAX	UNIT	
V _{CC}	Supply voltage range ⁽²⁾	-0.3	6	V	
V ₊	Positive-output supply voltage range ⁽²⁾	-0.3	7	V	
V ₋	Negative-output supply voltage range ⁽²⁾	0.3	-7	V	
V ₊ - V ₋	Supply voltage difference ⁽²⁾		13	V	
V _I	Input voltage range	Driver (FORCEOFF, FORCEON, EN)		V	
					-0.3
V _O	Output voltage range	Receiver		V	
					-25
		Driver		V	
					-13.23
		Receiver (INVALID)		V	
					-0.3
θ _{JA}	Package thermal impedance ⁽³⁾⁽⁴⁾	DB package		°C/W	
					70
					58
		PW package		83	
T _J	Operating virtual junction temperature		150	°C	
T _{stg}	Storage temperature range	-65	150	°C	

- (1) Stresses beyond those listed under "absolute maximum ratings" may cause permanent damage to the device. These are stress ratings only, and functional operation of the device at these or any other conditions beyond those indicated under "recommended operating conditions" is not implied. Exposure to absolute-maximum-rated conditions for extended periods may affect device reliability.
- (2) All voltages are with respect to network GND.
- (3) Maximum power dissipation is a function of T_{J(max)}, θ_{JA}, and T_A. The maximum allowable power dissipation at any allowable ambient temperature is P_D = (T_{J(max)} - T_A)/θ_{JA}. Operating at the absolute maximum T_J of 150°C can affect reliability.
- (4) The package thermal impedance is calculated in accordance with JESD 51-7.

TRSF3223
3-V TO 5.5-V MULTICHANNEL RS-232 COMPATIBLE
LINE DRIVER/RECEIVER

SLLS854–AUGUST 2007

Recommended Operating Conditions⁽¹⁾

See [Figure 6](#)

			MIN	NOM	MAX	UNIT
Supply voltage		$V_{CC} = 3.3\text{ V}$	3	3.3	3.6	V
		$V_{CC} = 5\text{ V}$	4.5	5	5.5	
V_{IH}	Driver and control high-level input voltage	DIN, \overline{EN} , FORCEOFF, FORCEON	$V_{CC} = 3.3\text{ V}$	2		V
			$V_{CC} = 5\text{ V}$	2.4		
V_{IL}	Driver and control low-level input voltage	DIN, \overline{EN} , FORCEOFF, FORCEON			0.8	V
V_I	Driver and control input voltage	DIN, \overline{EN} , FORCEOFF, FORCEON	0		5.5	V
	Receiver input voltage		-25		25	
T_A	Operating free-air temperature	TRSF3223C	0		70	°C
		TRSF3223I	-40		85	

(1) Test conditions are C1–C4 = 0.1 μF at $V_{CC} = 3.3\text{ V} \pm 0.3\text{ V}$; C1 = 0.047 μF , C2–C4 = 0.33 μF at $V_{CC} = 5\text{ V} \pm 0.5\text{ V}$.

Electrical Characteristics⁽¹⁾

over recommended ranges of supply voltage and operating free-air temperature (unless otherwise noted) (see [Figure 5](#))

PARAMETER		TEST CONDITIONS	MIN	TYP ⁽²⁾	MAX	UNIT	
I_I	Input leakage current	\overline{EN} , FORCEOFF, FORCEON	± 0.01		± 1	μA	
I_{CC}	Supply current	Auto-powerdown disabled	No load, FORCEOFF, FORCEON at V_{CC}		0.3	1	mA
		Powered off	No load, FORCEOFF at GND		1	10	
		Auto-powerdown enabled	No load, FORCEOFF at V_{CC} , FORCEON at GND, All RIN are open or grounded		1	10	μA

(1) Test conditions are C1–C4 = 0.1 μF at $V_{CC} = 3.3\text{ V} \pm 0.3\text{ V}$; C1 = 0.047 μF , C2–C4 = 0.33 μF at $V_{CC} = 5\text{ V} \pm 0.5\text{ V}$.

(2) All typical values are at $V_{CC} = 3.3\text{ V}$ or $V_{CC} = 5\text{ V}$, and $T_A = 25^\circ\text{C}$.

DRIVER SECTION

Electrical Characteristics⁽¹⁾

over recommended ranges of supply voltage and operating free-air temperature (unless otherwise noted) (see [Figure 6](#))

PARAMETER	TEST CONDITIONS		MIN	TYP ⁽²⁾	MAX	UNIT
V _{OH}	High-level output voltage	DOUT at R _L = 3 kΩ to GND	5	5.4		V
V _{OL}	Low-level output voltage	DOUT at R _L = 3 kΩ to GND	–5	–5.4		V
I _{IH}	High-level input current	V _I = V _{CC}		±0.01	±1	μA
I _{IL}	Low-level input current	V _I at GND		±0.01	±1	μA
I _{OS}	Short-circuit output current ⁽³⁾	V _{CC} = 3.6 V, V _O = 0 V		±35	±60	mA
		V _{CC} = 5.5 V, V _O = 0 V		±35	±90	
r _o	Output resistance	V _{CC} , V+, and V– = 0 V, V _O = ±2 V	300	10M		Ω
I _{off}	Output leakage current	FORCEOFF = GND	V _O = ±12 V, V _{CC} = 3 V to 3.6 V		±25	μA
			V _O = ±10 V, V _{CC} = 4.5 V to 5.5 V		±25	

(1) Test conditions are C1–C4 = 0.1 μF at V_{CC} = 3.3 V ± 0.3 V; C1 = 0.047 μF, C2–C4 = 0.33 μF at V_{CC} = 5 V ± 0.5 V.

(2) All typical values are at V_{CC} = 3.3 V or V_{CC} = 5 V, and T_A = 25°C.

(3) Short-circuit durations should be controlled to prevent exceeding the device absolute power dissipation ratings, and not more than one output should be shorted at a time.

Switching Characteristics⁽¹⁾

over recommended ranges of supply voltage and operating free-air temperature (unless otherwise noted) (see [Figure 6](#))

PARAMETER	TEST CONDITIONS		MIN	TYP ⁽²⁾	MAX	UNIT
Maximum data rate (see Figure 1)	R _L = 3 kΩ, One DOUT switching	C _L = 1000 pF		250		kbit/s
		C _L = 250 pF, V _{CC} = 3 V to 4.5 V		1000		
		C _L = 1000 pF, V _{CC} = 4.5 V to 5.5 V		1000		
t _{sk(p)}	Pulse skew ⁽³⁾	C _L = 150 pF to 2500 pF, R _L = 3 kΩ to 7 kΩ, See Figure 2		300		ns
SR(tr)	Slew rate, transition region (see Figure 1)	V _{CC} = 3.3 V, R _L = 3 kΩ to 7 kΩ, C _L = 150 pF to 1000 pF		18	150	V/μs

(1) Test conditions are C1–C4 = 0.1 μF at V_{CC} = 3.3 V ± 0.3 V; C1 = 0.047 μF, C2–C4 = 0.33 μF at V_{CC} = 5 V ± 0.5 V.

(2) All typical values are at V_{CC} = 3.3 V or V_{CC} = 5 V, and T_A = 25°C.

(3) Pulse skew is defined as |t_{PLH} – t_{PHL}| of each channel of the same device.

RECEIVER SECTION

Electrical Characteristics⁽¹⁾

over recommended ranges of supply voltage and operating free-air temperature (unless otherwise noted) (see [Figure 6](#))

PARAMETER	TEST CONDITIONS	MIN	TYP ⁽²⁾	MAX	UNIT
V _{OH} High-level output voltage	I _{OH} = -1 mA	V _{CC} - 0.6	V _{CC} - 0.1		V
V _{OL} Low-level output voltage	I _{OL} = 1.6 mA			0.4	V
V _{IT+} Positive-going input threshold voltage	V _{CC} = 3.3 V		1.6	2.4	V
	V _{CC} = 5 V		1.9	2.4	
V _{IT-} Negative-going input threshold voltage	V _{CC} = 3.3 V	0.6	1.1		V
	V _{CC} = 5 V	0.8	1.4		
V _{hys} Input hysteresis (V _{IT+} - V _{IT-})			0.5		V
I _{off} Output leakage current	$\overline{EN} = V_{CC}$		±0.05	±10	µA
r _i Input resistance	V _I = ±3 V to ±25 V	3	5	7	kΩ

(1) Test conditions are C1–C4 = 0.1 µF at V_{CC} = 3.3 V ± 0.3 V; C1 = 0.047 µF, C2–C4 = 0.33 µF at V_{CC} = 5 V ± 0.5 V.

(2) All typical values are at V_{CC} = 3.3 V or V_{CC} = 5 V, and T_A = 25°C.

Switching Characteristics⁽¹⁾

over recommended ranges of supply voltage and operating free-air temperature (unless otherwise noted)

PARAMETER	TEST CONDITIONS	TYP ⁽²⁾	UNIT
t _{PLH} Propagation delay time, low- to high-level output	C _L = 150 pF, See Figure 3	150	ns
t _{PHL} Propagation delay time, high- to low-level output	C _L = 150 pF, See Figure 3	150	ns
t _{en} Output enable time	C _L = 150 pF, R _L = 3 kΩ, See Figure 4	200	ns
t _{dis} Output disable time	C _L = 150 pF, R _L = 3 kΩ, See Figure 4	200	ns
t _{sk(p)} Pulse skew ⁽³⁾	See Figure 3	50	ns

(1) Test conditions are C1–C4 = 0.1 µF at V_{CC} = 3.3 V ± 0.3 V; C1 = 0.047 µF, C2–C4 = 0.33 µF at V_{CC} = 5 V ± 0.5 V.

(2) All typical values are at V_{CC} = 3.3 V or V_{CC} = 5 V, and T_A = 25°C.

(3) Pulse skew is defined as |t_{PLH} - t_{PHL}| of each channel of the same device.

AUTO-POWERDOWN SECTION

Electrical Characteristics

over recommended ranges of supply voltage and operating free-air temperature (unless otherwise noted) (see [Figure 5](#))

PARAMETER		TEST CONDITIONS		MIN	MAX	UNIT
$V_{T+(valid)}$	Receiver input threshold for $\overline{INVALID}$ high-level output voltage	FORCEON = GND,	$\overline{FORCEOFF} = V_{CC}$		2.7	V
$V_{T-(valid)}$	Receiver input threshold for $\overline{INVALID}$ high-level output voltage	FORCEON = GND,	$\overline{FORCEOFF} = V_{CC}$	-2.7		V
$V_{T(invalid)}$	Receiver input threshold for $\overline{INVALID}$ low-level output voltage	FORCEON = GND,	$\overline{FORCEOFF} = V_{CC}$	-0.3	0.3	V
V_{OH}	$\overline{INVALID}$ high-level output voltage	$I_{OH} = 1\text{ mA}$, $\overline{FORCEOFF} = V_{CC}$	FORCEON = GND,	$V_{CC} - 0.6$		V
V_{OL}	$\overline{INVALID}$ low-level output voltage	$I_{OL} = 1.6\text{ mA}$, $\overline{FORCEOFF} = V_{CC}$	FORCEON = GND,		0.4	V

Switching Characteristics

over recommended ranges of supply voltage and operating free-air temperature (unless otherwise noted) (see [Figure 5](#))

PARAMETER		TYP ⁽¹⁾	UNIT
t_{valid}	Propagation delay time, low- to high-level output	1	μs
$t_{invalid}$	Propagation delay time, high- to low-level output	30	μs
t_{en}	Supply enable time	100	μs

(1) All typical values are at $V_{CC} = 3.3\text{ V}$ or $V_{CC} = 5\text{ V}$, and $T_A = 25^\circ\text{C}$.

PARAMETER MEASUREMENT INFORMATION

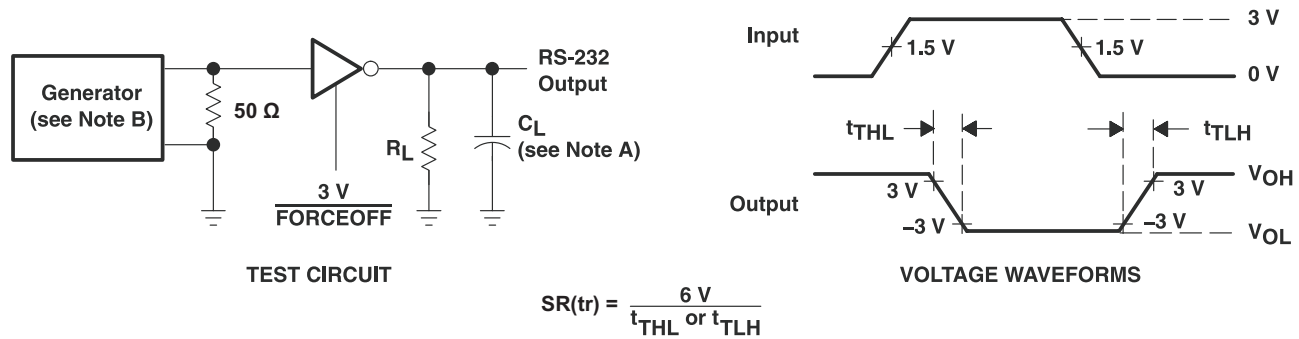

- A. C_L includes probe and jig capacitance.
- B. The pulse generator has the following characteristics: PRR = 250 kbits/s, $Z_O = 50\ \Omega$, 50% duty cycle, $t_r \leq 10\text{ ns}$, $t_f \leq 10\text{ ns}$.

Figure 1. Driver Slew Rate

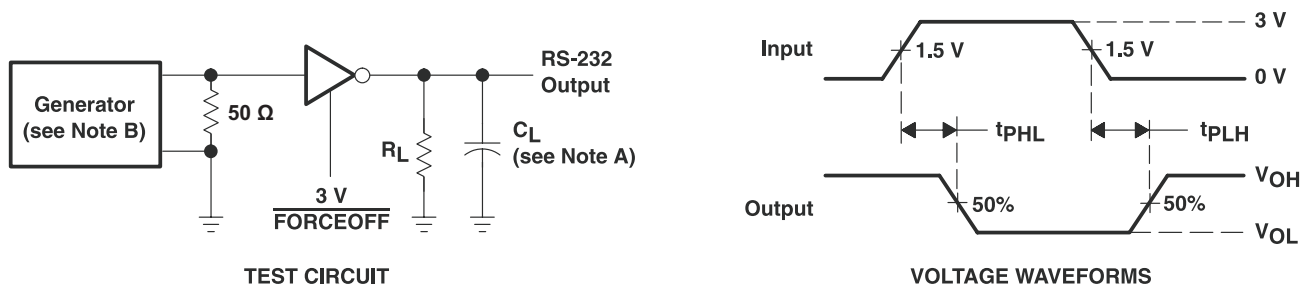

- A. C_L includes probe and jig capacitance.
- B. The pulse generator has the following characteristics: PRR = 250 kbits/s, $Z_O = 50\ \Omega$, 50% duty cycle, $t_r \leq 10\text{ ns}$, $t_f \leq 10\text{ ns}$.

Figure 2. Driver Pulse Skew

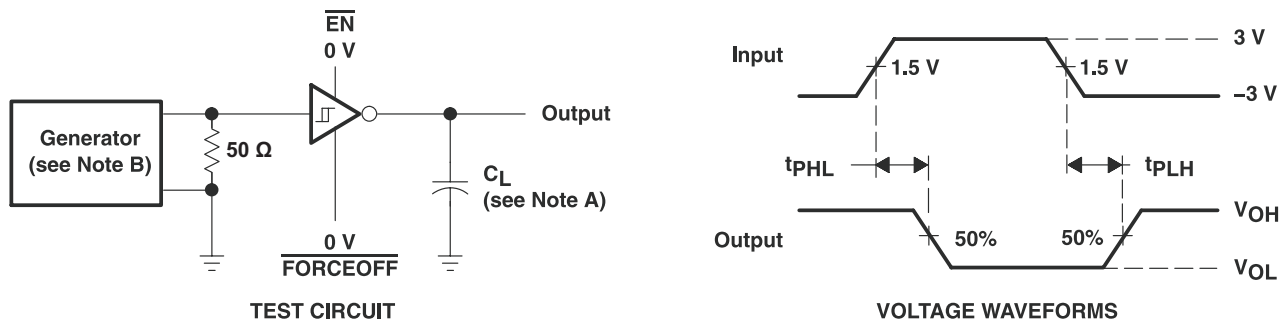

- A. C_L includes probe and jig capacitance.
- B. The pulse generator has the following characteristics: $Z_O = 50\ \Omega$, 50% duty cycle, $t_r \leq 10\text{ ns}$, $t_f \leq 10\text{ ns}$.

Figure 3. Receiver Propagation Delay Times

PARAMETER MEASUREMENT INFORMATION (continued)

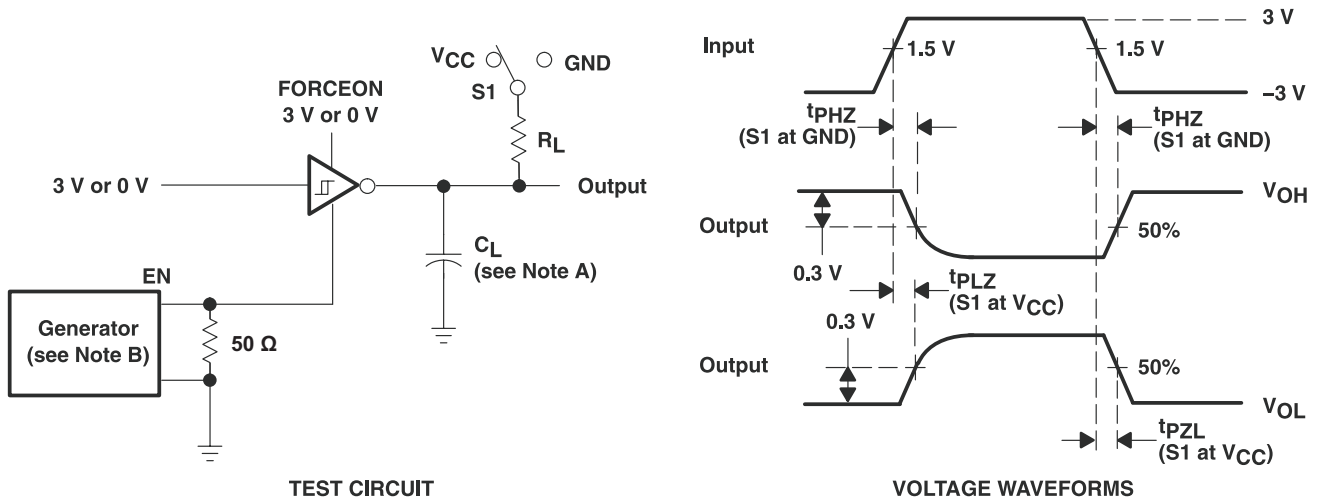

- A. C_L includes probe and jig capacitance.
- B. The pulse generator has the following characteristics: $Z_O = 50 \Omega$, 50% duty cycle, $t_r \leq 10 \text{ ns}$, $t_f \leq 10 \text{ ns}$.

Figure 4. Receiver Enable and Disable Times

PARAMETER MEASUREMENT INFORMATION (continued)

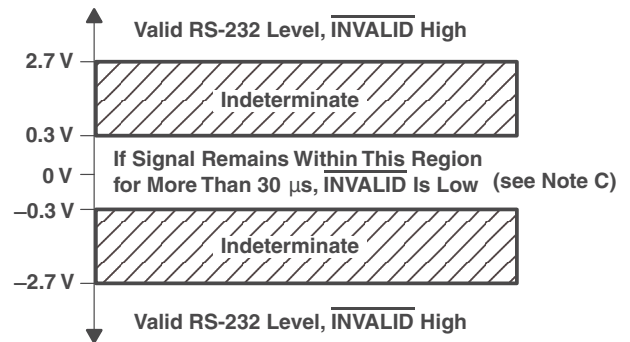
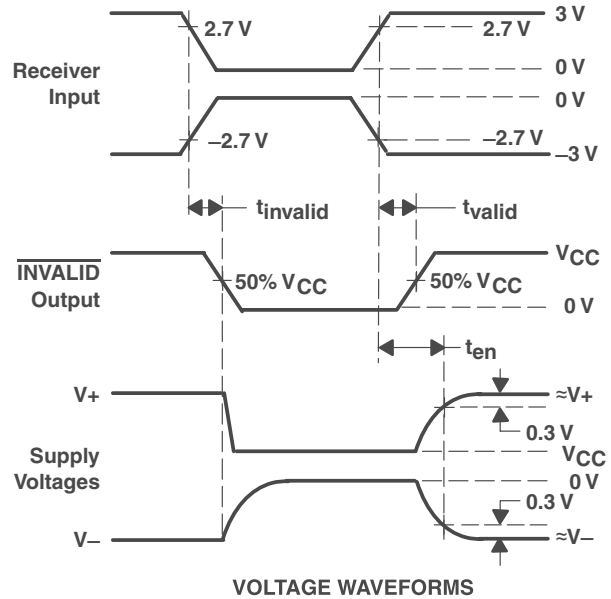
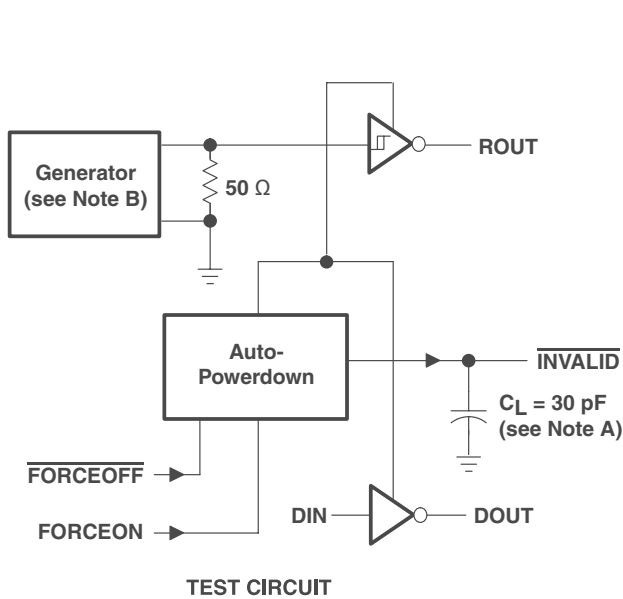

- A. C_L includes probe and jig capacitance.
- B. The pulse generator has the following characteristics: PRR = 5 kbits/s, $Z_O = 50 \Omega$, 50% duty cycle, $t_r \leq 10$ ns, $t_f \leq 10$ ns.
- C. Auto-powerdown disables drivers and reduces supply current to 1 μ A.

Figure 5. $\overline{\text{INVALID}}$ Propagation Delay Times and Supply Enabling Time

APPLICATION INFORMATION

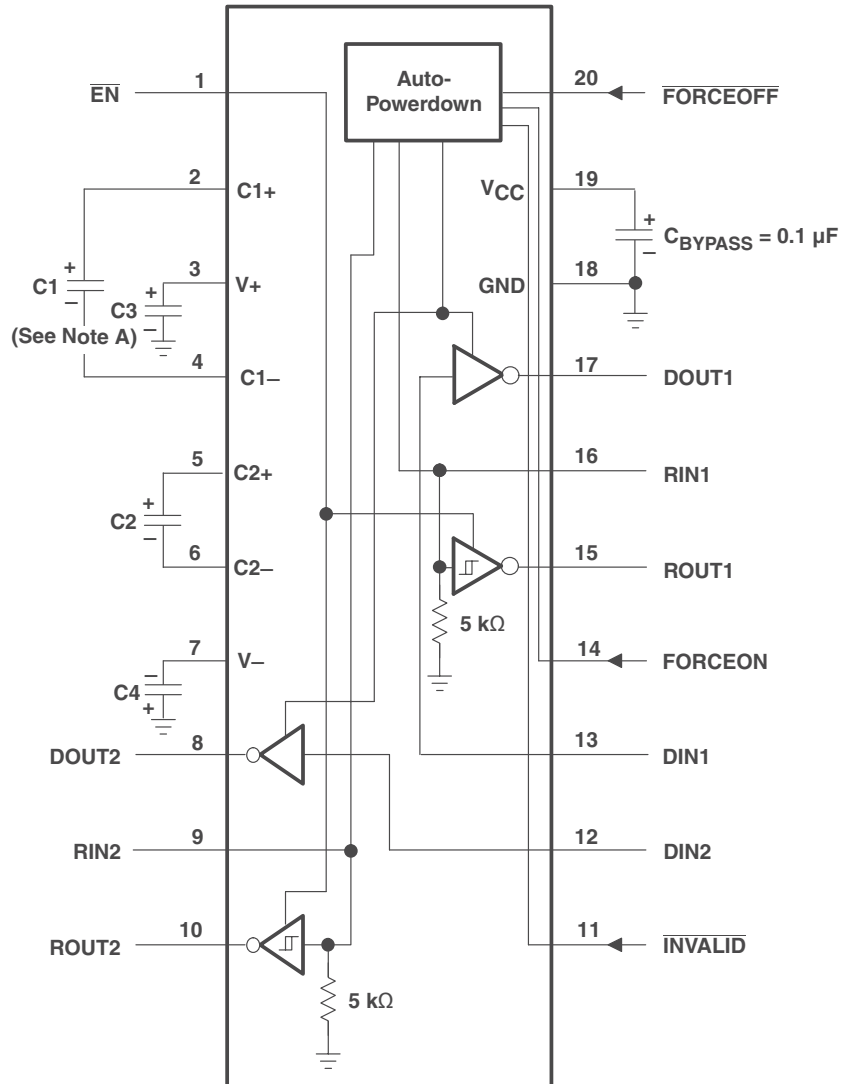

V_{CC} vs CAPACITOR VALUES

V _{CC}	C1	C2, C3, C4
3.3 V ± 0.3 V	0.1 µF	0.1 µF
5 V ± 0.5 V	0.047 µF	0.33 µF
3 V to 5.5 V	0.1 µF	0.47 µF

- A. C3 can be connected to V_{CC} or GND.
- B. Resistor values shown are nominal.

Figure 6. Typical Operating Circuit and Capacitor Values

PACKAGING INFORMATION

Orderable Device	Status ⁽¹⁾	Package Type	Package Drawing	Pins	Package Qty	Eco Plan ⁽²⁾	Lead/ Ball Finish	MSL Peak Temp ⁽³⁾	Samples (Requires Login)
TRSF3223CDB	ACTIVE	SSOP	DB	20		TBD	Call TI	Call TI	Purchase Samples
TRSF3223CDBG4	ACTIVE	SSOP	DB	20		TBD	Call TI	Call TI	Purchase Samples
TRSF3223CDBR	ACTIVE	SSOP	DB	20		TBD	Call TI	Call TI	Purchase Samples
TRSF3223CDBRG4	ACTIVE	SSOP	DB	20		TBD	Call TI	Call TI	Purchase Samples
TRSF3223CDW	ACTIVE	SOIC	DW	20		TBD	Call TI	Call TI	Purchase Samples
TRSF3223CDWG4	ACTIVE	SOIC	DW	20		TBD	Call TI	Call TI	Purchase Samples
TRSF3223CDWR	ACTIVE	SOIC	DW	20		TBD	Call TI	Call TI	Purchase Samples
TRSF3223CDWRG4	ACTIVE	SOIC	DW	20		TBD	Call TI	Call TI	Purchase Samples
TRSF3223CPW	ACTIVE	TSSOP	PW	20		TBD	Call TI	Call TI	Purchase Samples
TRSF3223CPWG4	ACTIVE	TSSOP	PW	20		TBD	Call TI	Call TI	Purchase Samples
TRSF3223CPWR	ACTIVE	TSSOP	PW	20		TBD	Call TI	Call TI	Purchase Samples
TRSF3223CPWRG4	ACTIVE	TSSOP	PW	20		TBD	Call TI	Call TI	Purchase Samples
TRSF3223IDB	ACTIVE	SSOP	DB	20		TBD	Call TI	Call TI	Purchase Samples
TRSF3223IDBG4	ACTIVE	SSOP	DB	20		TBD	Call TI	Call TI	Purchase Samples
TRSF3223IDBR	ACTIVE	SSOP	DB	20		TBD	Call TI	Call TI	Purchase Samples
TRSF3223IDBRG4	ACTIVE	SSOP	DB	20		TBD	Call TI	Call TI	Purchase Samples
TRSF3223IDW	ACTIVE	SOIC	DW	20		TBD	Call TI	Call TI	Purchase Samples
TRSF3223IDWG4	ACTIVE	SOIC	DW	20		TBD	Call TI	Call TI	Purchase Samples
TRSF3223IDWR	ACTIVE	SOIC	DW	20		TBD	Call TI	Call TI	Purchase Samples
TRSF3223IDWRG4	ACTIVE	SOIC	DW	20		TBD	Call TI	Call TI	Purchase Samples
TRSF3223IPW	ACTIVE	TSSOP	PW	20		TBD	Call TI	Call TI	Purchase Samples
TRSF3223IPWG4	ACTIVE	TSSOP	PW	20		TBD	Call TI	Call TI	Purchase Samples
TRSF3223IPWR	ACTIVE	TSSOP	PW	20		TBD	Call TI	Call TI	Purchase Samples
TRSF3223IPWRG4	ACTIVE	TSSOP	PW	20		TBD	Call TI	Call TI	Purchase Samples

⁽¹⁾ The marketing status values are defined as follows:

ACTIVE: Product device recommended for new designs.

LIFEBUY: TI has announced that the device will be discontinued, and a lifetime-buy period is in effect.

NRND: Not recommended for new designs. Device is in production to support existing customers, but TI does not recommend using this part in a new design.

PREVIEW: Device has been announced but is not in production. Samples may or may not be available.

OBSOLETE: TI has discontinued the production of the device.

⁽²⁾ Eco Plan - The planned eco-friendly classification: Pb-Free (RoHS), Pb-Free (RoHS Exempt), or Green (RoHS & no Sb/Br) - please check <http://www.ti.com/productcontent> for the latest availability information and additional product content details.

TBD: The Pb-Free/Green conversion plan has not been defined.

Pb-Free (RoHS): TI's terms "Lead-Free" or "Pb-Free" mean semiconductor products that are compatible with the current RoHS requirements for all 6 substances, including the requirement that lead not exceed 0.1% by weight in homogeneous materials. Where designed to be soldered at high temperatures, TI Pb-Free products are suitable for use in specified lead-free processes.

Pb-Free (RoHS Exempt): This component has a RoHS exemption for either 1) lead-based flip-chip solder bumps used between the die and package, or 2) lead-based die adhesive used between the die and leadframe. The component is otherwise considered Pb-Free (RoHS compatible) as defined above.

Green (RoHS & no Sb/Br): TI defines "Green" to mean Pb-Free (RoHS compatible), and free of Bromine (Br) and Antimony (Sb) based flame retardants (Br or Sb do not exceed 0.1% by weight in homogeneous material)

⁽³⁾ MSL, Peak Temp. -- The Moisture Sensitivity Level rating according to the JEDEC industry standard classifications, and peak solder temperature.

Important Information and Disclaimer: The information provided on this page represents TI's knowledge and belief as of the date that it is provided. TI bases its knowledge and belief on information provided by third parties, and makes no representation or warranty as to the accuracy of such information. Efforts are underway to better integrate information from third parties. TI has taken and continues to take reasonable steps to provide representative and accurate information but may not have conducted destructive testing or chemical analysis on incoming materials and chemicals. TI and TI suppliers consider certain information to be proprietary, and thus CAS numbers and other limited information may not be available for release.

In no event shall TI's liability arising out of such information exceed the total purchase price of the TI part(s) at issue in this document sold by TI to Customer on an annual basis.

DW (R-PDSO-G20)

PLASTIC SMALL-OUTLINE PACKAGE



- NOTES:
- A. All linear dimensions are in inches (millimeters).
 - B. This drawing is subject to change without notice.
 - C. Body dimensions do not include mold flash or protrusion not to exceed 0.006 (0,15).
 - D. Falls within JEDEC MS-013 variation AC.

DB (R-PDSO-G**)

PLASTIC SMALL-OUTLINE

28 PINS SHOWN



- NOTES: A. All linear dimensions are in millimeters.
 B. This drawing is subject to change without notice.
 C. Body dimensions do not include mold flash or protrusion not to exceed 0,15.
 D. Falls within JEDEC MO-150

PW (R-PDSO-G**)

PLASTIC SMALL-OUTLINE PACKAGE

14 PINS SHOWN



4040064/F 01/97

- NOTES: A. All linear dimensions are in millimeters.
 B. This drawing is subject to change without notice.
 C. Body dimensions do not include mold flash or protrusion not to exceed 0,15.
 D. Falls within JEDEC MO-153

IMPORTANT NOTICE

Texas Instruments Incorporated and its subsidiaries (TI) reserve the right to make corrections, modifications, enhancements, improvements, and other changes to its products and services at any time and to discontinue any product or service without notice. Customers should obtain the latest relevant information before placing orders and should verify that such information is current and complete. All products are sold subject to TI's terms and conditions of sale supplied at the time of order acknowledgment.

TI warrants performance of its hardware products to the specifications applicable at the time of sale in accordance with TI's standard warranty. Testing and other quality control techniques are used to the extent TI deems necessary to support this warranty. Except where mandated by government requirements, testing of all parameters of each product is not necessarily performed.

TI assumes no liability for applications assistance or customer product design. Customers are responsible for their products and applications using TI components. To minimize the risks associated with customer products and applications, customers should provide adequate design and operating safeguards.

TI does not warrant or represent that any license, either express or implied, is granted under any TI patent right, copyright, mask work right, or other TI intellectual property right relating to any combination, machine, or process in which TI products or services are used. Information published by TI regarding third-party products or services does not constitute a license from TI to use such products or services or a warranty or endorsement thereof. Use of such information may require a license from a third party under the patents or other intellectual property of the third party, or a license from TI under the patents or other intellectual property of TI.

Reproduction of TI information in TI data books or data sheets is permissible only if reproduction is without alteration and is accompanied by all associated warranties, conditions, limitations, and notices. Reproduction of this information with alteration is an unfair and deceptive business practice. TI is not responsible or liable for such altered documentation. Information of third parties may be subject to additional restrictions.

Resale of TI products or services with statements different from or beyond the parameters stated by TI for that product or service voids all express and any implied warranties for the associated TI product or service and is an unfair and deceptive business practice. TI is not responsible or liable for any such statements.

TI products are not authorized for use in safety-critical applications (such as life support) where a failure of the TI product would reasonably be expected to cause severe personal injury or death, unless officers of the parties have executed an agreement specifically governing such use. Buyers represent that they have all necessary expertise in the safety and regulatory ramifications of their applications, and acknowledge and agree that they are solely responsible for all legal, regulatory and safety-related requirements concerning their products and any use of TI products in such safety-critical applications, notwithstanding any applications-related information or support that may be provided by TI. Further, Buyers must fully indemnify TI and its representatives against any damages arising out of the use of TI products in such safety-critical applications.

TI products are neither designed nor intended for use in military/aerospace applications or environments unless the TI products are specifically designated by TI as military-grade or "enhanced plastic." Only products designated by TI as military-grade meet military specifications. Buyers acknowledge and agree that any such use of TI products which TI has not designated as military-grade is solely at the Buyer's risk, and that they are solely responsible for compliance with all legal and regulatory requirements in connection with such use.

TI products are neither designed nor intended for use in automotive applications or environments unless the specific TI products are designated by TI as compliant with ISO/TS 16949 requirements. Buyers acknowledge and agree that, if they use any non-designated products in automotive applications, TI will not be responsible for any failure to meet such requirements.

Following are URLs where you can obtain information on other Texas Instruments products and application solutions:

Products		Applications	
Amplifiers	amplifier.ti.com	Audio	www.ti.com/audio
Data Converters	dataconverter.ti.com	Automotive	www.ti.com/automotive
DLP® Products	www.dlp.com	Communications and Telecom	www.ti.com/communications
DSP	dsp.ti.com	Computers and Peripherals	www.ti.com/computers
Clocks and Timers	www.ti.com/clocks	Consumer Electronics	www.ti.com/consumer-apps
Interface	interface.ti.com	Energy	www.ti.com/energy
Logic	logic.ti.com	Industrial	www.ti.com/industrial
Power Mgmt	power.ti.com	Medical	www.ti.com/medical
Microcontrollers	microcontroller.ti.com	Security	www.ti.com/security
RFID	www.ti-rfid.com	Space, Avionics & Defense	www.ti.com/space-avionics-defense
RF/IF and ZigBee® Solutions	www.ti.com/lprf	Video and Imaging	www.ti.com/video
		Wireless	www.ti.com/wireless-apps

Mailing Address: Texas Instruments, Post Office Box 655303, Dallas, Texas 75265
Copyright © 2010, Texas Instruments Incorporated

Looking for pricing, stock, or lifecycle information?

Click below to explore more details on WIN SOURCE:

 [View TRSF3223CDWR](#) on WIN SOURCE

 [Texas Instruments](#) Information

Optimize Your Supply Chain with WIN SOURCE Solutions

-  Global Sourcing Solution
-  Obsolete Management
-  Cost Control Management
-  Shortage Management
-  Alternative Solution
-  Excess Inventory Management