



**THE DATASHEET OF
MB91F469QAHPB-GSK6E1**



32-bit Microcontroller

CMOS

FR60 MB91460Q Series

MB91F469QA

Differences versus MB91F469GB are marked in red color.

■ DESCRIPTION

MB91460Q series is a line of general-purpose 32-bit RISC microcontrollers designed for embedded control applications which require high-speed real-time processing, such as consumer devices and on-board vehicle systems. This series uses the FR60 CPU, which is compatible with the FR family* of CPUs.

This series contains the LIN-USART and CAN controllers.

* : FR, the abbreviation of FUJITSU RISC controller, is a line of products of FUJITSU Semiconductor Limited.

■ FEATURES

1. FR60 CPU core

- 32-bit RISC, load/store architecture, five-stage pipeline
- 16-bit fixed-length instructions (basic instructions)
- Instruction execution speed: 1 instruction per cycle
- Instructions including memory-to-memory transfer, bit manipulation, and barrel shift instructions: Instructions suitable for embedded applications
- Function entry/exit instructions and register data multi-load store instructions : Instructions supporting C language
- Register interlock function: Facilitating assembly-language coding
- Built-in multiplier with instruction-level support
 - Signed 32-bit multiplication : 5 cycles
 - Signed 16-bit multiplication : 3 cycles
- Interrupts (save PC/PS) : 6 cycles (16 priority levels)
- Harvard architecture enabling program access and data access to be performed simultaneously

For the information for microcontroller supports, see the following web site.

This web site includes the "**Customer Design Review Supplement**" which provides the latest cautions on system development and the minimal requirements to be checked to prevent problems before the system development.

<http://edevise.fujitsu.com/micom/en-support/>

MB91460Q Series

- Instructions compatible with the FR family

2. Internal peripheral resources

- General-purpose ports : Maximum 205 ports
- DMAC (DMA Controller)
 - Maximum of 5 channels able to operate simultaneously (including 2 external channels).
 - 3 transfer sources (external pin/internal peripheral/software)
 - Activation source can be selected using software
 - Addressing mode specifies full 32-bit addresses (increment/decrement/fixed)
 - Transfer mode (demand transfer/burst transfer/step transfer/block transfer)
 - Fly-by transfer support (between external I/O and memory)
 - Transfer data size selectable from 8/16/32-bit
 - Multi-byte transfer enabled (by software)
 - DMAC descriptor in I/O areas (200_H to 240_H, 1000_H to 1024_H)
- A/D converter (successive approximation type): **2 modules**
 - ADC 0: 10-bit resolution: 32 channels
 - ADC 1: 10-bit resolution: 8 channels**
 - Conversion time: minimum 1 μs
- External interrupt inputs : **32 channels**
 - 12 channels shared with CAN RX, **LIN-USART SIN**, I²C SDA or I²C SCL pins
 - 16 channels shared with ADC input pins**
- Bit search module (for REALOS)
 - Function to search from the MSB (most significant bit) for the position of the first “0”, “1”, or changed bit in a word
- LIN-USART (full duplex double buffer): **12 channels**, **8 channels** with FIFO
 - Clock synchronous/asynchronous selectable
 - Sync-break detection
 - Internal dedicated baud rate generator
 - LIN-USART 8-11 with asynchronous operation only**
- I²C bus interface (supports 400 kbps): **3 channel**
 - Master/slave transmission and reception
 - Arbitration function, clock synchronization function
- CAN controller (C-CAN): **3 channels**
 - Maximum transfer speed: 1 Mbps
 - 32 transmission/reception message buffers**
- Sound generator : 1 channelTone frequency : PWM frequency divide-by-two (reload value + 1)
- Alarm comparator : 2 channelsMonitor external voltageGenerate an interrupt in case of voltage lower/higher than the defined thresholds (reference voltage)
- 16-bit PPG timer : 16 channels
- 16-bit PFM timer : 1 channel
- 16-bit reload timer: 8 channels
- 16-bit free-run timer: **9 channels** (1 channel each for ICU and OCU)
- Input capture: **10 channels** (operates in conjunction with the free-run timer)
- Output compare: 8 channels (operates in conjunction with the free-run timer)
- Up/Down counter: 4 channels (4*8-bit or 2*16-bit)
- Watchdog timer
- Real-time clock

(Continued)

(Continued)

- Low-power consumption modes : Sleep/stop mode function
- Supply Supervisor: Low voltage detection circuit for external V_{DD5} and internal 1.8V core voltage
- Clock supervisor
Monitors the sub-clock (32 kHz) and the main clock (4 MHz) , and switches to a recovery clock (CR oscillator, etc.) when the oscillations stop.
- Clock modulator
- Clock monitor
- Sub-clock calibration
Corrects the real-time clock timer when operating with the 32 kHz or CR oscillator
- Main oscillator stabilization timer
Generates an interrupt in sub-clock mode after the stabilization wait time has elapsed on the 23-bit stabilization wait time counter
- Sub-oscillator stabilization timer
Generates an interrupt in main clock mode after the stabilization wait time has elapsed on the 15-bit stabilization wait time counter

3. Package and technology

- Package : 320-pin plastic BGA (BGA-320)
- CMOS 0.18 μm technology
- Power supply range 3 V to 5 V (1.8 V internal logic provided by a step-down voltage converter)
- Operating temperature range: between $-40\text{ }^{\circ}\text{C}$ and $+105\text{ }^{\circ}\text{C}$ / $+125\text{ }^{\circ}\text{C}$ *1

1. For maximum ambient temperature $T_{A(\text{max})}$, please refer to [ORDERING INFORMATION](#) on page 152.

MB91460Q Series

■ PRODUCT LINEUP

Feature	Evaluation devices		MB91F469QA
	MB91V460A	MB91FV460B	
Max. core frequency (CLKB)	80MHz	100MHz	100MHz at 1.9V ¹ 88MHz at 1.8V ²
Max. resource frequency (CLKP)	40MHz	50MHz	50MHz
Max. external bus freq. (CLKT)	40MHz	50MHz	50MHz
Max. CAN frequency (CLKCAN)	20MHz	50MHz	50MHz
Technology	0.35um	0.18μm	0.18μm
Flash memory	Emulation SRAM 32bit read data	2112 KByte or external emulation SRAM	2112 KByte
Flash Protection	no	yes	yes
Flash CRC calculation	no	yes	yes
D-RAM	64 KByte	64 KByte	64 KByte
ID-RAM	64 KByte	64 KByte	32 KByte
Flash-cache (F-cache)	16 KByte	16 KByte	16 KByte
External bus cache (I-cache)	4 KByte	4 KByte	4 KByte
Boot-ROM / BI-ROM	4 KByte fixed	16 KByte Boot Flash	4 KByte
MMU/MPU	MPU (16 ch) ³	MPU (16 ch) ³	MPU (8 ch) ³
DMA	5 ch	5 ch	5 ch
Software-Watchdog	yes	yes	yes
Hardware-Watchdog (RC osc. based)	yes (disengageable)	yes (disengageable), can be activated in SLEEP/ STOP	yes
Bit Search	yes	yes	yes
RTC	1 ch	1 ch	1 ch
Free Running Timer	8 ch	12 ch	9 ch
ICU	8 ch	10 ch	10 ch
OCU	8 ch	8 ch	8 ch
Reload Timer	8 ch	16 ch	8 ch
PPG 16-bit	16 ch	32 ch	16 ch
PFM 16-bit	1 ch	1 ch	1 ch
Sound Generator	1 ch	1 ch (old) + 1 ch (new)	1 ch
Up/Down Counter (8/16-bit)	4 ch (8-bit) / 2 ch (16-bit)	4 ch (8-bit) / 2 ch (16-bit)	4 ch (8-bit) / 2 ch (16-bit)
C_CAN	6 ch (128msg)	6 ch (128msg)	3 ch (32msg)
LIN-USART	4 ch + 4 ch FIFO + 8 ch	16 ch FIFO	4 ch + 4 ch FIFO + 4 ch FIFO (asynchronous)
I2C (400k)	4 ch	8 ch	3 ch

MB91460Q Series

Feature	Evaluation devices		MB91F469QA
	MB91V460A	MB91FV460B	
FR external bus	yes (32bit addr, 32bit data, 8 chip selects)	yes (32bit addr, 32bit data, 8 chip selects)	yes (28bit addr, 32bit data, 8 chip selects)
External Interrupts	16 ch	32 ch	32 ch
NMI Interrupts	1 ch	1 ch	-
General IO ports	288 (23 non-multiplexed)	328 (24 non-multiplexed)	205
ADC (10 bit)	32 ch	32 ch + 22 ch	32 ch + 8 ch
Alarm Comparator	2 ch	2 ch	2 ch
Reset input (INITX)	yes	yes	yes
Hardware Standby Input (HSTX)	yes	yes	no
Clock Modulator	yes	yes	yes
Low power mode	yes	yes	yes
Supply Supervisor	yes	yes	yes
Clock Supervisor	yes	yes	yes
Main clock oscillator	4MHz	4MHz	4MHz
Sub clock oscillator	32kHz	32kHz	32kHz
RC Oscillator	100kHz	100kHz / 2MHz	100kHz / 2MHz
PLL	x 20	x 25	x 25
DSU4	yes	yes	no
EDSU	yes (32 BP) ³	yes (32 BP) ³	yes (16 BP) ³
JTAG Boundary Scan	no	no	yes
Supply Voltage	3V / 5V	3V / 5V / 1.8V	3V / 5V
Regulator	yes	no	yes
Power Consumption	n.a.	n.a.	< 2 W
Temperature Range (T _A)	0..70 °C	0..70 °C	-40 °C .. T _{A(max)} ⁴
Package	BGA-660	BGA-896	BGA-320
Power on to PLL run	< 20 ms	< 20 ms	< 20 ms
Flash Download Time	n.a.	< 8 sec typical	< 8 sec typical

1. At 1.9V main regulator voltage. In order to enter this mode please set REGSEL_FLASHSEL=1 and REGSEL_MAINSEL=1.
2. At 1.8V main regulator voltage (default).
3. MPU channels use EDSU breakpoint registers (shared operation between MPU and EDSU).
4. For maximum ambient temperature T_{A(max)}, please refer to [ORDERING INFORMATION](#) on page 152

MB91460Q Series

■ PIN ASSIGNMENT

1. MB91F469QA

(TOP VIEW)

▲	1	2	3	4	5	6	7	8	9	10	11	12	13	14	15	16	17	18	19	20	
A	1	76	75	74	73	72	71	70	69	68	67	66	65	64	63	62	61	60	59	58	A
B	2	77	144	143	142	141	140	139	138	137	136	135	134	133	132	131	130	129	128	57	B
C	3	78	145	204	203	202	201	200	199	198	197	196	195	194	193	192	191	190	127	56	C
D	4	79	146	205	256	255	254	253	252	251	250	249	248	247	246	245	244	189	126	55	D
E	5	80	147	206													243	188	125	54	E
F	6	81	148	207													242	187	124	53	F
G	7	82	149	208			257	284	283	282	281	280	279	278			241	186	123	52	G
H	8	83	150	209			258	285	304	303	302	301	300	277			240	185	122	51	H
J	9	84	151	210			259	286	305	316	315	314	299	276			239	184	121	50	J
K	10	85	152	211			260	287	306	317	320	313	298	275			238	183	120	49	K
L	11	86	153	212			261	288	307	318	319	312	297	274			237	182	119	48	L
M	12	87	154	213			262	289	308	309	310	311	296	273			236	181	118	47	M
N	13	88	155	214			263	290	291	292	293	294	295	272			235	180	117	46	N
P	14	89	156	215			264	265	266	267	268	269	270	271			234	179	116	45	P
R	15	90	157	216													233	178	115	44	R
T	16	91	158	217													232	177	114	43	T
U	17	92	159	218	219	220	221	222	223	224	225	226	227	228	229	230	231	176	113	42	U
V	18	93	160	161	162	163	164	165	166	167	168	169	170	171	172	173	174	175	112	41	V
W	19	94	95	96	97	98	99	100	101	102	103	104	105	106	107	108	109	110	111	40	W
Y	20	21	22	23	24	25	26	27	28	29	30	31	32	33	34	35	36	37	38	39	Y
	1	2	3	4	5	6	7	8	9	10	11	12	13	14	15	16	17	18	19	20	

BGA-320P-M06

■ PIN DESCRIPTION

1. MB91F469QA :

JEDEC	Pin no.	Pin name	I/O	I/O circuit type ¹	Description
B1	2	P24_1	I/O	A	General-purpose input/output port
		INT1			External interrupt input pin
C1	3	P13_0	I/O	A	General-purpose input/output port
		DREQ0			DMA external transfer request input
D1	4	P13_1	I/O	A	General-purpose input/output port
		DACKX0			DMA external transfer acknowledge output pin
E1	5	P13_3	I/O	A	General-purpose input/output port
		DEOP0			DMA external transfer EOP (End of Process) output pin
F1	6	P13_6	I/O	A	General-purpose input/output port
		DEOTX1			DMA external transfer EOT (End of Track) output pin
		DEOP1			DMA external transfer EOP (End of Process) output pin
G1	7	P11_1	I/O	A	General-purpose input/output port
		IOWRX			DMA memory to I/O fly-by transfer output pin
H1	8	P09_3	I/O	A	General-purpose input/output port
		CSX3			Chip select output pin
J1	9	P09_6	I/O	A	General-purpose input/output port
		CSX6			Chip select output pin
K1	10	P08_2	I/O	A	General-purpose input/output port
		WRX2			External write strobe output pin
L1	11	P08_5	I/O	A	General-purpose input/output port
		BGRNTX			External bus release reception output pin
M1	12	P07_1	I/O	A	General-purpose input/output port
		A1			Signal pin of external address bus (bit1)
N1	13	P07_5	I/O	A	General-purpose input/output port
		A5			Signal pin of external address bus (bit5)
P1	14	P06_0	I/O	A	General-purpose input/output port
		A8			Signal pin of external address bus (bit8)
R1	15	P06_4	I/O	A	General-purpose input/output port
		A12			Signal pin of external address bus (bit12)
T1	16	P06_7	I/O	A	General-purpose input/output port
		A15			Signal pin of external address bus (bit15)
U1	17	P05_3	I/O	A	General-purpose input/output port
		A19			Signal pin of external address bus (bit19)

MB91460Q Series

JEDEC	Pin no.	Pin name	I/O	I/O circuit type ¹	Description
V1	18	P05_6	I/O	A	General-purpose input/output port
		A22			Signal pin of external address bus (bit22)
W1	19	P04_1	I/O	A	General-purpose input/output port
		A25			Signal pin of external address bus (bit25)
Y2	21	P04_3	I/O	A	General-purpose input/output port
		A27			Signal pin of external address bus (bit27)
Y3	22	P03_1	I/O	A	General-purpose input/output port
		D1			Signal pin of external data bus (bit1)
Y4	23	P03_4	I/O	A	General-purpose input/output port
		D4			Signal pin of external data bus (bit4)
Y5	24	P02_0	I/O	A	General-purpose input/output port
		D8			Signal pin of external data bus (bit8)
Y6	25	P02_3	I/O	A	General-purpose input/output port
		D11			Signal pin of external data bus (bit11)
Y7	26	P02_7	I/O	A	General-purpose input/output port
		D15			Signal pin of external data bus (bit15)
Y8	27	P01_2	I/O	A	General-purpose input/output port
		D18			Signal pin of external data bus (bit18)
Y9	28	P01_6	I/O	A	General-purpose input/output port
		D22			Signal pin of external data bus (bit22)
Y10	29	P00_1	I/O	A	General-purpose input/output port
		D25			Signal pin of external data bus (bit25)
Y11	30	P00_5	I/O	A	General-purpose input/output port
		D29			Signal pin of external data bus (bit29)
Y12	31	P00_6	I/O	A	General-purpose input/output port
		D30			Signal pin of external data bus (bit30)
Y13	32	P00_7	I/O	A	General-purpose input/output port
		D31			Signal pin of external data bus (bit31)
Y14	33	P10_4	I/O	A	General-purpose input/output port
		MCLKO			Clock output pin for memory
Y16	35	MONCLK	O	M	Clock monitor pin
W20	40	P21_0	I/O	A	General-purpose input/output port
		SIN0			Data input pin of USART0
V20	41	P21_4	I/O	A	General-purpose input/output port
		SIN1			Data input pin of USART1

MB91460Q Series

JEDEC	Pin no.	Pin name	I/O	I/O circuit type ¹	Description
U20	42	P20_0	I/O	A	General-purpose input/output port
		SIN2			Data input pin of USART2
		AIN0			Up/down counter input pin
T20	43	P20_4	I/O	A	General-purpose input/output port
		SIN3			Data input pin of USART3
		AIN1			Up/down counter input pin
R20	44	P19_0	I/O	A	General-purpose input/output port
		SIN4			Data input pin of USART4
P20	45	P19_2	I/O	A	General-purpose input/output port
		SCK4			Clock input/output pin of USART4
		CK4			External clock input pin of free-run timer 4
N20	46	X1	---	J1	Clock (oscillation) output
M20	47	P18_2	I/O	B	General-purpose input/output port
		SCK6			Clock input/output pin of USART6
		ZIN2			Up/down counter input pin
		CK6			External clock input pin of free-run timer 6
		AN42			Analog input pin of A/D converter (second A/D macro)
L20	48	P18_6	I/O	B	General-purpose input/output port
		SCK7			Clock input/output pin of USART7
		ZIN3			Up/down counter input pin
		CK7			External clock input pin of free-run timer 7
		AN46			Analog input pin of A/D converter (second A/D macro)
K20	49	P17_2	I/O	B	General-purpose input/output port
		PPG2			PPG timer output pins
		AN34			Analog input pin of A/D converter (second A/D macro)
J20	50	P17_6	I/O	B	General-purpose input/output port
		PPG6			PPG timer output pins
		AN38			Analog input pin of A/D converter (second A/D macro)
H20	51	P23_2	I/O	A	General-purpose input/output port
		RX1			RX input/output pin of CAN1
		INT9			External interrupt input pin
G20	52	P34_1	I/O	A	General-purpose input/output port
		SOT10			Data output of USART10
F20	53	P35_1	I/O	A	General-purpose input/output port
		SOT8			Data output of USART8

MB91460Q Series

JEDEC	Pin no.	Pin name	I/O	I/O circuit type ¹	Description
E20	54	P29_4	I/O	B	General-purpose input/output port
		AN4			Analog input pin of A/D converter
D20	55	P28_0	I/O	B	General-purpose input/output port
		AN8			Analog input pin of A/D converter
C20	56	P28_3	I/O	B	General-purpose input/output port
		AN11			Analog input pin of A/D converter
B20	57	P28_5	I/O	B	General-purpose input/output port
		AN13			Analog input pin of A/D converter
A19	59	P28_7	I/O	B	General-purpose input/output port
		AN15			Analog input pin of A/D converter
A17	61	P27_2	I/O	B	General-purpose input/output port
		AN18			Analog input pin of A/D converter
		INT18			External interrupt pin
A14	64	P26_0	I/O	B	General-purpose input/output port
		AN24			Analog input pin of A/D converter
		INT24			External interrupt pin
A13	65	P35_4	I/O	A	General-purpose input/output port
		SIN9			Data input of USART9
		INT12			External interrupt input pin
A12	66	P35_5	I/O	A	General-purpose input/output port
		SOT9			Data output pin of USART9
A11	67	P22_3	I/O	A	General-purpose input/output port
		TX5			TX output pin of CAN5
A10	68	P22_6	I/O	C	General-purpose input/output port
		SDA1			I ² C bus data input/output pin (open drain)
		INT15			External interrupt input pin
		ICU8			Input capture input pin ²
A9	69	P14_2	I/O	A	General-purpose input/output port
		ICU2			Input capture input pin
		TIN2			External trigger input pin of reload timer
		TTG10/2			External trigger input pin of PPG timer
A8	70	P14_6	I/O	A	General-purpose input/output port
		ICU6			Input capture input pin
		TIN6			Input capture input pin
		TTG14/6			External trigger input pin of PPG timer

MB91460Q Series

JEDEC	Pin no.	Pin name	I/O	I/O circuit type ¹	Description
A7	71	P16_1	I/O	A	General-purpose input/output port
		PPG9			Output pin of PPG timer
A6	72	P16_5	I/O	A	General-purpose input/output port
		PPG13			Output pin of PPG timer
		SG0			SG0 output pin of sound generator
A5	73	P15_0	I/O	A	General-purpose input/output port
		OCU0			Output compare output pin
		TOT0			Reload timer output pin
A4	74	P15_4	I/O	A	General-purpose input/output port
		OCU4			Output compare output pin
		TOT4			Reload timer output pin
A3	75	P15_7	I/O	A	General-purpose input/output port
		OCU7			Output compare output pin
		TOT7			Reload timer output pin
A2	76	P24_0	I/O	A	General-purpose input/output port
		INT0			External interrupt input pin
B2	77	P24_2	I/O	A	General-purpose input/output port
		INT2			External interrupt input pin
C2	78	P34_4	I/O	A	General-purpose input/output port
		INT4			External interrupt input pin
		SIN11			Data input pin of USART11
D2	79	P13_2	I/O	A	General-purpose input/output port
		DEOTX0			DMA external transfer EOT (End of Track) output pin
		DEOP0			DMA external transfer EOP (End of Process) output pin
E2	80	P13_4	I/O	A	General-purpose input/output port
		DREQ1			DMA external transfer request input
F2	81	P13_7	I/O	A	General-purpose input/output port
		DEOP1			DMA external transfer EOP (End of Process) output pin
G2	82	P09_0	I/O	A	General-purpose input/output port
		CSX0			Chip select output pin
H2	83	P09_4	I/O	A	General-purpose input/output port
		CSX4			Chip select output pin
J2	84	P09_7	I/O	A	General-purpose input/output port
		CSX7			Chip select output pin
K2	85	P08_3	I/O	A	General-purpose input/output port
		WRX3			External write strobe output pin

MB91460Q Series

JEDEC	Pin no.	Pin name	I/O	I/O circuit type ¹	Description
L2	86	P08_6	I/O	A	General-purpose input/output port
		BRQ			External bus release request input pin
M2	87	P07_2	I/O	A	General-purpose input/output port
		A2			Signal pin of external address bus (bit2)
N2	88	P07_6	I/O	A	General-purpose input/output port
		A6			Signal pin of external address bus (bit6)
P2	89	P06_1	I/O	A	General-purpose input/output port
		A9			Signal pin of external address bus (bit9)
R2	90	P06_5	I/O	A	General-purpose input/output port
		A13			Signal pin of external address bus (bit13)
T2	91	P05_0	I/O	A	General-purpose input/output port
		A16			Signal pin of external address bus (bit16)
U2	92	P05_4	I/O	A	General-purpose input/output port
		A20			Signal pin of external address bus (bit20)
V2	93	P05_7	I/O	A	General-purpose input/output port
		A23			Signal pin of external address bus (bit23)
W2	94	P04_2	I/O	A	General-purpose input/output port
		A26			Signal pin of external address bus (bit26)
W3	95	P03_0	I/O	A	General-purpose input/output port
		D0			Signal pin of external data bus (bit0)
W4	96	P03_3	I/O	A	General-purpose input/output port
		D3			Signal pin of external data bus (bit3)
W5	97	P03_7	I/O	A	General-purpose input/output port
		D7			Signal pin of external data bus (bit7)
W6	98	P02_2	I/O	A	General-purpose input/output port
		D10			Signal pin of external data bus (bit10)
W7	99	P02_6	I/O	A	General-purpose input/output port
		D14			Signal pin of external data bus (bit14)
W8	100	P01_1	I/O	A	General-purpose input/output port
		D17			Signal pin of external data bus (bit17)
W9	101	P01_5	I/O	A	General-purpose input/output port
		D21			Signal pin of external data bus (bit21)
W10	102	P00_0	I/O	A	General-purpose input/output port
		D24			Signal pin of external data bus (bit24)
W11	103	P00_4	I/O	A	General-purpose input/output port
		D28			Signal pin of external data bus (bit28)

MB91460Q Series

JEDEC	Pin no.	Pin name	I/O	I/O circuit type ¹	Description
W12	104	P10_1	I/O	A	General-purpose input/output port
		ASX			Address strobe output pin
W13	105	P10_0	I/O	A	General-purpose input/output port
		SYSCLK			Clock output pin for external bus
W14	106	P10_5	I/O	A	General-purpose input/output port
		MCLKI			Clock input pin for memory
W15	107	TDO	O	M	Boundary Scan Test Data Out pin
W16	108	TDI	I	H	Boundary Scan Test Data In pin
W17	109	TRST	I	I	Boundary Scan Test Reset pin
W18	110	P21_2	I/O	A	General-purpose input/output port
		SCK0			Clock input/output pin of USART0
		CK0/8			External clock input pin of free-run timer 0 + 8
W19	111	P21_1	I/O	A	General-purpose input/output port
		SOT0			Data output pin of USART0
V19	112	P21_5	I/O	A	General-purpose input/output port
		SOT1			Data output pin of USART1
U19	113	P20_1	I/O	A	General-purpose input/output port
		SOT2			Data output pin of USART2
		BIN0			Up/down counter input pin
T19	114	X0A	---	J2	Sub clock (oscillation) input
R19	115	P19_1	I/O	A	General-purpose input/output port
		SOT4			Data output pin of USART4
P19	116	P19_4	I/O	A	General-purpose input/output port
		SIN5			Data input pin of USART5
N19	117	P18_0	I/O	A	General-purpose input/output port
		SIN6			Data input pin of USART6
		AIN2			Up/down counter input pin
M19	118	X0	---	J1	Clock (oscillation) input
L19	119	P17_0	I/O	A	General-purpose input/output port
		PPG0			Output pin of PPG timer
K19	120	P17_3	I/O	B	General-purpose input/output port
		PPG3			Output pin of PPG timer
		AN35			Analog input pin of A/D converter (second A/D macro)
J19	121	P17_7	I/O	B	General-purpose input/output port
		PPG7			Output pin of PPG timer
		AN39			Analog input pin of A/D converter (second A/D macro)

MB91460Q Series

JEDEC	Pin no.	Pin name	I/O	I/O circuit type ¹	Description
H19	122	P23_3	I/O	A	General-purpose input/output port
		TX1			TX output pin of CAN1
G19	123	P35_0	I/O	A	General-purpose input/output port
		SIN8			Data input of USART8
		INT11			External interrupt input pin
F19	124	P29_2	I/O	B	General-purpose input/output port
		AN2			Analog input pin of A/D converter
E19	125	P29_5	I/O	B	General-purpose input/output port
		AN5			Analog input pin of A/D converter
D19	126	P28_1	I/O	B	General-purpose input/output port
		AN9			Analog input pin of A/D converter
C19	127	P28_4	I/O	B	General-purpose input/output port
		AN12			Analog input pin of A/D converter
B19	128	P28_6	I/O	B	General-purpose input/output port
		AN14			Analog input pin of A/D converter
B18	129	P27_0	I/O	B	General-purpose input/output port
		AN16			Analog input pin of A/D converter
		INT16			External interrupt pin
B17	130	P27_3	I/O	B	General-purpose input/output port
		AN19			Analog input pin of A/D converter
		INT19			External interrupt pin
B16	131	P27_5	I/O	B	General-purpose input/output port
		AN21			Analog input pin of A/D converter
		INT21			External interrupt pin
B15	132	P27_7	I/O	B	General-purpose input/output port
		AN23			Analog input pin of A/D converter
		INT23			External interrupt pin
B14	133	P26_1	I/O	B	General-purpose input/output port
		AN25			Analog input pin of A/D converter
		INT25			External interrupt pin
B13	134	P26_4	I/O	B	General-purpose input/output port
		AN28			Analog input pin of A/D converter
		INT28			External interrupt pin
B12	135	P22_2	I/O	A	General-purpose input/output port
		RX5			RX input/output pin of CAN5
		INT13			External interrupt input pin

MB91460Q Series

JEDEC	Pin no.	Pin name	I/O	I/O circuit type ¹	Description
B11	136	P24_4	I/O	C	General-purpose input/output port
		SDA2			I ² C bus data input/output pin (open drain)
		INT14			External interrupt input pin
B10	137	P22_7	I/O	C	General-purpose input/output port
		SCL1			I ² C bus clock input/output pin (open drain)
		ICU9			Input capture input pin ³
B9	138	P14_3	I/O	A	General-purpose input/output port
		ICU3			Input capture input pin
		TIN3			External trigger input pin of reload timer
		TTG11/3			External trigger input pin of PPG timer
B8	139	P14_7	I/O	A	General-purpose input/output port
		ICU7			Input capture input pin
		TIN7			External trigger input pin of reload timer
		TTG15/7			External trigger input pin of PPG timer
B7	140	P16_2	I/O	A	General-purpose input/output port
		PPG10			Output pin of PPG timer
B6	141	P16_6	I/O	A	General-purpose input/output port
		PPG14			Output pin of PPG timer
		PFM			Pulse frequency modulator output pin
B5	142	P15_1	I/O	A	General-purpose input/output port
		OCU1			Output compare output pin
		TOT1			Reload timer output pin
B4	143	P15_5	I/O	A	General-purpose input/output port
		OCU5			Output compare output pin
		TOT5			Reload timer output pin
B3	144	P24_3	I/O	A	General-purpose input/output port
		INT3			External interrupt input pin
C3	145	P34_5	I/O	A	General-purpose input/output port
		INT5			External interrupt input pin
		SOT11			Data output pin of USART11
D3	146	P24_6	I/O	C	General-purpose input/output port
		INT6			External interrupt input pin
		SDA3			I ² C bus data input/output pin (open drain)
E3	147	P13_5	I/O	A	General-purpose input/output port
		DACKX1			DMA external transfer acknowledge output pin

MB91460Q Series

JEDEC	Pin no.	Pin name	I/O	I/O circuit type ¹	Description
F3	148	P11_0	I/O	A	General-purpose input/output port
		IORDX			Output pin for DMA I/O to memory fly-by transfer
G3	149	P09_1	I/O	A	General-purpose input/output port
		CSX1			Chip select output pin
H3	150	P09_5	I/O	A	General-purpose input/output port
		CSX5			Chip select output pin
J3	151	P08_0	I/O	A	General-purpose input/output port
		WRX0			External write strobe output pin
K3	152	P08_4	I/O	A	General-purpose input/output port
		RDX			External read strobe output pin
L3	153	P08_7	I/O	A	General-purpose input/output port
		RDY			External ready input pin
M3	154	P07_3	I/O	A	General-purpose input/output port
		A3			Signal pin of external address bus (bit3)
N3	155	P07_7	I/O	A	General-purpose input/output port
		A7			Signal pin of external address bus (bit7)
P3	156	P06_2	I/O	A	General-purpose input/output port
		A10			Signal pin of external address bus (bit10)
R3	157	P06_6	I/O	A	General-purpose input/output port
		A14			Signal pin of external address bus (bit14)
T3	158	P05_1	I/O	A	General-purpose input/output port
		A17			Signal pin of external address bus (bit17)
U3	159	P05_5	I/O	A	General-purpose input/output port
		A21			Signal pin of external address bus (bit21)
V3	160	P04_0	I/O	A	General-purpose input/output port
		A24			Signal pin of external address bus (bit24)
V4	161	P03_2	I/O	A	General-purpose input/output port
		D2			Signal pin of external data bus (bit2)
V5	162	P03_6	I/O	A	General-purpose input/output port
		D6			Signal pin of external data bus (bit6)
V6	163	P02_1	I/O	A	General-purpose input/output port
		D9			Signal pin of external data bus (bit9)
V7	164	P02_5	I/O	A	General-purpose input/output port
		D13			Signal pin of external data bus (bit13)
V8	165	P01_0	I/O	A	General-purpose input/output port
		D16			Signal pin of external data bus (bit16)

MB91460Q Series

JEDEC	Pin no.	Pin name	I/O	I/O circuit type ¹	Description
V9	166	P01_4	I/O	A	General-purpose input/output port
		D20			Signal pin of external data bus (bit20)
V10	167	P01_7	I/O	A	General-purpose input/output port
		D23			Signal pin of external data bus (bit23)
V11	168	P00_3	I/O	A	General-purpose input/output port
		D27			Signal pin of external data bus (bit27)
V12	169	P10_6	I/O	A	General-purpose input/output port
		MCLKE			Clock enable signal pin for memory
V13	170	P10_2	I/O	A	General-purpose input/output port
		BAAX			Burst address advance output pin
V14	171	TMS	I	H	Boundary Scan Test Mode Select pin
V15	172	MD_2	I	G	Mode setting pins
V16	173	MD_1	I	G	
V17	174	MD_0	I	G	
V18	175	P21_6	I/O	A	General-purpose input/output port
		SCK1			Clock input/output pin of USART1
		CK1			External clock input pin of free-run timer 1
U18	176	P20_2	I/O	A	General-purpose input/output port
		SCK2			Clock input/output pin of USART2
		ZIN0			Up/down counter input pin
		CK2			External clock input pin of free-run timer 2
T18	177	P20_5	I/O	A	General-purpose input/output port
		SOT3			Data output pin of USART3
		BIN1			Up/down counter input pin
R18	178	X1A	---	J2	Sub clock (oscillation) output
P18	179	P19_5	I/O	A	General-purpose input/output port
		SOT5			Data output pin of USART2
N18	180	P18_1	I/O	A	General-purpose input/output port
		SOT6			Data output pin of USART6
		BIN2			Up/down counter input pin
M18	181	P18_4	I/O	A	General-purpose input/output port
		SIN7			Data input pin of USART7
		AIN3			Up/down counter input pin
L18	182	P17_1	I/O	A	General-purpose input/output port
		PPG1			PPG timer output pin

MB91460Q Series

JEDEC	Pin no.	Pin name	I/O	I/O circuit type ¹	Description
K18	183	P17_4	I/O	B	General-purpose input/output port
		PPG4			PPG timer output pin
		AN36			Analog input pin of A/D converter (second A/D macro)
J18	184	P23_0	I/O	A	General-purpose input/output port
		RX0			RX input/output pin of CAN0
		INT8			External interrupt input pin
H18	185	P34_0	I/O	A	General-purpose input/output port
		SIN10			Data input of USART10
		INT10			External interrupt input pin
G18	186	P29_0	I/O	B	General-purpose input/output port
		AN0			Analog input pin of A/D converter
F18	187	P29_3	I/O	B	General-purpose input/output port
		AN3			Analog input pin of A/D converter
E18	188	P29_6	I/O	B	General-purpose input/output port
		AN6			Analog input pin of A/D converter
D18	189	P28_2	I/O	B	General-purpose input/output port
		AN10			Analog input pin of A/D converter
C18	190	P27_1	I/O	B	General-purpose input/output port
		AN17			Analog input pin of A/D converter
		INT17			External interrupt pin
C17	191	P27_4	I/O	B	General-purpose input/output port
		AN20			Analog input pin of A/D converter
		INT20			External interrupt pin
C16	192	ALARM_0	I	N	Alarm comparator input pin
C15	193	ALARM_1	I	N	Alarm comparator input pin
C14	194	P26_2	I/O	B	General-purpose input/output port
		AN26			Analog input pin of A/D converter
		INT26			External interrupt pin
C13	195	P26_5	I/O	B	General-purpose input/output port
		AN29			Analog input pin of A/D converter
		INT29			External interrupt pin
C12	196	P26_6	I/O	B	General-purpose input/output port
		AN30			Analog input pin of A/D converter
		INT30			External interrupt pin
C11	197	P24_5	I/O	C	General-purpose input/output port
		SCL2			I ² C bus clock input/output pin (open drain)

MB91460Q Series

JEDEC	Pin no.	Pin name	I/O	I/O circuit type ¹	Description
C10	198	P14_0	I/O	A	General-purpose input/output port
		ICU0			Input capture input pin
		TIN0			External trigger input pin of reload timer
		TTG8/0			External trigger input pin of PPG timer
C9	199	P14_4	I/O	A	General-purpose input/output port
		ICU4			Input capture input pin
		TIN4			External trigger input pin of reload timer
		TTG12/4			External trigger input pin of PPG timer
C8	200	P16_0	I/O	A	General-purpose input/output port
		PPG8			Output pin of PPG timer
C7	201	P16_3	I/O	A	General-purpose input/output port
		PPG11			Output pin of PPG timer
C6	202	P16_7	I/O	A	General-purpose input/output port
		PPG15			Output pin of PPG timer
		ATGX			A/D converter external trigger input pin
C5	203	P15_2	I/O	A	General-purpose input/output port
		OCU2			Output compare output pin
		TOT2			Reload timer output pin
C4	204	P15_6	I/O	A	General-purpose input/output port
		OCU6			Output compare output pin
		TOT6			Reload timer output pin
E4	206	P24_7	I/O	C	General-purpose input/output port
		INT7			External interrupt input pin
		SCL3			I ² C bus clock input/output pin (open drain)
G4	208	P09_2	I/O	A	General-purpose input/output port
		CSX2			Chip select output pin
J4	210	P08_1	I/O	A	General-purpose input/output port
		WRX1			External write strobe output pin
L4	212	P07_0	I/O	A	General-purpose input/output port
		A0			Signal pin of external address bus (bit0)
M4	213	P07_4	I/O	A	General-purpose input/output port
		A4			Signal pin of external address bus (bit4)
P4	215	P06_3	I/O	A	General-purpose input/output port
		A11			Signal pin of external address bus (bit11)
T4	217	P05_2	I/O	A	General-purpose input/output port
		A18			Signal pin of external address bus (bit18)

MB91460Q Series

JEDEC	Pin no.	Pin name	I/O	I/O circuit type ¹	Description
U5	219	P03_5	I/O	A	General-purpose input/output port
		D5			Signal pin of external data bus (bit5)
U7	221	P02_4	I/O	A	General-purpose input/output port
		D12			Signal pin of external data bus (bit12)
U9	223	P01_3	I/O	A	General-purpose input/output port
		D19			Signal pin of external data bus (bit19)
U11	225	P00_2	I/O	A	General-purpose input/output port
		D26			Signal pin of external data bus (bit26)
U12	226	P10_3	I/O	A	General-purpose input/output port
		WEX			Write enable output pin
U14	228	TCK	I	I	Boundary Scan Test Clock input pin
U16	230	INITX	I	H	External reset input pin
T17	232	P20_6	I/O	A	General-purpose input/output port
		SCK3			Clock input/output pin of USART3
		ZIN1			Up/down counter input pin
		CK3			External clock input pin of free-run timer 3
P17	234	P19_6	I/O	A	General-purpose input/output port
		SCK5			Clock input/output pin of USART5
		CK5			External clock input pin of free-run timer 5
M17	236	P18_5	I/O	A	General-purpose input/output port
		SOT7			Data output pin of USART7
		BIN3			Up/down counter input pin
K17	238	P17_5	I/O	B	General-purpose input/output port
		PPG5			Output pin of PPG timer
		AN37			Analog input pin of A/D converter (second A/D macro)
J17	239	P23_1	I/O	A	General-purpose input/output port
		TX0			TX output pin of CAN0
G17	241	P29_1	I/O	B	General-purpose input/output port
		AN1			Analog input pin of A/D converter
E17	243	P29_7	I/O	B	General-purpose input/output port
		AN7			Analog input pin of A/D converter
D16	245	P27_6	I/O	B	General-purpose input/output port
		AN22			Analog input pin of A/D converter
		INT22			External interrupt pin

MB91460Q Series

JEDEC	Pin no.	Pin name	I/O	I/O circuit type ¹	Description
D14	247	P26_3	I/O	B	General-purpose input/output port
		AN27			Analog input pin of A/D converter
		INT27			External interrupt pin
D12	249	P26_7	I/O	B	General-purpose input/output port
		AN31			Analog input pin of A/D converter
		INT31			External interrupt pin
D10	251	P14_1	I/O	A	General-purpose input/output port
		ICU1			Input capture input pin
		TIN1			External trigger input pin of reload timer
		TTG9/1			External trigger input pin of PPG timer
D9	252	P14_5	I/O	A	General-purpose input/output port
		ICU5			Input capture input pin
		TIN5			External trigger input pin of reload timer
		TTG13/5			External trigger input pin of PPG timer
D7	254	P16_4	I/O	A	General-purpose input/output port
		PPG12			PPG timer output pin
		SGA			SGA output pin of sound generator
D5	256	P15_3	I/O	A	General-purpose input/output port
		OCU3			Output compare output pin
		TOT3			Reload timer output pin

1. For information about the I/O circuit type, refer to “■ I/O CIRCUIT TYPES”.
2. For usage of ICU8, PFR22[7] must be cleared and DDR22[7] should be cleared.
3. For usage of ICU9, PFR22[6] must be cleared and DDR22[6] should be cleared.

MB91460Q Series

[Power supply/Ground pins]

Pin no. (JEDEC)	Pin name	Description
1 (A1),20(Y1),34(Y15),39 (Y20), 58 (A20),205 (D4),209 (H4), 214 (N4),218 (U4),222 (U8), 227 (U13),231 (U17),235 (N17), 240 (H17),244 (D17),248 (D13), 253 (D8) 257 to 320 (G7..G14....P7..P14)	VSS	GND pins
233 (R17),237 (L17),242 (F17), 246 (D15),250 (D11),255 (D6)	VDD5	Power supply pins
207 (F4), 211 (K4),216 (R4), 220 (U6),224 (U10),229 (U15)	VDD35	Power supply pins for external bus
36 (Y17),37(Y18)	VDD5R	Power supply pin for internal regulator
60 (A18)	AVSS	Analog GND pin for A/D converter
63 (A15)	AVCC5	Power supply pin for A/D converter
62 (A16)	AVRH5	Reference power supply pin for A/D converter
38(Y19)	VCC18C	Capacitor connection pin for internal regulator

I/O CIRCUIT TYPES

Type	Circuit	Remarks
A	<p>pull-up control</p> <p>driver strength control</p> <p>data line</p> <p>pull-down control</p> <p>R</p> <p>CMOS hysteresis type1</p> <p>CMOS hysteresis type2</p> <p>Automotive inputs</p> <p>TTL input</p> <p>standby control for input shutdown</p>	<p>CMOS level output (programmable $I_{OL} = 5\text{mA}$, $I_{OH} = -5\text{mA}$ and $I_{OL} = 2\text{mA}$, $I_{OH} = -2\text{mA}$)</p> <p>2 different CMOS hysteresis inputs with input shutdown function</p> <p>Automotive input with input shutdown function</p> <p>TTL input with input shutdown function</p> <p>Programmable pull-up resistor: 50kΩ approx.</p>
B	<p>pull-up control</p> <p>driver strength control</p> <p>data line</p> <p>pull-down control</p> <p>R</p> <p>CMOS hysteresis type1</p> <p>CMOS hysteresis type2</p> <p>Automotive inputs</p> <p>TTL input</p> <p>standby control for input shutdown</p> <p>analog input</p>	<p>CMOS level output (programmable $I_{OL} = 5\text{mA}$, $I_{OH} = -5\text{mA}$ and $I_{OL} = 2\text{mA}$, $I_{OH} = -2\text{mA}$)</p> <p>2 different CMOS hysteresis inputs with input shutdown function</p> <p>Automotive input with input shutdown function</p> <p>TTL input with input shutdown function</p> <p>Programmable pull-up resistor: 50kΩ approx.</p> <p>Analog input</p>

MB91460Q Series

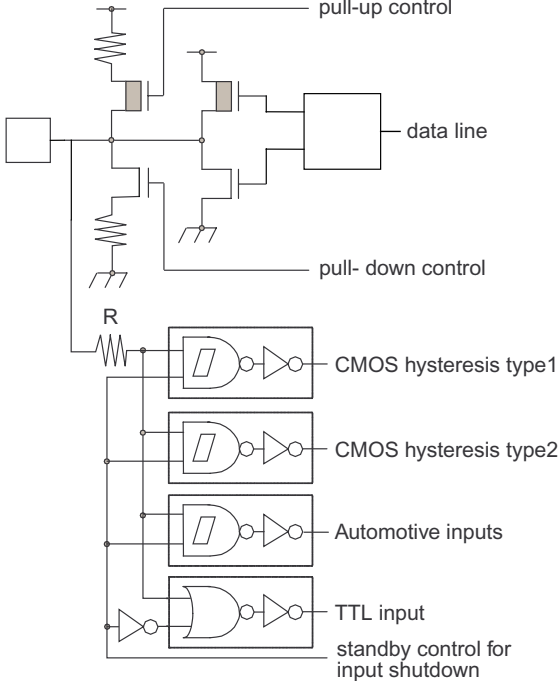
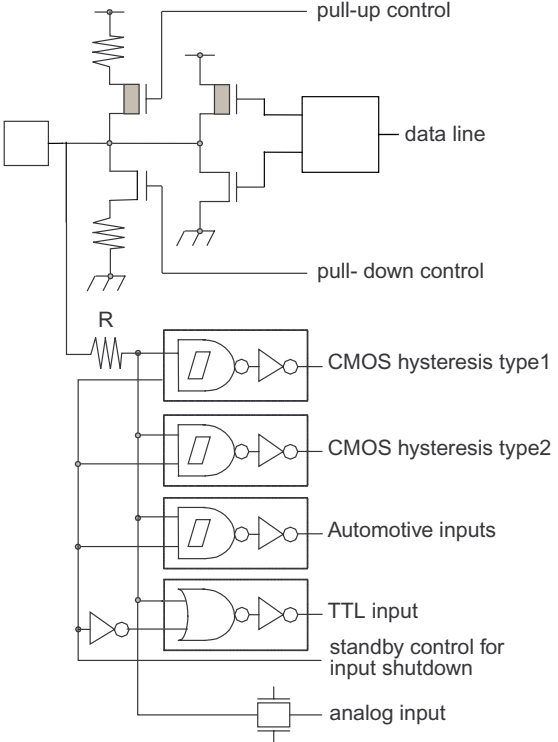
Type	Circuit	Remarks
C	 <p>pull-up control</p> <p>pull-down control</p> <p>data line</p> <p>R</p> <p>CMOS hysteresis type1</p> <p>CMOS hysteresis type2</p> <p>Automotive inputs</p> <p>TTL input</p> <p>standby control for input shutdown</p>	<p>CMOS level output ($I_{OL} = 3mA$, $I_{OH} = -3mA$)</p> <p>2 different CMOS hysteresis inputs with input shutdown function</p> <p>Automotive input with input shutdown function</p> <p>TTL input with input shutdown function</p> <p>Programmable pull-up resistor: 50kΩ approx.</p>
D	 <p>pull-up control</p> <p>pull-down control</p> <p>data line</p> <p>R</p> <p>CMOS hysteresis type1</p> <p>CMOS hysteresis type2</p> <p>Automotive inputs</p> <p>TTL input</p> <p>standby control for input shutdown</p> <p>analog input</p>	<p>CMOS level output ($I_{OL} = 3mA$, $I_{OH} = -3mA$)</p> <p>2 different CMOS hysteresis inputs with input shutdown function</p> <p>Automotive input with input shutdown function</p> <p>TTL input with input shutdown function</p> <p>Programmable pull-up resistor: 50kΩ approx.</p> <p>Analog input</p>

MB91460Q Series

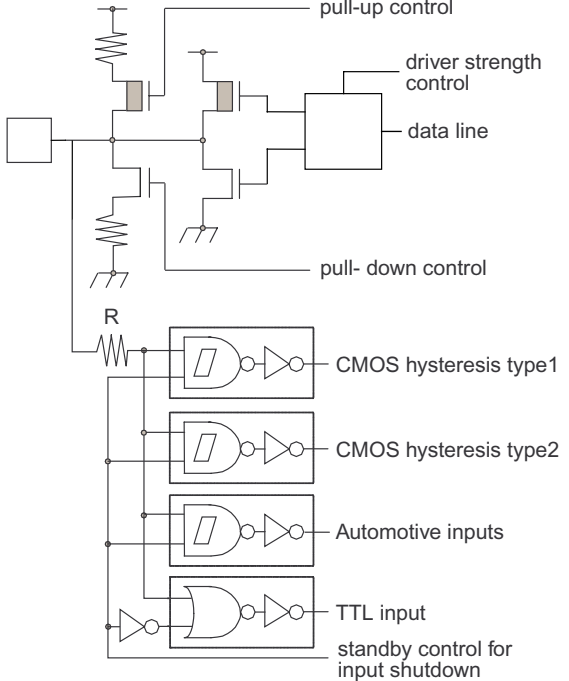
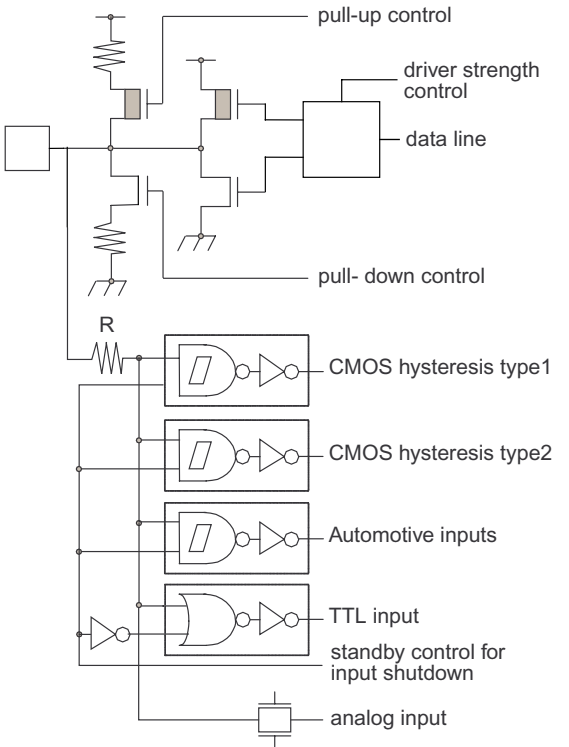
Type	Circuit	Remarks
E	 <p>pull-up control</p> <p>driver strength control</p> <p>data line</p> <p>pull-down control</p> <p>R</p> <p>CMOS hysteresis type1</p> <p>CMOS hysteresis type2</p> <p>Automotive inputs</p> <p>TTL input</p> <p>standby control for input shutdown</p>	<p>CMOS level output (programmable $I_{OL} = 5\text{mA}$, $I_{OH} = -5\text{mA}$ and $I_{OL} = 2\text{mA}$, $I_{OH} = -2\text{mA}$, and $I_{OL} = 30\text{mA}$, $I_{OH} = -30\text{mA}$)</p> <p>2 different CMOS hysteresis inputs with input shutdown function</p> <p>Automotive input with input shutdown function</p> <p>TTL input with input shutdown function</p> <p>Programmable pull-up resistor: 50kΩ approx.</p>
F	 <p>pull-up control</p> <p>driver strength control</p> <p>data line</p> <p>pull-down control</p> <p>R</p> <p>CMOS hysteresis type1</p> <p>CMOS hysteresis type2</p> <p>Automotive inputs</p> <p>TTL input</p> <p>standby control for input shutdown</p> <p>analog input</p>	<p>CMOS level output (programmable $I_{OL} = 5\text{mA}$, $I_{OH} = -5\text{mA}$ and $I_{OL} = 2\text{mA}$, $I_{OH} = -2\text{mA}$, and $I_{OL} = 30\text{mA}$, $I_{OH} = -30\text{mA}$)</p> <p>2 different CMOS hysteresis inputs with input shutdown function</p> <p>Automotive input with input shutdown function</p> <p>TTL input with input shutdown function</p> <p>Programmable pull-up resistor: 50kΩ approx.</p> <p>Analog input</p>

MB91460Q Series

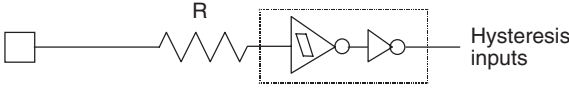
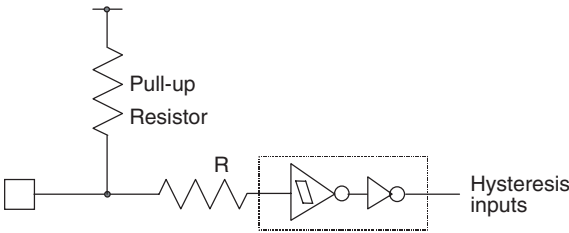
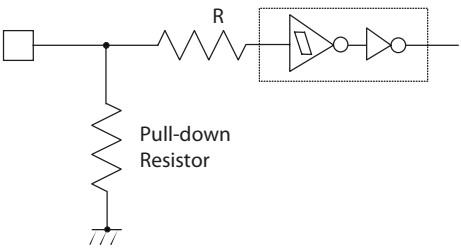
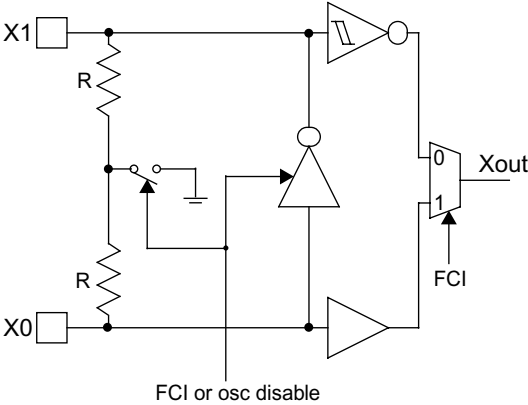
Type	Circuit	Remarks
G		Mask ROM and EVA device: CMOS Hysteresis input pin Flash device: CMOS input pin 12 V withstand (for MD [2:0])
H		CMOS Hysteresis input pin Pull-up resistor value: 50 kΩ approx.
I		CMOS Hysteresis input pin Pull-down resistor value: 50 kΩ approx.
J1		High-speed oscillation circuit: <ul style="list-style-type: none"> • Programmable between oscillation mode (external crystal or resonator connected to X0/X1 pins) and Fast external Clock Input (FCI) mode (external clock connected to X0 pin) • Feedback resistor = approx. $2 * 0.5 \text{ M}\Omega$. Feedback resistor is grounded in the center when the oscillator is disabled or in FCI mode.

MB91460Q Series

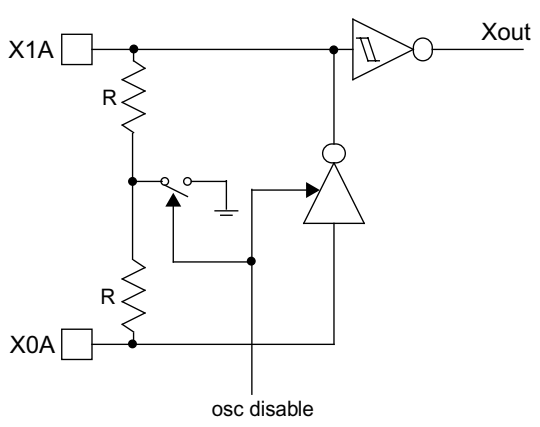
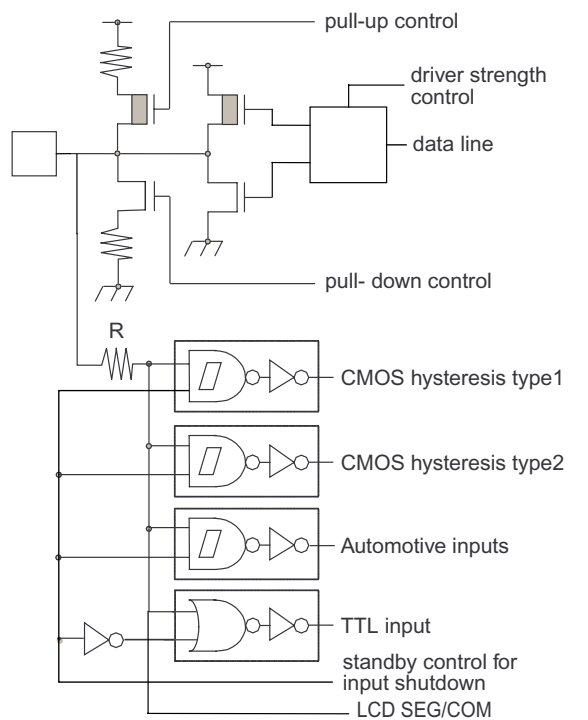
Type	Circuit	Remarks
J2		<p>Low-speed oscillation circuit:</p> <ul style="list-style-type: none"> Feedback resistor = approx. $2 \times 5 \text{ M}\Omega$. Feedback resistor is grounded in the center when the oscillator is disabled.
K		<p>CMOS level output (programmable $I_{OL} = 5\text{mA}$, $I_{OH} = -5\text{mA}$ and $I_{OL} = 2\text{mA}$, $I_{OH} = -2\text{mA}$)</p> <p>2 different CMOS hysteresis inputs with input shutdown function</p> <p>Automotive input with input shutdown function</p> <p>TTL input with input shutdown function</p> <p>Programmable pull-up resistor: $50\text{k}\Omega$ approx.</p> <p>LCD SEG/COM output</p>

MB91460Q Series

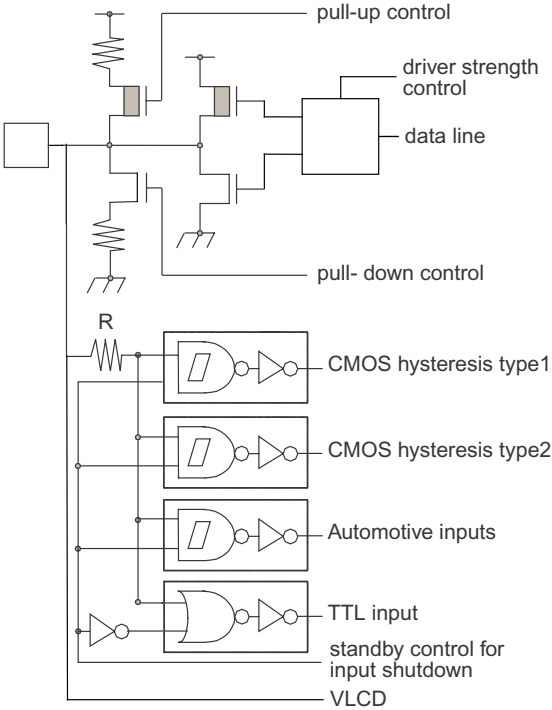
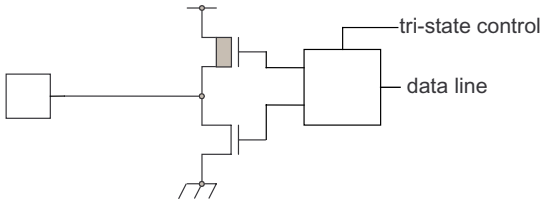
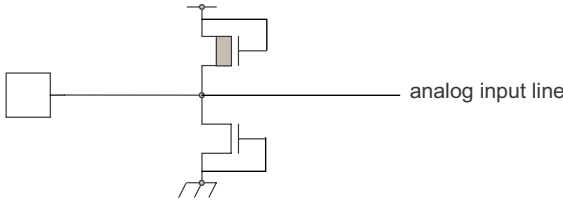
Type	Circuit	Remarks
L	 <p>pull-up control</p> <p>driver strength control</p> <p>data line</p> <p>pull-down control</p> <p>R</p> <p>CMOS hysteresis type1</p> <p>CMOS hysteresis type2</p> <p>Automotive inputs</p> <p>TTL input</p> <p>standby control for input shutdown</p> <p>VLCD</p>	<p>CMOS level output (programmable $I_{OL} = 5\text{mA}$, $I_{OH} = -5\text{mA}$ and $I_{OL} = 2\text{mA}$, $I_{OH} = -2\text{mA}$)</p> <p>2 different CMOS hysteresis inputs with input shutdown function</p> <p>Automotive input with input shutdown function</p> <p>TTL input with input shutdown function</p> <p>Programmable pull-up resistor: 50kΩ approx.</p> <p>Analog input</p> <p>LCD Voltage input</p>
M	 <p>tri-state control</p> <p>data line</p>	<p>CMOS level tri-state output ($I_{OL} = 5\text{mA}$, $I_{OH} = -5\text{mA}$)</p>
N	 <p>analog input line</p>	<p>Analog input pin with protection</p>

MB91460Q Series

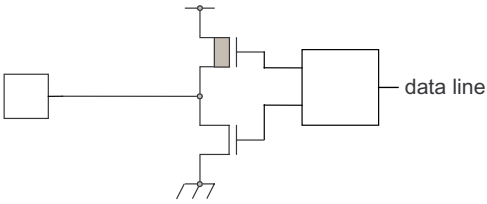
Type	Circuit	Remarks
O		CMOS level output ($I_{OL} = 5\text{mA}$, $I_{OH} = -5\text{mA}$)

MB91460Q Series

■ SPECIAL PORT / RESOURCE ASSIGNMENTS

In general, the port / resource assignments and the necessary register settings (PFR, EPFR) are described in the MB91460 series hardware manual. The assignments of MB91460Q series are different on some ports. This chapter explains the differences and the settings needed to enable the resources.

1. Overview Of Special Port / Resource Assignments

- MB91460Q series has a second A/D converter (ADC1), serving the channels AN34-39, AN42 and AN46. These analog channels are added to P17[7:2], P18[6] and P18[2].
- MB91460Q series has 16 more external interrupts (INT16-31), added to ports 27 and 26.
- The following external interrupts are re-located to other ports then described in the hardware manual: INT4, INT5, INT10, INT11, INT12, INT14.
- MB91460Q series has 2 more Input Capture Units (ICU8, ICU9) and one more Free Run Timer (FRT8).
- MB91460Q series has different initial function of the external bus IOs

2. The Second A/D converter (ADC1)

The second ADC is of the same macro type then ADC0 (10 bit, 1 μ s), and it has the same register set.

For the addresses, please refer to the IO MAP at address 0x5E0 to 0x5EB.

The external trigger signal (ATGX) for ADC1 comes from port P16[7] and is the same as for ADC0.

The internal trigger signal for ADC1 comes from Reload Timer 7 and is the same as for ADC0.

The analog input channels are assigned to the following bits of Ports 17 and 18:

Port 17								Func.	Enabled by
P17[7]	P17[6]	P17[5]	P17[4]	P17[3]	P17[2]	P17[1]	P17[0]	GPIO	PFR17=0
PPG7	PPG6	PPG5	PPG4	PPG3	PPG2	PPG1	PPG0	PPG	PFR17=1
AN39	AN38	AN37	AN36	AN35	AN34	-	-	ADC1	AD1ER [m-32]=1

Port 18								Func.	Enabled by
-	P18[6]	P18[5]	P18[4]	-	P18[2]	P18[1]	P18[0]	GPIO	PFR18=0
-	SCK7	SOT7	SIN7	-	SCK6	SOT6	SIN6	LIN	PFR18=1, EPFR18=0
	ZIN3, CK7	BIN3	AIN3	-	ZIN2, CK6	BIN2	AIN2	UDC, FRT	PFR18=1, EPFR18=1
-	AN46	-	-	-	AN42	-	-	ADC1	AD1ER [m-32]=1

m = 32 to 46 (ADC channel)

The analog channel IO is enabled independently of PFR/EPFR. It only depends on the appropriate **AD1ER**[n] bit (ADC channel enable). If an analog channel is enabled, the digital input stages are disabled by hardware. **Analog overwrites digital input.**

3. The Additional External Interrupts (INT16-31)

The additional external interrupts are controlled by a second external interrupt controller having similar register set. For the addresses, please refer to the IO MAP at address 0xC04 to 0xC0B.

The new interrupt functions are assigned to the ports 26 and 27:

Port 26								Func.	Enabled by
P26[7]	P26[6]	P26[5]	P26[4]	P26[3]	P26[2]	P26[1]	P26[0]	GPIO	PFR26=0
-	-	-	-	-	-	-	-	[SMC]	PFR26=1, EPFR26=0
AN31	AN30	AN29	AN28	AN27	AN26	AN25	AN24	ADC0	PFR26=1, EPFR26=1
INT31	INT30	INT29	INT28	INT27	INT26	INT25	INT24	INT	PFR27=1, EPFR27=1, ENIR3[m-24]=1 and ADERH[an-16]=0

Port 27								Func.	Enabled by
P27[7]	P27[6]	P27[5]	P27[4]	P27[3]	P27[2]	P27[1]	P27[0]	GPIO	PFR27=0
-	-	-	-	-	-	-	-	[SMC]	PFR27=1, EPFR27=0
AN23	AN22	AN21	AN20	AN19	AN18	AN17	AN16	ADC0	PFR27=1, EPFR27=1
INT23	INT22	INT21	INT20	INT19	INT218	INT17	INT16	INT	PFR27=1, EPFR27=1, ENIR2[m-16]=1 and ADERH[an-16]=0

m = 16 to 31 (INT channel)
an = 16 to 31 (ADC channel)

Note: MB91460Q series does not have Stepper Motor Controllers (SMC). On other devices of MB91460 series, the SMC lines are located on ports 25 to 27 and enabled by setting PFR=1, EPFR=0.

The new interrupts are assigned to ports having analog functions (SMC, ADC).

If an analog function is enabled on a pin, then all digital input functionality of this pin is disabled by hardware, and it is not possible to use the interrupt function. Analog overwrites digital input!

The ADC functions are enabled by setting PFR=1, EPFR=1 and ADREH=1 (ADERH is ADC channel enable register of ADC0). If the ADC functions are enabled, the digital input lines are disabled. CMOS-Schmitt, Automotive and CMOS-2 level input lines keep their value (bus holder behaviour) while the TTL input line is tied to low level. In this state, external interrupts cannot be used.

If the analog functions are disabled (ADREH=0), the interrupt can be used after setting the appropriate interrupt channel enable bit in ENIR2/EINR3 register as well as PFR and EPFR. Setting these registers enables the digital input stages for wakeup in STOP mode.

4. Re-located External Interrupts (INT4, INT5, INT10, INT11, INT12, INT14)

The re-located interrupts are assigned to ports different to other devices of MB91460 series:

Port 24	Port 35		Port 34			Func.	Enabled by
P24[4]	P35[4]	P35[0]	P34[5]	P34[4]	P34[0]	GPIO	PFR=0
SDA2	-	-	-	-	-	[LCD]	PFR=1, EPFR=0
-	SIN9	SIN8	SOT11	SIN11	SIN10	I2C/ LIN	PFR=1, EPFR=1
INT14	INT12	INT11	INT5	INT4	INT10	ADC1	ENIR1/0[m]=1

MB91460Q Series

Notes: MB91460Q series does not have the LCD Controller.

On other devices of MB91460 series, the LCD lines are located on ports 30 to 36 and enabled by setting PFR=1, EPFR=0. This setting would disable the digital input lines on other devices. To keep the software compatible to the new evaluation device, avoid setting PFR=1 & EPFR=0.

Note: Take care about INT5 because it is attached to SOT11 (LIN-USART output direction if PFR=EPFR=1!)

If the LCD function is disabled, the interrupt can be used after setting the appropriate interrupt channel enable bit in ENIR0/ENIR1 register. Setting ENIR0/ENIR1 enables the digital input stages for wakeup in STOP mode. But setting ENIR does **not** switch the port direction to input mode. The user should take care that the port is operating in input direction before expecting external interrupts.

5. Input Capture Units (ICU8,9) and Free Run Timer (FRT8)

MB91460Q series has 2 more ICUs and one more FRT. The assignments are the following:

Port 22		Port 21	Func.	Enabled by	Comments
P22[7]	P22[6]	P21[2]	GPIO	PFR=0	
SCL1	SDA1	SCK0	I2C / LIN	PFR=1	Port 22 does not have EPFR.
-	INT15	-	INT	PFR=1	Port 22 does not have EPFR.
-	-	CK0/8	FRT	PFR=1, EPFR=1	PFR=1 & EPFR=1 just switches the port 21[2] to input direction. FRT8 uses the same input signal as FRT0.
ICU9	ICU8	-	ICU	PFR=1 or PFR=0	PFR switches the ICU input signal between LIN-USART.LSYNC and the pin.

PFR22[7:6] switch the input signals of the ICU modules 9 and 8:

PFR	Value	ICU input connection
PFR22[7]	0	ICU9 input is connected to port 22[7] input line (default)
	1	ICU9 input is connected to the LSYNC output of LIN-USART9
PFR22[6]	0	ICU8 input is connected to port 22[6] input line (default)
	1	ICU8 input is connected to the LSYNC output of LIN-USART8

Note: For ICU0-7, this multiplexing is controlled by EPFR14 register.

6. External Bus Function After Reset

Older devices of MB91460 series switch on the external bus after reset by setting the PFR registers of the ports 00 to 10. This behaviour appears in external vector fetch mode (MD[2:0]=001) as well as in internal vector fetch mode (MD[2:0]=000).

New devices of MB91460 series (including MB91460Q) do **not** switch on the external bus in internal vector fetch mode (MD[2:0]=000).

■ HANDLING DEVICES

1. Preventing Latch-up

Latch-up may occur in a CMOS IC if a voltage higher than (V_{DD5} , V_{DD35}) or less than (V_{SS5}) is applied to an input or output pin or if a voltage exceeding the rating is applied between the power supply pins and ground pins. If latch-up occurs, the power supply current increases rapidly, sometimes resulting in thermal breakdown of the device. Therefore, be very careful not to apply voltages in excess of the absolute maximum ratings.

2. Handling of unused input pins

If unused input pins are left open, abnormal operation may result. Any unused input pins should be connected to pull-up or pull-down resistor ($2K\Omega$ to $10K\Omega$) or enable internal pullup or pulldown resistors (PPER/PPCR) before the input enable (PORTEN) is activated by software. The mode pins MD_x can be connected to V_{SS5} or V_{DD5} directly. Unused ALARM input pins can be connected to AV_{SS5} directly.

3. Power supply pins

In MB91460Q series, devices including multiple power supply pins and ground pins are designed as follows; pins necessary to be at the same potential are interconnected internally to prevent malfunctions such as latch-up. All of the power supply pins and ground pins must be externally connected to the power supply and ground respectively in order to reduce unnecessary radiation, to prevent strobe signal malfunctions due to the ground level rising and to follow the total output current ratings. Furthermore, the power supply pins and ground pins of the MB91460Q series must be connected to the current supply source via a low impedance.

It is also recommended to connect a ceramic capacitor of approximately $0.1\ \mu\text{F}$ as a bypass capacitor between power supply pin and ground pin near this device.

This series has a built-in step-down regulator. Connect a bypass capacitor of $4.7\ \mu\text{F}$ (use a X7R ceramic capacitor) to VCC18C pin for the regulator.

4. Crystal oscillator circuit

Noise in proximity to the X0 (X0A) and X1 (X1A) pins can cause the device to operate abnormally. Printed circuit boards should be designed so that the X0 (X0A) and X1 (X1A) pins, and crystal oscillator, as well as bypass capacitors connected to ground, are located near the device and ground.

It is recommended that the printed circuit board layout be designed such that the X0 and X1 pins or X0A and X1A pins are surrounded by ground plane for the stable operation.

Please request the oscillator manufacturer to evaluate the oscillational characteristics of the crystal and this device.

5. Notes on using external clock

When using the external clock, it is necessary to simultaneously supply the X0 (X0A) and the X1 (X1A) pins. In the described combination, X1 (X1A) should be supplied with a clock signal which has the opposite phase to the X0 (X0A) pins. At X0 and X1, a frequency up to 16 MHz is possible.

(Continued)

MB91460Q Series

(Continued)

Example of using opposite phase supply

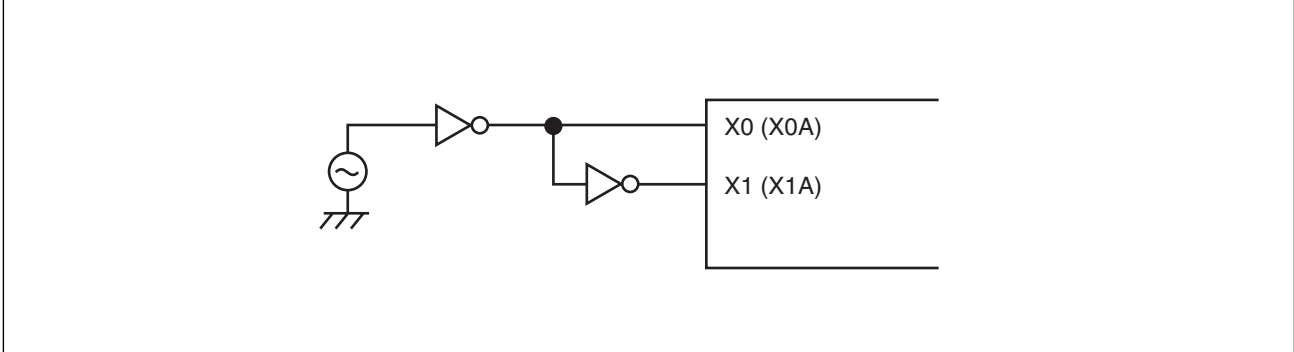

6. Mode pins (MD_x)

These pins should be connected directly to the power supply or ground pins. To prevent the device from entering test mode accidentally due to noise, minimize the lengths of the patterns between each mode pin and power supply pin or ground pin on the printed circuit board as possible and connect them with low impedance.

7. Notes on operating in PLL clock mode

If the oscillator is disconnected or the clock input stops when the PLL clock is selected, the microcontroller may continue to operate at the free-running frequency of the self-oscillating circuit of the PLL. However, this self-running operation cannot be guaranteed.

8. Pull-up control

The AC standard is not guaranteed in case a pull-up resistor is connected to the pin serving as an external bus pin.

9. Notes on PS register

As the PS register is processed in advance by some instructions, when the debugger is being used, the exception handling may result in execution breaking in an interrupt handling routine or the displayed values of the flags in the PS register being updated.

As the microcontroller is designed to carry out reprocessing correctly upon returning from such an EIT event, the operation before and after the EIT always proceeds according to specification.

- **The following behavior may occur if any of the following occurs in the instruction immediately after a DIV0U/DIV0S instruction:**

- (a) a user interrupt or NMI is accepted;
- (b) single-step execution is performed;
- (c) execution breaks due to a data event or from the emulator menu.
 1. D0 and D1 flags are updated in advance.
 2. An EIT handling routine (user interrupt/NMI or emulator) is executed.
 3. Upon returning from the EIT, the DIV0U/DIV0S instruction is executed and the D0 and D1 flags are updated to the same values as those in 1.

- **The following behavior occurs when an ORCCR, STILM, MOV Ri,PS instruction is executed to enable a user interrupt or NMI source while that interrupt is in the active state.**

1. The PS register is updated in advance.
2. An EIT handling routine (user interrupt/NMI or emulator) is executed.
3. Upon returning from the EIT, the above instructions are executed and the PS register is updated to the same value as in 1.

■ NOTES ON DEBUGGER

1. Execution of the RETI Command

If single-step execution is used in an environment where an interrupt occurs frequently, the corresponding interrupt handling routine will be executed repeatedly to the exclusion of other processing. This will prevent the main routine and the handlers for low priority level interrupts from being executed (For example, if the time-base timer interrupt is enabled, stepping over the RETI instruction will always break on the first line of the time-base timer interrupt handler).

Disable the corresponding interrupts when the corresponding interrupt handling routine no longer needs debugging.

2. Break function

If the range of addresses that cause a hardware break (including event breaks) is set to the address of the current system stack pointer or to an area that contains the stack pointer, execution will break after each instruction regardless of whether the user program actually contains data access instructions.

To prevent this, do not set (word) access to the area containing the address of the system stack pointer as the target of the hardware break (including an event breaks).

3. Operand break

It may cause malfunctions if a stack pointer exists in the area which is set as the DSU operand break. Do not set the access to the areas containing the address of system stack pointer as a target of data event break.

■ BLOCK DIAGRAM

1. MB91F469QA

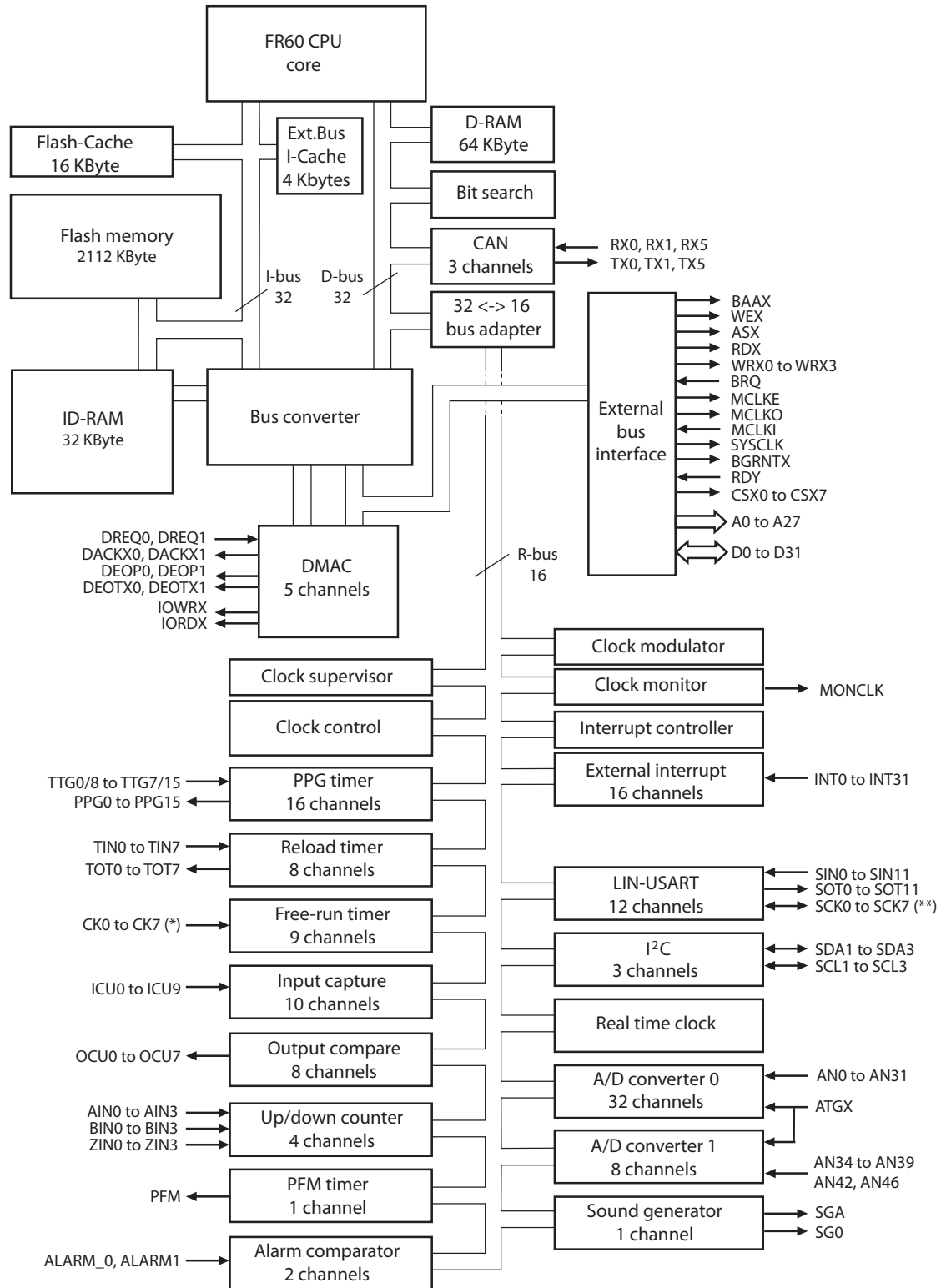

Notes: (*) Free-run timer 8 without external clock pin
 (**) LIN-USART 8 to 11 asynchronous only (without SCK pin)

MB91460Q Series

■ CPU AND CONTROL UNIT

The FR family CPU is a high performance core that is designed based on the RISC architecture with advanced instructions for embedded applications.

1. Features

- Adoption of RISC architecture
Basic instruction: 1 instruction per cycle
- General-purpose registers: 32-bit 16 registers
- 4 Gbytes linear memory space
- Multiplier installed
32-bit 32-bit multiplication: 5 cycles
16-bit 16-bit multiplication: 3 cycles
- Enhanced interrupt processing function
Quick response speed (6 cycles)
Multiple-interrupt support
Level mask function (16 levels)
- Enhanced instructions for I/O operation
Memory-to-memory transfer instruction
Bit processing instruction
Basic instruction word length: 16 bits
- Low-power consumption
Sleep mode/stop mode

2. Internal architecture

- The FR family CPU uses the Harvard architecture in which the instruction bus and data bus are independent of each other.
- A 32-bit ↔ 16-bit buffer is connected to the 32-bit bus (D-bus) to provide an interface between the CPU and peripheral resources.
- A Harvard ↔ Princeton bus converter is connected to both the I-bus and D-bus to provide an interface between the CPU and the bus controller.

3. Programming model

3.1. Basic programming model

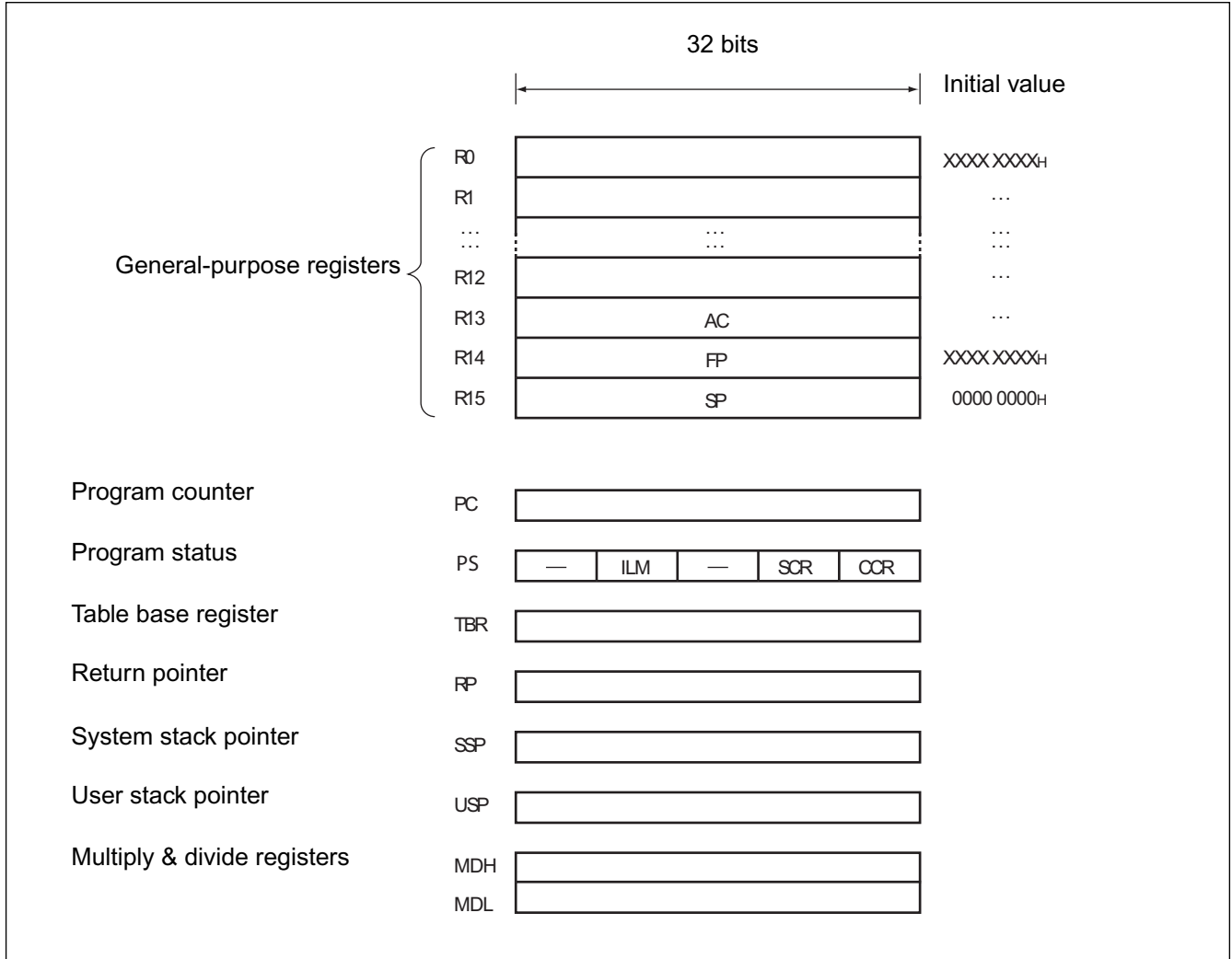

MB91460Q Series

4. Registers

4.1. General-purpose register

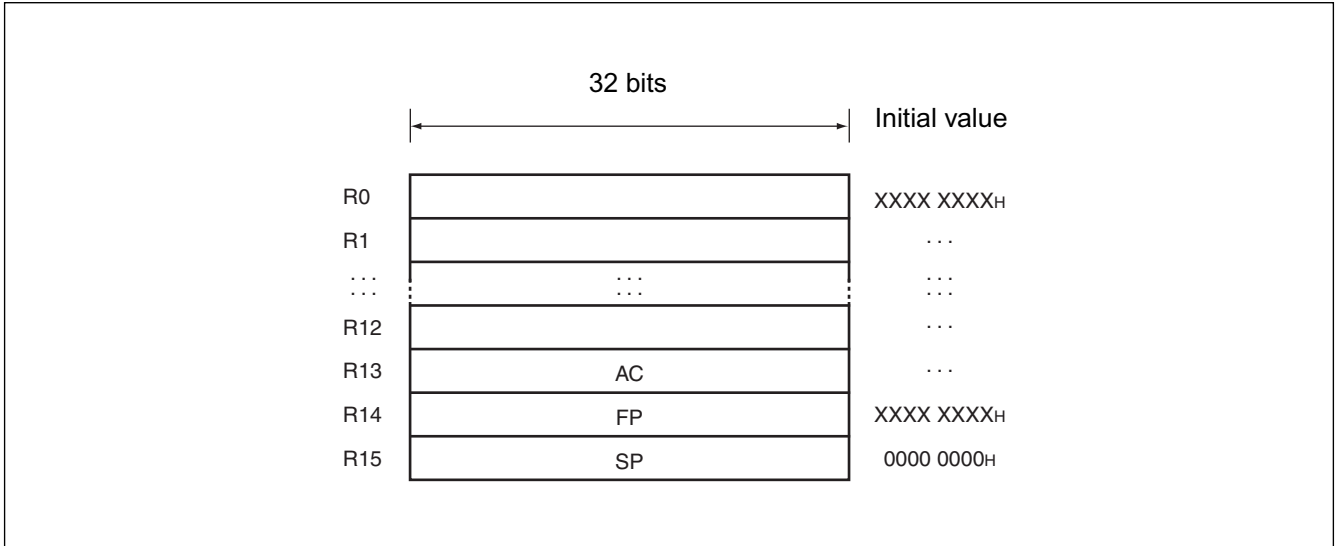

Registers R0 to R15 are general-purpose registers. These registers can be used as accumulators for computation operations and as pointers for memory access.

Of the 16 registers, enhanced commands are provided for the following registers to enable their use for particular applications.

R13 : Virtual accumulator

R14 : Frame pointer

R15 : Stack pointer

Initial values at reset are undefined for R0 to R14. The value for R15 is 00000000_H (SSP value).

4.2. PS (Program Status)

This register holds the program status, and is divided into three parts, ILM, SCR, and CCR.

All undefined bits (-) in the diagram are reserved bits. The read values are always "0". Write access to these bits is invalid.

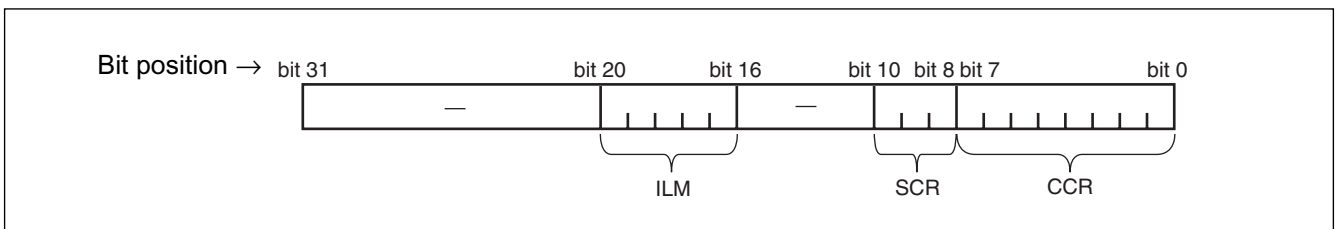

4.3. CCR (Condition Code Register)

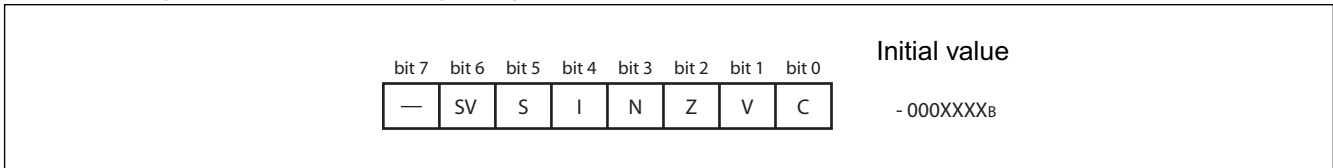

- SV : Supervisor flag
- S : Stack flag
- I : Interrupt enable flag
- N : Negative enable flag
- Z : Zero flag
- V : Overflow flag
- C : Carry flag

4.4. SCR (System Condition Register)

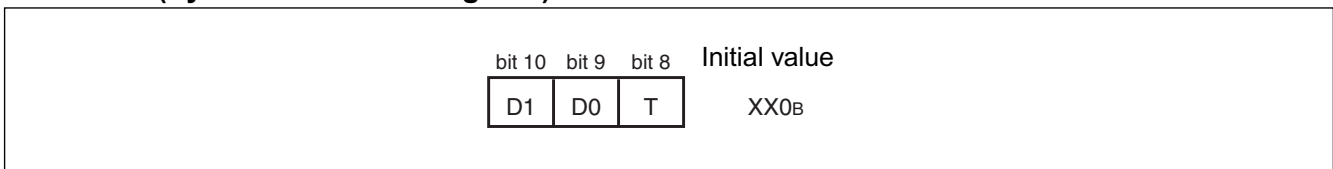

Flag for step division (D1, D0)
This flag stores interim data during execution of step division.

Step trace trap flag (T)
This flag indicates whether the step trace trap is enabled or disabled.
The step trace trap function is used by emulators. When an emulator is in use, it cannot be used in execution of user programs.

4.5. ILM (Interrupt Level Mask register)

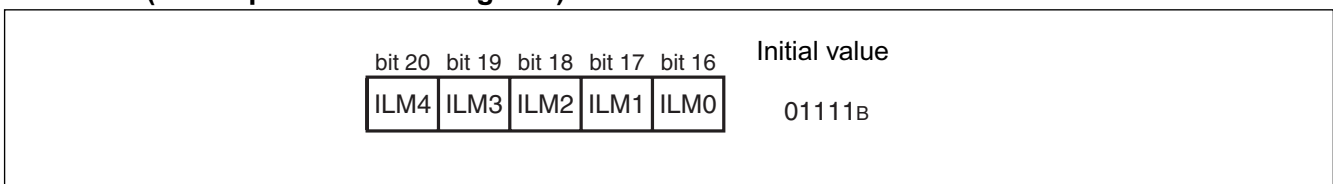

This register stores interrupt level mask values, and the values stored in ILM4 to ILM0 are used for level masking.
The register is initialized to value “01111_B” at reset.

4.6. PC (Program Counter)

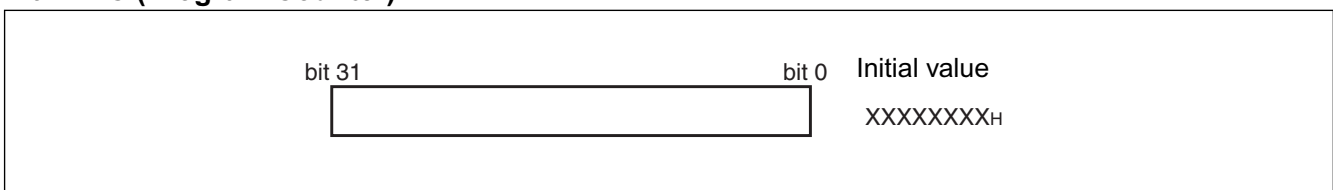

The program counter indicates the address of the instruction that is being executed.
The initial value at reset is undefined.

MB91460Q Series

4.7. TBR (Table Base Register)

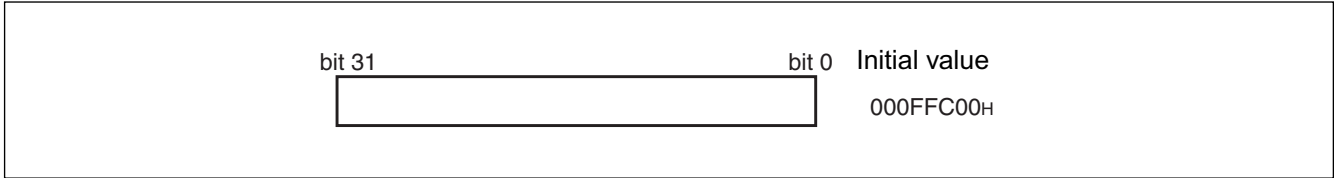

The table base register stores the starting address of the vector table used in EIT processing.
The initial value at reset is 000FFC00H.

4.8. RP (Return Pointer)

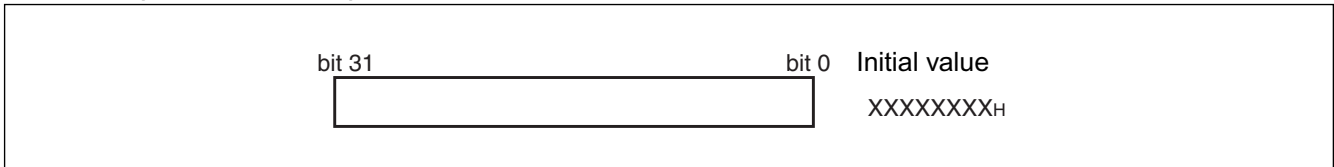

The return pointer stores the address for return from subroutines.
During execution of a CALL instruction, the PC value is transferred to this RP register.
During execution of a RET instruction, the contents of the RP register are transferred to PC.
The initial value at reset is undefined.

4.9. USP (User Stack Pointer)

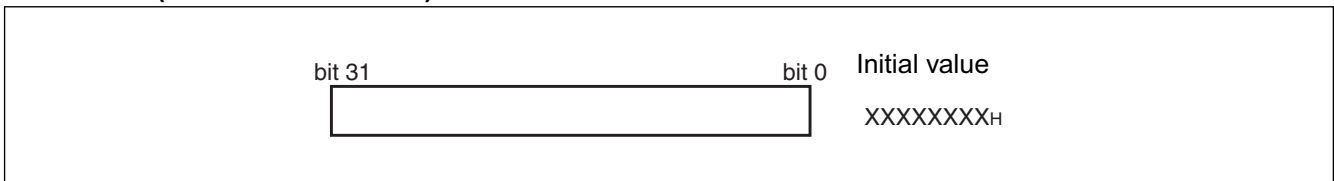

The user stack pointer, when the S flag is "1", this register functions as the R15 register.

- The USP register can also be explicitly specified.
The initial value at reset is undefined.
- This register cannot be used with RETI instructions.

4.10. Multiply & divide registers

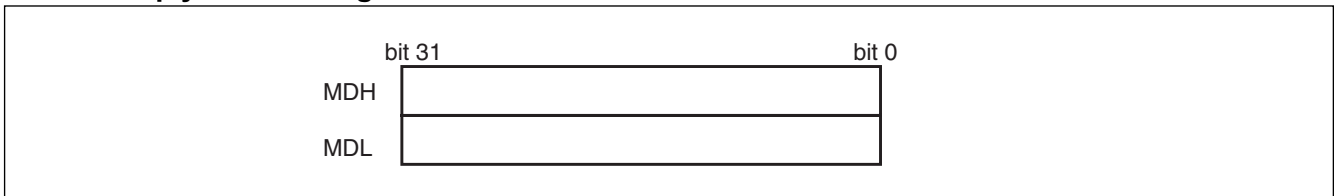

These registers are for multiplication and division, and are each 32 bits in length.
The initial value at reset is undefined.

■ EMBEDDED PROGRAM/DATA MEMORY (FLASH)

1. Flash features

- MB91F469QA: 2112 Kbytes (32×64 Kbytes + 8×8 Kbytes = 16.5 Mbits)
- Programmable wait state for read/write access
- Flash and Boot security with security vector at 0x0024:8000 - 0x0024:800F
- Boot security
- Basic specification: Same as MBM29LV400TC (except size and part of sector configuration)

2. Operation modes

(1) 64-bit CPU mode:

- CPU reads and executes programs in word (32-bit) length units.
- Flash writing is not possible.
- Actual Flash Memory access is performed in d-word (64-bit) length units.

(2) 32-bit CPU mode :

- CPU reads and executes programs in word (32-bit) length units.
- Actual Flash Memory access is performed in word (32-bit) length units.

(3) 16-bit CPU mode :

- CPU reads and writes in half-word (16-bit) length units.
- Program execution from the Flash is not possible.
- Actual Flash Memory access is performed in half-word (16-bit) length units.

Note: The operation mode of the flash memory can be selected using a Boot-ROM function. The function start address is 0xBF60. The parameter description is given in the Hardware Manual in chapter 54.6 "Flash Access Mode Switching".

MB91460Q Series

3. Flash access in CPU mode

3.1. Flash configuration

3.1.1. Flash memory map MB91F469QA

Address									
0024:FFFFh 0024:C000h	SA6 (8KB)				SA7 (8KB)				ROMS10
0024:BFFFh 0024:8000h	SA4 (8KB)				SA5 (8KB)				
0024:7FFFh 0024:4000h	SA2 (8KB)				SA3 (8KB)				
0024:3FFFh 0024:0000h	SA0 (8KB)				SA1 (8KB)				
0023:FFFFh 0022:0000h	SA38 (64KB)				SA39 (64KB)				ROMS9
0021:FFFFh 0020:0000h	SA36 (64KB)				SA37 (64KB)				
001F:FFFFh 001E:0000h	SA34 (64KB)				SA35 (64KB)				ROMS8
001D:FFFFh 001C:0000h	SA32 (64KB)				SA33 (64KB)				
001B:FFFFh 001A:0000h	SA30 (64KB)				SA31 (64KB)				ROMS7
0019:FFFFh 0018:0000h	SA28 (64KB)				SA29 (64KB)				
0017:FFFFh 0016:0000h	SA26 (64KB)				SA27 (64KB)				ROMS6
0015:FFFFh 0014:0000h	SA24 (64KB)				SA25 (64KB)				
0013:FFFFh 0012:0000h	SA22 (64KB)				SA23 (64KB)				ROMS5
0011:FFFFh 0010:0000h	SA20 (64KB)				SA21 (64KB)				
000F:FFFFh 000E:0000h	SA18 (64KB)				SA19 (64KB)				ROMS4
000D:FFFFh 000C:0000h	SA16 (64KB)				SA17 (64KB)				
000B:FFFFh 000A:0000h	SA14 (64KB)				SA15 (64KB)				ROMS3
0009:FFFFh 0008:0000h	SA12 (64KB)				SA13 (64KB)				
0007:FFFFh 0006:0000h	SA10 (64KB)				SA11 (64KB)				ROMS2
0005:FFFFh 0004:0000h	SA8 (64KB)				SA9 (64KB)				
	addr+0	addr+1	addr+2	addr+3	addr+4	addr+5	addr+6	addr+7	
16bit write mode	dat[31:16]		dat[15:0]		dat[31:16]		dat[15:0]		
32bit write mode	dat[31:0]				dat[31:0]				

3.2. Flash access timing settings in CPU mode

The following tables list all settings for a given maximum Core Frequency (through the setting of CLKB or maximum clock modulation) and voltage supplies for Flash read and write access..

3.2.1. Flash read timing settings (synchronous read)

Core clock (CLKB)	ATD	ALEH	EQ	WEXH	WTC	Flash/Main supply voltage
to 24 MHz	0	0	0	-	1	1.9V *1
to 48 MHz	0	0	1	-	2	1.9V *1
to 100 MHz	1	1	3	-	4	1.9V *1

3.2.2. Flash write timing settings (synchronous write)

Core clock (CLKB)	ATD	ALEH	EQ	WEXH	WTC	Flash/Main supply voltage
to 16 MHz	0	-	-	0	3	1.9V *1
to 32 MHz	0	-	-	0	4	1.9V *1
to 48 MHz	0	-	-	0	5	1.9V *1
to 64 MHz	1	-	-	0	6	1.9V *1
to 96 MHz	1	-	-	0	7	1.9V *1
to 100 MHz	1	-	-	1	8	1.9V *1

*1: In order to enter this mode please set REGSEL_FLASHSEL=1 and REGSEL_MAINSEL=1.

MB91460Q Series

3.3. Address mapping from CPU to parallel programming mode

The following tables show the calculation from CPU addresses to flash macro addresses which are used in parallel programming.

:

3.3.1. Address mapping MB91F469QA

CPU Address (addr)	Condition	Flash sectors	FA (flash address) Calculation
24:0000h to 24:FFFFh	addr[2]==0	SA0, SA2, SA4, SA6 (8 Kbyte)	$FA := addr - addr\%00:4000h + (addr\%00:4000h)/2 - (addr/2)\%4 + addr\%4 - 05:0000h$
24:0000h to 24:FFFFh	addr[2]==1	SA1, SA3, SA5, SA7 (8 Kbyte)	$FA := addr - addr\%00:4000h + (addr\%00:4000h)/2 - (addr/2)\%4 + addr\%4 - 05:0000h + 00:2000h$
04:0000h to 23:FFFFh	addr[2]==0	SA8, SA10, SA12, SA14, SA16, SA18, SA20, SA22, SA24, SA26, SA28, SA30, SA32, SA34, SA36, SA38 (64 Kbyte)	$FA := addr - addr\%02:0000 + (addr\%02:0000h)/2 - (addr/2)\%4 + addr\%4 + 1C:0000h$
04:0000h to 23:FFFFh	addr[2]==1	SA9, SA11, SA13, SA15, SA17, SA19, SA21, SA23, SA25, SA27, SA29, SA31, SA33, SA35, SA37, SA39 (64 Kbyte)	$FA := addr - addr\%02:0000h + (addr\%02:0000h)/2 - (addr/2)\%4 + addr\%4 + 1C:0000h + 01:0000h$

Note: FA result is without 40:0000h offset for parallel Flash programming .

Set offset by keeping FA[22] = 1 as described in section "Parallel Flash programming mode".

MB91460Q Series

4.2. Pin connections in parallel programming mode

Resetting after setting the MD[2:0] pins to [111] will halt CPU functioning. At this time, the Flash memory's interface circuit enables direct control of the Flash memory unit from external pins by directly linking some of the signals to General Purpose Ports. Please see table below for signal mapping.

In this mode, the Flash memory appears to the external pins as a stand-alone unit. This mode is generally set when writing/erasing using the parallel Flash programmer. In this mode, all operations of the 16.5 Mbits Flash memory's Auto Algorithms are available.

Correspondence between MBM29LV400TC and Flash Memory Control Signals

MBM29LV400TC External pins	FR-CPU mode	MB91F469QA external pins			Comment
		Flash memory mode	Normal function	Pin number	
—	INITX	—	INITX	U16 (230)	
RESET	—	FRSTX	P00_6	Y12 (31)	
—	—	MD_2	MD_2	V15 (172)	Set to '1'
—	—	MD_1	MD_1	V16 (173)	Set to '1'
—	—	MD_0	MD_0	V17 (174)	Set to '1'
RY/BY	FMCS:RDY bit	RY/BYX	P00_0	W10 (102)	
BYTE	Internally fixed to 'H'	BYTEX	P00_2	U11 (225)	
WE	Internal control signal + control via interface circuit	WEX	P01_2	Y8 (27)	
OE		OEX	P01_1	W8 (100)	
CE		CEX	P01_0	V8 (165)	
—		ATDIN	P01_4	V9 (166)	Set to '0'
—		EQIN	P01_3	U9 (233)	Set to '0'
—		TESTX	P00_3	V11 (168)	Set to '1'
—		RDYI	P00_1	Y10 (29)	Set to '0'
A-1		FA0	P14_6	A8 (70)	Set to '0'
A0 to A7	Internal address bus	FA1 to FA8	P16_0 to P16_7	0: C8 (200) 1: A7(71), 2: B7(140), 3: C7(201), 4: D7(254), 5: A6(72), 6: B6(141), 7: C6(202)	

(Continued)

MB91460Q Series

(Continued)

MBM29LV400TC External pins	FR-CPU mode	MB91F469QA external pins			Comment
		Flash memory mode	Normal function	Pin number	
A8 to A15	Internal address bus	FA9 to FA16	P15_0 to P15_7	0: A5(73), 1: B5(142), 2: C5(203), 3: D5(256), 4: A4(74), 5: B4(143), 6: C4(204), 7: A3(75)	
A16 to A20		FA17 to FA21	P14_0 to P14_4	0: C10(198), 1: D10(251), 2: A9(69), 3: B9(138), 4: C9(199)	
—		FA22	GP14_5	D9 (252)	Set to '1'
DQ0 to DQ7	Internal data bus	DQ0 to DQ7	P03_0 to P03_7	0: W3(95), 1: Y3(22), 2: V4(161), 3: W4(96), 4: Y4(23), 5: U5(219), 6: V5(162), 7: W5(97)	
DQ8 to DQ15		DQ8 to DQ15	P02_0 to P02_7	0: Y5(24), 1: V6(163), 2: W6(98), 3: Y6(25), 4: U7(221), 5: V7(164), 6: W7(99), 7: Y7(26)	

MB91460Q Series

5. Poweron Sequence in parallel programming mode

The flash memory can be accessed in programming mode after a certain wait time, which is needed for Security Vector fetch:

- Minimum wait time after VDD5/VDD5R power on: 2.76 ms
- Minimum wait time after INITX rising: 1.0 ms

6. Flash Security

6.1. Vector addresses

Two Flash Security Vectors (FSV1, FSV2) are located parallel to the Boot Security Vectors (BSV1, BSV2) controlling the protection functions of the Flash Security Module:

FSV1: 0x24:8000 BSV1: 0x24:8004
FSV2: 0x24:8008 BSV2: 0x24:800C

6.2. Security Vector FSV1

The setting of the Flash Security Vector FSV1 is responsible for the read and write protection modes and the individual write protection of the 8 Kbytes sectors.

6.2.1. FSV1 (bit31 to bit16)

The setting of the Flash Security Vector FSV1 bits [31:16] is responsible for the read and write protection modes.

Explanation of the bits in the Flash Security Vector FSV1 [31:16]

FSV1[31:19]	FSV1[18] Write Protection Level	FSV1[17] Write Protection	FSV1[16] Read Protection	Flash Security Mode
set all to "0"	set to "0"	set to "0"	set to "1"	Read Protection (all device modes, except INTVEC mode MD[2:0] = "000")
set all to "0"	set to "0"	set to "1"	set to "0"	Write Protection (all device modes, without exception)
set all to "0"	set to "0"	set to "1"	set to "1"	Read Protection (all device modes, except INTVEC mode MD[2:0] = "000") and Write Protection (all device modes)
set all to "0"	set to "1"	set to "0"	set to "1"	Read Protection (all device modes, except INTVEC mode MD[2:0] = "000")
set all to "0"	set to "1"	set to "1"	set to "0"	Write Protection (all device modes, except INTVEC mode MD[2:0] = "000")
set all to "0"	set to "1"	set to "1"	set to "1"	Read Protection (all device modes, except INTVEC mode MD[2:0] = "000") and Write Protection (all device modes except INTVEC mode MD[2:0] = "000")

6.2.2. FSV1 (bit15 to bit0)

The setting of the Flash Security Vector FSV1 bits [15:0] is responsible for the individual write protection of the 8 Kbytes sectors. It is only evaluated if write protection bit FSV1[17] is set.

Explanation of the bits in the Flash Security Vector FSV1 [15:0]

FSV1 bit	Sector	Enable Write Protection	Disable Write Protection	Comment
FSV1[0]	SA0	set to "0"	set to "1"	
FSV1[1]	SA1	set to "0"	set to "1"	
FSV1[2]	SA2	set to "0"	set to "1"	
FSV1[3]	SA3	set to "0"	set to "1"	
FSV1[4]	SA4	set to "0"	—	write protection is mandatory!
FSV1[5]	SA5	set to "0"	set to "1"	
FSV1[6]	SA6	set to "0"	set to "1"	
FSV1[7]	SA7	set to "0"	set to "1"	
FSV1[8]	—	set to "0"	set to "1"	not available
FSV1[9]	—	set to "0"	set to "1"	not available
FSV1[10]	—	set to "0"	set to "1"	not available
FSV1[11]	—	set to "0"	set to "1"	not available
FSV1[12]	—	set to "0"	set to "1"	not available
FSV1[13]	—	set to "0"	set to "1"	not available
FSV1[14]	—	set to "0"	set to "1"	not available
FSV1[15]	—	set to "0"	set to "1"	not available

Note : It is mandatory to always set the sector where the Flash Security Vectors FSV1 and FSV2 are located to write protected (here sector SA4). Otherwise it is possible to overwrite the Security Vector to a setting where it is possible to either read out the Flash content or manipulate data by writing.

See section "Flash access in CPU mode" for an overview about the sector organisation of the Flash Memory.

MB91460Q Series

6.3. Security Vector FSV2

The setting of the Flash Security Vector FSV2 bits [31:0] is responsible for the individual write protection of the 64 Kbytes sectors. It is only evaluated if write protection bit FSV1 [17] is set.

Explanation of the bits in the Flash Security Vector FSV2[31:0]

FSV2 bit	Sector	Enable Write Protection	Disable Write Protection	Comment
FSV2[0]	SA8	set to "0"	set to "1"	
FSV2[1]	SA9	set to "0"	set to "1"	
FSV2[2]	SA10	set to "0"	set to "1"	
FSV2[3]	SA11	set to "0"	set to "1"	
FSV2[4]	SA12	set to "0"	set to "1"	
FSV2[5]	SA13	set to "0"	set to "1"	
FSV2[6]	SA14	set to "0"	set to "1"	
FSV2[7]	SA15	set to "0"	set to "1"	
FSV2[8]	SA16	set to "0"	set to "1"	
FSV2[9]	SA17	set to "0"	set to "1"	
FSV2[10]	SA18	set to "0"	set to "1"	
FSV2[11]	SA19	set to "0"	set to "1"	
FSV2[12]	SA20	set to "0"	set to "1"	
FSV2[13]	SA21	set to "0"	set to "1"	
FSV2[14]	SA22	set to "0"	set to "1"	
FSV2[15]	SA23	set to "0"	set to "1"	
FSV2[16]	SA24	set to "0"	set to "1"	
FSV2[17]	SA25	set to "0"	set to "1"	
FSV2[18]	SA26	set to "0"	set to "1"	
FSV2[19]	SA27	set to "0"	set to "1"	
FSV2[20]	SA28	set to "0"	set to "1"	
FSV2[21]	SA29	set to "0"	set to "1"	
FSV2[22]	SA30	set to "0"	set to "1"	
FSV2[23]	SA31	set to "0"	set to "1"	
FSV2[24]	SA32	set to "0"	set to "1"	
FSV2[25]	SA33	set to "0"	set to "1"	
FSV2[26]	SA34	set to "0"	set to "1"	
FSV2[27]	SA35	set to "0"	set to "1"	
FSV2[28]	SA36	set to "0"	set to "1"	
FSV2[29]	SA37	set to "0"	set to "1"	
FSV2[30]	SA38	set to "0"	set to "1"	
FSV2[31]	SA39	set to "0"	set to "1"	

Note : See section "Flash access in CPU mode" for an overview about the sector organisation of the Flash Memory.

7. Notes About Flash Memory CRC Calculation

The Flash Security macro contains a feature to calculate the 32-bit checksum over addresses located in the Flash Memory address space. This feature is described in the MB91460 Series Hardware Manual, chapter 55.4.1 “Flash Security Control Register”.

Additional notes are given here:

The CRC calculation runs on the internal RC clock. It is recommended to switch the RC clock frequency to 2 MHz for shortening the calculation time. However, the CPU clock (CLKB) must be faster than RC clock, otherwise the CRC calculation may not start correctly.

MB91460Q Series

■ MEMORY SPACE

The FR family has 4 Gbytes of logical address space (2^{32} addresses) available to the CPU by linear access.

- Direct addressing area

The following address space area is used for I/O.

This area is called direct addressing area, and the address of an operand can be specified directly in an instruction.

The size of directly addressable area depends on the length of the data being accessed as shown below.

Byte data access : 000_H to 0FF_H

Half word access : 000_H to 1FF_H

Word data access : 000_H to 3FF_H

■ MEMORY MAPS

1. MB91F469QA

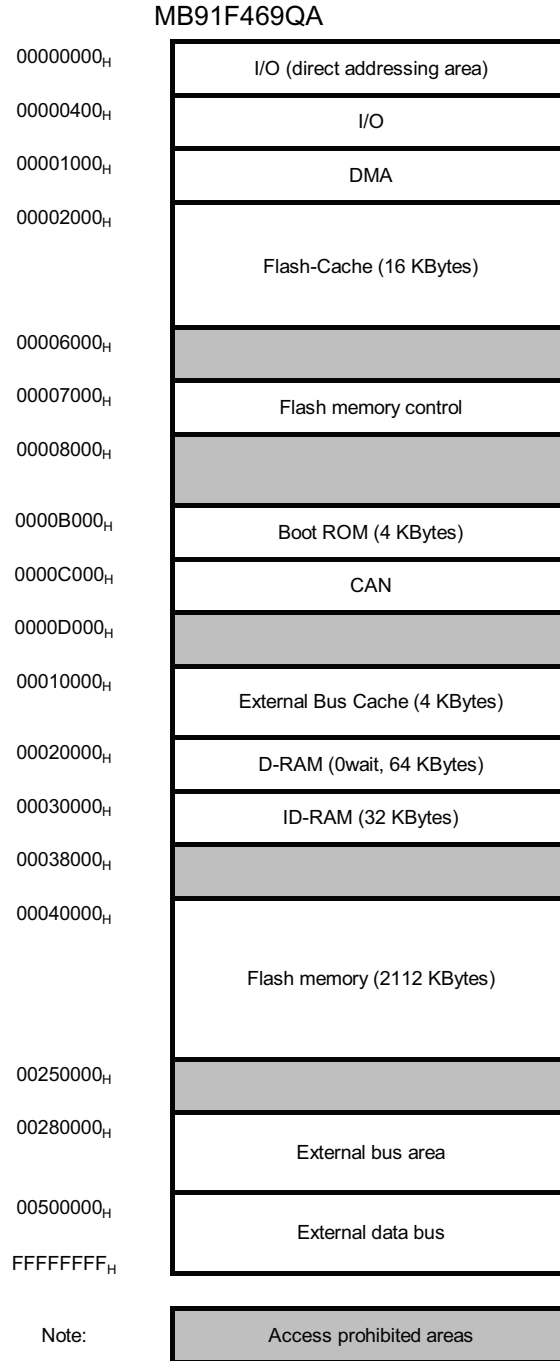

MB91460Q Series

■ I/O MAP

1. MB91F469QA

Address	Register				Block
	+ 0	+ 1	+ 2	+ 3	
000000H	PDR0 [R/W] XXXXXXXX	PDR1 [R/W] XXXXXXXX	PDR2 [R/W] XXXXXXXX	PDR3 [R/W] XXXXXXXX	T-unit port data register

Read/write attribute

Register initial value after reset

Register name (column 1 register at address 4n, column 2 register at address 4n + 1...)

Leftmost register address (for word access, the register in column 1 becomes the MSB side of the data.)

Note : Initial values of register bits are represented as follows:

“ 1 ” : Initial value “ 1 ”

“ 0 ” : Initial value “ 0 ”

“ X ” : Initial value “ undefined ”

“ - ” : No physical register at this location

Access is barred with an undefined data access attribute.

MB91460Q Series

Address	Register				Block
	+0	+1	+2	+3	
00000H	PDR00 [R/W] XXXXXXXX	PDR01 [R/W] XXXXXXXX	PDR02 [R/W] XXXXXXXX	PDR03 [R/W] XXXXXXXX	General Purpose IO Port Data Register
00004H	PDR04 [R/W] ---- XXXX	PDR05 [R/W] XXXXXXXX	PDR06 [R/W] XXXXXXXX	PDR07 [R/W] XXXXXXXX	
00008H	PDR08 [R/W] XXXXXXXX	PDR09 [R/W] XXXXXXXX	PDR10 [R/W] - XXXXXX	PDR11 [R/W] ----- XX	
0000CH	reserved	PDR13 [R/W] XXXXXXXX	PDR14 [R/W] XXXXXXXX	PDR15 [R/W] XXXXXXXX	
00010H	PDR16 [R/W] XXXXXXXX	PDR17 [R/W] XXXXXXXX	PDR18 [R/W] - XXX - XXX	PDR19 [R/W] - XXX - XXX	
00014H	PDR20 [R/W] - XXX - XXX	PDR21 [R/W] - XXX - XXX	PDR22 [R/W] XX -- XX --	PDR23 [R/W] ----- XXXX	
00018H	PDR24 [R/W] XXXXXXXX	reserved	PDR26 [R/W] XXXXXXXX	PDR27 [R/W] XXXXXXXX	
0001CH	PDR28 [R/W] XXXXXXXX	PDR29 [R/W] XXXXXXXX	reserved	reserved	
00020H	reserved	reserved	PDR34 [R/W] -- XX -- XX	PDR35 [R/W] -- XX -- XX	
00024H - 0002CH	reserved				reserved
00030H	EIRR0 [R/W] XXXXXXXX	ENIR0 [R/W] 00000000	ELVR0 [R/W] 00000000 00000000		Ext. INT 0-7 NMI
00034H	EIRR1 [R/W] XXXXXXXX	ENIR1 [R/W] 00000000	ELVR1 [R/W] 00000000 00000000		Ext. INT 8-15
00038H	DICR [R/W] ----- 0	HRCL [R/W] 0 -- 1111	reserved		DLYI/I-unit
0003CH	reserved				reserved
00040H	SCR00 [R/W,W] 00000000	SMR00 [R/W,W] 00000000	SSR00 [R/W,R] 00001000	RDR00/TDR00 [R/W] 00000000	LIN-USART 0
00044H	ESCR00 [R/W] 0000X00	ECCR00 [R/W,R,W] -0000XX	reserved		
00048H	SCR01 [R/W,W] 00000000	SMR01 [R/W,W] 00000000	SSR01 [R/W,R] 00001000	RDR01/TDR01 [R/W] 00000000	LIN-USART 1
0004CH	ESCR01 [R/W] 0000X00	ECCR01 [R/W,R,W] -0000XX	reserved		

MB91460Q Series

Address	Register				Block
	+0	+1	+2	+3	
000050 _H	SCR02 [R/W,W] 00000000	SMR02 [R/W,W] 00000000	SSR02 [R/W,R] 00001000	RDR02/TDR02 [R/W] 00000000	LIN-USART 2
000054 _H	ESCR02 [R/W] 00000X00	ECCR02 [R/W,R,W] -00000XX	reserved		
000058 _H	SCR03[R/W,W] 00000000	SMR03 [R/W,W] 00000000	SSR03 [R/W,R] 00001000	RDR03/TDR02 [R/W] 00000000	LIN-USART 3
00005C _H	ESCR03 [R/W] 00000X00	ECCR03 [R/W,R,W] -00000XX	reserved		
000060 _H	SCR04 [R/W,W] 00000000	SMR04 [R/W,W] 00000000	SSR04 [R/W,R] 00001000	RDR04/TDR04 [R/W] 00000000	LIN-USART 4 with FIFO
000064 _H	ESCR04 [R/W] 00000X00	ECCR04 [R/W,R,W] -00000XX	FSR04 [R] - - - 00000	FCR04 [R/W] 0001 - 000	
000068 _H	SCR05 [R/W,W] 00000000	SMR05 [R/W,W] 00000000	SSR05 [R/W,R] 00001000	RDR05/TDR05 [R/W] 00000000	LIN-USART 5 with FIFO
00006C _H	ESCR05 [R/W] 00000X00	ECCR05 [R/W,R,W] -00000XX	FSR05 [R] - - - 00000	FCR05 [R/W] 0001 - 000	
000070 _H	SCR06 [R/W,W] 00000000	SMR06 [R/W,W] 00000000	SSR06 [R/W,R] 00001000	RDR06/TDR06 [R/W] 00000000	LIN-USART 6 with FIFO
000074 _H	ESCR06 [R/W] 00000X00	ECCR06 [R/W,R,W] -00000XX	FSR06 [R] - - - 00000	FCR06 [R/W] 0001 - 000	
000078 _H	SCR07 [R/W,W] 00000000	SMR07 [R/W,W] 00000000	SSR07 [R/W,R] 00001000	RDR07/TDR07 [R/W] 00000000	LIN-USART 7 with FIFO
00007C _H	ESCR07 [R/W] 00000X00	ECCR07 [R/W,R,W] -00000XX	FSR07 [R] - - - 00000	FCR07 [R/W] 0001 - 000	
000080 _H	BGR100 [R/W] 00000000	BGR000 [R/W] 00000000	BGR101 [R/W] 00000000	BGR001 [R/W] 00000000	Baudrate Generator LIN-USART 0-7
000084 _H	BGR102 [R/W] 00000000	BGR002 [R/W] 00000000	BGR103 [R/W] 00000000	BGR003 [R/W] 00000000	
000088 _H	BGR104 [R/W] 00000000	BGR004 [R/W] 00000000	BGR105 [R/W] 00000000	BGR005 [R/W] 00000000	
00008C _H	BGR106 [R/W] 00000000	BGR006 [R/W] 00000000	BGR107 [R/W] 00000000	BGR007 [R/W] 00000000	

MB91460Q Series

Address	Register				Block
	+0	+1	+2	+3	
000090 _H - 0000CC _H	reserved				reserved
0000D0 _H - 0000D8 _H	reserved				reserved
0000DC _H	IBCR1 [R/W] 00000000	IBSR1 [R] 00000000	ITBAH1 [R/W] ----- 00	ITBAL1 [R/W] 00000000	I2C 1
0000E0 _H	ITMKH1 [R/W] 00 ---- 11	ITMKL1 [R/W] 11111111	ISMK1 [R/W] 01111111	ISBA1 [R/W] - 00000000	
0000E4 _H	reserved	IDAR1 [R/W] 00000000	ICCR1 [R/W] 00011111	reserved	
0000E8 _H - 0000FC _H	reserved				reserved
000100 _H	GCN10 [R/W] 00110010 00010000		reserved	GCN20 [R/W] ---- 0000	PPG Control 0-3
000104 _H	GCN11 [R/W] 00110010 00010000		reserved	GCN21 [R/W] ---- 0000	PPG Control 4-7
000108 _H	GCN12 [R/W] 00110010 00010000		reserved	GCN22 [R/W] ---- 0000	PPG Control 8-11
00010C _H	reserved				reserved
000110 _H	PTMR00 [R] 11111111 11111111		PCSR00 [W] XXXXXXXX XXXXXXXX		PPG 0
000114 _H	PDUT00 [W] XXXXXXXX XXXXXXXX		PCNH00 [R/W] 0000000 -	PCNL00 [R/W] 000000 - 0	
000118 _H	PTMR01 [R] 11111111 11111111		PCSR01 [W] XXXXXXXX XXXXXXXX		PPG 1
00011C _H	PDUT01 [W] XXXXXXXX XXXXXXXX		PCNH01 [R/W] 0000000 -	PCNL01 [R/W] 000000 - 0	
000120 _H	PTMR02 [R] 11111111 11111111		PCSR02 [W] XXXXXXXX XXXXXXXX		PPG 2
000124 _H	PDUT02 [W] XXXXXXXX XXXXXXXX		PCNH02 [R/W] 0000000 -	PCNL02 [R/W] 000000 - 0	
000128 _H	PTMR03 [R] 11111111 11111111		PCSR03 [W] XXXXXXXX XXXXXXXX		PPG 3
00012C _H	PDUT03 [W] XXXXXXXX XXXXXXXX		PCNH03 [R/W] 0000000 -	PCNL03 [R/W] 000000 - 0	
000130 _H	PTMR04 [R] 11111111 11111111		PCSR04 [W] XXXXXXXX XXXXXXXX		PPG 4
000134 _H	PDUT04 [W] XXXXXXXX XXXXXXXX		PCNH04 [R/W] 0000000 -	PCNL04 [R/W] 000000 - 0	

MB91460Q Series

Address	Register				Block
	+0	+1	+2	+3	
000138 _H	PTMR05 [R] 11111111 11111111		PCSR05 [W] XXXXXXXX XXXXXXXX		PPG 5
00013C _H	PDUT05 [W] XXXXXXXX XXXXXXXX		PCNH05 [R/W] 0000000 -	PCNL05 [R/W] 000000 - 0	
000140 _H	PTMR06 [R] 11111111 11111111		PCSR06 [W] XXXXXXXX XXXXXXXX		PPG 6
000144 _H	PDUT06 [W] XXXXXXXX XXXXXXXX		PCNH06 [R/W] 0000000 -	PCNL06 [R/W] 000000 - 0	
000148 _H	PTMR07 [R] 11111111 11111111		PCSR07 [W] XXXXXXXX XXXXXXXX		PPG 7
00014C _H	PDUT07 [W] XXXXXXXX XXXXXXXX		PCNH07 [R/W] 0000000 -	PCNL07 [R/W] 000000 - 0	
000150 _H	PTMR08 [R] 11111111 11111111		PCSR08 [W] XXXXXXXX XXXXXXXX		PPG 8
000154 _H	PDUT08 [W] XXXXXXXX XXXXXXXX		PCNH08 [R/W] 0000000 -	PCNL08 [R/W] 000000 - 0	
000158 _H	PTMR09 [R] 11111111 11111111		PCSR09 [W] XXXXXXXX XXXXXXXX		PPG 9
00015C _H	PDUT09 [W] XXXXXXXX XXXXXXXX		PCNH09 [R/W] 0000000 -	PCNL09 [R/W] 000000 - 0	
000160 _H	PTMR10 [R] 11111111 11111111		PCSR10 [W] XXXXXXXX XXXXXXXX		PPG 10
000164 _H	PDUT10 [W] XXXXXXXX XXXXXXXX		PCNH10 [R/W] 0000000 -	PCNL10 [R/W] 000000 - 0	
000168 _H	PTMR11 [R] 11111111 11111111		PCSR11 [W] XXXXXXXX XXXXXXXX		PPG 11
00016C _H	PDUT11 [W] XXXXXXXX XXXXXXXX		PCNH11 [R/W] 0000000 -	PCNL11 [R/W] 000000 - 0	
000170 _H	P0TMCSRH [R/W] - 0 - 000 - 0	P0TMCSRL [R/W] - - - 00000	P1TMCSRH [R/W] - 0 - 000 - 0	P1TMCSRL [R/W] - - - 00000	Pulse Frequency Modu- lator
000174 _H	P0TMRLR [W] XXXXXXXX XXXXXXXX		P0TMR [R] XXXXXXXX XXXXXXXX		
000178 _H	P1TMRLR [W] XXXXXXXX XXXXXXXX		P1TMR [R] XXXXXXXX XXXXXXXX		
00017C _H	reserved				reserved
000180 _H	reserved	ICS01 [R/W] 00000000	reserved	ICS23 [R/W] 00000000	Input Capture 0-3
000184 _H	IPCP0 [R] XXXXXXXX XXXXXXXX		IPCP1 [R] XXXXXXXX XXXXXXXX		
000188 _H	IPCP2 [R] XXXXXXXX XXXXXXXX		IPCP3 [R] XXXXXXXX XXXXXXXX		

MB91460Q Series

Address	Register				Block
	+0	+1	+2	+3	
00018C _H	OCS01 [R/W] ---0--00 0000--00		OCS23 [R/W] ---0--00 0000--00		Output Compare 0-3
000190 _H	OCCP0 [R/W] XXXXXXXX XXXXXXXX		OCCP1 [R/W] XXXXXXXX XXXXXXXX		
000194 _H	OCCP2 [R/W] XXXXXXXX XXXXXXXX		OCCP3 [R/W] XXXXXXXX XXXXXXXX		
000198 _H	SGCRH [R/W] 0000--00	SGCRL [R/W] --0--000	SGFR [R/W, R] XXXXXXXX XXXXXXXX		Sound Generator
00019C _H	SGAR [R/W] 00000000	reserved	SGTR [R/W] XXXXXXXX	SGDR [R/W] XXXXXXXX	
0001A0 _H	ADERH [R/W] 00000000 00000000		ADERL [R/W] 00000000 00000000		A/D Converter 0
0001A4 _H	ADCS1 [R/W] 00000000	ADCS0 [R/W] 00000000	ADCR1 [R] 000000XX	ADCR0 [R] XXXXXXXX	
0001A8 _H	ADCT1 [R/W] 00010000	ADCT0 [R/W] 00101100	ADSCH [R/W] ---00000	ADECH [R/W] ---00000	
0001AC _H	reserved	ACSR0 [R/W] 011XXX00	reserved	ACSR1 [R/W] 011XXX00	Alarm Comparator 0-1
0001B0 _H	TMRLRC0 [W] XXXXXXXX XXXXXXXX		TMRC0 [R] XXXXXXXX XXXXXXXX		Reload Timer 0 (PPG 0-1)
0001B4 _H	reserved		TMCSRCH0 [R/W] ---00000	TMCSRCL0 [R/W] 0-000000	
0001B8 _H	TMRLRC1 [W] XXXXXXXX XXXXXXXX		TMRC1 [R] XXXXXXXX XXXXXXXX		Reload Timer 1 (PPG 2-3)
0001BC _H	reserved		TMCSRCH1 [R/W] ---00000	TMCSRCL1 [R/W] 0-000000	
0001C0 _H	TMRLRC2 [W] XXXXXXXX XXXXXXXX		TMRC2 [R] XXXXXXXX XXXXXXXX		Reload Timer 2 (PPG 4-5)
0001C4 _H	reserved		TMCSRCH2 [R/W] ---00000	TMCSRCL2 [R/W] 0-000000	
0001C8 _H	TMRLRC3 [W] XXXXXXXX XXXXXXXX		TMRC3 [R] XXXXXXXX XXXXXXXX		Reload Timer 3 (PPG 6-7)
0001CC _H	reserved		TMCSRCH3 [R/W] ---00000	TMCSRCL3 [R/W] 0-000000	

MB91460Q Series

Address	Register				Block
	+0	+1	+2	+3	
0001D0 _H	TMRLRC4 [W] XXXXXXXX XXXXXXXX		TMRC4 [R] XXXXXXXX XXXXXXXX		Reload Timer 4 (PPG 8-9)
0001D4 _H	reserved		TMCSRCH4 [R/W] --- 00000	TMCSRCL4 [R/W] 0 - 000000	
0001D8 _H	TMRLRC5 [W] XXXXXXXX XXXXXXXX		TMRC5 [R] XXXXXXXX XXXXXXXX		Reload Timer 5 (PPG10-11)
0001DC _H	reserved		TMCSRCH5 [R/W] --- 00000	TMCSRL5 [R/W] 0 - 000000	
0001E0 _H	TMRLRC6 [W] XXXXXXXX XXXXXXXX		TMRC6 [R] XXXXXXXX XXXXXXXX		Reload Timer 6 (PPG 12-13)
0001E4 _H	reserved		TMCSRCH6 [R/W] --- 00000	TMCSRL6 [R/W] 0 - 000000	
0001E8 _H	TMRLR7 [W] XXXXXXXX XXXXXXXX		TMRC7 [R] XXXXXXXX XXXXXXXX		Reload Timer 7 (PPG 14-15) (A/D Converter)
0001EC _H	reserved		TMCSRCH7 [R/W] --- 00000	TMCSRCL7 [R/W] 0 - 000000	
0001F0 _H	TCDT0 [R/W] 00000000 00000000		reserved	TCCS0 [R/W] 00000000	Free Running Timer 0 (ICU 0-1)
0001F4 _H	TCDT1 [R/W] 00000000 00000000		reserved	TCCS1 [R/W] 00000000	Free Running Timer 1 (ICU 2-3)
0001F8 _H	TCDT2 [R/W] 00000000 00000000		reserved	TCCS2 [R/W] 00000000	Free Running Timer 2 (OCU 0-1)
0001FC _H	TCDT3 [R/W] 00000000 00000000		reserved	TCCS3 [R/W] 00000000	Free Running Timer 3 (OCU 2-3)
000200 _H	DMACA0 [R/W] 00000000 0000XXXX XXXXXXXX XXXXXXXX				DMAC 0
000204 _H	DMACB0 [R/W] 00000000 00000000 XXXXXXXX XXXXXXXX				
000208 _H	DMACA1 [R/W] 00000000 0000XXXX XXXXXXXX XXXXXXXX				DMAC 1
00020C _H	DMACB1 [R/W] 00000000 00000000 XXXXXXXX XXXXXXXX				

MB91460Q Series

Address	Register				Block
	+0	+1	+2	+3	
000210 _H	DMACA2 [R/W] 00000000 0000XXXX XXXXXXXX XXXXXXXX				DMAC 2
000214 _H	DMACB2 [R/W] 00000000 00000000 XXXXXXXX XXXXXXXX				
000218 _H	DMACA3 [R/W] 00000000 0000XXXX XXXXXXXX XXXXXXXX				DMAC 3
00021C _H	DMACB3 [R/W] 00000000 00000000 XXXXXXXX XXXXXXXX				
000220 _H	DMACA4 [R/W] 00000000 0000XXXX XXXXXXXX XXXXXXXX				DMAC 4
000224 _H	DMACB4 [R/W] 00000000 00000000 XXXXXXXX XXXXXXXX				
000228 _H - 00023C _H	reserved				reserved
000240 _H	DMACR [R/W] 00 - - 0000	reserved			DMAC Control
000244 _H - 00027C _H	reserved				reserved
000280 _H	SCR08 [R/W,W] 00000000	SMR08 [R/W,W] 00000000	SSR08 [R/W,R] 00001000	RDR08/TDR08 [R/W] 00000000	LIN-USART (FIFO) 8
000284 _H	ESCR08 [R/W] 0000X00	ECCR08 [R/W,R,W] -0000XX	FSR08 [R] - - - 00000	FCR08 [R/W] 0001 - 000	
000288 _H	SCR09 [R/W,W] 00000000	SMR09 [R/W,W] 00000000	SSR09 [R/W,R] 00001000	RDR09/TDR09 [R/W] 00000000	LIN-USART (FIFO) 9
00028C _H	ESCR09 [R/W] 0000X00	ECCR09 [R/W,R,W] -0000XX	FSR09 [R] - - - 00000	FCR09 [R/W] 0001 - 000	
000290 _H	SCR10 [R/W,W] 00000000	SMR10 [R/W,W] 00000000	SSR10 [R/W,R] 00001000	RDR10/TDR10 [R/W] 00000000	LIN-USART (FIFO) 10
000294 _H	ESCR10 [R/W] 0000X00	ECCR10 [R/W,R,W] -0000XX	FSR10 [R] - - - 00000	FCR10 [R/W] 0001 - 000	
000298 _H	SCR11 [R/W,W] 00000000	SMR11 [R/W,W] 00000000	SSR11 [R/W,R] 00001000	RDR11/TDR11 [R/W] 00000000	LIN-USART (FIFO) 11
00029C _H	ESCR11 [R/W] 0000X00	ECCR11 [R/W,R,W] -0000XX	FSR11 [R] - - - 00000	FCR11 [R/W] 0001 - 000	

MB91460Q Series

Address	Register				Block
	+0	+1	+2	+3	
0002A0 _H - 0002BC _H	reserved				reserved
0002C0 _H	BGR108 [R/W] 00000000	BGR008 [R/W] 00000000	BGR109 [R/W] 00000000	BGR009 [R/W] 00000000	Baudrate Generator LIN-USART 8-11
0002C4 _H	BGR110 [R/W] 00000000	BGR010 [R/W] 00000000	BGR111 [R/W] 00000000	BGR011 [R/W] 00000000	
0002C8 _H - 0002CC _H	reserved				reserved
0002D0 _H	reserved	ICS45 [R/W] 00000000	reserved	ICS67 [R/W] 00000000	Input Capture 4-7
0002D4 _H	IPCP4 [R] XXXXXXXX XXXXXXXX		IPCP5 [R] XXXXXXXX XXXXXXXX		
0002D8 _H	IPCP6 [R] XXXXXXXX XXXXXXXX		IPCP7 [R] XXXXXXXX XXXXXXXX		
0002DC _H	OCS45 [R/W] --0--00 0000--00		OCS67 [R/W] --0--00 0000--00		Output Compare 4-7
0002E0 _H	OCCP4 [R/W] XXXXXXXX XXXXXXXX		OCCP5 [R/W] XXXXXXXX XXXXXXXX		
0002E4 _H	OCCP6 [R/W] XXXXXXXX XXXXXXXX		OCCP7 [R/W] XXXXXXXX XXXXXXXX		
0002E8 _H - 0002EC _H	reserved				reserved
0002F0 _H	TCDT4 [R/W] 00000000 00000000		reserved	TCCS4 [R/W] 00000000	Free Running Timer 4 (ICU 4-5)
0002F4 _H	TCDT5 [R/W] 00000000 00000000		reserved	TCCS5 [R/W] 00000000	Free Running Timer 5 (ICU 6-7)
0002F8 _H	TCDT6 [R/W] 00000000 00000000		reserved	TCCS6 [R/W] 00000000	Free Running Timer 6 (OCU 4-5)
0002FC _H	TCDT7 [R/W] 00000000 00000000		reserved	TCCS7 [R/W] 00000000	Free Running Timer 7 (OCU 6-7)
000300 _H	UDRC1 [W] 00000000	UDRC0 [W] 00000000	UDCR1 [R] 00000000	UDCR0 [R] 00000000	Up/Down Counter 0-1
000304 _H	UDCCH0 [R/W] 00000000	UDCCL0 [R/W] 00001000	reserved	UDCS0 [R/W] 00000000	
000308 _H	UDCCH1 [R/W] 00000000	UDCCL1 [R/W] 00001000	reserved	UDCS1 [R/W] 00000000	

MB91460Q Series

Address	Register				Block
	+0	+1	+2	+3	
00030C _H	reserved				reserved
000310 _H	UDRC3 [W] 00000000	UDRC2 [W] 00000000	UDCR3 [R] 00000000	UDCR2 [R] 00000000	Up/Down Counter 2-3
000314 _H	UDCCH2 [R/W] 00000000	UDCCL2 [R/W] 00001000	reserved	UDCS2 [R/W] 00000000	
000318 _H	UDCCH3 [R/W] 00000000	UDCCL3 [R/W] 00001000	reserved	UDCS3 [R/W] 00000000	
00031C _H	reserved				reserved
000320 _H	GCN13 [R/W] 00110010 00010000		reserved	GCN23 [R/W] - - - - 0000	PPG Control 12-15
000324 _H - 00032C _H	reserved				reserved
000330 _H	PTMR12 [R] 11111111 11111111		PCSR12 [W] XXXXXXXX XXXXXXXX		PPG 12
000334 _H	PDUT12 [W] XXXXXXXX XXXXXXXX		PCNH12 [R/W] 0000000 -	PCNL12 [R/W] 000000 - 0	
000338 _H	PTMR13 [R] 11111111 11111111		PCSR13 [W] XXXXXXXX XXXXXXXX		PPG 13
00033C _H	PDUT13 [W] XXXXXXXX XXXXXXXX		PCNH13 [R/W] 0000000 -	PCNL13 [R/W] 000000 - 0	
000340 _H	PTMR14 [R] 11111111 11111111		PCSR14 [W] XXXXXXXX XXXXXXXX		PPG 14
000344 _H	PDUT14 [W] XXXXXXXX XXXXXXXX		PCNH14 [R/W] 0000000 -	PCNL14 [R/W] 000000 - 0	
000348 _H	PTMR15 [R] 11111111 11111111		PCSR15 [W] XXXXXXXX XXXXXXXX		PPG 15
00034C _H	PDUT15 [W] XXXXXXXX XXXXXXXX		PCNH15 [R/W] 0000000 -	PCNL15 [R/W] 000000 - 0	
000350 _H - 000364 _H	reserved				reserved
000368 _H	IBCR2 [R/W] 00000000	IBSR2 [R] 00000000	ITBAH2 [R/W] - - - - - 00	ITBAL2 [R/W] 00000000	I2C 2
00036C _H	ITMKH2 [R/W] 00 - - - - 11	ITMKL2 [R/W] 11111111	ISMK2 [R/W] 01111111	ISBA2 [R/W] - 0000000	
000370 _H	reserved	IDAR2 [R/W] 00000000	ICCR2 [R/W] 00011111	reserved	

MB91460Q Series

Address	Register				Block
	+0	+1	+2	+3	
000374 _H	IBCR3 [R/W] 00000000	IBSR3 [R] 00000000	ITBAH3 [R/W] ----- 00	ITBAL3 [R/W] 00000000	I2C 3
000378 _H	ITMKH3 [R/W] 00 ---- 11	ITMKL3 [R/W] 11111111	ISMK3 [R/W] 01111111	ISBA3 [R/W] - 00000000	
00037C _H	reserved	IDAR3 [R/W] 00000000	ICCR3 [R/W] 00011111	reserved	
000380 _H - 00038C _H	reserved				reserved
000390 _H	ROMS [R] 11111000 00000000		reserved		ROM Select register
000394 _H - 0003BC _H	reserved				reserved
0003C0 _H	reserved				I-Cache
0003C4 _H	reserved			ISIZE [R/W] ----- 10	
0003C8 _H - 0003E0 _H	reserved				reserved
0003E4 _H	reserved			ICHCR [R/W] 0 - 000000	I-Cache
0003E8 _H - 0003EC _H	reserved				reserved
0003F0 _H	BSD0 [W] XXXXXXXX XXXXXXXX XXXXXXXX XXXXXXXX				Bit Search Module
0003F4 _H	BSD1 [R/W] XXXXXXXX XXXXXXXX XXXXXXXX XXXXXXXX				
0003F8 _H	BSDC [W] XXXXXXXX XXXXXXXX XXXXXXXX XXXXXXXX				
0003FC _H	BSRR [R] XXXXXXXX XXXXXXXX XXXXXXXX XXXXXXXX				
000400 _H - 00043C _H	reserved				reserved

MB91460Q Series

Address	Register				Block
	+0	+1	+2	+3	
000440 _H	ICR00 [R/W] --- 11111	ICR01 [R/W] --- 11111	ICR02 [R/W] --- 11111	ICR03 [R/W] --- 11111	Interrupt Control register
000444 _H	ICR04 [R/W] --- 11111	ICR05 [R/W] --- 11111	ICR06 [R/W] --- 11111	ICR07 [R/W] --- 11111	
000448 _H	ICR08 [R/W] --- 11111	ICR09 [R/W] --- 11111	ICR10 [R/W] --- 11111	ICR11 [R/W] --- 11111	
00044C _H	ICR12 [R/W] --- 11111	ICR13 [R/W] --- 11111	ICR14 [R/W] --- 11111	ICR15 [R/W] --- 11111	
000450 _H	ICR16 [R/W] --- 11111	ICR17 [R/W] --- 11111	ICR18 [R/W] --- 11111	ICR19 [R/W] --- 11111	
000454 _H	ICR20 [R/W] --- 11111	ICR21 [R/W] --- 11111	ICR22 [R/W] --- 11111	ICR23 [R/W] --- 11111	
000458 _H	ICR24 [R/W] --- 11111	ICR25 [R/W] --- 11111	ICR26 [R/W] --- 11111	ICR27 [R/W] --- 11111	
00045C _H	ICR28 [R/W] --- 11111	ICR29 [R/W] --- 11111	ICR30 [R/W] --- 11111	ICR31 [R/W] --- 11111	
000460 _H	ICR32 [R/W] --- 11111	ICR33 [R/W] --- 11111	ICR34 [R/W] --- 11111	ICR35 [R/W] --- 11111	
000464 _H	ICR36 [R/W] --- 11111	ICR37 [R/W] --- 11111	ICR38 [R/W] --- 11111	ICR39 [R/W] --- 11111	
000468 _H	ICR40 [R/W] --- 11111	ICR41 [R/W] --- 11111	ICR42 [R/W] --- 11111	ICR43 [R/W] --- 11111	
00046C _H	ICR44 [R/W] --- 11111	ICR45 [R/W] --- 11111	ICR46 [R/W] --- 11111	ICR47 [R/W] --- 11111	
000470 _H	ICR48 [R/W] --- 11111	ICR49 [R/W] --- 11111	ICR50 [R/W] --- 11111	ICR51 [R/W] --- 11111	
000474 _H	ICR52 [R/W] --- 11111	ICR53 [R/W] --- 11111	ICR54 [R/W] --- 11111	ICR55 [R/W] --- 11111	
000478 _H	ICR56 [R/W] --- 11111	ICR57 [R/W] --- 11111	ICR58 [R/W] --- 11111	ICR59 [R/W] --- 11111	
00047C _H	ICR60 [R/W] --- 11111	ICR61 [R/W] --- 11111	ICR62 [R/W] --- 11111	ICR63 [R/W] --- 11111	
000480 _H	RSRR [R/W] 10000000	STCR [R/W] 00110011	TBCR [R/W] 00XXX – 00	CTBR [W] XXXXXXXXXX	Clock Control Unit
000484 _H	CLKR [R/W] ---- 0000	WPR [W] XXXXXXXXXX	DIVR0 [R/W] 00000011	DIVR1 [R/W] 00000000	
000488 _H	reserved				reserved
00048C _H	PLLDIVM [R/W] ---- 0000	PLLDIVN [R/W] -- 000000	PLLDIVG [R/W] ---- 0000	PLLMULG [W] 00000000	PLL Clock Gear Unit
000490 _H	PLLCTRL [R/W] ---- 0000	reserved			

MB91460Q Series

Address	Register				Block
	+0	+1	+2	+3	
000494 _H	OSCC1 [R/W] ----- 010	OSCS1 [R/W] 00001111	OSCC2 [R/W] ----- 010	OSCS2 [R/W] 00001111	Main/Sub Oscillator Control
000498 _H	PORTEN [R/W] ----- 00	reserved			Port Input Enable Control
00049C _H	reserved				reserved
0004A0 _H	reserved	WTCR [R/W] ----- 00	WTCR [R/W] 00000000 000 - 00 - 0		Watchdog Timer
0004A4 _H	reserved	WTBR [R/W] --- XXXXX XXXXXXXX XXXXXXXX			
0004A8 _H	WTHR [R/W] --- 00000	WTMR [R/W] -- 000000	WTSR [R/W] -- 000000	reserved	
0004AC _H	CSVTR [R/W] --- 00010	CSVCR [R/W] 00011100	CSCFG [R/W] 0X000000	CMCFG [R/W] 00000000	Clock- Supervisor / Se- lector / Monitor
0004B0 _H	CUCR [R/W] ----- 0 -- 00		CUTD [R/W] 10000000 00000000		Calibration Unit of Sub Oscillation
0004B4 _H	CUTR1 [R] ----- 00000000		CUTR2 [R] 00000000 00000000		
0004B8 _H	CMPR [R/W] -- 000010 11111101		reserved	CMCR [R/W] - 001 -- 00	Clock Modulation
0004BC _H	CMT1 [R/W] 00000000 1 --- 0000		CMT2 [R/W] -- 000000 -- 000000		
0004C0 _H	CANPRE [R/W] 0 --- 0000	CANCKD [R/W] -- 0 --- 00 ¹	reserved		CAN Clock Con- trol
0004C4 _H	LVSEL [R/W] 00000111	LVDET [R/W] -000 0 - 00	HWWE [R/W] ----- 00	HWWD [R/W,W] 00011000	LV Detection / Hardware- Watchdog
0004C8 _H	OSCRH [R/W] 000 -- 001	OSCRL [R/W] ----- 000	WPCRH [R/W] 000 -- 000	WPCRL [R/W] ----- 00	Main-/Sub-Oscil- lation Stabilisa- tion Timer
0004CC _H	OSCCR [R/W] ----- 00	reserved	REGSEL [R/W] -- 000110	REGCTR [R/W] --- X -- 00	Main- Oscillation Standby Control Main/Sub Regula- tor Control
0004D0 _H - 0005DC _H	reserved				reserved

MB91460Q Series

Address	Register				Block
	+0	+1	+2	+3	
0005E0 _H	AD1ERH [R/W] 00000000 00000000		AD1ERL [R/W] 00000000 00000000		A/D Converter 1
0005E4 _H	AD1CS1 [R/W] 00000000	AD1CS0 [R/W] 00000000	AD1CR1 [R] 000000XX	AD1CR0 [R] XXXXXXXX	
0005E8 _H	AD1CT1 [R/W] 00010000	AD1CT0 [R/W] 00101100	AD1SCH [R/W] --- 00000	AD1ECH [R/W] --- 00000	
0005EC _H	reserved				
0005F0 _H	reserved	ICS89 [R/W] 00000000	reserved	reserved	Input Capture 8-9
0005F4 _H	IPCP8 [R] XXXXXXXXXX XXXXXXXXXX		IPCP9 [R] XXXXXXXXXX XXXXXXXXXX		
0005F8 _H	reserved		reserved		
0005FC _H - 000604 _H	reserved				reserved
000608 _H	TCDT8 [R/W] 00000000 00000000		reserved	TCCS8 [R/W] 00000000	Free Running Timer 8 (ICU 8-9)
00060C _H - 00063C _H	reserved				reserved

MB91460Q Series

Address	Register				Block
	+0	+1	+2	+3	
000640 _H	ASR0 [R/W] 00000000 00000000		ACR0 [R/W] 1111**00 00100000 ²		External Bus Unit
000644 _H	ASR1 [R/W] XXXXXXXX XXXXXXXX		ACR1 [R/W] XXXXXXXX XXXXXXXX		
000648 _H	ASR2 [R/W] XXXXXXXX XXXXXXXX		ACR2 [R/W] XXXXXXXX XXXXXXXX		
00064C _H	ASR3 [R/W] XXXXXXXX XXXXXXXX		ACR3 [R/W] XXXXXXXX XXXXXXXX		
000650 _H	ASR4 [R/W] XXXXXXXX XXXXXXXX		ACR4 [R/W] XXXXXXXX XXXXXXXX		
000654 _H	ASR5 [R/W] XXXXXXXX XXXXXXXX		ACR5 [R/W] XXXXXXXX XXXXXXXX		
000658 _H	ASR6 [R/W] XXXXXXXX XXXXXXXX		ACR6 [R/W] XXXXXXXX XXXXXXXX		
00065C _H	ASR7 [R/W] XXXXXXXX XXXXXXXX		ACR7 [R/W] XXXXXXXX XXXXXXXX		
000660 _H	AWR0 [R/W] 01111111 11111011		AWR1 [R/W] XXXXXXXX XXXXXXXX		
000664 _H	AWR2 [R/W] XXXXXXXX XXXXXXXX		AWR3 [R/W] XXXXXXXX XXXXXXXX		
000668 _H	AWR4 [R/W] XXXXXXXX XXXXXXXX		AWR5 [R/W] XXXXXXXX XXXXXXXX		
00066C _H	AWR6 [R/W] XXXXXXXX XXXXXXXX		AWR7 [R/W] XXXXXXXX XXXXXXXX		
000670 _H	MCRA [R/W] XXXXXXXX	MCRB [R/W] XXXXXXXX	reserved		
000674 _H	reserved				
000678 _H	IOWR0 [R/W] XXXXXXXX	IOWR1 [R/W] XXXXXXXX	IOWR2 [R/W] XXXXXXXX	IOWR3 [R/W] XXXXXXXX	
00067C _H	reserved				
000680 _H	CSER [R/W] 00000001	CHER [R/W] 11111111	reserved	TCR [R/W] 0000**** ³	
000684 _H	RCRH [R/W] 00XXXXXX	RCRL [R/W] XXXX0XXX	reserved		
000688 _H - 0007F8 _H	reserved				reserved
0007FC _H	reserved	MODR [W] XXXXXXXX	reserved		Mode Register
000800 _H - 000BFC _H	reserved				reserved

MB91460Q Series

Address	Register				Block
	+0	+1	+2	+3	
000C00 _H	reserved			IOS [R/W] *4 -----10	I-Unit
000C04 _H	EIRR2 [R/W] XXXXXXXX	ENIR2 [R/W] 00000000	ELVR2 [R/W] 00000000 00000000		Ext. INT 16-23
000C08 _H	EIRR3 [R/W] XXXXXXXX	ENIR3 [R/W] 00000000	ELVR3 [R/W] 00000000 00000000		Ext. INT 24-31
000C0C _H - 000FC _H	reserved				reserved
000D00 _H	PDRD00 [R] XXXXXXXX	PDRD01 [R] XXXXXXXX	PDRD02 [R] XXXXXXXX	PDRD03 [R] XXXXXXXX	General IO Port Direct Read Data register
000D04 _H	PDRD04 [R] ----XXXX	PDRD05 [R] XXXXXXXX	PDRD06 [R] XXXXXXXX	PDRD07 [R] XXXXXXXX	
000D08 _H	PDRD08 [R] XXXXXXXX	PDRD09 [R] XXXXXXXX	PDRD10 [R] -XXXXXX	PDRD11 [R] -----XX	
000D0C _H	reserved	PDRD13 [R] XXXXXXXX	PDRD14 [R] XXXXXXXX	PDRD15 [R] XXXXXXXX	
000D10 _H	PDRD16 [R] XXXXXXXX	PDRD17 [R] XXXXXXXX	PDRD18 [R] -XXX-XXX	PDRD19 [R] -XXX-XXX	
000D14 _H	PDRD20 [R] -XXX-XXX	PDRD21 [R] -XXX-XXX	PDRD22 [R] XX--XX--	PDRD23 [R] ----XXXX	
000D18 _H	PDRD24 [R] XXXXXXXX	reserved	PDRD26 [R] XXXXXXXX	PDRD27 [R] XXXXXXXX	
000D1C _H	PDRD28 [R] XXXXXXXX	PDRD29 [R] XXXXXXXX	reserved		
000D20 _H	reserved	reserved	PDRD34 [R] --XX--XX	PDRD35 [R] --XX--XX	
000D24 _H - 000D3C _H	reserved				reserved

MB91460Q Series

Address	Register				Block
	+0	+1	+2	+3	
000D40 _H	DDR00 [R/W] 00000000	DDR01 [R/W] 00000000	DDR02 [R/W] 00000000	DDR03 [R/W] 00000000	General IO Port Data Direction register
000D44 _H	DDR04 [R/W] ---- 0000	DDR05 [R/W] 00000000	DDR06 [R/W] 00000000	DDR07 [R/W] 00000000	
000D48 _H	DDR08 [R/W] 00000000	DDR09 [R/W] 00000000	DDR10 [R/W] - 0000000	DDR11 [R/W] ----- 00	
000D4C _H	reserved	DDR13 [R/W] 00000000	DDR14 [R/W] 00000000	DDR15 [R/W] 00000000	
000D50 _H	DDR16 [R/W] 00000000	DDR17 [R/W] 00000000	DDR18 [R/W] - 000 - 000	DDR19 [R/W] - 000 - 000	
000D54 _H	DDR20 [R/W] - 000 - 000	DDR21 [R/W] - 000 - 000	DDR22 [R/W] 00 -- 00 --	DDR23 [R/W] ---- 0000	
000D58 _H	DDR24 [R/W] 00000000	reserved	DDR26 [R/W] 00000000	DDR27 [R/W] 00000000	
000D5C _H	DDR28 [R/W] 00000000	DDR29 [R/W] 00000000	reserved		
000D60 _H	reserved	reserved	DDR34 [R/W] -- 00 -- 00	DDR35 [R/W] -- 00 -- 00	
000D64 _H - 000D7C _H	reserved				reserved
000D80 _H	PFR00 [R/W] 00000000 ⁵ 11111111	PFR01 [R/W] 00000000 ⁵ 11111111	PFR02 [R/W] 00000000 ⁵ 11111111	PFR03 [R/W] 00000000 ⁵ 11111111	Port Function reg- ister
000D84 _H	PFR04 [R/W] --- 0000 ⁵ ---- 1111	PFR05 [R/W] 00000000 ⁵ 11111111	PFR06 [R/W] 00000000 ⁵ 11111111	PFR07 [R/W] 00000000 ⁵ 11111111	
000D88 _H	PFR08 [R/W] 00000000 ⁵ 11111111	PFR09 [R/W] 00000000 ⁵ 11111111	PFR10 [R/W] -0000000 ⁵ -11111111	PFR11 [R/W] ----- 00	
000D8C _H	reserved	PFR13 [R/W] 00000000	PFR14 [R/W] 00000000	PFR15 [R/W] 00000000	
000D90 _H	PFR16 [R/W] 00000000	PFR17 [R/W] 00000000	PFR18 [R/W] - 000 - 000	PFR19 [R/W] - 000 - 000	
000D94 _H	PFR20 [R/W] - 000 - 000	PFR21 [R/W] - 000 - 000	PFR22 [R/W] 00 -- 00 --	PFR23 [R/W] ---- 0000	
000D98 _H	PFR24 [R/W] 00000000	reserved	PFR26 [R/W] 00000000	PFR27 [R/W] 00000000	
000D9C _H	PFR28 [R/W] 00000000	PFR29 [R/W] 00000000	reserved		
000DA0 _H	reserved	reserved	PFR34 [R/W] -- 00 -- 00	PFR35 [R/W] -- 00 -- 00	

MB91460Q Series

Address	Register				Block
	+0	+1	+2	+3	
000DA4 _H - 000DC4 _H	reserved				reserved
000DC8 _H	reserved		EPFR10 [R/W] -- 00 --- 0	reserved	Extended Port Function register
000DCC _H	reserved	EPFR13 [R/W] - 0 --- 0 --	EPFR14 [R/W] 00000000	EPFR15 [R/W] 00000000	
000DD0 _H	EPFR16 [R/W] 0000 - - - -	reserved	EPFR18 [R/W] - 000 - 000	EPFR19 [R/W] - 0 - - - 0 - -	
000DD4 _H	EPFR20 [R/W] - 000 - 000	EPFR21 [R/W] - 0 - - - 0 - -	reserved		
000DD8 _H	reserved		EPFR26 [R/W] 00000000	EPFR27 [R/W] 00000000	
000DDC _H	reserved				
000DE0 _H	reserved		EPFR34 [R/W] -- 00 -- 00	EPFR35 [R/W] -- 00 -- 00	
000DE4 _H - 000DFC _H	reserved				reserved
000E00 _H	PODR00 [R/W] 00000000	PODR01 [R/W] 00000000	PODR02 [R/W] 00000000	PODR03 [R/W] 00000000	Port Output Drive Strength control
000E04 _H	PODR04 [R/W] - - - - 0000	PODR05 [R/W] 00000000	PODR06 [R/W] 00000000	PODR07 [R/W] 00000000	
000E08 _H	PODR08 [R/W] 00000000	PODR09 [R/W] 00000000	PODR10 [R/W] - 0000000	PODR11 [R/W] - - - - - 00	
000E0C _H	reserved	PODR13 [R/W] 00000000	PODR14 [R/W] 00000000	PODR15 [R/W] 00000000	
000E10 _H	PODR16 [R/W] 00000000	PODR17 [R/W] 00000000	PODR18 [R/W] - 000 - 000	PODR19 [R/W] - 000 - 000	
000E14 _H	PODR20 [R/W] - 000 - 000	PODR21 [R/W] - 000 - 000	PODR22 [R/W] 00 - - 00 - -	PODR23 [R/W] - - - - 0000	
000E18 _H	PODR24 [R/W] 00000000	reserved	PODR26 [R/W] 00000000	PODR27 [R/W] 00000000	
000E1C _H	PODR28 [R/W] 00000000	PODR29 [R/W] 00000000	reserved		
000E20 _H	reserved	reserved	PODR34 [R/W] -- 00 -- 00	PODR35 [R/W] -- 00 -- 00	
000E24 _H - 000E3C _H	reserved				reserved

MB91460Q Series

Address	Register				Block
	+0	+1	+2	+3	
000E40 _H	PILR00 [R/W] 00000000	PILR01 [R/W] 00000000	PILR02 [R/W] 00000000	PILR03 [R/W] 00000000	Port Input Level selection register
000E44 _H	PILR04 [R/W] ---- 0000	PILR05 [R/W] 00000000	PILR06 [R/W] 00000000	PILR07 [R/W] 00000000	
000E48 _H	PILR08 [R/W] 00000000	PILR09 [R/W] 00000000	PILR10 [R/W] - 0000000	PILR11 [R/W] ----- 00	
000E4C _H	reserved	PILR13 [R/W] 00000000	PILR14 [R/W] 00000000	PILR15 [R/W] 00000000	
000E50 _H	PILR16 [R/W] 00000000	PILR17 [R/W] 00000000	PILR18 [R/W] - 000 - 000	PILR19 [R/W] - 000 - 000	
000E54 _H	PILR20 [R/W] - 000 - 000	PILR21 [R/W] - 000 - 000	PILR22 [R/W] 00 -- 00 --	PILR23 [R/W] ---- 0000	
000E58 _H	PILR24 [R/W] 00000000	reserved	PILR26 [R/W] 00000000	PILR27 [R/W] 00000000	
000E5C _H	PILR28 [R/W] 00000000	PILR29 [R/W] 00000000	reserved		
000E60 _H	reserved	reserved	PILR34 [R/W] -- 00 -- 00	PILR35 [R/W] -- 00 -- 00	
000E64 _H - 000E7C _H	reserved				reserved
000E80 _H	EPILR00 [R/W] 00000000	EPILR01 [R/W] 00000000	EPILR02 [R/W] 00000000	EPILR03 [R/W] 00000000	Extended Port In- put Level selec- tion register
000E84 _H	EPILR04 [R/W] ---- 0000	EPILR05 [R/W] 00000000	EPILR06 [R/W] 00000000	EPILR07 [R/W] 00000000	
000E88 _H	EPILR08 [R/W] 00000000	EPILR09 [R/W] 00000000	EPILR10 [R/W] - 0000000	EPILR11 [R/W] ----- 00	
000E8C _H	reserved	EPILR13 [R/W] 00000000	EPILR14 [R/W] 00000000	EPILR15 [R/W] 00000000	
000E90 _H	EPILR16 [R/W] 00000000	EPILR17 [R/W] 00000000	EPILR18 [R/W] - 000 - 000	EPILR19 [R/W] - 000 - 000	
000E94 _H	EPILR20 [R/W] - 000 - 000	EPILR21 [R/W] - 000 - 000	EPILR22 [R/W] 00 -- 00 --	EPILR23 [R/W] ---- 0000	
000E98 _H	EPILR24 [R/W] 00000000	reserved	EPILR26 [R/W] 00000000	EPILR27 [R/W] 00000000	
000E9C _H	EPILR28 [R/W] 00000000	EPILR29 [R/W] 00000000	reserved		
000EA0 _H	reserved	reserved	EPILR34 [R/W] -- 00 -- 00	EPILR35 [R/W] -- 00 -- 00	
000EA4 _H - 000EBC _H	reserved				reserved

MB91460Q Series

Address	Register				Block
	+0	+1	+2	+3	
000EC0 _H	PPER00 [R/W] 00000000	PPER01 [R/W] 00000000	PPER02 [R/W] 00000000	PPER03 [R/W] 00000000	Port Pull-Up/ Down Enable reg- ister
000EC4 _H	PPER04 [R/W] ---- 0000	PPER05 [R/W] 00000000	PPER06 [R/W] 00000000	PPER07 [R/W] 00000000	
000EC8 _H	PPER08 [R/W] 00000000	PPER09 [R/W] 00000000	PPER10 [R/W] - 0000000	PPER11 [R/W] ----- 00	
000ECC _H	reserved	PPER13 [R/W] 00000000	PPER14 [R/W] 00000000	PPER15 [R/W] 00000000	
000ED0 _H	PPER16 [R/W] 00000000	PPER17 [R/W] 00000000	PPER18 [R/W] - 000 - 000	PPER19 [R/W] - 000 - 000	
000ED4 _H	PPER20 [R/W] - 000 - 000	PPER21 [R/W] - 000 - 000	PPER22 [R/W] 00 -- 00 --	PPER23 [R/W] ---- 0000	
000ED8 _H	PPER24 [R/W] 00000000	reserved	PPER26 [R/W] 00000000	PPER27 [R/W] 00000000	
000EDC _H	PPER28 [R/W] 00000000	PPER29 [R/W] 00000000	reserved		
000EE0 _H	reserved	reserved	PPER34 [R/W] -- 00 -- 00	PPER35 [R/W] -- 00 -- 00	
000EE4 _H - 000EFC _H	reserved				reserved
000F00 _H	PPCR00 [R/W] 11111111	PPCR01 [R/W] 11111111	PPCR02 [R/W] 11111111	PPCR03 [R/W] 11111111	Port Pull-Up/ Down Control register
000F04 _H	PPCR04 [R/W] ---- 1111	PPCR05 [R/W] 11111111	PPCR06 [R/W] 11111111	PPCR07 [R/W] 11111111	
000F08 _H	PPCR08 [R/W] 11111111	PPCR09 [R/W] 11111111	PPCR10 [R/W] - 1111111	PPCR11 [R/W] ----- 11	
000F0C _H	reserved	PPCR13 [R/W] 11111111	PPCR14 [R/W] 11111111	PPCR15 [R/W] 11111111	
000F10 _H	PPCR16 [R/W] 11111111	PPCR17 [R/W] 11111111	PPCR18 [R/W] - 111 - 111	PPCR19 [R/W] - 111 - 111	
000F14 _H	PPCR20 [R/W] - 111 - 111	PPCR21 [R/W] - 111 - 111	PPCR22 [R/W] 00 -- 00 --	PPCR23 [R/W] ---- 0000	
000F18 _H	PPCR24 [R/W] 11111111	reserved	PPCR26 [R/W] 11111111	PPCR27 [R/W] 11111111	
000F1C _H	PPCR28 [R/W] 11111111	PPCR29 [R/W] 11111111	reserved		
000F20 _H	reserved	reserved	PPCR34 [R/W] -- 00 -- 00	PPCR35 [R/W] -- 00 -- 00	
000F24 _H - 000FFC _H	reserved				reserved

MB91460Q Series

Address	Register				Block
	+0	+1	+2	+3	
001000 _H	DMASA0 [R/W] XXXXXXXX XXXXXXXX XXXXXXXX XXXXXXXX				DMAC
001004 _H	DMADA0 [R/W] XXXXXXXX XXXXXXXX XXXXXXXX XXXXXXXX				
001008 _H	DMASA1 [R/W] XXXXXXXX XXXXXXXX XXXXXXXX XXXXXXXX				
00100C _H	DMADA1 [R/W] XXXXXXXX XXXXXXXX XXXXXXXX XXXXXXXX				
001010 _H	DMASA2 [R/W] XXXXXXXX XXXXXXXX XXXXXXXX XXXXXXXX				
001014 _H	DMADA2 [R/W] XXXXXXXX XXXXXXXX XXXXXXXX XXXXXXXX				
001018 _H	DMASA3 [R/W] XXXXXXXX XXXXXXXX XXXXXXXX XXXXXXXX				
00101C _H	DMADA3 [R/W] XXXXXXXX XXXXXXXX XXXXXXXX XXXXXXXX				
001020 _H	DMASA4 [R/W] XXXXXXXX XXXXXXXX XXXXXXXX XXXXXXXX				
001024 _H	DMADA4 [R/W] XXXXXXXX XXXXXXXX XXXXXXXX XXXXXXXX				
001028 _H - 01FFC _H	reserved				reserved
002000 _H - 005FFC _H	MB91F469QA Instruction RAM/Flash Cache size is 16KB				Instruction RAM/ Flash Cache
006000 _H - 006FFC _H	reserved				reserved
007000 _H	FMCS [R/W] 01101000	FMCR [R] --- 00000	FCHCR [R/W] ----- 00 10000011		Flash Memory/ F-Cache Control Register
007004 _H	FMWT [R/W] 11111111 11111111		FMWT2 [R] - 001 ----	FMPS [R/W] ----- 000	
007008 _H	FMAC [R] 00000000 00000000 00000000 00000000				
00700C _H	FCHA0 [R/W] ----- -- 000000 00000000 00000000				I-Cache Non- cacheable area setting Register
007010 _H	FCHA1 [R/W] ----- -- 000000 00000000 00000000				
007014 _H - 007FFC _H	reserved				reserved

MB91460Q Series

Address	Register				Block
	+0	+1	+2	+3	
008000 _H - 00BFFC _H	MB91F469QA Boot-ROM size is 4 Kbytes (instruction access is 1 wait cycle, data access is 1 wait cycle)				Boot ROM
00C000 _H	CTRLR0 [R/W] 00000000 00000001		STATR0 [R/W] 00000000 00000000		CAN 0 Control register
00C004 _H	ERRCNT0 [R] 00000000 00000000		BTR0 [R/W] 00100011 00000001		
00C008 _H	INTR0 [R] 00000000 00000000		TESTR0 [R/W] 00000000 X0000000		
00C00C _H	BRPE0 [R/W] 00000000 00000000		reserved		
00C010 _H	IF1CREQ0 [R/W] 00000000 00000001		IF1CMSK0 [R/W] 00000000 00000000		CAN 0 IF 1 Register
00C014 _H	IF1MSK20 [R/W] 11111111 11111111		IF1MSK10 [R/W] 11111111 11111111		
00C018 _H	IF1ARB20 [R/W] 00000000 00000000		IF1ARB10 [R/W] 00000000 00000000		
00C01C _H	IF1MCTR0 [R/W] 00000000 00000000		reserved		
00C020 _H	IF1DTA10 [R/W] 00000000 00000000		IF1DTA20 [R/W] 00000000 00000000		
00C024 _H	IF1DTB10 [R/W] 00000000 00000000		IF1DTB20 [R/W] 00000000 00000000		
00C028 _H - 00C02C _H	reserved				reserved
00C030 _H	IF1DTA20 [R/W] 00000000 00000000		IF1DTA10 [R/W] 00000000 00000000		CAN 0 IF 1 Register mirror
00C034 _H	IF1DTB20 [R/W] 00000000 00000000		IF1DTB10 [R/W] 00000000 00000000		
00C038 _H - 00C03C _H	reserved				reserved

MB91460Q Series

Address	Register				Block
	+0	+1	+2	+3	
00C040 _H	IF2CREQ0 [R/W] 00000000 00000001		IF2CMSK0 [R/W] 00000000 00000000		CAN 0 IF 2 Register
00C044 _H	IF2MSK20 [R/W] 11111111 11111111		IF2MSK10 [R/W] 11111111 11111111		
00C048 _H	IF2ARB20 [R/W] 00000000 00000000		IF2ARB10 [R/W] 00000000 00000000		
00C04C _H	IF2MCTR0 [R/W] 00000000 00000000		reserved		
00C050 _H	IF2DTA10 [R/W] 00000000 00000000		IF2DTA20 [R/W] 00000000 00000000		
00C054 _H	IF2DTB10 [R/W] 00000000 00000000		IF2DTB20 [R/W] 00000000 00000000		
00C058 _H - 00C05C _H	reserved				reserved
00C060 _H	IF2DTA20 [R/W] 00000000 00000000		IF2DTA10 [R/W] 00000000 00000000		CAN 0 IF 2 Register mirror
00C064 _H	IF2DTB20 [R/W] 00000000 00000000		IF2DTB10 [R/W] 00000000 00000000		
00C068 _H - 00C07C _H	reserved				reserved

MB91460Q Series

Address	Register				Block
	+0	+1	+2	+3	
00C080 _H	TREQR20 [R] 00000000 00000000		TREQR10 [R] 00000000 00000000		CAN 0 Status Flags
00C084 _H	TREQR40 [R] 00000000 00000000		TREQR30 [R] 00000000 00000000		
00C088 _H	TREQR60 [R] 00000000 00000000		TREQR50 [R] 00000000 00000000		
00C08C _H	TREQR80 [R] 00000000 00000000		TREQR70 [R] 00000000 00000000		
00C090 _H	NEWDT20 [R] 00000000 00000000		NEWDT10 [R] 00000000 00000000		
00C094 _H	NEWDT40 [R] 00000000 00000000		NEWDT30 [R] 00000000 00000000		
00C098 _H	NEWDT60 [R] 00000000 00000000		NEWDT50 [R] 00000000 00000000		
00C09C _H	NEWDT80 [R] 00000000 00000000		NEWDT70 [R] 00000000 00000000		
00C0A0 _H	INTPND20 [R] 00000000 00000000		INTPND10 [R] 00000000 00000000		
00C0A4 _H	INTPND40 [R] 00000000 00000000		INTPND30 [R] 00000000 00000000		
00C0A8 _H	INTPND60 [R] 00000000 00000000		INTPND50 [R] 00000000 00000000		
00C0AC _H	INTPND80 [R] 00000000 00000000		INTPND70 [R] 00000000 00000000		
00C0B0 _H	MSGVAL20 [R] 00000000 00000000		MSGVAL10 [R] 00000000 00000000		
00C0B4 _H	MSGVAL40 [R] 00000000 00000000		MSGVAL30 [R] 00000000 00000000		
00C0B8 _H	MSGVAL60 [R] 00000000 00000000		MSGVAL50 [R] 00000000 00000000		
00C0BC _H	MSGVAL80 [R] 00000000 00000000		MSGVAL70 [R] 00000000 00000000		
00C0C0 _H - 00C0FC _H	reserved				reserved

MB91460Q Series

Address	Register				Block
	+0	+1	+2	+3	
00C100 _H	CTRLR1 [R/W] 00000000 00000001		STATR1 [R/W] 00000000 00000000		CAN 1 Control Register
00C104 _H	ERRCNT1 [R] 00000000 00000000		BTR1 [R/W] 00100011 00000001		
00C108 _H	INTR1 [R] 00000000 00000000		TESTR1 [R/W] 00000000 X0000000		
00C10C _H	BRPE1 [R/W] 00000000 00000000		reserved		
00C110 _H	IF1CREQ1 [R/W] 00000000 00000001		IF1CMSK1 [R/W] 00000000 00000000		CAN 1 IF 1 Register
00C114 _H	IF1MSK21 [R/W] 11111111 11111111		IF1MSK11 [R/W] 11111111 11111111		
00C118 _H	IF1ARB21 [R/W] 00000000 00000000		IF1ARB11 [R/W] 00000000 00000000		
00C11C _H	IF1MCTR1 [R/W] 00000000 00000000		reserved		
00C120 _H	IF1DTA11 [R/W] 00000000 00000000		IF1DTA21 [R/W] 00000000 00000000		
00C124 _H	IF1DTB11 [R/W] 00000000 00000000		IF1DTB21 [R/W] 00000000 00000000		
00C128 _H - 00C12C _H	reserved				reserved
00C130 _H	IF1DTA21 [R/W] 00000000 00000000		IF1DTA11 [R/W] 00000000 00000000		CAN 1 IF 1 Register mirror
00C134 _H	IF1DTB21 [R/W] 00000000 00000000		IF1DTB11 [R/W] 00000000 00000000		
00C138 _H - 00C13C _H	reserved				reserved
00C140 _H	IF2CREQ1 [R/W] 00000000 00000001		IF2CMSK1 [R/W] 00000000 00000000		CAN 1 IF 2 Register
00C144 _H	IF2MSK21 [R/W] 11111111 11111111		IF2MSK11 [R/W] 11111111 11111111		
00C148 _H	IF2ARB21 [R/W] 00000000 00000000		IF2ARB11 [R/W] 00000000 00000000		
00C14C _H	IF2MCTR1 [R/W] 00000000 00000000		reserved		
00C150 _H	IF2DTA11 [R/W] 00000000 00000000		IF2DTA21 [R/W] 00000000 00000000		
00C154 _H	IF2DTB11 [R/W] 00000000 00000000		IF2DTB21 [R/W] 00000000 00000000		

MB91460Q Series

Address	Register				Block
	+0	+1	+2	+3	
00C158 _H - 00C15C _H	reserved				reserved
00C160 _H	IF2DTA21 [R/W] 00000000 00000000		IF2DTA11 [R/W] 00000000 00000000		CAN 1 IF 2 Register mirror
00C164 _H	IF2DTB21 [R/W] 00000000 00000000		IF2DTB11 [R/W] 00000000 00000000		
00C168 _H - 00C17C _H	reserved				reserved
00C180 _H	TREQR21 [R] 00000000 00000000		TREQR11 [R] 00000000 00000000		CAN 1 Status Flags
00C184 _H	TREQR41 [R] 00000000 00000000		TREQR31 [R] 00000000 00000000		
00C188 _H	TREQR61 [R] 00000000 00000000		TREQR51 [R] 00000000 00000000		
00C18C _H	TREQR81 [R] 00000000 00000000		TREQR71 [R] 00000000 00000000		
00C190 _H	NEWDT21 [R] 00000000 00000000		NEWDT11 [R] 00000000 00000000		
00C194 _H	NEWDT41 [R] 00000000 00000000		NEWDT31 [R] 00000000 00000000		
00C198 _H	NEWDT61 [R] 00000000 00000000		NEWDT51 [R] 00000000 00000000		
00C19C _H	NEWDT81 [R] 00000000 00000000		NEWDT71 [R] 00000000 00000000		
00C1A0 _H	INTPND21 [R] 00000000 00000000		INTPND11 [R] 00000000 00000000		
00C1A4 _H	INTPND41 [R] 00000000 00000000		INTPND31 [R] 00000000 00000000		
00C1A8 _H	INTPND61 [R] 00000000 00000000		INTPND51 [R] 00000000 00000000		
00C1AC _H	INTPND81 [R] 00000000 00000000		INTPND71 [R] 00000000 00000000		
00C1B0 _H	MSGVAL21 [R] 00000000 00000000		MSGVAL11 [R] 00000000 00000000		
00C1B4 _H	MSGVAL41 [R] 00000000 00000000		MSGVAL31 [R] 00000000 00000000		
00C1B8 _H	MSGVAL61 [R] 00000000 00000000		MSGVAL51 [R] 00000000 00000000		
00C1BC _H	MSGVAL81 [R] 00000000 00000000		MSGVAL71 [R] 00000000 00000000		

MB91460Q Series

Address	Register				Block
	+0	+1	+2	+3	
00C1C0 _H - 00C4FC _H	reserved				reserved
00C500 _H	CTRLR5 [R/W] 00000000 00000001		STATR5 [R/W] 00000000 00000000		CAN 5 Control Register
00C504 _H	ERRCNT5 [R] 00000000 00000000		BTR5 [R/W] 00100011 00000001		
00C508 _H	INTR5 [R] 00000000 00000000		TESTR5 [R/W] 00000000 X0000000		
00C50C _H	BRPE5 [R/W] 00000000 00000000		reserved		
00C510 _H	IF1CREQ5 [R/W] 00000000 00000001		IF1CMSK5 [R/W] 00000000 00000000		CAN 5 IF 1 Register
00C514 _H	IF1MSK25 [R/W] 11111111 11111111		IF1MSK15 [R/W] 11111111 11111111		
00C518 _H	IF1ARB25 [R/W] 00000000 00000000		IF1ARB15 [R/W] 00000000 00000000		
00C51C _H	IF1MCTR5 [R/W] 00000000 00000000		reserved		
00C520 _H	IF1DTA15 [R/W] 00000000 00000000		IF1DTA25 [R/W] 00000000 00000000		
00C524 _H	IF1DTB15 [R/W] 00000000 00000000		IF1DTB25 [R/W] 00000000 00000000		
00C528 _H - 00C52C _H	reserved				reserved
00C530 _H	IF1DTA25 [R/W] 00000000 00000000		IF1DTA15 [R/W] 00000000 00000000		CAN 5 IF 1 Register mirror
00C534 _H	IF1DTB25 [R/W] 00000000 00000000		IF1DTB15 [R/W] 00000000 00000000		
00C538 _H - 00C53C _H	reserved				reserved

MB91460Q Series

Address	Register				Block
	+0	+1	+2	+3	
00C540 _H	IF2CREQ5 [R/W] 00000000 00000001		IF2CMSK5 [R/W] 00000000 00000000		CAN 5 IF 2 Register
00C544 _H	IF2MSK25 [R/W] 11111111 11111111		IF2MSK15 [R/W] 11111111 11111111		
00C548 _H	IF2ARB25 [R/W] 00000000 00000000		IF2ARB15 [R/W] 00000000 00000000		
00C54C _H	IF2MCTR5 [R/W] 00000000 00000000		reserved		
00C550 _H	IF2DTA15 [R/W] 00000000 00000000		IF2DTA25 [R/W] 00000000 00000000		
00C554 _H	IF2DTB15 [R/W] 00000000 00000000		IF2DTB25 [R/W] 00000000 00000000		
00C558 _H - 00C55C _H	reserved				reserved
00C560 _H	IF2DTA25 [R/W] 00000000 00000000		IF2DTA15 [R/W] 00000000 00000000		CAN 5 IF 2 Register mirror
00C564 _H	IF2DTB25 [R/W] 00000000 00000000		IF2DTB15 [R/W] 00000000 00000000		
00C568 _H - 00C57C _H	reserved				reserved

MB91460Q Series

Address	Register				Block
	+0	+1	+2	+3	
00C580 _H	TREQR25 [R] 00000000 00000000		TREQR15 [R] 00000000 00000000		CAN 5 Status Flags
00C584 _H	TREQR45 [R] 00000000 00000000		TREQR35 [R] 00000000 00000000		
00C588 _H	TREQR65 [R] 00000000 00000000		TREQR55 [R] 00000000 00000000		
00C58C _H	TREQR85 [R] 00000000 00000000		TREQR75 [R] 00000000 00000000		
00C590 _H	NEWDT25 [R] 00000000 00000000		NEWDT15 [R] 00000000 00000000		
00C594 _H	NEWDT45 [R] 00000000 00000000		NEWDT35 [R] 00000000 00000000		
00C598 _H	NEWDT65 [R] 00000000 00000000		NEWDT55 [R] 00000000 00000000		
00C59C _H	NEWDT85 [R] 00000000 00000000		NEWDT75 [R] 00000000 00000000		
00C5A0 _H	INTPND25 [R] 00000000 00000000		INTPND15 [R] 00000000 00000000		
00C5A4 _H	INTPND45 [R] 00000000 00000000		INTPND35 [R] 00000000 00000000		
00C5A8 _H	INTPND65 [R] 00000000 00000000		INTPND55 [R] 00000000 00000000		
00C5AC _H	INTPND85 [R] 00000000 00000000		INTPND75 [R] 00000000 00000000		
00C5B0 _H	MSGVAL25 [R] 00000000 00000000		MSGVAL15 [R] 00000000 00000000		
00C5B4 _H	MSGVAL45 [R] 00000000 00000000		MSGVAL35 [R] 00000000 00000000		
00C5B8 _H	MSGVAL65 [R] 00000000 00000000		MSGVAL55 [R] 00000000 00000000		
00C5BC _H	MSGVAL85 [R] 00000000 00000000		MSGVAL75 [R] 00000000 00000000		
00C5C0 _H - 00EFC _H	reserved				reserved

MB91460Q Series

Address	Register				Block
	+0	+1	+2	+3	
00F00H	BCTRL [R/W] ----- 11111100 00000000				EDSU / MPU Control + IRQ
00F004H	BSTAT [R/W] ----- 000 00000000 10 -- 0000				
00F008H	BIAC [R] ----- 00000000 00000000				
00F00CH	BOAC [R] ----- 00000000 00000000				
00F010H	BIRQ [R/W] ----- 00000000 00000000				
00F014H - 00F01CH	reserved				reserved
00F020H	BCR0 [R/W] ----- 00000000 00000000 00000000				EDSU / MPU Control
00F024H	BCR1 [R/W] ----- 00000000 00000000 00000000				
00F028H	BCR2 [R/W] ----- 00000000 00000000 00000000				
00F02CH	BCR3 [R/W] ----- 00000000 00000000 00000000				
00F030H - 00F07CH	reserved				reserved
00F080H	BAD0 [R/W] XXXXXXXX XXXXXXXX XXXXXXXX XXXXXXXX				EDSU / MPU ch. 0
00F084H	BAD1 [R/W] XXXXXXXX XXXXXXXX XXXXXXXX XXXXXXXX				
00F088H	BAD2 [R/W] XXXXXXXX XXXXXXXX XXXXXXXX XXXXXXXX				
00F08CH	BAD3 [R/W] XXXXXXXX XXXXXXXX XXXXXXXX XXXXXXXX				
00F090H	BAD4 [R/W] XXXXXXXX XXXXXXXX XXXXXXXX XXXXXXXX				EDSU / MPU ch. 1
00F094H	BAD5 [R/W] XXXXXXXX XXXXXXXX XXXXXXXX XXXXXXXX				
00F098H	BAD6 [R/W] XXXXXXXX XXXXXXXX XXXXXXXX XXXXXXXX				
00F09CH	BAD7 [R/W] XXXXXXXX XXXXXXXX XXXXXXXX XXXXXXXX				

MB91460Q Series

Address	Register				Block
	+0	+1	+2	+3	
00F0A0 _H	BAD8 [R/W] XXXXXXXX XXXXXXXX XXXXXXXX XXXXXXXX				EDSU / MPU ch. 2
00F0A4 _H	BAD9 [R/W] XXXXXXXX XXXXXXXX XXXXXXXX XXXXXXXX				
00F0A8 _H	BAD10 [R/W] XXXXXXXX XXXXXXXX XXXXXXXX XXXXXXXX				
00F0AC _H	BAD11 [R/W] XXXXXXXX XXXXXXXX XXXXXXXX XXXXXXXX				
00F0B0 _H	BAD12 [R/W] XXXXXXXX XXXXXXXX XXXXXXXX XXXXXXXX				EDSU / MPU ch. 3
00F0B4 _H	BAD13 [R/W] XXXXXXXX XXXXXXXX XXXXXXXX XXXXXXXX				
00F0B8 _H	BAD14 [R/W] XXXXXXXX XXXXXXXX XXXXXXXX XXXXXXXX				
00F0BC _H	BAD15 [R/W] XXXXXXXX XXXXXXXX XXXXXXXX XXXXXXXX				
00F0C0 _H - 00FFFC _H	reserved				reserved
010000 _H - 013FFC _H	Cache TAG way 1 (010000 _H - 0107FC _H)				2 Way Set Asso- ciative I-Cache 4 KB
014000 _H - 017FFC _H	Cache TAG way 2 (014000 _H - 0147FC _H)				
018000 _H - 01BFFC _H	Cache RAM way 1 (018000 _H - 0187FC _H)				
01C000 _H - 01FFFC _H	Cache RAM way 2 01C000 _H - 01C7FC _H)				
020000 _H - 02FFFC _H	MB91F469QA D-RAM size is 64 KB (data access is 0 waitcycles)				Data-RAM
030000 _H - 037FFC _H	MB91F469QA I-/D-RAM size is 32 KB (instruction access is 0 waitcycles, data access is 1 waitcycle)				Instruction/ Data RAM
380000 _H - 03FFFC _H	reserved				reserved

1. depends on the number of available CAN channels
2. ACRO[11:10] depends on bus width setting in Mode vector fetch information
3. TCR[3:0] INIT value = 0000, keeps value after RST
4. Always write 1 to IOS[1] !

MB91460Q Series

5. External Bus PFR registers are initial 0x00 in internal vector fetch mode (MD=000) and 0xff otherwise.

2. Flash memory and external bus area

32bit read/write	dat[31:0]				dat[31:0]				Block
16bit read/write	dat[31:16]		dat[15:0]		dat[31:16]		dat[15:0]		
Address	+ 0	+ 1	+ 2	+ 3	+ 4	+ 5	+ 6	+ 7	
040000 _H to 05FFFF _H	SA8 (64kB)				SA9 (64kB)				ROMS0
060000 _H to 07FFFF _H	SA10 (64kB)				SA11 (64kB)				ROMS1
080000 _H to 09FFFF _H	SA12 (64kB)				SA13 (64kB)				ROMS2
0A0000 _H to 0BFFFF _H	SA14 (64kB)				SA15 (64kB)				ROMS3
0C0000 _H to 0DFFFF _H	SA16 (64kB)				SA17 (64kB)				ROMS4
0E0000 _H to 0FFFF0 _H	SA18 (64kB)				SA19 (64kB)				ROMS5
0FFFF8 _H	FMV [R] 06 00 00 00 _H				FRV [R] 00 00 BF F8 _H				
100000 _H to 11FFFF _H	SA20 (64kB)				SA21 (64kB)				ROMS6
120000 _H to 13FFFF _H	SA22 (64kB)				SA23 (64kB)				
140000 _H to 15FFFF _H	SA24 (64kB)				SA25 (64kB)				ROMS7
160000 _H to 17FFFF _H	SA26 (64kB)				SA27 (64kB)				
180000 _H to 19FFFF _H	SA28 (64kB)				SA29 (64kB)				ROMS8
1A0000 _H to 1BFFFF _H	SA30 (64kB)				SA31 (64kB)				

MB91460Q Series

32bit read/write	dat[31:0]				dat[31:0]				Block
16bit read/write	dat[31:16]		dat[15:0]		dat[31:16]		dat[15:0]		
Address	+ 0	+ 1	+ 2	+ 3	+ 4	+ 5	+ 6	+ 7	
1C0000 _H to 1DFFFF _H	SA32 (64kB)				SA33 (64kB)				ROMS9
1E0000 _H to 1FFFFF _H	SA34 (64kB)				SA35 (64kB)				
200000 _H to 21FFFF _H	SA36 (64kB)				SA37 (64kB)				ROMS10
220000 _H to 23FFFF _H	SA38 (64kB)				SA39 (64kB)				
240000 _H to 243FFF _H	SA0 (8kB)				SA1 (8kB)				
244000 _H to 247FFF _H	SA2 (8kB)				SA3 (8kB)				
248000 _H to 24BFFF _H	SA4 (8kB)				SA5 (8kB)				
24C000 _H to 24FFFF _H	SA6 (8kB)				SA7 (8kB)				
250000 _H to 27FFFF _H	reserved								
280000 _H to 2FFFF8 _H	External Bus Area								ROMS11
300000 _H to 37FFF8 _H									ROMS12
380000 _H to 3FFFF8 _H									ROMS13
400000 _H to 47FFF8 _H									ROMS14
480000 _H to 4FFFF8 _H									ROMS15

Note: Write operations to address 0FFFF8_H and 0FFFFC_H are not possible. When reading these addresses, the values shown above will be read.

■ INTERRUPT VECTOR TABLE

Interrupt	Interrupt number		Interrupt level *1		Interrupt vector *2		DMA Resource number
	Decimal	Hexadecimal	Setting Register	Register address	Offset	Default Vector address	
Reset	0	00	—	—	3FC _H	000FFFFC _H	—
Mode vector	1	01	—	—	3F8 _H	000FFFF8 _H	—
System reserved	2	02	—	—	3F4 _H	000FFFF4 _H	—
System reserved	3	03	—	—	3F0 _H	000FFFF0 _H	—
System reserved	4	04	—	—	3EC _H	000FFFE _C	—
CPU supervisor mode (INT #5 instruction) *5	5	05	—	—	3E8 _H	000FFFE8 _H	—
Memory Protection exception *5	6	06	—	—	3E4 _H	000FFFE4 _H	—
System reserved	7	07	—	—	3E0 _H	000FFFE0 _H	—
System reserved	8	08	—	—	3DC _H	000FFFD _C	—
System reserved	9	09	—	—	3D8 _H	000FFFD8 _H	—
System reserved	10	0A	—	—	3D4 _H	000FFFD4 _H	—
System reserved	11	0B	—	—	3D0 _H	000FFFD0 _H	—
System reserved	12	0C	—	—	3CC _H	000FFFC _C	—
System reserved	13	0D	—	—	3C8 _H	000FFFC8 _H	—
Undefined instruction exception	14	0E	—	—	3C4 _H	000FFFC4 _H	—
NMI request	15	0F	F _H fixed		3C0 _H	000FFFC0 _H	—
External Interrupt 0 External Interrupt 16	16	10	ICR00	440 _H	3BC _H	000FFFB _C	0, 16 136
External Interrupt 1 External Interrupt 17	17	11			3B8 _H	000FFFB8 _H	1, 17 137
External Interrupt 2 External Interrupt 18	18	12	ICR01	441 _H	3B4 _H	000FFFB4 _H	2, 18 138
External Interrupt 3 External Interrupt 19	19	13			3B0 _H	000FFFB0 _H	3, 19 139
External Interrupt 4 External Interrupt 20	20	14	ICR02	442 _H	3AC _H	000FFFA _C	20 140
External Interrupt 5 External Interrupt 21	21	15			3A8 _H	000FFFA8 _H	21 141
External Interrupt 6 External Interrupt 22	22	16	ICR03	443 _H	3A4 _H	000FFFA4 _H	22 142
External Interrupt 7 External Interrupt 23	23	17			3A0 _H	000FFFA0 _H	23 143
External Interrupt 8 External Interrupt 24	24	18	ICR04	444 _H	39C _H	000FFF9 _C	—
External Interrupt 9 External Interrupt 25	25	19			398 _H	000FFF98 _H	—

MB91460Q Series

Interrupt	Interrupt number		Interrupt level *1		Interrupt vector *2		DMA Resource number
	Decimal	Hexadecimal	Setting Register	Register address	Offset	Default Vector address	
External Interrupt 10 External Interrupt 26	26	1A	ICR05	445 _H	394 _H	000FFF94 _H	—
External Interrupt 11 External Interrupt 27	27	1B			390 _H	000FFF90 _H	—
External Interrupt 12 External Interrupt 28	28	1C	ICR06	446 _H	38C _H	000FFF8C _H	—
External Interrupt 13 External Interrupt 29	29	1D			388 _H	000FFF88 _H	—
External Interrupt 14 External Interrupt 30	30	1E	ICR07	447 _H	384 _H	000FFF84 _H	—
External Interrupt 15 External Interrupt 31	31	1F			380 _H	000FFF80 _H	—
Reload Timer 0	32	20	ICR08	448 _H	37C _H	000FFF7C _H	4, 32
Reload Timer 1	33	21			378 _H	000FFF78 _H	5, 33
Reload Timer 2	34	22	ICR09	449 _H	374 _H	000FFF74 _H	34
Reload Timer 3	35	23			370 _H	000FFF70 _H	35
Reload Timer 4	36	24	ICR10	44A _H	36C _H	000FFF6C _H	36
Reload Timer 5	37	25			368 _H	000FFF68 _H	37
Reload Timer 6	38	26	ICR11	44B _H	364 _H	000FFF64 _H	38
Reload Timer 7	39	27			360 _H	000FFF60 _H	39
Free Run Timer 0 Free Run Timer 8	40	28	ICR12	44C _H	35C _H	000FFF5C _H	40 176
Free Run Timer 1	41	29			358 _H	000FFF58 _H	41
Free Run Timer 2	42	2A	ICR13	44D _H	354 _H	000FFF54 _H	42
Free Run Timer 3	43	2B			350 _H	000FFF50 _H	43
Free Run Timer 4	44	2C	ICR14	44E _H	34C _H	000FFF4C _H	44
Free Run Timer 5	45	2D			348 _H	000FFF48 _H	45
Free Run Timer 6	46	2E	ICR15	44F _H	344 _H	000FFF44 _H	46
Free Run Timer 7	47	2F			340 _H	000FFF40 _H	47
CAN 0	48	30	ICR16	450 _H	33C _H	000FFF3C _H	—
CAN 1	49	31			338 _H	000FFF38 _H	—
reserved	50	32	ICR17	451 _H	334 _H	000FFF34 _H	—
reserved	51	33			330 _H	000FFF30 _H	—
reserved	52	34	ICR18	452 _H	32C _H	000FFF2C _H	—
CAN 5	53	35			328 _H	000FFF28 _H	—
LIN-USART 0 RX	54	36	ICR19	453 _H	324 _H	000FFF24 _H	6, 48
LIN-USART 0 TX	55	37			320 _H	000FFF20 _H	7, 49

MB91460Q Series

Interrupt	Interrupt number		Interrupt level *1		Interrupt vector *2		DMA Resource number
	Decimal	Hexadecimal	Setting Register	Register address	Offset	Default Vector address	
LIN-USART 1 RX	56	38	ICR20	454 _H	31C _H	000FFF1C _H	8, 50
LIN-USART 1 TX	57	39			318 _H	000FFF18 _H	9, 51
LIN-USART 2 RX	58	3A	ICR21	455 _H	314 _H	000FFF14 _H	52
LIN-USART 2 TX	59	3B			310 _H	000FFF10 _H	53
LIN-USART 3 RX	60	3C	ICR22	456 _H	30C _H	000FFF0C _H	54
LIN-USART 3 TX	61	3D			308 _H	000FFF08 _H	55
System reserved	62	3E	ICR23 *3	457 _H	304 _H	000FFF04 _H	—
Delayed Interrupt	63	3F			300 _H	000FFF00 _H	—
System reserved *4	64	40	(ICR24)	(458 _H)	2FC _H	000FFEFC _H	—
System reserved *4	65	41			2F8 _H	000FFE8 _H	—
LIN-USART (FIFO) 4 RX	66	42	ICR25	459 _H	2F4 _H	000FFE4 _H	10, 56
LIN-USART (FIFO) 4 TX	67	43			2F0 _H	000FFE0 _H	11, 57
LIN-USART (FIFO) 5 RX	68	44	ICR26	45A _H	2EC _H	000FEEC _H	12, 58
LIN-USART (FIFO) 5 TX	69	45			2E8 _H	000FEE8 _H	13, 59
LIN-USART (FIFO) 6 RX	70	46	ICR27	45B _H	2E4 _H	000FEE4 _H	60
LIN-USART (FIFO) 6 TX	71	47			2E0 _H	000FEE0 _H	61
LIN-USART (FIFO) 7 RX	72	48	ICR28	45C _H	2DC _H	000FFEDC _H	62
LIN-USART (FIFO) 7 TX	73	49			2D8 _H	000FFED8 _H	63
I2C 2	74	4A	ICR29	45D _H	2D4 _H	000FFED4 _H	—
I2C 1 / I2C 3	75	4B			2D0 _H	000FFED0 _H	—
LIN-USART (FIFO) 8 RX	76	4C	ICR30	45E _H	2CC _H	000FFEC _H	64
LIN-USART (FIFO) 8 TX	77	4D			2C8 _H	000FFEC8 _H	65
LIN-USART (FIFO) 9 RX	78	4E	ICR31	45F _H	2C4 _H	000FFEC4 _H	66
LIN-USART (FIFO) 9 TX	79	4F			2C0 _H	000FFEC0 _H	67
LIN-USART (FIFO) 10 RX	80	50	ICR32	460 _H	2BC _H	000FFEB _H	68
LIN-USART (FIFO) 10 TX	81	51			2B8 _H	000FFEB8 _H	69
LIN-USART (FIFO) 11 RX	82	52	ICR33	461 _H	2B4 _H	000FFEB4 _H	70
LIN-USART (FIFO) 11 TX	83	53			2B0 _H	000FFEB0 _H	71
System reserved	84	54	ICR34	462 _H	2AC _H	000FFEAC _H	72
System reserved	85	55			2A8 _H	000FFE8 _H	73
System reserved	86	56	ICR35	463 _H	2A4 _H	000FFEA4 _H	74
System reserved	87	57			2A0 _H	000FFEA0 _H	75
System reserved	88	58	ICR36	464 _H	29C _H	000FFE9C _H	76
System reserved	89	59			298 _H	000FFE98 _H	77

MB91460Q Series

Interrupt	Interrupt number		Interrupt level *1		Interrupt vector *2		DMA Resource number
	Decimal	Hexadecimal	Setting Register	Register address	Offset	Default Vector address	
System reserved	90	5A	ICR37	465 _H	294 _H	000FFE94 _H	78
System reserved	91	5B			290 _H	000FFE90 _H	79
Input Capture 0 Input Capture 8	92	5C	ICR38	466 _H	28C _H	000FFE8C _H	80 180
Input Capture 1 Input Capture 9	93	5D			288 _H	000FFE88 _H	81 181
Input Capture 2	94	5E	ICR39	467 _H	284 _H	000FFE84 _H	82
Input Capture 3	95	5F			280 _H	000FFE80 _H	83
Input Capture 4	96	60	ICR40	468 _H	27C _H	000FFE7C _H	84
Input Capture 5	97	61			278 _H	000FFE78 _H	85
Input Capture 6	98	62	ICR41	469 _H	274 _H	000FFE74 _H	86
Input Capture 7	99	63			270 _H	000FFE70 _H	87
Output Compare 0	100	64	ICR42	46A _H	26C _H	000FFE6C _H	88
Output Compare 1	101	65			268 _H	000FFE68 _H	89
Output Compare 2	102	66	ICR43	46B _H	264 _H	000FFE64 _H	90
Output Compare 3	103	67			260 _H	000FFE60 _H	91
Output Compare 4	104	68	ICR44	46C _H	25C _H	000FFE5C _H	92
Output Compare 5	105	69			258 _H	000FFE58 _H	93
Output Compare 6	106	6A	ICR45	46D _H	254 _H	000FFE54 _H	94
Output Compare 7	107	6B			250 _H	000FFE50 _H	95
Sound Generator	108	6C	ICR46	46E _H	24C _H	000FFE4C _H	—
Phase Frequency Modulator	109	6D			248 _H	000FFE48 _H	—
System reserved	110	6E	ICR47 *3	46F _H	244 _H	000FFE44 _H	—
System reserved	111	6F			240 _H	000FFE40 _H	—
PPG0	112	70	ICR48	470 _H	23C _H	000FFE3C _H	15, 96
PPG1	113	71			238 _H	000FFE38 _H	97
PPG2	114	72	ICR49	471 _H	234 _H	000FFE34 _H	98
PPG3	115	73			230 _H	000FFE30 _H	99
PPG4	116	74	ICR50	472 _H	22C _H	000FFE2C _H	100
PPG5	117	75			228 _H	000FFE28 _H	101
PPG6	118	76	ICR51	473 _H	224 _H	000FFE24 _H	102
PPG7	119	77			220 _H	000FFE20 _H	103
PPG8	120	78	ICR52	474 _H	21C _H	000FFE1C _H	104
PPG9	121	79			218 _H	000FFE18 _H	105

MB91460Q Series

Interrupt	Interrupt number		Interrupt level *1		Interrupt vector *2		DMA Resource number
	Decimal	Hexadecimal	Setting Register	Register address	Offset	Default Vector address	
PPG10	122	7A	ICR53	475 _H	214 _H	000FFE14 _H	106
PPG11	123	7B			210 _H	000FFE10 _H	107
PPG12	124	7C	ICR54	476 _H	20C _H	000FFE0C _H	108
PPG13	125	7D			208 _H	000FFE08 _H	109
PPG14	126	7E	ICR55	477 _H	204 _H	000FFE04 _H	110
PPG15	127	7F			200 _H	000FFE00 _H	111
Up/Down Counter 0	128	80	ICR56	478 _H	1FC _H	000FFDFC _H	—
Up/Down Counter 1	129	81			1F8 _H	000FFDF8 _H	—
Up/Down Counter 2	130	82	ICR57	479 _H	1F4 _H	000FFDF4 _H	—
Up/Down Counter 3	131	83			1F0 _H	000FFDF0 _H	—
Real Time Clock	132	84	ICR58	47A _H	1EC _H	000FFDEC _H	—
Calibration Unit	133	85			1E8 _H	000FFDE8 _H	—
A/D Converter 0	134	86	ICR59	47B _H	1E4 _H	000FFDE4 _H	14, 112
A/D Converter 1	135	87			1E0 _H	000FFDE0 _H	113
Alarm Comparator 0	136	88	ICR60	47C _H	1DC _H	000FFDDC _H	—
Alarm Comparator 1	137	89			1D8 _H	000FFDD8 _H	—
Low Voltage Detection	138	8A	ICR61	47D _H	1D4 _H	000FFDD4 _H	—
System reserved	139	8B			1D0 _H	000FFDD0 _H	—
Timebase Overflow	140	8C	ICR62	47E _H	1CC _H	000FFDCC _H	—
PLL Clock Gear	141	8D			1C8 _H	000FFDC8 _H	—
DMA Controller	142	8E	ICR63	47F _H	1C4 _H	000FFDC4 _H	—
Main/Sub OSC stability wait	143	8F			1C0 _H	000FFDC0 _H	—
Security vector	144	90	—	—	1BC _H	000FFDBC _H	—
Used by the INT instruction.	145 to 255	91 to FF	—	—	1B8 _H to 000 _H	000FFDB8 _H to 000FFC00 _H	—

*1 : The Interrupt Control Registers (ICRs) are located in the interrupt controller and set the interrupt level for each interrupt request. An ICR is provided for each interrupt request.

*2 : The vector address for each EIT (exception, interrupt or trap) is calculated by adding the listed offset to the table base register value (TBR) . The TBR specifies the top of the EIT vector table. The addresses listed in the table are for the default TBR value (000FFC00_H) . The TBR is initialized to this value by a reset. The TBR is set to 000FFC00_H after the internal boot ROM is executed.

*3 : ICR23 and ICR47 can be exchanged by setting the REALOS compatibility bit (addr 0C03_H : IOS[0])

*4 : Used by REALOS

*5 : Memory Protection Unit (MPU) support

MB91460Q Series

■ RECOMMENDED SETTINGS

1. PLL and Clockgear settings

Please note that for MB91F469QA core base clock frequencies above 88MHz can only be achieved with 1.9V core supply voltage *1.

Please refer to [Absolute maximum ratings on page 101](#) to find the maximum allowed frequency of Core Base Clock (fCLKB) at high temperature.

Recommended PLL divider and clockgear settings

PLL Input (CLK) [MHz]	Frequency Parameter		Clockgear Parameter		PLL Output (X) [MHz]	Core Base Clock [MHz]	1.8V	1.9V
	DIVM	DIVN	DIVG	MULG				
4	2	25	16	24	200	100	no	yes
4	2	24	16	24	192	96	no	yes
4	2	23	16	24	184	92	no	yes
4	2	22	16	24	176	88	yes	yes
4	2	21	16	20	168	84	yes	yes
4	2	20	16	20	160	80	yes	yes
4	2	19	16	20	152	76	yes	yes
4	2	18	16	20	144	72	yes	yes
4	2	17	16	16	136	68	yes	yes
4	2	16	16	16	128	64	yes	yes
4	2	15	16	16	120	60	yes	yes
4	2	14	16	16	112	56	yes	yes
4	2	13	16	12	104	52	yes	yes
4	2	12	16	12	96	48	yes	yes
4	2	11	16	12	88	44	yes	yes
4	4	10	16	24	160	40	yes	yes
4	4	9	16	24	144	36	yes	yes
4	4	8	16	24	128	32	yes	yes
4	4	7	16	24	112	28	yes	yes
4	6	6	16	24	144	24	yes	yes
4	8	5	16	28	160	20	yes	yes
4	10	4	16	32	160	16	yes	yes
4	12	3	16	32	144	12	yes	yes

*1: In order to enter this mode please set REGSEL_FLASHSEL=1 and REGSEL_MAINSEL=1 (HWM Chapter 52.3.1)

2. Clock Modulator settings

The following table shows all possible settings for the Clock Modulator in a base clock frequency range from 32MHz up to 88MHz.

If Fmax exceeds 88MHz the core supply voltage needs to be set to 1.9V. Please refer to flash access time settings (section 2.3.2.2) to setup the correct voltage according to Fmax in the table below.

The Flash access time settings need to be adjusted according to Fmax while the PLL and clockgear settings should be set according to base clock frequency.

Please refer to [Absolute maximum ratings on page 101](#) to find the maximum allowed frequency of Fmax (fCLKB) at high temperature.

Clock Modulator settings, frequency range and supported supply voltage

Modulation Degree (k)	Random No (N)	CMPR [hex]	Baseclk [MHz]	Fmin [MHz]	Fmax [MHz]	Remarks
1	3	026F	88	79.5	98.5	
1	3	026F	84	76.1	93.8	
1	3	026F	80	72.6	89.1	
1	5	02AE	80	68.7	95.8	
2	3	046E	80	68.7	95.8	
1	3	026F	76	69.1	84.5	
1	5	02AE	76	65.3	90.8	
1	7	02ED	76	62	98.1	
2	3	046E	76	65.3	90.8	
3	3	066D	76	62	98.1	
1	3	026F	72	65.5	79.9	
1	5	02AE	72	62	85.8	
1	7	02ED	72	58.8	92.7	
2	3	046E	72	62	85.8	
3	3	066D	72	58.8	92.7	
1	3	026F	68	62	75.3	
1	5	02AE	68	58.7	80.9	
1	7	02ED	68	55.7	87.3	
1	9	032C	68	53	95	
2	3	046E	68	58.7	80.9	
2	5	04AC	68	53	95	
3	3	066D	68	55.7	87.3	
4	3	086C	68	53	95	
1	3	026F	64	58.5	70.7	
1	5	02AE	64	55.3	75.9	
1	7	02ED	64	52.5	82	
1	9	032C	64	49.9	89.1	
1	11	036B	64	47.6	97.6	

MB91460Q Series

(Continued)

Modulation Degree (k)	Random No (N)	CMPR [hex]	Baseclk [MHz]	Fmin [MHz]	Fmax [MHz]	Remarks
2	3	046E	64	55.3	75.9	
2	5	04AC	64	49.9	89.1	
3	3	066D	64	52.5	82	
4	3	086C	64	49.9	89.1	
5	3	0A6B	64	47.6	97.6	
1	3	026F	60	54.9	66.1	
1	5	02AE	60	51.9	71	
1	7	02ED	60	49.3	76.7	
1	9	032C	60	46.9	83.3	
1	11	036B	60	44.7	91.3	
2	3	046E	60	51.9	71	
2	5	04AC	60	46.9	83.3	
3	3	066D	60	49.3	76.7	
4	3	086C	60	46.9	83.3	
5	3	0A6B	60	44.7	91.3	
1	3	026F	56	51.4	61.6	
1	5	02AE	56	48.6	66.1	
1	7	02ED	56	46.1	71.4	
1	9	032C	56	43.8	77.6	
1	11	036B	56	41.8	84.9	
1	13	03AA	56	39.9	93.8	
2	3	046E	56	48.6	66.1	
2	5	04AC	56	43.8	77.6	
2	7	04EA	56	39.9	93.8	
3	3	066D	56	46.1	71.4	
3	5	06AA	56	39.9	93.8	
4	3	086C	56	43.8	77.6	
5	3	0A6B	56	41.8	84.9	
6	3	0C6A	56	39.9	93.8	
1	3	026F	52	47.8	57	
1	5	02AE	52	45.2	61.2	
1	7	02ED	52	42.9	66.1	
1	9	032C	52	40.8	71.8	
1	11	036B	52	38.8	78.6	
1	13	03AA	52	37.1	86.8	

(Continued)

MB91460Q Series

(Continued)

Modulation Degree (k)	Random No (N)	CMPR [hex]	Baseclk [MHz]	Fmin [MHz]	Fmax [MHz]	Remarks
1	15	03E9	52	35.5	96.9	
2	3	046E	52	45.2	61.2	
2	5	04AC	52	40.8	71.8	
2	7	04EA	52	37.1	86.8	
3	3	066D	52	42.9	66.1	
3	5	06AA	52	37.1	86.8	
4	3	086C	52	40.8	71.8	
5	3	0A6B	52	38.8	78.6	
6	3	0C6A	52	37.1	86.8	
7	3	0E69	52	35.5	96.9	
1	3	026F	48	44.2	52.5	
1	5	02AE	48	41.8	56.4	
1	7	02ED	48	39.6	60.9	
1	9	032C	48	37.7	66.1	
1	11	036B	48	35.9	72.3	
1	13	03AA	48	34.3	79.9	
1	15	03E9	48	32.8	89.1	
2	3	046E	48	41.8	56.4	
2	5	04AC	48	37.7	66.1	
2	7	04EA	48	34.3	79.9	
3	3	066D	48	39.6	60.9	
3	5	06AA	48	34.3	79.9	
4	3	086C	48	37.7	66.1	
5	3	0A6B	48	35.9	72.3	
6	3	0C6A	48	34.3	79.9	
7	3	0E69	48	32.8	89.1	
1	3	026F	44	40.6	48.1	
1	5	02AE	44	38.4	51.6	
1	7	02ED	44	36.4	55.7	
1	9	032C	44	34.6	60.4	
1	11	036B	44	33	66.1	
1	13	03AA	44	31.5	73	
1	15	03E9	44	30.1	81.4	
2	3	046E	44	38.4	51.6	
2	5	04AC	44	34.6	60.4	

(Continued)

MB91460Q Series

(Continued)

Modulation Degree (k)	Random No (N)	CMPR [hex]	Baseclk [MHz]	Fmin [MHz]	Fmax [MHz]	Remarks
2	7	04EA	44	31.5	73	
2	9	0528	44	28.9	92.1	
3	3	066D	44	36.4	55.7	
3	5	06AA	44	31.5	73	
4	3	086C	44	34.6	60.4	
4	5	08A8	44	28.9	92.1	
5	3	0A6B	44	33	66.1	
6	3	0C6A	44	31.5	73	
7	3	0E69	44	30.1	81.4	
8	3	1068	44	28.9	92.1	
1	3	026F	40	37	43.6	
1	5	02AE	40	34.9	46.8	
1	7	02ED	40	33.1	50.5	
1	9	032C	40	31.5	54.8	
1	11	036B	40	30	59.9	
1	13	03AA	40	28.7	66.1	
1	15	03E9	40	27.4	73.7	
2	3	046E	40	34.9	46.8	
2	5	04AC	40	31.5	54.8	
2	7	04EA	40	28.7	66.1	
2	9	0528	40	26.3	83.3	
3	3	066D	40	33.1	50.5	
3	5	06AA	40	28.7	66.1	
3	7	06E7	40	25.3	95.8	
4	3	086C	40	31.5	54.8	
4	5	08A8	40	26.3	83.3	
5	3	0A6B	40	30	59.9	
6	3	0C6A	40	28.7	66.1	
7	3	0E69	40	27.4	73.7	
8	3	1068	40	26.3	83.3	
9	3	1267	40	25.3	95.8	
1	3	026F	36	33.3	39.2	
1	5	02AE	36	31.5	42	
1	7	02ED	36	29.9	45.3	
1	9	032C	36	28.4	49.2	

(Continued)

MB91460Q Series

(Continued)

Modulation Degree (k)	Random No (N)	CMPR [hex]	Baseclk [MHz]	Fmin [MHz]	Fmax [MHz]	Remarks
1	11	036B	36	27.1	53.8	
1	13	03AA	36	25.8	59.3	
1	15	03E9	36	24.7	66.1	
2	3	046E	36	31.5	42	
2	5	04AC	36	28.4	49.2	
2	7	04EA	36	25.8	59.3	
2	9	0528	36	23.7	74.7	
3	3	066D	36	29.9	45.3	
3	5	06AA	36	25.8	59.3	
3	7	06E7	36	22.8	85.8	
4	3	086C	36	28.4	49.2	
4	5	08A8	36	23.7	74.7	
5	3	0A6B	36	27.1	53.8	
6	3	0C6A	36	25.8	59.3	
7	3	0E69	36	24.7	66.1	
8	3	1068	36	23.7	74.7	
9	3	1267	36	22.8	85.8	
1	3	026F	32	29.7	34.7	
1	5	02AE	32	28	37.3	
1	7	02ED	32	26.6	40.2	
1	9	032C	32	25.3	43.6	
1	11	036B	32	24.1	47.7	
1	13	03AA	32	23	52.5	
1	15	03E9	32	22	58.6	
2	3	046E	32	28	37.3	
2	5	04AC	32	25.3	43.6	
2	7	04EA	32	23	52.5	
2	9	0528	32	21.1	66.1	
2	11	0566	32	19.5	89.1	
3	3	066D	32	26.6	40.2	
3	5	06AA	32	23	52.5	
3	7	06E7	32	20.3	75.9	
4	3	086C	32	25.3	43.6	
4	5	08A8	32	21.1	66.1	
5	3	0A6B	32	24.1	47.7	

(Continued)

MB91460Q Series

(Continued)

Modulation Degree (k)	Random No (N)	CMPR [hex]	Baseclk [MHz]	Fmin [MHz]	Fmax [MHz]	Remarks
5	5	0AA6	32	19.5	89.1	
6	3	0C6A	32	23	52.5	
7	3	0E69	32	22	58.6	
8	3	1068	32	21.1	66.1	
9	3	1267	32	20.3	75.9	
10	3	1466	32	19.5	89.1	

■ ELECTRICAL CHARACTERISTICS

1. Absolute maximum ratings

Parameter	Symbol	Rating		Unit	Remarks
		Min	Max		
Power supply slew rate	—	—	50	V/ms	
Power supply voltage 1*1	V _{DD5R}	- 0.3	+ 6.0	V	
Power supply voltage 2*1	V _{DD5}	- 0.3	+ 6.0	V	
Power supply voltage 4*1	V _{DD35}	- 0.3	+ 6.0	V	
Relationship of the supply voltages	AV _{CC5}	V _{DD5} -0.3	V _{DD5} +0.3	V	At least one pin of the Ports 25 to 29 (ANn) is used as digital input or output
		V _{SS5} -0.3	V _{DD5} +0.3	V	All pins of the Ports 25 to 29 (ANn) follow the condition of V _{IA}
Analog power supply voltage*1	AV _{CC5}	- 0.3	+ 6.0	V	*2
Analog reference power supply voltage*1	AV _{RH}	- 0.3	+ 6.0	V	*2
Input voltage 1*1	V _{I1}	V _{SS5} - 0.3	V _{DD5} + 0.3	V	
Input voltage 2*1	V _{I2}	V _{SS5} - 0.3	V _{DD35} + 0.3	V	External bus
Analog pin input voltage*1	V _{IA}	AV _{SS5} - 0.3	AV _{CC5} + 0.3	V	
Output voltage 1*1	V _{O1}	V _{SS5} - 0.3	V _{DD5} + 0.3	V	
Output voltage 2*1	V _{O2}	V _{SS5} - 0.3	V _{DD35} + 0.3	V	External bus
Maximum clamp current	I _{CLAMP}	- 4.0	+ 4.0	mA	*3
Total maximum clamp current	∑ I _{CLAMP}	—	20	mA	*3
“L” level maximum output current*4	I _{OL}	—	10	mA	
“L” level average output current*5	I _{OLAV}	—	8	mA	
“L” level total maximum output current	∑I _{OL}	—	100	mA	
“L” level total average output current*6	∑I _{OLAV}	—	50	mA	
“H” level maximum output current*4	I _{OH}	—	- 10	mA	
“H” level average output current*5	I _{OHAV}	—	- 4	mA	
“H” level total maximum output current	∑I _{OH}	—	- 100	mA	
“H” level total average output current*6	∑I _{OHAV}	—	- 25	mA	

MB91460Q Series

Parameter	Symbol	Rating		Unit	Remarks
		Min	Max		
Permitted operating frequency MB91F469QA, MB91F469QAH	$f_{\max, \text{CLKB}}$	—	100	MHz	$T_A \leq 105^\circ\text{C}$, main regulator set to 1.9V
	$f_{\max, \text{CLKP}}$	—	50		
	$f_{\max, \text{CLKT}}$	—	50		
	$f_{\max, \text{CLKCAN}}$	—	50		
Permitted operating frequency MB91F469QAH	$f_{\max, \text{CLKB}}$	—	96	MHz	$T_A \leq 125^\circ\text{C}$, main regulator set to 1.9V
	$f_{\max, \text{CLKP}}$	—	48		
	$f_{\max, \text{CLKT}}$	—	48		
	$f_{\max, \text{CLKCAN}}$	—	48		
Permitted operating frequency MB91F469QA, MB91F469QAH	$f_{\max, \text{CLKB}}$	—	88	MHz	$T_A \leq 105^\circ\text{C}$, main regulator set to 1.8V
	$f_{\max, \text{CLKP}}$	—	44		
	$f_{\max, \text{CLKT}}$	—	44		
	$f_{\max, \text{CLKCAN}}$	—	44		
Permitted operating frequency MB91F469QAH	$f_{\max, \text{CLKB}}$	—	84	MHz	$T_A \leq 125^\circ\text{C}$, main regulator set to 1.8V
	$f_{\max, \text{CLKP}}$	—	42		
	$f_{\max, \text{CLKT}}$	—	42		
	$f_{\max, \text{CLKCAN}}$	—	42		
Permitted power consumption ^{*7}	P_D	—	2000 ^{*8}	mW	$T_A \leq 85^\circ\text{C}$
		—	1300 ^{*8}		$T_A \leq 105^\circ\text{C}$
		—	800 ^{*8}		$T_A \leq 115^\circ\text{C}$
		—	2000 ^{*8}		$T_A \leq 105^\circ\text{C}$, no Flash program/erase ^{*9 *10}
		—	1800 ^{*8}		$T_A \leq 115^\circ\text{C}$, no Flash program/erase ^{*9 *10}
		—	1300 ^{*8}		$T_A \leq 125^\circ\text{C}$, no Flash program/erase ^{*9 *10}
Operating temperature	T_A	- 40	$T_{A(\max)}$	$^\circ\text{C}$	For $T_{A(\max)}$, refer to the ordering information
Storage temperature	T_{stg}	- 55	+ 150	$^\circ\text{C}$	

*1 : The parameter is based on $V_{\text{ss}5} = AV_{\text{ss}5} = 0.0 \text{ V}$.

*2 : $AV_{\text{cc}5}$ and $AVRH5$ must not exceed $V_{\text{Dd}5} + 0.3 \text{ V}$.

- *3 :
- Use within recommended operating conditions.
 - Use with DC voltage (current).
 - +B signals are input signals that exceed the $V_{\text{Dd}5}$ voltage. +B signals should always be applied by connecting a limiting resistor between the +B signal and the microcontroller.
 - The value of the limiting resistor should be set so that the current input to the microcontroller pin does not exceed the rated value at any time, either instantaneously or for an extended period, when the +B signal is input.
 - Note that when the microcontroller drive current is low, such as in the low power consumption modes, the +B input potential can increase the potential at the power supply pin via a protective diode, possibly affecting other devices.

- Note that if the +B signal is input when the microcontroller is off (not fixed at 0 V), power is supplied through the +B input pin; therefore, the microcontroller may partially operate.
- Note that if the +B signal is input at power-on, since the power is supplied through the pin, the power-on reset may not function in the power supply voltage.
- Do not leave +B input pins open.
- Example of recommended circuit :

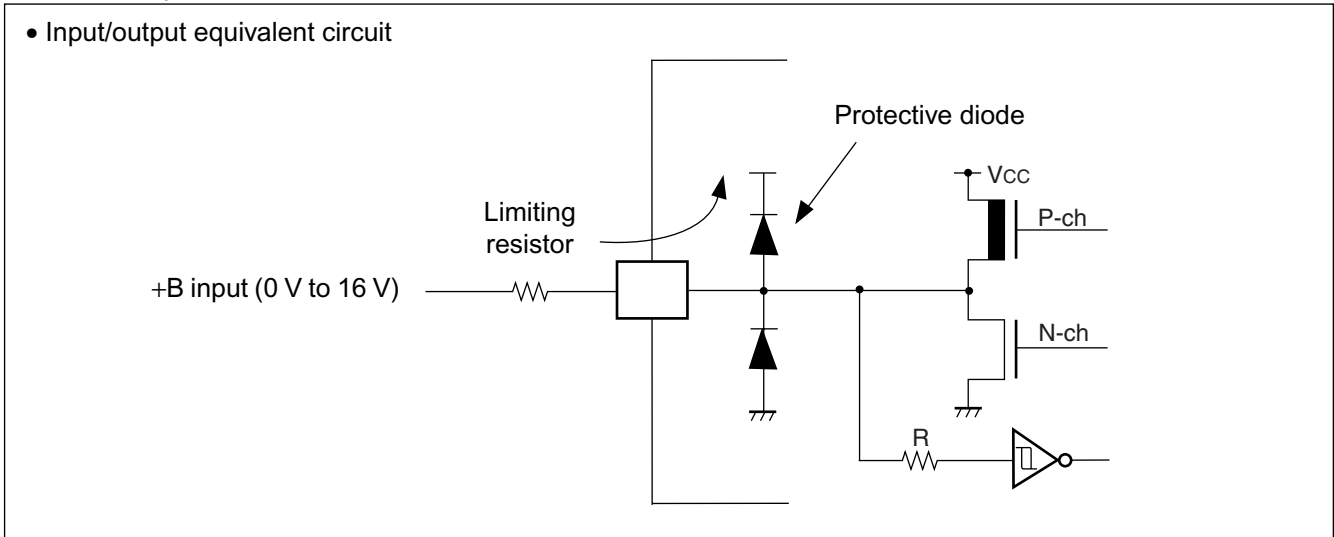

*4 : Maximum output current is defined as the value of the peak current flowing through any one of the corresponding pins.

*5 : Average output current is defined as the value of the average current flowing through any one of the corresponding pins for a 100 ms period.

*6 : Total average output current is defined as the value of the average current flowing through all of the corresponding pins for a 100 ms period.

*7 : The maximum permitted power dissipation depends on the ambient temperature, the air flow velocity and the thermal conductance of the package on the PCB.

The actual power dissipation depends on the customer application and can be calculated as follows:

$$P_D = P_{IO} + P_{INT}$$

$$P_{IO} = \sum (|V_{SS}-V_{OL}| * I_{OL} + |V_{DD}-V_{OH}| * I_{OH}) \quad (\text{IO load power dissipation, sum is performed on all IO ports})$$

$$P_{INT} = V_{DD}5R * I_{CC} + AV_{CC}5 * I_A + AVRH5 * I_R \quad (\text{internal power dissipation})$$

*8 : Worst case value for the BGA package mounted on a 4-layer PCB at specified T_A without air flow.

*9 : Please contact Fujitsu's representative for reliability limitations when using under these conditions.

*10: Applicable only for devices with $T_{A(max)} \geq T_A$.

WARNING: Semiconductor devices can be permanently damaged by application of stress (voltage, current, temperature, etc.) in excess of absolute maximum ratings. Do not exceed these ratings.

MB91460Q Series

2. Recommended operating conditions

(V_{SS5} = AV_{SS5} = 0.0 V)

Parameter	Symbol	Value			Unit	Remarks
		Min	Typ	Max		
Power supply voltage	V _{DD5}	3.0	—	5.5	V	
	V _{DD5R}	3.0	—	5.5	V	Internal regulator
	V _{DD35}	3.0	—	5.5	V	External bus
	AV _{CC5}	3.0	—	5.5	V	A/D converter
Smoothing capacitor at VCC18C pin	C _s	—	4.7	—	μF	Use a X7R ceramic capacitor or a capacitor that has similar frequency characteristics.
Power supply slew rate		—	—	50	V/ms	
Operating temperature	T _A	− 40	—	T _{A(max)}	°C	For T _{A(max)} , refer to the ordering information
Main Oscillation stabilisation time		10			ms	
Lock-up time PLL (4 MHz -> 16 ... 100MHz)				0.6	ms	
ESD Protection (Human body model)	V _{surge}	2			kV	R _{discharge} = 1.5kΩ C _{discharge} = 100pF
RC Oscillator	f _{RC100kHz}	50	100	200	kHz	V _{DDCORE} ≥ 1.65V
	f _{RC2MHz}	1	2	4	MHz	

WARNING: The recommended operating conditions are required in order to ensure the normal operation of the semiconductor device. All of the device's electrical characteristics are warranted when the device is operated within these ranges.

Always use semiconductor devices within their recommended operating condition ranges. Operation outside these ranges may adversely affect reliability and could result in device failure.

No warranty is made with respect to uses, operating conditions, or combinations not represented on the data sheet. Users considering application outside the listed conditions are advised to contact their FUJITSU representatives beforehand.

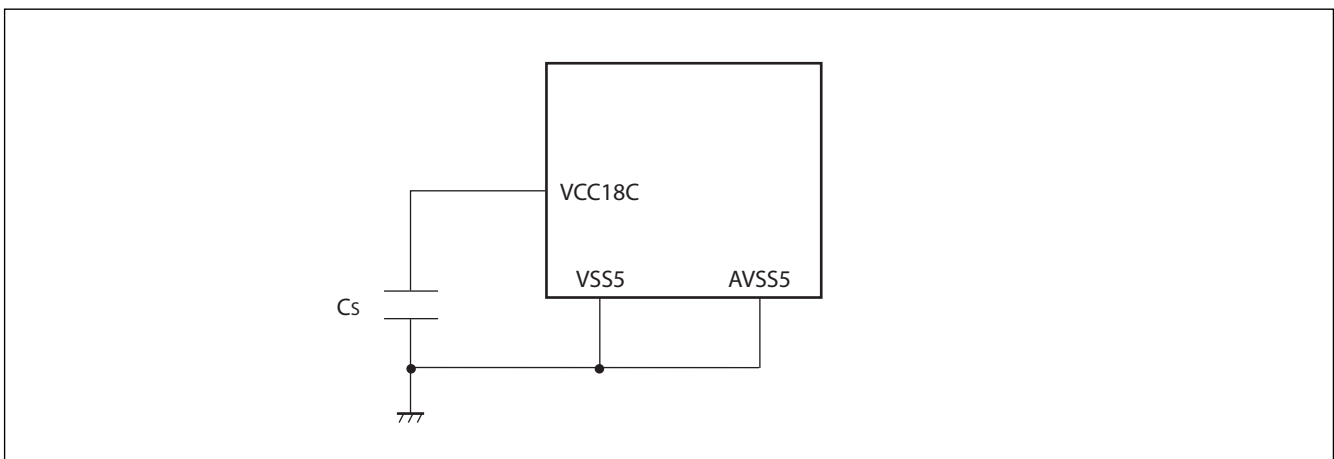

MB91460Q Series

3. DC characteristics

Note: In the following tables, “V_{DD}” means V_{DD35} for pins of ext. bus or V_{DD5} for other pins.

In the following tables, “V_{SS}” means V_{SS5} for all pins.

(V_{DD5} = AV_{CC5} = 3.0 V to 5.5 V, V_{SS5} = AV_{SS5} = 0 V, T_A = -40 °C to T_{A(max)})

Parameter	Symbol	Pin name	Condition	Value			Unit	Remarks
				Min	Typ	Max		
Input “H” voltage	V _{IH}	—	Port inputs if CMOS Hysteresis 0.8/0.2 input is selected	0.8 × V _{DD}	—	V _{DD} + 0.3	V	CMOS hysteresis input
		—	Port inputs if CMOS Hysteresis 0.7/0.3 input is selected	0.7 × V _{DD}	—	V _{DD} + 0.3	V	4.5 V ≤ V _{DD} ≤ 5.5 V
				0.74 × V _{DD}	—	V _{DD} + 0.3	V	3 V ≤ V _{DD} < 4.5 V
		—	AUTOMOTIVE Hysteresis input is selected	0.8 × V _{DD}	—	V _{DD} + 0.3	V	
	—	Port inputs if TTL input is selected	2.0	—	V _{DD} + 0.3	V		
	V _{IHR}	INITX	—	0.8 × V _{DD}	—	V _{DD} + 0.3	V	INITX input pin (CMOS Hysteresis)
	V _{IHM}	MD_2 to MD_0	—	V _{DD} - 0.3	—	V _{DD} + 0.3	V	Mode input pins
	V _{IHX0S}	X0, X0A	—	2.5	—	V _{DD} + 0.3	V	External clock in “Oscillation mode”
V _{IHX0F}	X0	—	0.8 × V _{DD}	—	V _{DD} + 0.3	V	External clock in “Fast Clock Input mode”	
Input “L” voltage	V _{IL}	—	Port inputs if CMOS Hysteresis 0.8/0.2 input is selected	V _{SS} - 0.3	—	0.2 × V _{DD}	V	
		—	Port inputs if CMOS Hysteresis 0.7/0.3 input is selected	V _{SS} - 0.3	—	0.3 × V _{DD}	V	
				—	Port inputs if AUTOMOTIVE Hysteresis input is selected	V _{SS} - 0.3	—	0.5 × V _{DD}
		V _{SS} - 0.3	—			0.46 × V _{DD}	V	3 V ≤ V _{DD} < 4.5 V
	—	Port inputs if TTL input is selected	V _{SS} - 0.3	—	0.8	V		
	V _{ILR}	INITX	—	V _{SS} - 0.3	—	0.2 × V _{DD}	V	INITX input pin (CMOS Hysteresis)
	V _{ILM}	MD_2 to MD_0	—	V _{SS} - 0.3	—	V _{SS} + 0.3	V	Mode input pins
	V _{ILXDS}	X0, X0A	—	V _{SS} - 0.3	—	0.5	V	External clock in “Oscillation mode”

MB91460Q Series

($V_{DD5} = AV_{CC5} = 3.0\text{ V to }5.5\text{ V}$, $V_{SS5} = AV_{SS5} = 0\text{ V}$, $T_A = -40\text{ }^\circ\text{C to }T_{A(max)}$)

Parameter	Symbol	Pin name	Condition	Value			Unit	Remarks
				Min	Typ	Max		
Input "L" voltage	V_{ILXDF}	X0	—	$V_{SS} - 0.3$	—	$0.2 \times V_{DD}$	V	External clock in "Fast Clock Input mode"
Output "H" voltage	V_{OH2}	Normal outputs	$4.5\text{V} \leq V_{DD} \leq 5.5\text{V}$, $I_{OH} = -2\text{mA}$	$V_{DD} - 0.5$	—	—	V	Driving strength set to 2 mA
			$3.0\text{V} \leq V_{DD} \leq 4.5\text{V}$, $I_{OH} = -1.6\text{mA}$					
	V_{OH5}	Normal outputs	$4.5\text{V} \leq V_{DD} \leq 5.5\text{V}$, $I_{OH} = -5\text{mA}$	$V_{DD} - 0.5$	—	—	V	Driving strength set to 5 mA
$3.0\text{V} \leq V_{DD} \leq 4.5\text{V}$, $I_{OH} = -3\text{mA}$								
	V_{OH3}	I ² C outputs	$3.0\text{V} \leq V_{DD} \leq 5.5\text{V}$, $I_{OH} = -3\text{mA}$	$V_{DD} - 0.5$	—	—	V	
Output "L" voltage	V_{OL2}	Normal outputs	$4.5\text{V} \leq V_{DD} \leq 5.5\text{V}$, $I_{OH} = +2\text{mA}$	—	—	0.4	V	Driving strength set to 2 mA
			$3.0\text{V} \leq V_{DD} \leq 4.5\text{V}$, $I_{OH} = +1.6\text{mA}$					
	V_{OL5}	Normal outputs	$4.5\text{V} \leq V_{DD} \leq 5.5\text{V}$, $I_{OH} = +5\text{mA}$	—	—	0.4	V	Driving strength set to 5 mA
$3.0\text{V} \leq V_{DD} \leq 4.5\text{V}$, $I_{OH} = +3\text{mA}$								
	V_{OL3}	I ² C outputs	$3.0\text{V} \leq V_{DD} \leq 5.5\text{V}$, $I_{OH} = +3\text{mA}$	—	—	0.4	V	
Input leakage current	I_{IL}	Pnn_m *1	$3.0\text{V} \leq V_{DD} \leq 5.5\text{V}$ $V_{SS5} < V_i < V_{DD}$ $T_A = 25\text{ }^\circ\text{C}$	-1	—	+1	μA	$V_{SS5} < V_i < V_{DD}$
			$3.0\text{V} \leq V_{DD} \leq 5.5\text{V}$ $V_{SS5} < V_i < V_{DD}$ $T_A = T_{A(max)}$	-3	—	+3		

1. Pnn_m includes all GPIO pins. Analog (AN) channels and PullUp/PullDown are disabled.

MB91460Q Series

($V_{DD5} = AV_{CC5} = 3.0\text{ V to }5.5\text{ V}$, $V_{SS5} = AV_{SS5} = 0\text{ V}$, $T_A = -40\text{ }^\circ\text{C to }T_{A(max)}$)

Parameter	Symbol	Pin name	Condition	Value			Unit	Remarks
				Min	Typ	Max		
Analog input leakage current	I_{AIN}	ANn *1	$3.0\text{V} \leq V_{DD} \leq 5.5\text{V}$ $T_A = 25\text{ }^\circ\text{C}$	- 1	—	+ 1	μA	$AV_{SS5} < V_I < AV_{CC5}$, $AV_{SS5} < V_I < AVR_{H5}$
			$3.0\text{V} \leq V_{DD} \leq 5.5\text{V}$ $T_A = T_{A(max)}$	- 3	—	+ 3	μA	
Pull-up resistance	R_{UP}	Pnn_m *2 INITX	$3.0\text{V} \leq V_{DD} \leq 3.6\text{V}$	40	100	160	k Ω	
			$4.5\text{V} \leq V_{DD} \leq 5.5\text{V}$	25	50	100		
Pull-down resistance	R_{DOWN}	Pnn_m *3	$3.0\text{V} \leq V_{DD} \leq 3.6\text{V}$	40	100	180	k Ω	
			$4.5\text{V} \leq V_{DD} \leq 5.5\text{V}$	25	50	100		
Input capacitance	C_{IN}	All except V_{DD5} , V_{DD5R} , V_{SS5} , AV_{CC5} , AV_{SS} , AVR_{H5}	$f = 1\text{ MHz}$	-	5	15	pF	
Power supply current MB91 F469QA, MB91 F469QAH	I_{CC}	V_{DD5R}	CLKB: 100 MHz CLKP: 50 MHz CLKT: 50 MHz CLKCAN: 50 MHz	—	140	170	mA	Code fetch from Flash
	I_{CCH}	V_{DD5R}	$T_A = +25\text{ }^\circ\text{C}$	—	50	210	μA	At stop mode *4
			$T_A = +105\text{ }^\circ\text{C}$	—	0.6	2.8	mA	
			$T_A = +125\text{ }^\circ\text{C}$	—	1.4	5.8	mA	
			$T_A = +25\text{ }^\circ\text{C}$	—	120	560	μA	RTC : 4 MHz mode *4
			$T_A = +105\text{ }^\circ\text{C}$	—	0.7	3.2	mA	
			$T_A = +125\text{ }^\circ\text{C}$	—	1.5	7.2	mA	
			$T_A = +25\text{ }^\circ\text{C}$	—	70	310	μA	
	$T_A = +105\text{ }^\circ\text{C}$	—	0.65	3.0	mA			
	$T_A = +125\text{ }^\circ\text{C}$	—	1.45	6.0	mA			
I_{LVE}	V_{DD5}	—	—	70	150	μA	External low voltage detection	
I_{LVI}	V_{DD5R}	—	—	50	100	μA	Internal low voltage detection	
I_{OSC}	V_{DD5}	—	—	250	500	μA	Main clock (4 MHz)	
		—	—	20	40	μA	Sub clock (32 kHz)	

1. ANn includes all pins where AN channels are enabled.
2. Pnn_m includes all GPIO pins. The pull up resistors must be enabled by PPER/PPCR setting and the pins must be in input direction.
3. Pnn_m includes all GPIO pins. The pull down resistors must be enabled by PPER/PPCR setting and the pins must be in input direction.
4. Main regulator OFF, sub regulator set to 1.2V, Low voltage detection disabled.
5. Main regulator OFF, sub regulator set to 1.2V, Low voltage detection disabled, RC oscillator disabled. Additional current consumption of Sub oscillator I_{OSC} has to be taken into account.

MB91460Q Series

4. A/D converter characteristics

($V_{DD5} = AV_{CC5} = 3.0\text{ V to }5.5\text{ V}$, $V_{SS5} = AV_{SS5} = 0\text{ V}$, $T_A = -40\text{ }^\circ\text{C to }T_{A(max)}$)

Parameter	Symbol	Pin name	Value			Unit	Remarks
			Min	Typ	Max		
Resolution	—	—	—	—	10	bit	
Total error	—	—	-3	—	+3	LSB	
Nonlinearity error	—	—	-2.5	—	+2.5	LSB	
Differential nonlinearity error	—	—	-1.9	—	+1.9	LSB	
Zero reading voltage	V_{OT}	ANn	$AV_{RL} - 1.5\text{ LSB}$	$AV_{RL} + 0.5\text{ LSB}$	$AV_{RL} + 2.5\text{ LSB}$	V	
Full scale reading voltage	V_{FST}	ANn	$AV_{RH} - 3.5\text{ LSB}$	$AV_{RH} - 1.5\text{ LSB}$	$AV_{RH} + 0.5\text{ LSB}$	V	
Compare time	T_{comp}	—	0.6	—	t.b.d. ¹	μs	$4.5\text{ V} \leq AV_{CC5} \leq 5.5\text{ V}$
			2.0	—	t.b.d. ¹	μs	$3.0\text{ V} \leq AV_{CC5} \leq 4.5\text{ V}$
Sampling time	T_{samp}	—	0.4	—	—	μs	$4.5\text{ V} \leq AV_{CC5} \leq 5.5\text{ V}$, $R_{EXT} < 2\text{ k}\Omega$
			1.0	—	—	μs	$3.0\text{ V} \leq AV_{CC5} \leq 4.5\text{ V}$, $R_{EXT} < 1\text{ k}\Omega$
Conversion time	T_{conv}	—	1.0	—	—	μs	$4.5\text{ V} \leq AV_{CC5} \leq 5.5\text{ V}$
			3.0	—	—	μs	$3.0\text{ V} \leq AV_{CC5} \leq 4.5\text{ V}$
Input capacitance	C_{IN}	ANn	—	—	11	pF	
Input resistance	R_{IN}	ANn	—	—	2.6	k Ω	$4.5\text{ V} \leq AV_{CC5} \leq 5.5\text{ V}$
			—	—	12.1	k Ω	$3.0\text{ V} \leq AV_{CC5} \leq 4.5\text{ V}$
Analog input leakage current	I_{AIN}	ANn	-1	—	+1	μA	$T_A = +25\text{ }^\circ\text{C}$
			-3	—	+3	μA	$T_A = T_{A(max)}$
Analog input voltage range	V_{AIN}	ANn	AV_{RL}	—	AV_{RH}	V	
Offset between input channels	—	ANn	—	—	4	LSB	

1. Parameter is under re-evaluation.

(Continued)

Note : The accuracy gets worse as $AV_{RH} - AV_{RL}$ becomes smaller

(Continued)

Parameter	Symbol	Pin name	Value			Unit	Remarks
			Min	Typ	Max		
Reference voltage range	AVRH	AVRH5	$0.75 \times AV_{CC5}$	—	AV_{CC5}	V	
	AVRL	AVSS5	AV_{SS5}	—	$AV_{CC5} \times 0.25$	V	
Power supply current	I _A	AV _{CC5}	—	2.5	5	mA	A/D Converter active
	I _{AH}	AV _{CC5}	—	—	5	μA	A/D Converter not operated *1
Reference voltage current	I _R	AVRH5	—	0.7	1	mA	A/D Converter active
	I _{RH}	AVRH5	—	—	5	μA	A/D Converter not operated *2

*1 : Supply current at AV_{CC5}, if A/D converter and ALARM comparator are not operating, (V_{DD5} = AV_{CC5} = AVRH = 5.0 V)

*2 : Input current at AVRH5, if A/D converter is not operating, (V_{DD5} = AV_{CC5} = AVRH = 5.0 V)

Sampling Time Calculation

$$T_{\text{samp}} = (2.6 \text{ k}\Omega + R_{\text{EXT}}) \times 11 \text{ pF} \times 7; \text{ for } 4.5 \text{ V} \leq AV_{\text{CC5}} \leq 5.5 \text{ V}$$

$$T_{\text{samp}} = (12.1 \text{ k}\Omega + R_{\text{EXT}}) \times 11 \text{ pF} \times 7; \text{ for } 3.0 \text{ V} \leq AV_{\text{CC5}} \leq 4.5 \text{ V}$$

Conversion Time Calculation

$$T_{\text{conv}} = T_{\text{samp}} + T_{\text{comp}}$$

Definition of A/D converter terms

- Resolution
Analog variation that is recognizable by the A/D converter.
- Nonlinearity error
Deviation between actual conversion characteristics and a straight line connecting the zero transition point (00 0000 0000_B ↔ 00 0000 0001_B) and the full scale transition point (11 1111 1110_B ↔ 11 1111 1111_B).
- Differential nonlinearity error
Deviation of the input voltage from the ideal value that is required to change the output code by 1 LSB.
- Total error
This error indicates the difference between actual and theoretical values, including the zero transition error, full scale transition error, and nonlinearity error.

MB91460Q Series

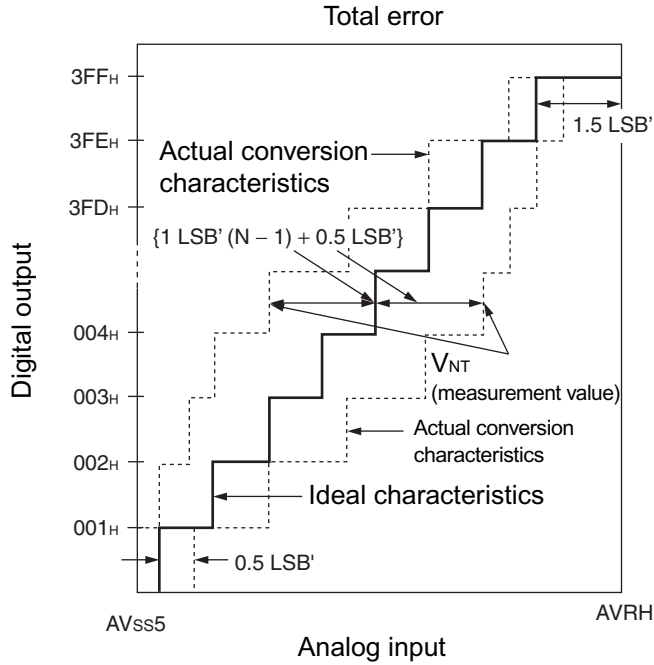

$$1\text{LSB}' (\text{ideal value}) = \frac{\text{AVRH} - \text{AV}_{\text{SS5}}}{1024} [\text{V}]$$

$$\text{Total error of digital output } N = \frac{V_{\text{NT}} - \{1\text{LSB}' \times (N - 1) + 0.5\text{LSB}'\}}{1\text{LSB}'}$$

N : A/D converter digital output value

V_{OT'} (ideal value) = AV_{SS5} + 0.5 LSB' [V]

V_{FST'} (ideal value) = AV_{RH} - 1.5 LSB' [V]

V_{NT} : Voltage at which the digital output changes from (N + 1)_H to N_H

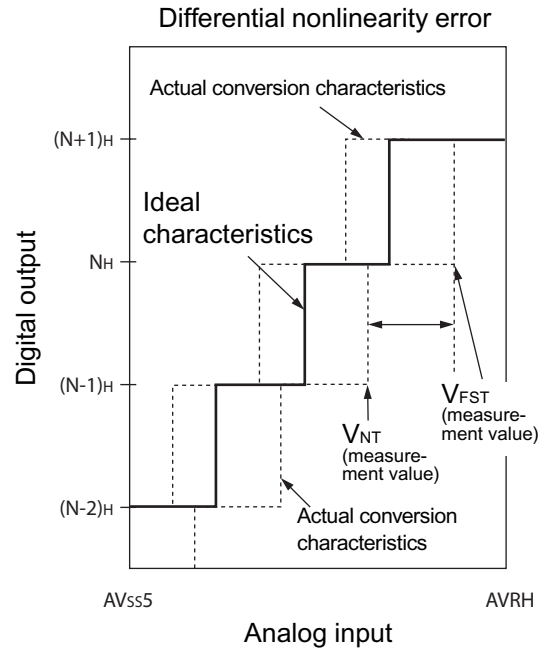
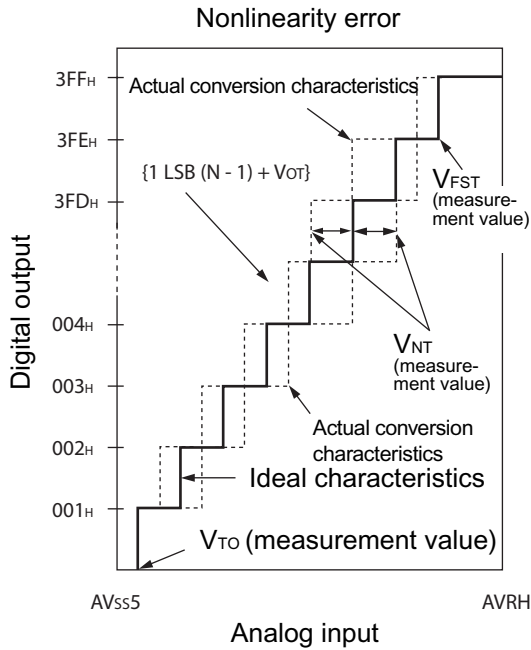

$$\text{Nonlinearity error of digital output } N = \frac{V_{NT} - \{1\text{LSB} \times (N - 1) + V_{OT}\}}{1\text{LSB}} \text{ [LSB]}$$

$$\text{Differential nonlinearity error of digital output } N = \frac{V_{(N+1)T} - V_{NT}}{1\text{LSB}} - 1 \text{ [LSB]}$$

$$1\text{LSB} = \frac{V_{FST} - V_{OT}}{1022} \text{ [V]}$$

N : A/D converter digital output value

V_{OT} : Voltage at which the digital output changes from 000H to 001H.

V_{FST} : Voltage at which the digital output changes from 3FEH to 3FFH.

MB91460Q Series

5. Alarm comparator characteristics

Parameter	Symbol	Pin name	Value			Unit	Remarks
			Min	Typ	Max		
Power supply current	I _{A5ALMF}	AV _{CC5}	—	25	40	μA	Alarm comparator enabled in fast mode (per channel) *1
	I _{A5ALMS}		—	7	10	μA	Alarm comparator enabled in normal mode (per channel) *1
	I _{A5ALMH}		—	—	5	μA	Alarm comparator disabled
ALARM pin input current	I _{ALIN}	ALARM _n	- 1	—	+ 1	μA	T _A =25 °C
			- 3	—	+ 3	μA	T _A =T _{A(max)}
ALARM pin input voltage range	V _{ALIN}		0	—	AV _{CC5}	V	
Alarm upper limit voltage	V _{IAH}		AV _{CC5} × 0.78 - 3%	AV _{CC5} × 0.78	AV _{CC5} × 0.78 + 3%	V	
Alarm lower limit voltage	V _{IAL}		AV _{CC5} × 0.36 - 5%	AV _{CC5} × 0.36	AV _{CC5} × 0.36 + 5%	V	
Alarm hysteresis voltage	V _{IAHYS}		50	—	250	mV	
Alarm input resistance	R _{IN}		5	—	—	MΩ	
Comparison time	t _{COMPF}		—	0.1	0.2	μs	Alarm comparator enabled in fast mode *1
	t _{COMPS}	—	1	2	μs	Alarm comparator enabled in normal mode *1	

Note: *1 : The fast Alarm Comparator mode is enabled by setting ACSR.MD=1
Setting ACSR.MD=0 sets the normal mode.

6. FLASH memory program/erase characteristics

6.1. MB91F469QA

($T_A = 25^\circ\text{C}$, $V_{CC} = 5.0\text{V}$)

Parameter	Value			Unit	Remarks
	Min	Typ	Max		
Sector erase time	-	0.5	2.0	s	Erasure programming time not included
Chip erase time	-	n*0.5	n*2.0	s	n is the number of Flash sector of the device
Word (16 or 32-bit width) programming time	-	6	100	μs	System overhead time not included
Programme/Erase cycle	10 000			cycle	
Flash data retention time	20			year	*1

*1: This value was converted from the results of evaluating the reliability of the technology (using Arrhenius equation to convert high temperature measurements into normalized value at 85°C)

MB91460Q Series

7. AC characteristics

7.1. Clock timing

($V_{DD5} = 3.0\text{ V to }5.5\text{ V}$, $V_{SS5} = AV_{SS5} = 0\text{ V}$, $T_A = -40\text{ }^{\circ}\text{C to }T_{A(max)}$)

Parameter	Symbol	Pin name	Value			Unit	Condition
			Min	Typ	Max		
Clock frequency	f_c	X0 X1	3.5	4	16	MHz	Opposite phase external supply or crystal
		X0A X1A	32	32.768	100	kHz	

- Clock timing conditions

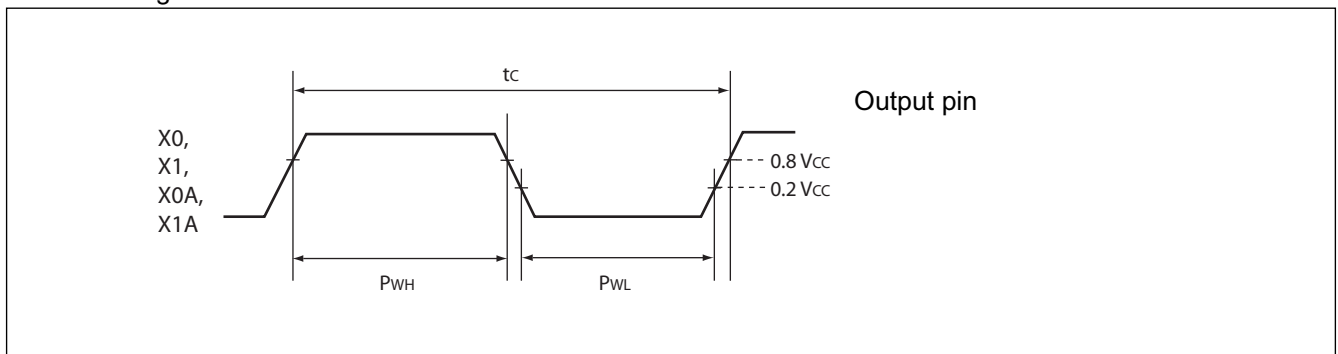

7.2. Reset input ratings

($V_{DD5} = 3.0\text{ V to }5.5\text{ V}$, $V_{SS5} = AV_{SS5} = 0\text{ V}$, $T_A = -40\text{ }^\circ\text{C to }T_{A(max)}$)

Parameter	Symbol	Pin name	Condition	Value		Unit
				Min	Max	
INITX input time (at power-on)	t_{INTL}	INITX	—	10	—	ms
INITX input time (other than the above)				20	—	μs

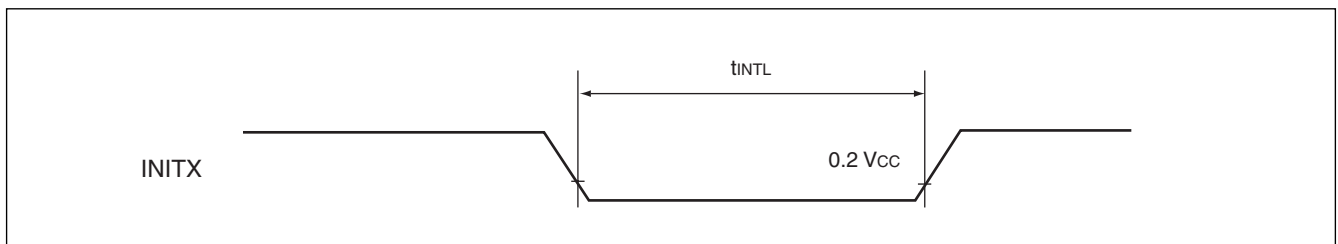

MB91460Q Series

7.3. LIN-USART Timings at V_{DD5} = 3.0 to 5.5 V

- Conditions during AC measurements
- All AC tests were measured under the following conditions:
 - I_{Odrive} = 5 mA
 - V_{DD5} = 3.0 V to 5.5 V, I_{load} = 3 mA
 - V_{SS5} = 0 V
 - T_A = -40 °C to T_{A(max)}
 - C_i = 50 pF (load capacity value of pins when testing)
 - VOL = 0.2 x V_{DD5}
 - VOH = 0.8 x V_{DD5}
 - EPILR = 0, PILR = 1 (Automotive Level == worst case)

(V_{DD5} = 3.0 V to 5.5 V, V_{SS5} = AV_{SS5} = 0 V, T_A = -40 °C to T_{A(max)})

Parameter	Symbol	Pin name	Condition	V _{DD5} = 3.0 V to 4.5 V		V _{DD5} = 4.5 V to 5.5 V		Unit
				Min	Max	Min	Max	
Serial clock cycle time	t _{SCYCI}	SCKn	Internal clock operation (master mode)	4 t _{CLKP}	—	4 t _{CLKP}	—	ns
SCK ↓ → SOT delay time	t _{SLOVI}	SCKn SOTn		- 30	30	- 20	20	ns
SOT → SCK ↓ delay time	t _{OVSHI}	SCKn SOTn		m × t _{CLKP} - 30*	—	m × t _{CLKP} - 20*	—	ns
Valid SIN → SCK ↑ setup time	t _{IVSHI}	SCKn SINn		t _{CLKP} + 55	—	t _{CLKP} + 45	—	ns
SCK ↑ → valid SIN hold time	t _{SHIXI}	SCKn SINn		0	—	0	—	ns
Serial clock "H" pulse width	t _{SHSLE}	SCKn	External clock operation (slave mode)	t _{CLKP} + 10	—	t _{CLKP} + 10	—	ns
Serial clock "L" pulse width	t _{SLSHE}	SCKn		t _{CLKP} + 10	—	t _{CLKP} + 10	—	ns
SCK ↓ → SOT delay time	t _{SLOVE}	SCKn SOTn		—	2 t _{CLKP} + 55	—	2 t _{CLKP} + 45	ns
Valid SIN → SCK ↑ setup time	t _{IVSHE}	SCKn SINn		10	—	10	—	ns
SCK ↑ → valid SIN hold time	t _{SHIXE}	SCKn SINn		t _{CLKP} + 10	—	t _{CLKP} + 10	—	ns
SCK rising time	t _{FE}	SCKn		—	20	—	20	ns
SCK falling time	t _{RE}	SCKn		—	20	—	20	ns

* : Parameter m depends on t_{SCYCI} and can be calculated as :

- if t_{SCYCI} = 2*k*t_{CLKP}, then m = k, where k is an integer > 2
- if t_{SCYCI} = (2*k + 1)*t_{CLKP}, then m = k + 1, where k is an integer > 1

Notes : • The above values are AC characteristics for CLK synchronous mode.
• t_{CLKP} is the cycle time of the peripheral clock.

- Internal clock mode (master mode)

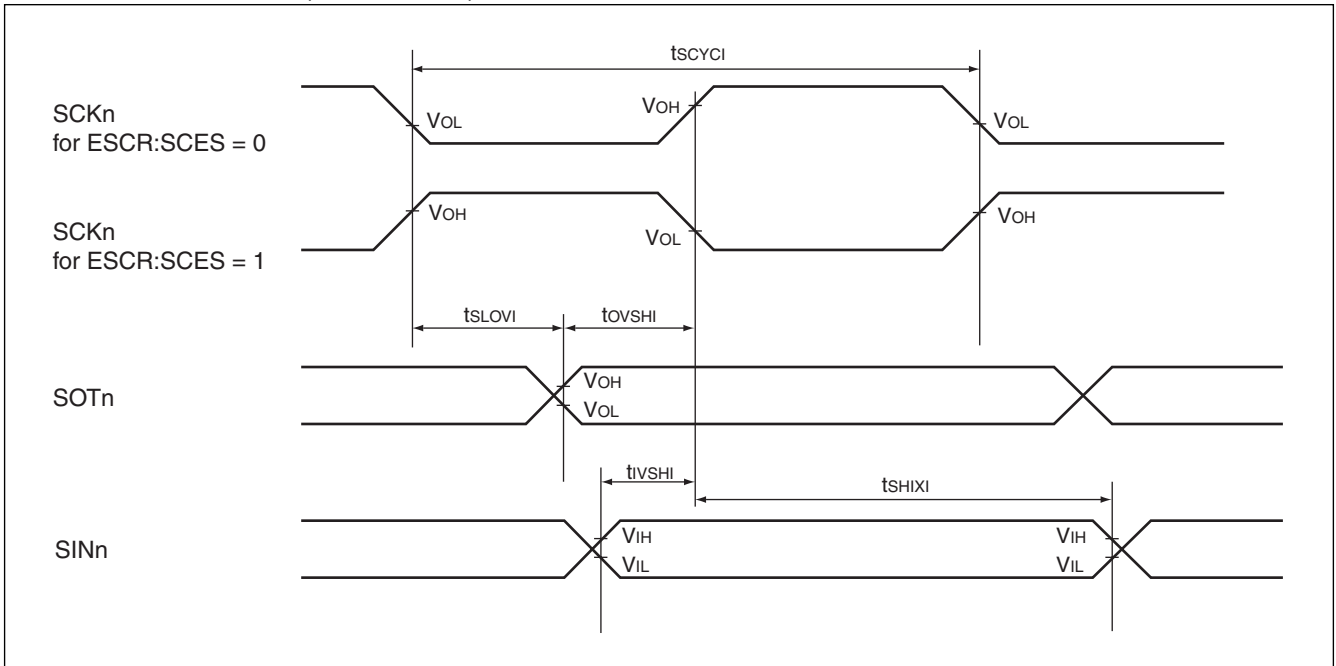

- External clock mode (slave mode)

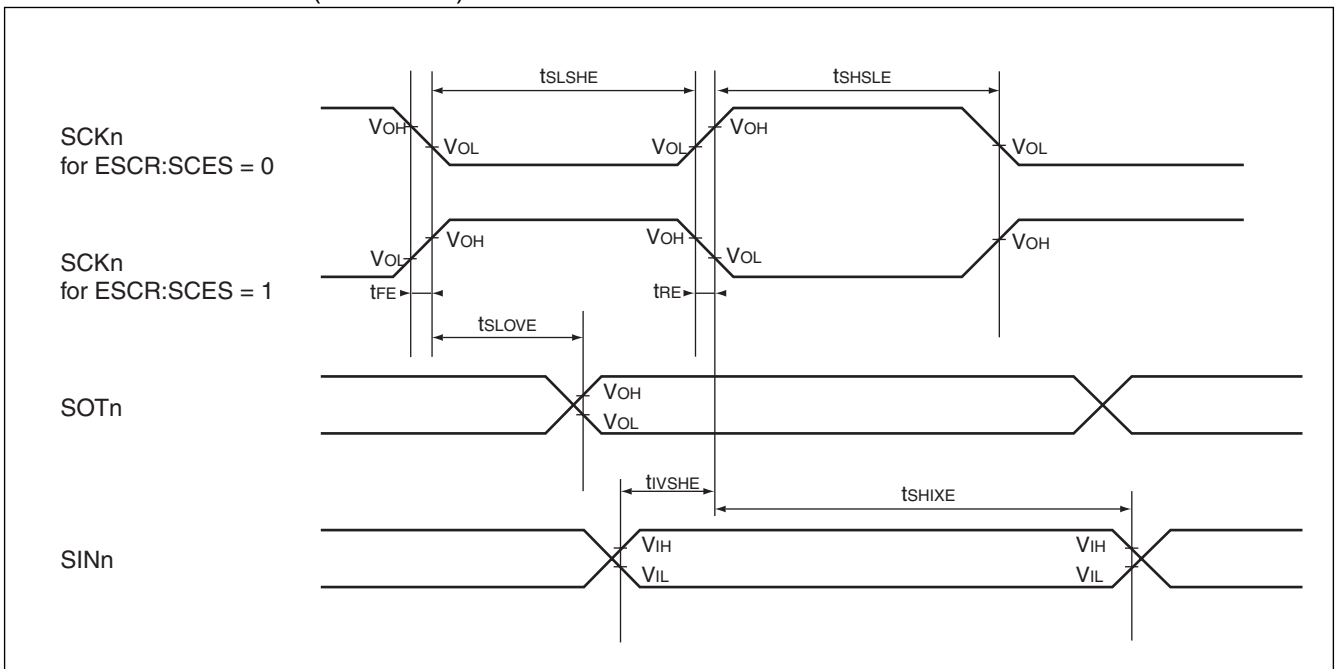

MB91460Q Series

7.4. I²C AC Timings at V_{DD5} = 3.0 to 5.5 V

- Conditions during AC measurements

All AC tests were measured under the following conditions:

- I_{Odrive} = 3 mA
- V_{DD5} = 3.0 V to 5.5 V, I_{load} = 3 mA
- V_{SS5} = 0 V
- T_A = -40 °C to T_{A(max)}
- C_I = 50 pF
- VOL = 0.3 × V_{DD5}
- VOH = 0.7 × V_{DD5}
- EPILR = 0, PILR = 0 (CMOS Hysteresis 0.3 × V_{DD5}/0.7 × V_{DD5})

Fast mode:

(V_{DD5} = 3.5 V to 5.5 V, V_{SS5} = AV_{SS5} = 0 V, T_A = -40 °C to T_{A(max)})

Parameter	Symbol	Pin name	Value		Unit	Remark
			Min	Max		
SCL clock frequency	f _{SCL}	SCLn	0	400	kHz	
Hold time (repeated) START condition. After this period, the first clock pulse is generated	t _{HD;STA}	SCLn, SDAn	0.6	—	μs	
LOW period of the SCL clock	t _{LOW}	SCLn	1.3	—	μs	
HIGH period of the SCL clock	t _{HIGH}	SCLn	0.6	—	μs	
Setup time for a repeated START condition	t _{SU;STA}	SCLn, SDAn	0.6	—	μs	
Data hold time for I ² C-bus devices	t _{HD;DAT}	SCLn, SDAn	0	0.9	μs	
Data setup time	t _{SU;DAT}	SCLn, SDAn	100	—	ns	
Rise time of both SDA and SCL signals	t _r	SCLn, SDAn	20 + 0.1Cb	300	ns	
Fall time of both SDA and SCL signals	t _f	SCLn, SDAn	20 + 0.1Cb	300	ns	
Setup time for STOP condition	t _{SU;STO}	SCLn, SDAn	0.6	—	μs	
Bus free time between a STOP and START condition	t _{BUF}	SCLn, SDAn	1.3	—	μs	
Capacitive load for each bus line	C _b	SCLn, SDAn	—	400	pF	
Pulse width of spike suppressed by input filter	t _{SP}	SCLn, SDAn	0	(1..1.5) × t _{CLKP}	ns	*1

*1 The noise filter will suppress single spikes with a pulse width of 0ns and between (1 to 1.5) cycles of peripheral clock, depending on the phase relationship between I2C signals (SDA, SCL) and peripheral clock.

Note: t_{CLKP} is the cycle time of the peripheral clock.

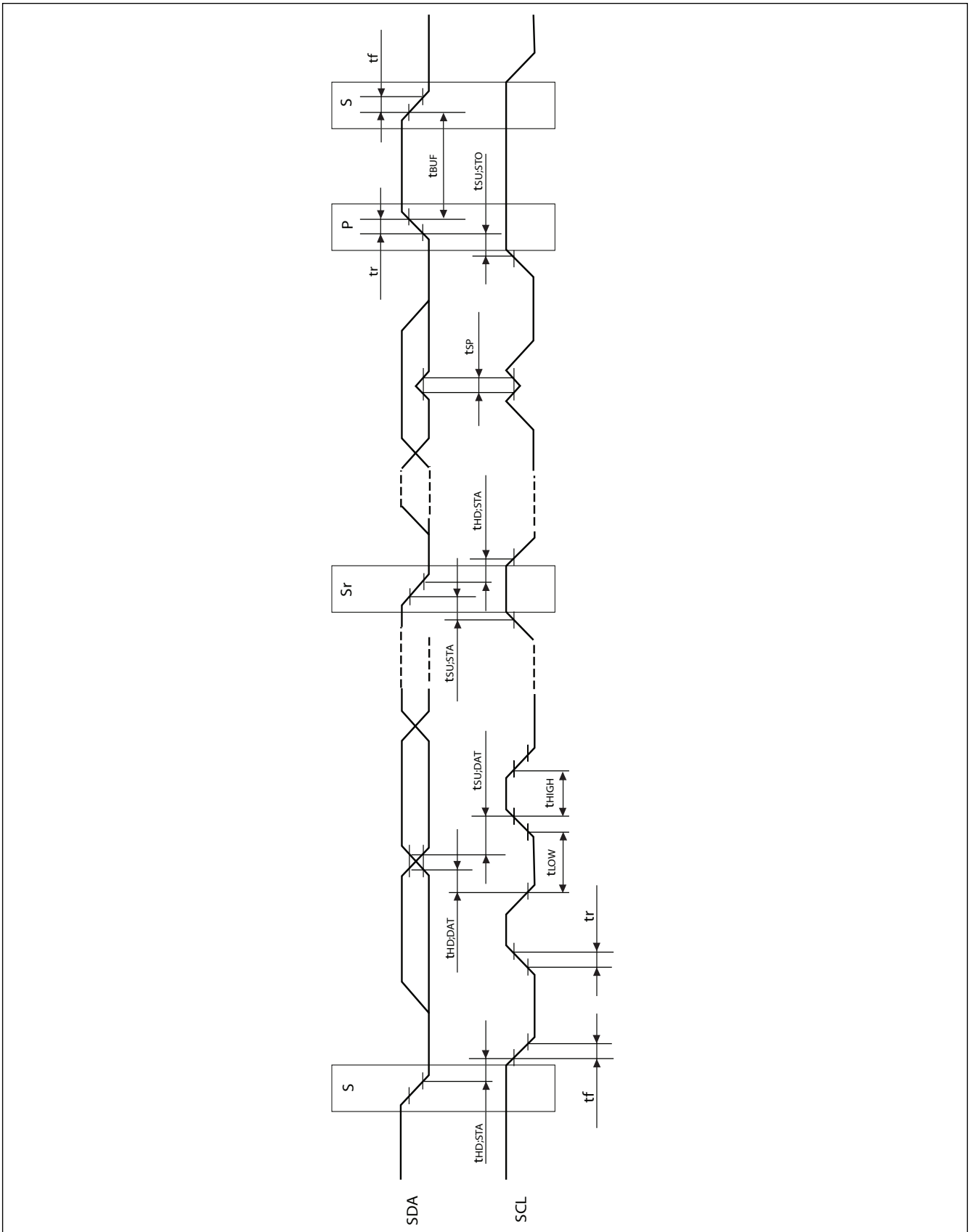

MB91460Q Series

7.5. Free-run timer clock

($V_{DD5} = 3.0\text{ V to }5.5\text{ V}$, $V_{SS5} = AV_{SS5} = 0\text{ V}$, $T_A = -40\text{ }^\circ\text{C to }T_{A(max)}$)

Parameter	Symbol	Pin name	Condition	Value		Unit
				Min	Max	
Input pulse width	t_{TIWH} t_{TIWL}	CKn	—	$4t_{CLKP}$	—	ns

Note : t_{CLKP} is the cycle time of the peripheral clock.

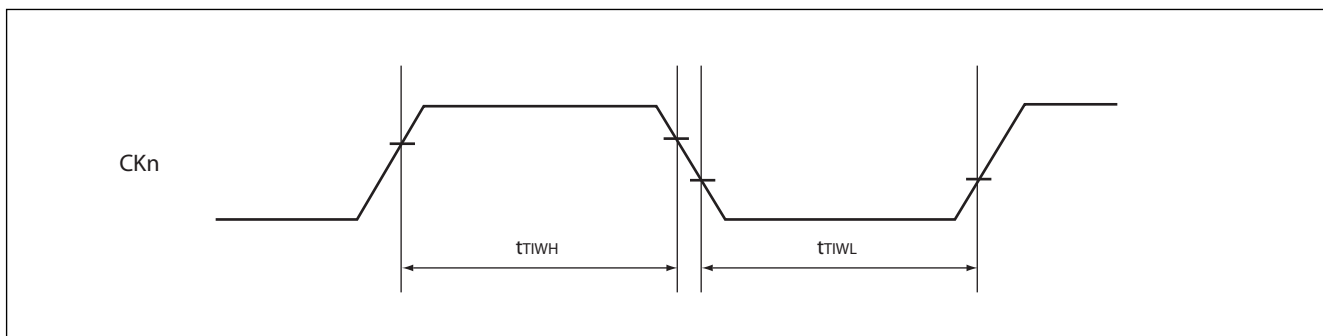

7.6. Trigger input timing

($V_{DD5} = 3.0\text{ V to }5.5\text{ V}$, $V_{SS5} = AV_{SS5} = 0\text{ V}$, $T_A = -40\text{ }^\circ\text{C to }T_{A(max)}$)

Parameter	Symbol	Pin name	Condition	Value		Unit
				Min	Max	
Input capture input trigger	t_{INP}	ICUn	—	$5t_{CLKP}$	—	ns
A/D converter trigger	t_{ATGX}	ATGX	—	$5t_{CLKP}$	—	ns

Note : t_{CLKP} is the cycle time of the peripheral clock.

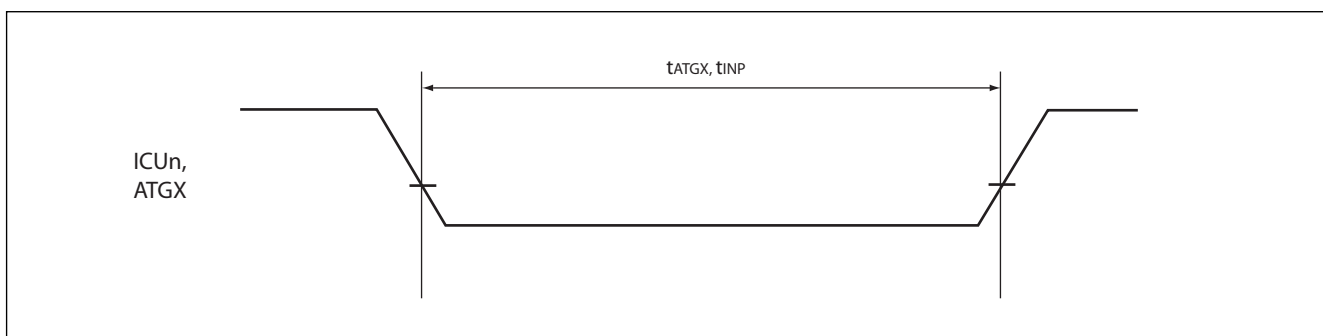

7.7. External Bus AC Timings at $V_{DD35} = 4.5$ to 5.5 V

- Conditions during AC measurements
- All AC tests were measured under the following conditions:
 - $I_{Odrive} = 5$ mA
 - $V_{DD35} = 4.5$ V to 5.5 V, $I_{load} = 5$ mA
 - $V_{SS5} = 0$ V
 - $T_A = -40$ °C to $T_{A(max)}$
 - $C_i = 50$ pF
 - $VOL = 0.2 \times V_{DD35}$
 - $VOH = 0.8 \times V_{DD35}$
 - $EPILR = 0$, $PILR = 1$ (Automotive Level = = worst case)

7.7.1. Basic Timing

($V_{DD35} = 4.5$ V to 5.5 V, $V_{SS5} = AV_{SS5} = 0$ V, $T_A = -40$ °C to $T_{A(max)}$)

Parameter	Symbol	Pin name	Value		Unit
			Min	Max	
SYSCLK	t_{CLCH}	SYSCLK	$1/2 \times t_{CLKT} - 4$	$1/2 \times t_{CLKT} + 5$	ns
	t_{CHCL}		$1/2 \times t_{CLKT} - 5$	$1/2 \times t_{CLKT} + 4$	ns
SYSCLK ↓ to CSXn delay time	t_{CLCSL}	SYSCLK CSXn	—	9	ns
	t_{CLCSH}		—	8	ns
SYSCLK ↑ to CSXn delay time (Addr → CS delay)	t_{CHCSL}		- 2	8	ns
SYSCLK ↓ to ASX delay time	t_{CLASL}	SYSCLK ASX	—	8	ns
	t_{CLASH}		—	7	ns
SYSCLK ↓ to BAAX delay time	t_{CLBAL}	SYSCLK BAAX	—	5	ns
	t_{CLBAH}		- 2	—	ns
SYSCLK ↓ to Address valid delay time	t_{CLAV}	SYSCLK A27 to A0	—	10	ns

Note : t_{CLKT} is the cycle time of the external bus clock.

MB91460Q Series

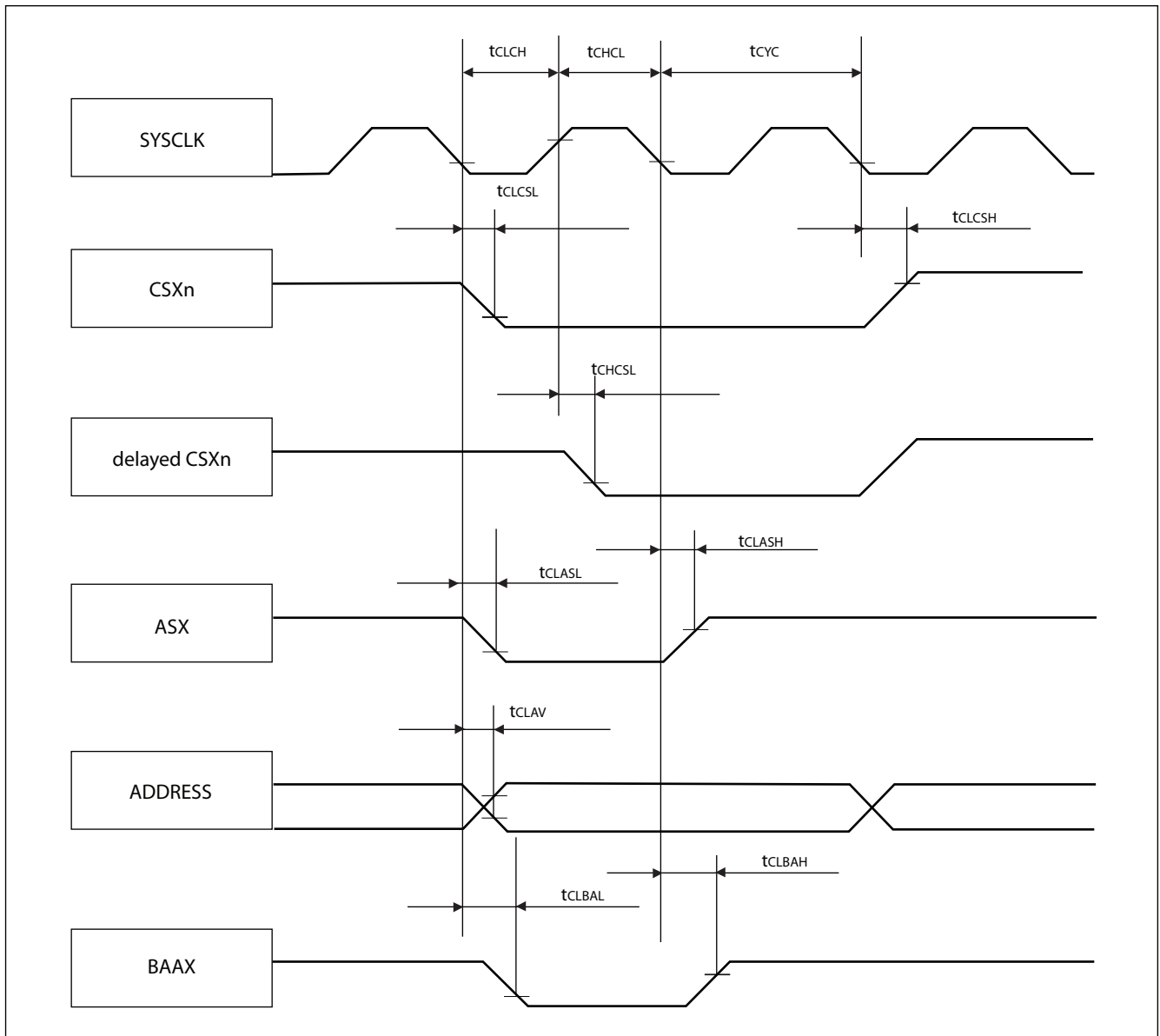

7.7.2. Synchronous/Asynchronous read access with external MCLKI input

($V_{DD35} = 4.5\text{ V to }5.5\text{ V}$, $V_{SS5} = AV_{SS5} = 0\text{ V}$, $T_A = -40\text{ }^\circ\text{C to }T_{A(max)}$)

Parameter	Symbol	Pin name	Value		Unit
			Min	Max	
SYSCLK \uparrow /MCLKI \uparrow to RDX delay time	t_{CHRL}	SYSCLK RDX	-2	7	ns
	t_{CHRH}	MCLKI RDX	10	20	ns
Data valid to RDX \uparrow setup time	t_{DSRH}	RDX D31 to D0	20	—	ns
RDX \uparrow to Data valid hold time (external MCLKI input)	t_{RHDX}	RDX D31 to D0	0	—	ns
Data valid to MCLKI \uparrow setup time	t_{DSCH}	MCLKI D31 to D0	1	—	ns
MCLKI \uparrow to Data valid hold time	t_{CHDX}	MCLKI D31 to D0	3	—	ns
SYSCLK \downarrow to WRXn (as byte enable) delay time	t_{CLWRL}	SYSCLK WRXn	—	9	ns
	t_{CLWRH}		-1	—	ns
SYSCLK \downarrow to CSXn delay time	t_{CLCSL}	SYSCLK CSXn	—	9	ns
	t_{CLCSH}		—	8	ns

Note: The usage of the external feedback from MCLKO to MCLKI is not recommended.

MB91460Q Series

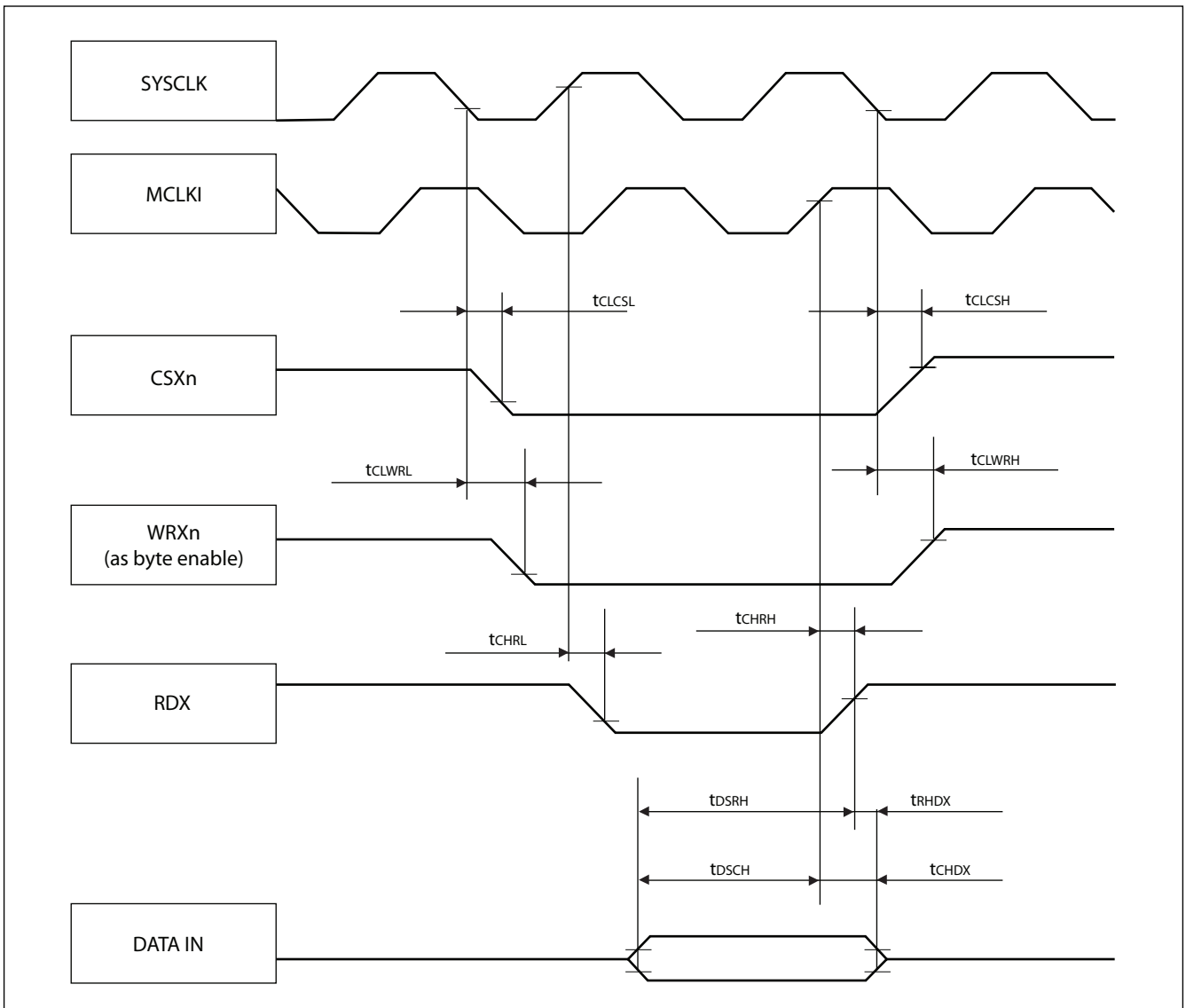

7.7.3. Synchronous/Asynchronous read access with internal MCLKO --> MCLKI feedback

($V_{DD35} = 4.5\text{ V to }5.5\text{ V}$, $V_{SS5} = AV_{SS5} = 0\text{ V}$, $T_A = -40\text{ }^\circ\text{C to }T_{A(max)}$)

Parameter	Symbol	Pin name	Value		Unit
			Min	Max	
SYSCLK \uparrow to RDX delay time	t_{CHRL}	SYSCLK RDX	-2	7	ns
	t_{CHRH}		-2	4	ns
Data valid to RDX \uparrow setup time	t_{DSRH}	RDX D31 to D0	19	—	ns
RDX \uparrow to Data valid hold time (internal MCLKO \rightarrow MCLKI /MCLKI feedback)	t_{RHDX}	RDX D31 to D0	0	—	ns
SYSCLK \downarrow to WRXn (as byte enable) delay time	t_{CLWRL}	SYSCLK WRXn	—	9	ns
	t_{CLWRH}		-1	—	ns
SYSCLK \downarrow to CSXn delay time	t_{CLCSL}	SYSCLK CSXn	—	9	ns
	t_{CLCSH}		—	8	ns

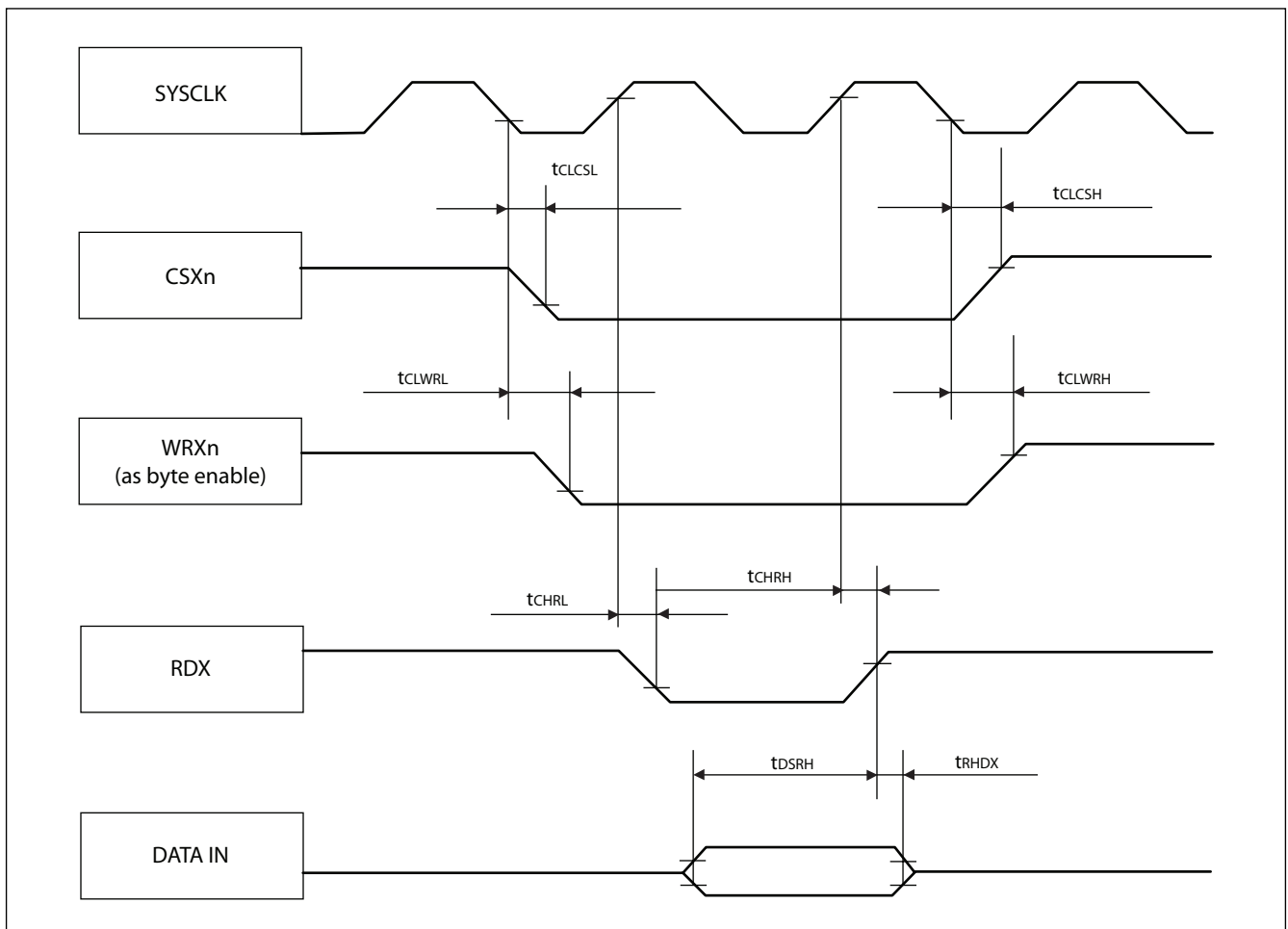

MB91460Q Series

7.7.4. Synchronous write access - byte control type

($V_{DD35} = 4.5\text{ V to }5.5\text{ V}$, $V_{SS5} = AV_{SS5} = 0\text{ V}$, $T_A = -40\text{ }^\circ\text{C to }T_{A(max)}$)

Parameter	Symbol	Pin name	Value		Unit
			Min	Max	
SYSCLK ↓ to WEX delay time	t_{CLWL}	SYSCLK WEX	—	8	ns
	t_{CLWH}		- 2	—	ns
Data valid to WEX ↓ setup time	t_{DSWL}	WEX D31 to D0	- 5	—	ns
WEX ↑ to Data valid hold time	t_{WHDH}	WEX D31 to D0	$t_{CLKT} - 10$	—	ns
SYSCLK ↓ to WRXn (as byte enable) delay time	t_{CLWRL}	SYSCLK WRXn	—	9	ns
	t_{CLWRH}		- 1	—	ns
SYSCLK ↓ to CSXn delay time	t_{CLCSL}	SYSCLK CSXn	—	9	ns
	t_{CLCSH}		—	8	ns

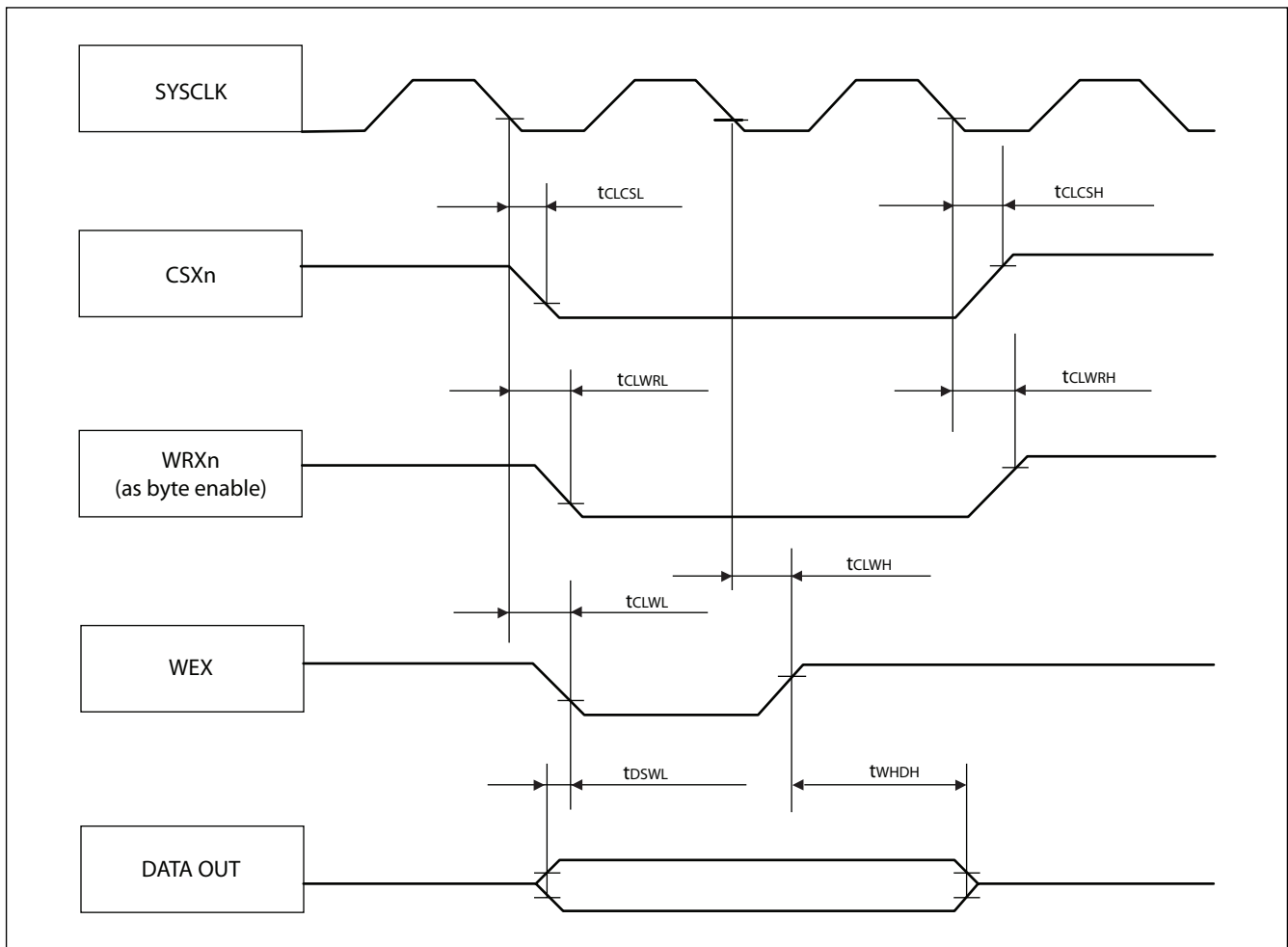

7.7.5. Synchronous write access - no byte control type

($V_{DD35} = 4.5\text{ V to }5.5\text{ V}$, $V_{SS5} = AV_{SS5} = 0\text{ V}$, $T_A = -40\text{ }^{\circ}\text{C to }T_{A(max)}$)

Parameter	Symbol	Pin name	Value		Unit
			Min	Max	
SYSCLK ↓ to WRXn delay time	t_{CLWRL}	SYSCLK WRXn	—	9	ns
	t_{CLWRH}		-1	—	ns
Data valid to WRXn ↓ setup time	t_{DSWRL}	WRXn D31 to D0	-6	—	ns
WRXn ↑ to Data valid hold time	t_{WRHDH}	WRXn D31 to D0	$t_{CLKT} - 10$	—	ns
SYSCLK ↓ to CSXn delay time	t_{CLCSL}	SYSCLK CSXn	—	9	ns
	t_{CLCSH}		—	8	ns

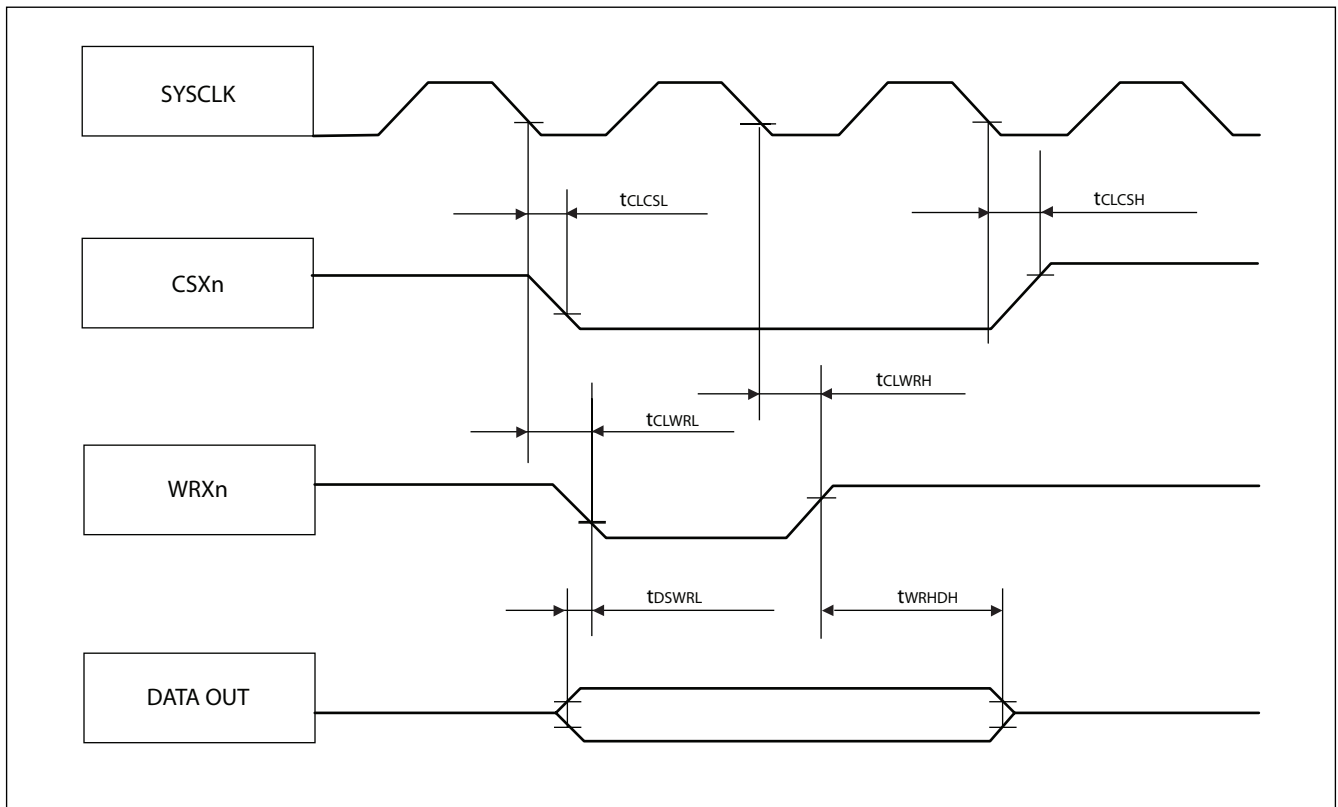

MB91460Q Series

7.7.6. Asynchronous write access - byte control type

($V_{DD35} = 4.5\text{ V to }5.5\text{ V}$, $V_{SS5} = AV_{SS5} = 0\text{ V}$, $T_A = -40\text{ }^{\circ}\text{C to }T_{A(max)}$)

Parameter	Symbol	Pin name	Value		Unit
			Min	Max	
WEX ↓ to WEX ↑ pulse width	t_{WLWH}	WEX	$t_{CLKT} - 6$	—	ns
Data valid to WEX ↓ setup time	t_{DSWL}	WEX D31 to D0	$1/2 \times t_{CLKT} - 9$	—	ns
WEX ↑ to Data valid hold time	t_{WHDH}	WEX D31 to D0	$1/2 \times t_{CLKT} - 7$	—	ns
WEX to WRXn delay time	t_{WRLWL}	WEX WRXn	—	$1/2 \times t_{CLKT} + 2$	ns
	t_{WHWRH}	WEX WRXn	$1/2 \times t_{CLKT} - 1$	—	ns
WEX to CSXn delay time	t_{CLWL}	WEX CSXn	—	$1/2 \times t_{CLKT} - 1$	ns
	t_{WHCH}	WEX CSXn	$1/2 \times t_{CLKT} + 1$	—	ns

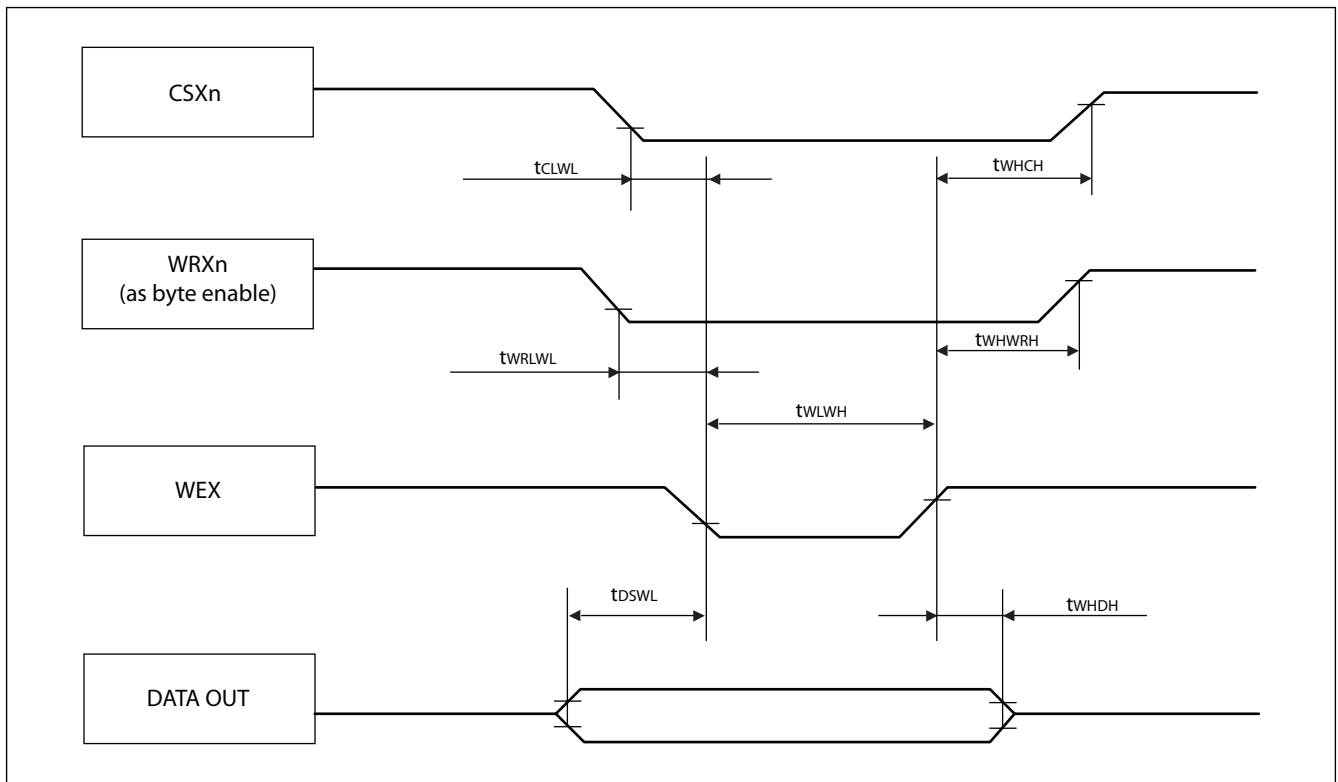

7.7.7. Asynchronous write access - no byte control type

($V_{DD35} = 4.5\text{ V to }5.5\text{ V}$, $V_{SS5} = AV_{SS5} = 0\text{ V}$, $T_A = -40\text{ }^\circ\text{C to }T_{A(max)}$)

Parameter	Symbol	Pin name	Value		Unit
			Min	Max	
WRXn ↓ to WRXn ↑ pulse width	t_{WRLWRH}	WRXn	$t_{CLKT} - 6$	—	ns
Data valid to WRXn ↓ setup time	t_{DSWRL}	WRXn D31 to D0	$1/2 \times t_{CLKT} - 9$	—	ns
WRXn ↑ to Data valid hold time	t_{WRHDL}	WRXn D31 to D0	$1/2 \times t_{CLKT} - 7$	—	ns
WRXn to CSXn delay time	t_{CLWRL}	WRXn CSXn	—	$1/2 \times t_{CLKT} - 1$	ns
	t_{WRHCH}		$1/2 \times t_{CLKT} + 1$	—	ns

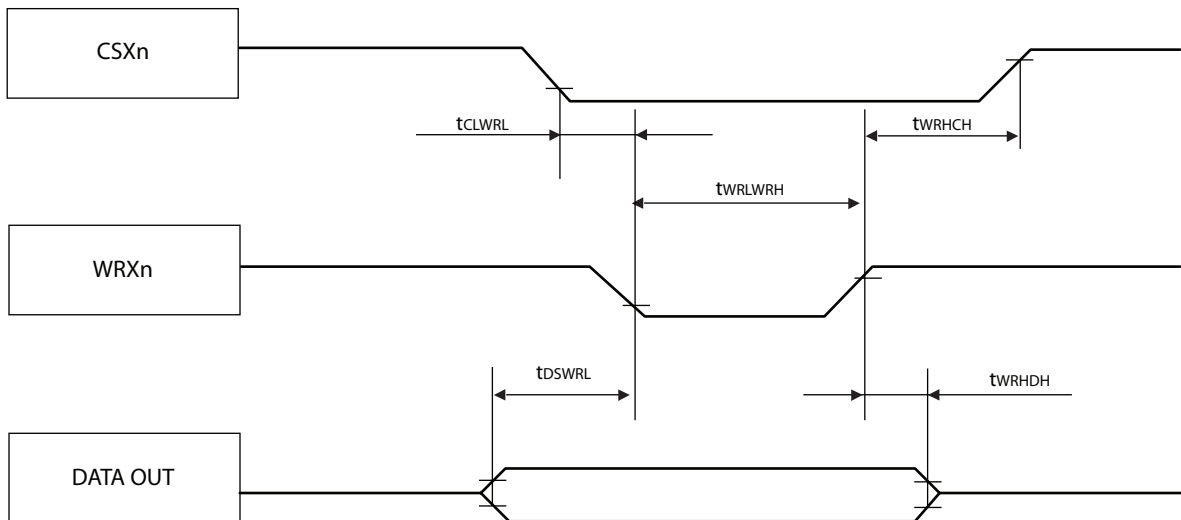

MB91460Q Series

7.7.8. RDY waitcycle insertion

($V_{DD35} = 4.5 \text{ V to } 5.5 \text{ V}$, $V_{SS5} = AV_{SS5} = 0 \text{ V}$, $T_A = -40 \text{ }^\circ\text{C to } T_{A(max)}$)

Parameter	Symbol	Pin name	Value		Unit
			Min	Max	
RDY setup time	t_{RDYS}	SYSCLK RDY	19	—	ns
RDY hold time	t_{RDYH}	SYSCLK RDY	0	—	ns

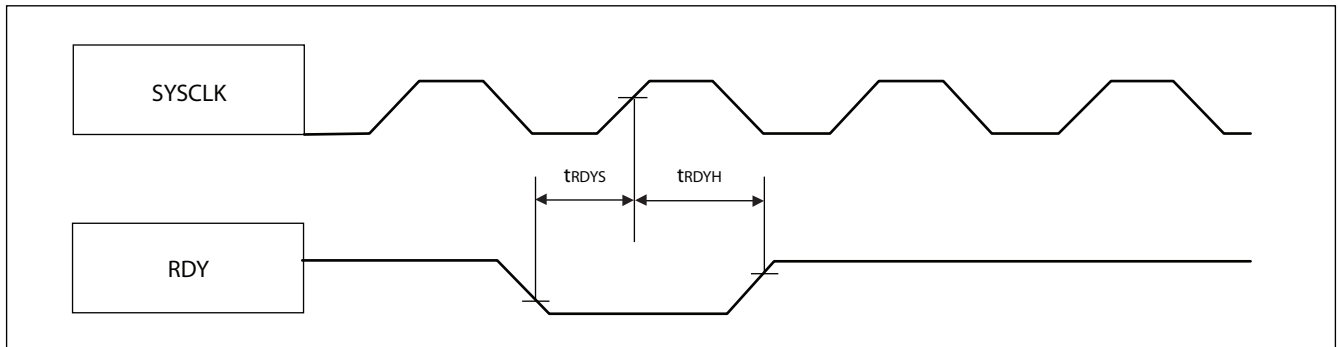

7.7.9. Bus hold timing

($V_{DD35} = 4.5\text{ V to }5.5\text{ V}$, $V_{SS5} = AV_{SS5} = 0\text{ V}$, $T_A = -40\text{ }^\circ\text{C to }T_{A(max)}$)

Parameter	Symbol	Pin name	Value		Unit
			Min	Max	
SYSCLK ↓ to BGRNTX delay time	t_{CLBGL}	SYSCLK BGRNTX	—	5	ns
	t_{CLBGH}		—	5	ns
Bus HIZ to BGRNTX ↓	t_{AXBGL}	BGRNTX MCLK* A0 to An RDX, ASX WRXn, WEX CSXn, BAAX	$t_{CLKT} + 2$	—	ns
BGRNTX ↑ to Bus drive	t_{BGHAV}		$t_{CLKT} + 1$	—	ns

Note : BRQ must be kept High until the bus is granted (this is acknowledged by the falling edge of BGRNTX).
It must be kept High as long as the bus shall be hold.
After releasing the bus (BRQ set to Low) this is acknowledged by the rising edge of BGRNTX.

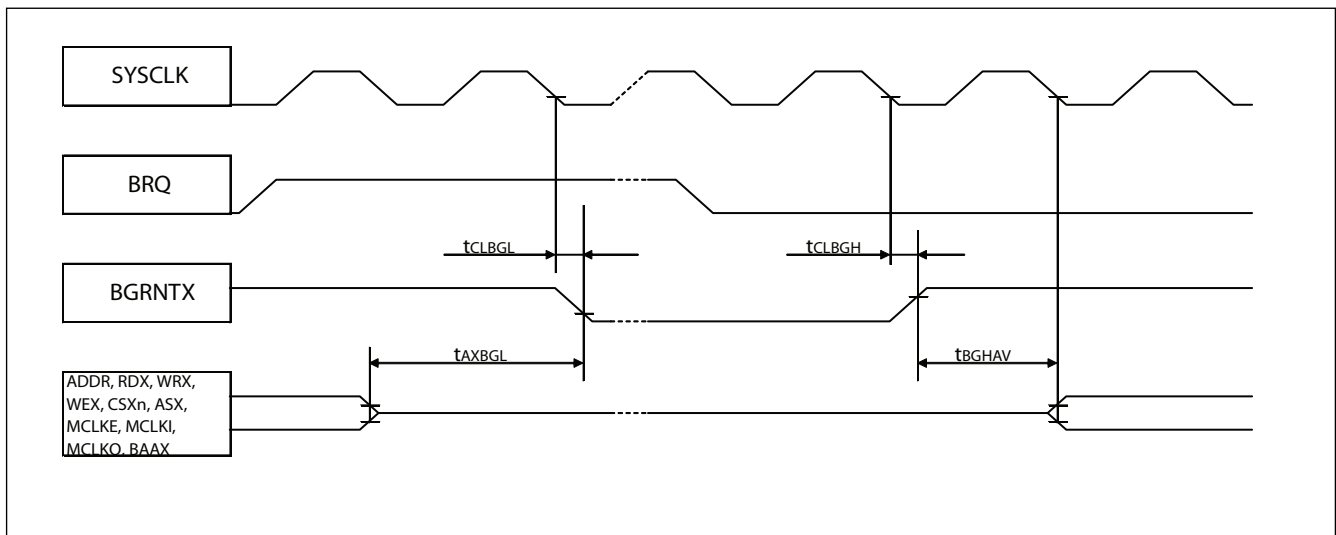

MB91460Q Series

7.7.10. Clock relationships

($V_{DD35} = 4.5 \text{ V to } 5.5 \text{ V}$, $V_{SS5} = AV_{SS5} = 0 \text{ V}$, $T_A = -40 \text{ }^\circ\text{C to } T_{A(max)}$)

Parameter	Symbol	Pin name	Value		Unit
			Min	Max	
SYSCLK to MCLKO	t_{CSMHM}	SYSCLK	1	5	ns
	t_{CSLML}	MCLKO	0	2	ns
MCLKO ↓ to MCLKE (in sleep mode)	t_{CLML}	MCLKO	—	5	ns
	t_{CLMH}	MCLKE	-3	—	ns

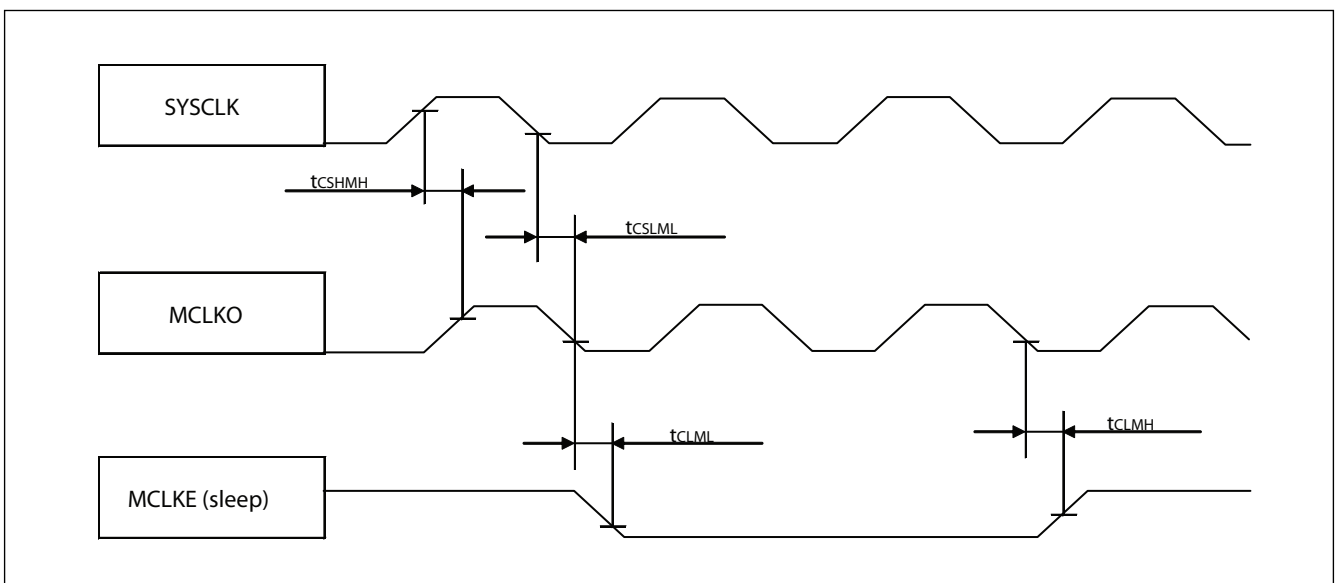

7.7.11. DMA transfer

($V_{DD35} = 4.5\text{ V to }5.5\text{ V}$, $V_{SS5} = AV_{SS5} = 0\text{ V}$, $T_A = -40\text{ }^\circ\text{C to }T_{A(max)}$)

Parameter	Symbol	Pin name	Value		Unit
			Min	Max	
SYSCLK ↓ to DACKX delay time	t_{CLDAL}	SYSCLK	—	8	ns
	t_{CLDAH}	DACKXn	—	8	ns
SYSCLK ↓ to DEOP delay time	t_{CLDEL}	SYSCLK	—	7	ns
	t_{CLDEH}	DEOPn	—	9	ns
SYSCLK ↑ to DACKX delay time (ADDR → CS delayed)	t_{CHDAL}	SYSCLK DACKXn	- 1	8	ns
SYSCLK ↑ to DEOP delay time (ADDR → CS delayed)	t_{CHDEL}	SYSCLK DEOPn	- 1	8	ns
DREQ setup time	t_{DRQS}	SYSCLK DREQn	19	—	ns
DREQ hold time	t_{DRQH}	SYSCLK DREQn	0	—	ns
DEOTXn setup time	t_{DTXS}	SYSCLK DEOTXn	20	—	ns
DEOTXn hold time	t_{DTXH}	SYSCLK DEOTXn	0	—	ns

Note : DREQ and DEOTX must be applied for at least $5 \times t_{CLKT}$ to ensure that they are really sampled and evaluated.
Under best case conditions (DMA not busy) only setup and hold times are required.

MB91460Q Series

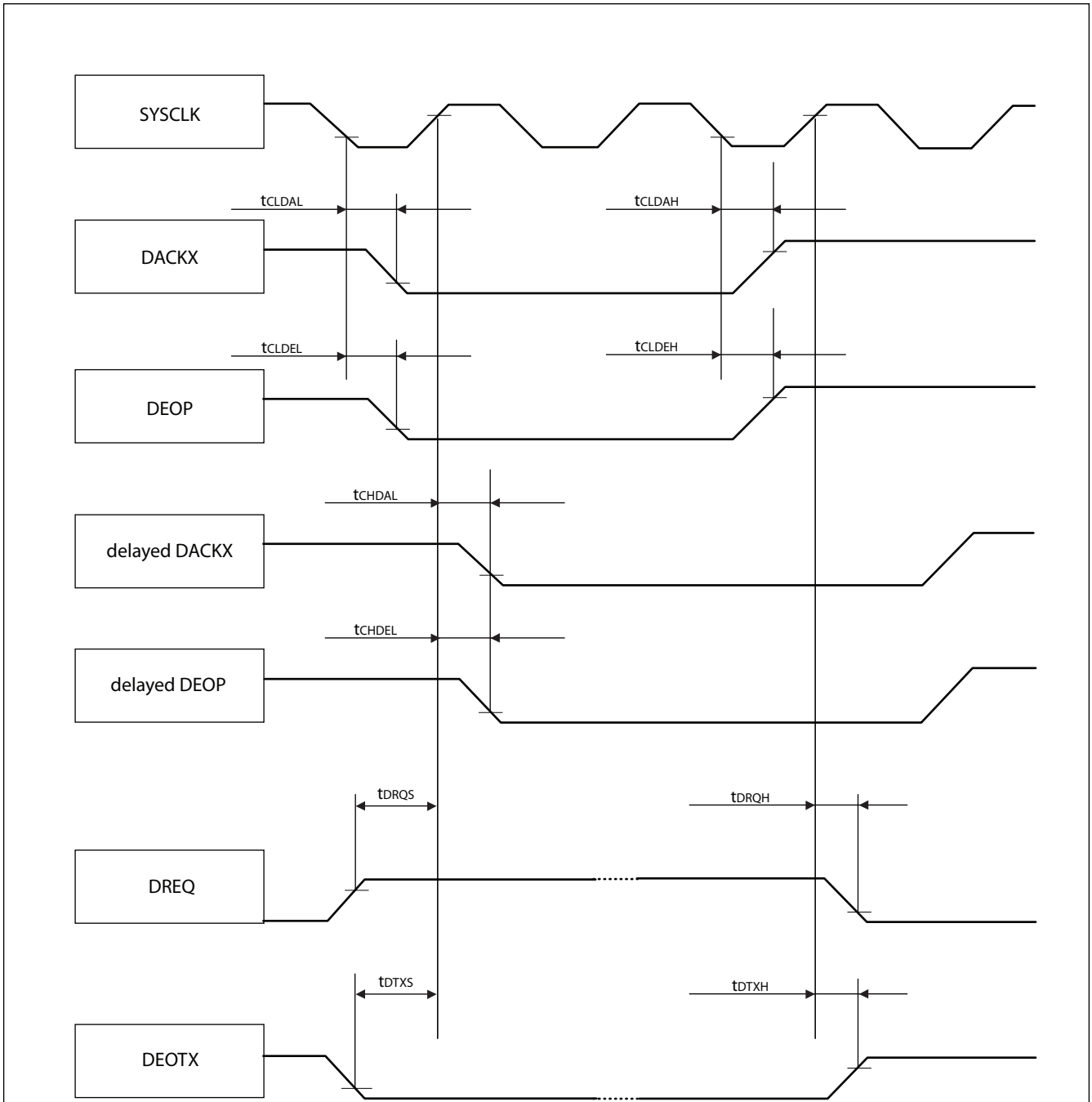

7.7.12. DMA flyby transfer

($V_{DD35} = 4.5\text{ V to }5.5\text{ V}$, $V_{SS5} = AV_{SS5} = 0\text{ V}$, $T_A = -40\text{ }^\circ\text{C to }T_{A(max)}$)

Parameter	Symbol	Pin name	Value		Unit
			Min	Max	
SYSCLK \uparrow to IORDX delay time	t_{CHIRL}	SYSCLK IORDX	- 2	8	ns
	t_{CHIRH}		0	4	ns
SYSCLK \uparrow to IOWRX delay time	t_{CHIWL}	SYSCLK IOWRX	- 2	8	ns
	t_{CHIWH}		- 1	3	ns

:

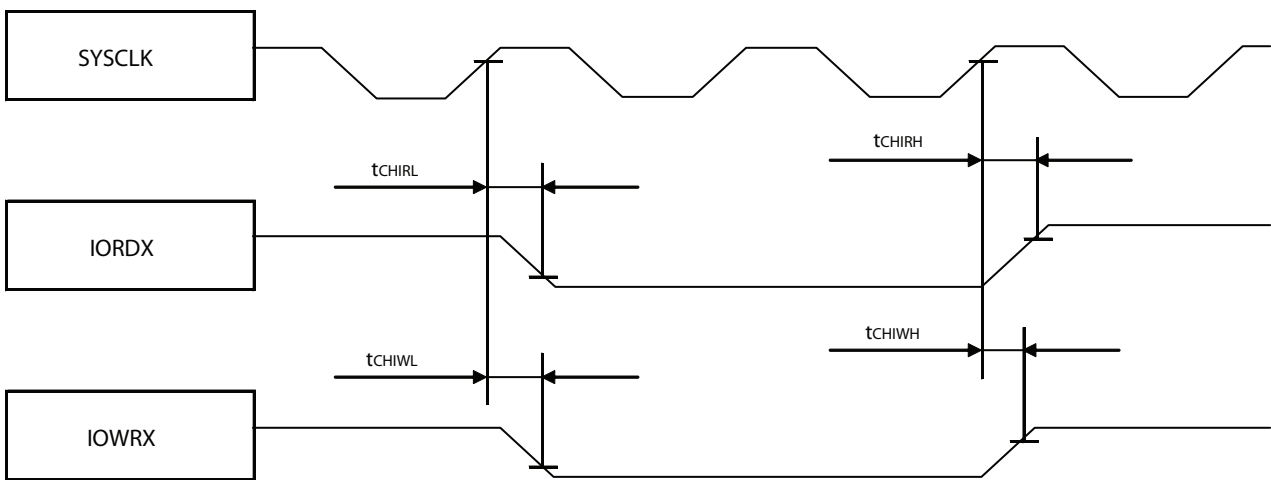

MB91460Q Series

7.8. External Bus AC Timings at $V_{DD35} = 3.0$ to 4.5 V

- Conditions during AC measurements

All AC tests were measured under the following conditions:

- $I_{Odrive} = 5$ mA
- $V_{DD35} = 3.0$ V to 4.5 V, $I_{load} = 3$ mA
- $V_{SS5} = 0$ V
- $T_A = -40$ °C to $T_{A(max)}$
- $C_i = 50$ pF
- $VOL = 0.2 \times V_{DD35}$
- $VOH = 0.8 \times V_{DD35}$
- $EPILR = 0$, $PILR = 1$ (Automotive Level = = worst case)

7.8.1. Basic Timing

($V_{DD35} = 3.0$ V to 4.5 V, $V_{SS5} = AV_{SS5} = 0$ V, $T_A = -40$ °C to $T_{A(max)}$)

Parameter	Symbol	Pin name	Value		Unit
			Min	Max	
SYSCLK	t_{CLCH}	SYSCLK	$1/2 \times t_{CLKT} - 1$	$1/2 \times t_{CLKT} + 3$	ns
	t_{CHCL}		$1/2 \times t_{CLKT} - 3$	$1/2 \times t_{CLKT} + 1$	ns
SYSCLK ↓ to CSXn delay time	t_{CLCSL}	SYSCLK CSXn	—	9	ns
	t_{CLCSH}		—	7	ns
SYSCLK ↑ to CSXn delay time (Addr → CS delay)	t_{CHCSL}		- 1	4	ns
SYSCLK ↓ to ASX delay time	t_{CLASL}	SYSCLK ASX	—	5	ns
	t_{CLASH}		—	6	ns
SYSCLK ↓ to BAAX delay time	t_{CLBAL}	SYSCLK BAAX	—	6	ns
	t_{CLBAH}		0	—	ns
SYSCLK ↓ to Address valid delay time	t_{CLAV}	SYSCLK A27 to A0	—	13	ns

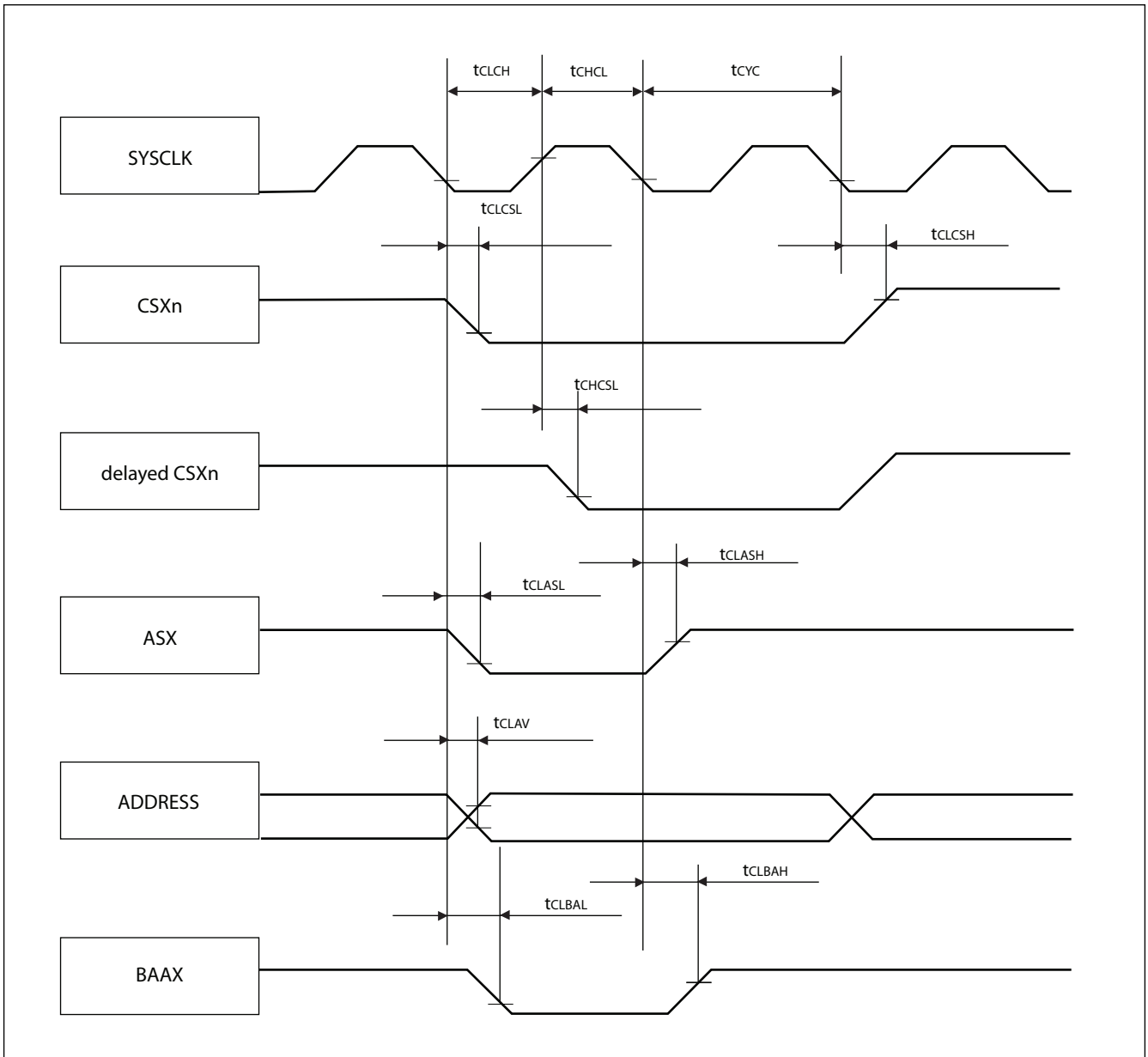

MB91460Q Series

7.8.2. Synchronous/Asynchronous read access with external MCLKI input

($V_{DD35} = 3.0\text{ V to }4.5\text{ V}$, $V_{SS5} = AV_{SS5} = 0\text{ V}$, $T_A = -40\text{ }^{\circ}\text{C to }T_{A(max)}$)

Parameter	Symbol	Pin name	Value		Unit
			Min	Max	
SYSCLK \uparrow /MCLKI \uparrow to RDX delay time	t_{CHRL}	SYSCLK RDX	- 1	3	ns
	t_{CHRH}	MCLKI RDX	11	25	ns
Data valid to RDX \uparrow setup time	t_{DSRH}	RDX D31 to D0	25	—	ns
RDX \uparrow to Data valid hold time (external MCLKI input)	t_{RHDX}	RDX D31 to D0	0	—	ns
Data valid to MCLKI \uparrow setup time	t_{DSCH}	MCLKI D31 to D0	1	—	ns
MCLKI \uparrow to Data valid hold time	t_{CHDX}	MCLKI D31 to D0	3	—	ns
SYSCLK \downarrow to WRXn (as byte enable) delay time	t_{CLWRL}	SYSCLK WRXn	—	5	ns
	t_{CLWRH}		- 1	—	ns
SYSCLK \downarrow to CSXn delay time	t_{CLCSL}	SYSCLK CSXn	—	5	ns
	t_{CLCSH}		—	6	ns

Note: The usage of the external feedback from MCLKO to MCLKI is not recommended.

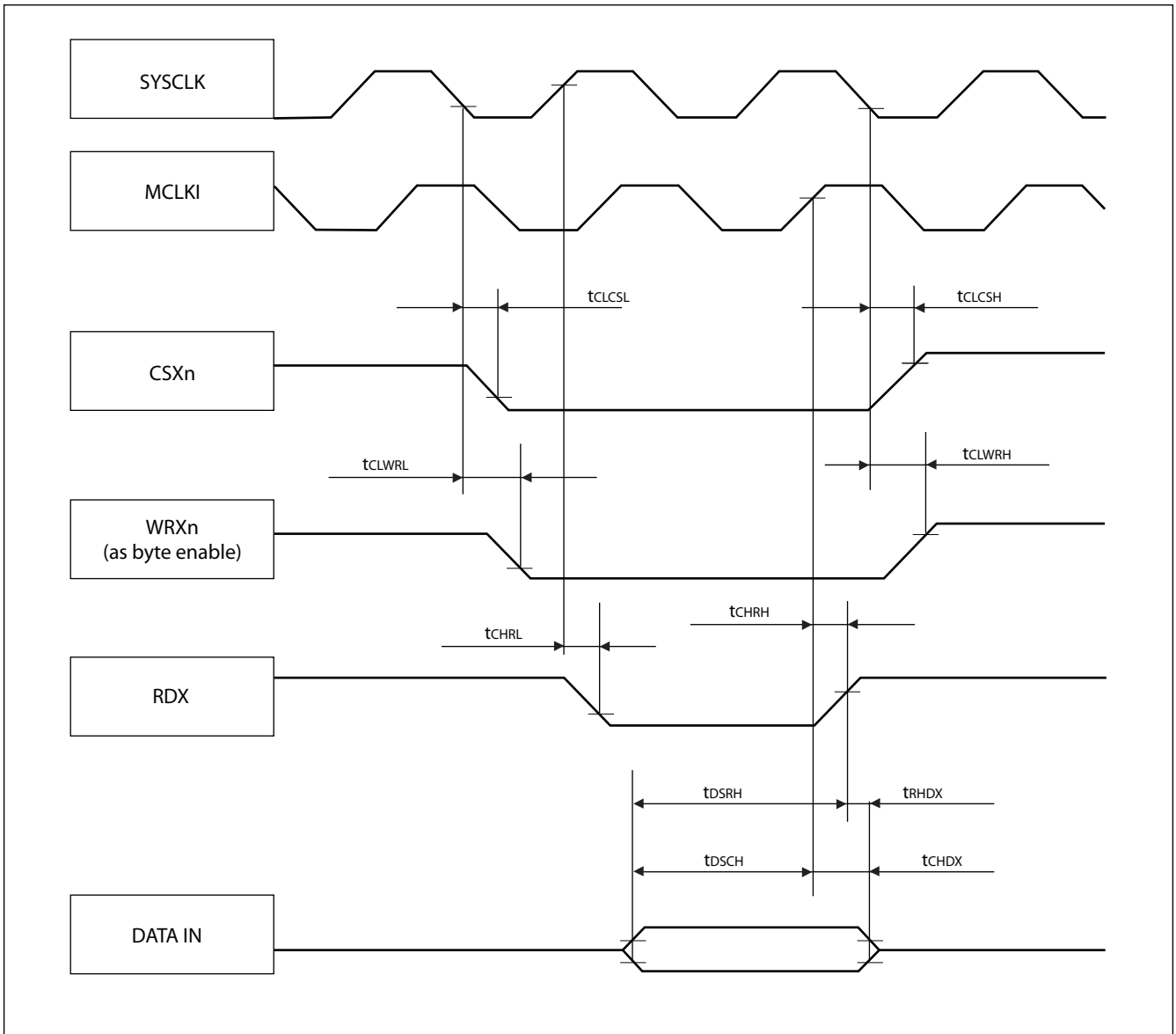

MB91460Q Series

7.8.3. Synchronous/Asynchronous read access with internal MCLKO --> MCLKI feedback

($V_{DD35} = 3.0\text{ V to }4.5\text{ V}$, $V_{SS5} = AV_{SS5} = 0\text{ V}$, $T_A = -40\text{ }^\circ\text{C to }T_{A(max)}$)

Parameter	Symbol	Pin name	Value		Unit
			Min	Max	
SYSCLK \uparrow to RDX delay time	t_{CHRL}	SYSCLK RDX	-1	3	ns
	t_{CHRH}		-2	4	ns
Data valid to RDX \uparrow setup time	t_{DSRH}	RDX D31 to D0	25	—	ns
RDX \uparrow to Data valid hold time (internal MCLKO \rightarrow MCLKI / /MCLKI feedback)	t_{RHDX}	RDX D31 to D0	0	—	ns
SYSCLK \downarrow to WRXn (as byte enable) delay time	t_{CLWRL}	SYSCLK WRXn	—	5	ns
	t_{CLWRH}		-1	—	ns
SYSCLK \downarrow to CSXn delay time	t_{CLCSL}	SYSCLK CSXn	—	5	ns
	t_{CLCSH}		—	6	ns

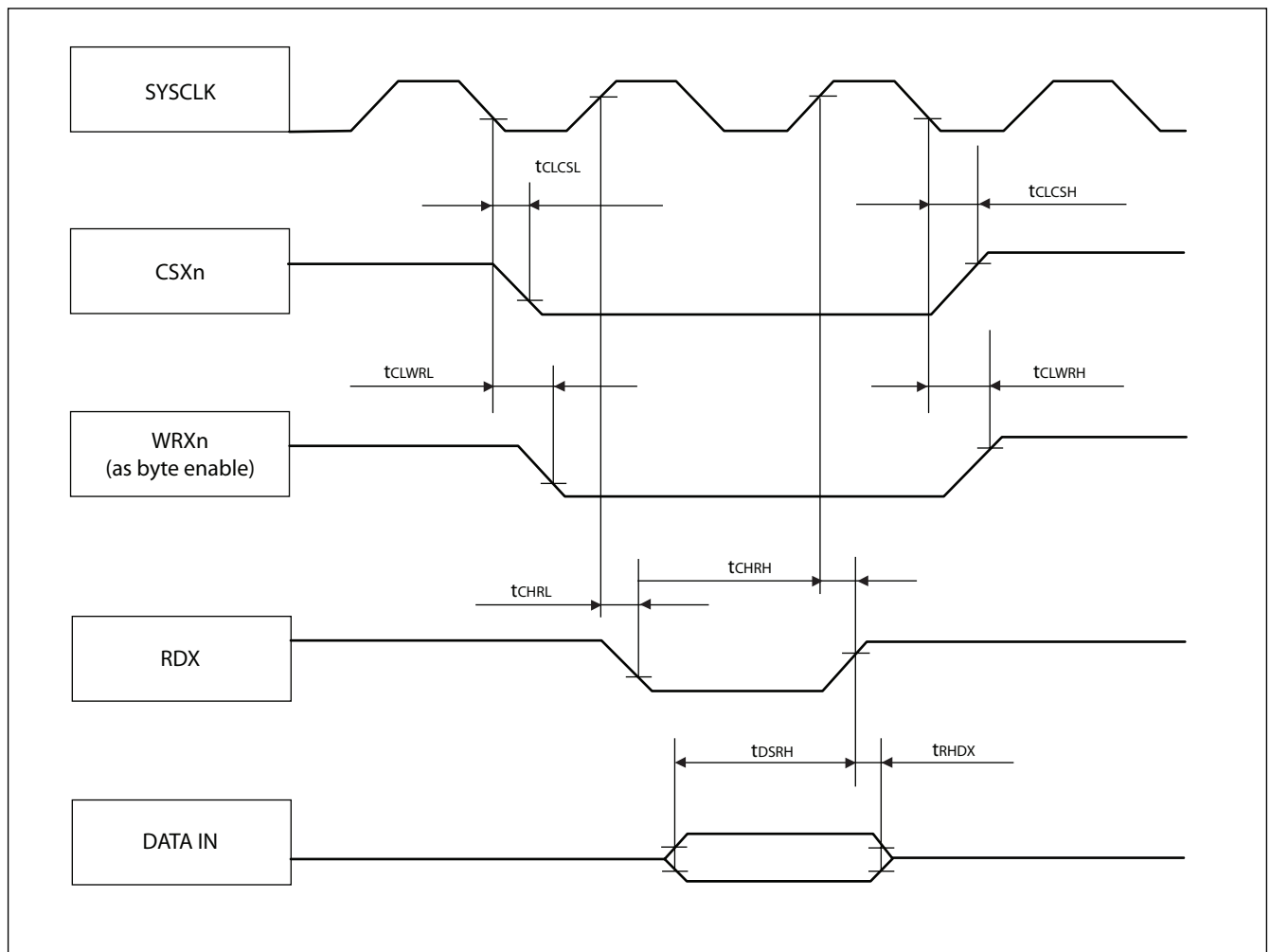

7.8.4. Synchronous write access - byte control type

($V_{DD35} = 3.0\text{ V to }4.5\text{ V}$, $V_{SS5} = AV_{SS5} = 0\text{ V}$, $T_A = -40\text{ }^\circ\text{C to }T_{A(max)}$)

Parameter	Symbol	Pin name	Value		Unit
			Min	Max	
SYSCLK ↓ to WEX delay time	t_{CLWL}	SYSCLK WEX	—	5	ns
	t_{CLWH}		- 1	—	ns
Data valid to WEX ↓ setup time	t_{DSWL}	WEX D31 to D0	- 11	—	ns
WEX ↑ to Data valid hold time	t_{WHDH}	WEX D31 to D0	$t_{CLKT} - 13$	—	ns
SYSCLK ↓ to WRXn (as byte enable) delay time	t_{CLWRL}	SYSCLK WRXn	—	5	ns
	t_{CLWRH}		- 1	—	ns
SYSCLK ↓ to CSXn delay time	t_{CLCSL}	SYSCLK CSXn	—	5	ns
	t_{CLCSH}		—	6	ns

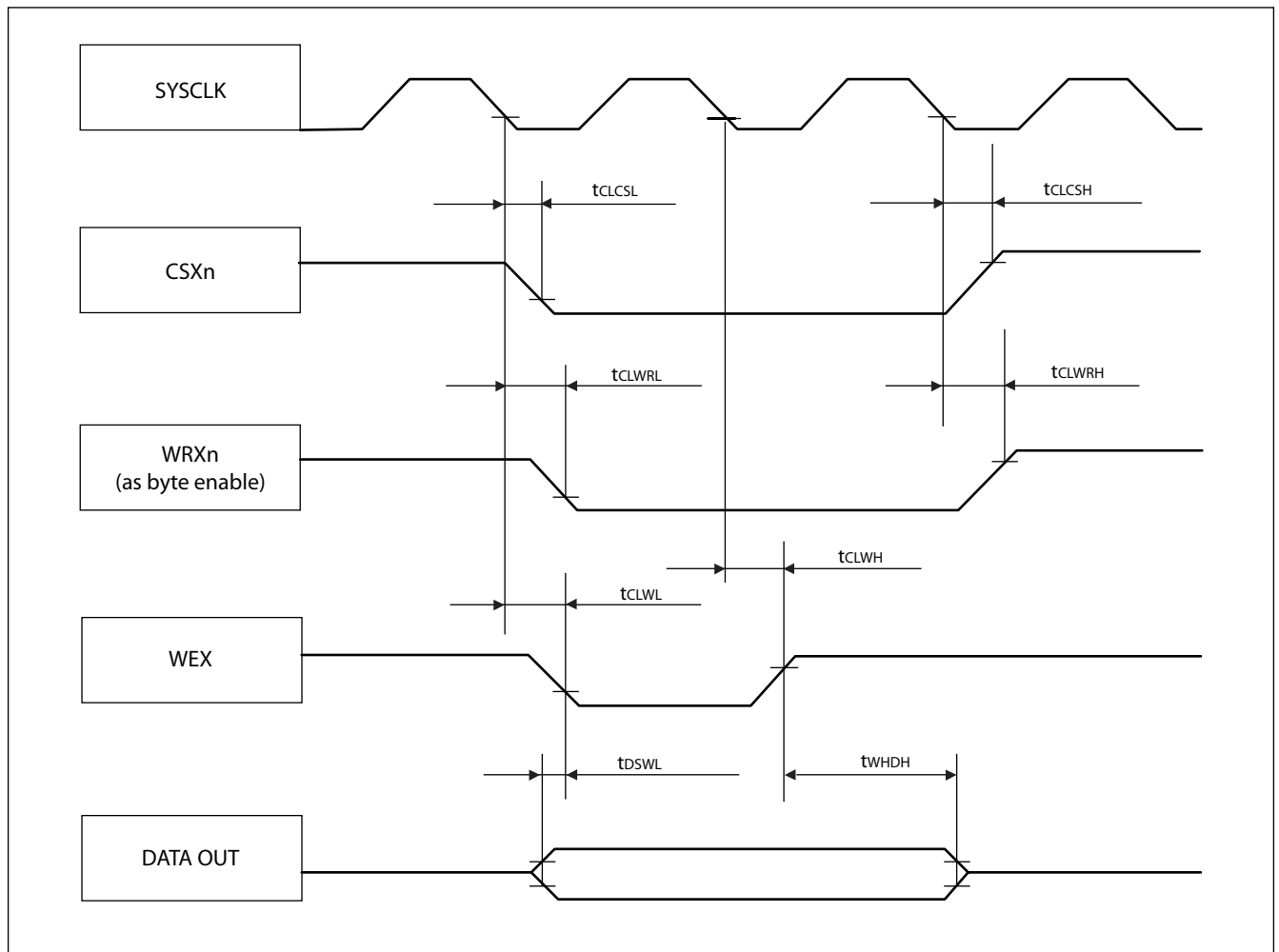

MB91460Q Series

7.8.5. Synchronous write access - no byte control type

($V_{DD35} = 3.0\text{ V to }4.5\text{ V}$, $V_{SS5} = AV_{SS5} = 0\text{ V}$, $T_A = -40\text{ }^\circ\text{C to }T_{A(max)}$)

Parameter	Symbol	Pin name	Value		Unit
			Min	Max	
SYSCLK ↓ to WRXn delay time	t_{CLWRL}	SYSCLK WRXn	—	5	ns
	t_{CLWRH}		- 1	—	ns
Data valid to WRXn ↓ setup time	t_{DSWRL}	WRXn D31 to D0	- 11	—	ns
WRXn ↑ to Data valid hold time	t_{WRHDH}	WRXn D31 to D0	$t_{CLKT} - 13$	—	ns
SYSCLK ↓ to CSXn delay time	t_{CLCSL}	SYSCLK CSXn	—	5	ns
	t_{CLCSH}		—	6	ns

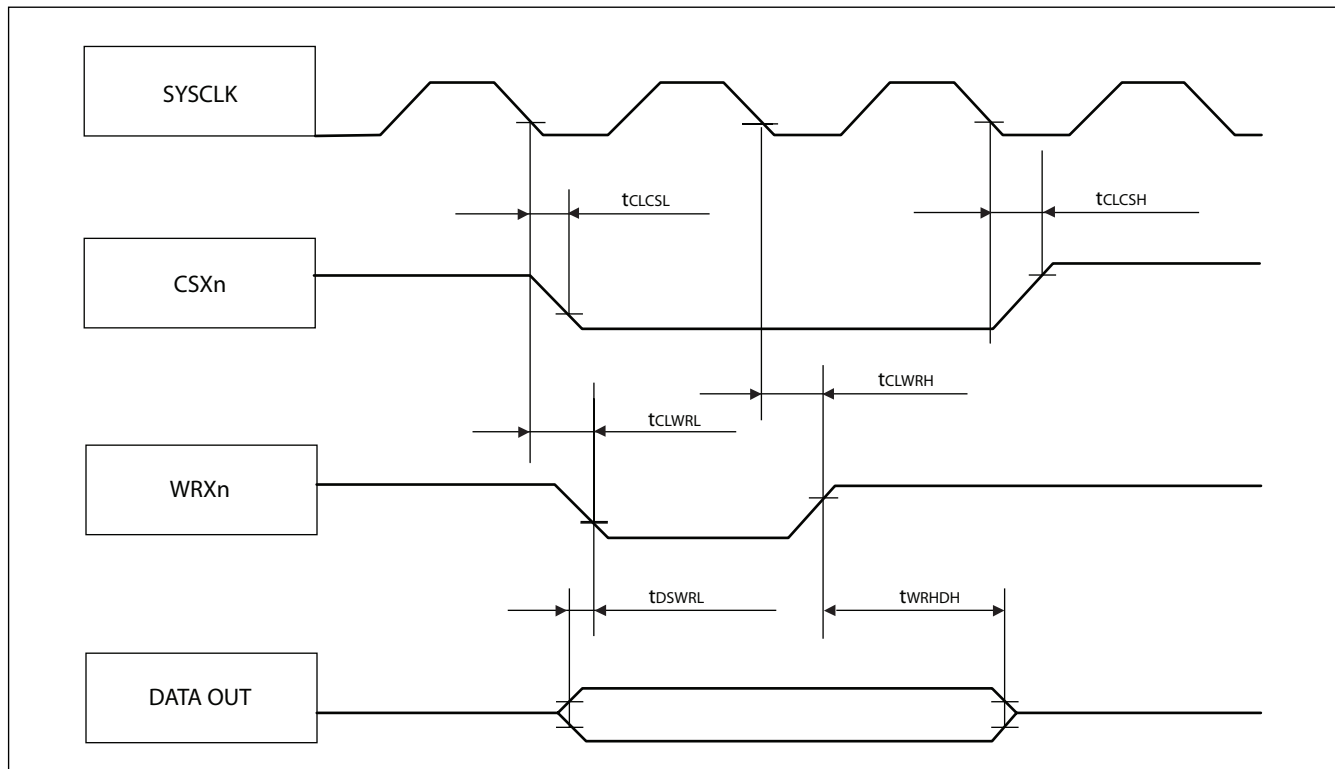

7.8.6. Asynchronous write access - byte control type

($V_{DD35} = 3.0\text{ V to }4.5\text{ V}$, $V_{SS5} = AV_{SS5} = 0\text{ V}$, $T_A = -40\text{ }^\circ\text{C to }T_{A(max)}$)

Parameter	Symbol	Pin name	Value		Unit
			Min	Max	
WEX ↓ to WEX ↑ pulse width	t_{WLWH}	WEX	$t_{CLKT} - 4$	—	ns
Data valid to WEX ↓ setup time	t_{DSWL}	WEX D31 to D0	$1/2 \times t_{CLKT} - 12$	—	ns
WEX ↑ to Data valid hold time	t_{WHDH}	WEX D31 to D0	$1/2 \times t_{CLKT} - 11$	—	ns
WEX to WRXn delay time	t_{WRLWL}	WEX WRXn	—	$1/2 \times t_{CLKT} + 1$	ns
	t_{WHWRH}		$1/2 \times t_{CLKT} - 1$	—	ns
WEX to CSXn delay time	t_{CLWL}	WEX CSXn	—	$1/2 \times t_{CLKT} - 1$	ns
	t_{WHCH}		$1/2 \times t_{CLKT} + 1$	—	ns

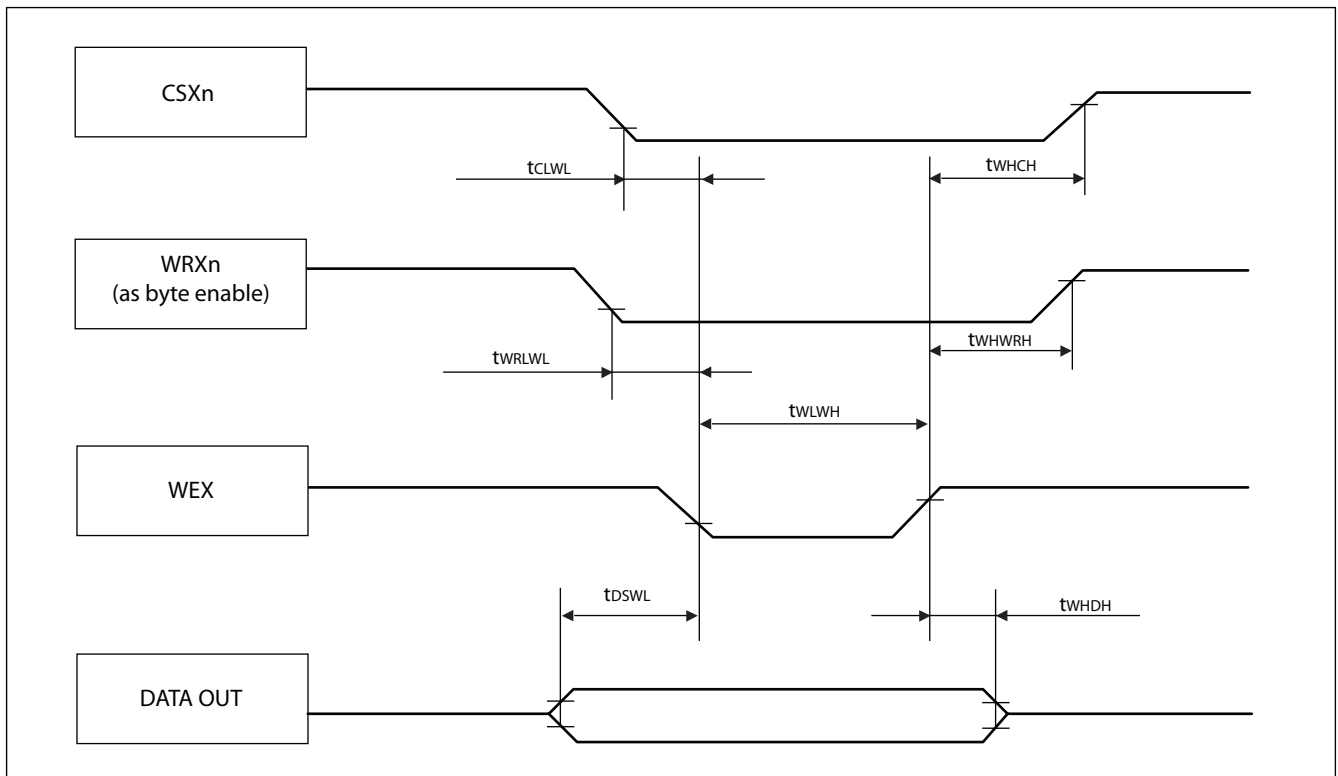

MB91460Q Series

7.8.7. Asynchronous write access - no byte control type

($V_{DD35} = 3.0\text{ V to }4.5\text{ V}$, $V_{SS5} = AV_{SS5} = 0\text{ V}$, $T_A = -40\text{ }^\circ\text{C to }T_{A(max)}$)

Parameter	Symbol	Pin name	Value		Unit
			Min	Max	
WRXn ↓ to WRXn ↑ pulse width	t_{WRLWRH}	WRXn	$t_{CLKT} - 3$	—	ns
Data valid to WRXn ↓ setup time	t_{DSWRL}	WRXn D31 to D0	$1/2 \times t_{CLKT} - 12$	—	ns
WRXn ↑ to Data valid hold time	t_{WRHDH}	WRXn D31 to D0	$1/2 \times t_{CLKT} - 11$	—	ns
WRXn to CSXn delay time	t_{CLWRL}	WRXn CSXn	—	$1/2 \times t_{CLKT} - 1$	ns
	t_{WRHCH}		$1/2 \times t_{CLKT} + 1$	—	ns

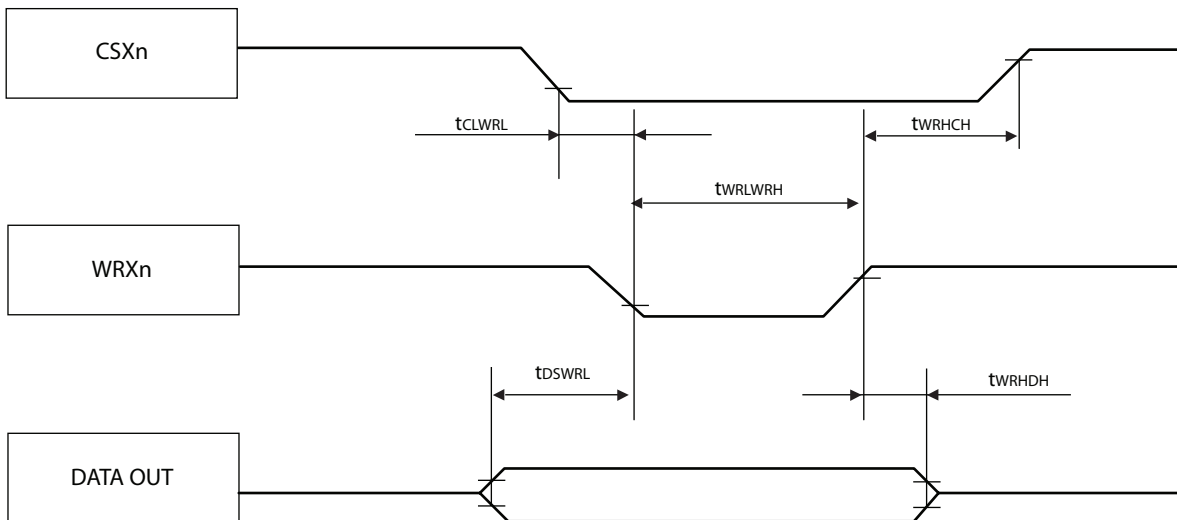

7.8.8. RDY waitcycle insertion

($V_{DD35} = 3.0\text{ V to }4.5\text{ V}$, $V_{SS5} = AV_{SS5} = 0\text{ V}$, $T_A = -40\text{ }^\circ\text{C to }T_{A(max)}$)

Parameter	Symbol	Pin name	Value		Unit
			Min	Max	
RDY setup time	t_{RDYS}	SYSCLK RDY	24	—	ns
RDY hold time	t_{RDYH}	SYSCLK RDY	0	—	ns

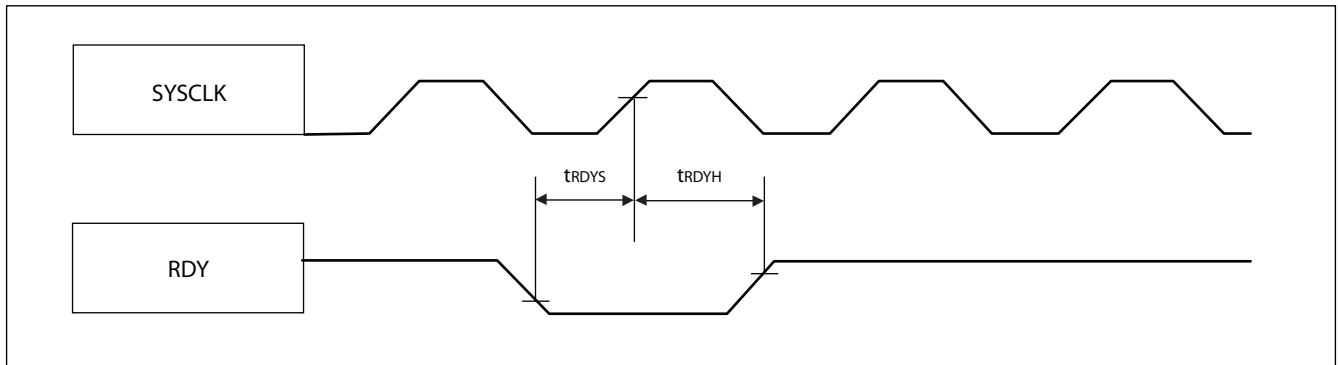

MB91460Q Series

7.8.9. Bus hold timing

($V_{DD35} = 3.0\text{ V to }4.5\text{ V}$, $V_{SS5} = AV_{SS5} = 0\text{ V}$, $T_A = -40\text{ }^{\circ}\text{C to }T_{A(max)}$)

Parameter	Symbol	Pin name	Value		Unit
			Min	Max	
SYSCLK ↓ to BGRNTX delay time	t_{CLBGL}	SYSCLK	—	5	ns
	t_{CLBGH}	BGRNTX	—	6	ns
Bus HIZ to BGRNTX ↓	t_{AXBGL}	BGRNTX	$t_{CLKT} + 2$	—	ns
BGRNTX ↑ to Bus drive	t_{BGHAV}	MCLK* A0 to An RDX, ASX WRXn, WEX CSXn, BAAX	$t_{CLKT} - 2$	—	ns

Note : BRQ must be kept High until the bus is granted (this is acknowledged by the falling edge of BGRNTX).
It must be kept High as long as the bus shall be hold.
After releasing the bus (BRQ set to Low) this is acknowledged by the rising edge of BGRNTX.

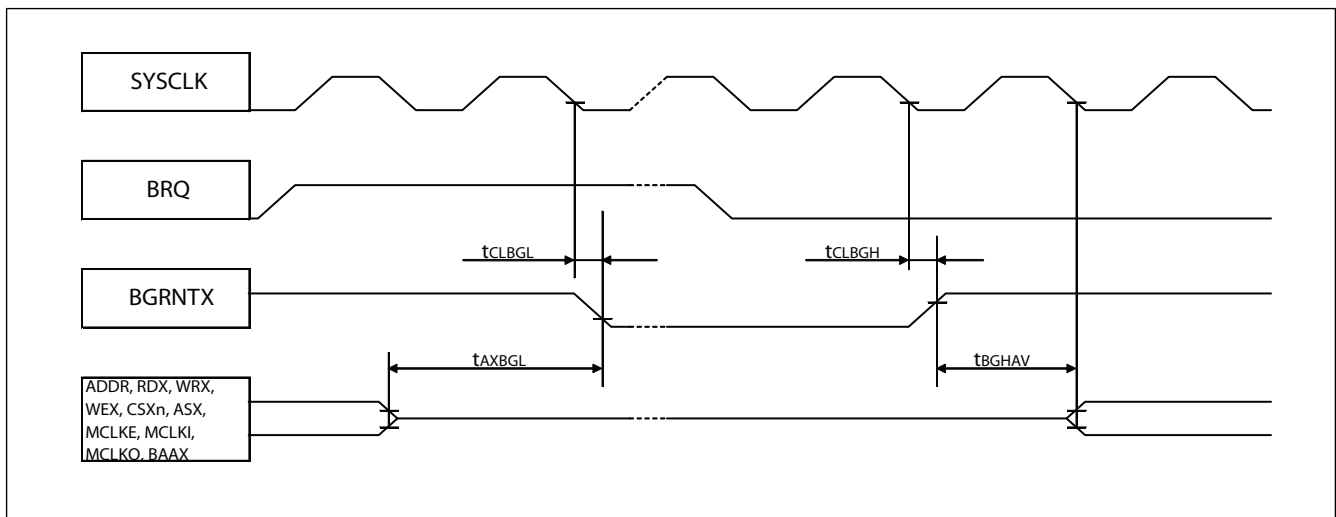

7.8.10. Clock relationships

($V_{DD35} = 3.0\text{ V to }4.5\text{ V}$, $V_{SS5} = AV_{SS5} = 0\text{ V}$, $T_A = -40\text{ }^\circ\text{C to }T_{A(max)}$)

Parameter	Symbol	Pin name	Value		Unit
			Min	Max	
SYSCLK to MCLKO	t_{CSHMH}	SYSCLK	1	5	ns
	t_{CSLML}	MCLKO	0	2	ns
MCLKO ↓ to MCLKE (in sleep mode)	t_{CLML}	MCLKO	—	4	ns
	t_{CLMH}	MCLKE	- 3	—	ns

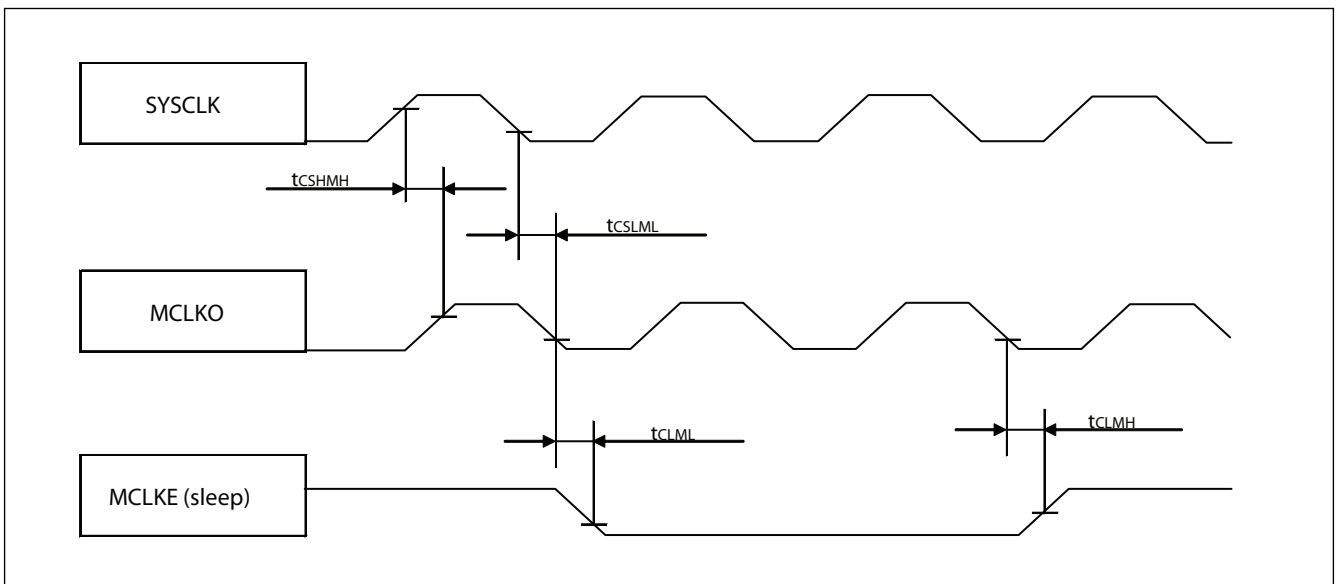

MB91460Q Series

7.8.11. DMA transfer

($V_{DD35} = 3.0\text{ V to }4.5\text{ V}$, $V_{SS5} = AV_{SS5} = 0\text{ V}$, $T_A = -40\text{ }^\circ\text{C to }T_{A(max)}$)

Parameter	Symbol	Pin name	Value		Unit
			Min	Max	
SYSCLK ↓ to DACKX delay time	t_{CLDAL}	SYSCLK	—	9	ns
	t_{CLDAH}	DACKXn	—	7	ns
SYSCLK ↓ to DEOP delay time	t_{CLDEL}	SYSCLK	—	8	ns
	t_{CLDEH}	DEOPn	—	7	ns
SYSCLK ↑ to DACKX delay time (ADDR → CS delayed)	t_{CHDAL}	SYSCLK DACKXn	0	8	ns
SYSCLK ↑ to DEOP delay time (ADDR → CS delayed)	t_{CHDEL}	SYSCLK DEOPn	- 1	8	ns
DREQ setup time	t_{DRQS}	SYSCLK DREQn	25	—	ns
DREQ hold time	t_{DRQH}	SYSCLK DREQn	0	—	ns
DEOTXn setup time	t_{DTXS}	SYSCLK DEOTXn	26	—	ns
DEOTXn hold time	t_{DTXH}	SYSCLK DEOTXn	0	—	ns

Note : DREQ and DEOTX must be applied for at least $5 \times t_{CLKT}$ to ensure that they are really sampled and evaluated.
Under best case conditions (DMA not busy) only setup and hold times are required.

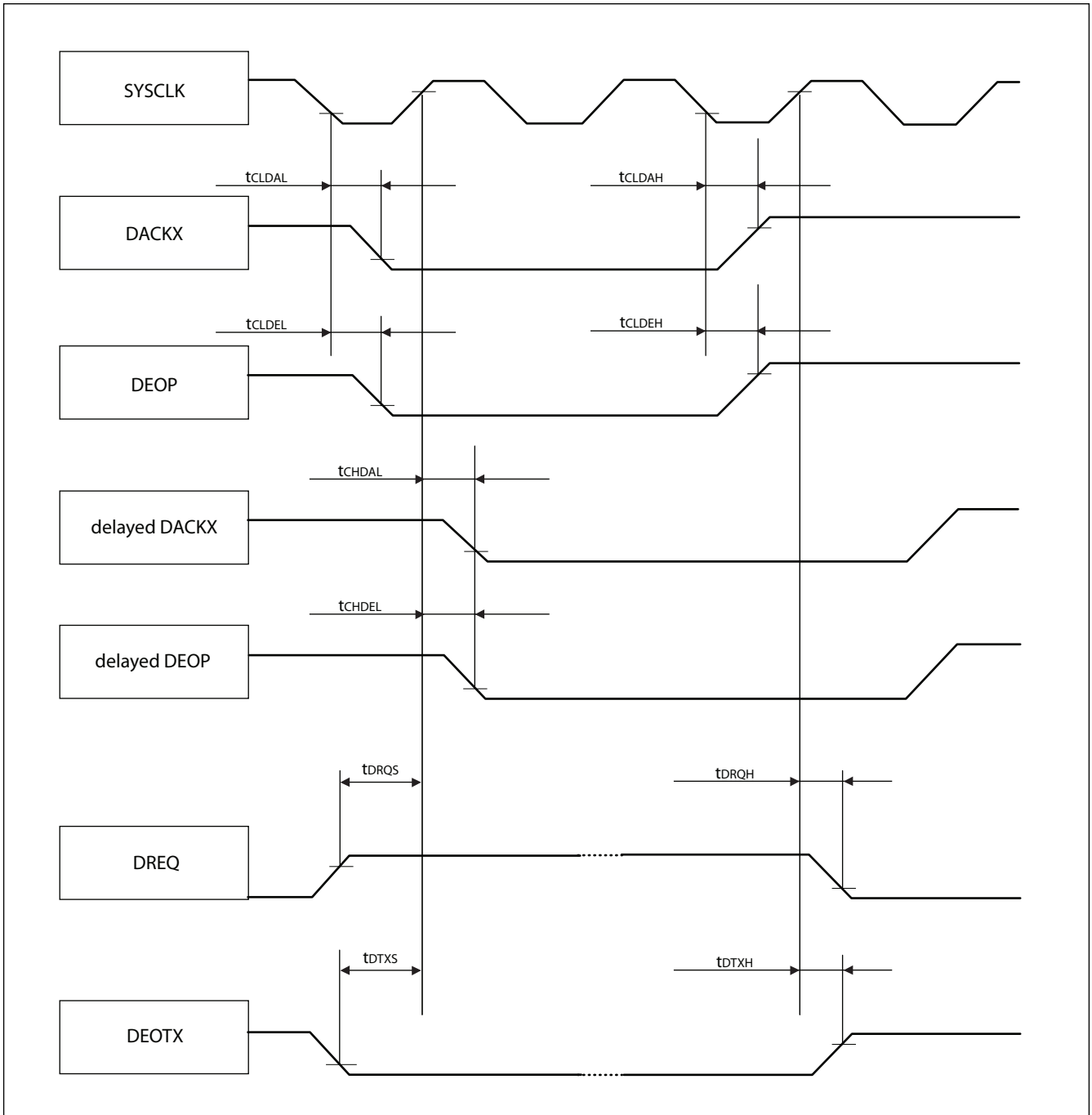

MB91460Q Series

7.8.12. DMA flyby transfer

($V_{DD35} = 4.5 \text{ V to } 5.5 \text{ V}$, $V_{SS5} = AV_{SS5} = 0 \text{ V}$, $T_A = -40 \text{ }^\circ\text{C to } T_{A(max)}$) :

Parameter	Symbol	Pin name	Value		Unit
			Min	Max	
SYSCLK \uparrow to IORDX delay time	t_{CHIRL}	SYSCLK IORDX	- 1	6	ns
	t_{CHIRH}		- 2	3	ns
SYSCLK \uparrow to IOWRX delay time	t_{CHIWL}	SYSCLK IOWRX	0	5	ns
	t_{CHIWH}		- 2	3	ns

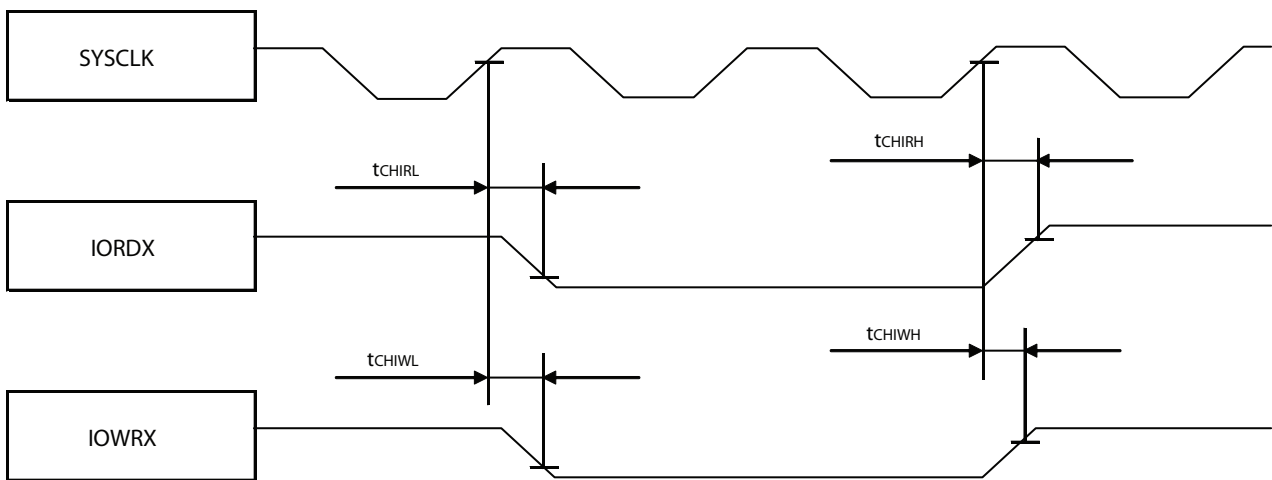

MB91460Q Series

■ ORDERING INFORMATION

Part number	Package	Maximum ambient temperature $T_{A(max)}$	Remarks
MB91F469QAPB-GSE1	320-pin plastic BGA (BGA-320P-M06)	+ 105 °C	Lead-free package
MB91F469QAHPB-GSE1		+ 125 °C	

MB91460Q Series

PACKAGE DIMENSION

FUJITSU SEMICONDUCTOR
DATA SHEET

PLASTIC BALL GRID ARRAY PACKAGE 320 PIN PLASTIC

BGA-320P-M06

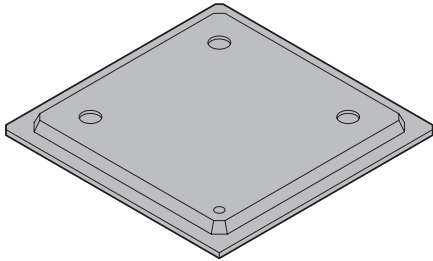
 <p>320-pin plastic PBGA</p> <p>(BGA-320P-M06)</p>	Lead pitch	1.27 mm
	Package width × package length	27.00 mm × 27.00 mm
	Lead shape	Ball
	Sealing method	Plastic mold
	Mounting height	2.46 mm Max
	Weight	2.90 g

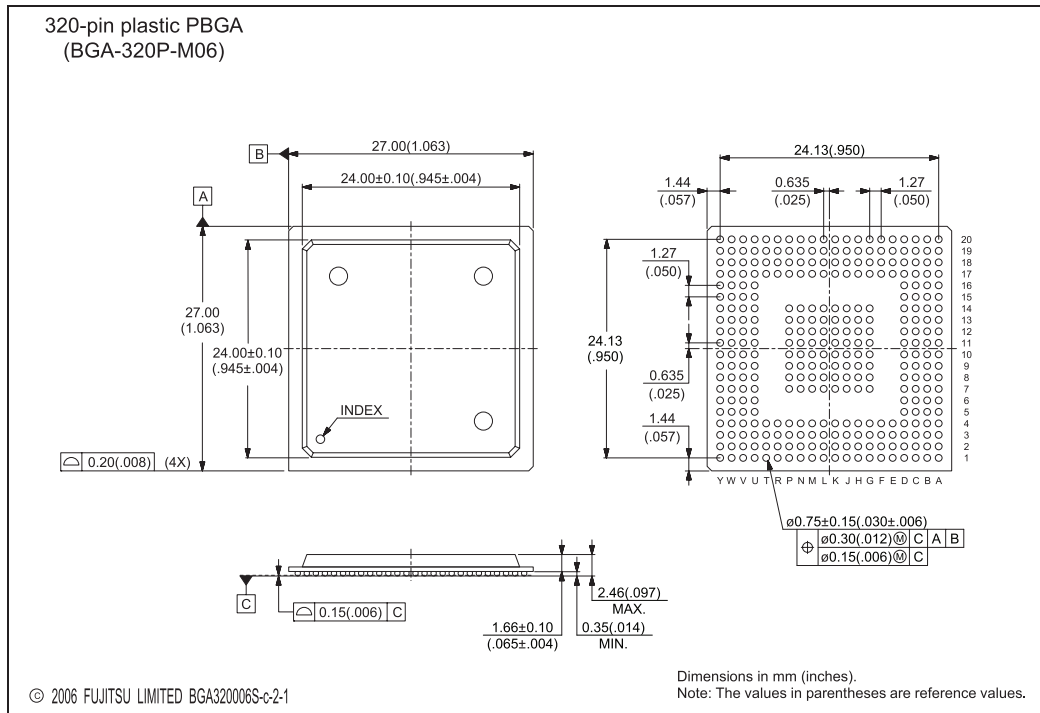

The contents of this document are subject to change without notice.
Customers are advised to consult with FUJITSU sales representatives before ordering.
FUJITSU is unable to assume responsibility for infringement of any patent rights or other rights of third parties arising from the use of the information or package dimensions in this document.

0612

Please check the latest package dimension at the following URL:
<http://edevice.fujitsu.com/package/en-search/>

MB91460Q Series

■ REVISION HISTORY

1. Changes in Preceding Editions

Version	Date	Remark
2.0	2008-01-28	Initial version
2.1	2008-02-05	Pins 257 to 320 are GND.
2.2	2008-02-11	The CANs have only 32-message buffers
2.3	2008-02-15	Corrected product lineup: No NMI function, updated disclaimer at the end
2.4	2008-02-21	ICU8,9: PFR must be 0, DDR recommended 0
2.5	2008-02-22	Corrected naming and size of Flash-cache (F-cache)
2.6	2008-04-30	<ul style="list-style-type: none"> - IO MAP: initial values for LVSEL + REGSEL corrected - Pin 110: CK0 --> CK0/8 (added Free Run Timer 8) - Flash memory operation modes: Added note about the "flash access mode switching" incl. Boot ROM start address - Flash parallel programming: wait times after power-on / INIT added - External Bus AC spec: T_{AXBGL} values corrected - IO Map: removed INT Relocation control registers (was reservation only) - INT Vector Table: Added resource numbers for INT16-23 - added chapter SPECIAL PORT / RESOURCE ASSIGNMENTS
2.7	2008-05-05	INT Vector Table: Added resource numbers for FRT8 and ICU8,9
2.8	2008-05-08	Updated the section about re-located interrupts (Ports 34+35)
2.9	2008-08-18	<ul style="list-style-type: none"> - Corrected I/O circuit type of P24_4 from A to C. - SPECIAL PORT / RESOURCE ASSIGNMENTS: corrected the notes that only digital inputs (no outputs) are disabled if an analog function (ADC) is enabled on this port. - FLASH: Corrected a typo in the note about the "flash access mode switching" incl. address in Boot ROM; added section "Poweron Sequence in parallel programming mode" - IO CIRCUIT TYPE: fixed typos in Remarks - "Notes on PS register" updated - IO Map: Initial values of PFR00 - PFR10 corrected (depend on MD=000) - INT Vector Table: Added Resource number for ADC1 (RN=113); corrected the footnotes - Electrical Characteristics: removed the note that analog input/output pins cannot accept +B signal input. - DC Characteristics: Updated I_L and I_{AIN}, updated I_{LVE} and I_{LVI}, corrected values of Pull up/down resistances, updated and re-ordered the table footnotes - ADC Characteristics: fixed the typos regarding "nonlinearity error" - fixed offset between input channels
2.10	2008-08-19	DC characteristics: updated the current consumption values I _{CC} , I _{CCH} (target values based on MB91F469G)
2.11	2008-09-23	<p>I/O MAP: Removed the notes about new INT disable feature, added bookmarks inside IO MAP</p> <p>Added note to IOS register (addr. 0xC03) "always write 1 to IOS[1]"</p>

MB91460Q Series

Version	Date	Remark
2.12	2008-11-07	PIN Definitions: Corrected pin 145 into P34_5 Flash Security Vector FSV2: Corrected typo in table header Embedded Program/Data Memory (Flash): Added section 7 "Notes About Flash Memory CRC Calculation" (CLKB must be faster then the RC clock) Block Diagram: Added External Bus Instruction Cache Special Port/Resource Assignments: Corrected section "The Additional External Interrupts" (PFR/EPFR/ADERH settings)
2.13	2009-01-09	Special Port/Resource Assignments: Re-located External Interrupts: Corrected that SDA2 is enabled by PFR24 (not by EPFR24) IO Map: Added EPFR34, EPFR35 at address 0x00DE2, 0x00DE3 IO Map: Corrected the table header (address +0,+1,+2,+3) DC characteristics: corrected the current consumption values I_{CC} , I_{CCH}

Page	Section	Changes in DS07-16614-1E
26	■ I/O CIRCUIT TYPES	Changed the table of Type I. Pull-down resistor value: 50 kW approx. → Pull-down resistor value: 50 kΩ approx.
107	■ ELECTRICAL CHARACTERISTICS 4. A/D converter characteristics	Changed the table of "Zero reading voltage". AVRL - 1.5 → AVRL - 1.5 LSB AVRL + 0.5 → AVRL + 0.5 LSB AVRL + 2.5 → AVRL + 2.5 LSB LSB → V Changed the table of "Full scale reading voltage". AVRH - 3.5 → AVRH - 3.5 LSB AVRH - 1.5 → AVRH - 1.5 LSB AVRH + 0.5 → AVRH + 0.5 LSB LSB → V

MB91460Q Series

2. Changes in This Edition

Preceding edition		DS07-16614-1E	(2009-06-24)
Current edition		DS705-00008-1v0-E	(2010-09-03)
Page	Section	Changes	
1	■ DESCRIPTION	Fujitsu Microelectronics → Fujitsu Semiconductor	
3	■ DESCRIPTION 2. Internal peripheral resources	Renamed the Low Voltage detection → Supply Supervisor	
3	■ DESCRIPTION 2. Internal peripheral resources	Removed the note about PHILIPS I ² C license	
3	■ DESCRIPTION 3. Package and technology	Changed Operating temperature range upper limit from + 105 °C → + 105 °C / + 125 °C and added footnote about T _{A(max)}	
4	■ PRODUCT LINEUP	Added MB91FV460B (the new EVA device), and removed lines which are irrelevant for MB91F469Q.	
4	■ PRODUCT LINEUP Software-Watchdog	Renamed "Watchdog timer" → "Software watchdog" Renamed "Watchdog timer (RC osc. based)" → "Hardware-Watchdog (RC osc. based)"	
5	■ PRODUCT LINEUP Temperature Range (TA)	Changed the symbol of ambient temperature from "TA" into "T _A ", changed MB91F469Q upper limit from 105 °C → "T _{A(max)} "	
5	■ PRODUCT LINEUP Power Consumption	Changed the value from < 1W → < 2W	
33	■ HANDLING DEVICES 3. Power supply pins	Corrected typo "capacitator" → "capacitor"	
39	■ CPU AND CONTROL UNIT 3. Programming model 3.1. Basic programming model	Corrected the name of program status register from "RS" → "PS"	
62, 64, 69	■ I/O MAP TCDT0 [R/W] to TCDT8 [R/W]	Free Run Timer 0-8: Changed the TCDT register initialization value from 0xXXXX → 0x0000 (by RST)	
63	■ I/O MAP LIN-USART (FIFO) 11	Corrected RDR00/TDR00 → RDR11/TDR11	
72	■ I/O MAP PFR01 to PFR10	Corrected the foot note number from 4 → 5	
94, 95	■ RECOMMENDED SETTINGS 1. PLL and Clockgear settings, 2. Clock Modulator settings	Added "Please refer to Absolute maximum ratings..."	
102	■ ELECTRICAL CHARACTERISTICS 1. Absolute maximum ratings Permitted operating frequency MB91F469QA, MB91F469QAH	Added these parameters, depending on device, T _A and regulator setting	
102	■ ELECTRICAL CHARACTERISTICS 1. Absolute maximum ratings Permitted power consumption *7	Added these parameters, depending on device and T _A , added the attached footnotes on next page.	

MB91460Q Series

Preceding edition		DS07-16614-1E	(2009-06-24)
Current edition		DS705-00008-1v0-E	(2010-09-03)
Page	Section	Changes	
104	■ ELECTRICAL CHARACTERISTICS 2. Recommended operating conditions Operating temperature	Changed maximum from +105 °C → $T_{A(max)}$ and added remark	
104	■ ELECTRICAL CHARACTERISTICS 2. Recommended operating conditions Lock-up time PLL (4 MHz → 16 ... 100MHz)	Corrected "Look-up time PLL" → "Lock-up time PLL"	
105, 108, 112, 114,	■ ELECTRICAL CHARACTERISTICS 3. DC characteristics, 4. A/D converter characteristics, 5. Alarm comparator characteristics, 7. AC characteristics	Changed the condition on top of the tables from $T_A = -40\text{ °C}$ to +105 °C → $T_A = -40\text{ °C}$ to $T_{A(max)}$ Changed the symbol of ambient temperature from "Ta" → "TA"	
106, 107	■ ELECTRICAL CHARACTERISTICS 3. DC characteristics Input leakage current, Analog input leakage current	Changed the condition from $T_A = 105\text{ °C}$ → $T_A = T_{A(max)}$	
107	■ ELECTRICAL CHARACTERISTICS 3. DC characteristics Power supply current MB91 F469QA, MB91 F469QAH	Added MB91F469QAH, added the I_{cch} parameters for $T_A = 125\text{ °C}$	
108	■ ELECTRICAL CHARACTERISTICS 4. A/D converter characteristics Compare time	Changed $T_{comp\ max}$ from 16,500 μs → "t.b.d." because this parameter is under re-evaluation.	
115	■ ELECTRICAL CHARACTERISTICS 7. AC characteristics 7.2. Reset input ratings	INITX input time (at power-on): Changed t_{INTL} minimum from 8 ms → 10 ms (same as the main oscillator stabilization time).	
152	■ ORDERING INFORMATION	Added product number MB91F469QAHPB-GSE1, added table column defining the maximum ambient temperature $T_{A(max)}$	
153	■ PACKAGE DIMENSION	Corrected the text under the drawings → Please check the latest package dimension at the following URL: http://edevic.fujitsu.com/package/en-search/	
154 156	■ REVISION HISTORY 1. Changes in Preceding Editions 2. Changes in This Edition	Changed the REVISION HISTORY arrangement	

■ MEMO AND DISCLAIMER

MEMO

MEMO

MB91460Q Series

FUJITSU SEMICONDUCTOR LIMITED

Nomura Fudosan Shin-yokohama Bldg. 10-23, Shin-yokohama 2-Chome,
Kohoku-ku Yokohama Kanagawa 222-0033, Japan

Tel: +81-45-415-5858

<http://jp.fujitsu.com/fsl/en/>

For further information please contact:

North and South America

FUJITSU SEMICONDUCTOR AMERICA, INC.

1250 E. Arques Avenue, M/S 333

Sunnyvale, CA 94085-5401, U.S.A.

Tel: +1-408-737-5600 Fax: +1-408-737-5999

<http://www.fma.fujitsu.com/>

Asia Pacific

FUJITSU SEMICONDUCTOR ASIA PTE. LTD.

151 Lorong Chuan,

#05-08 New Tech Park 556741 Singapore

Tel : +65-6281-0770 Fax : +65-6281-0220

<http://www.fmal.fujitsu.com/>

Europe

FUJITSU SEMICONDUCTOR EUROPE GmbH

Pittlerstrasse 47, 63225 Langen, Germany

Tel: +49-6103-690-0 Fax: +49-6103-690-122

<http://emea.fujitsu.com/semiconductor/>

FUJITSU SEMICONDUCTOR SHANGHAI CO., LTD.

Rm. 3102, Bund Center, No.222 Yan An Road (E),

Shanghai 200002, China

Tel : +86-21-6146-3688 Fax : +86-21-6335-1605

<http://cn.fujitsu.com/fmc/>

Korea

FUJITSU SEMICONDUCTOR KOREA LTD.

206 Kosmo Tower Building, 1002 Daechi-Dong,

Gangnam-Gu, Seoul 135-280, Republic of Korea

Tel: +82-2-3484-7100 Fax: +82-2-3484-7111

<http://kr.fujitsu.com/fmk/>

FUJITSU SEMICONDUCTOR PACIFIC ASIA LTD.

10/F., World Commerce Centre, 11 Canton Road,

Tsimshatsui, Kowloon, Hong Kong

Tel : +852-2377-0226 Fax : +852-2376-3269

<http://cn.fujitsu.com/fmc/en/>

Specifications are subject to change without notice. For further information please contact each office.

All Rights Reserved.

The contents of this document are subject to change without notice.

Customers are advised to consult with sales representatives before ordering.

The information, such as descriptions of function and application circuit examples, in this document are presented solely for the purpose of reference to show examples of operations and uses of FUJITSU SEMICONDUCTOR device; FUJITSU SEMICONDUCTOR does not warrant proper operation of the device with respect to use based on such information. When you develop equipment incorporating the device based on such information, you must assume any responsibility arising out of such use of the information.

FUJITSU SEMICONDUCTOR assumes no liability for any damages whatsoever arising out of the use of the information.

Any information in this document, including descriptions of function and schematic diagrams, shall not be construed as license of the use or exercise of any intellectual property right, such as patent right or copyright, or any other right of FUJITSU SEMICONDUCTOR or any third party or does FUJITSU SEMICONDUCTOR warrant non-infringement of any third-party's intellectual property right or other right by using such information. FUJITSU SEMICONDUCTOR assumes no liability for any infringement of the intellectual property rights or other rights of third parties which would result from the use of information contained herein.

The products described in this document are designed, developed and manufactured as contemplated for general use, including without limitation, ordinary industrial use, general office use, personal use, and household use, but are not designed, developed and manufactured as contemplated (1) for use accompanying fatal risks or dangers that, unless extremely high safety is secured, could have a serious effect to the public, and could lead directly to death, personal injury, severe physical damage or other loss (i.e., nuclear reaction control in nuclear facility, aircraft flight control, air traffic control, mass transport control, medical life support system, missile launch control in weapon system), or (2) for use requiring extremely high reliability (i.e., submersible repeater and artificial satellite).

Please note that FUJITSU SEMICONDUCTOR will not be liable against you and/or any third party for any claims or damages arising in connection with above-mentioned uses of the products.

Any semiconductor devices have an inherent chance of failure. You must protect against injury, damage or loss from such failures by incorporating safety design measures into your facility and equipment such as redundancy, fire protection, and prevention of over-current levels and other abnormal operating conditions.

Exportation/release of any products described in this document may require necessary procedures in accordance with the regulations of the Foreign Exchange and Foreign Trade Control Law of Japan and/or US export control laws.

The company names and brand names herein are the trademarks or registered trademarks of their respective owners.

Edited: Fujitsu Semiconductor Europe GmbH

■

Looking for pricing, stock, or lifecycle information?

Click below to explore more details on WIN SOURCE:

- [View MB91F469QAHPB-GSK6E1 on WIN SOURCE](#)
- [Cypress Semiconductor Corp Information](#)

Optimize Your Supply Chain with WIN SOURCE Solutions

- ✓ Global Sourcing Solution
- ✓ Obsolete Management
- ✓ Cost Control Management
- ✓ Shortage Management
- ✓ Alternative Solution
- ✓ Excess Inventory Management