



**THE DATASHEET OF  
CMA3000-A01-1**



## Product Family Specification



**CMA3000-A0X Series**  
3-axis accelerometer

# TABLE OF CONTENTS

- 1 General Description ..... 4**
  - 1.1 Introduction ..... 4
  - 1.2 Functional Description ..... 4
    - 1.2.1 Sensing element ..... 4
    - 1.2.2 Interface IC ..... 4
    - 1.2.3 Factory calibration..... 4
    - 1.2.4 Supported features..... 5
- 2 Electrical Characteristics ..... 5**
  - 2.1 Absolute maximum ratings ..... 5
  - 2.2 Power Supply ..... 5
  - 2.3 Digital I/O Specification ..... 5
    - 2.3.1 Digital I/O DC characteristics..... 5
- 3 Package Characteristics ..... 6**
  - 3.1 Dimensions..... 6
- 4 Application information ..... 7**
  - 4.1 Pin Description..... 7
  - 4.2 Recommended circuit diagram ..... 7
  - 4.3 Recommended PWB layout..... 8
  - 4.4 Assembly instructions..... 9
  - 4.5 Tape and reel specifications ..... 9
- 5 Data sheet references ..... 10**
  - 5.1 Offset ..... 10
    - 5.1.1 Offset calibration error ..... 10
    - 5.1.2 Offset temperature error ..... 10
  - 5.2 Sensitivity ..... 10
    - 5.2.1 Sensitivity calibration error ..... 11
    - 5.2.2 Sensitivity temperature error ..... 11
  - 5.3 Linearity..... 11
  - 5.4 Noise ..... 12
  - 5.5 Bandwidth..... 13
  - 5.6 Cross-axis sensitivity ..... 13
  - 5.7 Turn-on time ..... 14

**6 Known issues ..... 14**

**6.1 Sensing element's bandwidth is lower than the target..... 14**

**7 Order Information..... 15**

**8 Document Change Control..... 16**

**9 Contact Information ..... 17**

## 1 General Description

### 1.1 Introduction

CMA3000-A0X is a three axis accelerometer family targeted for high volume products requiring small size, low price and low power consumption. It consists of a 3D-MEMS sensing element and a signal conditioning ASIC in a wafer level package.

Both block diagram of CMA3000-A0X is shown in Figure 1 below.

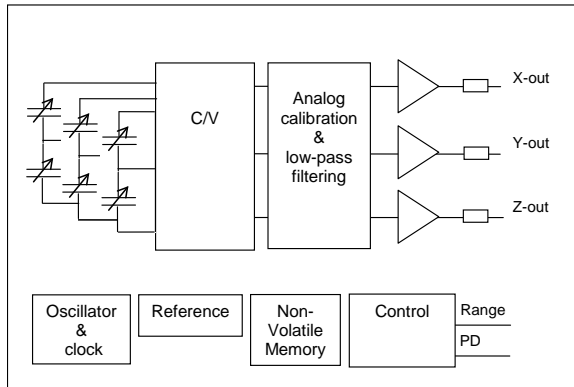

Figure 1. CMA3000-A0X block diagram with analog interface

This document, no. 82821000, describes the product specification (e.g. operation modes, electrical properties and application information) for the CMA3000-A0X family. The specification for an individual sensor is available in the corresponding data sheet.

### 1.2 Functional Description

#### 1.2.1 Sensing element

The sensing element is manufactured using the proprietary bulk 3D-MEMS process, which enables robust, stable and low noise & power capacitive sensors.

The sensing element consists of three acceleration sensitive masses. Acceleration will cause a capacitance change that will be then converted into a voltage change in the signal conditioning ASIC.

#### 1.2.2 Interface IC

CMA3000 includes an internal oscillator, reference and non-volatile memory that enable the sensor's autonomous operation within a system.

The sensing element is interfaced via a capacitance-to-voltage (CV) converter. Following calibration in the analog domain, the signal is filtered and buffered.

In active mode analog voltages representing the measured acceleration are available X-, Y-, Z-out pins. Power Down and measurement range can be selected using external Range ('0'=8g, '1'=2g) and PD ('0' =Active, '1'= Power Down ) pins.

#### 1.2.3 Factory calibration

Sensors are factory calibrated. Trimmed parameters are gain, offset, internal current and voltage references and the frequency of the internal oscillator. Calibration parameters will be read automatically from the internal non-volatile memory during sensor startup.

### 1.2.4 Supported features

Supported features are listed in Table 1 below.

Table 1. CMA3000-A0X devices' summary.

Features	CMA3000-A01
Supply voltage	1.7 V – 3.6 V
Measuring range (selectable)	±2 g, ±8 g
Sensitivity (2g / 8g range)	0.167*Vdd / 0.042*Vdd V/g
Interface	3 analog output voltages, 32 kOhm output impedance External pins for power down and measurement range
Clock	Internal

## 2 Electrical Characteristics

All voltages are reference to ground. Currents flowing into the circuit have positive values.

### 2.1 Absolute maximum ratings

The absolute maximum ratings of the CMA3000 are presented in Table 2 below.

Table 2. Absolute maximum ratings of the CMA3000

Parameter	Value	Unit
Supply voltage ( $V_{dd}$ )	-0.3 to +3.6	V
Voltage at input / output pins	-0.3 to ( $V_{dd} + 0.3$ ), max 3.6	V
ESD (Human body model)	±5	kV
Storage temperature	-40 ... +125	°C
Storage / operating temperature	-40 ... +85	°C
Mechanical shock *	< 10 000	g
Exposure to ultrasonic energy (e.g. ultra sonic washing or welding)	Not allowed	

\* 1 m drop on concrete may cause >>10000 g shock.

### 2.2 Power Supply

Please refer to the corresponding product datasheet.

### 2.3 Digital I/O Specification

#### 2.3.1 Digital I/O DC characteristics

Table 3. DC characteristics of digital I/O pins.

No.	Parameter	Conditions	Symbol	Min	Typ	Max	Unit
Input: PD, RANGE with pull up							
1	Pull up current: PD, RANGE	$V_{IN} = 0 V$	$I_{PD}$	-0.35			μA
2	Input high voltage		$V_{IH}$	0.5*Dvio			V
3	Input low voltage		$V_{IL}$			0.4*Dvio	V

### 3 Package Characteristics

#### 3.1 Dimensions

The package dimensions are presented in Figure 2 below (dimensions in millimeters [mm] with  $\pm 50 \mu\text{m}$  tolerance).

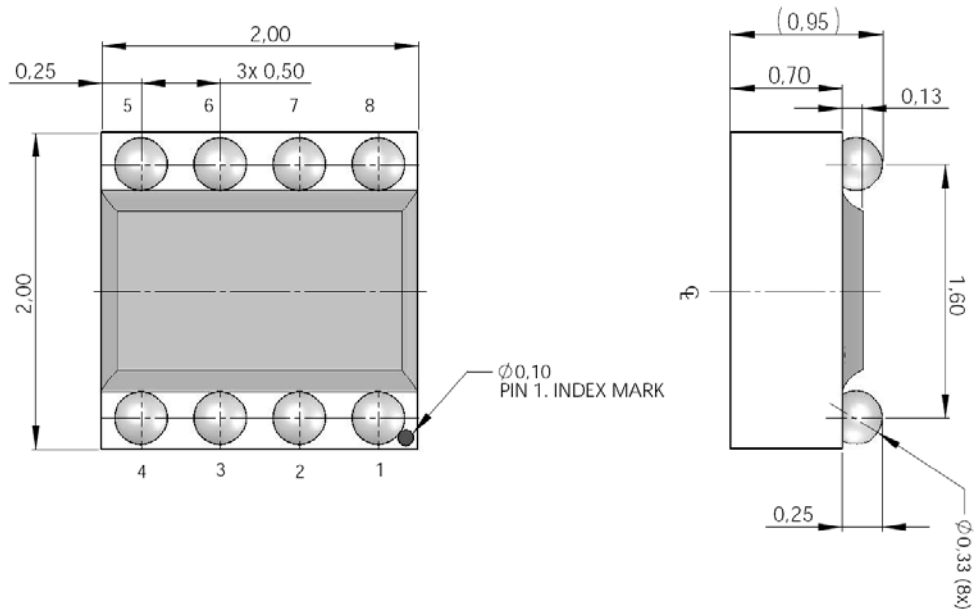

Figure 2. Package dimensions in mm with  $\pm 50 \mu\text{m}$  tolerance for reference only. Please check the corresponding data sheet for details.

## 4 Application information

### 4.1 Pin Description

CMA3000 pin numbers are presented in Figure 4 below and pin descriptions in Table 4.

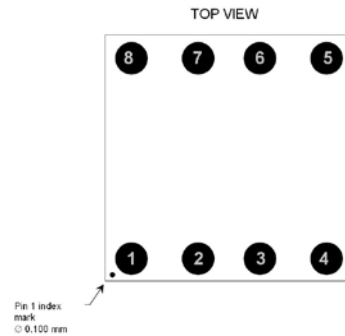
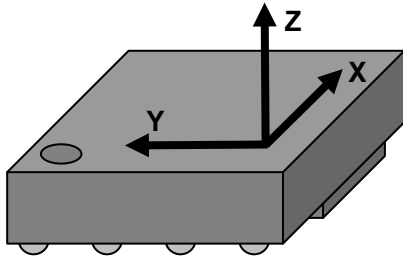

Figure 3. CMA3000 sensing directions.

Figure 4. CMA3000 pin numbers.

Table 4. CMA3000 pin descriptions.

Pin #	Name	CMA3000-A01	
1	VDD	Supply voltage	
2	VSS	Ground	
3	VDD	Supply voltage	
4	VOUTZ	Output voltage Z-channel	
5	PD	Power Down	'0' = Active state '1' = Power Down
6	RANGE	Acceleration Range	'0' = 8g '1' = 2g
7	VOUTX	Output voltage X-channel	
8	VOUTY	Output voltage Y-channel	

### 4.2 Recommended circuit diagram

1. Connect 100 nF SMD capacitor between both supply voltage pins and ground level.
2. Connect 1  $\mu$ F capacitor between each supply voltage and ground level.

Recommended circuit diagram for the CMA3000 is shown in Figure 5 below.

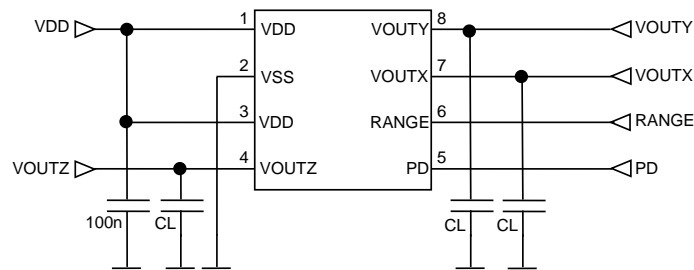

Figure 5. Recommended circuit diagram for CMA3000-A0X

Please note that CMA3000-A0X has internal 32kOhm resistors in series with all analog outputs. Due to this internal resistor the resulting signal bandwidth of CMA3000 will be a function of the  $C_L$  as follows:

$$f_{-3dB} = \frac{1}{2\pi \cdot R \cdot C_L} = \frac{1}{2\pi \cdot 32k\Omega \cdot C_L} ,$$

where  $C_L$  is the load capacitance presented in Figure 5. Some example signal bandwidths are presented in Table 5 below.

Table 5. CMA3000 pin descriptions.

Signal bandwidth, -3dB cut off frequency	Load capacitance, $C_L$
106 Hz	47 nF
50 Hz	100 nF
23 Hz	220 nF
11 Hz	470 nF

### 4.3 Recommended PWB layout

Below are general PWB layout recommendations for CMA3000 products (refer to Figure 5 and Figure 6):

1. Locate 100 nF SMD capacitors right next to the CMA3000 package.
2. Use double sided PWB, connect the bottom side plane to GND.

Recommended PWB pad layout for CMA3000 is presented in Figure 6 below (dimensions in micrometers, [ $\mu\text{m}$ ]).

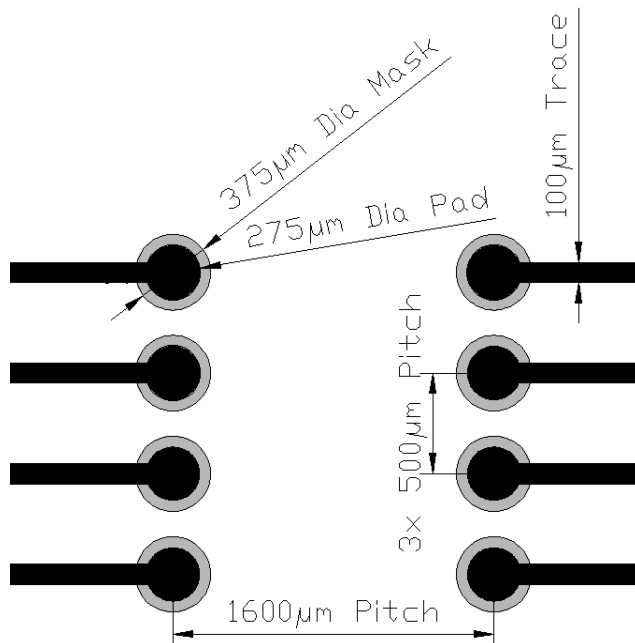

Figure 6. Recommended PWB pad layout for CMA3000.

Recommended PWB layout for the CMA3000-A0X is presented in Figure 7 below (circuit diagram presented in Figure 5 above).

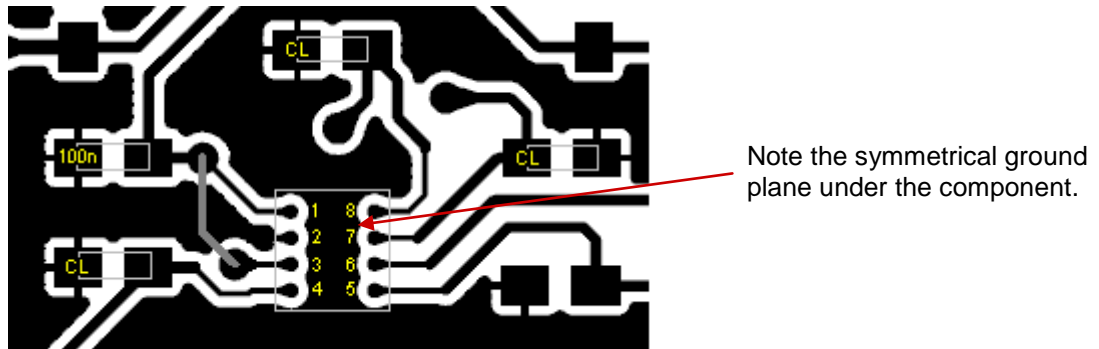

Figure 7. Recommended PWB layout for CMA3000-A0X (not actual size, for reference only).

#### 4.4 Assembly instructions

The Moisture Sensitivity Level (MSL) of the CMA3000 component is 3 according to the IPC/JEDEC J-STD-020D. Please refer to the document TN68\_CMA3000\_Assembly\_Instructions for more detailed information of CMA3000 assembly.

#### 4.5 Tape and reel specifications

Please refer to the document TN68\_CMA3000\_Assembly\_Instructions for tape and reel specifications.

## 5 Data sheet references

### 5.1 Offset

CMA3000's offset will be calibrated in X = 0 g, Y = 0 g, and Z = +1 g (Z measuring axis is parallel to earth's gravitation) position, see Figure 8.

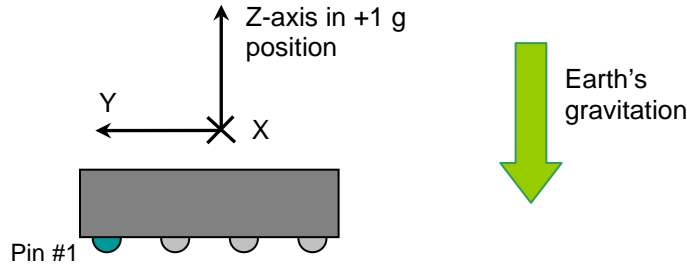

Figure 8. CMA3000 offset (0 g) position.

#### 5.1.1 Offset calibration error

Offset calibration error is the difference between the sensor's actual output reading and the nominal output reading in calibration conditions. Error is calculated by

Equation 1

$$Offset_{X-axisCalibEr} = \frac{Output_{X-axis} - Output}{Sens} \cdot 1000,$$

where  $Output_{X-axisCalibEr}$  is sensor's X-axis calibration error in [mg],  $Output_{X-axis}$  is sensor's X-axis output reading [counts],  $Output$  is sensor's nominal output in 0 g position and  $Sens$  sensor's nominal sensitivity [counts/g].

#### 5.1.2 Offset temperature error

Offset temperature error is the difference between the sensor's output reading in different temperatures and the sensor's calibrated offset value at room temperature. Error is calculated by

Equation 2

$$Offset_{X-axisTempEr@T} = \frac{Output_{X-axis@T} - Output_{X-axis@RT}}{Sens} \cdot 1000,$$

where  $Output_{X-axisTempEr@T}$  is sensor's X-axis temperature error in [mg] in temperature  $T$ ,  $Output_{X-axis@T}$  is sensor's X-axis output reading [counts] in temperature  $T$ ,  $Output_{X-axis@RT}$  X-axis output reading [counts] at room temperature  $RT$  and  $Sens$  sensor's nominal sensitivity [counts/g]. Sensor is in 0 g position for every measurement point.

## 5.2 Sensitivity

During sensitivity calibration, the sensor is placed in  $\pm 1$  g positions having one of the sensor's measuring axis at a time parallel to the earth's gravitation, see Figure 9.

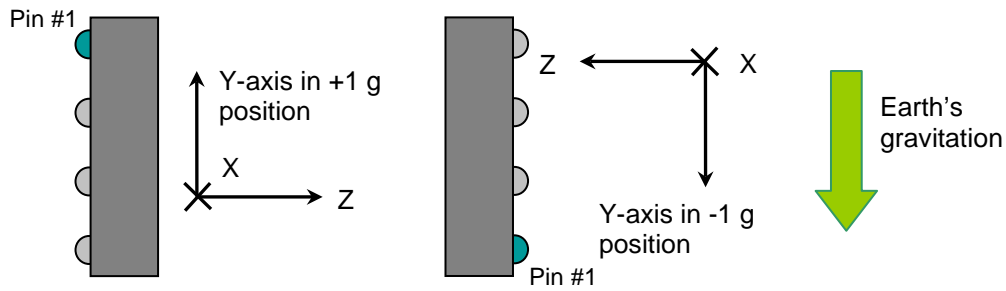

Figure 9. CMA3000 positions for Y-axis sensitivity measurement.

Sensitivity is calculated by

Equation 3

$$Sens_{Y-axis} = \frac{Output_{Y-axis@+1g} - Output_{Y-axis@-1g}}{2g},$$

where  $Sens_{Y-axis}$  is sensor's Y-axis sensitivity in [counts/g],  $Output_{Y-axis@+1g}$  sensor's Y-axis output reading [counts] in +1 g position and  $Output_{Y-axis@-1g}$  is sensor's Y-axis output reading [counts] in -1 g position.

### 5.2.1 Sensitivity calibration error

Sensitivity calibration error is the difference between sensor's measured sensitivity and the nominal sensitivity at room temperature conditions. Error is calculated by

Equation 4

$$Sens_{Y-axisCalibEr} = \frac{Sens_{Y-axis} - Sens}{Sens} \cdot 100\%,$$

where  $Sens_{Y-axisCalibEr}$  is sensor's Y-axis sensitivity calibration error in [%],  $Sens_{Y-axis}$  sensor's Y-axis sensitivity [counts/g] at room temperature conditions and  $Sens$  is sensor's nominal sensitivity [counts/g].

### 5.2.2 Sensitivity temperature error

Sensitivity temperature error is the difference between sensor's sensitivity at different temperatures and the calibrated sensitivity. Error is calculated by

Equation 5

$$Sens_{Y-axisTempEr@T} = \frac{Sens_{Y-axis@T} - Sens_{Y-axis@RT}}{Sens_{Y-axis@RT}} \cdot 100\%,$$

where  $Sens_{Y-axisTempEr@T}$  is sensor's Y-axis sensitivity temperature error in [%] in temperature  $T$ ,  $Sens_{Y-axis@T}$  is sensor's measured Y-axis sensitivity [counts/g] at temperature  $T$  and  $Sens_{Y-axis@RT}$  is sensor's measured Y-axis sensitivity [counts/g] at room temperature  $RT$ .

## 5.3 Linearity

The needed accurate input acceleration in linearity characterization is generated using centrifugal force in centrifuge, see Figure 10. The RPM of the centrifuge is swept so that wanted input acceleration values are applied in parallel to the sensor's measuring axis.

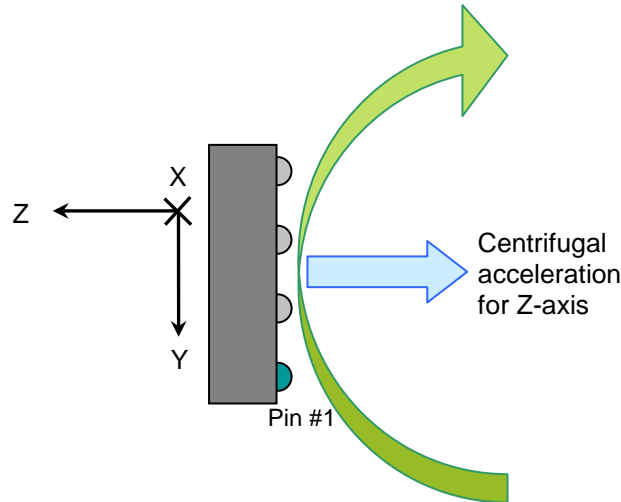

Figure 10. Centrifugal acceleration applied for CMA3000 Z-axis.

Linearity error is the deviation from the best fit straight line. See Figure 11.

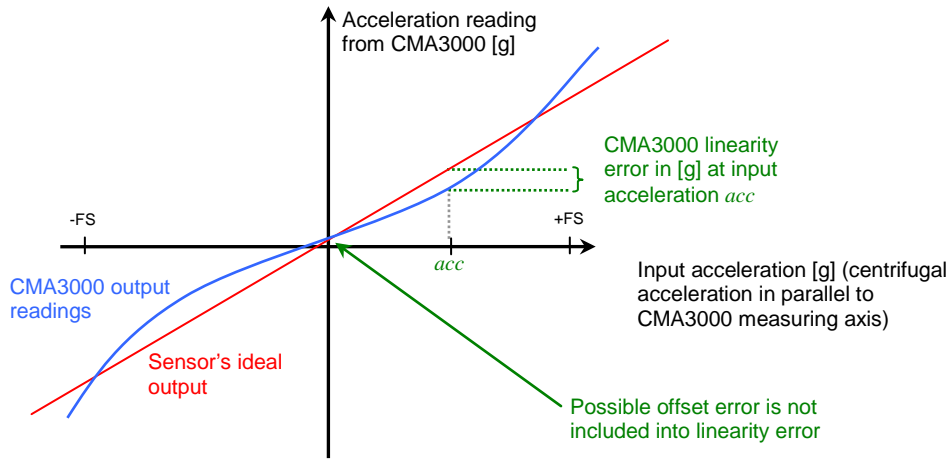

Figure 11. CMA3000's linearity error at input acceleration  $acc$ .

Linearity error is calculated by

Equation 6

$$LinEr_{Z-axis@acc} = \frac{Output_{Z-axis@acc} - Output_{@acc}}{Sens \cdot FS} \cdot 100\% ,$$

where  $LinEr_{Z-axis@acc}$  is sensor's Z-axis linearity error [%FS] on input acceleration  $acc$ ,  $Output_{Z-axis@acc}$  is sensor's measured Z-axis output [counts] on input acceleration  $acc$ ,  $Output_{@acc}$  is sensor's nominal output [counts] on input acceleration  $acc$ ,  $Sens$  is sensor's nominal sensitivity [counts/g] and  $FS$  is sensor's full scale measuring range [g] (for example for CMA3000-A01 with  $\pm 2g$  setting  $\rightarrow FS = 2$  g).

Sensor's ideal output  $Output_{@acc}$  (in Equation 6) is calculated by fitting a straight line to measured accelerations from  $-FS$  to  $FS$ .

## 5.4 Noise

Output noise  $n_x$ ,  $n_y$  and  $n_z$  in X,Y and Z directions is the measured standard deviation of the output values when the sensor is in 0 g position at room temperature. Average noise/axis is calculated by

Equation 7

$$n = \sqrt{\frac{1}{3}(n_x^2 + n_y^2 + n_z^2)},$$

where  $n$  is sensor's noise [g] per axis,  $n_x$  is sensor's X-axis noise [g],  $n_y$  is sensor's Y-axis noise [g] and  $n_z$  is sensor's Z-axis noise [g].

CMA3000 demo-kit design can be used as a reference design for noise measurements, refer to "CMA3000 DEMO KIT User Manual TBD".

## 5.5 Bandwidth

Signal bandwidth is measured in a shaker by sweeping the piston movement frequency with constant amplitude (Figure 12).

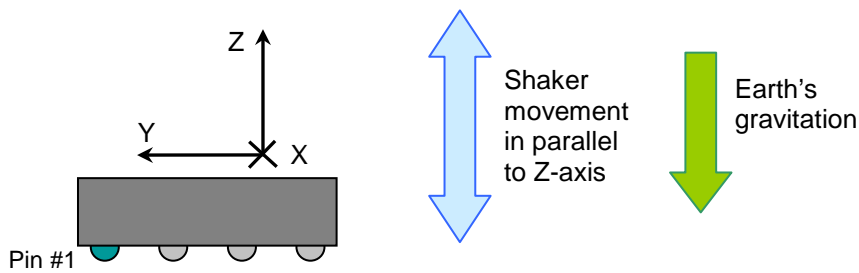

Figure 12. CMA3000 movement in Z-axis bandwidth measurement.

## 5.6 Cross-axis sensitivity

Cross-axis sensitivity is sum of the alignment and the inherent sensitivity errors. Cross-axis sensitivity of one axis is a geometric sum of the sensitivities in two perpendicular directions.

Cross-axis sensitivity [%] of X-axis is given by

Equation 8

$$Cross_x = \pm \frac{\sqrt{S_{XY}^2 + S_{XZ}^2}}{S_x} \cdot 100\%,$$

where  $S_{XY}$  is X-axis sensitivity to Y-axis acceleration [Count/g],  $S_{XZ}$  is X-axis sensitivity to Z-axis acceleration [Count/g] and  $S_x$  is sensitivity of X-axis [Count/g].

Cross-axis sensitivity [%] of Y-axis is given by

Equation 9

$$Cross_y = \pm \frac{\sqrt{S_{YX}^2 + S_{YZ}^2}}{S_y} \cdot 100\%,$$

where  $S_{YX}$  is Y-axis sensitivity to X-axis acceleration [Count/g],  $S_{YZ}$  is Y-axis sensitivity to Z-axis acceleration [Count/g] and  $S_y$  is sensitivity of Y-axis [Count/g].

Cross-axis sensitivity [%] of Z-axis is given by

Equation 10

$$Cross_z = \pm \frac{\sqrt{S_{ZX}^2 + S_{ZY}^2}}{S_z} \cdot 100\%,$$

where  $S_{ZX}$  is Z-axis sensitivity to X-axis acceleration [Count/g],  $S_{ZY}$  is Z-axis sensitivity to Y-axis acceleration [Count/g] and  $S_z$  is sensitivity of Z-axis [Count/g].

Cross-axis sensitivity of CMA3000 family is measured in centrifuge over specified measurement range during qualification. Correct mounting position of component is important during the measurement of cross-axis sensitivity.

## 5.7 Turn-on time

Turn-on time is the time when the last of one X, Y, Z axis output readings stabilizes into its final value after XRESET is pulled high. The final value limits in turn-on time measurements is defined to be  $\pm 1\%$  of the sensor's full scale measuring range (for example for CMA3000-A01  $\pm 2g \rightarrow FS = 2g$ ). Turn-on time definition for Z-axis is presented in Figure 13 below.

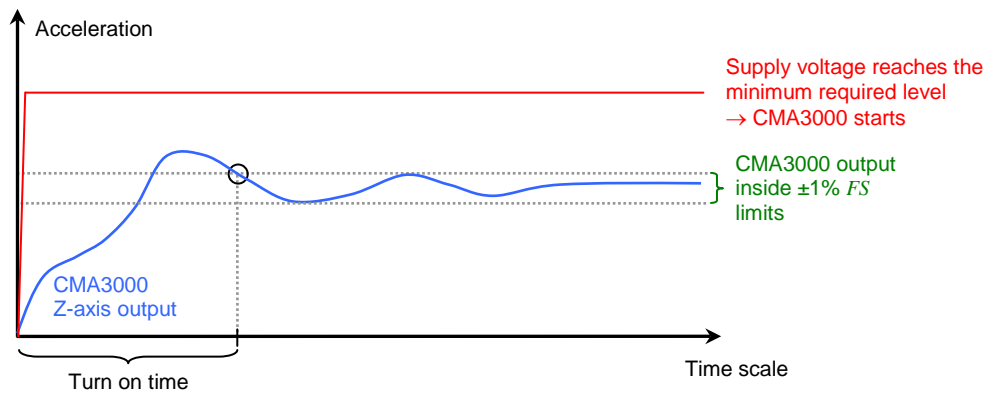

Figure 13. Turn-on time definition for one axis.

## 6 Known issues

### 6.1 Sensing element's bandwidth is lower than the target

Due to design issue (to be corrected) sensing element's mechanical bandwidth is lower than the target. As a result, without external load capacitors the bandwidth to X and Z direction is typically 110 Hz and to Y direction typically 160 Hz.

## 7 Order Information

Order code	Description	Packing	Quantity
CMA3000-A01-1	3-Axis accelerometer with analog interface, +/- 2/8g, 100 pcs	T&R	100
CMA3000-A01-10	3-Axis accelerometer with analog interface, +/- 2/8g, 1000 pcs	T&R	1000
CMA3000-A01-30	3-Axis accelerometer with analog, +/- 2/8g, 3000 pcs	T&R	3000
CMA3000-A01 PWB	PWB assy 3-Axis accelerometer with analog interface, +/- 2/8g	Bulk	1



## 9 Contact Information

### Finland

#### (head office)

VTI Technologies Oy  
P.O. Box 27  
Myllynkivenkuja 6  
FI-01621 Vantaa  
Finland  
Tel. +358 9 879 181  
Fax +358 9 8791 8791  
E-mail: sales@vti.fi

### Japan

VTI Technologies Oy  
Tokyo Office  
Tokyo-to, Minato-ku 2-7-16  
Bureau Toranomom 401  
105-0001  
Japan  
Tel. +81 3 6277 6618  
Fax +81 3 6277 6619  
E-mail: sales.japan@vti.fi

### Germany

VTI Technologies Oy  
Branch Office Frankfurt  
Rennbahnstrasse 72-74  
D-60528 Frankfurt am Main,  
Germany  
Tel. +49 69 6786 880  
Fax +49 69 6786 8829  
E-mail: sales.de@vti.fi

### China

VTI Technologies Shanghai Office  
6th floor, Room 618  
780 Cailun Lu  
Pudong New Area  
201203 Shanghai  
P.R. China  
Tel. +86 21 5132 0417  
Fax +86 21 513 20 416  
E-mail: sales.china@vti.fi



### USA

VTI Technologies, Inc.  
70 South Lake Ave., 10th Floor  
Pasadena, CA 91101  
USA  
Tel +1 626 463 7011  
Fax +1 626 463 7013  
E-mail: sales@vtitechnologies.com





To find out your local sales  
representative visit [www.vti.fi](http://www.vti.fi)

## Looking for pricing, stock, or lifecycle information?

Click below to explore more details on WIN SOURCE:

-  [View CMA3000-A01-1 on WIN SOURCE](#)
-  [Murata Electronics North America Information](#)

## Optimize Your Supply Chain with WIN SOURCE Solutions

-  Global Sourcing Solution
-  Obsolete Management
-  Cost Control Management
-  Shortage Management
-  Alternative Solution
-  Excess Inventory Management