



**THE DATASHEET OF  
PS2915-1-AX**



# PS2501A(L)-1 Datasheet

CEL

[View All Related Products](#) | [Download PDF Datasheet](#)

Datasheet

Products

OPTOIS  
[PS2705A](#)  
Availabl  
Unit Price

OPTOIS  
[PS2501L](#)  
Availabl  
Unit Price

OPTOIS  
[PS2581A](#)  
Availabl  
Unit Price

OPTOIS  
[PS2701-](#)  
Availabl  
Unit Price

OPTOIS  
[PS2561-](#)  
Availabl  
Unit Price

OPTOIS  
[PS2561-](#)  
Availabl  
Unit Price

OPTOIS  
[PS2806-](#)  
Availabl  
Unit Price

SSR RE  
[PS7206-](#)  
Availabl  
Unit Price

SSR RE  
[PS7341-](#)  
Availabl  
Unit Price

OPTOIS  
[PS9308L](#)  
Availabl  
Unit Price

OPTOIS  
[PS2915-](#)  
Availabl  
Unit Price

OPTOIS  
[PS9123-](#)  
Availabl  
Unit Price

OPTOIS  
[PS2561L](#)  
Availabl  
Unit Price

OPTOIS  
[PS2561L](#)  
Availabl  
Unit Price

OPTOIS  
[PS2932-](#)  
Availabl  
Unit Price

OPTOIS  
[PS9821-](#)  
Availabl  
Unit Price

OPTOIS  
[PS2911-](#)

# OPTOCOUPLERS

## Product Selection Guide



Available  
Unit Price

OPTOIS  
PS9306  
Available  
Unit Price

OPTOIS  
PS9331  
Available  
Unit Price

OPTOIS  
PS9303  
Available  
Unit Price

California Eastern Laboratories (CEL) is the exclusive sales and marketing partner in the Americas for Compound Semiconductor Devices from Renesas Electronics Corporation, formerly NEC Electronics Corporation. These products include RF components and RFICs, optocouplers, laser diodes and photo detectors.

Renesas Electronics optocouplers are used in a wide variety of markets including Consumer Electronics, Industrial, Power Supply, Test & Measurement, Datacomm, Lighting Control, Light Durable Goods and more. With over 50 years experience in customer support and fulfillment, CEL is ideally positioned to provide its customers with solutions tailored to meet their specific needs.

CEL maintains extensive inventories and provides engineering and applications assistance at its technical centers in Santa Clara, CA and Wauconda, IL. The company supports customers through sales offices, sales representatives and distributors in numerous locations.



CEL Headquarters

4590 Patrick Henry Drive  
Santa Clara, CA 95054  
Tel: (408) 919-2500

[www.cel.com](http://www.cel.com)

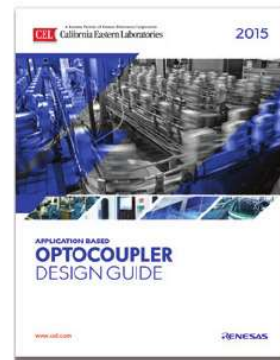

Also available:

Our [Application Based Optocoupler Design Guide](#), the most comprehensive tool for selecting the right Optocoupler to use in our focus applications. We have made selecting the right optocoupler as easy as 1-2-3.

Download your copy at [www.cel.com/Optocouplers](http://www.cel.com/Optocouplers)

## Contents

### Optocouplers

Optocoupler Family Overview and Part Numbering system	4
Transistor Output, IC Output Motor Drive Overview	5
Recommended Optocouplers by Application	6
High Speed Digital Optocouplers	8
Digital Optocouplers for IGBT and MOSFET Motor Drive Applications	10-11
Digital High Functionality Optocouplers for Motor Drive Applications	11-12
Isolation Amplifiers, Digital	12
Isolation Amplifiers, Analog	13-14
High Speed Analog Optocouplers	
Single Transistor Optocouplers	
DC, general purpose	14-15
AC, general purpose	15
Single Transistor Optocouplers, DC & AC Characterized for Low Input Current (1mA)	16-17
Single Transistor Optocouplers, 0.4mm insulation	
DC, high isolation voltage	18
AC, high isolation voltage	19
Single Transistor Optocouplers, High Performance	
DC, devices	19
Single Transistor Optocouplers in Mini-Quad Packages	20
Darlington Transistor Optocouplers	21
Darlington Transistor Optocouplers, 0.4mm insulation	22
Darlington Transistor Optocouplers, High V <sub>CEO</sub> , DC	22
Optocoupler Package Dimensions	23-27
Mounting Pad Dimensions for Optocouplers	28

All information included in this document is current as of the printed date on back. Information is subject to change without notice. Please refer to datasheets or contact your local CEL representative.

For information visit [www.cel.com/optocouplers](http://www.cel.com/optocouplers)

Optocoupler Families Overview, Package Styles and Part Numbering System

Part Number	Description	Package Styles Available	Package Drawing Page
PS23XX Series	Transistor Output	4 pin LSOP (2.54mm pin pitch)	24
PS25XX Series	Transistor Output	4 and 16 pin DIP and DIP SMT	23-25
PS27XX Series	Transistor Output	4 pin SOP (2.54mm pin pitch)	25
PS28XX Series	Transistor Output	4,12 and 16 pin SSOP (1.27mm pin pitch)	25-26
PS29XX Series	Transistor Output	4 pin Mini Flat (flat lead, 1.27mm pin pitch)	26
PS81XX Series	High Speed Analog	5 pin SOP (1.27mm pin pitch)	26
PS83XX Series	High Speed Analog	6 pin SDIP SMT	27
PS85XX Series	High Speed Analog	8 pin DIP and SMT DIP	24
PS88XX Series	High Speed Analog	SO8	26
PS91XX Series	High Speed Digital	5 pin SOP (1.27mm pin pitch)	26
PS93XX Series	High Speed Digital	6 pin SDIP SMT	27
PS94XX Series	High Speed Digital	16 pin SSOP	26
PS95XX Series	High Speed Digital	8 pin DIP and SMT DIP	24
PS98XX Series	High Speed Digital	SO8	26
PS99XX Series	High Speed Digital	8-pin LSDIP	27

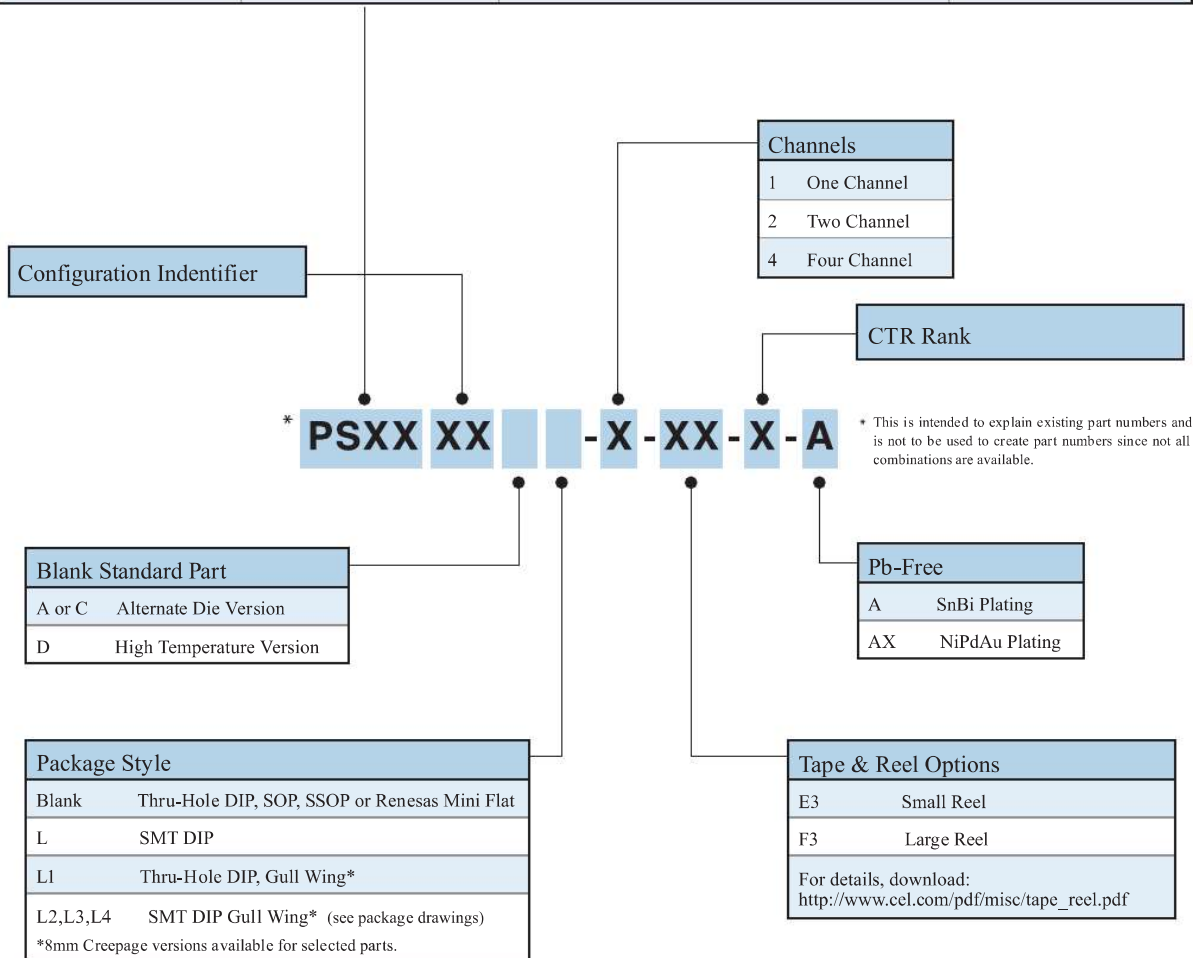

## Transistor Output Series

Function		4-Pin DIP, 5KV iso	SOP, 3.75KV iso	Small SOP, 2.5 KV iso	4-Pin flat lead, 2.5 KV iso	12-Pin SSOP, 1.5 KV iso
Input	Output					
DC	Single	PS2501	PS2381 (Long Creepage, 5KV iso)	PS2801C	PS2911	PS2841
DC	Single	PS2514	PS2701A	PS2811	PS2913	-
DC	Single	PS2561x	PS2703	PS2815	-	-
DC	Single	-	PS2711	PS2861B (3.75KV iso)	-	-
DC	Single	-	PS2761B	-	-	-
DC	Single	-	-	-	-	-
DC	Darlington	PS25x2	PS2702	PS2802	-	-
DC	Darlington	PS253x	PS2733 ( 2.5KV iso )	PS2833	-	-
AC	Single	PS25x5	PS2705A	PS2805C	PS2915	PS2845
AC	Single	-	PS2715	PS2815	-	-
AC	Darlington	PS2506	-	-	-	-

## IC Output

Function			8-Pin DIP 8mm Creepage, 5KV iso	5-Pin SOP, 3.75 KV iso	6-Pin SDIP, 8mm Creepage, 5KV iso	8-Pin Small SOP, 2.5 KV iso	8-Pin LSDIP, 7.5 KV iso
Category	Speed	Output					
High-Speed	1Mbps	Analog	PS8501	PS8101	PS8302L (TA = 110°C)	-	-
High-Speed	1Mbps	Analog	PS8502	-	-	-	-
High-Speed	1Mbps	Digital	PS9513	PS9113	-	PS9822-1/-2	-
High-Speed	1Mbps	Digital	-	PS9122	PS9313L (TA = 110°C)	-	-
High-Speed	1Mbps	Digital	-	-	-	-	-
High-Speed	10Mbps	Digital	PS9587	PS9117A / PS9124	PS9317 / PS9324L	PS9817A-1/-2	PS9924
High-Speed	15Mbps	Digital	-	PS9121	-	PS9821-1/-2	-
High-Speed	15Mbps	CMOS	-	PS9151	PS9351L	PS9851-1/-2	-
High-Speed	15Mbps	Totem Pole Output	-	PS9123	PS9303L (Active High)	-	-
Isolation Amplifier		Analog	PS8551L4 / PS8551AL4	-	-	-	-
		Digital	PS9551AL4	-	-	-	-

## Motor Drive

Function	8-Pin DIP, 8mm Creepage	5-Pin SOP	6-Pin SDIP, 8mm Creepage	8-Pin SDIP, 8mm Creepage	8-Pin LSDIP, 14.5mm Creepage	16-Pin SSOP
Motor Drive (Inverter)	PS9513	PS9113	PS9303L (Active high) PS9309L (Active high)	-	-	
	-	-	PS9313L (TA=110°C)	-	-	
Isolated Gate Driver	0.6A	PS9506	-	PS9306L/PS9307AL	-	
	2.0A	-	-	PS9308L	PS9332L	
	2.5A	PS9531	-	PS9331L	-	PS9905 PS9402

## Recommended Optocouplers by Application

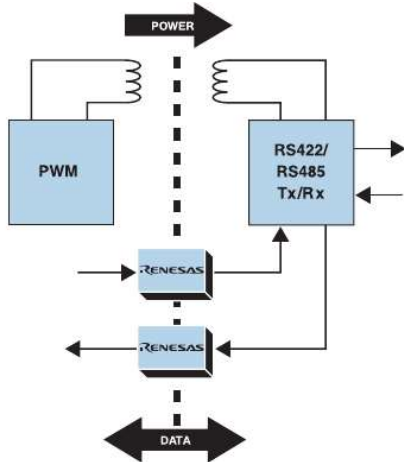

### RS422/485 Interface Isolation

The RS485 serial communications standard is commonly used in data acquisition applications. The standard supports 32 drivers and receivers in a 2- or 4-wire differential configuration with cable lengths up to 4000 feet. Galvanic isolation becomes critical in the prevention of ground loops, electrical noise, and power spikes in widely distributed systems.

#### Application Requirements

- Wide range of data transfer rates: 1 Mbps to 15 Mbps
- High Common Mode Rejection Ratio (CMRR)
- Compact size
- Repeatability
- Reliability

#### Recommended Renesas Optocouplers

##### Tx/Rx Input/Output:

PS8302L, PS9122, PS9313L, PS9822-1, 2 (1 Mbps)  
 PS9124, PS9817A-1, 2, PS9324L, PS9587 (10 Mbps)  
 PS9121, PS9821-1, 2, PS9151, PS9351L, PS9851-1,2 (15 Mbps)

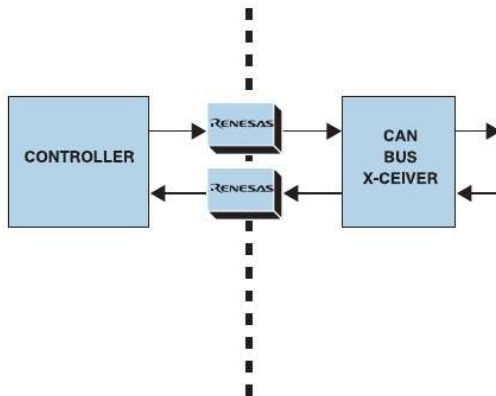

### CAN Interface Isolation

Controller Area Network (CAN) is a serial communications bus popular in industrial applications. Point-to-point and multi-point systems use it to coordinate and synchronize events. Isolation is required in these distributed systems to protect against over-voltage transients, prevent ground loops, and reduce signal distortion.

#### Application Requirements

- Accurate signal timing
- High Common Mode Rejection Ratio (CMRR)
- Compact size
- Repeatability
- Reliability

#### Recommended Renesas Optocouplers

PS9151, PS9123, PS9351L, PS9851-1, 2, PS9121

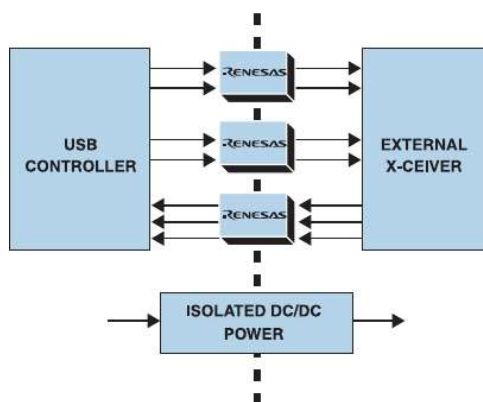

### USB 2.0 Interface Isolation

USB is an inexpensive, high speed bus-integration interface used in computer-based systems. While the USB standard does not mandate isolation, designers recognize its importance in critical systems. Isolation protects USB interfaces from electrostatic discharge (ESD), ground loops, common mode noise, and EMI interference.

#### Application Requirements

- High CMRR
- Compact Size
- Low power consumption
- Data Transfer Rates: up to 15 Mbps
- Reliability

#### Recommended Renesas Optocouplers

PS9121, PS9123, PS9124, PS9151, PS9351L, PS9821-1, 2, PS9851-1, 2

## Recommended Optocouplers by Application

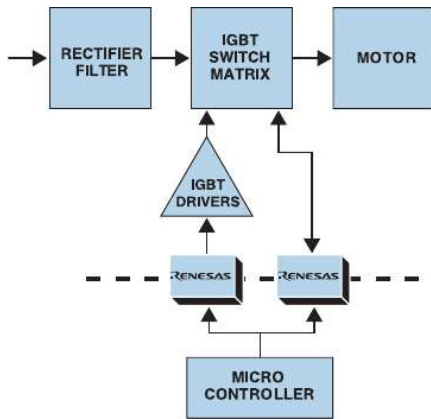

### Motor Drive Control Isolation

Motor controllers combine low level logic with high voltage, high power electronics like Intelligent Power Modules (IPM). Isolation enables communication between the controllers and the drivers at both the high and low side power modules. Faults and other events are typically transferred across this isolation barrier as well.

#### Application Requirements

- Fast response time:  $<0.8\mu\text{s}$
- High Common Mode Rejection Ratio (CMRR):  $>10\text{kV}/\mu\text{s}$
- Isolation: typically 2500V AC - 5000V AC
- Long creepage: up to 8mm

#### Recommended Renesas Optocouplers

PS9113, PS9513, PS9506, PS9402, PS9905, PS9303L, PS9306L, PS9307AL, PS9308L, PS9309L, PS9313L, PS9331L, PS9332L, PS9531

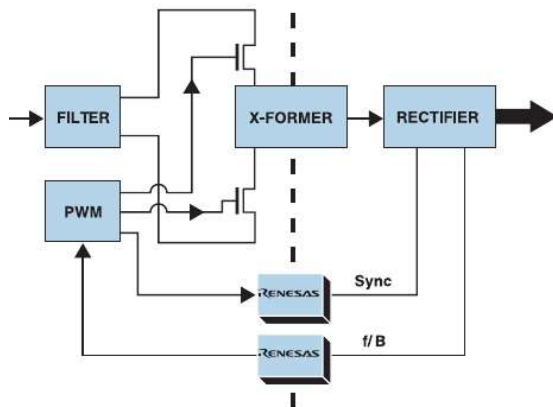

### Power Supply Isolation

Power supplies are used in a wide variety of applications. Galvanic isolation is required for safety and to allow independent secondary side isolation. High speed optocouplers are used to transfer gate drive and synchronous rectification signals from the controller to the switching elements.

#### Application Requirements

- High temperature: up to  $110^{\circ}\text{C}$
- Fast response time
- Low power consumption
- Compact size
- Repeatability

#### Recommended Renesas Optocouplers

Sync: PS8501, PS8101, PS8302L  
 Feedback: PS2381, PS2561D, PS2761B, PS2861B (Transistor Optocouplers)

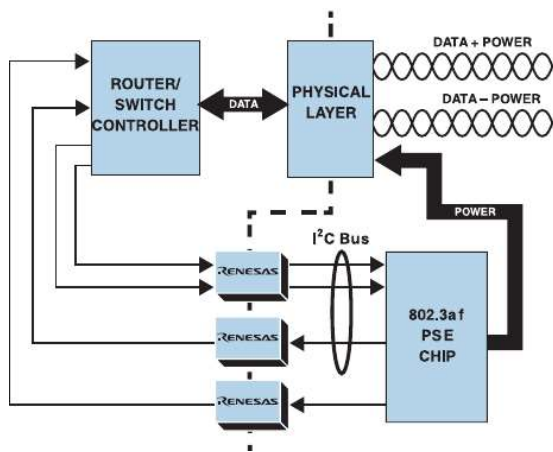

### 802.3af Power over Ethernet (PoE)

PoE offers a simple, reliable, cost effective solution for power transmission. It can deliver 13W of power over existing Ethernet cabling in applications ranging from industrial IT to home office networks. To ensure safety, the 802.3af standard requires 1500V AC of galvanic isolation between the main switch circuitry and the Media Dependent Interface (RJ-45 terminal). The communication from the switch to the PSE chip occurs over an isolated I<sup>2</sup>C bus.

#### Application Requirements

- 3.3V and 5V operation
- 1500VAC minimum isolation
- Small size
- Standard Mode (100 Kbps data rate)
- Fast Mode (400 Kbps data rate)
- Fast Mode + (1Mbps)
- High Speed (3.4 Mbps)

#### Recommended Renesas Optocouplers

PS9122 (Standard Mode)  
 PS9121, PS9122 (Fast Mode)  
 PS9121, PS9821-1, 2, PS9123 (High Speed)  
 PS9122, PS9822 (Fast Mode +)  
 PS2841-4, PS2911 (Transistor Optocouplers)

# High Speed Digital Optocouplers

Package	Part Number	Speed (Mbps)	Vcc Range (V) Recommended	Absolute Max Rating			Typical		Safety Certification <sup>1</sup>
				BV (Vr.m.s.)	I <sub>O</sub> (mA)	I <sub>F</sub> (mA)	t <sub>PHL</sub> (ns)	t <sub>PLH</sub> (ns)	

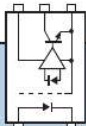

Single channel, open collector output

Isolation for measurement equipment, plasma display panels and factory automation equipment

SOP5	PS9117A	10	4.5 to 5.5	3750	25	30	40	45	UL, VDE, CSA
SOP5	PS9121	15	2.7 to 3.6	3750	25	30	40	45	UL, VDE, CSA
SOP5 <sup>2</sup>	PS9122	1	N = 2.7 to 3.6 L = 4.5 to 5.5	3750	20	25	500 max	700 max	UL, VDE
SOP5	PS9124	10	3.3 to 5.0	3750	25	25	40	45	UL, CSA, VDE

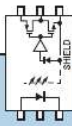
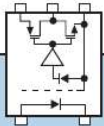

PS9351L

Single channel, CMOS output, -40 to 100°C operation

Isolation for measurement equipment, plasma display panels and factory automation equipment

SOP5	PS9151	15	4.5 to 5.5	3750	2	20	35	35	UL, VDE
SDIP6 Gull Wing	PS9351L	15	4.5 to 5.5	5000	2	25	30	35	UL, CSA, VDE
SDIP6 8mm Creepage	PS9351L2								

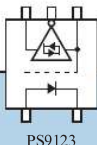
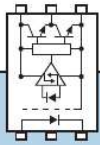

PS9123

Single channel, totem pole output, -40 to 100°C operation

Isolation for IPM Drives, Inverters

SDIP6 Gull Wing	PS9303L	1	4.5 to 20	5000	25	20	185	240	UL, CSA, VDE
SDIP6 8mm Creepage	PS9303L2								
SOP5	PS9123	15	4.5 to 5.5	3750	13	20	28	32	UL, CSA, VDE

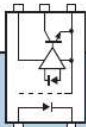

Single channel, open collector output

Isolation for measurement equipment, plasma display panels and factory automation equipment

SDIP6 Gull Wing	PS9317L	10	4.5 to 5.5	5000	25	30	40	35	UL, CSA, VDE
SDIP6 8mm Creepage	PS9317L2								
SDIP6 Gull Wing	PS9324L	10	2.7 to 5.5	5000	25	25	40	50	UL, CSA, SEMKO, VDE
SDIP6 8mm Creepage	PS9324L2								

NOTES: 1. Other safety certifications available, see data sheet. 2. -40 to 100°C operation.

Continued next page

## High Speed Digital Optocouplers Continued...

Package	Part Number	Speed (Mbps)	Vcc Range (V) Recommended	Absolute Max Rating			Typical		Safety Certification <sup>1</sup>
				BV (V.r.m.s.)	I <sub>O</sub> (mA)	I <sub>F</sub> (mA)	t <sub>PHL</sub> (ns)	t <sub>PLH</sub> (ns)	

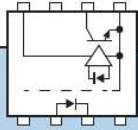

Single channel, open collector output

Isolation for measurement equipment, plasma display panels and factory automation equipment

DIP8 Thru-Hole	PS9587	10	4.5 to 5.5	5000	25	30	35	45	UL, VDE, CSA, BSI, SEMKO, NEMKO, DEMKO, FIMKO
DIP8 Thru-Hole 8mm Creepage	PS9587L1								
SMT DIP8 8mm Creepage	PS9587L2								
SMT DIP8 Gull Wing	PS9587L3								
SO8	PS9817A-1	10	4.5 to 5.5	2500	25	20	40	45	UL, VDE
SO8	PS9821-1	15	2.7 to 3.6	2500	25	20	45	50	UL, VDE
SO8	PS9822-1	1	N = 2.7 to 3.6 L = 4.5 to 5.5	2500	25	20	500 max	700 max	UL, VDE
8pin LSDIP	PS9924	10	2.7 to 5.5	7500	25	25	45	40	UL, CSA, SEMKO, VDE

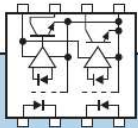

Two channel, open collector output

Isolation for measurement equipment, plasma display panels and factory automation equipment

SO8	PS9817A-2	10	4.5 to 5.5	2500	25	15	40	45	UL, VDE
SO8	PS9821-2	15	2.7 to 3.6	2500	25	15	45	50	UL, VDE
SO8	PS9822-2	1	N = 2.7 to 3.6 L = 4.5 to 5.5	2500	25	15	500 max	700 max	UL, VDE

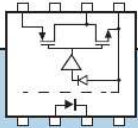

Single channel, CMOS output

Isolation for measurement equipment, plasma display panels and factory automation equipment

SO8	PS9851-1	15	4.5 to 5.5	2500	2	20	34	37	UL, VDE
-----	----------	----	------------	------	---	----	----	----	---------

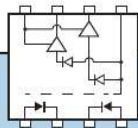

Two channel, CMOS output

Isolation for measurement equipment, plasma display panels and factory automation equipment

SO8	PS9851-2	15	4.5 to 5.5	2500	2	20	34	37	UL, VDE
-----	----------	----	------------	------	---	----	----	----	---------

NOTES: 1. Other safety certifications available, see datasheet.

# Digital Optocouplers for IGBT and MOSFET Motor Drive Applications

Package	Part Number	V <sub>cc</sub> Range (V)	t <sub>PHL</sub> - t <sub>PLH</sub> (ns) max	Typical		BV (V <sub>r.m.s.</sub> )	Safety Certification
				t <sub>PHL</sub> (ns)	t <sub>PLH</sub> (ns)		

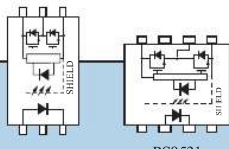
		Single channel for MOSFET, IGBT driver isolation Features - 2.5A Output Current, High CMR (25K-50K V/us), UVLO (Under Voltage Lockout) protection with hysteresis					
SDIP6 Gull Wing	PS9331L	15 to 30	90	105	80	5000	UL, CSA, SEMKO, VDE
SDIP6 Gull Wing 8mm Creepage	PS9331L2						
DIP8 Thru-Hole	PS9531	15 to 30	90	100	80	5000	UL, VDE, CSA, SEMKO
DIP8 Thru-Hole 8mm Creepage	PS9531L1						
SMT DIP8 Gull Wing 8mm Creepage	PS9531L2						
SMT DIP8 Gull Wing	PS9531L3						
8-Pin LSDIP Gull Wing	PS9905	15 to 30	100	100	90	7500	UL, CSA, SEMKO, VDE

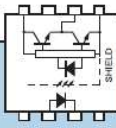
		Single channel for MOSFET, IGBT driver isolation Features - 0.6A Output Current, High CMR(25kV/us)					
DIP8 Thru-Hole	PS9506	10 to 30	300	180	180	5000	UL, VDE, CSA
DIP8 Thru-Hole 8mm Creepage	PS9506L1						
SMT DIP8 Gull Wing 8mm Creepage	PS9506L2						
SMT DIP8 Gull Wing	PS9506L3						

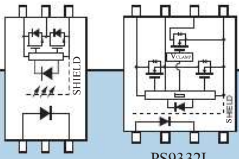
		Single channel for MOSFET, IGBT driver isolation, Industrial inverter, induction heating Features - 2.0A Output Current, High CMR (25K-50kV/us), UVLO (Under Voltage Lock Out) protection with hysteresis					
SDIP6 Gull Wing	PS9308L	15 to 30	100	100	80	5000	UL, CSA, SEMKO, VDE
SDIP6 Gull Wing 8mm Creepage	PS9308L2						
SDIP8 Gull Wing	PS9332L	15 to 30	90	110	75	5000	UL, CSA, SEMKO, VDE
SDIP8 Gull Wing 8mm Creepage	PS9332L2						

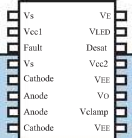
		Single channel for MOSFET, IGBT driver isolation, Industrial inverter, induction heating Features - 2.5A Output Current, High CMR(25kV/us), UVLO (Under Voltage Lock Out) protection with hysteresis, desaturation detection, Miller clamping					
16 pin SSOP	PS9402	15 to 30	100	200	200	5000	UL, CSA, VDE

Continued next page

Motor Drive Isolation

Motor drive applications demand more voltage and current than most ICs and microcontrollers can provide. A variety of devices have been developed to address the problem such as IGBTs, MOSFETs and Intelligent Power Modules (IPMs). These high power drivers use optocouplers to isolate other ICs and components from the power spikes and electrical noise that their motors generate.

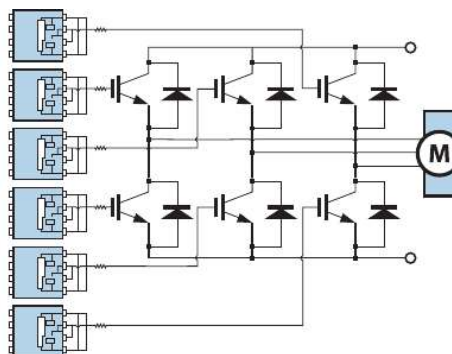

Package	Part Number	Vcc Range (V)	t <sub>PHL</sub> - t <sub>PLH</sub> (ns) max	Typical		BV (V <sub>r.m.s.</sub> )	Safety Certification
				t <sub>PHL</sub> (ns)	t <sub>PLH</sub> (ns)		

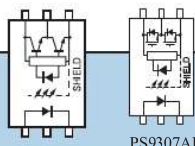

Single channel for MOSFET, IGBT driver isolation  
Features - 0.6A Output Current, High CMR

6 pin SDIP Gull Wing	PS9306L	10 to 30	300	180	180	5000	UL, VDE, CSA, SEMKO
6 pin SDIP Gull Wing 8 mm Creepage	PS9306L2						
6 pin SDIP Gull Wing	PS9307AL	10 to 30	80	100	100	5000	UL, CSA, VDE
6 pin SDIP Gull Wing 8mm Creepage	PS9307AL2						

Digital High Functionality Optocouplers for Motor Drive Applications

Package	Part Number	Vcc Range (V) Recommended	Absolute Max Rating			Typical		Safety Certification <sup>1</sup>
			BV (V <sub>r.m.s.</sub> )	I <sub>O</sub> (mA)	I <sub>F</sub> (mA)	t <sub>PHL</sub> (ns)	t <sub>PLH</sub> (ns)	

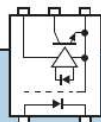

Single channel, open collector output, high temp operation

Isolation for intelligent power module drivers, inverters

SOP5 <sup>2</sup>	PS9113	4.5 to 20	3750	15	25	250	520	UL, VDE, CSA
SDIP6 Gull Wing <sup>3</sup>	PS9313L	4.5 to 20	5000	15	25	240	460	UL, VDE, CSA
SDIP6 Gull Wing 8mm Creepage <sup>3</sup>	PS9313L2							

Continued next page

Digital High Functionality Optocouplers for Motor Drive Applications Continued...

Package	Part Number	V <sub>cc</sub> Range (V) Recommended	Absolute Max Rating			Typical		Safety Certification <sup>1</sup>
			BV (Vr.m.s.)	I <sub>O</sub> (mA)	I <sub>F</sub> (mA)	t <sub>PHL</sub> (ns)	t <sub>PLH</sub> (ns)	

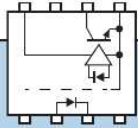

Single channel, open collector output, -40 to 100°C operation

Isolation for intelligent power module drivers, inverters

DIP8 Thru-Hole	PS9513	4.5 to 20	5000	15	25	250	520	UL, VDE, CSA, BSI, SEMKO, NEMKO, DEMKO, FIMKO
DIP8 Thru-Hole 8mm Creepage	PS9513L1							
SMT DIP8 Gull Wing 8mm Creepage	PS9513L2							
SMT DIP8 Gull Wing	PS9513L3							

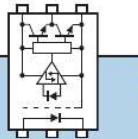

PS9309L

Single channel, totem pole output

Isolation for intelligent power module drivers, inverters

SMT DIP6 Gull Wing	PS9303L	4.5 to 20	5000	25	20	185	240	UL, CSA, VDE
SDIP 6 Gull Wing 8mm Creepage	PS9303L2							
SDID 6 Gull Wing	PS9309L	4.5 to 20	5000	25	20	124	113	UL, CSA, SEMKO, VDE
SDID 6 Gull Wing 8mm Creepage	PS9309L2							

NOTES: 1. Other safety certifications available, see data sheet. 2. -40 to 100°C operation. 3. -40 to 110°C operation.

Isolation Amplifier – Digital

Package	Part Number	V <sub>cc</sub> Range (V) Recommended	Input Supply Current I <sub>DD1</sub> (mA max)	Output Supply Current I <sub>DD2</sub> (mA max)	Resolution (ENOB)	Output Clock Frequency (MHz typ)	BV (Vr.m.s.)	Safety Certification <sup>1</sup>
---------	-------------	--	---	--	----------------------	-------------------------------------	-----------------	-----------------------------------

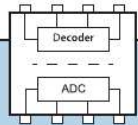

Digital isolation amplifier for motor drive applications

Isolation for intelligent power module drivers, inverters

SMT DIP8 Gull Wing 8mm Creepage	PS9551AL4	4.5 to 5.5	15	15	12	10	5000	UL, CSA, VDE, SEMKO
---------------------------------	-----------	------------	----	----	----	----	------	---------------------

NOTES: 1. Other safety certifications available, see data sheet.

## Isolation Amplifier – Analog

Package	Part Number	Absolute Max Rating		Input Supply Current $I_{DD1}$ (mA max)	Output Supply Current $I_{DD2}$ (mA max)	Output Bandwidth (kHz typ)	Gain V/V (typ)	Gain Error (%)	Safety Certification <sup>1</sup>
		BV (Vr.m.s.)	Vcc (V)						

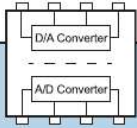

Analog isolation amplifier for motor drive applications, -40 to 100°C operation

SMT DIP8 Gull Wing 8mm Creepage	PS8551L4	5000	5.5	20	16	100	8	±3%	UL, CSA, BSI, VDE, SEMKO
SMT DIP8 Gull Wing 8mm Creepage	PS8551AL4	5000	5.5	16	16	100	8	±1%	UL, CSA, VDE, SEMKO

NOTES: 1. Other safety certifications available, see data sheet.

## High Speed Analog Optocouplers

Package	Part Number	Speed (Mbps)	Absolute Max Ratings				Typical		CTR <sup>1</sup> (N = Full range) Rank (%)	Safety Certification <sup>2</sup>
			BV (Vr.m.s.)	Vcc (V)	IC (mA)	IF (mA)	t <sub>PHL</sub> (ns)	t <sub>PLH</sub> (ns)		

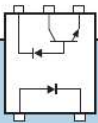

Single channel for power supplies, inverters, computers, peripherals, -55 to 100°C operation

SOP5	PS8101	1	3750	35	8	25	500	600	N = 15 to 35 K = 20 to 35	UL, CSA, VDE
------	--------	---	------	----	---	----	-----	-----	------------------------------	--------------

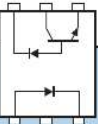

Single channel for power supplies, inverters, computers, peripherals, -55 to 110°C operation

SDIP6 SMT Gull Wing	PS8302L	1	5000	35	8	25	300	330	15 min	UL, VDE, CSA SEMKO
SDIP6 SMT Gull Wing 8mm Creepage	PS8302L2									

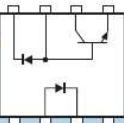

Single channel for measurement and control equipment, modems, inverters, -55 to 100°C operation

DIP8 Thru-Hole	PS8501	1	5000	35	8	25	220	350	15 min	UL, CSA, BSI, VDE, SEMKO
DIP8 Thru-Hole 8mm Creepage	PS8501L1									
SMT DIP8 Gull Wing 8mm Creepage	PS8501L2									
SMT DIP8 Gull Wing	PS8501L3									

Continued next page

High Speed Analog Optocouplers Continued...

Package	Part Number	Speed (Mbps)	Absolute Max Ratings				Typical		CTR <sup>1</sup> (N = Full range) Rank (%)	Safety Certification <sup>2</sup>
			BV (Vr.m.s.)	V <sub>CC</sub> (V)	IC (mA)	IF (mA)	t <sub>PHL</sub> (ns)	t <sub>PLH</sub> (ns)		

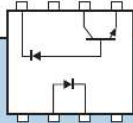

Single channel for measurement and control equipment, modems, inverters, -55 to 100°C operation

DIP8 Thru-Hole	PS8502	1	5000	35	8	25	220	350	15 min	UL, CSA, BSI, VDE, SEMKO
DIP8 Thru-Hole 8mm Creepage	PS8502L1									
SMT DIP8 Gull Wing 8mm Creepage	PS8502L2									
SMT DIP8 Gull Wing	PS8502L3									

Single Transistor, General Purpose DC Optocouplers

Package	Part Number	Absolute Max Ratings				CTR (N = Full range) Rank (%)	Safety Certification
		BV (Vr.m.s.)	V <sub>CEO</sub> (V)	IF (mA)	IC (mA)		

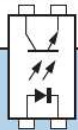

Single channel DC device for low-speed logic applications

CTR measured @ V<sub>CE</sub> = 5V, I<sub>F</sub> = 5mA

SMT DIP4	PS2501AL	5000	70	30	30	N = 50 to 400 H = 80 to 160 W = 130 to 260 Q = 100 to 200 L = 200 to 400	UL
SMT DIP4	PS2501L-1	5000	80	80	50	N = 80 to 600 K = 300 to 600 L = 200 to 400 M = 80 to 240 D = 100 to 300 H = 80 to 160 W = 130 to 260 Q = 100 to 200	UL
SOP4 For high temp applications see PS2761B, page 18	PS2701A	3750	70	30	30	N = 50 to 300 P = 150 to 300 L = 100 to 300 M = 50 to 150	UL, CSA, BSI, VDE
SSOP4 For high temp applications see PS2861B, page 18	PS2801C-1	2500	80	30	30	N = 50 to 400 L = 100 to 300 M = 100 to 400 P = 150 to 300	UL, VDE, CSA, BSI

Continued next page

Single Transistor, General Purpose DC Optocouplers Continued...

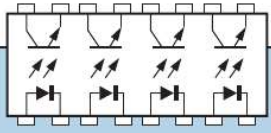
Package	Part Number	Absolute Max Ratings				CTR (N = Full range) Rank (%)	Safety Certification
		BV (Vr.m.s.)	VCEO (V)	IF (mA)	IC (mA)		
		Four channel DC device for low-speed logic applications				CTR measured @ VCE = 5V, IF = 5mA	
SSOP16	PS2801C-4	2500	80	30	30	N = 50 to 400 M = 100 to 400	UL, CSA, BSI, VDE

Single Transistor, General Purpose AC Optocouplers

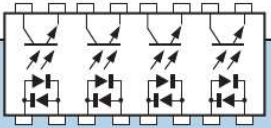
Package	Part Number	Absolute Max Ratings				CTR (N = Full range) Rank (%)	Safety Certification
		BV (Vr.m.s.)	VCEO (V)	IF (mA)	IC (mA)		
		Single channel AC devices with high isolation voltage				CTR measured @ VCE = 5V, IF = 5mA	
DIP4 Thru-Hole	PS2505-1	5000	80	± 80	50	N = 80 to 600	UL
SMT DIP4	PS2505L-1						
SOP4	PS2705A	3750	70	± 30	30	N = 50 to 300 L = 100 to 300 M = 50 to 150	UL, VDE, CSA
SSOP4	PS2805C-1	2500	80	± 30	30	N = 50 to 400 M = 100 to 400	UL, VDE, CSA, BSI
		Four channel AC devices with high isolation voltage				CTR measured @ VCE = 5V, IF = 5mA	
SSOP16	PS2805C-4	2500	80	± 30	30	N = 50 to 400 M = 100 to 400	UL, VDE, CSA, BSI

NOTE: Other safety certifications available, see datasheet.

Single Transistor DC & AC Optocouplers, Characterized for low input current (1 mA)

Package	Part Number	Absolute Max Ratings				CTR (N = Full range) Rank (%)	Safety Certification
		BV (Vr.m.s.)	VCEO (V)	IF (mA)	IC (mA)		

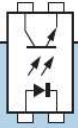

Single channel DC device optimized for power supply applications

CTR measured @ VCE = 5V, IF = 1mA

SOP4	PS2711	3750	40	50	40	N = 100 to 400 K = 200 to 400 L = 150 to 300 M = 100 to 200	UL, VDE
SSOP4	PS2811-1	2500	40	50	40	N = 100 to 400 K = 200 to 400 L = 150 to 300 M = 100 to 200	UL, VDE, CSA
4 Pin Mini Flat	PS2911	2500	40	50	40	N = 100 to 400 K = 200 to 400 L = 150 to 300 M = 100 to 200	UL, VDE, BSI
4 Pin Mini Flat	PS2913	2500	120	50	30	N = 50 to 200 K = 100 to 200 L = 75 to 150 M = 50 to 100	UL, VDE, BSI

Single Transistor DC & AC Optocouplers, Characterized for low input current (1 mA) Continued...

Package	Part Number	Absolute Max Ratings				CTR (N = Full range) Rank (%)	Safety Certification
		BV (V <sub>r.m.s.</sub> )	V <sub>CEO</sub> (V)	I <sub>F</sub> (mA)	I <sub>C</sub> (mA)		

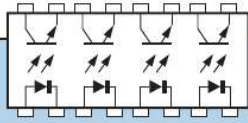

Four channel DC device optimized for power supply applications		CTR measured @ V <sub>CE</sub> = 5V, I <sub>F</sub> = 1mA					
SSOP16	PS2811-4	2500	40	50	40	N = 100 to 400	UL, VDE, CSA

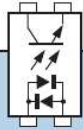

Single channel AC devices optimized for power supply applications		CTR measured @ V <sub>CE</sub> = 5V, I <sub>F</sub> = ±1mA					
SOP4	PS2715	3750	40	±50	40	N = 100 to 400	UL, VDE, BSI, CSA
SSOP4	PS2815-1	2500	40	±50	40	N = 100 to 400	UL, VDE, CSA
4 Pin Mini Flat	PS2915	2500	40	±50	40	N = 100 to 400	UL, VDE, BSI

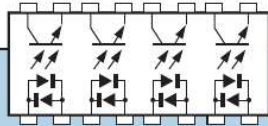

Four channel AC device optimized for power supply applications		CTR measured @ V <sub>CE</sub> = 5V, I <sub>F</sub> = ±1mA					
SSOP16	PS2815-4	2500	40	±50	40	N = 100 to 400	UL, VDE

### Single Transistor DC Optocouplers, Guaranteed 0.4mm Insulation

Package	Part Number	Absolute Max Ratings				CTR (N = Full range) Rank (%)	Safety Certification <sup>1</sup>
		BV (Vr.m.s.)	VCEO (V)	IF (mA)	IC (mA)		

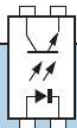

Single channel DC devices, high isolation voltage

CTR measured @ VCE = 5V, IF = 5mA

4 pin LSOP stretched Gull Wing 8mm Creepage -40°C to +115°C operation	PS2381	5000	80	60	50	N = 50 to 400 L = 100 to 300 M = 50 to 150 W = 130 to 260	UL, VDE, CSA, CQC, SEMKO
DIP4 Thru-Hole 110°C operation	PS2561D	5000	80	40	50	N = 50 to 400 H = 80 to 160 L = 200 to 400 Q = 100 to 200 W = 130 to 260	UL, VDE, BSI, CSA, SEMKO, NEMKO, DEMKO, FIMKO
SMT DIP4 110°C operation	PS2561DL						
DIP4 Thru-Hole Gull Wing 110°C operation	PS2561DL1						
SMT DIP4 Gull Wing 110°C operation	PS2561DL2						
DIP4 Thru-Hole 110°C operation	PS2561F	5000	80	30	50	K = 300 to 600	UL
SMT DIP4 Gull Wing 110°C operation	PS2561FL						
SOP4 110°C operation	PS2761B	3750	70	25	40	N = 50 to 400 K = 200 to 400 M = 50 to 150 L = 100 to 300	UL, BSI
SSOP4 110°C operation	PS2861B	3750	70	50	50	N = 50 to 300 L = 100 to 300 M = 50 to 150	UL, BSI, CSA, VDE, CQC, SEMKO, NEMKO, DEMKO, FIMKO

NOTES: 1. Other safety certifications available, see datasheet.

### Single Transistor, with internal base-emitter resistor to increase the switching time

Package	Part Number	Absolute Max Ratings				CTR (N = Full range) Rank (%)	Safety Certification
		BV (Vr.m.s.)	VCEO (V)	IF (mA)	IC (mA)		



Single channel DC device with internal base-emitter resistor to increase the switching time

CTR measured @ VCE = 5V, IF = 5mA

DIP4 Thru-Hole	PS2514	5000	40	30	20	N = 50 to 200	UL, VDE, CSA, CQC
SMT DIP4	PS2514L						

### Single Transistor AC Optocouplers, Guaranteed 0.4mm Insulation (BSI)

Package	Part Number	Absolute Max Ratings				CTR (N = Full range) Rank (%)	Safety Certification <sup>1</sup>
		BV (Vr.m.s.)	VCEO (V)	IF (mA)	IC (mA)		

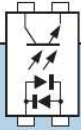

Single channel AC devices, high isolation voltage

CTR measured @ VCE = 5V, IF = 5mA

DIP4 Thru-Hole	PS2565	5000	80	±80	50	N = 80 to 400	UL, VDE, BSI, CSA, SEMKO, NEMKO DEMKO, FIMKO
SMT DIP4	PS2565L						
DIP4 Thru-Hole Gull Wing	PS2565L1						
SMT DIP4 Gull Wing	PS2565L2						

NOTES: 1. Other safety certifications available, see datasheet.

### Single Transistor, High Performance DC Optocouplers

Package	Part Number	Absolute Max Ratings				CTR (N = Full range) Rank (%)	Safety Certification
		BV (Vr.m.s.)	VCEO (V)	IF (mA)	IC (mA)		

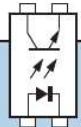

Single channel DC devices, high VCE

CTR measured @ VCE and IF as noted

SOP4	PS2703	3750	120	50	30	VCE = 5V, IF = 5mA N = 50 to 400 K = 200 to 400 L = 100 to 300 M = 50 to 150	UL, VDE, BSI, CSA
4 Pin Mini Flat	PS2913	2500	120	50	30	VCE = 5V, IF = 1mA N = 50 to 200 K = 100 to 200 L = 75 to 150 M = 50 to 100	UL, VDE, BSI

## Single Transistor Optocouplers in Miniature Quad Packages

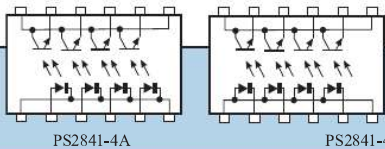
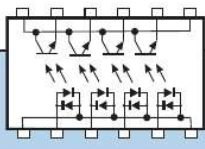
Package	Part Number	Absolute Max Ratings				CTR (N = Full range) Rank (%)	Safety Certification
		BV (Vr.m.s.)	VCEO (V)	IF (mA)	IC (mA)		
		Four channel, DC devices				CTR measured @ VCE = 0.4V, IF = 1mA	
SSOP12	PS2841-4A	1500	70	20	20	N = 100 to 400	UL
SSOP12	PS2841-4B						
		Four channel, AC device				CTR measured @ VCE = 0.4V, IF = 1mA	
SSOP12	PS2845-4A	1500	70	±20	20	N = 100 to 400	UL

## Darlington Transistor, General Purpose Optocouplers

Package	Part Number	Absolute Max Ratings				CTR (N = Full range) Rank (%)	Safety Certification
		BV (Vr.m.s.)	VCEO (V)	IF (mA)	IC (mA)		

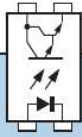

Single channel DC devices, high isolation voltage		CTR measured @ VCE = 2V, IF = 1mA					
DIP4 Thru-Hole	PS2502-1	5000	40	80	200	N = 200 min K = 2000 min L = 700 to 3400 M = 200 to 1000	UL
SMT DIP4	PS2502L-1						
SOP4	PS2702-1	3750	40	50	200	N = 200 min K = 2000 min L = 700 to 3400 M = 200 to 1000	UL, VDE, BSI, CSA
SSOP4	PS2802-1	2500	40	50	90	N = 200 min K = 2000 min L = 700 to 3400 M = 200 to 1000	UL, VDE, BSI, CSA

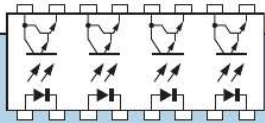

Four channel DC devices, high isolation voltage		CTR measured @ VCE = 2V, IF = 1mA					
SSOP16	PS2802-4	2500	40	50	100	N = 200 min	UL, VDE, BSI, CSA

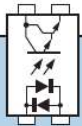

Single channel AC device, high isolation voltage		CTR measured @ VCE = 2V, IF = ±1mA					
DIP4 Thru-Hole	PS2506	5000	40	±80	200	N = 200 min	UL
SMT DIP4	PS2506L						

Darlington Transistor Optocouplers, Guaranteed 0.4mm insulation (BSI)

Package	Part Number	Absolute Max Ratings				CTR (N = Full range) Rank (%)	Safety Certification <sup>1</sup>
		BV (Vr.m.s.)	VCEO (V)	IF (mA)	IC (mA)		



Single channel DC device, high isolation voltage		CTR measured @ VCE = 2V, IF = 1mA					
DIP4 Thru-Hole	PS2562	5000	40	80	200	N = 200 min K = 2000 to 3400 L = 700 to 3400 M = 200 to 1000	UL, VDE, BSI, CSA, NEMKO, SEMKO, DEMKO, FIMKO
SMT DIP4	PS2562L						
DIP4 Thru-Hole Gull Wing	PS2562L1						
SMT DIP4 Gull Wing	PS2562L2						

NOTES: 1. Other safety certifications available, see datasheet.

Darlington Transistor, High VCEO DC Optocouplers

Package	Part Number	Absolute Max Ratings				CTR (N = Full range) Rank (%)	Safety Certification <sup>1</sup>
		BV (Vr.m.s.)	VCEO (V)	IF (mA)	IC (mA)		

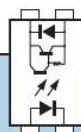

Single channel DC devices		CTR measured @ VCE = 2V, IF = 1mA					
DIP4 Thru-Hole	PS2533	5000	350	80	150	N = 1500 to 6500	UL, VDE, BSI, CSA
SMT DIP4	PS2533L						
SOP4	PS2733	2500	350	50	150	N = 1500 min	UL, VDE, BSI, CSA
SSOP4	PS2833-1	2500	350	50	60	N = 400 to 4500	UL, VDE, CSA

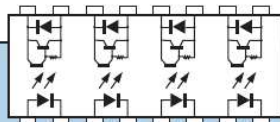

Four channel DC device		CTR measured @ VCE = 2V, IF = 1mA					
SSOP16	PS2833-4	2500	350	50	60	N = 400 to 4500	UL

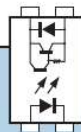

Single channel DC devices		CTR measured @ VCE = 2V, IF = 1mA					
DIP4 Thru-Hole	PS2535	5000	350	50	120	N = 400 to 5500 L = 1500 to 5500	UL, VDE, BSI
SMT DIP4 Gull Wing	PS2535L						

Optocoupler Package Dimensions Dimensions in millimeters. Dimensions are nominal, please refer to datasheets.

DIP4 Thru-Hole

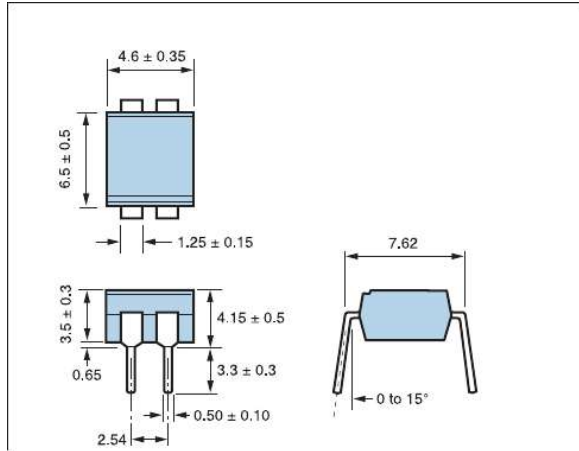

L — SMT DIP4

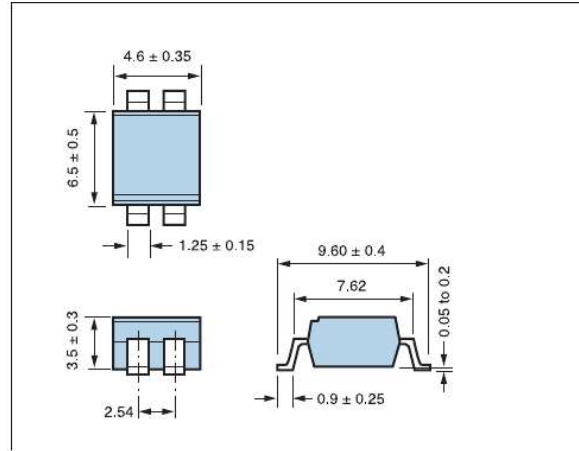

L1 — DIP4 Thru-Hole Gull Wing

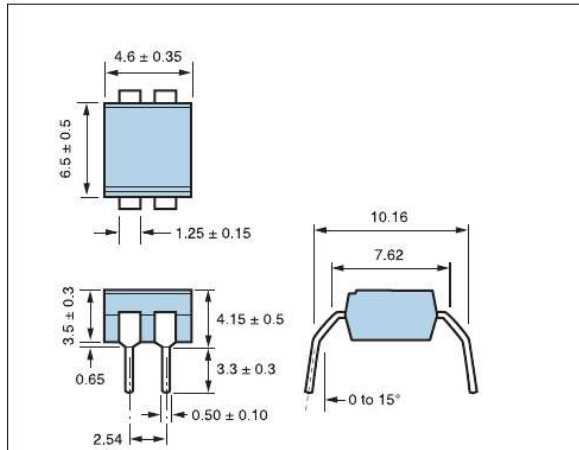

L2 — SMT DIP4 Gull Wing

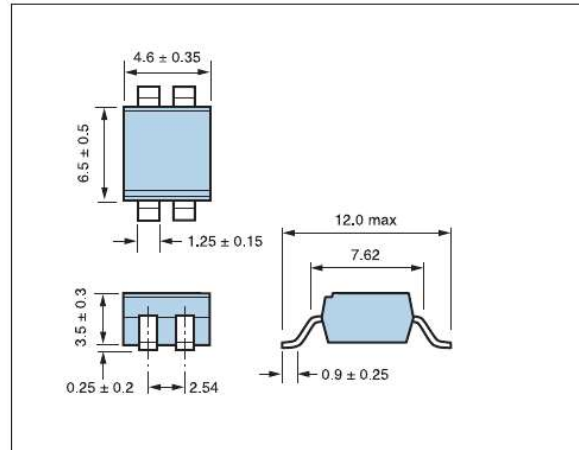

L1 — DIP4 Thru-Hole Gull Wing with 8mm Creepage

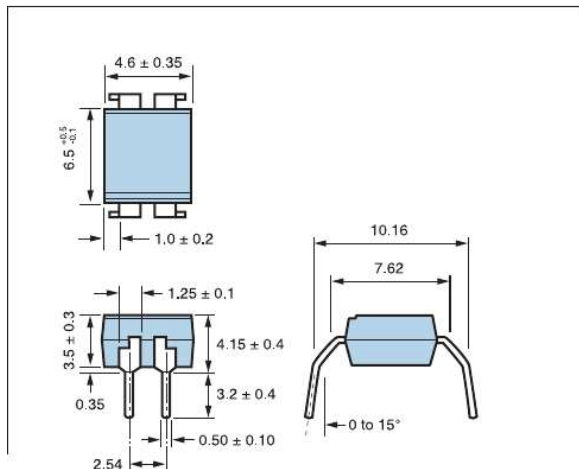

L2 — SMT DIP4 Gull Wing with 8mm Creepage

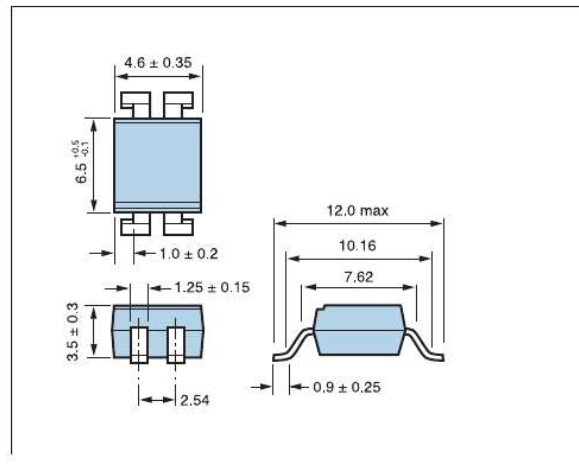

4-Pin LSOP

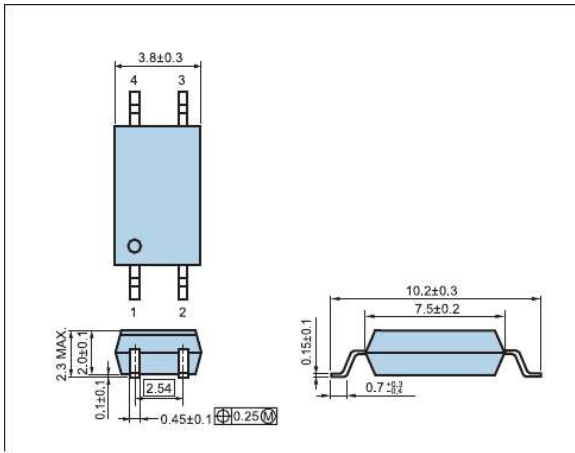

8-Pin SDIP

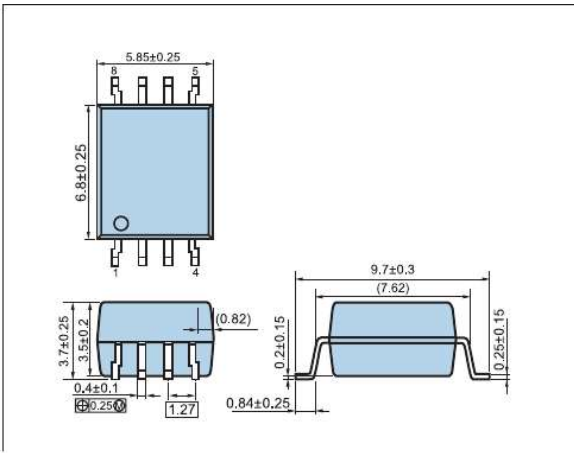

DIP8 Thru-Hole

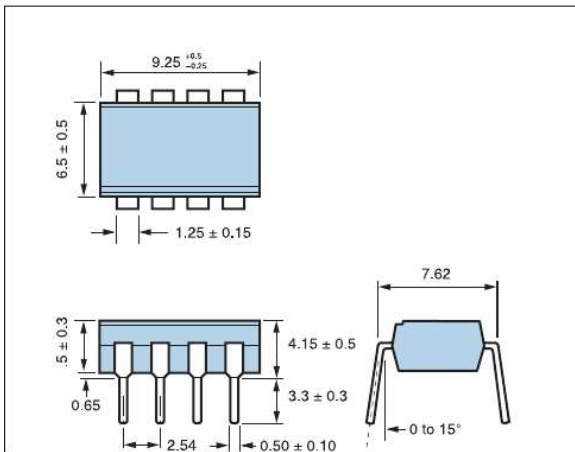

L — SMT DIP8

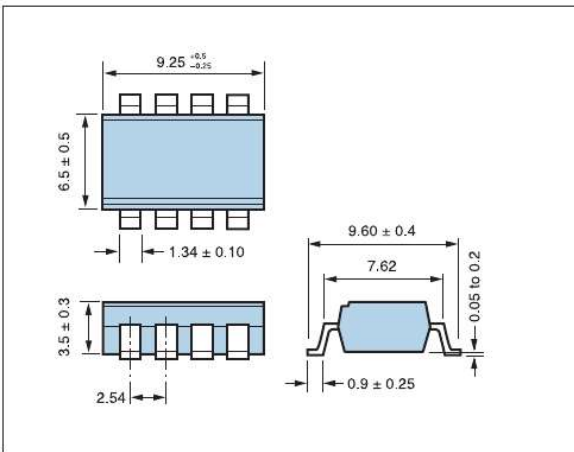

L1 — DIP8 Thru-Hole with 8mm Creepage

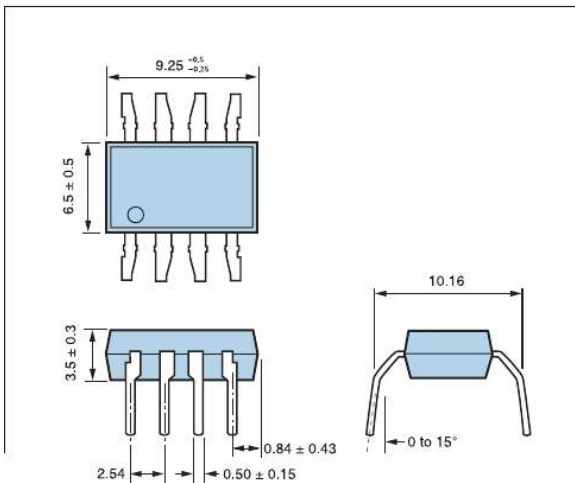

L2 — SMT DIP8 Gull Wing with 8mm Creepage

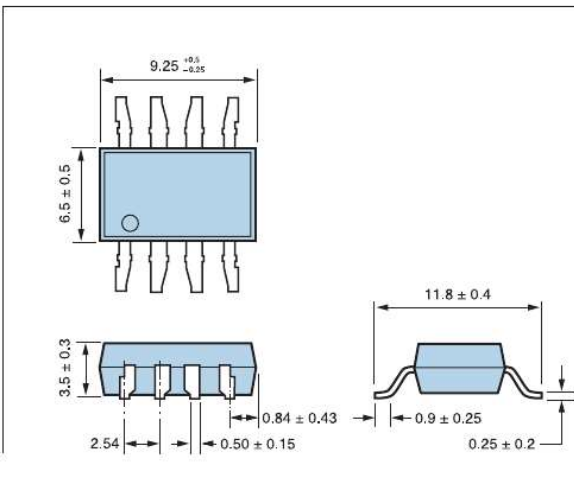

L3 — SMT DIP8 Gull Wing

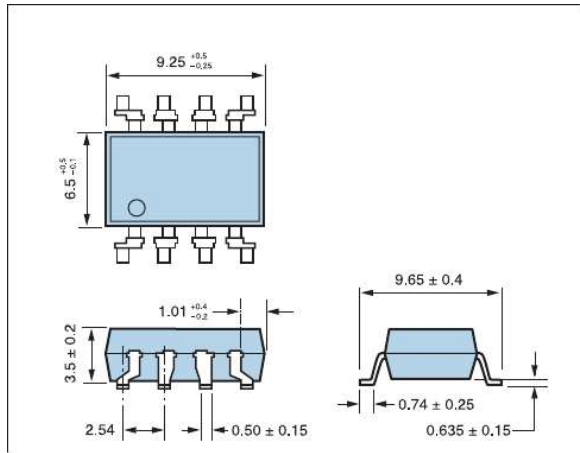

L4 — SMT DIP8 Gull Wing with 8mm Creepage

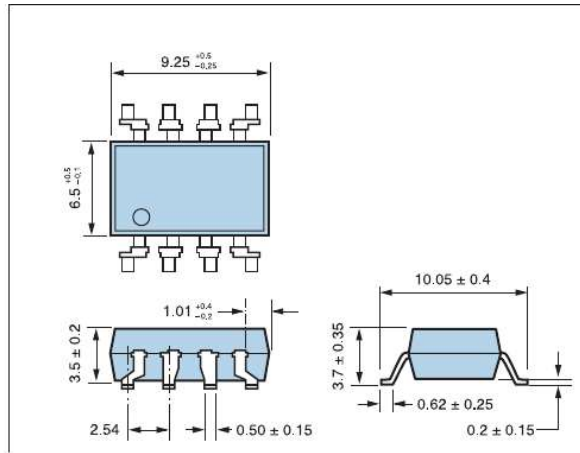

DIP16 Thru-Hole

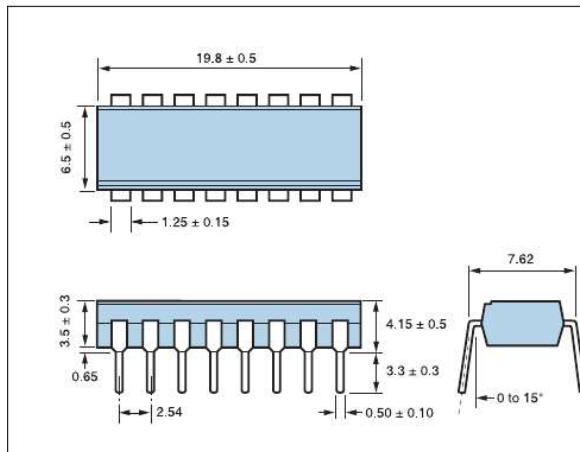

L — SMT DIP16

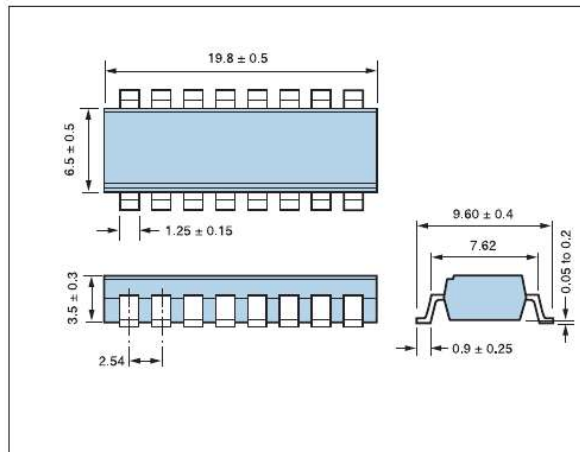

SOP4 2.54mm pin pitch

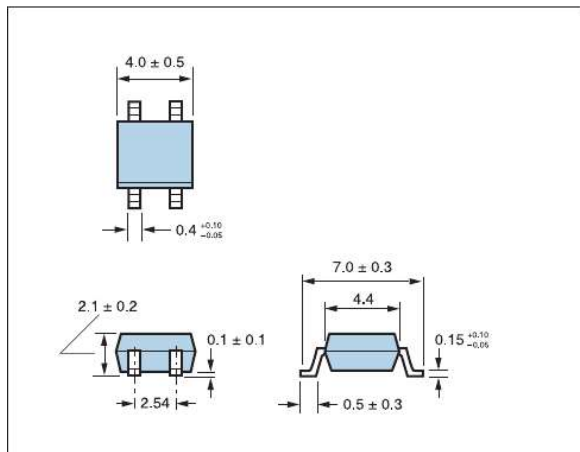

SSOP4 1.27mm pin pitch

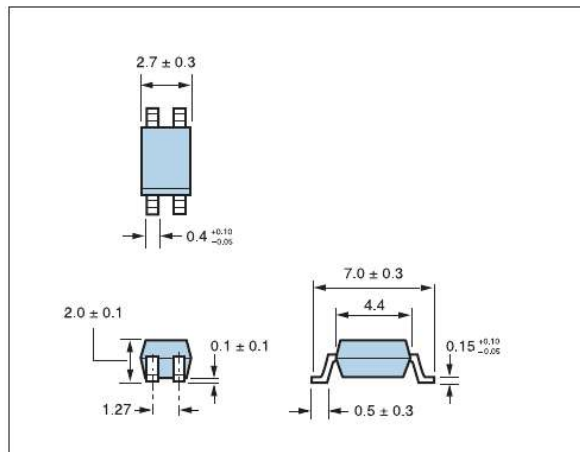

SOP5 1.27mm pin pitch

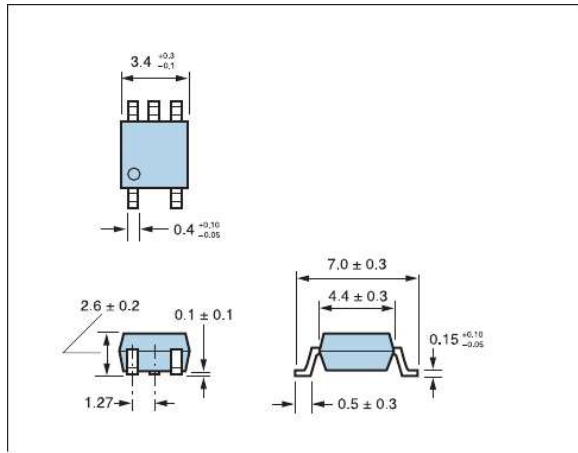

SOP5 1.27mm pin pitch with 5.5mm Creepage

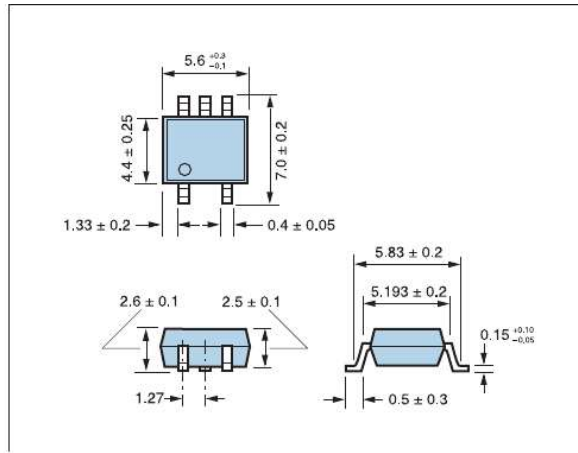

S08 1.27mm pin pitch

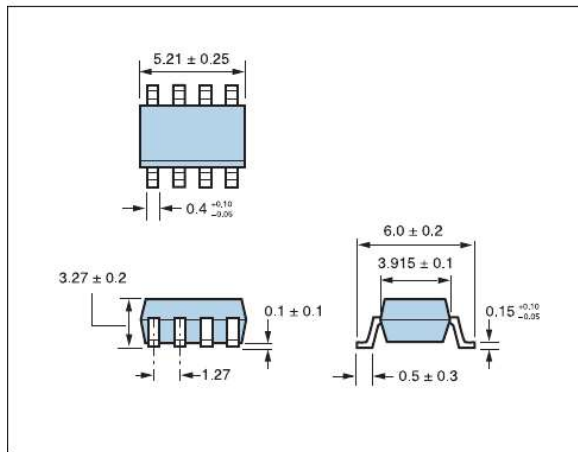

SSOP12 Mini Quad 1.27mm pin pitch

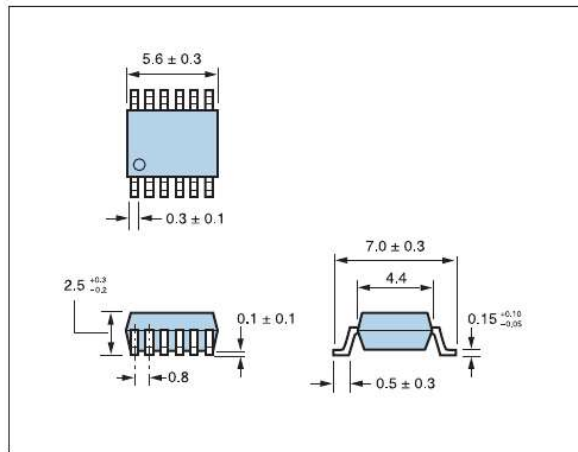

SSOP16 1.27mm pin pitch

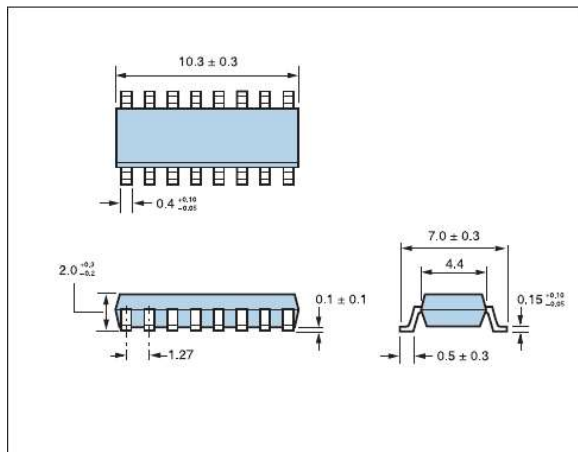

4-Pin Mini Flat

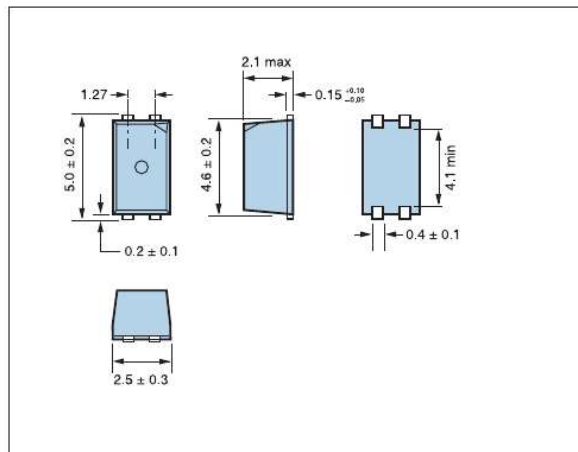

Optocoupler Package Dimensions Continued... Dimensions in millimeters. Dimensions are nominal, please refer to datasheets.

L — SDIP6 SMT Gull Wing

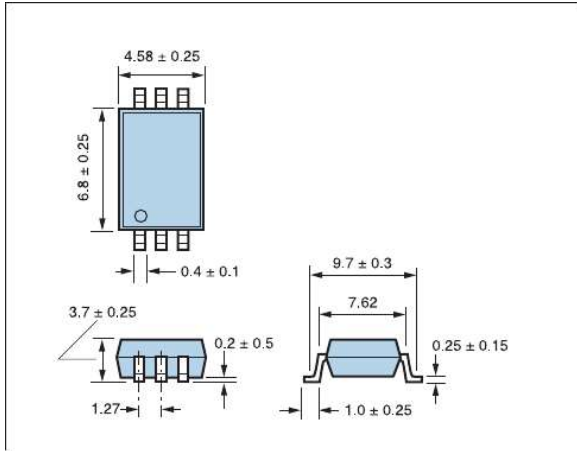

L2 — SDIP6 SMT Gull Wing with 8mm Creepage

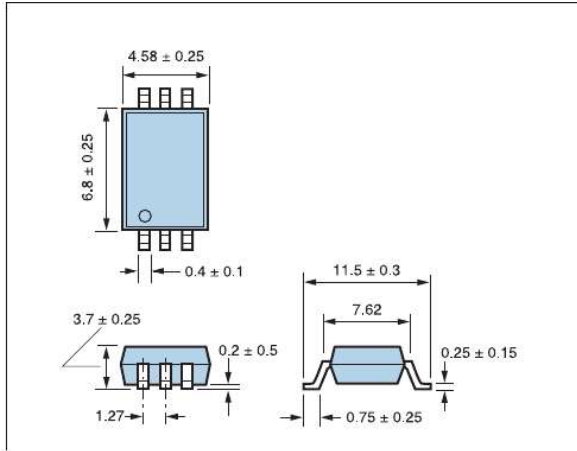

8-Pin LSDIP

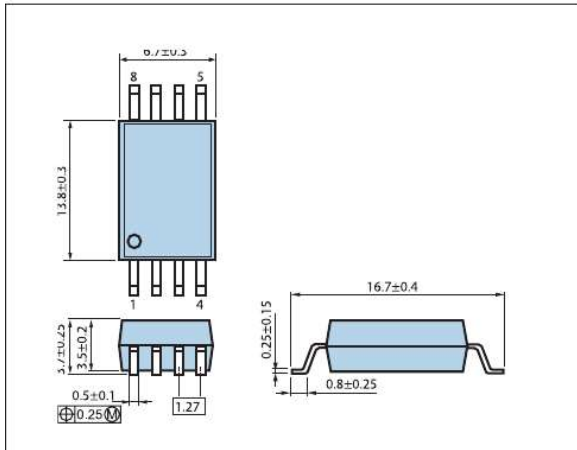

16-Pin SSOP

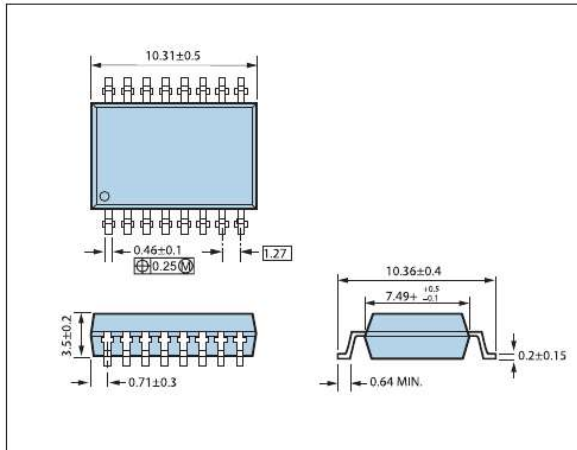

## Mounting Pad Dimensions for Optocouplers

Package	A	B1	B2	C	D
---------	---	----	----	---	---

Surface Mount DIP, SOP and SSOP Packages (mm)					
DIP (SMT) 4, 6, 8, 12, 16 Pin	8.2	-	2.54	1.7	2.2
DIP (L2 – SMT) 4, 6, 8, 16 Pin	10.2	-	2.54	1.7	2.2
SOP 4, 8, 16 Pin	6.25	-	2.54	0.8	1.45
SOP 5 Pin	6.25	1.27	2.54	0.8	1.45
SSOP 4, 16 Pin 1.27mm Pitch	6.25	-	1.27	0.8	1.45
SSOP 8 Pin (SO-8) 1.27mm Pitch	5.25	-	1.27	0.8	1.45
SSOP 12 Pin 0.8mm Pitch	6.25	-	0.8	0.5	1.45
LSDIP 8 Pin	16.6	-	1.27	0.9	2
SDIP 6 Pin	9.2	-	1.27	0.8	2.2

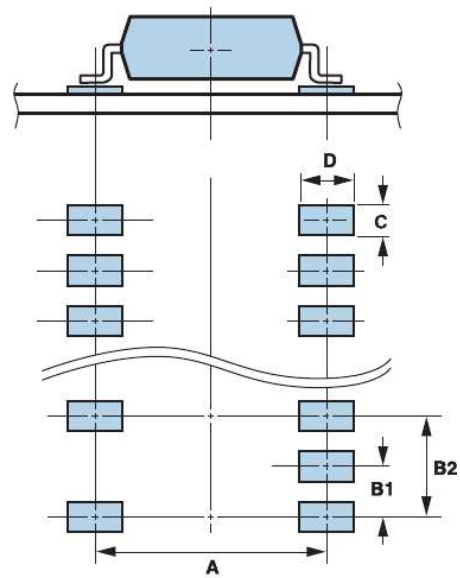

Package	A	B	C
---------	---	---	---

Mini Flat Packages (mm)			
Optocoupler Version PS29xx, 1.27mm Pitch	4.14	4.7	5.7

NOTES: The Mini Flat package meets the 4.0mm air distance and outer creepage requirement.  
All dimensions are subject to change without notice. Please contact CEL to ensure that you have the latest version of this document.

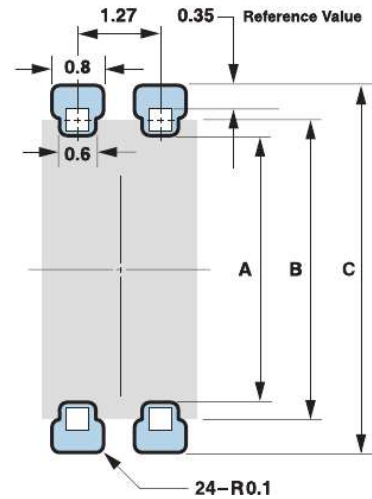

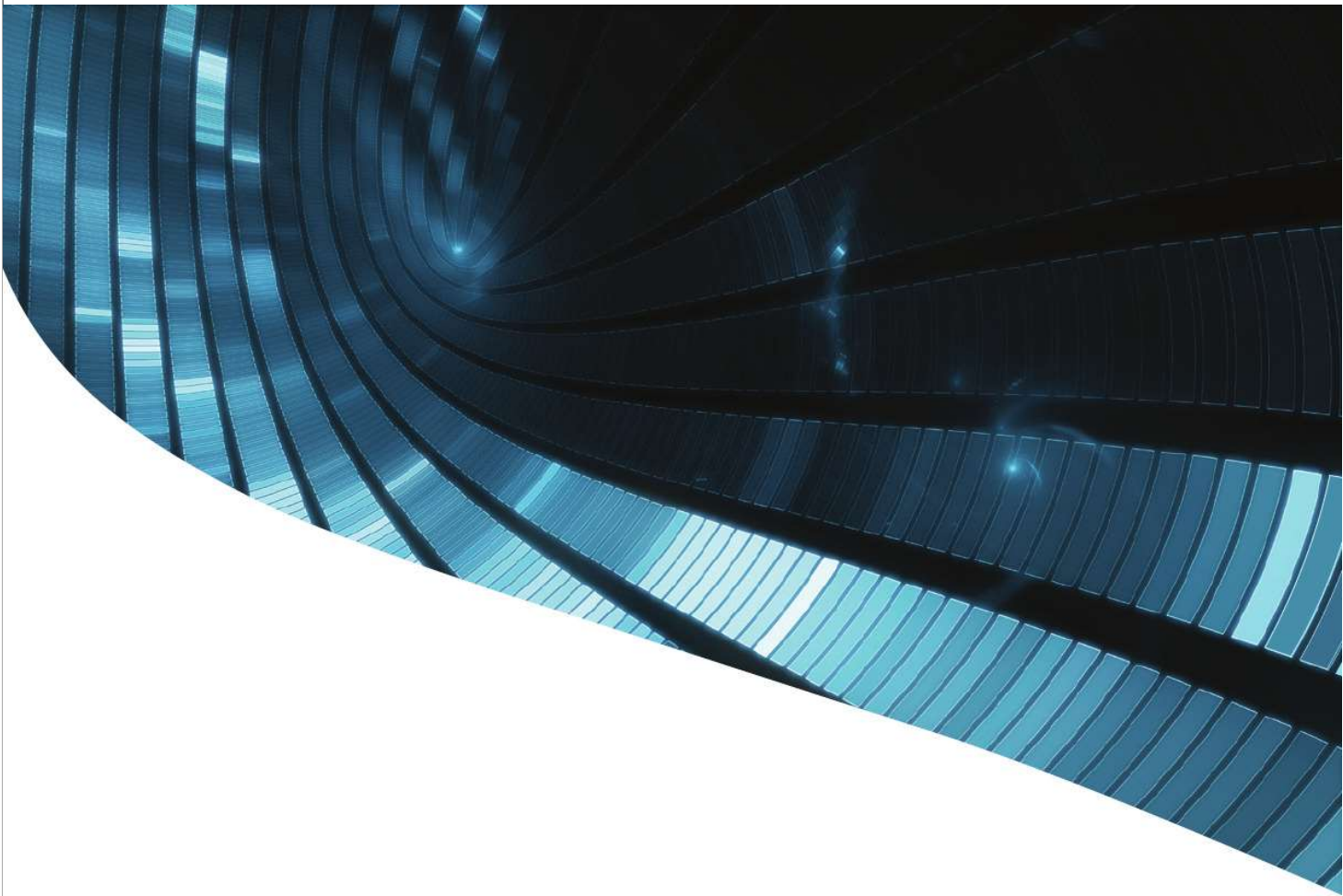

CEL Headquarters

4590 Patrick Henry Drive  
Santa Clara, CA 95054  
Tel: (408) 919-2500  
E-mail: [oc@cel.com](mailto:oc@cel.com)



[Learn more  
www.cel.com/optocouplers](http://www.cel.com/optocouplers)



For a complete list of sales offices, representatives and distributors,  
Please visit our website: [www.cel.com/contactus](http://www.cel.com/contactus)

© 2016 California Eastern Laboratories 07.2016

1-800-344-4635

218-661-3500

[sales@digikoy.com](mailto:sales@digikoy.com)

218-661-3500

800-344-4635



United States | Copyright © 1995-2021, Digi-Key Electronics. | All Rights Reserved.  
Local Support: 701 Brooks Avenue South, Thief River Falls, MN 56701 USA

CA Privacy Rights: Do Not Sell My Personal Information

## Looking for pricing, stock, or lifecycle information?

Click below to explore more details on WIN SOURCE:

 [View PS2915-1-AX on WIN SOURCE](#)

 [CEL Information](#)

## Optimize Your Supply Chain with WIN SOURCE Solutions

-  Global Sourcing Solution
-  Obsolete Management
-  Cost Control Management
-  Shortage Management
-  Alternative Solution
-  Excess Inventory Management