



**THE DATASHEET OF  
LTPL-C08DZS27**





# **LED HIGH POWER**

## **C08 Product Series**

### Data Sheet

Created Date: 03 / 08 / 2013

Revision: 1.4, 05 / 08 / 2013



## LED HIGH POWER C08 Product Series

### 1. Description

The LiteON C08 Product series is a revolutionary, energy efficient and ultra-compact new light source, combining the lifetime and reliability advantages of Light Emitting Diodes with the brightness of conventional lighting. It gives you total design freedom and unmatched brightness, creating a new opportunities for solid state lighting to displace conventional lighting technologies.

#### 1.1 Features

- Compact high flux density light source
- Uniform high quality illumination
- Streamlined thermal path
- MacAdam compliant binning structure  
More energy efficient than incandescent, halogen and fluorescent lamps
- Instant light with unlimited dimming
- RoHS compliant and Pb free
- DC 12V/24V/48V, HV 100V/200V application
- Enhanced optical control
- Clean white light without pixilation
- Uniform consistent white light
- Significantly reduced thermal resistance and increased operating temperatures
- Lower operating costs
- Reduced maintenance costs
- ESD rating is 8KV in HBM

#### 1.2 Available Part Numbers

Nominal CCT	Minimum CRI	Forward Voltage	Part Number
2700K	80	100V	LTPL-C08DZS27
3000K	80	100V	LTPL-C08DZS30
4000K	70	12V	LTPL-C08EXS40
2700K	80	12V	LTPL-C08EZS27
3000K	80	12V	LTPL-C08EZS30
4000K	80	12V	LTPL-C08EZS40
3000K	90	12V	LTPL-C08EQS30

# LED HIGH POWER C08 Product Series

## 2. Outline Dimensions

### 2.1 Form Factor of C08

#### ■ LTPL-C08DXXXX

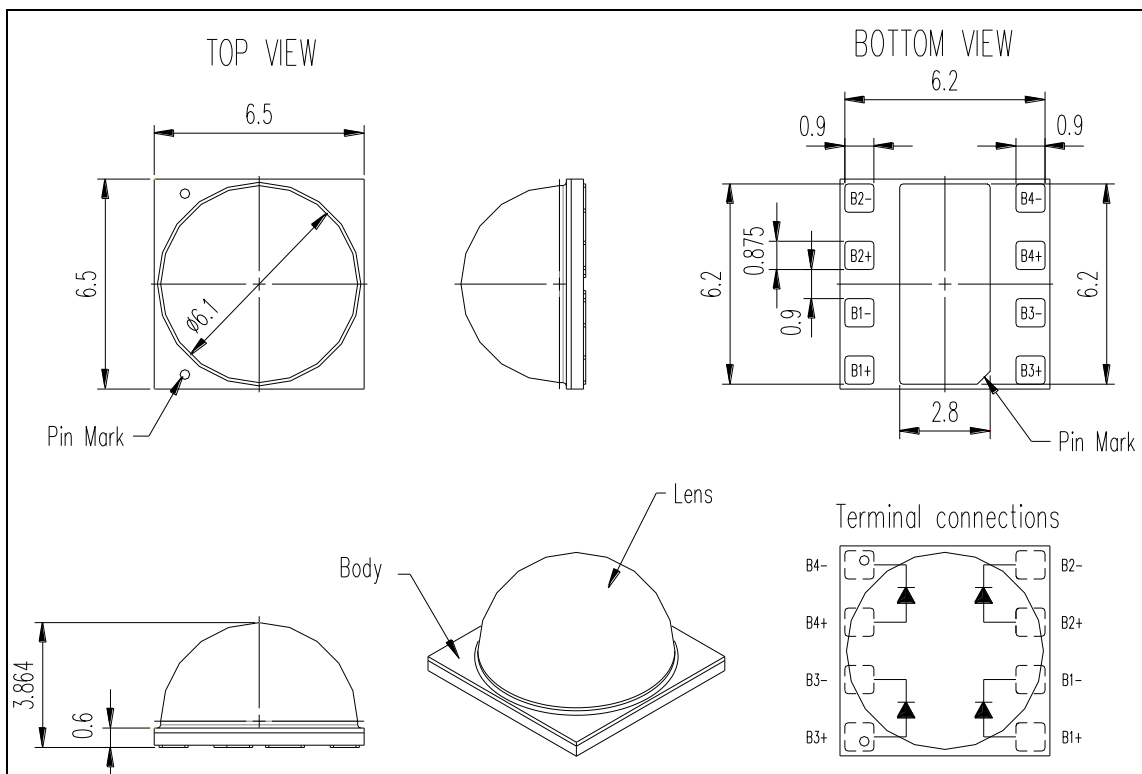

#### ■ LTPL-C08EXXXX

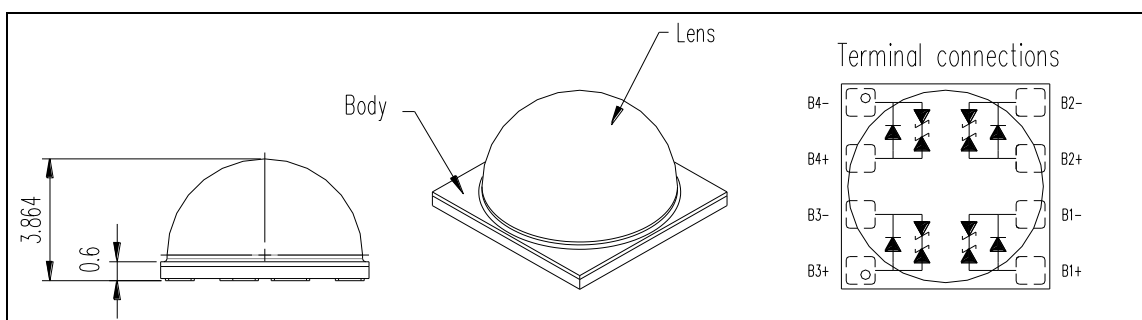

### Notes

1. All dimensions are in millimeters and dimension tolerances are  $\pm 0.2\text{mm}$  except lens height and ceramic length / width dimension tolerance are  $\pm 0.1\text{mm}$ .
2. Thermal pad of the device is electrically neutral from the anode and cathode pads.

## LED HIGH POWER C08 Product Series

### 3. Rating and Characteristics

#### 3.1 Absolute Maximum Ratings at Ta=25°C.

Parameter	Symbol	Rating	Unit
Power Dissipation (100V)	P <sub>o</sub>	6.5	W
Power Dissipation (12V)	P <sub>o</sub>	10	W
DC Forward Current (100V)	I <sub>F</sub>	60	mA
DC Forward Current (12V)	I <sub>F</sub>	720	mA
ESD Sensitivity	V <sub>B</sub>	8	kV
Junction Temperature	T <sub>j</sub>	125	°C
Thermal Resistance, Junction-Case(100V)	R <sub>th, J-C</sub>	4.5	°C / W
Thermal Resistance, Junction-Case (12V)	R <sub>th, J-C</sub>	3.3	°C / W
Operating Temperature Range	T <sub>opr</sub>	-40~+85	°C
Storage Temperature Range	T <sub>stg</sub>	-55~+100	°C

#### Notes

1. The pulse mode condition is 1 KHz with 0.1msec pulse width..
2. Forbid to operating at reverse voltage condition
3. ESD spec is reference to AEC-Q101-001 HBM.
4. The unit of R<sub>th</sub> is °C/W electrical.
5. Thermal resistance measurement tolerance is ± 10%

## LED HIGH POWER C08 Product Series

### 3.2 Electro-Optical Characteristics

#### ■ LTPL-C08DXXXX

Nominal CCT	Minimum CRI	Current (mA)	Typ. VF (V) @25°C	Typ. Flux(lm) @25°C	Typ. VF (V) @85°C	Typ. Flux(lm) @85°C	Eff.(lm/W) @25°C	Eff.(lm/W) @85°C
2700K	80	40	100	360	94	324	90	86
3000K	80	40	100	378	94	340	95	90

#### ■ LTPL-C08EXXXX

Nominal CCT	Minimum CRI	Current (mA)	Typ. VF (V) @25°C	Typ. Flux(lm) @25°C	Typ. VF (V) @85°C	Typ. Flux(lm) @85°C	Eff.(lm/W) @25°C	Eff.(lm/W) @85°C
4000K	70	350	12	567	11.6	510	135	125
2700K	80	350	12	460	11.6	414	110	102
3000K	80	350	12	483	11.6	435	115	107
4000K	80	350	12	506	11.6	455	120	112
3000K	90	350	12	386	11.6	348	92	85

#### Notes

1. All of the VF value are typical and the real bin range please refer page 10 "VF Binning Parameter".
2. All of the Flux value are typical and the real Bin range please refer page 11 "Flux Binning Parameter".
3. Tolerance of Flux is  $\pm 7\%$ , Tolerance of VF is  $\pm 3\%$ , tolerance of CCx/CCy is  $\pm 0.01$ , tolerance of CRI is  $\pm 3$ .
4. LEDs are lighted up and measured with externally parallel connecting leads of LED.
5. Typical viewing angle is 130deg.

## LED HIGH POWER C08 Product Series

### 4. Typical Electrical/Optical Characteristics Curve

#### ■ Efficiency Comparison Table (CRI 80 Series)

##### 4.1 Relative Flux vs. Current of LTPL-C08DXXXX at 25°C

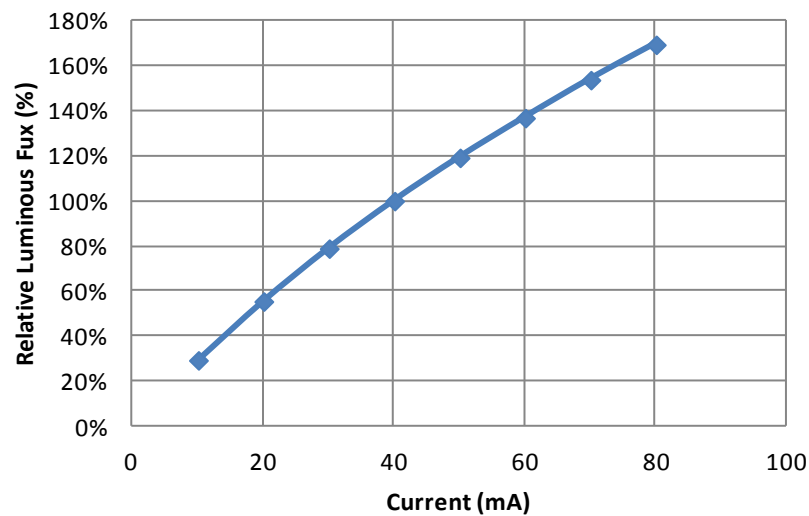

Fig 1. Typical relative luminous flux vs. forward current of LTPL-C08DXXXX

Current	VF	Current	VF	Current	VF	Lumen (lm)	
(mA)	(V)	(mA)	(V)	(mA)	(V)	2700K	3000K
5	192.6	10	96.3	20	48.1	105	111
10	202.4	20	101.2	40	50.6	199	209
15	209.4	30	104.7	60	52.3	284	298
<b>20</b>	<b>214.8</b>	<b>40</b>	<b>107.4</b>	<b>80</b>	<b>53.7</b>	<b>360</b>	<b>378</b>
25	219.8	50	109.9	100	55.0	429	451
30	224.0	60	112.0	120	56.0	493	517

#### Notes

1. Black current-voltage data is gotten by using external parallel connection of 4 strings; deep gray one is by 2 series 2 parallel connection; and gray one is by 4 series connection.
2. The drawing is based on the data of 2 series 2 parallel connection configuration.

## LED HIGH POWER C08 Product Series

### 4.2 Relative Flux vs. Current of LTPL-C08EXXXX at 25°C

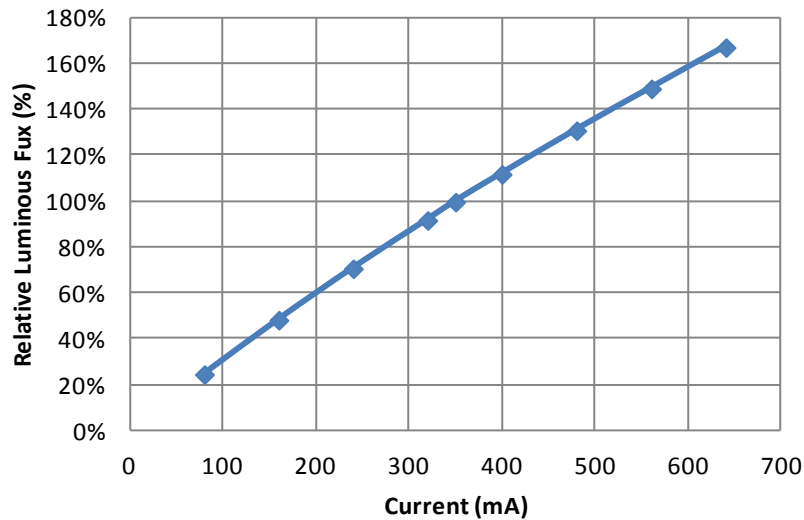

Fig 2. Typical relative luminous flux vs. forward current of LTPL-C08EXXXX

Current	VF	Current	VF	Current	VF	Lumen (lm)		
(mA)	(V)	(mA)	(V)	(mA)	(V)	2700K	3000K	4000K
20	43.0	40	21.5	80	10.7	114	120	126
40	44.3	80	22.2	160	11.1	223	234	248
60	45.5	120	22.7	240	11.4	326	342	362
80	46.4	160	23.2	320	11.6	423	444	470
<b>87.5</b>	<b>46.8</b>	<b>175</b>	<b>23.4</b>	<b>350</b>	<b>11.7</b>	<b>460</b>	<b>483</b>	<b>506</b>
100	47.4	200	23.7	400	11.8	516	541	572
120	48.3	240	24.1	480	12.1	603	634	670
140	49.2	280	24.6	561	12.3	687	722	763
160	50.0	320	25.0	641	12.5	770	809	855

#### Notes

1. Black current-voltage data is gotten by using external parallel connection of 4 strings; deep gray one is by 2 series 2 parallel connection; and gray one is by 4 series connection.
2. The drawing is based on the data of parallel connection configuration.

# LED HIGH POWER C08 Product Series

### 4.3 Relative Spectral Distribution vs. Wavelength Characteristics at 25°C & 85°C

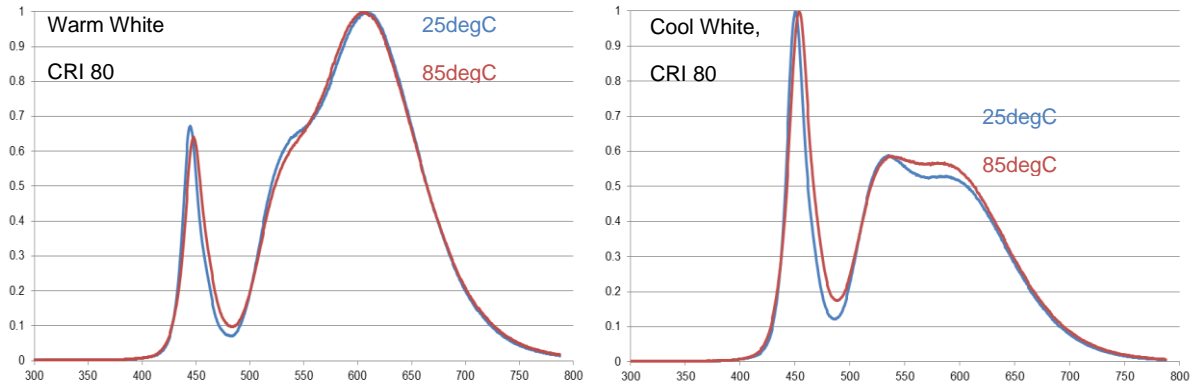

Fig 3. Relative Spectral Distribution at T<sub>j</sub> = 25°C & 85°C

### 4.4 Typical Spatial Radiation Pattern

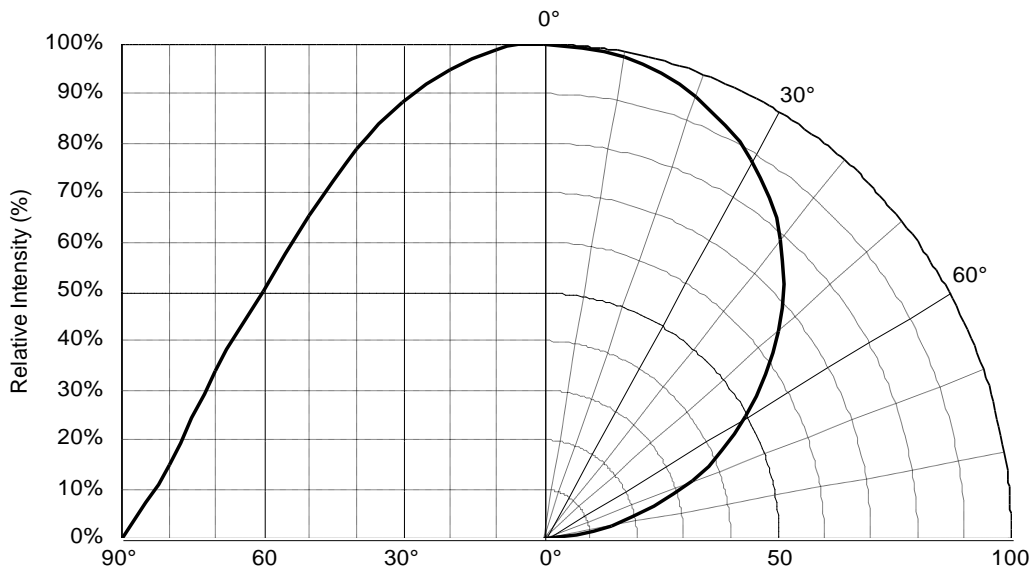

Fig 4. Radiation Characteristics

## LED HIGH POWER C08 Product Series

### 4.5 Forward Current vs. Forward Voltage at 25°C

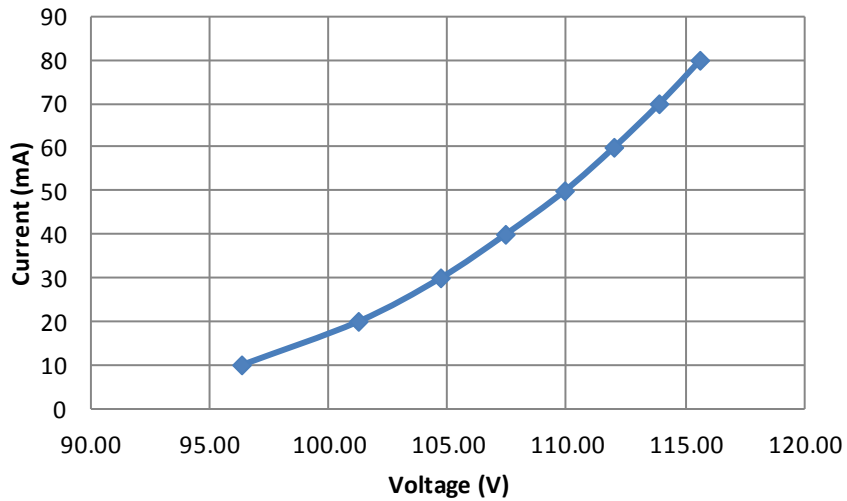

Fig 5. Forward Current vs. Forward Voltage of LTPL-C08DXXXX

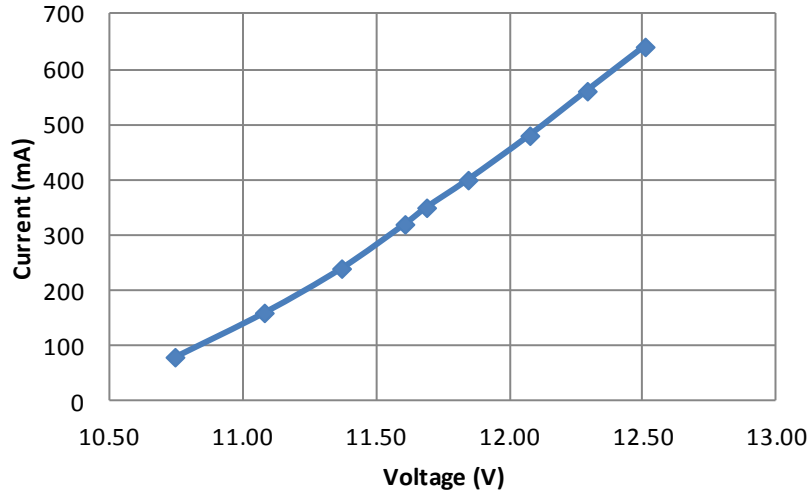

Fig 6. Forward Current vs. Forward Voltage of LTPL-C08EXXXX

## LED HIGH POWER C08 Product Series

### 4.6 Maximum Forward Current vs. Ambient Temperature

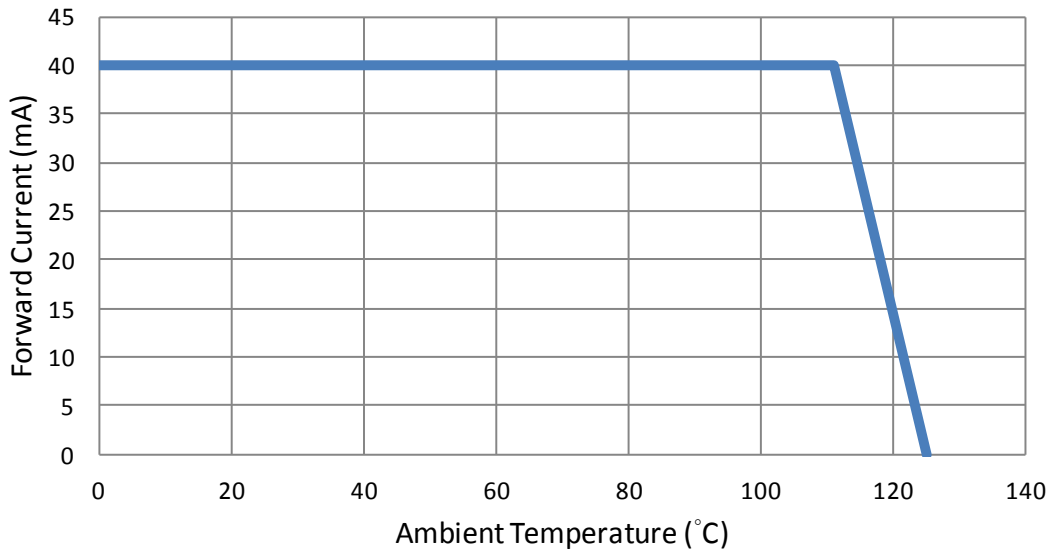

Fig 7. Forward Current Degrading Curve of LTPL-C08DXXXX

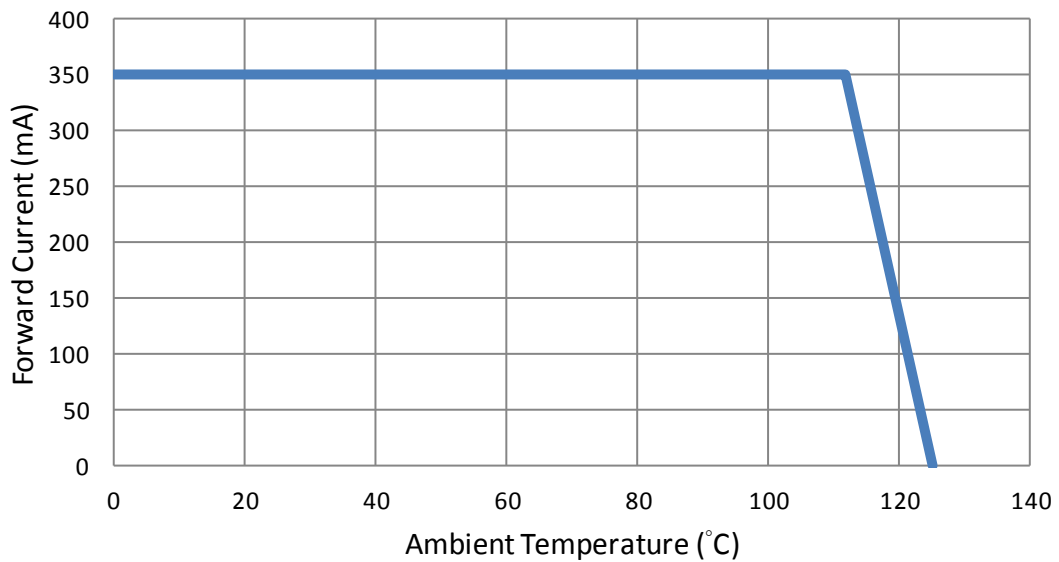

Fig 8. Forward Current Degrading Curve of LTPL-C08EXXXX

## LED HIGH POWER C08 Product Series

### 5. VF Bin Definition

#### 5.1 Forward Voltage Binning Parameter at 25°C

##### ■ LTPL-C08DXXXX

Parameter	Bin	Symbol	Min	Max	Unit	Condition
Forward Voltage	HV1	VF	97	101	V	IF = 40mA
Forward Voltage	HV2	VF	101	105	V	IF = 40mA
Forward Voltage	HV3	VF	105	109	V	IF = 40mA
Forward Voltage	HV4	VF	109	113	V	IF = 40mA

##### ■ LTPL-C08EXXXX

Parameter	Bin	Symbol	Min	Max	Unit	Condition
Forward Voltage	DC1	VF	11	11.3	V	IF = 350mA
Forward Voltage	DC2	VF	11.3	11.7	V	IF = 350mA
Forward Voltage	DC3	VF	11.7	12.1	V	IF = 350mA
Forward Voltage	DC4	VF	12.1	12.6	V	IF = 350mA

## LED HIGH POWER C08 Product Series

### 6. Flux Bin Definition

#### 6.1 Luminous Flux Binning Parameter at 25°C

##### ■ LTPL-C08DXXXX

##### CRI 80 Series

##### 2700K

Parameter	Bin	Symbol	Min	Max	Unit	condition
Luminous Flux	DF	$\Phi V$	315	345	lm	If=40mA
	FH		345	375		
	HJ		375	405		
	JL		405	435		

##### 3000K

Parameter	Bin	Symbol	Min	Max	Unit	condition
Luminous Flux	FH	$\Phi V$	345	375	lm	If=40mA
	HJ		375	405		
	JL		405	435		
	LN		435	465		

##### ■ LTPL-C08EXXXX

##### CRI 80 Series

##### 2700K

Parameter	Bin	Symbol	Min	Max	Unit	condition
Luminous Flux	JL	$\Phi V$	405	435	lm	If=350mA
	LN		435	465		
	NP		465	495		
	PR		495	535		

##### 3000K

Parameter	Bin	Symbol	Min	Max	Unit	condition
Luminous Flux	FH	$\Phi V$	435	465	lm	If=350mA
	HJ		465	495		
	JL		495	535		
	LN		535	575		

## LED HIGH POWER C08 Product Series

### 4000K

Parameter	Bin	Symbol	Min	Max	Unit	condition
Luminous Flux	MO	ΦV	450	480	lm	If=350mA
	OQ		480	515		
	QS		515	555		
	SU		555	600		

### CRI 90 Series

#### 3000K

Parameter	Bin	Symbol	Min	Max	Unit	condition
Luminous Flux	GI	ΦV	360	390	lm	If=350mA
	IK		390	420		
	KM		420	450		

### CRI 70 Series

#### 4000K

Parameter	Bin	Symbol	Min	Max	Unit	condition
Luminous Flux	QS	ΦV	515	555	lm	If=350mA
	SU		555	600		
	UW		600	650		

## LED HIGH POWER C08 Product Series

### 7. Color Bin Definition

#### 7.1 Chromaticity Coordinate Groups at 25°C

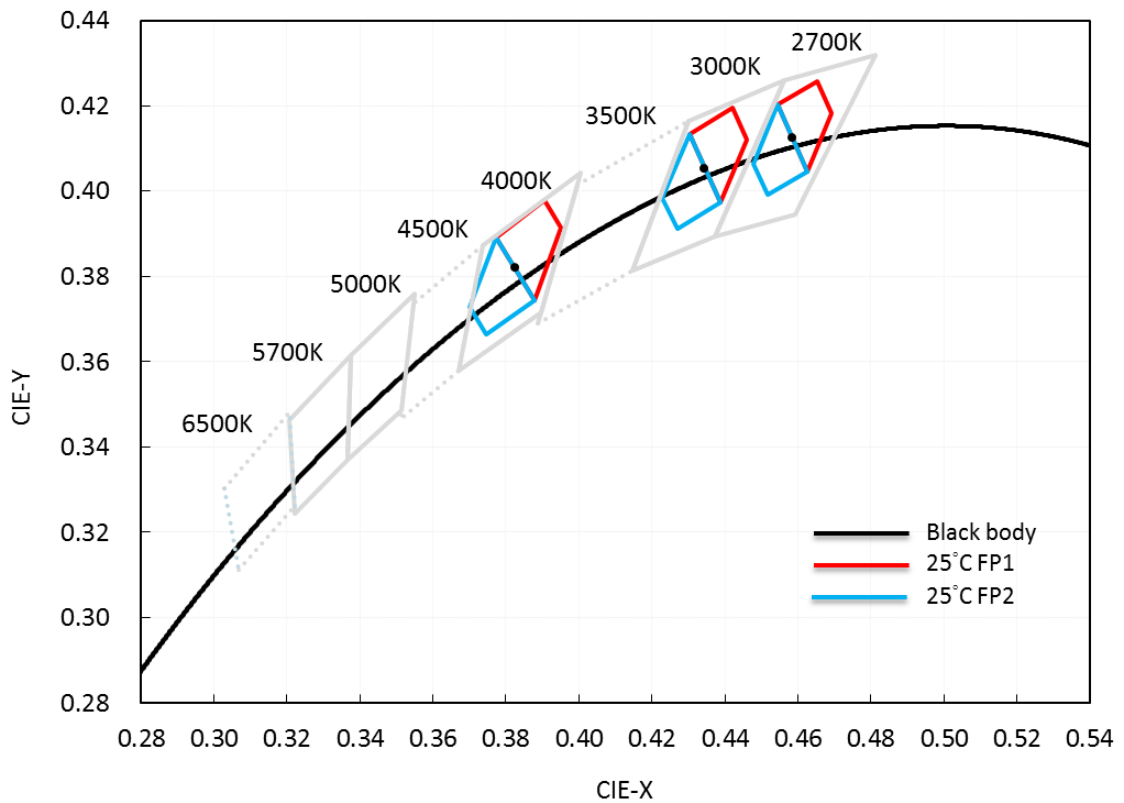

#### Notes

1. The Chromaticity Coordinate Groups follow ANSI 7-Step MacAdam Quadrangle
2. The (CIE<sub>x</sub>, CIE<sub>y</sub>) center follow ANSI Quadrangle

## LED HIGH POWER C08 Product Series

### 7.2 Chromaticity Coordinate Category Code Table at 25°C

#### ■ 2700K Series

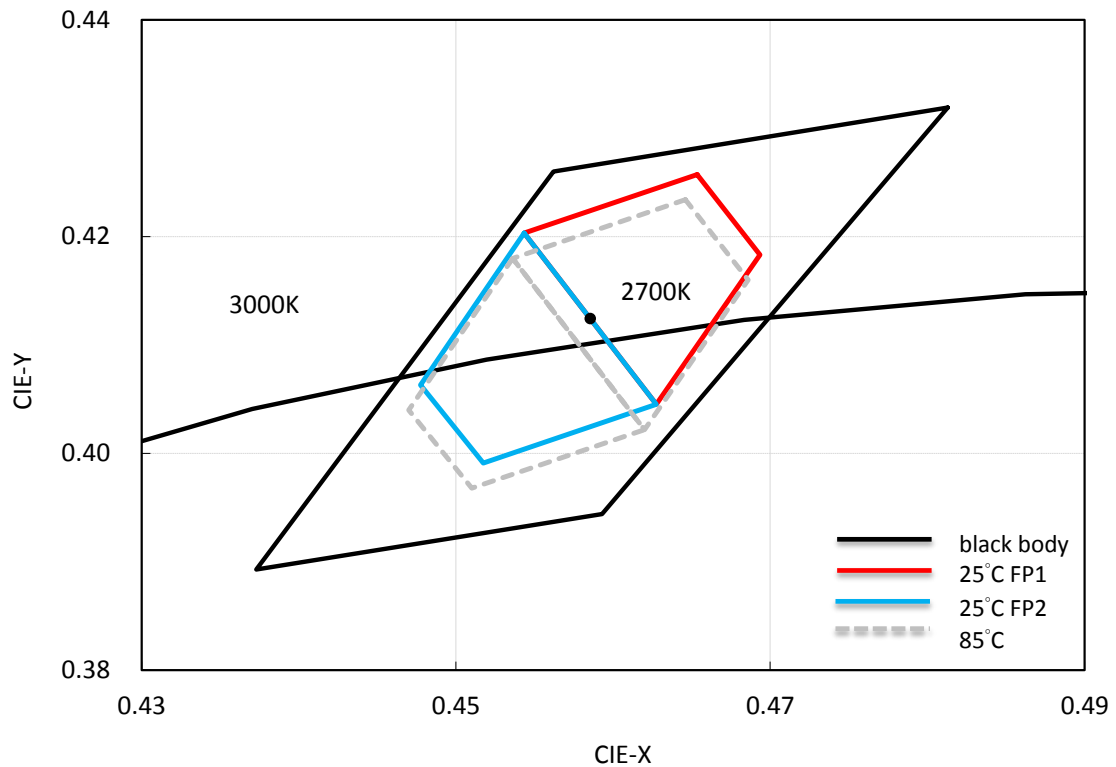

	X	Y
Center point(25C)	0.4585	0.4124
ZCA	0.4653	0.4257
	0.4543	0.4203
	0.4627	0.4045
	0.4693	0.4183
	0.4653	0.4257
ZCB	0.4543	0.4203
	0.4477	0.4063
	0.4517	0.3991
	0.4627	0.4045
	0.4543	0.4203
Center point(85C)	0.4578	0.4101

## LED HIGH POWER C08 Product Series

### ■ 3000K Series

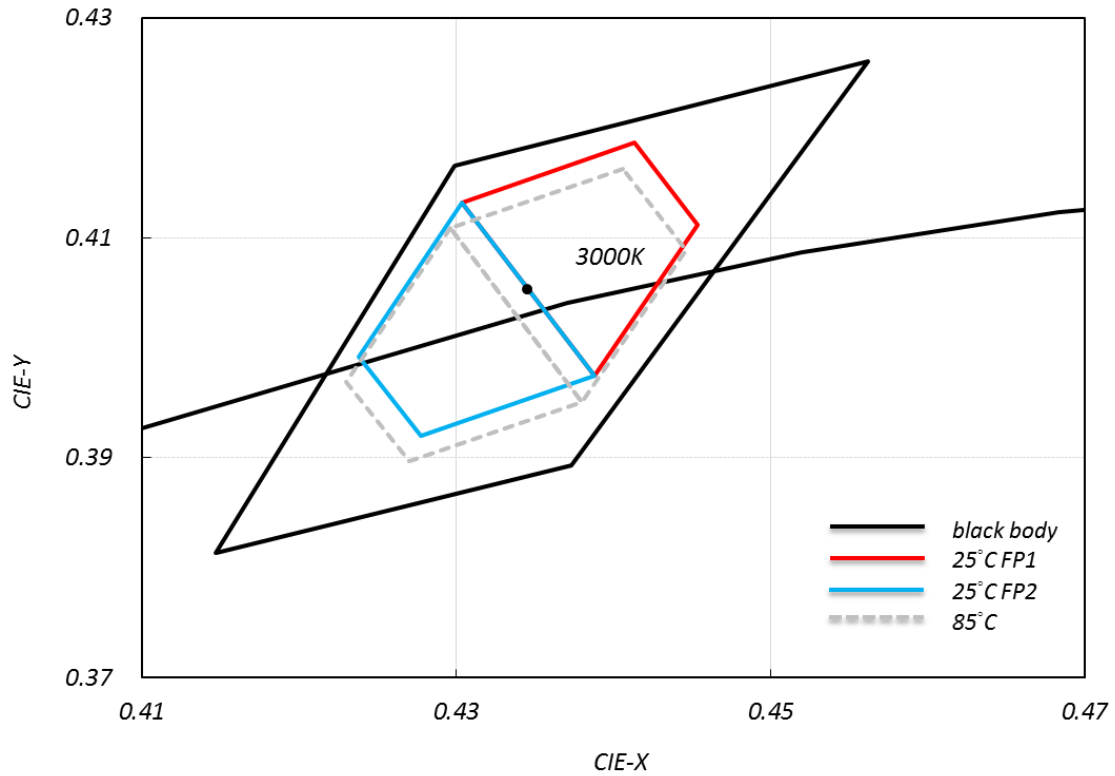

	X	Y
Center point(25C)	0.4345	0.4053
ZDA/QDA	0.4413	0.4186
	0.4303	0.4132
	0.4387	0.3974
	0.4453	0.4112
	0.4413	0.4186
ZDB/QDB	0.4303	0.4132
	0.4237	0.3992
	0.4277	0.3920
	0.4387	0.3974
	0.4303	0.4132
Center point(85C)	0.4338	0.4030

# LED HIGH POWER C08 Product Series

■ 4000K Series

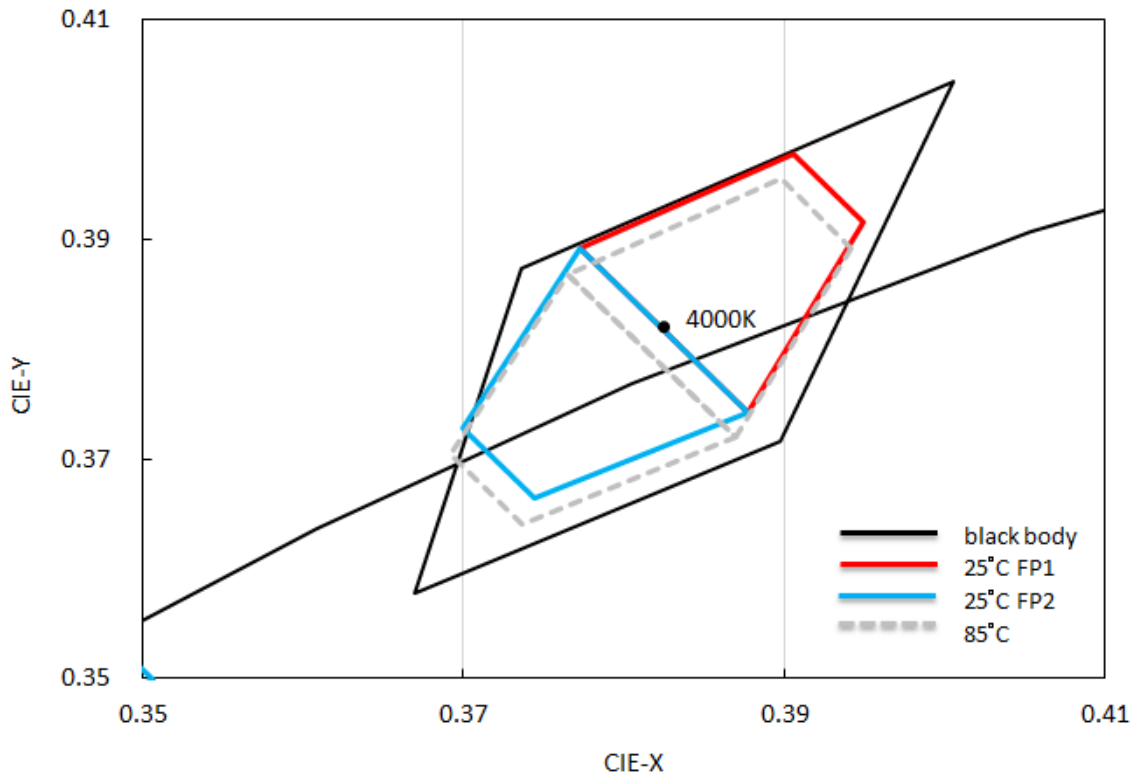

	X	Y
Center point(25C)	0.3825	0.3820
ZFA/XFA	0.3949	0.3915
	0.3905	0.3978
	0.3772	0.3891
	0.3877	0.3743
	0.3949	0.3915
ZFB/XFB	0.3877	0.3743
	0.3744	0.3664
	0.3699	0.3728
	0.3772	0.3891
	0.3877	0.3743
Center point(85C)	0.3818	0.3797

## LED HIGH POWER C08 Product Series

### 8. Reflow Soldering Characteristics

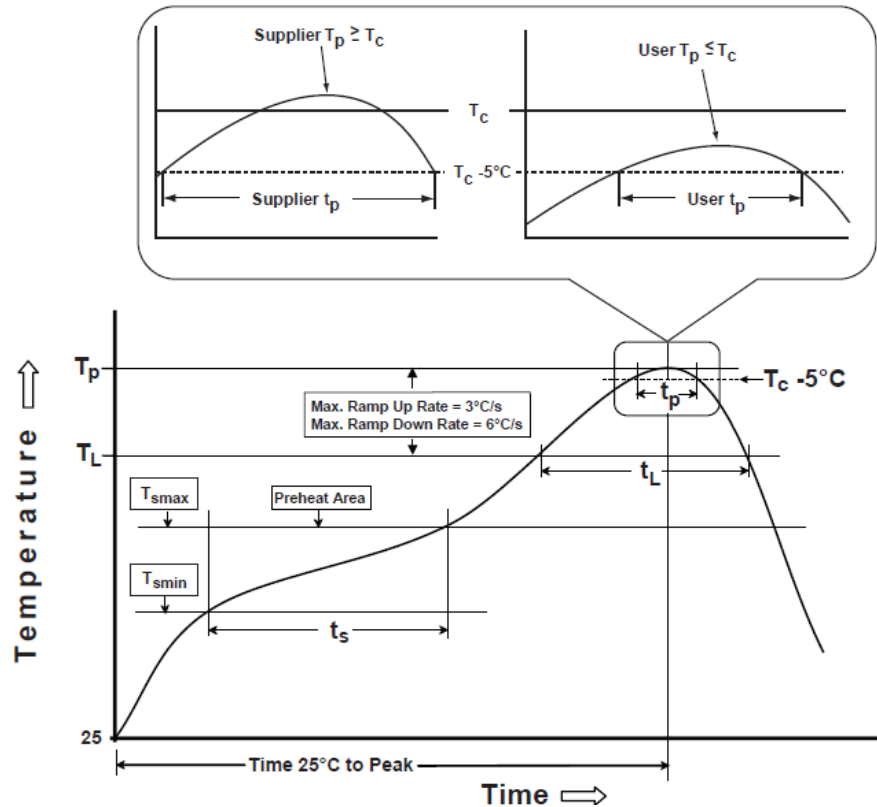

Profile Feature	Lead Free Assembly
Average Ramp-Up Rate ( $T_{smax}$ to $T_p$ )	3°C / second max
Preheat Temperature Min ( $T_{smin}$ )	150°C
Preheat Temperature Max ( $T_{smax}$ )	200°C
Preheat Time ( $t_{smin}$ to $t_{smax}$ )	60 – 180 seconds
Time Maintained Above Temperature ( $T_L$ )	217°C
Time Maintained Above Time ( $t_L$ )	60 – 150 seconds
Peak / Classification Temperature ( $T_p$ )	255°C
Time Within 5°C of Actual Peak Temperature ( $t_p$ )	5 seconds
Ramp – Down Rate	6°C / second max
Time 25°C to Peak Temperature	8 minutes max

## LED HIGH POWER C08 Product Series

### Notes:

1. The LEDs can be soldered using the reflow soldering or hand soldering method. The recommended hand soldering condition is 350°C max. and 2secs max. for one time only, and the recommended reflow soldering condition is 260°C max. and 5secs max. for three times max.
2. All temperatures refer to topside of the package, measured on the package body surface.
3. The soldering condition referring to J-STD-020B. The storage ambient for the LEDs should not exceed 30°C temperature or 70% relative humidity. It is recommended that LEDs out of their original packaging are soldered within one week. For extended storage out of their original packaging, it is recommended that the LEDs were stored in a sealed container with appropriate desiccant, or desiccators with nitrogen ambient. If the LEDs were unpacked more than 168hrs, baking the LEDs at 60°C for 60 mins before soldering process.
4. The soldering profile could be further referred to different soldering grease material characteristic. The grease vendor will provide this information.
5. A rapid-rate process is not recommended for the LEDs cooling down from the peak temperature.
6. Although the recommended reflow conditions are specified above, the reflow or hand soldering condition at the lowest possible temperature is desirable for the LEDs.
7. LiteOn cannot make a guarantee on the LEDs which have been already assembled using the dip soldering method.

## LED HIGH POWER C08 Product Series

### 9. Reliability Test Plan

#### ■ LTPL-C08DXXXX

No	Test item	Condition	Duration	Number of Failed
1	High Temperature Operating Life (HTOL)	Tc=105°C, IF=40mA DC (0, 250, 500, 750, 1000hrs)	1K hrs	0/20
2	High Temperature Operating Life (HTOL)	Tc=85°C, IF=40mA DC (0, 250, 500, 750, 1000hrs)	1K hrs	0/20
3	Room Temperature Operating Life (RTOL)	Tc=55°C, IF=40mA DC (0, 250, 500, 750, 1000hrs)	1K hrs	0/20
4	Wet High Temperature Operating (WHTOL)	85°C/85%RH, IF=40mA DC 30 min ON/OFF	1K hrs	0/20
5	Power Temperature Cycle (PTMCL)	-40°C to 105°C 15minutes dwell/15minutes transfer 5 minutes ON/5 minutes OFF IF=40mA DC	1K cycles	0/20
6	Non-Operating Thermal Shock (TMSK)	-40°C to 125°C 30minutes dwell, <10 seconds transfer measure each 250 cycles (continues to fail, more than 1k cycles)	1K cycles	0/20
7	Fast switch Cycling Test	40000cycles, 2 mins On/Off, Room temperature(25°C+/-5°C), measurement in every 5000cycles	40K cycles	0/20

#### Notes:

1. Operating life test are mounted on thermal heat sink
2. Storage item are only component, not put on heat sink.

Criteria for Judging the Damage

Item	Symbol	Test Condition	Criteria for Judgment	
			Min.	Max.
Forward Voltage	Vf	IF=Typical Current	-10%	+10%
Luminous Flux	Lm	IF=Typical Current	-15%	+15%

## LED HIGH POWER C08 Product Series

CCX&CCY	X,Y	IF=Typical Current	-0.007	+0.007
---------	-----	--------------------	--------	--------

### ■ LTPL-C08EXXXX

No	Test item	Condition	Duration	Number of Failed
1	High Temperature Operating Life (HTOL)	Tc=105°C, IF=350mA DC (0, 250, 500, 750, 1000hrs)	1K hrs	0/20
2	High Temperature Operating Life (HTOL)	Tc=85°C, IF=350mA DC (0, 250, 500, 750, 1000hrs)	1K hrs	0/20
3	Room Temperature Operating Life (RTOL)	Tc=55°C, IF=350mA DC (0, 250, 500, 750, 1000hrs)	1K hrs	0/20
4	Wet High Temperature Operating (WHTOL)	85°C/85%RH, IF=350mA DC 30 min ON/OFF	1K hrs	0/20
5	Power Temperature Cycle (PTMCL)	-40°C to 105°C 15minutes dwell/15minutes transfer 5 minutes ON/5 minutes OFF IF=350mA DC	1K cycles	0/20
6	Non-Operating Thermal Shock (TMSK)	-40°C to 125°C 30minutes dwell, <10 seconds transfer measure each 250 cycles (continues to fail, more than 1k cycles)	1K cycles	0/20
7	Fast switch Cycling Test	40000cycles, 2 mins On/Off, Room temperature(25°C+/-5°C), measurement in every 5000cycles	40K cycles	0/20

### Notes:

- Operating life test are mounted on thermal heat sink
- Storage item are only component, not put on heat sink.

Criteria for Judging the Damage

Item	Symbol	Test Condition	Criteria for Judgment	
			Min.	Max.
Forward Voltage	Vf	IF=Typical Current	-10%	+10%
Luminous Flux	Lm	IF=Typical Current	-15%	+15%

## LED HIGH POWER C08 Product Series

CCX&CCY	X,Y	IF=Typical Current	-0.007	+0.007
---------	-----	--------------------	--------	--------

### 10. Recommend Soldering Pad Layout

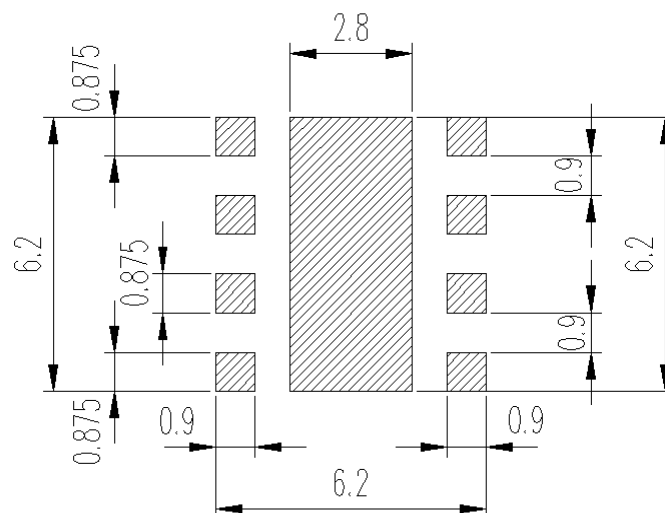
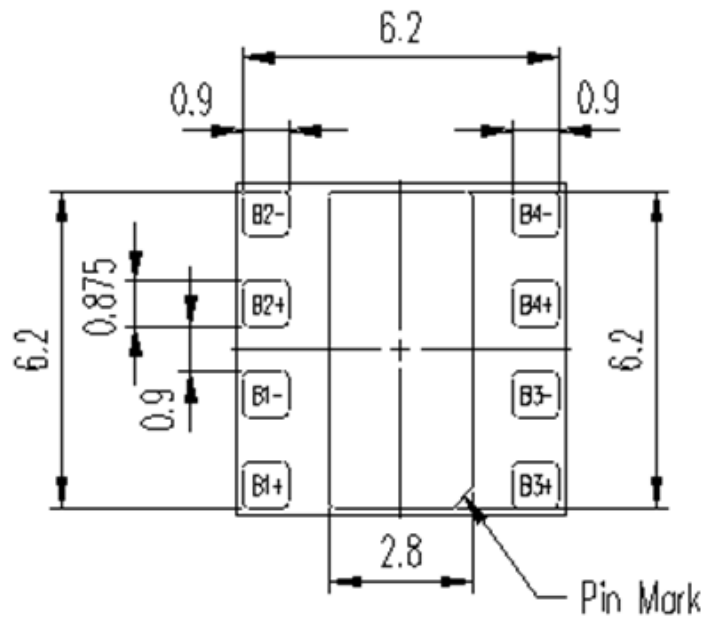

#### Notes:

1. Suggest stencil thickness is maximum 0.10mm

---

**LED HIGH POWER  
C08 Product Series**

# LED HIGH POWER C08 Product Series

## 11. Package Dimensions of Tape and Reel

### Reel Packaging

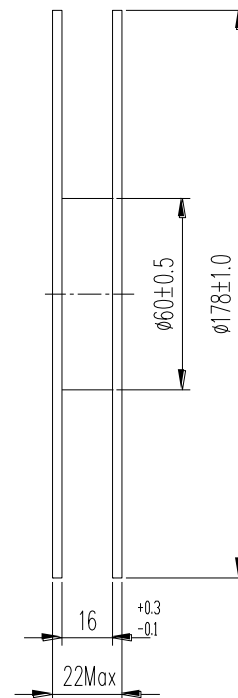
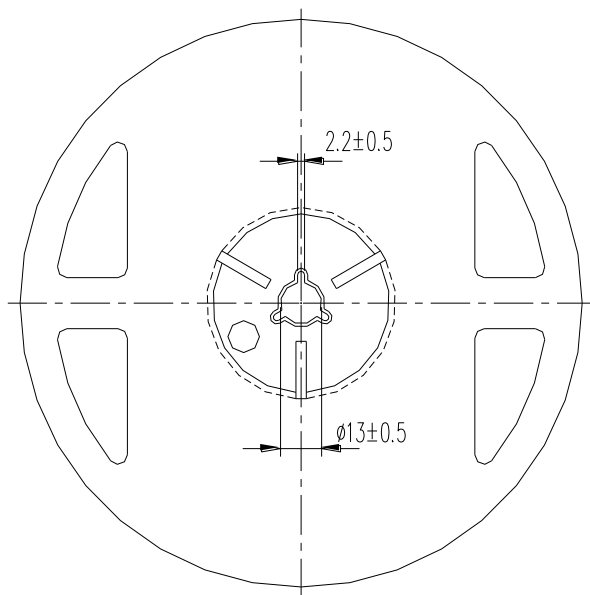

Note: The tolerances unless mentioned is  $\pm 0.1$ mm, Unit=mm

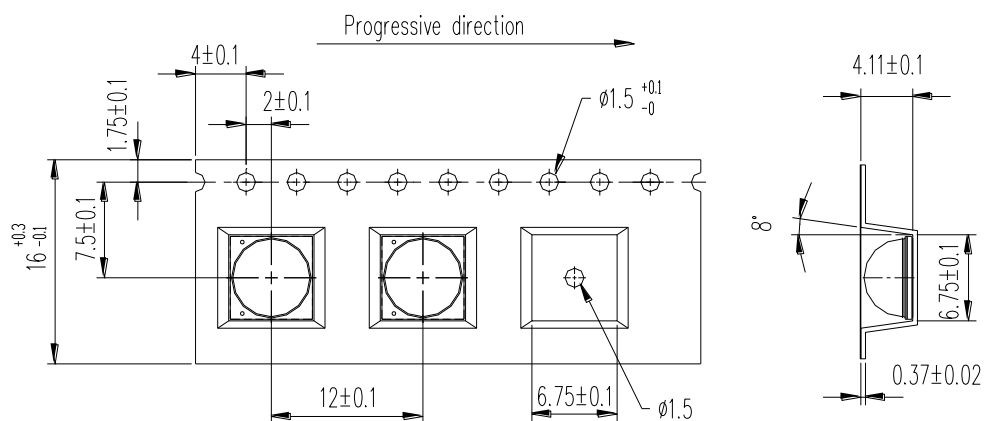

### Note:

1. All dimensions are in millimeters.
2. Empty component pockets sealed with top cover tape.

## LED HIGH POWER C08 Product Series

### 12. Cautions

**12.1** An LED is a current-operated device. In order to ensure intensity uniformity on multiple LEDs connected in parallel in an application, it is recommended that a current limiting resistor be incorporated in the drive circuit, in series with each LED as shown in Circuit below.

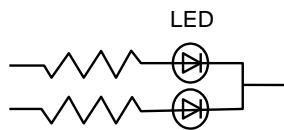

Circuit model A

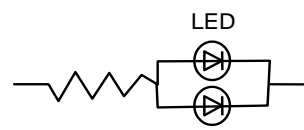

Circuit model B

(A) Recommended circuit.

(B) The brightness of each LED might appear different due to the differences in the I-V characteristics of those LEDs.

**12.2** Do not put any pressure on the light emitting surface either by finger or any hand tool and do not stack the COB products. Stress or pressure may cause damage to the wires of the LED array.

**12.3** This product is not designed for the use under any of the following conditions, please confirm the performance and reliability are well enough if you use it under any of the following conditions

- Do not use sulfur-containing materials in commercial products including the materials such as seals and adhesives that may contain sulfur.
- Do not put this product in a place with a lot of moisture (over 85% relative humidity), dew condensation, briny air, and corrosive gas (Cl, H<sub>2</sub>S, NH<sub>3</sub>, SO<sub>2</sub>, NO<sub>x</sub>, etc.), exposure to a corrosive environment may affect silver plating.

### ESD (Electrostatic Discharge)

Static Electricity or power surge will damage the LED. Suggestions to prevent ESD damage:

- Use of a conductive wrist band or anti-electrostatic glove when handling these LEDs.
- All devices, equipment, and machinery must be properly grounded.
- Work tables, storage racks, etc. should be properly grounded.
- Use ion blower to neutralize the static charge which might have built up on surface of the LED's plastic lens as a result of friction between LEDs during storage and handling.

ESD-damaged LEDs will exhibit abnormal characteristics such as high reverse leakage current, low forward voltage, or "no light up" at low currents.

To verify for ESD damage, check for "light up" and VF of the suspect LEDs at low currents.

## LED HIGH POWER C08 Product Series

### ■ Lens Handling Remark

The LED should only be picked up by making contact with the sides of the LED body. It should not put any pressure on the lens either by finger or any hand tool. Do not puncture or push the lens. Below figure illustrate correct and incorrect handling.

### ■ Storage

The storage ambient for the LEDs should not exceed 30°C temperature or 85% relative humidity.

## 13. Recommended Circuit Application

### 13.1 LTPL-C08ExSxx

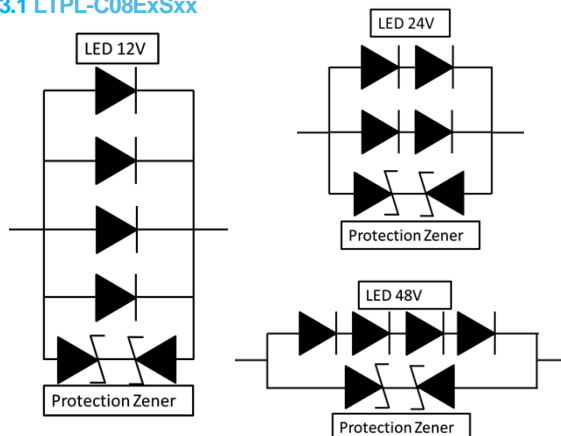

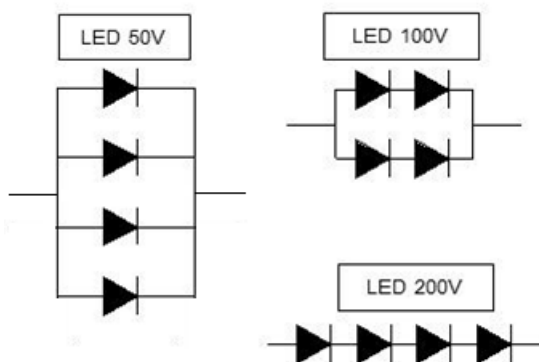

### 13.2 LTPL-C08DxSxx



## Looking for pricing, stock, or lifecycle information?

Click below to explore more details on WIN SOURCE:

-  [View LTPL-C08DZS27 on WIN SOURCE](#)
-  [Lite-On Inc. Information](#)

## Optimize Your Supply Chain with WIN SOURCE Solutions

-  Global Sourcing Solution
-  Obsolete Management
-  Cost Control Management
-  Shortage Management
-  Alternative Solution
-  Excess Inventory Management