



# THE DATASHEET OF DS276S+



### FEATURES

- Low-power serial transmitter/receiver for battery-backed systems
- Transmitter steals power from receive signal line to save power
- Single 3V or 5V operation
- Full duplex operation up to 20k bps
- Ultra-low static current
- Compatible with RS-232-E signals

### PIN ASSIGNMENT

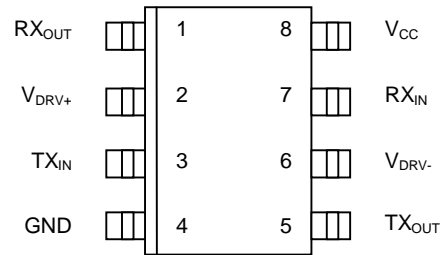

DS276 8-Pin DIP (300-mil)  
DS 276S 8-Pin SOIC (150-mil)

### PIN DESCRIPTION

RX <sub>OUT</sub>	RS-232 Receiver Output
V <sub>DRV+</sub>	Transmit Driver Positive Supply
TX <sub>IN</sub>	RS-232 Driver Input
GND	System Ground (0V)
TX <sub>OUT</sub>	RS-232 Driver Output
V <sub>DRV-</sub>	Transmit Driver Negative Supply
RX <sub>IN</sub>	RS-232 Receiver Input
V <sub>CC</sub>	System Logic Supply (3-5V)

### ORDERING INFORMATION

DS276	8-Pin DIP
DS276S	8-Pin SOIC

### DESCRIPTION

The DS276 Line-Powered RS-232 Transceiver Chip is a CMOS device that provides a low-cost, very low-power interface to RS-232 serial ports. The receiver input translates RS-232 signal levels to common CMOS/TTL levels. The transmitter can be used with independently supplied positive and negative supplies, but in most cases will be used with the positive supply, sharing the logic supply and the negative supply stolen from the receive RS-232 signal when that signal is in a negative state (marking). By using an external reservoir capacitor and Schottky diode (see Figure 4) this negative supply can be maintained even during full-duplex operation. Since most serial communication ports remain in a negative state statically, using the receive signal for negative power greatly reduces the DS276's static power consumption. This feature is especially important for battery-powered systems such as laptop computers, remote sensors, and portable medical instruments. During an actual communication session, the DS276's transmitter will use system power (3-12 volts) for positive transitions while still employing the receive signal for negative transitions.

## OPERATION

Designed for the unique requirements of battery-backed systems, the DS276 provides a low-power full-or half-duplex interface to an RS-232 serial port. Typically, a designer must use an RS-232 device which uses system power during both negative and positive transitions of the transmit signal to the RS-232 port. If the connector to the RS-232 port is left connected for an appreciable time after the communication session has ended, power will statically flow into that port, draining the battery capacity. The DS276 eliminates this static current drain by stealing current from the receive line (RX<sub>IN</sub>) of the RS-232 port when that line is at a negative level (marking). Since most asynchronous communication over an RS-232 connection typically remains in a marking state when data is not being sent, the DS276 will not consume system power in this condition. System power would only be used when positive-going transitions are needed on the transmit RS-232 output (TX<sub>OUT</sub>) when data is sent. However, since synchronous communication sessions typically exhibit a very low duty-cycle, overall system power consumption remains low.

## RECEIVER SECTION

The RX<sub>IN</sub> pin is the receive input for an RS-232 signal whose levels can range from  $\pm 3$  to  $\pm 15$  volts. A negative data signal is called a mark while a positive data signal is called a space. These signals are inverted and then level-shifted to normal +3 or +5 volt CMOS/TTL logic levels. The logic output associated with RX<sub>IN</sub> is RX<sub>OUT</sub> which swings from V<sub>CC</sub> to ground. Therefore, a mark on RX<sub>IN</sub> produces a logic 1 at RX<sub>OUT</sub>; a space produces a logic 0.

The input threshold of RX<sub>IN</sub> is typically around 1.8 volts with 500 millivolts of hysteresis to improve noise rejection. Therefore, an input positive-going signal must exceed 1.8 volts to cause RX<sub>OUT</sub> to switch states. A negative-going signal must now be lower than 1.3 volts (typically) to cause RX<sub>OUT</sub> to switch again. An open on RX<sub>IN</sub> is interpreted as a mark, producing a logic 1 at RX<sub>OUT</sub>.

## TRANSMITTER SECTION

TX<sub>IN</sub> is the CMOS/TTL-compatible input for data from the user system. A logic 1 at TX<sub>IN</sub> produces a mark (negative data signal) at TX<sub>OUT</sub> while a logic 0 produces a space (positive data signal). As mentioned earlier, the transmitter section employs a unique driver design that can use the RX<sub>IN</sub> line for swinging to negative levels. RX<sub>IN</sub> can be connected via external circuitry to V<sub>DRV-</sub> to allow stored charge to supply this voltage during marking (or idle) states. When TX<sub>OUT</sub> needs to transition to a positive level, it uses the V<sub>DRV+</sub> power pin for this level. V<sub>DRV+</sub> can be a voltage supply between 3 to 12 volts, and in many situations it can be tied directly to the V<sub>CC</sub> supply. It is important to note that V<sub>DRV+</sub> must be greater than or equal to V<sub>CC</sub> at all times.

The voltage range on V<sub>DRV+</sub> permits the use of a 9V battery in order to provide a higher voltage level when TX<sub>OUT</sub> is in a space state. When V<sub>CC</sub> is shut off to the DS276 and V<sub>DRV+</sub> is still powered (as might happen in a battery-backed condition), only a small leakage current (about 50-100 nA) will be drawn. If TX<sub>OUT</sub> is loaded during such a condition, V<sub>DRV+</sub> will draw current only if RX<sub>IN</sub> is not in a negative state. During normal operation (V<sub>CC</sub> = 3 or 5 volts), V<sub>DRV+</sub> will draw less than 2  $\mu$ A when TX<sub>OUT</sub> is marking. Of course, when TX<sub>OUT</sub> is spacing, V<sub>DRV+</sub> will draw substantially more current—about 3 mA, depending upon its voltage and the impedance that TX<sub>OUT</sub> sees. The TX<sub>OUT</sub> output is slew rate-limited to less than 30 volts/ $\mu$ s in accordance with RS-232 specifications. In the event TX<sub>OUT</sub> should be inadvertently shorted to ground, internal current-limiting circuitry prevents damage, even if continuously shorted.

## RS-232 COMPATIBILITY

The intent of the DS276 is not so much to meet all the requirements of the RS-232 specification as to offer a low-power solution that will work with most RS-232 ports with a connector length of less than 10

feet. As a prime example, the DS276 will not meet the RS-232 requirement that the signal levels be at least  $\pm 5$  volts minimum when terminated by a 3 k $\Omega$  load and  $V_{DRV+} = +3-5$  volts. Typically 2.5 to 4 volts will be present at TX<sub>OUT</sub> when spacing under this condition, depending on the supply voltage. However, since most RS-232 receivers will correctly interpret any voltage over 2 volts as a space, there will be no problem transmitting data.

## DS276 BLOCK DIAGRAM Figure 1

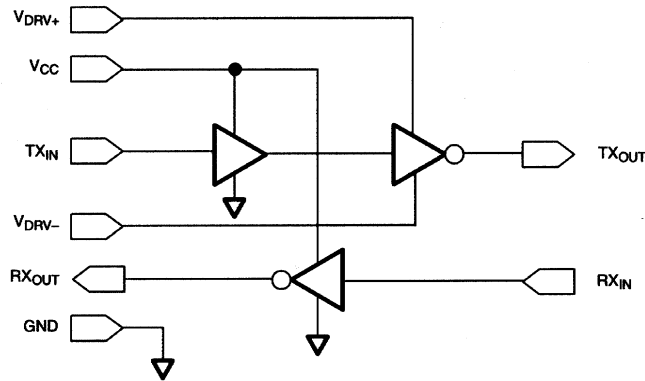

## APPLICATIONS INFORMATION

The DS276 is designed as a low-cost, RS-232-E interface expressly tailored for the unique requirements of battery-operated handheld products. As shown in the electrical specifications, the DS276 draws exceptionally low operating and static current. During normal operation when data from the handheld system is sent from the TX<sub>OUT</sub> output, the DS276 only draws significant  $V_{DRV+}$  current when TX<sub>OUT</sub> transitions positively (spacing). This current flows primarily into the RS-232 receiver's 3-7 k $\Omega$  load at the other end of the attaching cable. When TX<sub>OUT</sub> is marking (a negative data signal), the  $V_{DRV+}$  current falls dramatically since the negative voltage is provided by the transmit signal from the other end of the cable. This represents a large reduction in overall operating current, since typical RS-232 interface chips use charge-pump circuits to establish both positive and negative levels at the transmit driver output. To obtain the lowest power consumption from the DS276, observe the following guidelines: First, to minimize  $V_{DRV+}$  current when connected to an RS-232 port, always maintain TX<sub>IN</sub> at a logic 1 when data is not being transmitted (idle state). This will force TX<sub>OUT</sub> into the marking state, minimizing  $V_{DRV+}$  current. Second,  $V_{DRV+}$  current will drop significantly when  $V_{CC}$  is grounded. Therefore, if  $V_{DRV+}$  is derived independently from  $V_{CC}$  (for example connected to a 9V battery), the logic supply voltage can be turned off to achieve the lowest possible power state.

## FULL-DUPLEX OPERATION

The DS276 is intended for full-duplex operation using the full-duplex circuit shown in Figure 4 to generate a negative rail from RX<sub>IN</sub>. The 22  $\mu$ F capacitor forms a negative-charge reservoir; consequently, when the TXD line RX<sub>IN</sub> is spacing (positive), TX<sub>OUT</sub> still has a negative source available for a time period determined by the capacitor and the load resistance at the other end (3-7 k $\Omega$ ).

## SUPPLY VOLTAGE OPTIONS

The DS276 is intended primarily for use in single supply 3- or 5- volts systems. However, several supply configurations are possible.

## 3V OPERATION

The simplest configuration is to use a single 3V supply for  $V_{CC}$  and  $V_{drv+}$ , and connect  $V_{drv-}$  to ground. This will result in the lowest power consumption and will give adequate serial communication between

two similar devices over short distances, and into larger loads than the 3 kΩ RS-232 standard (Figure 2). If  $V_{drv+}$  is increased to 5V, and  $V_{drv-}$  decreased (to less than -2V) communication with standard RS-232 devices is possible, although of course the output voltage swing of the DS276 remains below the RS-232 specification. The  $V_{drv-}$  supply can be derived using the “stealing” technique shown in Figure 4.

### 5V OPERATION

The use of a single 5V supply for  $V_{CC}$  and  $V_{drv+}$ , and  $V_{drv-}$  derived using the circuit in Figure 4 can produce reliable communication with standard RS-232 devices, although the DS276 output voltage swings are below the RS-232 minimum (Figure 3).

Increasing the magnitude of the voltage to  $V_{drv+}$  to 10 volts or more will result in “true” RS-232 output voltage levels.

### SINGLE 3V OPERATION Figure 2

(See Note 3)

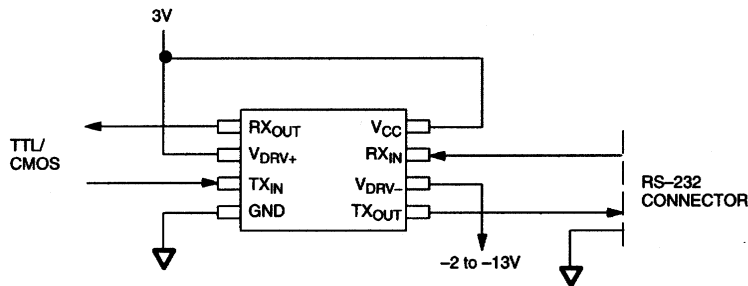

### SINGLE 5V OPERATION Figure 3 (not true RS-232)

(See Note 1 and 3)

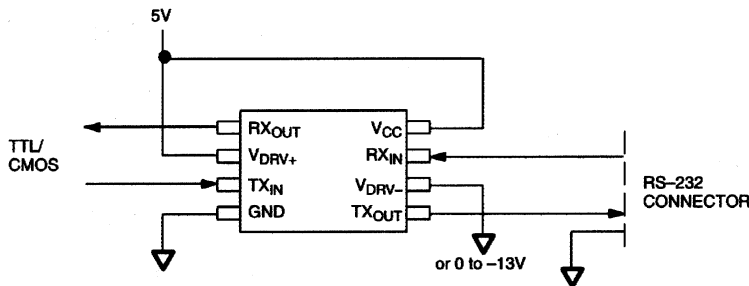

### "STEALING" NEGATIVE SUPPLY Figure 4

(See Note 2)

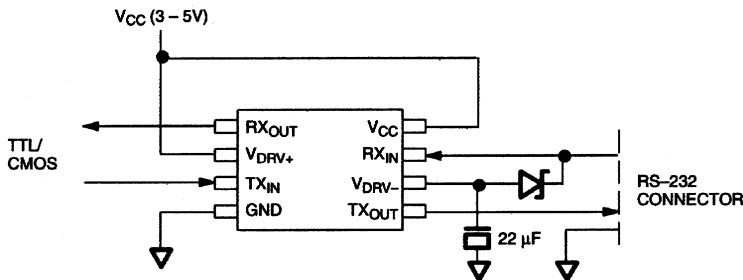

**NOTES:**

1. This circuit as shown does not meet the RS-232 requirement for signal levels (high-level output voltage). However, as most RS-232 receivers will interpret any voltage over 2V as a space this will normally be of no consequence. Alternatively,  $V_{DRV+}$  can be supplied independently from a higher voltage supply.
2. The capacitor is charged negatively whenever  $RX_{IN}$  is in a marking (or idle) state. When the DS276 is transmitting marking data and  $RX_{IN}$  is spacing the capacitor will discharge towards ground with a time constant determined by the capacitor value and the value of the load resistance. The value shown should store sufficient charge for reliable operation up to 20 kbps.
3.  $RX_{IN}$  must never be allowed to reach a negative voltage with respect to  $V_{DRV-}$  or excessive currents will be drawn. Therefore, if negative voltage swings are present on  $RX_{IN}$ ,  $V_{DRV-}$  should not be connected to ground and the circuit shown in Figure 4 should be used.

**ABSOLUTE MAXIMUM RATINGS\***

$V_{CC}$	-0.3V to +7.0V
$V_{DR+}$	-0.3V to +13V
$V_{DR-}$	-13V to +0.3V
$RX_{IN}$	-15V to +15V
$TX_{IN}$	-0.3V to $V_{CC}+0.3V$
$TX_{OUT}$	-15V to +15V
$RX_{OUT}$	-0.3V to $V_{CC}+0.3V$
Operating Temperature	0°C to 70°C
Storage Temperature	-55°C to +125°C
Soldering Temperature	260°C for 10 seconds

\* This is a stress rating only and functional operation of the device at these or any other conditions above those indicated in the operation sections of this specification is not implied. Exposure to absolute maximum rating conditions for extended periods of time may affect reliability.

**RECOMMENDED DC OPERATING CONDITIONS** $(t_A = 0^\circ\text{C to } 70^\circ\text{C})$ 

PARAMETER	SYMBOL	CONDITION	MIN	TYP	MAX	UNITS	NOTES
Logic Supply Voltage	$V_{CC}$		2.7	3-5	5.5	V	1
Transmit Driver Supply	$V_{DR+}$	$V_{CC}=5V\pm 10\%$	$V_{CC}$	5-12	13	V	1
	$V_{DR+}$	$V_{CC} 2.7-3.6V$	$V_{CC}$	3-5	5.5	V	1
Transmit Driver Supply	$V_{DR-}$		-15		0	V	1
High-level Input Voltage	$V_{IH}$		2		$V_{CC}+0.3$	V	
Low-level Input Voltage	$V_{IL}$		-0.3		0.8	V	
$RX_{IN}$ Input Voltage	$V_{RS}$		-15		+15	V	1

**ELECTRICAL CHARACTERISTICS-3V OPERATION** $(t_A = 0^\circ\text{C to } 70^\circ\text{C})$ 

PARAMETER	SYMBOL	CONDITION	MIN	TYP	MAX	UNITS	NOTES
Logic Supply Voltage	$V_{CC}$		2.7		3.6	V	
Dynamic Supply Current	$I_{DRV1}$	$TX_{IN} = V_{CC}$		400	800	$\mu\text{A}$	2
	$I_{CC1}$	$TX_{IN} = V_{CC}$		40	100	$\mu\text{A}$	2
	$I_{DRV1}$	$TX_{IN} = \text{GND}$		3.8	5	mA	2
	$I_{CC1}$	$TX_{IN} = \text{GND}$		40	100	$\mu\text{A}$	2
Static Supply Current	$I_{DRV2}$	$TX_{IN} = V_{CC}$		1.5	10	$\mu\text{A}$	3
	$I_{CC2}$	$TX_{IN} = V_{CC}$		10	15	$\mu\text{A}$	3
	$I_{DRV2}$	$TX_{IN} = \text{GND}$		3.8	5	mA	3
	$I_{CC2}$	$TX_{IN} = \text{GND}$		10	20	$\mu\text{A}$	3
Driver Leakage Current	$I_{DRV3}$	$V_{CC} = 0$		0.05	1	$\mu\text{A}$	4
$TX_{OUT}$ Level High	$V_{OTXH}$	$V_{DRV+}=V_{CC}=2.7V$ $V_{DRV-}=0$	2	2.4		V	5
		$V_{DRV+}=4.5V$ , $V_{DRV-}=-12V$	3.8	4		V	6

**ELECTRICAL CHARACTERISTICS-3V OPERATION** cont'd ( $T_A = 0^\circ\text{C}$  to  $70^\circ\text{C}$ )

PARAMETER	SYMBOL		MIN	TYP	MAX	UNITS	NOTES
TX <sub>OUT</sub> Level Low	V <sub>OTXL</sub>	V <sub>DRV+</sub> = V <sub>CC</sub> = 2.7V V <sub>DRV-</sub> = 0		0.2	0.3	V	5
				-11	-10	V	6
TX <sub>OUT</sub> Short Circuit Current	I <sub>SC</sub>	V <sub>DRV+</sub> = 5.5V, V <sub>DRV-</sub> = -12V			85	mA	7
TX <sub>OUT</sub> Output Slew Rate	t <sub>SR</sub>				30	V/us	
Propagation Delay	t <sub>PD</sub>			5		us	8
RX <sub>IN</sub> Input Threshold Low	V <sub>TL</sub>		0.8	1.0	1.6	V	
RX <sub>IN</sub> Input Threshold High	V <sub>TH</sub>		1.2	2.0	2.4	V	
RX <sub>IN</sub> Threshold Hysteresis	V <sub>HYS</sub>		0.4	1.0		V	9
RX <sub>OUT</sub> Output Current High	I <sub>OH</sub>	V <sub>CC</sub> = 2.7V V <sub>OH</sub> = 2V			-0.5	mA	
RX <sub>OUT</sub> Output Current Low	I <sub>OL</sub>	V <sub>CC</sub> = 2.7V V <sub>OL</sub> = 0.4V	0.5			mA	

**NOTES:**

1. V<sub>DRV+</sub> must be greater than or equal to V<sub>CC</sub>, RX<sub>IN</sub> must be greater than V<sub>DRV-</sub>.
2. See test circuit in Figure 5.
3. See test circuit in Figure 6.
4. See test circuit in Figure 7.
5. R<sub>L</sub> = 3kΩ to ground. Max data rate = 20k bps.
6. R<sub>L</sub> = 3kΩ to ground. Max data rate = 50k bps.
7. TX<sub>IN</sub> = V<sub>IL</sub>.
8. See test circuit in Figure 8.
9. V<sub>HYS</sub> = V<sub>TH</sub> - V<sub>TL</sub>.

**+ELECTRICAL CHARACTERISTICS-5V OPERATION** $(t_A = 0^\circ\text{C to } 70^\circ\text{C})$ 

PARAMETER	SYMBOL		MIN	TYP	MAX	UNITS	NOTES
Logic Supply Voltage	$V_{CC}$		4.5	5	5.5	V	
Dynamic Supply Current	$I_{DRV1}$	$TX_{IN} = V_{CC}$		400	800	$\mu\text{A}$	1
	$I_{CC1}$	$TX_{IN} = V_{CC}$		40	100	$\mu\text{A}$	1
	$I_{DRV1}$	$TX_{IN} = \text{GND}$		3.8	5	$\text{mA}$	1
	$I_{CC1}$	$TX_{IN} = \text{GND}$		40	100	$\mu\text{A}$	1
Static Supply Current	$I_{DRV2}$	$TX_{IN} = V_{CC}$		1.5	10	$\mu\text{A}$	2
	$I_{CC2}$	$TX_{IN} = V_{CC}$		10	15	$\mu\text{A}$	2
	$I_{DRV2}$	$TX_{IN} = \text{GND}$		3.8	5	$\text{mA}$	2
	$I_{CC2}$	$TX_{IN} = \text{GND}$		10	20	$\mu\text{A}$	2
Driver Leakage Current	$I_{DRV3}$	$V_{CC} = 0$		0.05	1	$\mu\text{A}$	3
$TX_{OUT}$ Level High	$V_{OTXH}$	$V_{DRV+} = V_{CC} = 4.5\text{V}$ $V_{DRV-} = 0$	3.3	3.8		V	4
		$V_{DRV+} = 12\text{V}$ , $V_{DRV-} = -12\text{V}$	10	11		V	5
$TX_{OUT}$ Level Low	$V_{OTXL}$	$V_{DRV+} = V_{CC} = 12\text{V}$ $V_{DRV-} = -12\text{V}$		-11	-10	V	4
		$V_{DRV+} = V_{CC}$ $V_{DRV-} = 0$		0.2	0.3	V	5
$TX_{OUT}$ Short Circuit Current	$I_{SC}$	$V_{DRV+} = 12\text{V}$ , $V_{DRV-} = -12\text{V}$			85	$\text{mA}$	6
$TX_{OUT}$ Output Slew Rate	$t_{SR}$				30	$\text{V}/\mu\text{s}$	
Propagation Delay	$t_{PD}$			5		$\mu\text{s}$	7
$RX_{IN}$ Input Threshold Low	$V_{TL}$		0.8	1.2	6	V	
$RX_{IN}$ Input Threshold High	$V_{TH}$		1.6	2	2	V	
$RX_{IN}$ Threshold Hysteresis	$V_{HYS}$		0.5	0.8		V	8
$RX_{OUT}$ Output Current High	$I_{OH}$	$V_{CC} = 4.5\text{V}$ $V_{OH} = 2.4\text{V}$			-1	$\text{mA}$	
$RX_{OUT}$ Output Current Low	$I_{OL}$	$V_{CC} = 4.5\text{V}$ $V_{OL} = 0.4\text{V}$	3			$\text{mA}$	

**NOTES:**

1. See test circuit in Figure 9.
2. See test circuit in Figure 10.
3. See test circuit in Figure 11.
4.  $R_L = 3\text{ k}\Omega$  to ground. Max data rate = 20 kbps.
5.  $R_L = 3\text{ k}\Omega$  to ground. Max data rate = 100 kbps.

6.  $TX_{IN} = V_{IL}$ .
7. See test circuit in Figure 12.
8.  $V_{HYS} = V_{TH} - V_{TL}$ .

**DYNAMIC OPERATING CURRENT TEST CIRCUIT Figure 5**

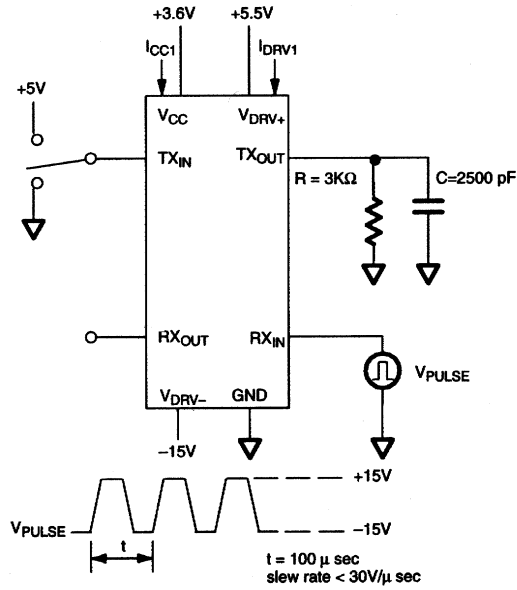

**STATIC OPERATING CURRENT TEST CIRCUIT Figure 6**

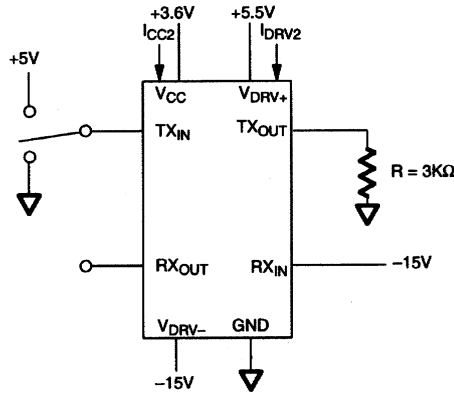

**DRIVER LEAKAGE TEST CIRCUIT Figure 7**

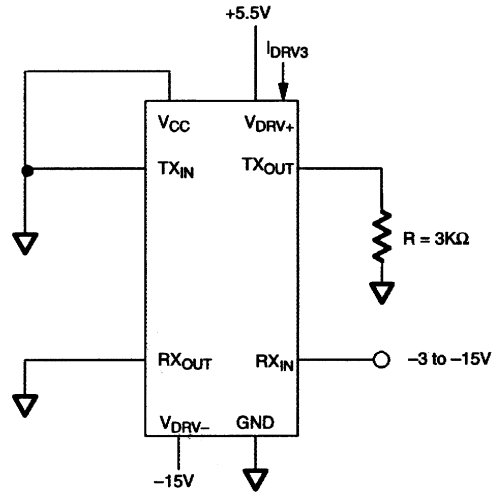

**PROPAGATION DELAY TEST CIRCUIT Figure 8**

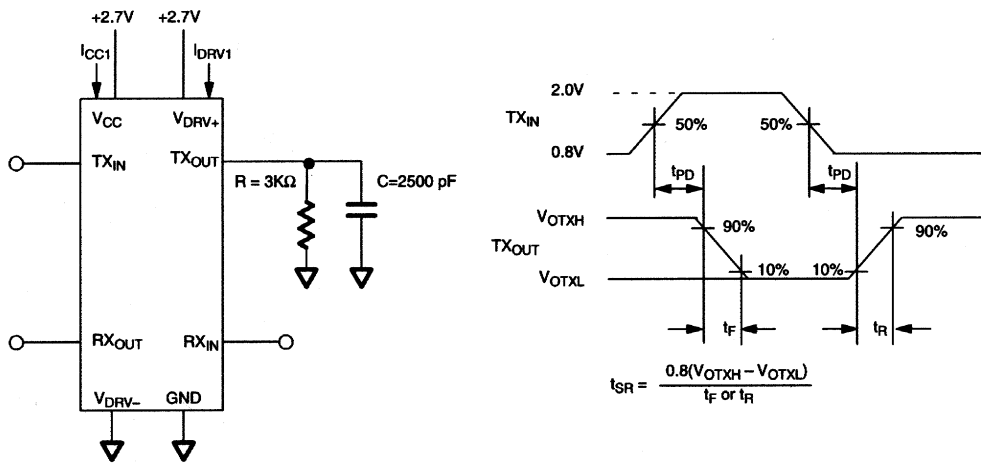

**DYNAMIC OPERATING CURRENT TEST CIRCUIT Figure 9**

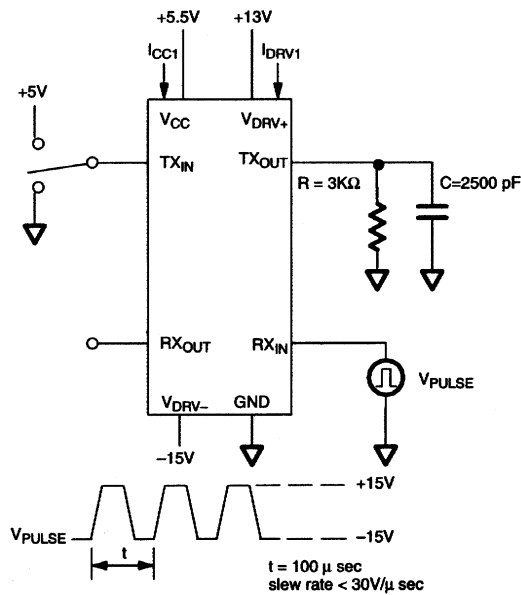

**STATIC OPERATING CURRENT TEST CIRCUIT Figure 10**

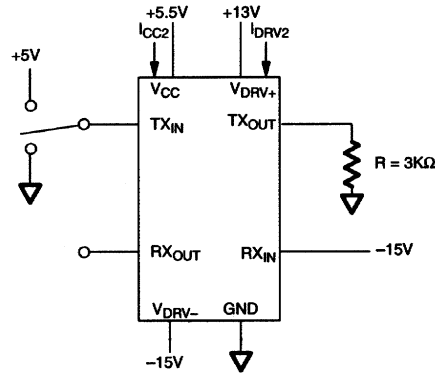

**DRIVER LEAKAGE TEST CIRCUIT Figure 11**

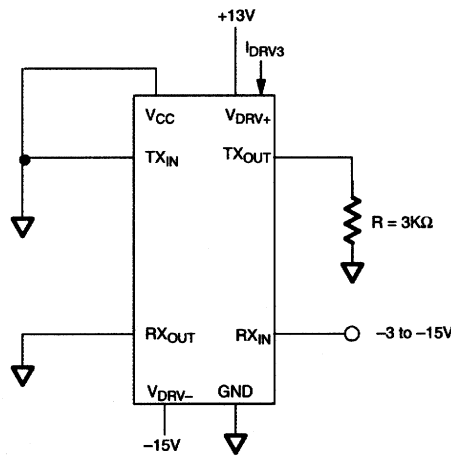

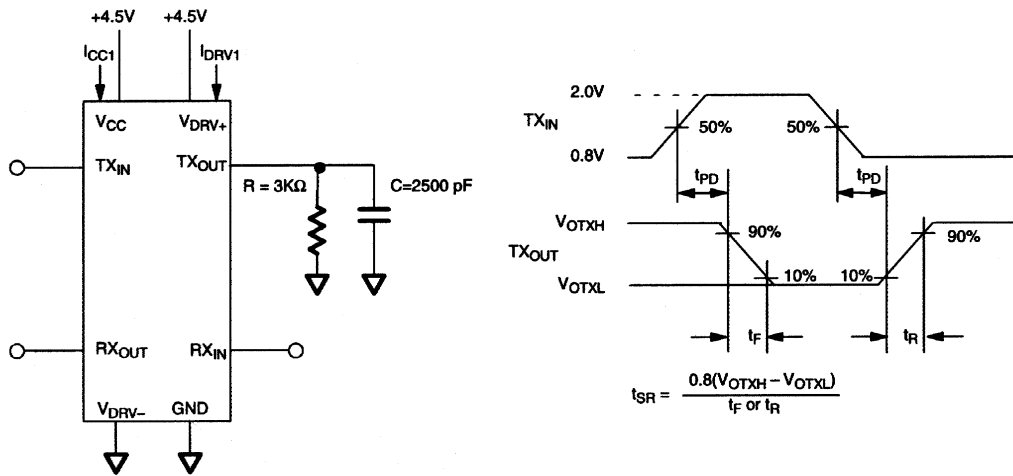

**PROPAGATION DELAY TEST CIRCUIT Figure 12**



## Looking for pricing, stock, or lifecycle information?

Click below to explore more details on WIN SOURCE:

-  [View DS276S+](#) on WIN SOURCE
-  [Maxim Integrated](#) Information

## Optimize Your Supply Chain with WIN SOURCE Solutions

-  Global Sourcing Solution
-  Obsolete Management
-  Cost Control Management
-  Shortage Management
-  Alternative Solution
-  Excess Inventory Management