



**THE DATASHEET OF  
PVZ3G153C01R00**



# Trimmer Potentiometers



## SMD Open Type 3mm Size PVZ3/PVS3/PVA3 Series

### PVZ3 Series

#### ■ Features

1. Excellent solderability characteristics are achieved via special plating techniques on each termination.
2. Specially designed substrate prevents wicking of flux onto the top of the part body.
3. Enlarged bottom termination enhance soldering strength while reducing the necessary land area required promoting high-density PCB mounting.
4. Funnel shaped adjustment slot allows for in-process automatic adjustment.
5. Flat surface is provided for smooth pick and place. (PVZ3K only)
6. Heat-Resistant type is available. (PVZ3AxxxB01)
7. The standard position of driver plate is adjusted at the center normally, but another position is also available.
8. This product meets Pb-free.

#### ■ Applications

- |                      |                        |
|----------------------|------------------------|
| 1. Optical pick up   | 2. Cordless telephones |
| 3. CD players        | 4. FDD                 |
| 5. Motor             | 6. CD-ROMs             |
| 7. Car stereos       | 8. TFT-LCD TV sets     |
| 9. Headphone stereos |                        |



PVZ3A

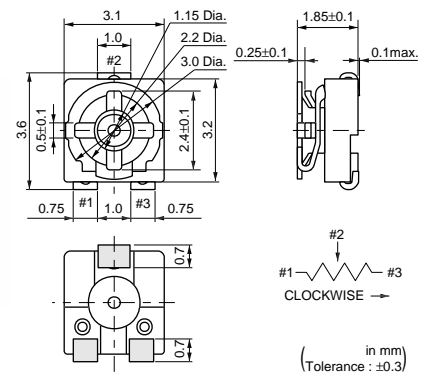

PVZ3K

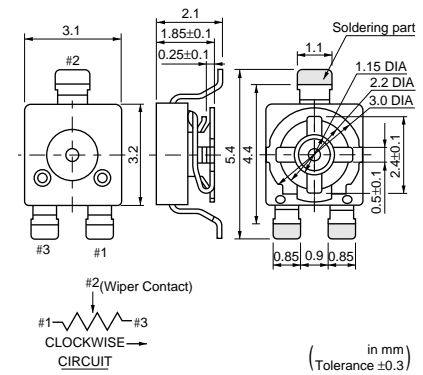

PVZ3R

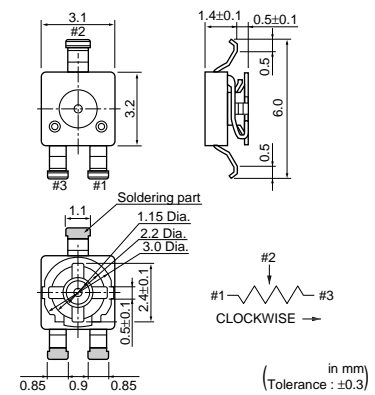

PVZ3T

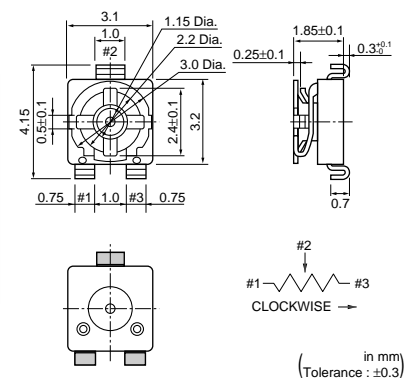

Part Number	Power Rating (W)	Soldering Method	Number of Turns (Effective Rotation Angle)	Total Resistance Value	TCR (ppm/°C)
PVZ3□201A01	0.1(50°C)	Reflow	1(230°±10°)	200ohm ±30%	±500
PVZ3□301A01	0.1(50°C)	Reflow	1(230°±10°)	300ohm ±30%	±500
PVZ3□501A01	0.1(50°C)	Reflow	1(230°±10°)	500ohm ±30%	±500
PVZ3□102A01	0.1(50°C)	Reflow	1(230°±10°)	1k ohm ±30%	±500
PVZ3□202A01	0.1(50°C)	Reflow	1(230°±10°)	2k ohm ±30%	±500
PVZ3□302A01	0.1(50°C)	Reflow	1(230°±10°)	3k ohm ±30%	±500
PVZ3□502A01	0.1(50°C)	Reflow	1(230°±10°)	5k ohm ±30%	±500
PVZ3□103A01	0.1(50°C)	Reflow	1(230°±10°)	10k ohm ±30%	±500
PVZ3□203A01	0.1(50°C)	Reflow	1(230°±10°)	20k ohm ±30%	±500
PVZ3□303A01	0.1(50°C)	Reflow	1(230°±10°)	30k ohm ±30%	±500
PVZ3□503A01	0.1(50°C)	Reflow	1(230°±10°)	50k ohm ±30%	±500
PVZ3□104A01	0.1(50°C)	Reflow	1(230°±10°)	100k ohm ±30%	±500
PVZ3□204A01	0.1(50°C)	Reflow	1(230°±10°)	200k ohm ±30%	±500
PVZ3□304A01	0.1(50°C)	Reflow	1(230°±10°)	300k ohm ±30%	±500
PVZ3□504A01	0.1(50°C)	Reflow	1(230°±10°)	500k ohm ±30%	±500
PVZ3□105A01	0.1(50°C)	Reflow	1(230°±10°)	1M ohm ±30%	±500
PVZ3□205A01	0.1(50°C)	Reflow	1(230°±10°)	2M ohm ±30%	±500
PVZ3□201C01	0.1(50°C)	Reflow	1(230°±10°)	200ohm ±30%	±500
PVZ3□301C01	0.1(50°C)	Reflow	1(230°±10°)	300ohm ±30%	±500
PVZ3□501C01	0.1(50°C)	Reflow	1(230°±10°)	500ohm ±30%	±500
PVZ3□102C01	0.1(50°C)	Reflow	1(230°±10°)	1k ohm ±30%	±500
PVZ3□202C01	0.1(50°C)	Reflow	1(230°±10°)	2k ohm ±30%	±500
PVZ3□302C01	0.1(50°C)	Reflow	1(230°±10°)	3k ohm ±30%	±500
PVZ3□502C01	0.1(50°C)	Reflow	1(230°±10°)	5k ohm ±30%	±500
PVZ3□103C01	0.1(50°C)	Reflow	1(230°±10°)	10k ohm ±30%	±500
PVZ3□203C01	0.1(50°C)	Reflow	1(230°±10°)	20k ohm ±30%	±500
PVZ3□303C01	0.1(50°C)	Reflow	1(230°±10°)	30k ohm ±30%	±500
PVZ3□503C01	0.1(50°C)	Reflow	1(230°±10°)	50k ohm ±30%	±500
PVZ3□104C01	0.1(50°C)	Reflow	1(230°±10°)	100k ohm ±30%	±500
PVZ3□204C01	0.1(50°C)	Reflow	1(230°±10°)	200k ohm ±30%	±500
PVZ3□304C01	0.1(50°C)	Reflow	1(230°±10°)	300k ohm ±30%	±500
PVZ3□504C01	0.1(50°C)	Reflow	1(230°±10°)	500k ohm ±30%	±500
PVZ3□105C01	0.1(50°C)	Reflow	1(230°±10°)	1M ohm ±30%	±500
PVZ3□205C01	0.1(50°C)	Reflow	1(230°±10°)	2M ohm ±30%	±500

The blank column is filled with the code of adjustment direction A/T (top) or K/R (rear).  
The last three digits express the individual specification codes. A01 for standard type and B01 for high-resistant type.

■ Construction

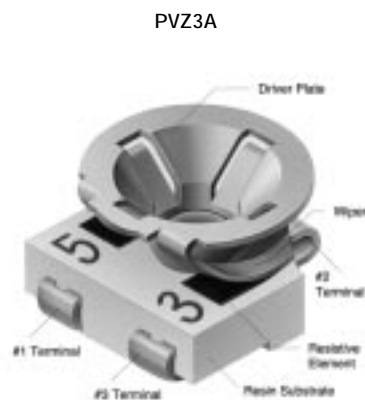

■ Standard Land Pattern

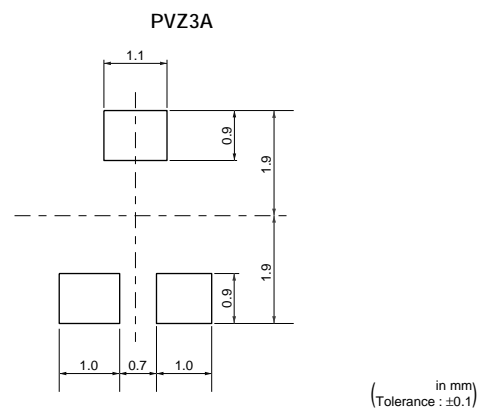

Continued on the following page.

⚠Note Please read rating and ⚠CAUTION (for storage and operating, rating, soldering and mounting, handling) in this PDF catalog to prevent smoking and/or burning, etc.  
This catalog has only typical specifications. Therefore, you are requested to approve our product specification or to transact the approval sheet for product specification before ordering.

Continued from the preceding page.

■ Construction

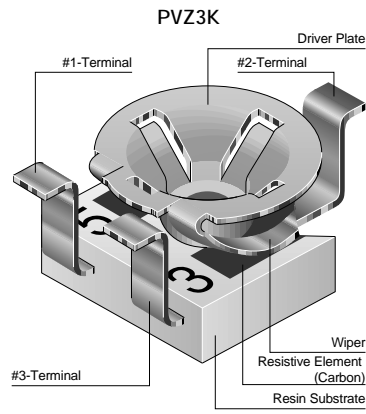

■ Standard Land Pattern

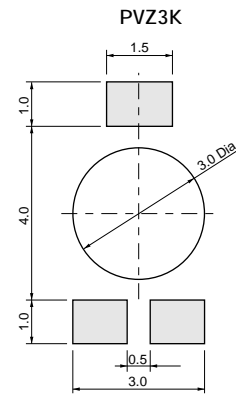

(in mm)  
(Tolerance : ±0.1)

2

■ Construction

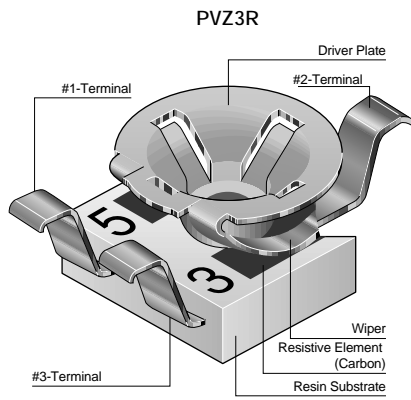

■ Standard Land Pattern

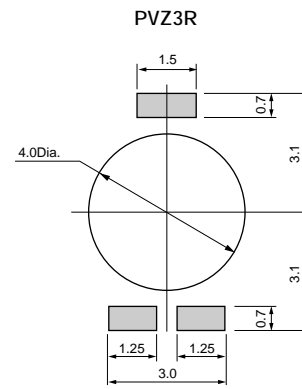

(in mm)

■ Construction

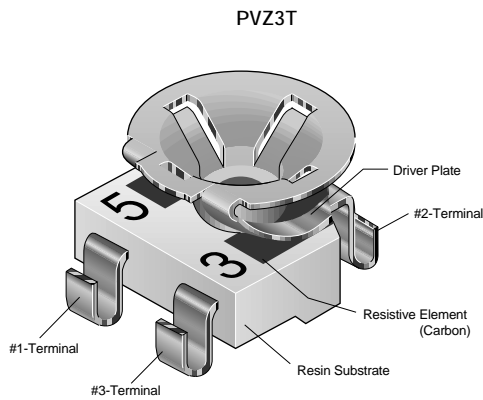

■ Standard Land Pattern

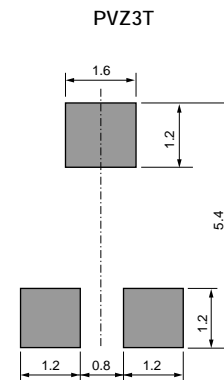

(in mm)  
(Tolerance : ±0.3)

■ Characteristics

Humidity Exposure	Res. Change : +10, -2%
High Temperature Exposure	Res. Change : $R \leq 100\text{kohm} \dots +2, -10\%$ $100\text{kohm} < R \dots +2, -15\%$
Humidity Load Life	Res. Change : ±10%
Load Life	Res. Change : $R \leq 100\text{kohm} \dots +2, -10\%$ $100\text{kohm} < R \dots +2, -15\%$
Temperature Cycle	Res. Change : ±5%
Temperature Coefficient of Resistance	±500ppm/°C
Rotational Life	Res. Change : ±10% (10 cycles)

## PVS3 Series

### ■ Features

1. Funnel shaped slot allows for in-process automatic adjustment and it provides superior adjustability.
2. 3mm miniature package lead a high density PCB mounting.
3. Low profile of 1.5mm height with stopper.
4. Plated termination achieve a high resistance to solder leaching.
5. Available for adjusting by screwdrivers on the market.

### ■ Applications

1. Camcorders
2. Video disk players
3. TFT-LCD TV sets
4. Headphone stereos
5. Cordless telephones
6. Micro-motors
7. Optical cameras

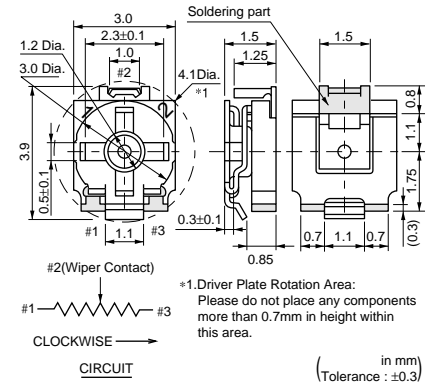

Part Number	Power Rating (W)	Soldering Method	Number of Turns (Effective Rotation Angle)	Total Resistance Value	TCR (ppm/°C)
PVS3A101A01	0.1(70°C)	Reflow	1(270°±10°)	100ohm ±25%	±250
PVS3A201A01	0.1(70°C)	Reflow	1(270°±10°)	200ohm ±25%	±250
PVS3A301A01	0.1(70°C)	Reflow	1(270°±10°)	300ohm ±25%	±250
PVS3A501A01	0.1(70°C)	Reflow	1(270°±10°)	500ohm ±25%	±250
PVS3A102A01	0.1(70°C)	Reflow	1(270°±10°)	1k ohm ±25%	±250
PVS3A202A01	0.1(70°C)	Reflow	1(270°±10°)	2k ohm ±25%	±250
PVS3A302A01	0.1(70°C)	Reflow	1(270°±10°)	3k ohm ±25%	±250
PVS3A502A01	0.1(70°C)	Reflow	1(270°±10°)	5k ohm ±25%	±250
PVS3A103A01	0.1(70°C)	Reflow	1(270°±10°)	10k ohm ±25%	±250
PVS3A203A01	0.1(70°C)	Reflow	1(270°±10°)	20k ohm ±25%	±250
PVS3A303A01	0.1(70°C)	Reflow	1(270°±10°)	30k ohm ±25%	±250
PVS3A503A01	0.1(70°C)	Reflow	1(270°±10°)	50k ohm ±25%	±250
PVS3A104A01	0.1(70°C)	Reflow	1(270°±10°)	100k ohm ±25%	±250
PVS3A204A01	0.1(70°C)	Reflow	1(270°±10°)	200k ohm ±25%	±250
PVS3A304A01	0.1(70°C)	Reflow	1(270°±10°)	300k ohm ±25%	±250
PVS3A504A01	0.1(70°C)	Reflow	1(270°±10°)	500k ohm ±25%	±250
PVS3A105A01	0.1(70°C)	Reflow	1(270°±10°)	1M ohm ±25%	±250
PVS3A205A01	0.1(70°C)	Reflow	1(270°±10°)	2M ohm ±25%	±250

### ■ Construction

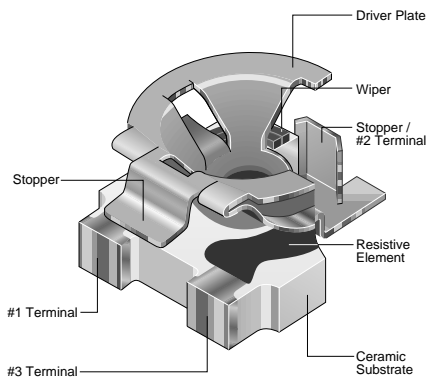

### ■ Standard Land Pattern

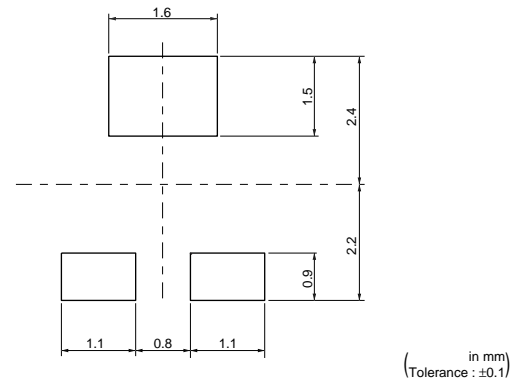

Continued on the following page.

⚠Note Please read rating and ⚠CAUTION (for storage and operating, rating, soldering and mounting, handling) in this PDF catalog to prevent smoking and/or burning, etc.  
This catalog has only typical specifications. Therefore, you are requested to approve our product specification or to transact the approval sheet for product specification before ordering.

↳ Continued from the preceding page.

■ Characteristics

Humidity Exposure	Res. Change : ±3%
High Temperature Exposure	Res. Change : ±3%
Humidity Load Life	Res. Change : ±3%
Load Life	Res. Change : ±3%
Temperature Cycle	Res. Change : ±3%
Temperature Coefficient of Resistance	±250ppm/°C
Rotational Life	Res. Change : ±10% (10 cycles)

2

## PVA3 Series

### ■ Features

1. Funnel shaped slot allows for in-process automatic adjustment and it provides superior adjustability.
2. 3mm miniature package lead a high density PCB mounting.
3. Plated termination achieve a high resistance to solder leaching.
4. Available for adjusting by screwdrivers on the market.
5. Recommended for both reflow and flow soldering method. (Need cleaning for flow soldering method)

### ■ Applications

1. Camcorders
2. Video disk players
3. TFT-LCD TV sets
4. Headphone stereos
5. Cordless telephones
6. Micro-motors
7. Optical cameras

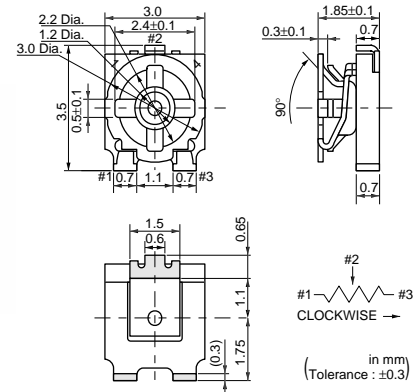

Part Number	Power Rating (W)	Soldering Method	Number of Turns (Effective Rotation Angle)	Total Resistance Value	TCR (ppm/°C)
PVA3A101A01	0.1(70°C)	Flow/Reflow	1(270°±10°)	100ohm ±25%	±250
PVA3A201A01	0.1(70°C)	Flow/Reflow	1(270°±10°)	200ohm ±25%	±250
PVA3A301A01	0.1(70°C)	Flow/Reflow	1(270°±10°)	300ohm ±25%	±250
PVA3A501A01	0.1(70°C)	Flow/Reflow	1(270°±10°)	500ohm ±25%	±250
PVA3A102A01	0.1(70°C)	Flow/Reflow	1(270°±10°)	1k ohm ±25%	±250
PVA3A202A01	0.1(70°C)	Flow/Reflow	1(270°±10°)	2k ohm ±25%	±250
PVA3A302A01	0.1(70°C)	Flow/Reflow	1(270°±10°)	3k ohm ±25%	±250
PVA3A502A01	0.1(70°C)	Flow/Reflow	1(270°±10°)	5k ohm ±25%	±250
PVA3A103A01	0.1(70°C)	Flow/Reflow	1(270°±10°)	10k ohm ±25%	±250
PVA3A203A01	0.1(70°C)	Flow/Reflow	1(270°±10°)	20k ohm ±25%	±250
PVA3A303A01	0.1(70°C)	Flow/Reflow	1(270°±10°)	30k ohm ±25%	±250
PVA3A503A01	0.1(70°C)	Flow/Reflow	1(270°±10°)	50k ohm ±25%	±250
PVA3A104A01	0.1(70°C)	Flow/Reflow	1(270°±10°)	100k ohm ±25%	±250
PVA3A204A01	0.1(70°C)	Flow/Reflow	1(270°±10°)	200k ohm ±25%	±250
PVA3A304A01	0.1(70°C)	Flow/Reflow	1(270°±10°)	300k ohm ±25%	±250
PVA3A504A01	0.1(70°C)	Flow/Reflow	1(270°±10°)	500k ohm ±25%	±250
PVA3A105A01	0.1(70°C)	Flow/Reflow	1(270°±10°)	1M ohm ±25%	±250
PVA3A205A01	0.1(70°C)	Flow/Reflow	1(270°±10°)	2M ohm ±25%	±250

### ■ Construction

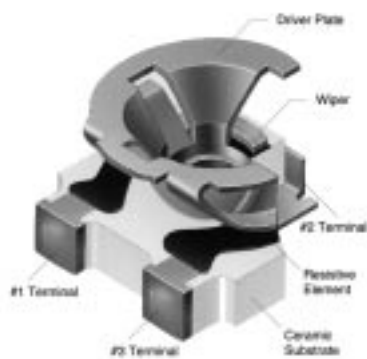

### ■ Standard Land Pattern

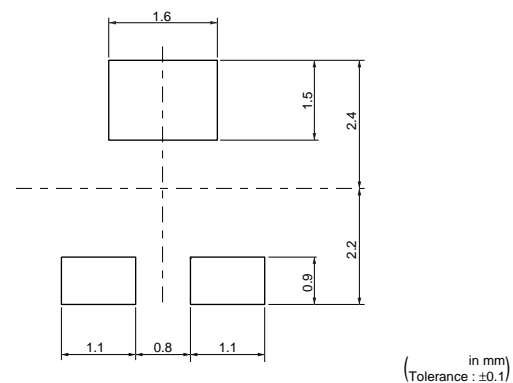

Continued on the following page. ↗

⚠Note Please read rating and ⚠CAUTION (for storage and operating, rating, soldering and mounting, handling) in this PDF catalog to prevent smoking and/or burning, etc.  
This catalog has only typical specifications. Therefore, you are requested to approve our product specification or to transact the approval sheet for product specification before ordering.

↳ Continued from the preceding page.

■ Characteristics

Humidity Exposure	Res. Change : ±3%
High Temperature Exposure	Res. Change : ±3%
Humidity Load Life	Res. Change : ±3%
Load Life	Res. Change : ±3%
Temperature Cycle	Res. Change : ±3%
Temperature Coefficient of Resistance	±250ppm/°C
Rotational Life	Res. Change : ±10% (10 cycles)

2

## PVZ3/PVS3/PVA3 Series Notice

2

### ■ Notice (Operating and Storage Conditions)

1. Store that the temperature is -10 to +40deg. C and the relative humidity is 30-85%RH.
2. Do not store in or near corrosive gases.
3. Use within six months after delivery.
4. Open the package just before using.
5. Do not store under direct sunlight.
6. The trimmer potentiometer should not be used under the following environmental conditions:  
If you use the trimmer potentiometer in an environment other than these listed below, please consult with Murata factory representative prior to

using.

- (1) Corrosive gaseous atmosphere.  
(Ex. Chlorine gas, Hydrogen sulfide gas, Ammonia gas, Sulfuric acid gas, Nitric oxide gas, etc.)
- (2) In liquid.  
(Ex. Oil, Medical liquid, Organic solvent, etc.)
- (3) Dusty/dirty atmosphere.
- (4) Direct sunlight.
- (5) Static voltage nor electric/magnetic fields.
- (6) Direct sea breeze.
- (7) Other variations of the above.

### ■ Notice (Rating)

1. When using with partial load (rheostat), minimize the power depend on the resistance value.
2. The maximum input voltage to a trimmer potentiometer should not exceed  $(P \cdot R)^{1/2}$  or the maximum operating voltage, whichever is smaller.
3. The maximum input current to a trimmer potentiometer should not exceed  $(P/R)^{1/2}$  or the allowable wiper current, whichever is smaller.
4. If the trimmer potentiometer is used in DC and high humidity condition, please connect wiper (#2) for plus and resistive element (#1 or #3) for minus.

### ■ Notice (Soldering and Mounting)

#### 1. Soldering

##### (1) Standard soldering condition

###### (a) Reflow soldering :

Refer to the standard temperature profile.

###### (b) Soldering iron:

\*PVZ3AxxxA01, PVZ3KxxxA01, PVA3, PVS3 series

>Temperature of tip 260deg. C max.

>Soldering time 3sec. max.

>Diameter 1mm max.

>Wattage of iron 30W max.

\*PVZ3AxxxB01, PVZ3KxxxB01 series

>Temperature of tip 310deg. C max.

>Soldering time 5sec. max.

>Diameter 1mm max.

>Wattage of iron 30W max.

Before using other soldering conditions than those listed above, please consult with Murata factory representative prior to using. If the soldering conditions are not suitable, e. g., excessive time and/or excessive temperature, the trimmer potentiometer may deviate from the specified characteristics.

##### (2) Flow soldering is available for PVA3 series.

For PVZ3A, PVZ3K and PVS3, do not use flow soldering method (dipping).

If you use the flow soldering method, the trimmer potentiometer may not function.

(3) The soldering iron should not come in contact with the case of the trimmer potentiometer. If such contact does occur, the trimmer potentiometer may be damaged.

##### (4) Apply the appropriate amount of solder paste.

The thickness of solder paste should be printed from 150micro m to 200micro m (PVZ3K series should be printed from 100micro m to 150micro m) and the dimension of land pattern should be used Murata's standard land pattern at reflow soldering. Insufficient amounts of solder can lead to insufficient soldering strength on PCB. Excessive amounts of solder may cause the bridging between the terminals.

#### 2. Mounting

(1) Use our standard land dimension. Excessive land area causes displacement due to effect of the surface tension of the solder. Insufficient land area leads to insufficient soldering strength of the chip.

(2) Do not apply excessive force (preferable 4.9N (Ref.; 500gf) max.), when the trimmer potentiometer is mounted to the PCB.

(3) Do not warp and/or bend PC board to prevent trimmer potentiometer from breakage.

(4) In chip placers, the recommended size of the cylindrical pick-up nozzle should be outer

Continued on the following page. 

## PVZ3/PVS3/PVA3 Series Notice

Continued from the preceding page.

dimension 2.5-2.8mm dia. and inner dimension 2mm dia.

### 3. Cleaning

- (1) In case there is flux on the resistive element, clean sufficiently by cleaning solvents and

remove all residual flux perfectly.

- (2) Isopropyl-alcohol and Ethyl-alcohol are applicable solvent for cleaning. If you use any other types of solvents, please consult with Murata factory representative prior to using.

2

### ■ Flow Soldering Standard Profile

PVA3 Series Only

For flow soldering

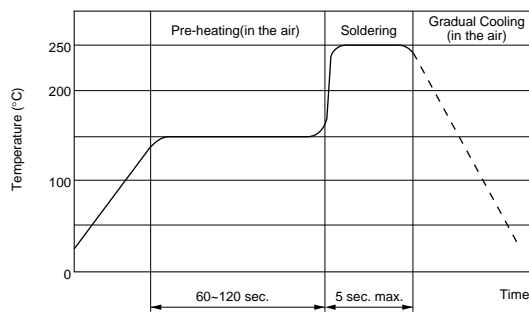

### ■ Reflow Soldering Standard Profile

PVA3/PVS3/PVZ3\_A01 Series

For reflow soldering

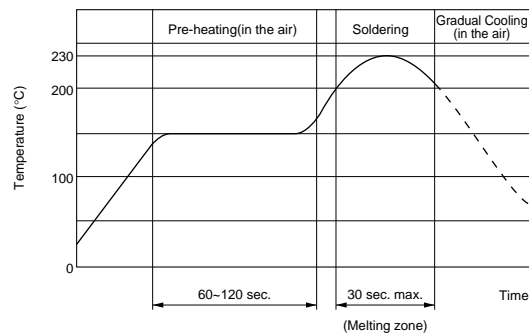

PVZ3\_C01 Series

For reflow soldering

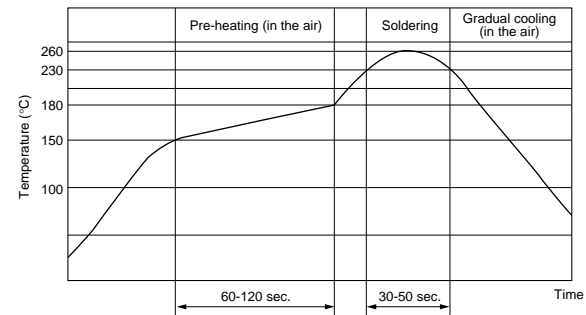

### ■ Notice (Handling)

1. Use suitable screwdrivers that fit comfortably in driver slot. We recommend the below screwdrivers.
  - \* Recommended screwdriver for manual adjustment  
<PVZ3A/PVA3 series>  
VESSEL MFG. : NO.9000+1.7x30  
(Murata P/N : KMDR080)
  - <PVZ3A/PVA3/PVS3 series>  
TORAY MFG. : SA-2225  
(Murata P/N : KMDR070)
  - \* Recommended screwdriver for automatic adjustment  
TORAY MFG. : JB-2225  
(Murata P/N : KMBT070)
2. Don't apply more than 4.9N (Ref.; 500gf) of twist

and stress after mounted onto PCB to prevent contact intermittence. If excessive force is applied, the trimmer potentiometer may not function.

3. For PVZ3 and PVA3series, please use within the effective rotational angle.  
The potentiometer dose not have a mechanical stop for over rotation. In case out of effective rotational angle, the trimmer potentiometer may not function.
4. When using a lock paint to fix slot position, please consult with Murata factory representative prior to using to prevent corrosion and contact intermittence.

## PVZ3/PVS3/PVA3 Series Notice

### ■ Notice (Other)

1. Please make sure that your product has been evaluated and confirmed against your specifications when our product is mounted to your product.
2. Murata cannot guarantee trimmer potentiometer integrity when used under conditions other than those specified in this document.

2

## SMD Open Type and PVM4A\_A01 Series Specifications and Test Methods

The tests and measurements shall be conducted under the condition of 15 to 35°C of temperature, 25 to 75% of relative humidity and 86 to 106 kpa of atmospheric pressure unless otherwise specified. In case when entertained a doubt in judgment obtained from results measured in accordance with the above mentioned conditions, the tests and measurements shall be conducted under the condition of 25±2°C of temperature and, 45 to 55% of relative humidity and 86 to 106 kpa of atmospheric pressure.

No.	Item	Test Methods																														
1	Total Resistance	<p>Measure total resistance between the resistance element and terminals (terminals #1 and #3) with the contact arm positioned against a stop. The positioning of the contact arm and terminal shall be the same for subsequent total resistance measurements on the same device.</p> <p>Use the test voltage specified in Table-1 for total resistance measurements. This voltage shall be used whenever a subsequent total resistance measurement is made.</p> <table border="1"> <thead> <tr> <th>Total resistance, Nominal (ohm)</th> <th>Maximum Test Voltage (V)</th> </tr> </thead> <tbody> <tr> <td>10≤R≤100</td> <td>1.0</td> </tr> <tr> <td>100&lt;R≤1k</td> <td>3.0</td> </tr> <tr> <td>1k&lt;R≤10k</td> <td>10.0</td> </tr> <tr> <td>10k&lt;R≤100k</td> <td>30.0</td> </tr> <tr> <td>100k&lt;R</td> <td>100.0</td> </tr> </tbody> </table> <p>Table-1 Total resistance test voltage</p>	Total resistance, Nominal (ohm)	Maximum Test Voltage (V)	10≤R≤100	1.0	100<R≤1k	3.0	1k<R≤10k	10.0	10k<R≤100k	30.0	100k<R	100.0																		
Total resistance, Nominal (ohm)	Maximum Test Voltage (V)																															
10≤R≤100	1.0																															
100<R≤1k	3.0																															
1k<R≤10k	10.0																															
10k<R≤100k	30.0																															
100k<R	100.0																															
2	Residual Resistant	<p>Position the contact arm at the extreme counterclockwise limit of mechanical travel and measure the resistance between the contact arm and the corresponding end terminal. Then, position the contact arm at the extreme clockwise limit of mechanical travel and measure the resistance between the contact arm and the corresponding end terminal. During this test, take suitable precautions to ensure that the rated current of the resistance element is not exceeded.</p>																														
3	Contact Resistance	<p>Contact resistance variation shall be measured with the measuring circuit shown in below, or its equivalent. The operating wiper shall be rotated in both directions through 90% of the actual effective-electrical travel for a total of 6 cycles.</p> <p>The rate of rotation of the operating wiper shall be such that the wiper completes 1 countin determining whether or not a contact resistance variation is observed at least twice in the same location. The test current shall follow the value given in Table-2 unless otherwise limited by the power rating.</p> <table border="1"> <thead> <tr> <th>Standard total resistance R (ohm)</th> <th>Test Current</th> </tr> </thead> <tbody> <tr> <td>100≤R&lt;10k</td> <td>10mA Max.</td> </tr> <tr> <td>10k≤R&lt;100k</td> <td>1mA Max.</td> </tr> <tr> <td>100≤R</td> <td>100μA Max.</td> </tr> </tbody> </table> <p>Table-2 Test current for CRV</p> <p>Figure-1 CRV measuring circuit</p>	Standard total resistance R (ohm)	Test Current	100≤R<10k	10mA Max.	10k≤R<100k	1mA Max.	100≤R	100μA Max.																						
Standard total resistance R (ohm)	Test Current																															
100≤R<10k	10mA Max.																															
10k≤R<100k	1mA Max.																															
100≤R	100μA Max.																															
4	Humidity Exposure	<p>The wiper contact point shall be pre-setted at about 50% position of effective rotational angle. After that, the potentiometer shall be placed in a chamber at 40±2°C and 90 - 95% without loading for 500±12 hours. The resistance value shall be measured after keeping the potentiometer in a room for 5±1/6 hours.</p>																														
5	High Temperature Exposure	<p>The wiper contact point shall be pre-setted at about 50% position of effective rotational angle. After that, the potentiometer shall be placed in a chamber at 70±2°C without loading for 500±12 hours. The resistance value shall be measured after keeping the potentiometer in a room for 1.5±1/6 hours.</p>																														
6	Humidity Load Life	<p>The wiper contact point shall be pre-setted at about 50% position of effective rotational angle. After that, the potentiometer shall be placed in a chamber at 40±2°C and 90 - 95% with loading the 1/2 rated voltage between #1 and #2 terminals, intermittently 1.5 hours ON and 0.5 hours OFF for 1000±12hours. The resistance value shall be measured after keeping the potentiometer in a room for 5±1/6 hours.</p>																														
7	Load Life	<p>The wiper contact point shall be pre-setted at about 50% position of effective rotational angle. After that, the potentiometer shall be placed in a chamber at 70±2°C (50±2°C for PVZ) with loading the 1/2 rated voltage between #1 and #2 terminals, intermittently 1.5 hours ON and 0.5 hours OFF for 1000±12 hours. The resistance value shall be measured after keeping the potentiometer in a room for 1.5±1/6 hours.</p>																														
8	Temperature Cycle	<p>The wiper contact point shall be pre-setted at about 50% position of effective rotational angle. After that, the potentiometer shall be subjected to Table-3, Table-4 temperature for 5 cycles. The resistance value shall be measured after keeping the potentiometer in a room for 1.5±10 minutes.</p> <table border="1"> <thead> <tr> <th>Sequence</th> <th>1</th> <th>2</th> <th>3</th> <th>4</th> </tr> </thead> <tbody> <tr> <td>Temp. (°C)</td> <td>-25±3</td> <td>+25±2</td> <td>+85±3</td> <td>+25±2</td> </tr> <tr> <td>Time (min.)</td> <td>30±3</td> <td>10Max.</td> <td>30±3</td> <td>10Max.</td> </tr> </tbody> </table> <p>Table-3 PVZ</p> <table border="1"> <thead> <tr> <th>Sequence</th> <th>1</th> <th>2</th> <th>3</th> <th>4</th> </tr> </thead> <tbody> <tr> <td>Temp. (°C)</td> <td>-55±3</td> <td>+25±2</td> <td>+125±3</td> <td>+25±2</td> </tr> <tr> <td>Time (min.)</td> <td>30±3</td> <td>10Max.</td> <td>30±3</td> <td>10Max.</td> </tr> </tbody> </table> <p>Table-4 PVA3/PVS3/PVM4A□□□A01</p>	Sequence	1	2	3	4	Temp. (°C)	-25±3	+25±2	+85±3	+25±2	Time (min.)	30±3	10Max.	30±3	10Max.	Sequence	1	2	3	4	Temp. (°C)	-55±3	+25±2	+125±3	+25±2	Time (min.)	30±3	10Max.	30±3	10Max.
Sequence	1	2	3	4																												
Temp. (°C)	-25±3	+25±2	+85±3	+25±2																												
Time (min.)	30±3	10Max.	30±3	10Max.																												
Sequence	1	2	3	4																												
Temp. (°C)	-55±3	+25±2	+125±3	+25±2																												
Time (min.)	30±3	10Max.	30±3	10Max.																												

Continued on the following page.

## SMD Open Type and PVM4A\_A01 Series Specifications and Test Methods

☒ Continued from the preceding page.

No.	Item	Test Methods																				
9	Temperature Coefficient of Resistance	<p>The trimmer potentiometer shall be subjected to the following each temperature (see Table-5, Table-6) for 30 to 45 minutes. The resistance value shall be measured in the chamber.</p> $TCR = \frac{R_2 - R_1}{R_1 (T_2 - T_1)} \times 10^6 \text{ (ppm/}^\circ\text{C)}$ <p>                     T<sub>1</sub> : Reference temperature in degrees celsius                      T<sub>2</sub> : Test temperature in degrees celsius                      R<sub>1</sub> : Resistance at reference temperature in ohm                      R<sub>2</sub> : Resistance at test temperature in ohm                 </p> <table border="1" style="width: 100%; border-collapse: collapse; margin-bottom: 5px;"> <thead> <tr style="background-color: #eee;"> <th style="width: 15%;">Sequence</th> <th style="width: 15%;">1*</th> <th style="width: 15%;">2</th> <th style="width: 15%;">3*</th> <th style="width: 15%;">4</th> </tr> </thead> <tbody> <tr> <td>Temp. (°C)</td> <td style="text-align: center;">+25±2</td> <td style="text-align: center;">-25±3</td> <td style="text-align: center;">+25±2</td> <td style="text-align: center;">+85±3</td> </tr> </tbody> </table> <p style="text-align: center;">Note)*: Norm Temp. <span style="float: right;">Table-5 PVZ</span></p> <table border="1" style="width: 100%; border-collapse: collapse; margin-bottom: 5px;"> <thead> <tr style="background-color: #eee;"> <th style="width: 15%;">Sequence</th> <th style="width: 15%;">1</th> <th style="width: 15%;">2</th> <th style="width: 15%;">3*</th> <th style="width: 15%;">4</th> </tr> </thead> <tbody> <tr> <td>Temp. (°C)</td> <td style="text-align: center;">+25±2</td> <td style="text-align: center;">-55±3</td> <td style="text-align: center;">+25±2</td> <td style="text-align: center;">+125±3</td> </tr> </tbody> </table> <p style="text-align: center;">Table-6 PVA3/PVS3/PVM4A□□□A01</p>	Sequence	1*	2	3*	4	Temp. (°C)	+25±2	-25±3	+25±2	+85±3	Sequence	1	2	3*	4	Temp. (°C)	+25±2	-55±3	+25±2	+125±3
Sequence	1*	2	3*	4																		
Temp. (°C)	+25±2	-25±3	+25±2	+85±3																		
Sequence	1	2	3*	4																		
Temp. (°C)	+25±2	-55±3	+25±2	+125±3																		
10	Rotational Life	<p>The wiper shall be rotated over 90% of the effective rotational angle without loading at a speed of 10 cycles per minute, for 10 cycles continuously. The resistance value shall be measured after keeping the potentiometer in a room for 10±5 minutes.</p>																				

## Looking for pricing, stock, or lifecycle information?

Click below to explore more details on WIN SOURCE:

[View PVZ3G153C01R00 on WIN SOURCE](#)

[Bourns Inc. Information](#)

## Optimize Your Supply Chain with WIN SOURCE Solutions

- ✓ Global Sourcing Solution
- ✓ Obsolete Management
- ✓ Cost Control Management
- ✓ Shortage Management
- ✓ Alternative Solution
- ✓ Excess Inventory Management