



**THE DATASHEET OF
NB3N51032DTR2G**



Dual HCSL/LVDS Clock Generator, 3.3 V, Crystal to 25 MHz, 100 MHz, 125 MHz and 200 MHz

NB3N51032

The NB3N51032 is a precision, low phase noise clock generator that supports PCI Express and Ethernet requirements. The device accepts a 25 MHz fundamental mode parallel resonant crystal and generates a differential HCSL output at 25 MHz, 100 MHz, 125 MHz or 200 MHz clock frequencies. Outputs can interface with LVDS with proper termination (See Figure 10). The NB3N51032 provides selectable spread options of -0.5% and -0.75% for applications demanding low Electromagnetic Interference (EMI) as well as optimum performance with no spread option.

Features

- Uses 25 MHz Fundamental Mode Parallel Resonant Crystal
- External Loop Filter is Not Required
- HCSL Differential Output or LVDS with Proper Termination
- Four Selectable Multipliers of the Input Frequency
- Output Enable with Tri-State Outputs
- PCIe Gen 1, Gen 2, Gen 3, Gen 4 Compliant
- Spread of -0.5% , -0.75% and No Spread
- Phase Noise: @ 100 MHz

Offset	Noise Power
100 Hz	-88 dBc/Hz
1 kHz	-118 dBc/Hz
10 kHz	-131 dBc/Hz
100 kHz	-132 dBc/Hz
1 MHz	-144 dBc/Hz
10 MHz	-155 dBc/Hz
- Typical Period Jitter RMS of 1.5 ps
- Operating Supply Voltage Range 3.3 V $\pm 5\%$
- Industrial Temperature Range -40°C to $+85^{\circ}\text{C}$
- Functionally Compatible with IDT557-03, IDT5V41065, IDT5V41235 with enhanced performance
- These are Pb-Free Devices

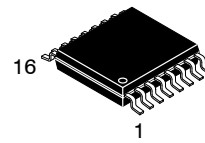

TSSOP-16
 DT SUFFIX
 CASE 948F

- A = Assembly Location
- L = Wafer Lot
- Y = Year
- W = Work Week
- = Pb-Free Package

(Note: Microdot may be in either location)

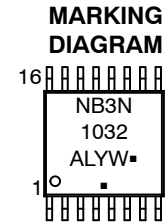

ORDERING INFORMATION

See detailed ordering and shipping information on page 11 of this data sheet.

Applications

- Networking
- Consumer
- Computing and Peripherals
- Industrial Equipment
- PCIe Clock Generation Gen 1, Gen 2, Gen 3 and Gen 4
- Gigabit Ethernet
- FB DIMM

End Products

- Switch and Router
- Set Top Box, LCD TV
- Servers, Desktop Computers
- Automated Test Equipment

NB3N51032

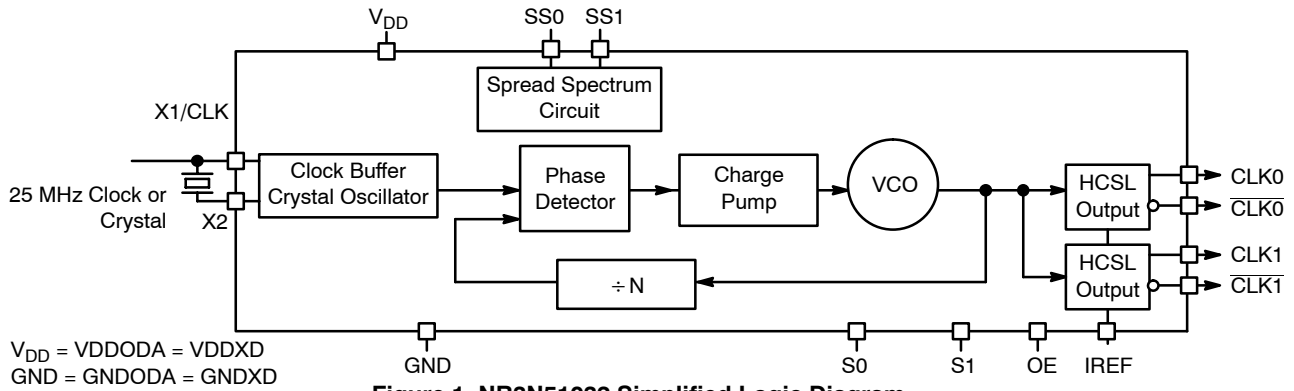

Figure 1. NB3N51032 Simplified Logic Diagram

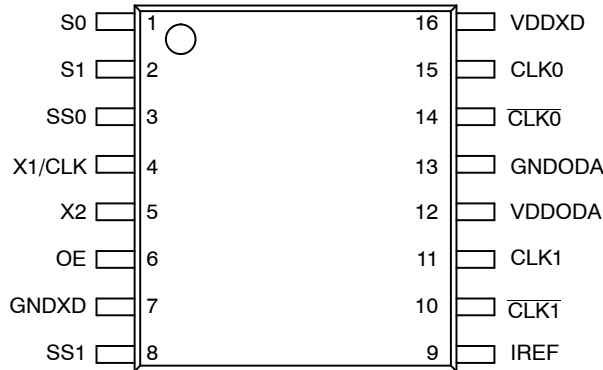

Figure 2. Pin Configuration (Top View)

Table 1. PIN DESCRIPTION

Pin	Symbol	I/O	Description
1	S0	Input	LVTTL/LVCMOS frequency select input 0. Internal pullup resistor to VDDXD. See output select table 2 for details.
2	S1	Input	LVTTL/LVCMOS frequency select input 1. Internal pullup resistor to VDDXD. See output select Table 2 for details.
3	SS0	Input	LVTTL/LVCMOS Spread select input 0. Internal pullup resistor to VDDXD. See Spread selection Table 3 for details.
4	X1/CLK	Input	Crystal or Clock input. Connect to 25 MHz crystal source or single-ended clock.
5	X2	Input	Crystal input. Connect to a 25 MHz crystal or leave unconnected for clock input.
6	OE	Input	Output enable. Tri-state output (High = enable outputs, Low = disable outputs). Internal pull-up resistor to VDDXD
7	GNDXD	Power Supply	Ground 0 V. This pin provides GND return path for the device.
8	SS1	Input	LVTTL/LVCMOS Spread select input 1. Internal pullup resistor to VDDXD. See Spread selection Table 3 for details.
9	IREF	Output	Output current reference pin. Precision resistor (typ. 475 Ω) is connected to set the output current.
10	$\overline{CLK1}$	HCSL or LVDS Output	Inverted clock output. (For LVDS levels see Figure 10)
11	CLK1	HCSL or LVDS Output	Noninverted clock output. (For LVDS levels see Figure 10)
12	VDDODA	Power Supply	Positive supply voltage pin connected to +3.3 V supply voltage.
13	GNDODA	Power Supply	Ground 0 V. These pins provide GND return path for the devices.
14	$\overline{CLK0}$	HCSL or LVDS Output	Inverted clock output. (For LVDS levels see Figure 10)
15	CLK0	HCSL or LVDS Output	Noninverted clock output. (For LVDS levels see Figure 10)
16	VDDXD	Power Supply	Positive supply voltage pin connected to +3.3 V supply voltage.

NB3N51032

Table 2. OUTPUT FREQUENCY SELECT TABLE WITH 25MHz CRYSTAL

S1*	S0*	CLK Multiplier	f _{CLKout} (MHz)
L	L	1x	25
L	H	4x	100
H	L	5x	125
H	H	8x	200

*Pins S1 and S0 default high when left open.

Recommended Crystal Parameters

Crystal	Fundamental AT-Cut
Frequency	25 MHz
Load Capacitance	16–20 pF
Shunt Capacitance, C0	7 pF Max
Equivalent Series Resistance	50 Ω Max
Initial Accuracy at 25 °C	±20 ppm
Temperature Stability	±30 ppm
Aging	±20 ppm

Table 3. SPREAD SELECTION TABLE

SS1*	SS0*	Spread%	Spread Type
0	0	No Spread	N/A
0	1	-0.5	Down
1	0	-0.75	Down
1	1	No Spread	N/A

*Pins S1 and S0 default high when left open.

Table 4. ATTRIBUTES

Characteristic	Value
ESD Protection Human Body Model	2 kV
Pull-up Resistor (Pins OE, S0, S1, SS0 and SS1)	50 kΩ
Moisture Sensitivity, Indefinite Time Out of Dry Pack (Note 1)	Level 1
Flammability Rating Oxygen Index: 28 to 34	UL 94 V-0 @ 0.125 in
Transistor Count	132000
Meets or exceeds JEDEC Spec EIA/JESD78 IC Latchup Test	

1. For additional information, see Application Note AND8003/D.

Table 5. MAXIMUM RATINGS (Note 2)

Symbol	Parameter	Rating	Unit
V _{DD}	Positive Power Supply with respect to GND (VDDXD and VDDODA)	4.6	V
V _I	Input Voltage with respect to GND (V _{IN})	-0.5 V to V _{DD} +0.5 V	V
T _A	Operating Temperature Range	-40 to +85	°C
T _{stg}	Storage Temperature Range	-65 to +150	°C
θ _{JA}	Thermal Resistance (Junction-to-Ambient) (Note 3)	0 lfpm 500 lfpm	°C/W °C/W
θ _{JC}	Thermal Resistance (Junction-to-Case)	50	°C/W
T _{sol}	Wave Solder	265	°C

Stresses exceeding those listed in the Maximum Ratings table may damage the device. If any of these limits are exceeded, device functionality should not be assumed, damage may occur and reliability may be affected.

2. Maximum ratings applied to the device are individual stress limit values (not normal operating conditions) and not valid simultaneously. If stress limits are exceeded device functional operation is not implied, damage may occur and reliability may be affected.

3. JEDEC standard multilayer board – 2S2P (2 signal, 2 power).

Table 6. DC CHARACTERISTICS (V_{DD} = 3.3 V ±5%, GND = 0 V, T_A = -40°C to +85°C, Note 4)

Symbol	Characteristic	Min	Typ	Max	Unit
V _{DD}	Power Supply Voltage (VDDXD and VDDODA)	3.135	3.3	3.465	V
GND	Power Supply Ground (GNDXD and GNDODA)		0		V
I _{DD}	Power Supply Current, 200 MHz Output, -0.75% spread		100		mA
I _{DDOE}	Power Supply Current when OE is Set Low		55		mA
V _{IH}	Input HIGH Voltage (X1/CLK, S0, S1, SS0, SS1 and OE)	2000		V _{DD} + 300	mV
V _{IL}	Input LOW Voltage (X1/CLK, S0, S1, SS0, SS1 and OE)	GND – 300		800	mV
V _{OH}	Output HIGH Voltage for HCSL Output (Note 5)	660		850	mV
V _{OL}	Output LOW Voltage for HCSL Output (Note 5)	-150	0		mV
V _{cross}	Crossing Voltage Magnitude (Absolute) for HCSL Output (Notes 6 and 7)	250		550	mV
ΔV _{cross}	Change in Magnitude of V _{cross} for HCSL Output (Notes 6 and 8)			150	mV

NOTE: Device will meet the specifications after thermal equilibrium has been established when mounted in a test socket or printed circuit board with maintained transverse airflow greater than 500 lfpm.

4. VDDXD and VDDODA power pins must be shorted to power supply voltage V_{DD} and GNDXD and GNDODA ground pins must be shorted to power supply ground GND. Measurement taken with outputs terminated with R_S = 33.2 Ω, R_L = 49.9 Ω, with test load capacitance of 2 pF and current biasing resistor set at 475 Ω. See Figure 9. Guaranteed by characterization.

5. Measurement taken from single-ended waveform.

6. Measured at crossing point where the instantaneous voltage value of the rising edge of CLKx+ equals the falling edge of CLKx-.

7. Refers to the total variation from the lowest crossing point to the highest, regardless of which edge is crossing. Refers to all crossing points for this measurement.

8. Defined as the total variation of all crossing voltage of rising CLKx+ and falling CLKx-. This is maximum allowed variance in the V_{CROSS} for any particular system.

NB3N51032

Table 7. AC CHARACTERISTICS ($V_{DD} = 3.3 \text{ V} \pm 5\%$, $GND = 0 \text{ V}$, $T_A = -40^\circ\text{C}$ to $+85^\circ\text{C}$; Note 9)

Symbol	Characteristic	Min	Typ	Max	Unit
f_{CLKIN}	Clock/Crystal Input Frequency		25		MHz
f_{CLKOUT}	Output Clock Frequency	25		200	MHz
Φ_{NOISE}	Phase-Noise Performance $f_{CLKOUT} = 100 \text{ Mhz}$ @ 100 Hz offset from carrier @ 1 kHz offset from carrier @ 10 kHz offset from carrier @ 100 kHz offset from carrier @ 1 MHz offset from carrier @ 10 MHz offset from carrier		-88 -118 -131 -132 -144 -155		dBc/Hz
t_{JITTER}	Period Jitter Peak-to-Peak (Note 10) Period Jitter RMS (Note 10) Cycle-Cycle RMS Jitter (Note 11) Cycle-to-Cycle Peak to Peak Jitter (Note 11)		$f_{CLKOUT} = 200 \text{ Mhz}$ 10 $f_{CLKOUT} = 200 \text{ MHz}$ 1.5 $f_{CLKOUT} = 200 \text{ MHz}$ 2.0 $f_{CLKOUT} = 200 \text{ MHz}$ 20	20 3.0 5.0 35	ps
$t_{JIT(\Phi)}$	Phase RMS Jitter, Integration Range 12 kHz to 20 MHz		0.5		ps
f_{MOD}	Spread Spectrum Modulation Frequency	30	31.5	33	kHz
SS_{RED}	Spectral Reduction, f_{CLKOUT} of 100 MHz with -0.5% spread, 3 rd Harmonic (Note 12)		-10		dB
t_{SKEW}	Within Device Output to Output Skew			40	ps
Eppm	Frequency Synthesis Error, All Outputs		0		ppm
t_{SPREAD}	Spread Spectruction Transition Time (Stabilization Time After Spread Spectrum Changes)	7		30	ms
t_{OE}	Output Enable/Disable Time (Note 13)			10	μs
t_{DUTY_CYCLE}	Output Clock Duty Cycle (Measured at cross point)	45	50	55	%
t_R	Output Risetime (Measured from 175 mV to 525 mV, Figure 11)	175		700	ps
t_F	Output Falltime (Measured from 525 mV to 175 mV, Figure 11)	175		700	ps
Δt_R	Output Risetime Variation (Single-Ended)			125	ps
Δt_F	Output Falltime Variation (Single-Ended)			125	ps
Stabilization Time	Stabilization Time From Powerup $V_{DD} = 3.3 \text{ V}$		3.0		ms

NOTE: Device will meet the specifications after thermal equilibrium has been established when mounted in a test socket or printed circuit board with maintained transverse airflow greater than 500 lfm.

9. VDDXD and VDDODA power pins must be shorted to power supply voltage V_{DD} and GNDXD and GNDODA ground pins must be shorted to power supply ground GND. Measurement taken from differential output on single-ended channel terminated with $R_S = 33.2 \Omega$, $R_L = 49.9 \Omega$, with test load capacitance of 2 pF and current biasing resistor set at 475 Ω . See Figure 9. Guaranteed by characterization.
10. Sampled with 10000 cycles.
11. Sampled with 1000 cycles.
12. Spread spectrum clocking enabled.
13. Output pins are tri-stated (Output disabled) when OE is asserted LOW. Output pins are driven differentially when OE is HIGH.

Table 8. AC ELECTRICAL CHARACTERISTICS – PCI EXPRESS JITTER SPECIFICATIONS,

$V_{DD} = 3.3\text{ V} \pm 5\%$, $T_A = -40^\circ\text{C}$ to 85°C

Symbol	Parameter	Test Conditions		Min	Typ	Max	PCIe Industry Spec	Unit
tj (PCIe Gen 1)	Phase Jitter Peak-to-Peak (Notes 15 and 18)	f = 100 MHz, 25 MHz Crystal Input Evaluation Band: 0 Hz – Nyquist (clock frequency/2)	SSOFF		10	20	86	pS
			SSON (-0.5%)		19	28		
tREFCLK_HF_RMS (PCIe Gen 2)	Phase Jitter RMS (Notes 16 and 18)	f = 100 MHz, 25 MHz Crystal Input High Band: 1.5 MHz – Nyquist (clock frequency/2)	SSOFF		1.0	1.8	3.1	pS
			SSON (-0.5%)		1.1	1.9		
tREFCLK_LF_RMS (PCIe Gen 2)	Phase Jitter RMS (Notes 16 and 18)	f = 100 MHz, 25 MHz Crystal Input Low Band: 10 kHz – 1.5 MHz	SSOFF		0.1	0.15	3	pS
			SSON (-0.5%)		0.8	1.1		
tREFCLK_RMS (PCIe Gen 3)	Phase Jitter RMS (Notes 17 and 18)	f = 100 MHz, 25 MHz Crystal Input Evaluation Band: 0 Hz – Nyquist (clock frequency/2)	SSOFF		0.35	0.7	1	pS
			SSON (-0.5%)		0.55	0.8		
tREFCLK_RMS (PCIe Gen 4)	Phase Jitter RMS (Notes 17 and 18)	f = 100 MHz, 25 MHz Crystal Input Evaluation Band: 0 Hz – Nyquist (clock frequency/2)	SSOFF		0.35	0.5	0.5	ps

14. Electrical parameters are guaranteed over the specified ambient operating temperature range, which is established when the device is mounted in a test socket with maintained transverse airflow greater than 500 lpm. The device will meet specifications after thermal equilibrium has been reached under these conditions.
15. Peak-to-Peak jitter after applying system transfer function for the Common Clock Architecture. Maximum limit for PCI Express Gen 1 is 86 ps peak-to-peak for a sample size of 10^6 clock periods.
16. RMS jitter after applying the two evaluation bands to the two transfer functions defined in the Common Clock Architecture and reporting the worst case results for each evaluation band. Maximum limit for PCI Express Generation 2 is 3.1 ps RMS for tREFCLK_HF_RMS (High Band) and 3.0 ps RMS for tREFCLK_LF_RMS (Low Band).
17. RMS jitter after applying system transfer function for the common clock architecture.
18. VDDXD and VDDODA power pins must be shorted to power supply voltage VDD and GNDXD and GNDODA ground pins must be shorted to power supply ground GND. Measurement taken from differential output on single-ended channel terminated with $R_S = 33.2\ \Omega$, $R_L = 50\ \Omega$, with test load capacitance of 2 pF and current biasing resistor set at 475 Ω . See Figure 11. This parameter is guaranteed by characterization. Not tested in production.

PHASE NOISE

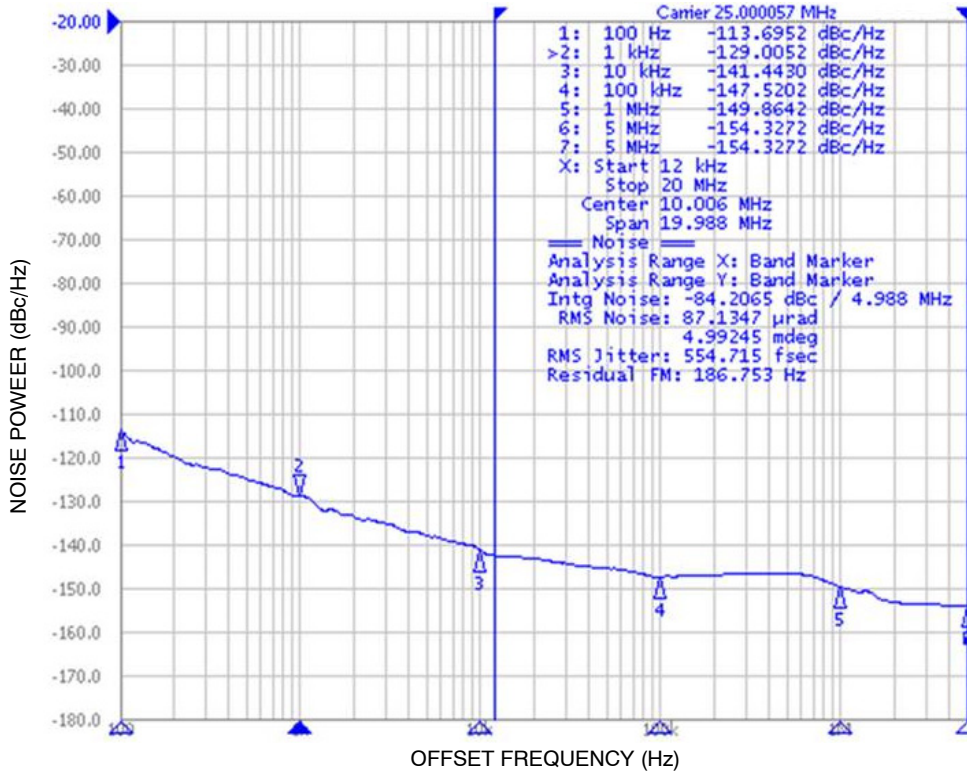

Figure 3. Typical Phase Noise Plot at 25 MHz; (f_{CLKIN} = 25 MHz Crystal , f_{CLKOUT} = 25 MHz SS OFF, RMS Phase Jitter for Integration Range 12 kHz to 20 MHz = 554 fs, Output Termination = HCSL type)

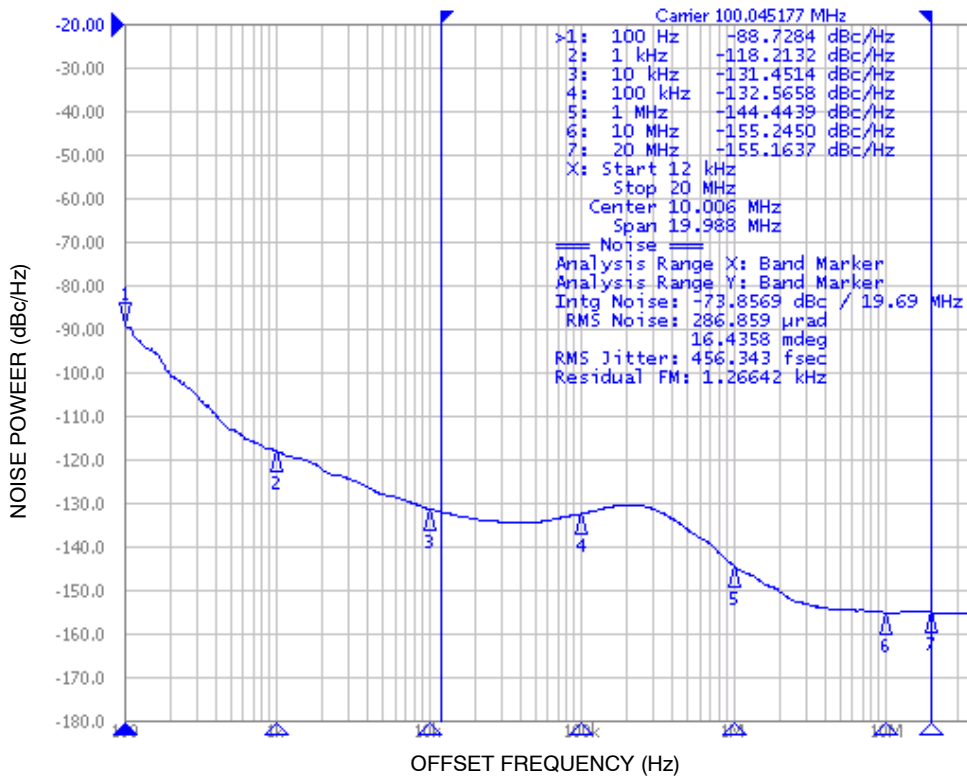

Figure 4. Typical Phase Noise Plot at 100 MHz; (f_{CLKIN} = 25 MHz Crystal , f_{CLKOUT} = 100 MHz SS OFF, RMS Phase Jitter for Integration Range 12 kHz to 20 MHz = 456 fs, Output Termination = HCSL type)

PHASE NOISE

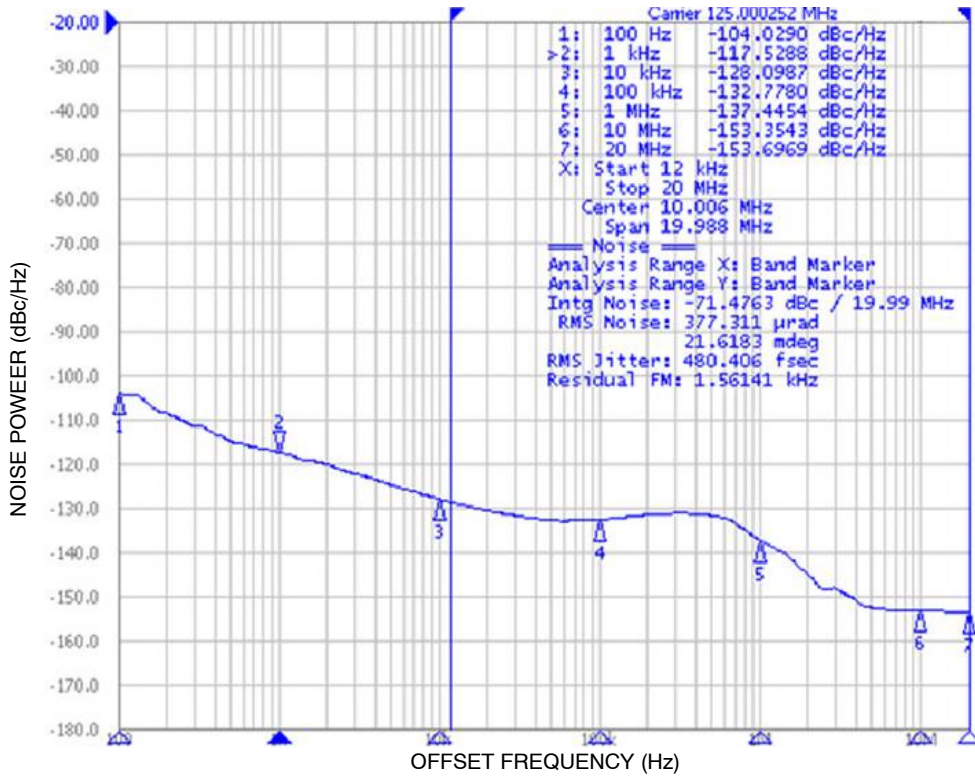

Figure 5. Typical Phase Noise Plot at 125 MHz; (f_{CLKIN} = 25 MHz Crystal , f_{CLKOUT} = 125 MHz SS OFF, RMS Phase Jitter for Integration Range 12 kHz to 20 MHz = 480 fs, Output Termination = HCSL type)

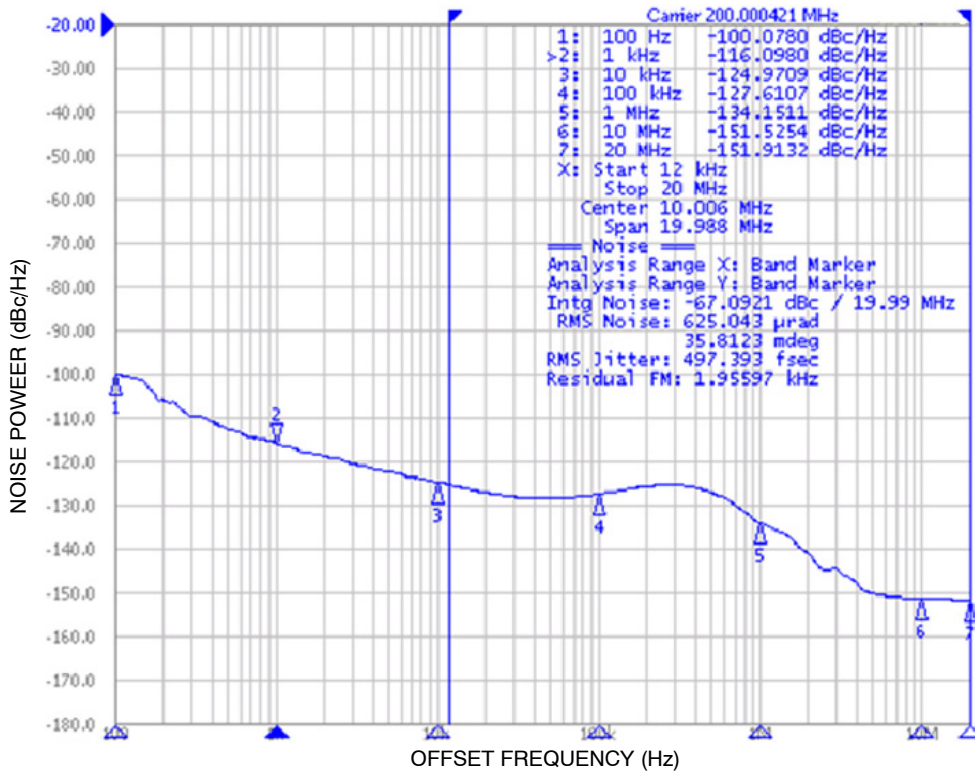

Figure 6. Typical Phase Noise Plot at 200 MHz; (f_{CLKIN} = 25 MHz Crystal , f_{CLKOUT} = 200 MHz SS OFF, RMS Phase Jitter for Integration Range 12 kHz to 20 MHz = 497 fs, Output Termination = HCSL type)

APPLICATION INFORMATION

Crystal Input Interface

Figure 7 shows the NB3N51032 device crystal oscillator interface using a typical parallel resonant crystal. The device crystal connections should include pads for small capacitors from X1 to ground and from X2 to ground. These capacitors, C_1 and C_2 , need to consider the stray capacitances of the board and are used to match the nominally required crystal load capacitance C_L . A parallel crystal with loading capacitance $C_L = 18 \text{ pF}$ would use $C_1 = 26 \text{ pF}$ and $C_2 = 26 \text{ pF}$

as nominal values, assuming approximately 2 pF of stray capacitance per trace and approximately 8 pF of internal capacitance.

$$C_L = (C_1 + C_{\text{stray}} + C_{\text{in}}) / 2; C_1 = C_2$$

The frequency accuracy and duty cycle skew can be fine-tuned by adjusting the C_1 and C_2 values. For example, increasing the C_1 and C_2 values will reduce the operational frequency.

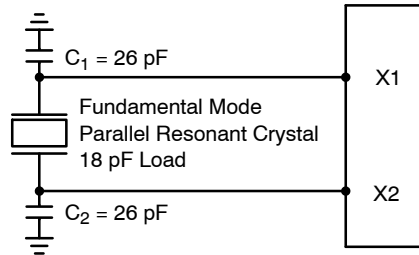

Figure 7. Crystal Interface Loading

Power Supply Filter

In order to isolate the NB3N51032 from system power supply, noise decoupling is required. The 10 μF and a 0.1 μF cap from supply pins to GND decoupling capacitor has to be connected between V_{DD} (pins 12 and 16) and GND (pins 7 and 13). It is recommended to place decoupling capacitors

as close as possible to the device to minimize lead inductance.

Termination

The output buffer structure is shown in the Figure 8.

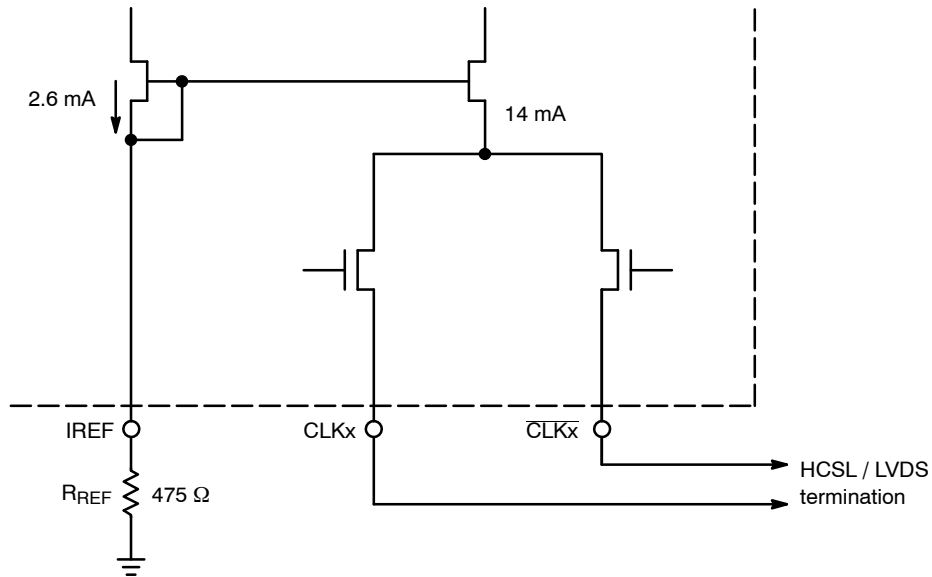

Figure 8. Simplified Output Structure

NB3N51032

The outputs can be terminated to drive HCSL receiver (see Figure 9) or LVDS receiver (see Figure 10). HCSL output interface requires $49.9\ \Omega$ termination resistors to GND for generating the output levels. LVDS output

interface may not require the $100\ \Omega$ near the LVDS receiver if the receiver has internal $100\ \Omega$ termination. An optional series resistor R_L may be connected to reduce the overshoots in case of impedance mismatch.

HCSL INTERFACE

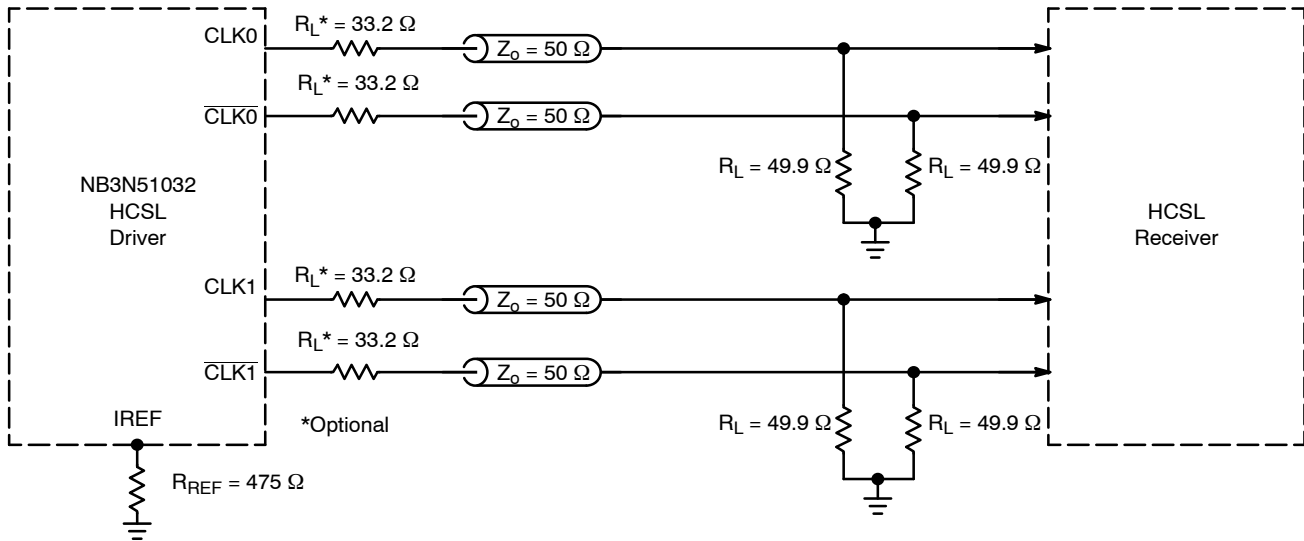

Figure 9. Typical Termination for Output Driver and Device Evaluation

LVDS COMPATIBLE INTERFACE

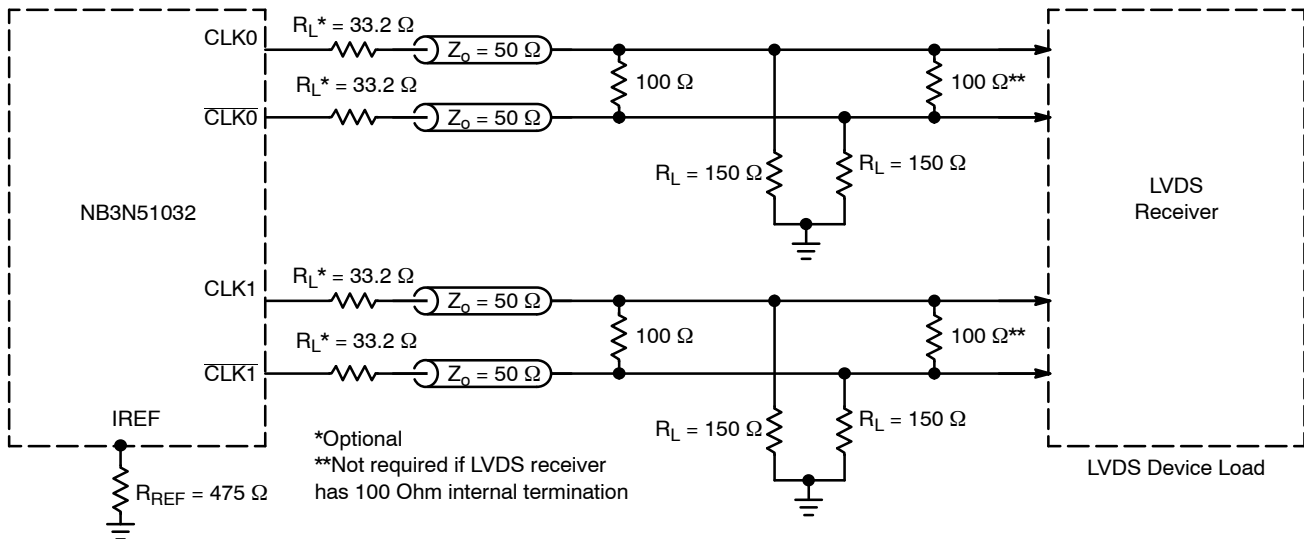

Figure 10. Typical Termination for LVDS Device Load

NB3N51032

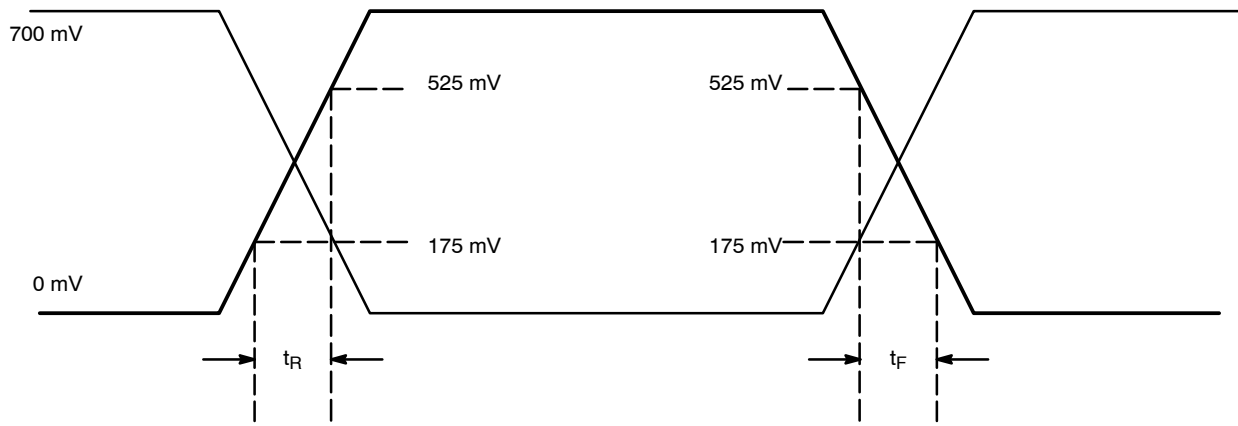

Figure 11. HCSL Output Parameter Characteristics

ORDERING INFORMATION

Device	Package	Shipping [†]
NB3N51032DTG	TSSOP-16 (Pb-Free)	96 Units / Rail
NB3N51032DTR2G	TSSOP-16 (Pb-Free)	2500 / Tape & Reel

[†]For information on tape and reel specifications, including part orientation and tape sizes, please refer to our Tape and Reel Packaging Specifications Brochure, BRD8011/D.

MECHANICAL CASE OUTLINE PACKAGE DIMENSIONS

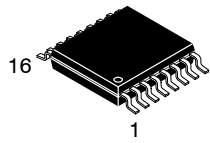

TSSOP-16 WB
CASE 948F
ISSUE B

DATE 19 OCT 2006

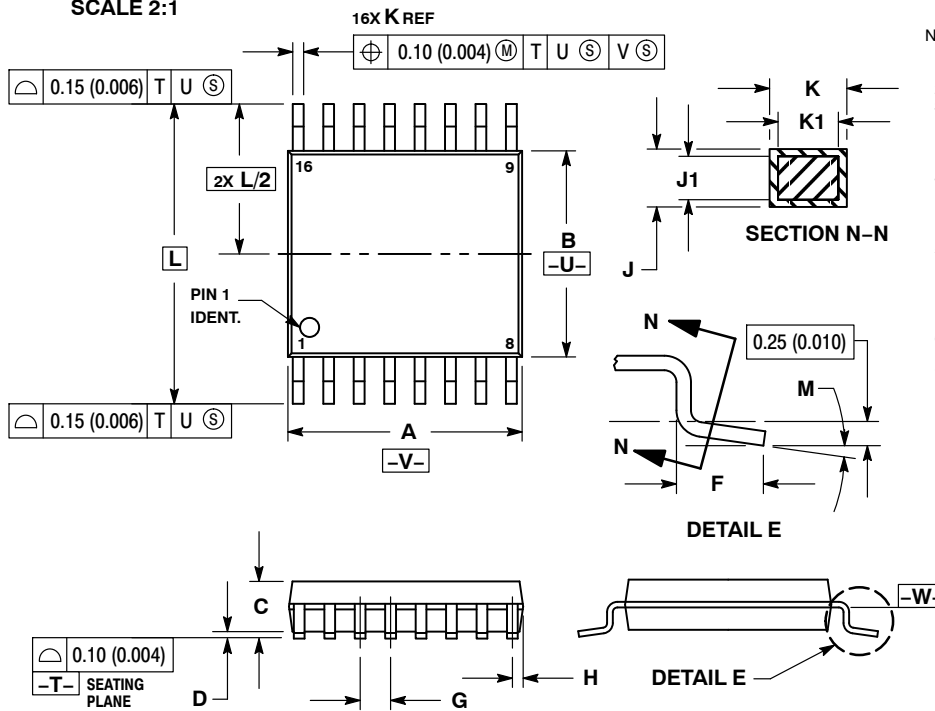

NOTES:

1. DIMENSIONING AND TOLERANCING PER ANSI Y14.5M, 1982.
2. CONTROLLING DIMENSION: MILLIMETER.
3. DIMENSION A DOES NOT INCLUDE MOLD FLASH, PROTRUSIONS OR GATE BURRS. MOLD FLASH OR GATE BURRS SHALL NOT EXCEED 0.15 (0.006) PER SIDE.
4. DIMENSION B DOES NOT INCLUDE INTERLEAD FLASH OR PROTRUSION. INTERLEAD FLASH OR PROTRUSION SHALL NOT EXCEED 0.25 (0.010) PER SIDE.
5. DIMENSION K DOES NOT INCLUDE DAMBAR PROTRUSION. ALLOWABLE DAMBAR PROTRUSION SHALL BE 0.08 (0.003) TOTAL IN EXCESS OF THE K DIMENSION AT MAXIMUM MATERIAL CONDITION.
6. TERMINAL NUMBERS ARE SHOWN FOR REFERENCE ONLY.
7. DIMENSION A AND B ARE TO BE DETERMINED AT DATUM PLANE -W-.

DIM	MILLIMETERS		INCHES	
	MIN	MAX	MIN	MAX
A	4.90	5.10	0.193	0.200
B	4.30	4.50	0.169	0.177
C	---	1.20	---	0.047
D	0.05	0.15	0.002	0.006
F	0.50	0.75	0.020	0.030
G	0.65 BSC		0.026 BSC	
H	0.18	0.28	0.007	0.011
J	0.09	0.20	0.004	0.008
J1	0.09	0.16	0.004	0.006
K	0.19	0.30	0.007	0.012
K1	0.19	0.25	0.007	0.010
L	6.40 BSC		0.252 BSC	
M	0°	8°	0°	8°

**RECOMMENDED
SOLDERING FOOTPRINT***

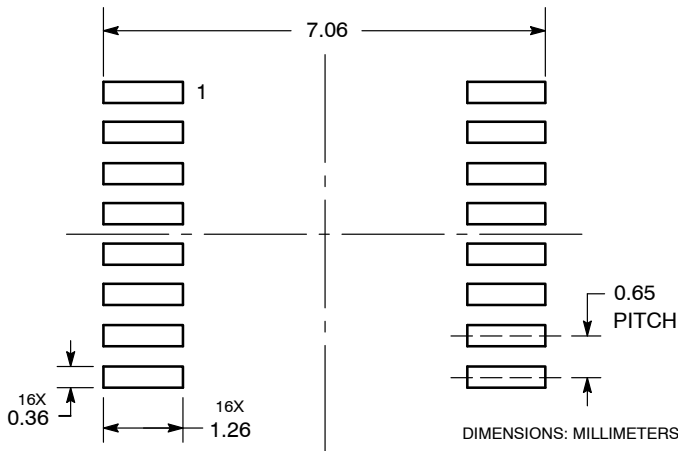

**GENERIC
MARKING DIAGRAM***

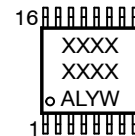

- XXXX = Specific Device Code
- A = Assembly Location
- L = Wafer Lot
- Y = Year
- W = Work Week
- G or ■ = Pb-Free Package

*This information is generic. Please refer to device data sheet for actual part marking. Pb-Free indicator, "G" or microdot "■", may or may not be present. Some products may not follow the Generic Marking.

*For additional information on our Pb-Free strategy and soldering details, please download the **onsemi** Soldering and Mounting Techniques Reference Manual, SOLDERRM/D.

DOCUMENT NUMBER:	98ASH70247A	Electronic versions are uncontrolled except when accessed directly from the Document Repository. Printed versions are uncontrolled except when stamped "CONTROLLED COPY" in red.
DESCRIPTION:	TSSOP-16	PAGE 1 OF 1

onsemi and onsemi are trademarks of Semiconductor Components Industries, LLC dba onsemi or its subsidiaries in the United States and/or other countries. onsemi reserves the right to make changes without further notice to any products herein. onsemi makes no warranty, representation or guarantee regarding the suitability of its products for any particular purpose, nor does onsemi assume any liability arising out of the application or use of any product or circuit, and specifically disclaims any and all liability, including without limitation special, consequential or incidental damages. onsemi does not convey any license under its patent rights nor the rights of others.

onsemi, **Onsemi**, and other names, marks, and brands are registered and/or common law trademarks of Semiconductor Components Industries, LLC dba "**onsemi**" or its affiliates and/or subsidiaries in the United States and/or other countries. **onsemi** owns the rights to a number of patents, trademarks, copyrights, trade secrets, and other intellectual property. A listing of **onsemi**'s product/patent coverage may be accessed at www.onsemi.com/site/pdf/Patent-Marking.pdf. **onsemi** reserves the right to make changes at any time to any products or information herein, without notice. The information herein is provided "as-is" and **onsemi** makes no warranty, representation or guarantee regarding the accuracy of the information, product features, availability, functionality, or suitability of its products for any particular purpose, nor does **onsemi** assume any liability arising out of the application or use of any product or circuit, and specifically disclaims any and all liability, including without limitation special, consequential or incidental damages. Buyer is responsible for its products and applications using **onsemi** products, including compliance with all laws, regulations and safety requirements or standards, regardless of any support or applications information provided by **onsemi**. "Typical" parameters which may be provided in **onsemi** data sheets and/or specifications can and do vary in different applications and actual performance may vary over time. All operating parameters, including "Typicals" must be validated for each customer application by customer's technical experts. **onsemi** does not convey any license under any of its intellectual property rights nor the rights of others. **onsemi** products are not designed, intended, or authorized for use as a critical component in life support systems or any FDA Class 3 medical devices or medical devices with a same or similar classification in a foreign jurisdiction or any devices intended for implantation in the human body. Should Buyer purchase or use **onsemi** products for any such unintended or unauthorized application, Buyer shall indemnify and hold **onsemi** and its officers, employees, subsidiaries, affiliates, and distributors harmless against all claims, costs, damages, and expenses, and reasonable attorney fees arising out of, directly or indirectly, any claim of personal injury or death associated with such unintended or unauthorized use, even if such claim alleges that **onsemi** was negligent regarding the design or manufacture of the part. **onsemi** is an Equal Opportunity/Affirmative Action Employer. This literature is subject to all applicable copyright laws and is not for resale in any manner.

ADDITIONAL INFORMATION

TECHNICAL PUBLICATIONS:



Technical Library: www.onsemi.com/design/resources/technical-documentation
onsemi Website: www.onsemi.com

ONLINE SUPPORT: www.onsemi.com/support

For additional information, please contact your local Sales Representative at www.onsemi.com/support/sales

Looking for pricing, stock, or lifecycle information?

Click below to explore more details on WIN SOURCE:

-  [View NB3N51032DTR2G on WIN SOURCE](#)
-  [ON Semiconductor](#) Information

Optimize Your Supply Chain with WIN SOURCE Solutions

-  Global Sourcing Solution
-  Obsolete Management
-  Cost Control Management
-  Shortage Management
-  Alternative Solution
-  Excess Inventory Management