



**THE DATASHEET OF  
S2GOPRESSUREDPS368TOB01**



# DPS368 Pressure Shield2Go

Quick Start  
V1.0.0



# Introduction

The DPS368 is a miniaturized digital barometric air pressure sensor with ultra-high precision ( $\pm 2$  cm) and a low current consumption, capable of measuring both pressure and temperature. Due to its robust package, it can withstand 50 m under water for one hour (IPx8). The pressure sensor element is based on a capacitive sensing principle which guarantees high precision during temperature changes. The small 2.0 x 2.5 x 1.1 mm package makes the DPS368 ideal for mobile applications and wearable devices. The internal signal processor converts the output from the pressure and temperature sensor elements to 24 bit results.

Each unit is individually calibrated, the calibration coefficients calculated during this process are stored in the calibration registers. The coefficients are used in the application to convert the measurement results to high accuracy pressure and temperature values.

The result FIFO can store up to 32 measurement results, allowing for a reduced host processor polling rate. Sensor measurements and calibration coefficients are available through the serial I<sup>2</sup>C or SPI interface.

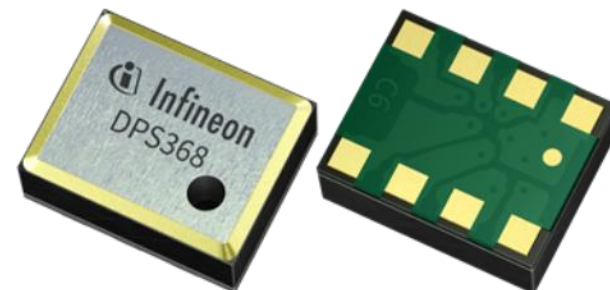

Link to [Datasheet](#) and [Product Page](#)

# Evaluation Board Notes

## Information

- Supply voltage is typ. 3.3 V, please refer to [DPS368 datasheet](#) for more details about maximum ratings
- Pin out on top (head) is directly connected to the pins of the DPS368
- If head is broken off, only two capacitors are connected to the DPS368
- Software compatible with Arduino and library fully integrated into the Arduino IDE
- Standard delivery of the board in terms of interface mode is I<sup>2</sup>C with 0x77 when the 0 Ohm resistors are soldered as shown on the right picture
- Sales Name S2GO PRESSURE DPS368 and OPN S2GOPRESSUREDPS368TOBO1

Breakable Head

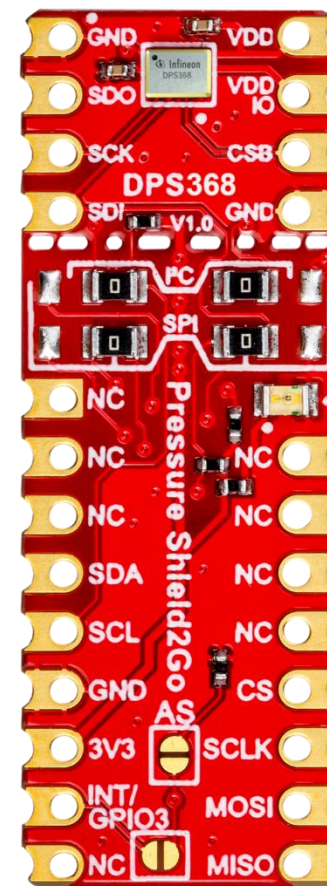

Ensure that no voltage applied to any of the pins exceeds the absolute maximum rating of 4 V

Link to [Board Page](#)

# Evaluation Board PCB Details

The

## DPS368 Pressure Shield2Go



**i** Ground pins on board connected with each other.

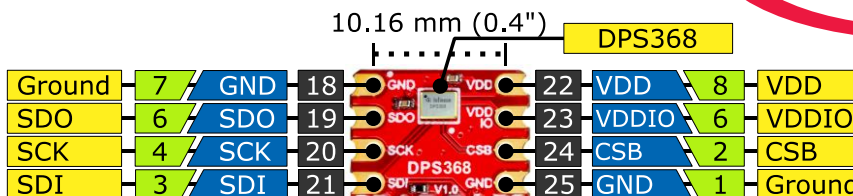

### Legend

- Information
- Labelling of Pins in Datasheet
- Pin Number in Datasheet
- Physical Pin Number
- Warning
- i** Additional Information
- NC Not Connected

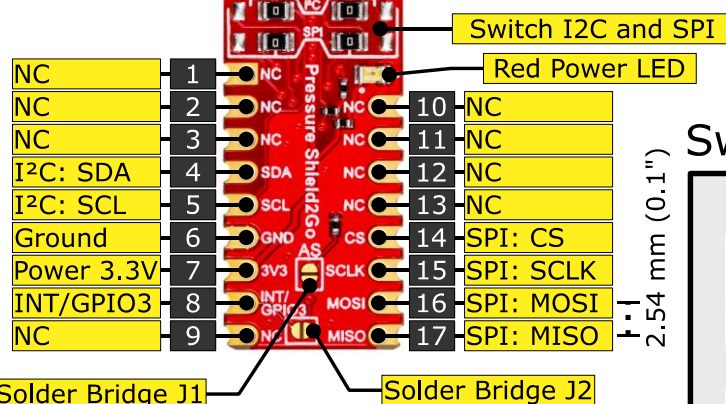

### Switch I<sup>2</sup>C/SPI

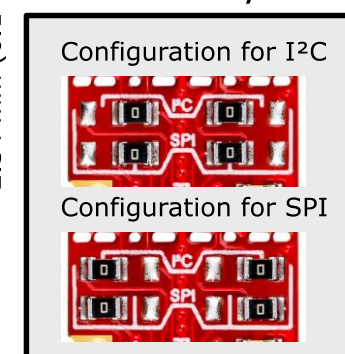

**i** The board can be switched from I<sup>2</sup>C mode to SPI mode by moving 0 Ohm resistors.

The maximum voltage on any pin is 4 V.

**i** Solder Bridge J1 enables pull-down resistor on interrupt pin and changes I<sup>2</sup>C address from 0x77 to 0x76.

**i** Solder Bridge J2 connects the interrupt pin to the INT/GPIO3 pin.

[www.infineon.com](http://www.infineon.com)

V1.0.0

# Evaluation Board Schematic

## SPI/I<sup>2</sup>C Selection Circuit

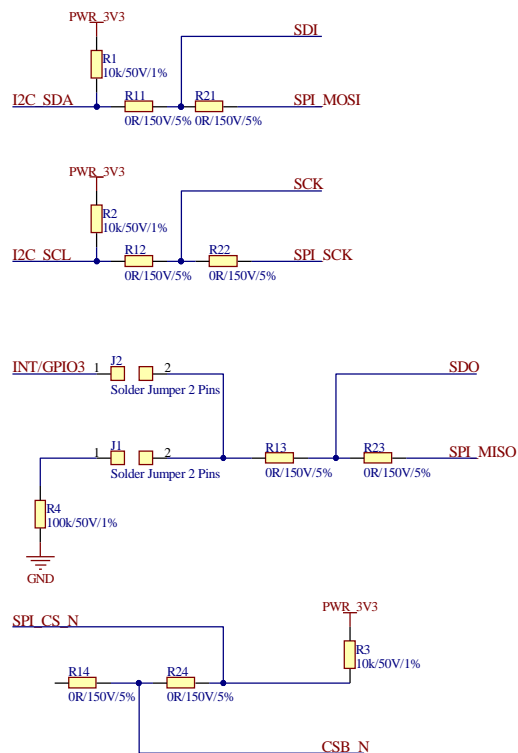

## DPS368

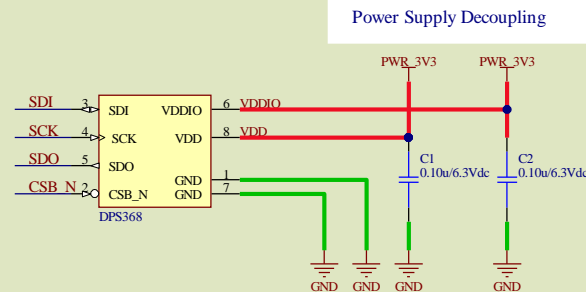

Green area: circuit if head is broken off

## Power Status LED

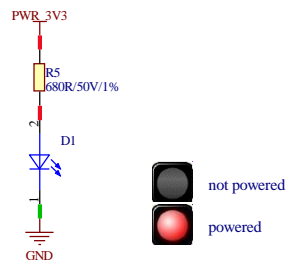

- I<sup>2</sup>C with optional interrupt: 0 Ohm R11, R12, R13, R14 are soldered)
- SPI 4 Wire: 0 Ohm resistors R21, R22, R23, R24 are soldered
- J1 Jumper - If soldered, enables the pull-down resistor on the interrupt pin and changes the I<sup>2</sup>C address from 0x77 to 0x76)
- J2 Jumper - Can be soldered to connect the INT/GPIO3 pin

# Arduino: The Arduino IDE

## Arduino IDE



Arduino is a hardware-software prototyping environment IDE developed by [arduino.cc](https://arduino.cc):

- Installation Details for Windows:  
Click [here](#)
- Installation Details for Linux:  
Click [here](#)
- Installation Details for Mac OS:  
Click [here](#)
- Installation Details for Portable IDE:  
Click [here](#)

## Arduino Quick Start

- What is Arduino? Click [here](#)
- Extended information about the Arduino environment. Click [here](#)
- How to import libraries? Click [here](#)
- How to install additional boards? Click [here](#)
- Problems related to Arduino? Click [here](#) for troubleshooting

# How to download the library for Arduino - 1

## Notes

- Open the Arduino IDE
- Navigate to *Sketch – Include Library – Manage Libraries*
- The Arduino library manager will be opened (see next slide for further instructions)
- Additional notes for installation can be found in the GitHub repository, e.g. if the library manager is not used

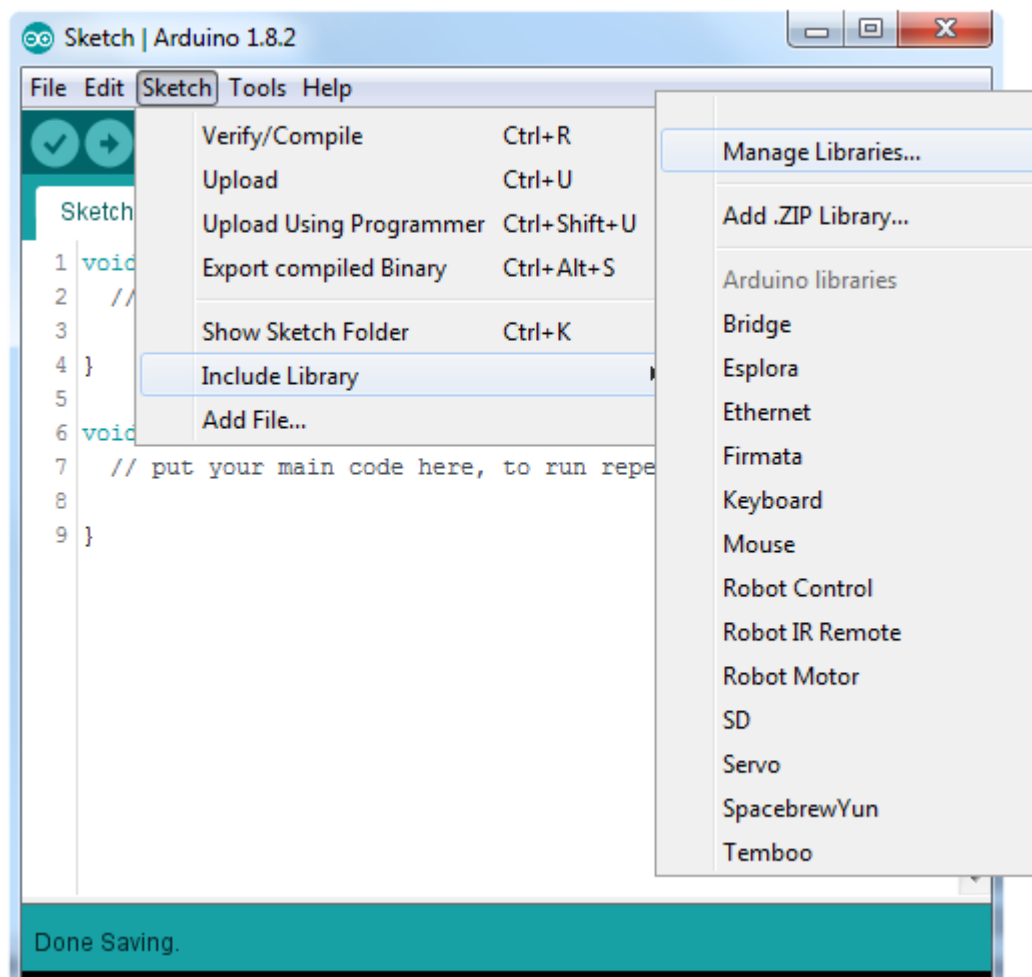

<https://github.com/Infineon/DPS368-Library-Arduino>

# How to download the library for Arduino - 2



## Notes

- The Arduino library manager is a comprehensive tool to install external libraries for Arduino
- Search for *DPS368* in the *Filter your search...* field
- Select as *Type: All* and *Topic: All* when searching for *DPS368*
- As shown in the picture, please choose the respective library and install it
- Regularly check your installed libraries for updates
- In case of problems, please visit also our [GitHub repository](https://github.com/Infineon/DPS368-Library-Arduino) and open an issue to get further help



<https://github.com/Infineon/DPS368-Library-Arduino>

# Example with XMC 2Go

## Notes

- The Shield2Go form factor of the Shield2Go evaluation board is directly compatible with the [XMC 2Go](#) board
- Stack the DPS368 Pressure Shield2Go board on top of the XMC 2Go as shown in the picture
- The additional pin on the left-top side (designated with NC) is not connected to the XMC 2Go board
- Using the [XMC-for-Arduino](#) Arduino integration, the [Arduino library](#) for the DPS368 can be directly used

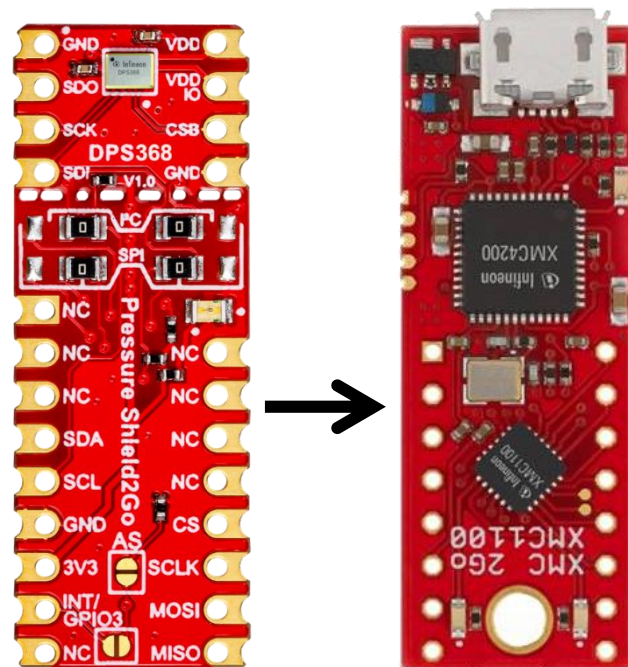

## Steps

- Open one of the examples for the DPS368 from *File – Examples* and select as board *XMC1100 XMC2Go*
- Connect the stacked boards to the PC and press the *Upload* button
- Select the related COM port from *Tools – Port* and open the serial monitor with the set baud rate (see sketch/code with `Serial.begin(<BAUDRATE>);`);

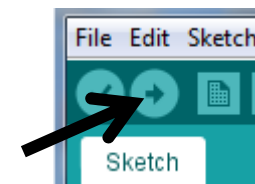

<https://github.com/Infineon/XMC-for-Arduino>  
<https://github.com/Infineon/DPS368-Library-Arduino>

# Important Warning

## Important Warning

- The DPS368 has a maximum rating of 4 V
- Third party boards with 5 V logic, e.g. the Arduino Uno, cannot be connected to the DPS368 Pressure Shield2Go board directly, even if the power is connected to the 3.3 V pin as the interface lines, e.g. SDA/SCL, will still be driven by 5 V
- Please use appropriate level shifting for these boards

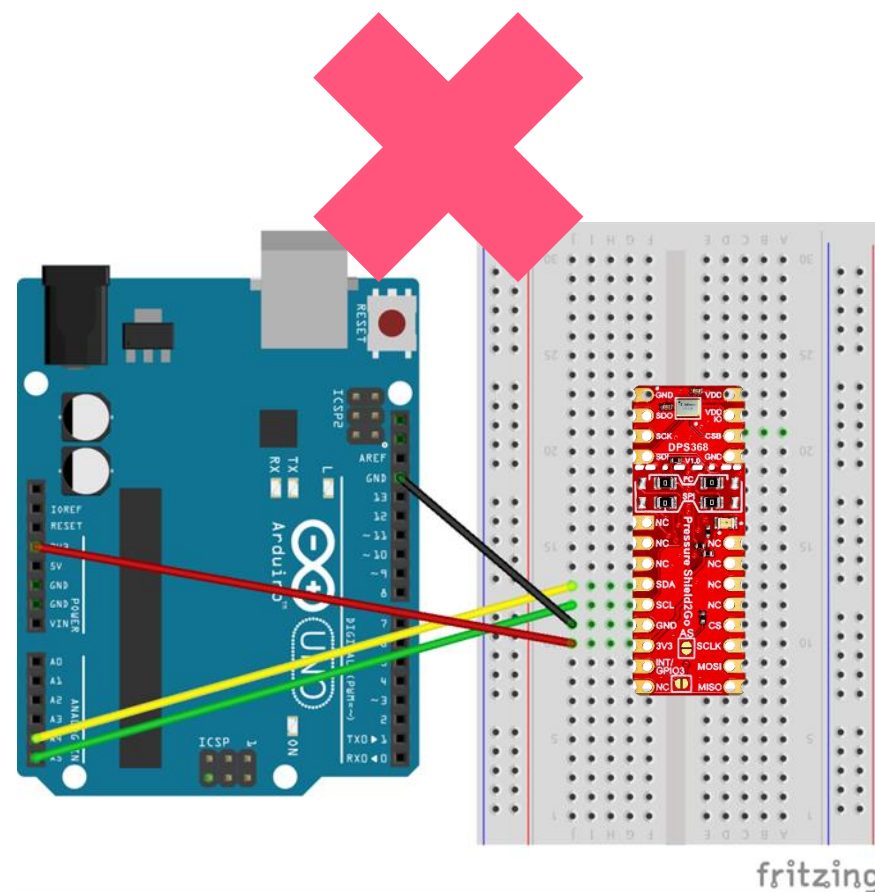

**Not possible**



Part of your life. Part of tomorrow.



## Looking for pricing, stock, or lifecycle information?

Click below to explore more details on WIN SOURCE:

- ⊖ [View S2GOPRESSUREDPS368TOBO1 on WIN SOURCE](#)
- ⊖ [Infineon Technologies](#) Information

## Optimize Your Supply Chain with WIN SOURCE Solutions

- ✓ Global Sourcing Solution
- ✓ Obsolete Management
- ✓ Cost Control Management
- ✓ Shortage Management
- ✓ Alternative Solution
- ✓ Excess Inventory Management