



**THE DATASHEET OF  
ISL54211IRTZ**



ISL54211

MP3/USB 2.0 High Speed Switch with Negative Signal Handling/Click and Pop Suppression

FN6662  
Rev 1.00  
August 25, 2008

The Intersil ISL54211 dual SPDT (Single Pole/Double Throw) switches combine low distortion audio and accurate USB 2.0 high speed data (480Mbps) signal switching in the same low voltage device. When operated with a 2.7V to 5.0V single supply these analog switches allow audio signal swings below-ground, allowing the use of a common USB and audio headphone connector in Personal Media Players and other portable battery powered devices.

The ISL54211 logic control pins are 1.8V compatible with a supply voltage of 2.7V to 3.6V, which allows for control via a standard  $\mu$ controller.

The part has an audio enable control pin (CTRL) to open all in-line switches and activate the audio click and pop circuitry. The high OFF-isolation and special click/pop circuitry of the audio switches eliminates click and pops in the head-phones when the audio CODEC drivers are powering up or down or when a headphone is inserted or removed from the headphone jack.

It's available in a tiny 10 Ld 1.8mmx1.4mm ultra-thin  $\mu$ TQFN package and a 10 Ld 3mmx3mm TDFN package. It operates over a temperature range of -40 to +85°C.

**Related Literature**

- Technical Brief TB363 "Guidelines for Handling and Processing Moisture Sensitive Surface Mount Devices (SMDs)"

**Features**

- High Speed (480Mbps) and Full Speed (12Mbps) Signaling Capability per USB 2.0
- Low Distortion Negative Signal Capability
- Clickless/Popless Audio Switches
- Enable Control Pin (CTRL) to Open all Switches
- Low Distortion Headphone Audio Signals
  - THD+N at 1mW into 32 $\Omega$  Load . . . . . 0.014%
- Crosstalk (20Hz to 20kHz) . . . . . -100dB
- OFF-Isolation (20Hz to 100kHz) . . . . . 95dB
- Single Supply Operation (V<sub>DD</sub>) . . . . . 2.7V to 5.0V
- -3dB Bandwidth USB Switch . . . . . 700MHz
- Available in  $\mu$ TQFN and TDFN Packages
- Compliant with USB 2.0 Short Circuit Requirements Without Additional External Components
- Pb-Free (RoHS Compliant)

**Applications**

- MP3 and other Personal Media Players
- Cellular/Mobile Phones
- PDA's
- Audio/USB Switching

**Application Block Diagram**

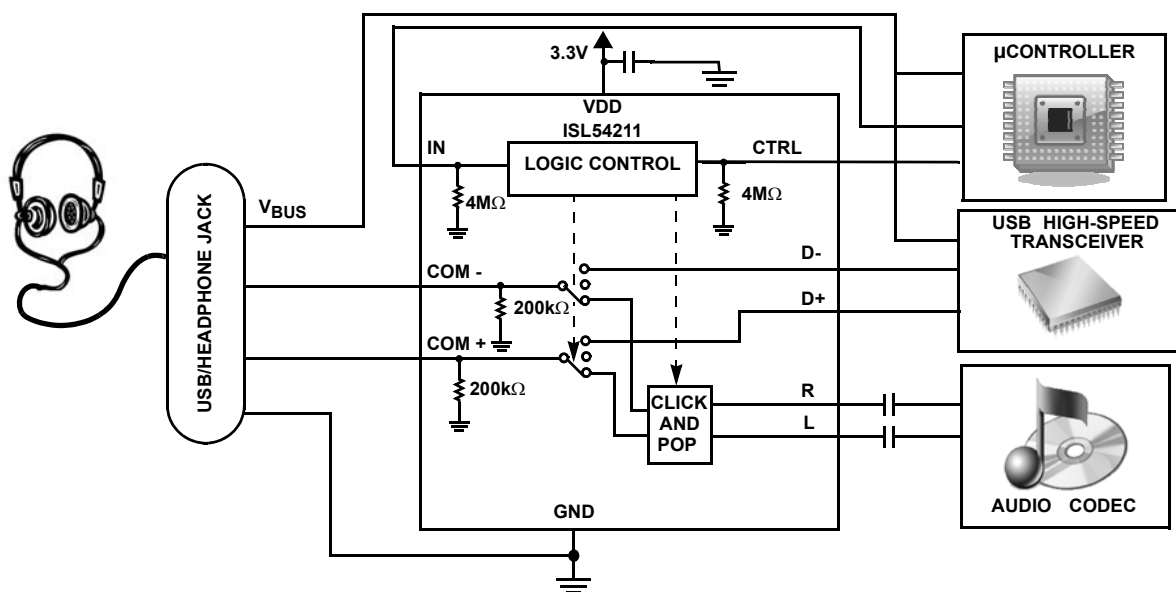

**Pinouts** (Note 1)

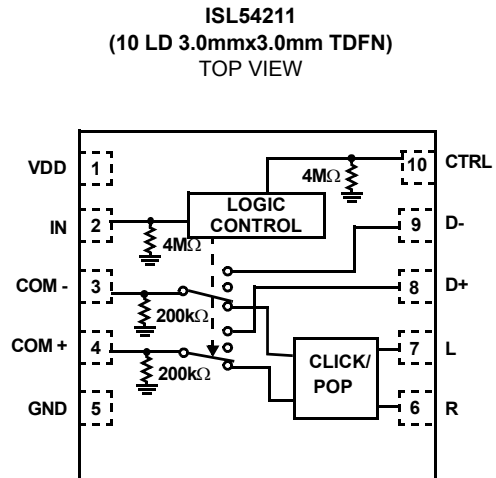
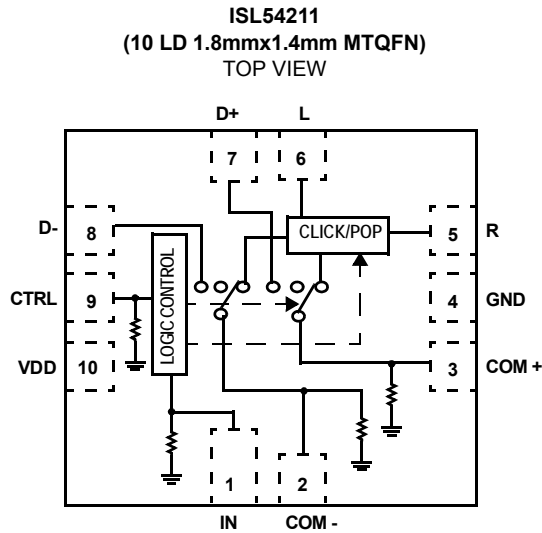

NOTE:

1. Switches Shown for IN = Logic "0" and CTRL = Logic "1".

**Truth Table**

ISL54211			
IN	CTRL	L, R	D+, D-
0	0	OFF	OFF
0	1	ON	OFF
1	X	OFF	ON

IN, CTRL: Logic "0" when  $\leq 0.5V$  or Floating, Logic "1" when  $\geq 1.4V$  with 2.7V to 3.6V supply.

**Pin Descriptions**

ISL54211			
$\mu$ TQFN	TDFN	NAME	FUNCTION
1	2	IN	Digital Control Input
2	3	COM-	Voice and Data Common Pin
3	4	COM+	Voice and Data Common Pin
4	5	GND	Ground Connection
5	6	R	Audio Right Input
6	7	L	Audio Left Input
7	8	D+	USB Differential Input
8	9	D-	USB Differential Input
9	10	CTRL	Digital Control Input (Audio Enable)
10	1	VDD	Power Supply

**Ordering Information**

PART NUMBER	PART MARKING	TEMP. RANGE (°C)	PACKAGE (Pb-Free)	PKG. DWG. #
ISL54211IRUZ-T* (Note 3)	1	-40 to +85	10 Ld 1.8x1.4mm $\mu$ TQFN	L10.1.8x1.4A
ISL54211IRTZ (Note 2)	4211	-40 to +85	10 Ld 3mmx3mm TDFN	L10.3x3A
ISL54211IRTZ-T* (Note 2)	4211	-40 to +85	10 Ld 3mmx3mm TDFN	L10.3x3A

\*Please refer to TB347 for details on reel specifications.

NOTES:

2. These Intersil Pb-free plastic packaged products employ special Pb-free material sets, molding compounds/die attach materials, and 100% matte tin plate plus anneal (e3 termination finish, which is RoHS compliant and compatible with both SnPb and Pb-free soldering operations). Intersil Pb-free products are MSL classified at Pb-free peak reflow temperatures that meet or exceed the Pb-free requirements of IPC/JEDEC J STD-020.
3. These Intersil Pb-free plastic packaged products employ special Pb-free material sets; molding compounds/die attach materials and NiPdAu plate - e4 termination finish, which is RoHS compliant and compatible with both SnPb and Pb-free soldering operations. Intersil Pb-free products are MSL classified at Pb-free peak reflow temperatures that meet or exceed the Pb-free requirements of IPC/JEDEC J STD-020.

**Absolute Maximum Ratings**

$V_{DD}$ to GND	-0.3V to 5.5V
Input Voltages	
D+, D-, L, R (Note 4)	-2V to ( $V_{DD}$ ) + 0.3V
IN (Note 4)	-2V to 5.5V
CTRL (Note 4)	-0.3 to ( $V_{DD}$ ) + 0.3V
Output Voltages	
COM-, COM+ (Note 4)	-2V to ( $V_{DD}$ ) + 0.3V
Continuous Current (Audio Switches)	±150mA
Peak Current (Audio Switches)	
(Pulsed 1ms, 10% Duty Cycle, Max)	±300mA
Continuous Current (USB Switches)	±40mA
Peak Current (USB Switches)	
(Pulsed 1ms, 10% Duty Cycle, Max)	±100mA
ESD Rating	
Human Body Model	6kV
Machine Model	300V
Charged Device Model	2kV

**Thermal Information**

Thermal Resistance (Typical)	$\theta_{JA}$ (°C/W)	$\theta_{JC}$ (°C/W)
10 Ld $\mu$ TQFN Package (Note 5)	160	N/A
10 Ld 3x3 TDFN Package (Notes 6, 7)	55	18
Maximum Junction Temperature (Plastic Package)	+150°C	
Maximum Storage Temperature Range	-65°C to +150°C	
Pb-Free Reflow Profile	see link below	
<a href="http://www.intersil.com/pbfree/Pb-FreeReflow.asp">http://www.intersil.com/pbfree/Pb-FreeReflow.asp</a>		

**Operating Conditions**

Temperature Range	-40°C to +85°C
-------------------	----------------

**CAUTION:** Do not operate at or near the maximum ratings listed for extended periods of time. Exposure to such conditions may adversely impact product reliability and result in failures not covered by warranty.

**NOTES:**

- Signals on D+, D-, L, R, COM-, COM+, CTRL, IN exceeding  $V_{DD}$  or GND by specified amount are clamped. Limit current to maximum current ratings.
- $\theta_{JA}$  is measured with the component mounted on a high effective thermal conductivity test board in free air. See Tech Brief TB379 for details.
- $\theta_{JA}$  is measured in free air with the component mounted on a high effective thermal conductivity test board with "direct attach" features. See Tech Brief TB379.
- For  $\theta_{JC}$ , the "case temp" location is the center of the exposed metal pad on the package underside.

**Electrical Specifications - 2.7V to 3.6V Supply** Test Conditions:  $V_{DD} = +3.0V$ ,  $GND = 0V$ ,  $V_{INH} = 1.4V$ ,  $V_{INL} = 0.5V$ ,  $V_{CTRLH} = 1.4V$ ,  $V_{CTRL} = 0.5V$ , (Note 8), Unless Otherwise Specified.

PARAMETER	TEST CONDITIONS	TEMP (°C)	MIN (Notes 9, 10)	TYP (Note 12)	MAX (Notes 9, 10)	UNITS
<b>ANALOG SWITCH CHARACTERISTICS</b>						
<b>Audio Switches (L, R)</b>						
Analog Signal Range, $V_{ANALOG}$	$V_{DD} = 2.7V$ to 3.6V, IN = float, CTRL = 1.4V	Full	-1.5	-	1.5	V
ON-Resistance, $r_{ON}$	$V_{DD} = 3.0V$ , IN = float, CTRL = 1.4V, $I_{COMx} = 40mA$ , $V_L$ or $V_R = -0.85V$ to 0.85V (see Figure 2)	+25	-	2.4	2.8	$\Omega$
$r_{ON}$ Matching Between Channels, $\Delta r_{ON}$	$V_{DD} = 3.0V$ , IN = 0.5V, CTRL = 1.4V, $I_{COMx} = 40mA$ , $V_L$ or $V_R =$ Voltage at max $r_{ON}$ over signal range of -0.85V to 0.85V, (Note 13)	+25	-	0.1	0.32	$\Omega$
		Full	-	-	0.4	$\Omega$
$r_{ON}$ Flatness, $R_{FLAT(ON)}$	$V_{DD} = 3.0V$ , IN = 0.5V, CTRL = 1.4V, $I_{COMx} = 40mA$ , $V_L$ or $V_R = -0.85V$ to 0.85V, (Note 11)	+25	-	0.02	0.06	$\Omega$
		Full	-	-	0.07	$\Omega$
Insertion Loss, $G_{ON}$	$V_{DD} = 3.0V$ , IN = 0.5V, CTRL = $V_{DD}$ , $R_{LOAD} = 32\Omega$	+25	-	-0.78	-	dB
Insertion Loss, $G_{ON}$	$V_{DD} = 3.0V$ , IN = 0.5V, CTRL = $V_{DD}$ , $R_{LOAD} = 15\Omega$	+25	-	-1.5	-	dB
Discharge Pull-Down Resistance, $R_L, R_R$	$V_{DD} = 3.6V$ , IN = 0.5V, CTRL = 0.5V, $V_{COM-}$ or $V_{COM+} = -0.85V, 0.85V$ , $V_L$ or $V_R = -0.85V, 0.85V$ , $V_{D+}$ and $V_{D-} =$ floating; measure current through the discharge pull-down resistor and calculate resistance value.	+25	-	40	-	$\Omega$
<b>USB Switches (D+, D-)</b>						
Analog Signal Range, $V_{ANALOG}$	$V_{DD} = 2.7V$ to 3.6V, IN = $V_{DD}$ , CTRL = 0V or $V_{DD}$	Full	0	-	$V_{DD}$	V
ON-Resistance, $r_{ON}$	$V_{DD} = 3.3V$ , IN = 1.4V, CTRL = 1.4V, $I_{COMx} = 1mA$ , $V_{D+}$ or $V_{D-} = 3.3V$ (see Figure 3)	+25	-	25	35	$\Omega$
		Full	-	-	40	$\Omega$

**Electrical Specifications - 2.7V to 3.6V Supply** Test Conditions:  $V_{DD} = +3.0V$ ,  $GND = 0V$ ,  $V_{INH} = 1.4V$ ,  $V_{INL} = 0.5V$ ,  
 $V_{CTRLH} = 1.4V$ ,  $V_{CTRL} = 0.5V$ , (Note 8), Unless Otherwise Specified. (Continued)

PARAMETER	TEST CONDITIONS	TEMP (°C)	MIN (Notes 9, 10)	TYP (Note 12)	MAX (Notes 9, 10)	UNITS
ON-Resistance, $r_{ON}$	$V_{DD} = 3.3V$ , $IN = 1.4V$ , $CTRL = 0V$ or $V_{DD}$ , $I_{COMx} = 40mA$ , $V_{D+}$ or $V_{D-} = 0V$ to $400mV$ (see Figure 3)	+25	-	5.4	6	$\Omega$
		Full	-	-	7.5	$\Omega$
$r_{ON}$ Matching Between Channels, $\Delta r_{ON}$	$V_{DD} = 3.3V$ , $IN = 1.4V$ , $CTRL = 0V$ or $V_{DD}$ , $I_{COMx} = 40mA$ , $V_{D+}$ or $V_{D-} =$ Voltage at max $r_{ON}$ , (Note 13)	+25	-	0.02	0.25	$\Omega$
		Full	-	-	0.25	$\Omega$
$r_{ON}$ Flatness, $R_{FLAT}(ON)$	$V_{DD} = 3.3V$ , $IN = 1.4V$ , $CTRL = 0V$ or $V_{DD}$ , $I_{COMx} = 40mA$ , $V_{D+}$ or $V_{D-} = 0V$ to $400mV$ , (Note 9)	+25	-	0.45	0.55	$\Omega$
		Full	-	-	0.6	$\Omega$
OFF Leakage Current, $I_{D+(OFF)}$ or $I_{D-(OFF)}$	$V_{DD} = 3.6V$ , $IN = 0V$ , $CTRL = 3.6V$ , $V_{COM-}$ or $V_{COM+} = 0.5V$ , $0V$ , $V_{D+}$ or $V_{D-} = 0V$ , $0.5V$ , $V_L$ and $V_R = float$	+25	-10	4	10	nA
		Full	-50	-	50	nA
ON Leakage Current, $I_{DX}$	$V_{DD} = 3.6V$ , $IN = V_{DD}$ , $CTRL = 0V$ or $V_{DD}$ , $V_{D+}$ or $V_{D-} = 2.7V$ , $V_{COM-}$ or $V_{COM+} = Float$ , $V_L$ and $V_R = float$ ; measuring current through 200k resistor at com side	+25	-20	11	20	$\mu A$
		Full	-30	-	30	$\mu A$
<b>DYNAMIC CHARACTERISTICS</b>						
USB Turn-ON Time, $t_{ON}$	$V_{DD} = 2.7V$ , $R_L = 50\Omega$ , $C_L = 10pF$ (see Figure 1)	+25	-	43	-	ns
USB Turn-OFF Time, $t_{OFF}$	$V_{DD} = 2.7V$ , $R_L = 50\Omega$ , $C_L = 10pF$ (see Figure 1)	+25	-	14.5	-	ns
Audio Turn-ON Time, $t_{ON}$	$V_{DD} = 2.7V$ , $R_L = 50\Omega$ , $C_L = 10pF$ (see Figure 1)	+25	-	7.5	-	$\mu s$
Audio Turn-OFF Time, $t_{OFF}$	$V_{DD} = 2.7V$ , $R_L = 50\Omega$ , $C_L = 10pF$ (see Figure 1)	+25	-	130	-	ns
Skew, $t_{SKEW}$	$V_{DD} = 3.0V$ , $IN = 3.0V$ , $CTRL = 0V$ or $3V$ , $R_L = 45\Omega$ , $C_L = 10pF$ , $t_R = t_F = 750ps$ at 480Mbps, (Duty Cycle = 50%) (see Figure 6)	+25	-	50	-	ps
Total Jitter, $t_j$	$V_{DD} = 3.0V$ , $IN = 3.0V$ , $CTRL = 0V$ or $3V$ , $R_L = 50\Omega$ , $C_L = 10pF$ , $t_R = t_F = 750ps$ at 480Mbps	+25	-	210	-	ps
Propagation Delay, $t_{PD}$	$V_{DD} = 3.0V$ , $IN = 3.0V$ , $CTRL = 0V$ or $3V$ , $R_L = 45\Omega$ , $C_L = 10pF$ (see Figure 6)	+25	-	250	-	ps
Audio Crosstalk R to COM-, L to COM+	$V_{DD} = 3.0V$ , $IN = float$ , $CTRL = 3.0V$ , $R_L = 32\Omega$ , $f = 20kHz$ to $20kHz$ , $V_R$ or $V_L = 0.707V_{RMS}$ ( $2V_{P-P}$ ) (see Figure 5)	+25	-	-100	-	dB
Crosstalk (Audio-to-USB, USB-to-Audio)	$V_{DD} = 3.0V$ , $R_L = 50\Omega$ , $f = 100kHz$ (see Figure 5)	+25	-	-100	-	dB
OFF-Isolation	$V_{DD} = 3.0V$ , $R_L = 50\Omega$ , $f = 100kHz$	+25	-	95	-	dB
	$V_{DD} = 3.0V$ , $R_L = 15\Omega$ , $f = 20Hz$ to $20kHz$	+25	-	111	-	dB
	$V_{DD} = 3.0V$ , $R_L = 32\Omega$ , $f = 20Hz$ to $20kHz$	+25	-	105	-	dB
	$V_{DD} = 3.0V$ , $R_L = 1k\Omega$ , $f = 20Hz$ to $20kHz$	+25	-	75	-	dB
	$V_{DD} = 3.0V$ , $R_L = 10k\Omega$ , $f = 20Hz$ to $20kHz$	+25	-	57	-	dB
	$V_{DD} = 3.0V$ , $R_L = 100k\Omega$ , $f = 20Hz$ to $20kHz$	+25	-	45	-	dB
Total Harmonic Distortion	$f = 20Hz$ to $20kHz$ , $V_{DD} = 3.0V$ , $IN = Float$ , $CTRL = 3.0V$ , $V_L$ or $V_R = 180mV_{RMS}$ ( $509mV_{P-P}$ ), $R_L = 32\Omega$	+25	-	0.014	-	%
	$f = 20Hz$ to $20kHz$ , $V_{DD} = 3.0V$ , $IN = Float$ , $CTRL = 3.0V$ , $V_L$ or $V_R = 0.707V_{RMS}$ ( $2V_{P-P}$ ), $R_L = 32\Omega$	+25	-	0.056	-	%
	$f = 20Hz$ to $20kHz$ , $V_{DD} = 3.0V$ , $IN = Float$ , $CTRL = 3.0V$ , $V_L$ or $V_R = 180mV_{RMS}$ ( $509mV_{P-P}$ ), $R_L = 15\Omega$	+25	-	0.043	-	%
	$f = 20Hz$ to $20kHz$ , $V_{DD} = 3.0V$ , $IN = Float$ , $CTRL = 3.0V$ , $V_L$ or $V_R = 0.707V_{RMS}$ ( $2V_{P-P}$ ), $R_L = 15\Omega$	+25	-	0.19	-	%
Click and Pop	$V_{DD} = 3.3V$ , $CTRL = 0V$ , $IN = float$ , $R_L = 1k\Omega$ , $V_L$ or $V_R = 0$ to $1.25V$ DC step or $1.25V$ to $0V$ DC step (see Figure 7)	+25	-	60	-	$\mu Vp$
	$V_{DD} = 3.3V$ , $CTRL = 0.5Hz$ Square Wave, $IN = float$ , $R_L = 30.1\Omega$ or $1k\Omega$ , $V_L$ or $V_R = AC$ -coupled to ground (see Figure 8)	+25	-	500	-	$\mu Vp$

**Electrical Specifications - 2.7V to 3.6V Supply** Test Conditions:  $V_{DD} = +3.0V$ ,  $GND = 0V$ ,  $V_{INH} = 1.4V$ ,  $V_{INL} = 0.5V$ ,  
 $V_{CTRLH} = 1.4V$ ,  $V_{CTRL} = 0.5V$ , (Note 8), Unless Otherwise Specified. **(Continued)**

PARAMETER	TEST CONDITIONS	TEMP (°C)	MIN (Notes 9, 10)	TYP (Note 12)	MAX (Notes 9, 10)	UNITS
USB Switch -3dB Bandwidth	Signal = 0dBm, 0.2VDC offset, $R_L = 50\Omega$ , $C_L = 5pF$	+25	-	700	-	MHz
D+/D- OFF Capacitance, $C_{D+OFF}$ , $C_{D-OFF}$	$f = 1MHz$ , $V_{DD} = 3.0V$ , $IN = float$ , $CTRL = 3.0V$ , $V_{D-}$ or $V_{D+} = V_{COMx} = 0V$ (see Figure 4)	+25	-	4	-	pF
COM ON Capacitance, $C_{COM-}$ (ON); $C_{COM+}$ (ON)	$f = 1MHz$ , $V_{DD} = 3.0V$ , $IN = 3.0V$ , $CTRL = 0V$ or $3V$ , $V_{D-}$ or $V_{D+} = V_{COMx} = 0V$ , (See Figure 4)	+25	-	9	-	pF
<b>POWER SUPPLY CHARACTERISTICS</b>						
Power Supply Range, $V_{DD}$		Full	2.7		3.6	V
Positive Supply Current, $I_{DD}$ (Audio Mode)	$V_{DD} = 3.6V$ , $IN = 0V$ , $CTRL = 3.6V$	+25	-	7	10	$\mu A$
		Full	-	-	12	$\mu A$
Positive Supply Current, $I_{DD}$ (USB Mode)	$V_{DD} = 3.6V$ , $IN = 3.6V$ , $CTRL = 3.6V$	+25	-	2.4	4	$\mu A$
		Full	-	-	5	$\mu A$
Positive Supply Current, $I_{DD}$ (Mute Mode)	$V_{DD} = 3.6V$ , $IN = 0V$ , $CTRL = 0V$	+25	-	2.4	4	$\mu A$
		Full	-	-	5	$\mu A$
<b>DIGITAL INPUT CHARACTERISTICS</b>						
IN Voltage Low, $V_{INL}$	$V_{DD} = 2.7V$ to $3.6V$	Full	-	-	0.5	V
IN Voltage High, $V_{INH}$	$V_{DD} = 2.7V$ to $3.6V$	Full	1.4	-	-	V
CTRL Voltage Low, $V_{CTRL}$	$V_{DD} = 2.7V$ to $3.6V$	Full	-	-	0.5	V
CTRL Voltage High, $V_{CTRLH}$	$V_{DD} = 2.7V$ to $3.6V$	Full	1.4	-	-	V
Input Current, $I_{INL}$ , $I_{CTRL}$	$V_{DD} = 3.6V$ , $IN = 0V$ or float, $CTRL = 0V$ or float	Full	-50	2	50	nA
Input Current, $I_{INH}$	$V_{DD} = 3.6V$ , $IN = 3.6V$ , $CTRL = 0V$ or float	Full	-2	1	2	$\mu A$
Input Current, $I_{CTRLH}$	$V_{DD} = 3.6V$ , $IN = 0V$ or float, $CTRL = 3.6V$	Full	-2	1	2	$\mu A$
IN Pull-Down Resistor, $R_{IN}$	$V_{DD} = 3.6V$ , $IN = 3.6V$ , $CTRL = 0V$ or float; measure current through the internal pull-down resistor and calculate resistance value.	Full	-	4	-	M $\Omega$
CTRL Pull-Down Resistor, $R_{CTRL}$	$V_{DD} = 3.6V$ , $IN = 0V$ or float, $CTRL = 3.6V$ ; measure current through the internal pull-down resistor and calculate resistance value.	Full	-	4	-	M $\Omega$

## NOTES:

8.  $V_{logic}$  = Input voltage to perform proper function.
9. The algebraic convention, whereby the most negative value is a minimum and the most positive a maximum, is used in this data sheet.
10. Parameters with MIN and/or MAX limits are 100% tested at +25°C, unless otherwise specified. Temperature limits established by characterization and are not production tested.
11. Flatness is defined as the difference between maximum and minimum value of ON-resistance over the specified analog signal range.
12. Limits established by characterization and are not production tested.
13.  $r_{ON}$  matching between channels is calculated by subtracting the channel with the highest max  $r_{ON}$  value from the channel with lowest max  $r_{ON}$  value, between L and R or between D+ and D-.

**Test Circuits and Waveforms**

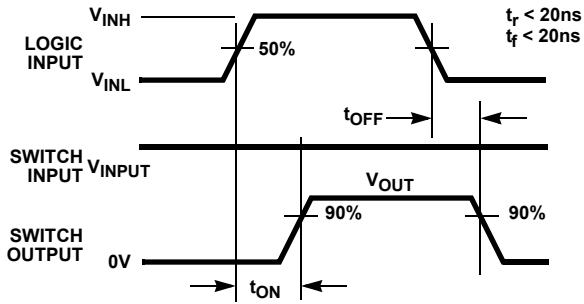

Logic input waveform is inverted for switches that have the opposite logic sense.

FIGURE 1A. MEASUREMENT POINTS

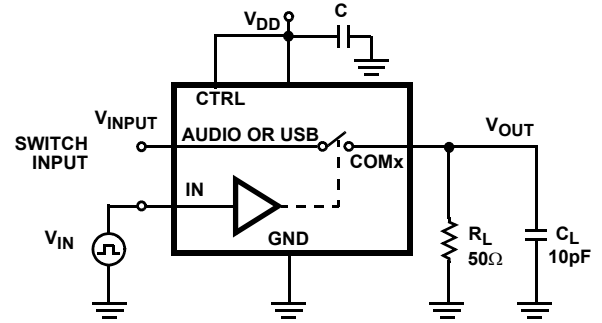

Repeat test for all switches.  $C_L$  includes fixture and stray capacitance.

$$V_{\text{OUT}} = V_{\text{(INPUT)}} \frac{R_L}{R_L + r_{\text{ON}}}$$

FIGURE 1B. TEST CIRCUIT

FIGURE 1. SWITCHING TIMES

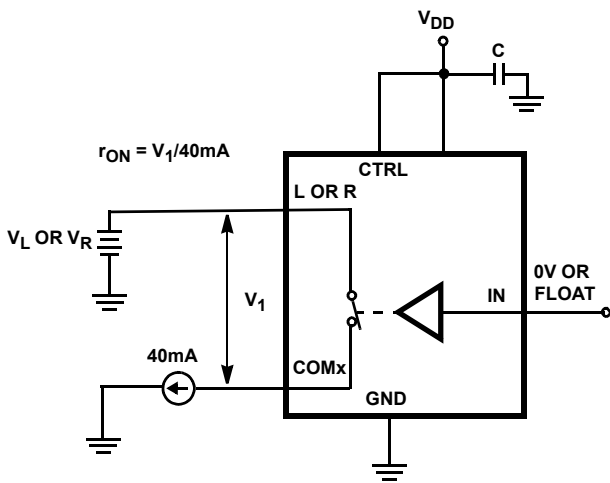

Repeat test for all switches.

FIGURE 2. AUDIO  $r_{\text{ON}}$  TEST CIRCUIT

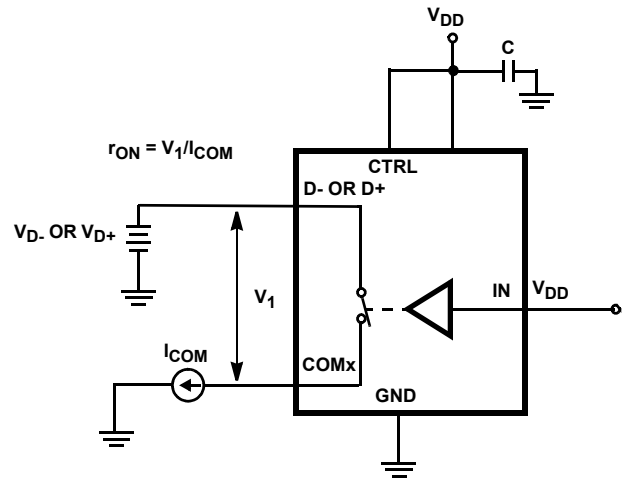

Repeat test for all switches.

FIGURE 3. USB  $r_{\text{ON}}$  TEST CIRCUIT

**Test Circuits and Waveforms** (Continued)

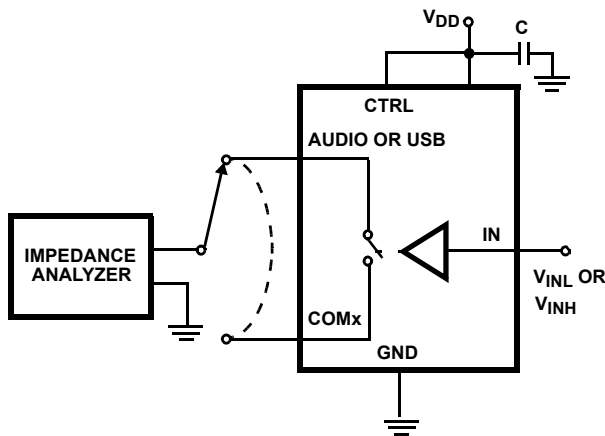

Repeat test for all switches.

**FIGURE 4. CAPACITANCE TEST CIRCUIT**

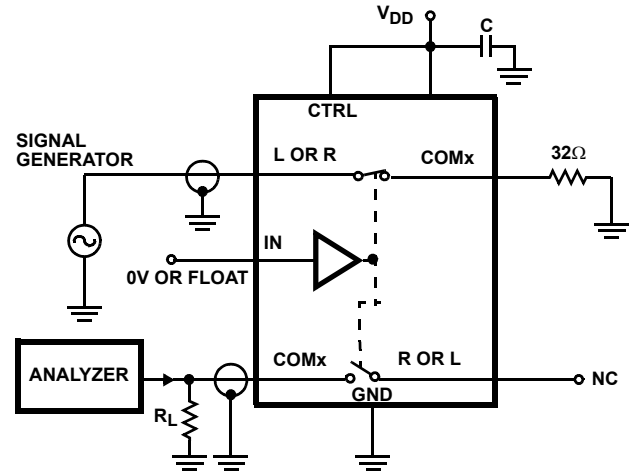

Repeat test for all switches.

**FIGURE 5. AUDIO CROSSTALK TEST CIRCUIT**

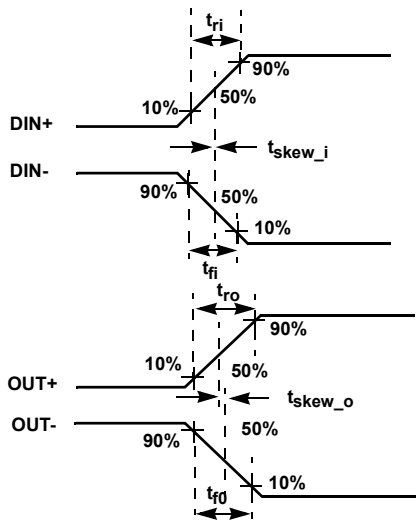

**FIGURE 6A. MEASUREMENT POINTS**

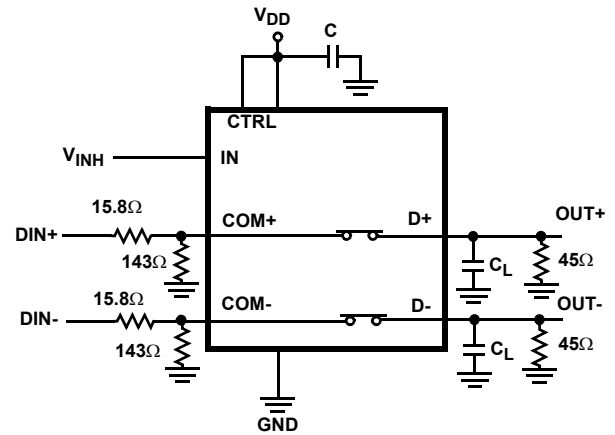

$|t_{ro} - t_{ri}|$  Delay Due to Switch for Rising Input and Rising Output Signals.  
 $|t_{fo} - t_{fi}|$  Delay Due to Switch for Falling Input and Falling Output Signals.  
 $|t_{skew_o}|$  Change in Skew through the Switch for Output Signals.  
 $|t_{skew_i}|$  Change in Skew through the Switch for Input Signals.

**FIGURE 6B. TEST CIRCUIT**

**FIGURE 6. SKEW TEST**

**Test Circuits and Waveforms** (Continued)

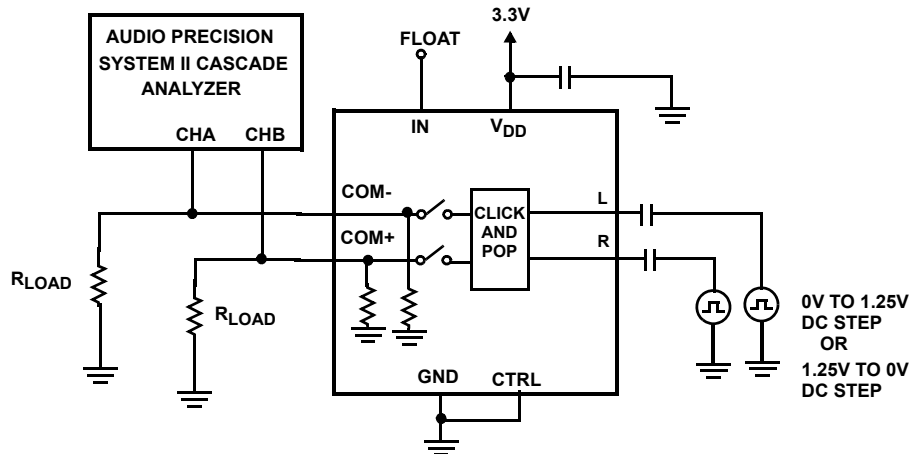

Set Audio Analyzer for Peak Detection, 32 Samples/Sec, Aweighted Filter, Manual Range 1X/Y, Units to dBV

**FIGURE 7. CLICK AND POP TEST CIRCUIT**

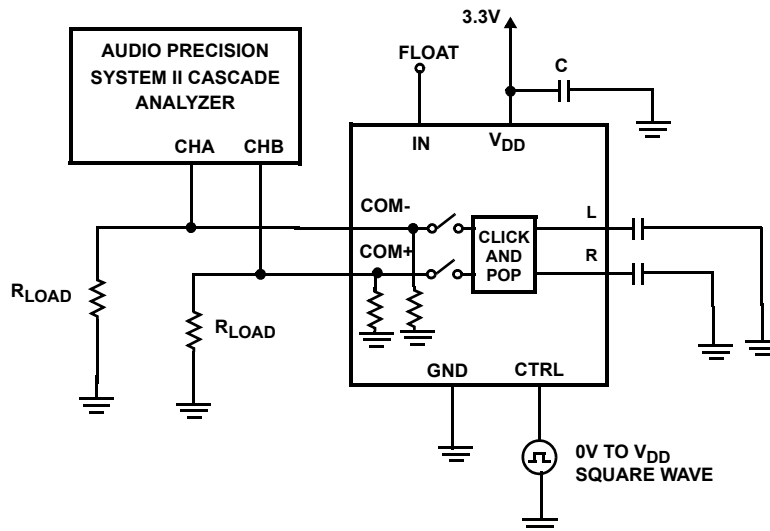

Set Audio Analyzer for Peak Detection, 32 Samples/Sec, Aweighted Filter, Manual Range 1X/Y, Units to dBV

**FIGURE 8. CLICK AND POP TEST CIRCUIT**

Power Supply Turn-On/Turn-Off Click and Pop Transient Test

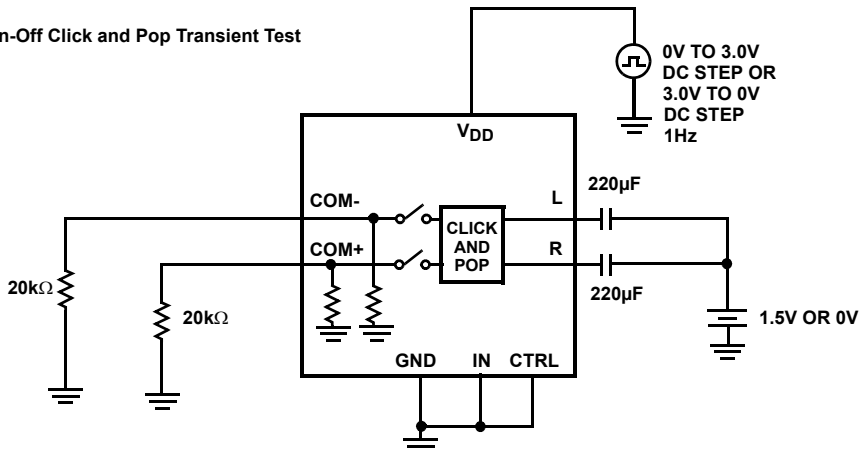

**FIGURE 9. CLICK AND POP TEST CIRCUIT #2**

## Typical Application Block Diagrams

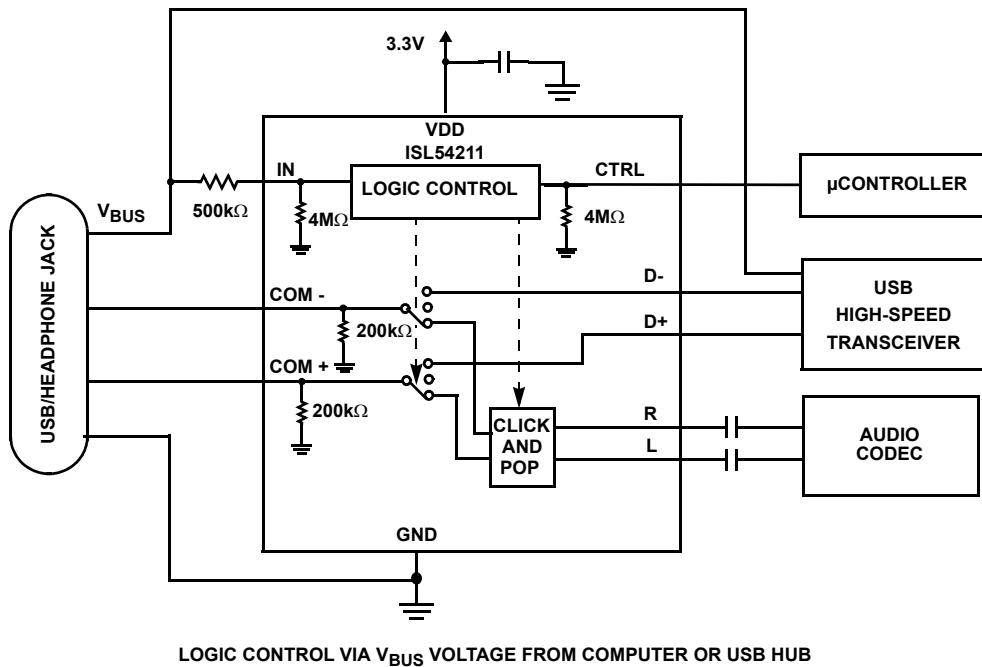
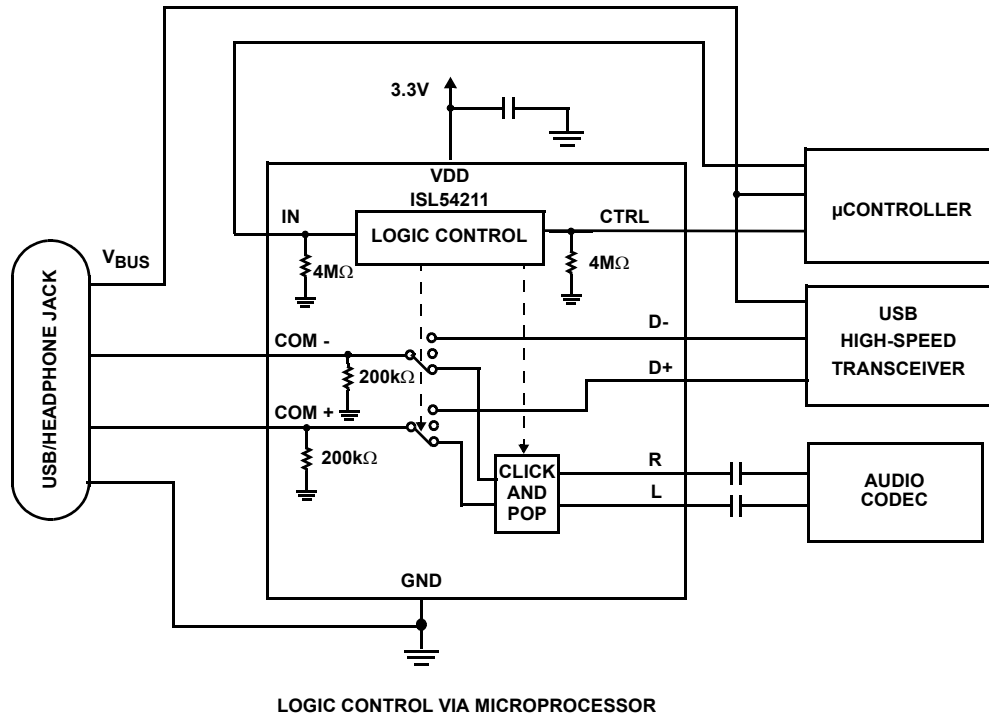

### Detailed Description

The ISL54211 device is a dual single pole/double throw (SPDT) analog switch that operates from a single DC power supply in the range of 2.7V to 5.0V. It was designed to function as dual 2-to-1 multiplexer to select between USB differential data signals and audio L and R stereo signals. It

comes in a tiny  $\mu$ TQFN package for use in MP3 players, PDAs, cellphones, and other personal media players.

The part consists of two  $2.5\Omega$  audio switches and two  $5.5\Omega$  USB switches. The audio switches can accept signals that swing below ground. They were designed to pass audio left and right stereo signals, that are ground referenced, with minimal distortion. The USB switches were designed to pass

high-speed USB differential data signals with minimal edge and phase distortion.

The ISL54211 was specifically designed for MP3 players, personal media players and cellphone applications that need to combine the audio headphone jack and the USB data connector into a single shared connector, thereby saving space and component cost. See “Typical Application Block Diagrams” on page 9 regarding functionality.

The ISL54211 has a single logic control pin (IN) that selects between the audio and the USB switches. This pin can be driven low or high to switch between the audio CODEC drivers and USB transceiver of the MP3 player or cellphone. The ISL54211 also contains a logic control pin (CTRL) that when driven low while IN is low, opens all switches and activates the audio click and pop circuitry.

A detailed description of the two types of switches are provided in the following sections. In a typical application, the USB transmission and audio playback are intended to be mutually exclusive operations.

### Audio Switches

The two audio switches (L, R) are  $2.5\Omega$  switches that can pass signals that swing below ground. Crosstalk between the audio switches is  $<-100\text{dB}$  over the audio band. These switches have excellent OFF-isolation  $>105\text{dB}$  over the audio band with a  $32\Omega$  load.

Over a signal range of  $\pm 1\text{V}$  ( $0.707V_{\text{RMS}}$ ) with  $V_{\text{DD}} > 2.7\text{V}$ , these switches have an extremely low  $r_{\text{ON}}$  resistance variation. They can pass ground referenced audio signals with very low distortion ( $<0.06\%$  THD+N) when delivering  $15.6\text{mW}$  into a  $32\Omega$  headphone speaker load. See Figures 16, 17, 18, and 19 (THD+N “Typical Performance Curves” beginning on page 12).

The audio drivers should be connected at the L and R side of the switch (pins 5 and 6 for  $\mu\text{TQFN}$ ; pins 6 and 7 for TDFN) and the speaker loads should be connected at the COM side of the switch (pins 2 and 3 for  $\mu\text{TQFN}$ ; pins 3 and 4 for TDFN). The switches have click and pop circuitry on the L and R side that is activated when the IN voltage is  $\leq 0.5\text{V}$  or floating and the CTRL voltage  $\leq 0.5\text{V}$  or floating. The ISL54211 should be put in this mode before powering down or powering up of the audio CODEC drivers. In this mode, both the audio and USB in-line switches will be OFF and the audio click and pop circuitry will be ON. The high OFF-isolation of the audio switches along with the click and pop circuitry will isolate the transients generated during power-up and power-down of the audio CODECs from getting through to the headphones, thus eliminating click and pop noise in the headphones.

The audio switches are active (turned ON) whenever the IN voltage is  $\leq 0.5\text{V}$  or floating and the CTRL voltage  $\geq 1.4\text{V}$ .

### USB Switches

The two USB switches (D+, D-) are  $5.5\Omega$  bidirectional switches that were specifically designed to pass high-speed USB differential signals typically in the range of  $0\text{V}$  to  $400\text{mV}$ . The switches have low capacitance and high bandwidth to pass USB high-speed signals ( $480\text{Mbps}$ ) with minimum edge and phase distortion to meet USB 2.0 signal quality specifications. See Figure 20 for High-speed Eye Pattern taken with the switch in the signal path.

These switches can also swing rail to rail and pass USB full-speed signals ( $12\text{Mbps}$ ) with minimal distortion. See Figure 21 for Full-speed Eye Pattern taken with the switch in the signal path.

The maximum signal range for the USB switches is from  $-1.5\text{V}$  to  $V_{\text{DD}}$ . The signal voltage at D- and D+ should not be allowed to exceed the  $V_{\text{DD}}$  voltage rail or go below ground by more than  $-1.5\text{V}$ .

The USB switches are active (turned ON) whenever the IN voltage is  $\geq 1.4\text{V}$ .

### ISL54211 Operation

The following sections discuss using the ISL54211 in the “Typical Application Block Diagrams” on page 9.

#### VDD SUPPLY

The DC power supply connected at VDD (pin 10 for  $\mu\text{TQFN}$ , pin 1 for TDFN) provides the required bias voltage for proper switch operation. The part can operate with a supply voltage in the range of  $2.7\text{V}$  to  $5.0\text{V}$ .

In a typical USB/Audio application for portable battery powered devices, the  $V_{\text{DD}}$  voltage will come from a battery or an LDO and be in the range of  $2.7\text{V}$  to  $4.3\text{V}$ . For best possible USB full-speed operation ( $12\text{Mbps}$ ), it is recommended that the  $V_{\text{DD}}$  voltage be  $\geq 2.7\text{V}$  in order to get a USB data signal level above  $2.7\text{V}$ .

#### LOGIC CONTROL

The state of the ISL54211 device is determined by the voltage at the IN pin (pin 1 for  $\mu\text{TQFN}$ ; pin 2 for TDFN) and the CTRL pin (pin 9 for  $\mu\text{TQFN}$ , pin 10 for TDFN). These logic pins are  $1.8\text{V}$  logic compatible when  $V_{\text{DD}}$  is in the range of  $2.7\text{V}$  to  $3.6\text{V}$  and can be controlled by a standard  $\mu\text{processor}$ . The part has three states or modes of operation: Audio Mode; USB Mode; and Mute Mode. Refer to “Truth Table” on page 2.

The IN pin and CTRL pin are internally pulled low through  $4\text{M}\Omega$  resistors to ground and can be left floating or tri-stated by the  $\mu\text{processor}$ . The CTRL control pin is only active when IN is logic “0”.

#### Logic Control Voltage Levels

IN = Logic “0” (Low) when  $\leq 0.5\text{V}$  or Floating.

IN = Logic “1” (High) when  $\geq 1.4\text{V}$

CTRL = Logic "0" (Low) when  $\leq 0.5V$  or Floating.

CTRL = Logic "1" (High) when  $\geq 1.4V$

### Audio Mode

If the IN pin = Logic "0" and CTRL pin = Logic "1" the part will be in the Audio mode. In Audio mode the L (left) and R (right)  $2.5\Omega$  audio switches are ON, the D- and D+  $5.5\Omega$  switches are OFF (high impedance) and the audio click and pop circuitry is OFF (high impedance).

When nothing is plugged into the common connector or a headphone is plugged into the common connector, the  $\mu$ processor will sense that there is no voltage at the VBUS pin of the connector and will drive and hold the IN control pin of the ISL54211 low. As long as the CTRL = Logic "1", the ISL54211 part remains in the audio mode and the audio drivers of the player can drive the headphones and play music.

### USB Mode

If the IN pin = Logic "1" and CTRL pin = Logic "0" or Logic "1", the part will go into USB mode. In USB mode the D- and D+  $5.5\Omega$  switches are ON and the L and R  $2.5\Omega$  audio switches are OFF (high impedance).

When a USB cable from a computer or USB hub is connected at the common connector, the  $\mu$ processor will sense the presence of the  $5V$  VBUS voltage and drive the IN pin voltage high. The ISL54211 part will go into the USB mode. In USB mode the computer or USB hub transceiver and the MP3 player or cellphone USB transceiver are connected and digital data will be able to be transmit back and forth.

When the USB cable is disconnected, the  $\mu$ processor will sense that the  $5V$  VBUS voltage is no longer connected and will drive the IN pin low and put the part back into the Audio or Mute mode.

### Mute Mode

If the IN pin = Logic "0" and CTRL pin = Logic "0", the part will be in the Mute mode. In the Mute mode, the audio switches and the USB switches are OFF (high impedance) and the audio click and pop circuitry is ON.

Before powering down or powering up of the audio CODECs drivers, the ISL54211 should be put in the Mute mode. In Mute mode, transients present at the L and R signal pins due to the changing DC voltage of the audio drivers will not pass to the headphones, preventing clicks and pops in the headphones.

Before power-up and power-down of the ISL54211, part the IN and CTRL control pins should be driven to ground or tri-stated. This will put the switch in the mute state, which turns all switches OFF and activates the click and pop circuitry. This will minimize transients at the speaker loads during power-up and power-down. See Figure 30 in the "Typical Performance Curves" on page 17.

### AC-COUPLED CLICK AND POP OPERATION

Single supply audio drivers have their signal biased at a DC offset voltage, usually at  $1/2$  the DC supply voltage of the driver. As this DC bias voltage comes up or goes down during power-up or power-down of the driver, a transient can be coupled into the speaker load through the DC blocking capacitor (see "Typical Application Block Diagrams" on page 9).

When a driver is OFF and suddenly turned ON, the rapidly changing DC bias voltage at the output of the driver will cause an equal voltage at the input side of the switch due to the fact that the voltage across the blocking capacitor cannot change instantly. If the switch is in the Audio mode or there is no low impedance path to discharge the blocking capacitor voltage at the input of the switch, before turning on the audio switch, a transient discharge will occur in the speaker, generating a click/pop noise.

Proper elimination of a click/pop transient at the speaker loads while powering up or down of the audio drivers requires that the ISL54211 have its click/pop circuitry activated by putting the part in the Mute mode. This allows the transients generated by the audio drivers to be discharged through the click and pop shunt circuitry.

Once the driver DC bias has reached  $V_{DD}/2$  and the transient on the switch side of the DC blocking capacitor has been discharged to ground through the click/pop shunt circuitry, the audio switches can be turned ON and connected through to the speaker loads without generating any undesirable click/pop noise in the speakers.

With a typical DC blocking capacitor of  $220\mu F$  and the click/pop shunt circuitry designed to have a resistance of  $20\Omega$  to  $70\Omega$ , allowing a  $100ms$  wait time to discharge the transient before placing the switch in the Audio mode will prevent the transient from getting through to the speaker load. See Figures 28 and 29 in the "Typical Performance Curves" page 16.

### USING THE COMPUTER VBUS VOLTAGE TO DRIVE THE "IN" PIN

Rather than using a micro-processor to control the IN logic pin, one can directly drive the IN pin using the VBUS voltage from the computer or USB hub. See the "Typical Application Block Diagrams" on page 9.

When a headphone or nothing is connected at the common connector, the internal  $4M\Omega$  pull-down will pull the IN pin low, putting the ISL54211 in the Audio or Mute mode, depending on the condition of the CTRL pin.

When a USB cable is connected at the common connector, the voltage at the IN pin will be driven to  $5V$  and the part will automatically go into the USB mode.

When the USB cable is disconnected from the common connector, the voltage at the IN pin will be pulled low by the

pull-down resistor and return to the Audio or Mute mode, depending on the condition of the CTRL pin.

Note: The ISL54211 contains an internal diode between the IN pin and VDD pin. Whenever the IN voltage is greater than the VDD voltage by more than 0.7V, current will flow through this diode into the VDD power supply bus. An external series resistor in the range of 100kΩ to 500kΩ is required at the IN logic pin to limit the current when driving it with the VBUS

voltage. This allows the VBUS voltage from a computer or USB hub (4.4V to 5.25V) to drive the IN pin while the VDD voltage is in the range of 2.7V to 3.6V. A 500kΩ resistor will limit the current to 3μA to 5μA and still allow the IN logic voltage to go to around 3V, which is will above the required VINH level of 1.4V. A smaller series resistor can be used but more current will flow.

**Typical Performance Curves**  $T_A = +25^\circ\text{C}$ , Unless Otherwise Specified

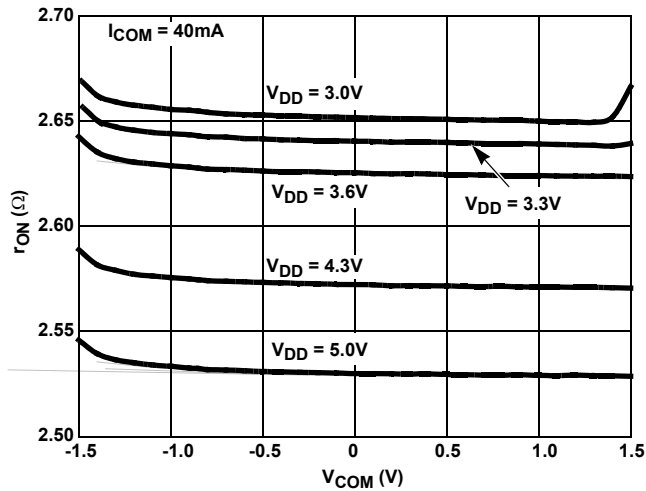

FIGURE 10. AUDIO ON-RESISTANCE vs SUPPLY VOLTAGE vs SWITCH VOLTAGE

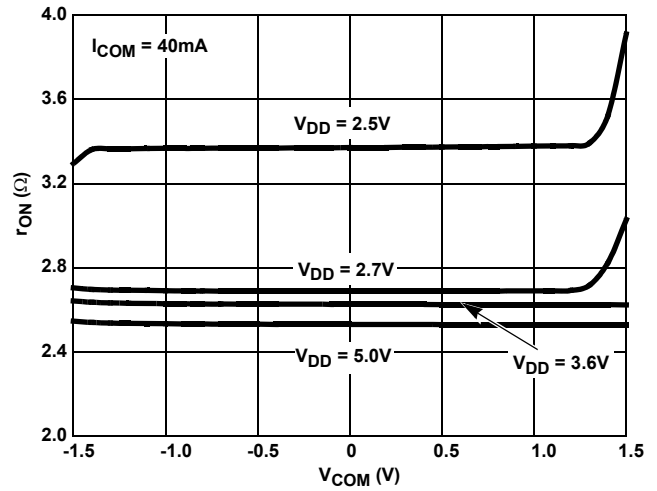

FIGURE 11. AUDIO ON-RESISTANCE vs SUPPLY VOLTAGE vs SWITCH VOLTAGE

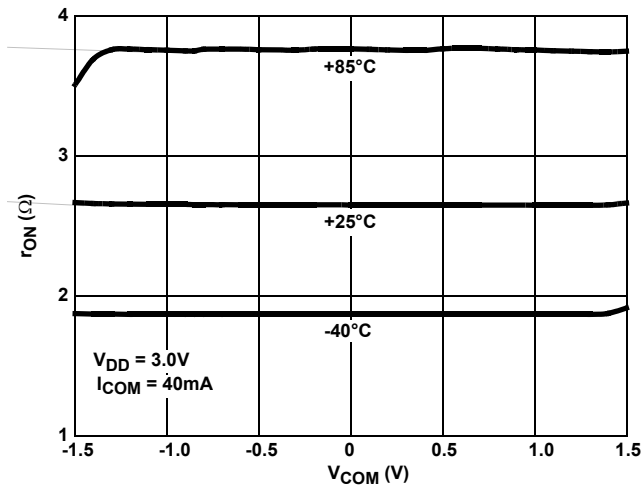

FIGURE 12. AUDIO ON-RESISTANCE vs SWITCH VOLTAGE vs TEMPERATURE

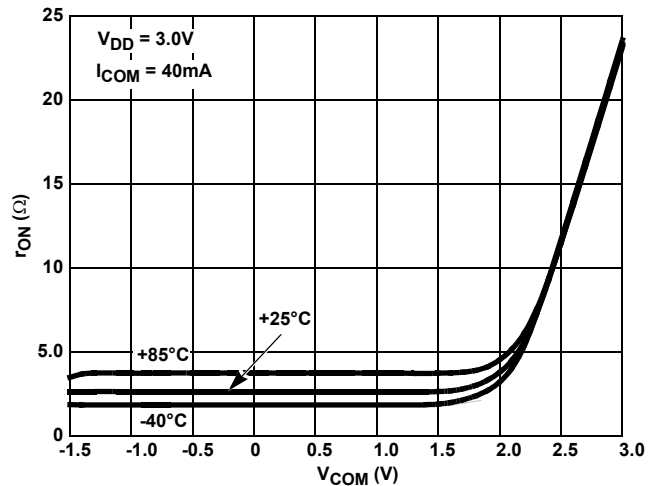

FIGURE 13. AUDIO ON-RESISTANCE vs SWITCH VOLTAGE vs TEMPERATURE

**Typical Performance Curves**  $T_A = +25^\circ\text{C}$ , Unless Otherwise Specified (Continued)

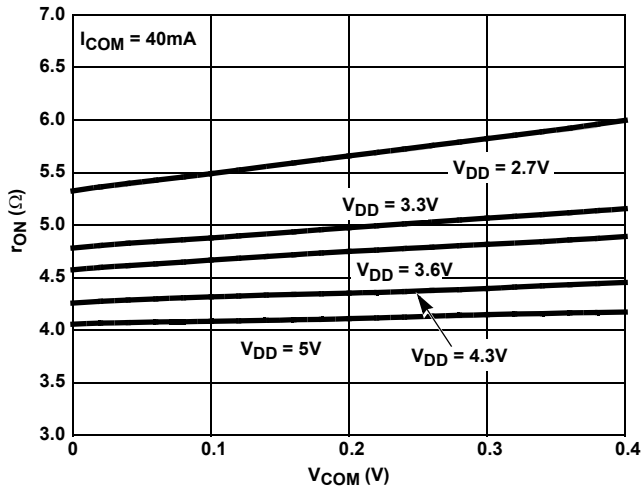

FIGURE 14. USB ON-RESISTANCE vs SUPPLY VOLTAGE vs SWITCH VOLTAGE

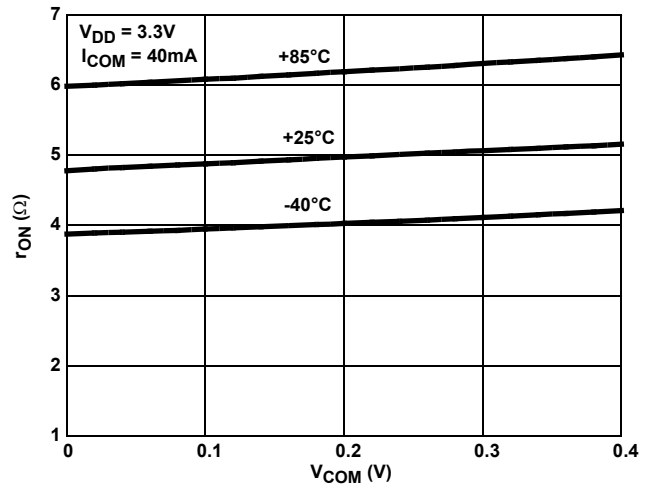

FIGURE 15. USB ON-RESISTANCE vs SWITCH VOLTAGE vs TEMPERATURE

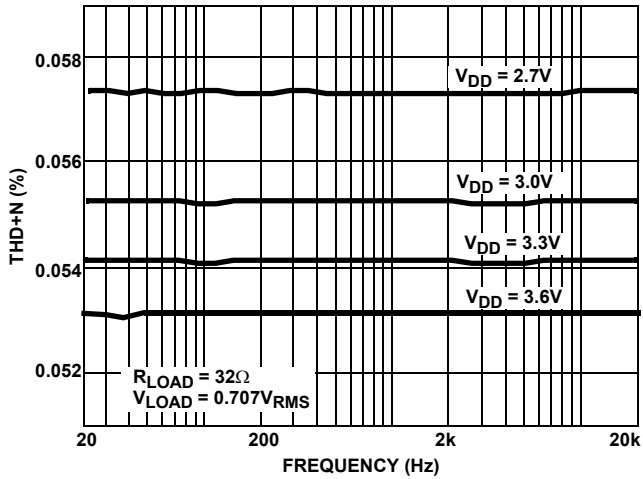

FIGURE 16. THD+N vs SUPPLY VOLTAGE vs FREQUENCY

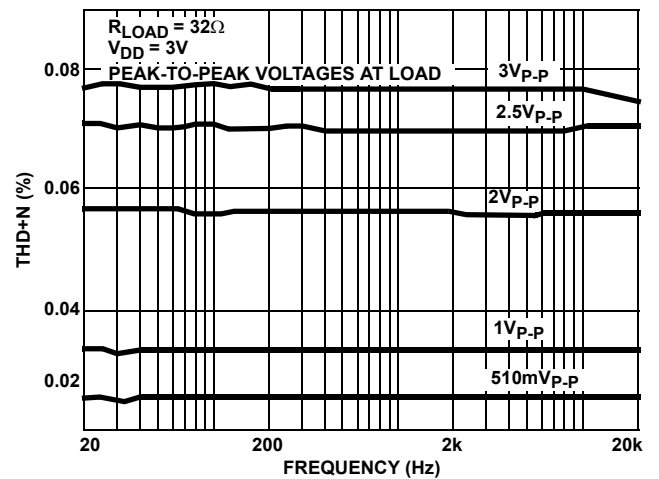

FIGURE 17. THD+N vs SIGNAL LEVELS vs FREQUENCY

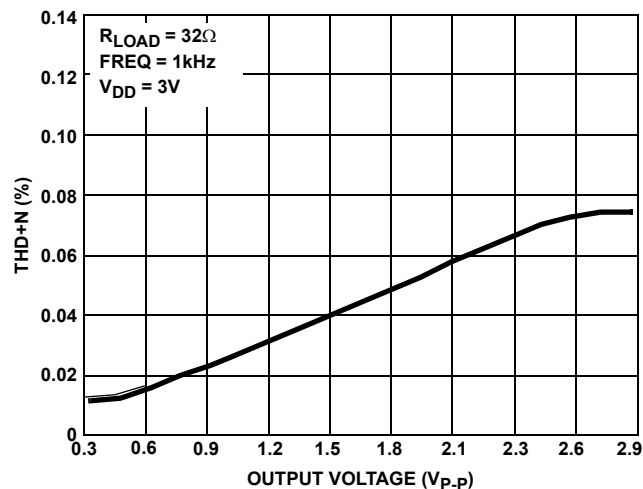

FIGURE 18. THD+N vs OUTPUT VOLTAGE

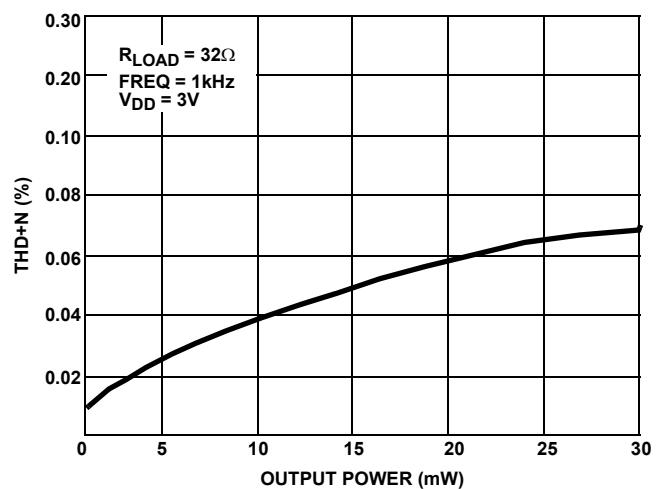
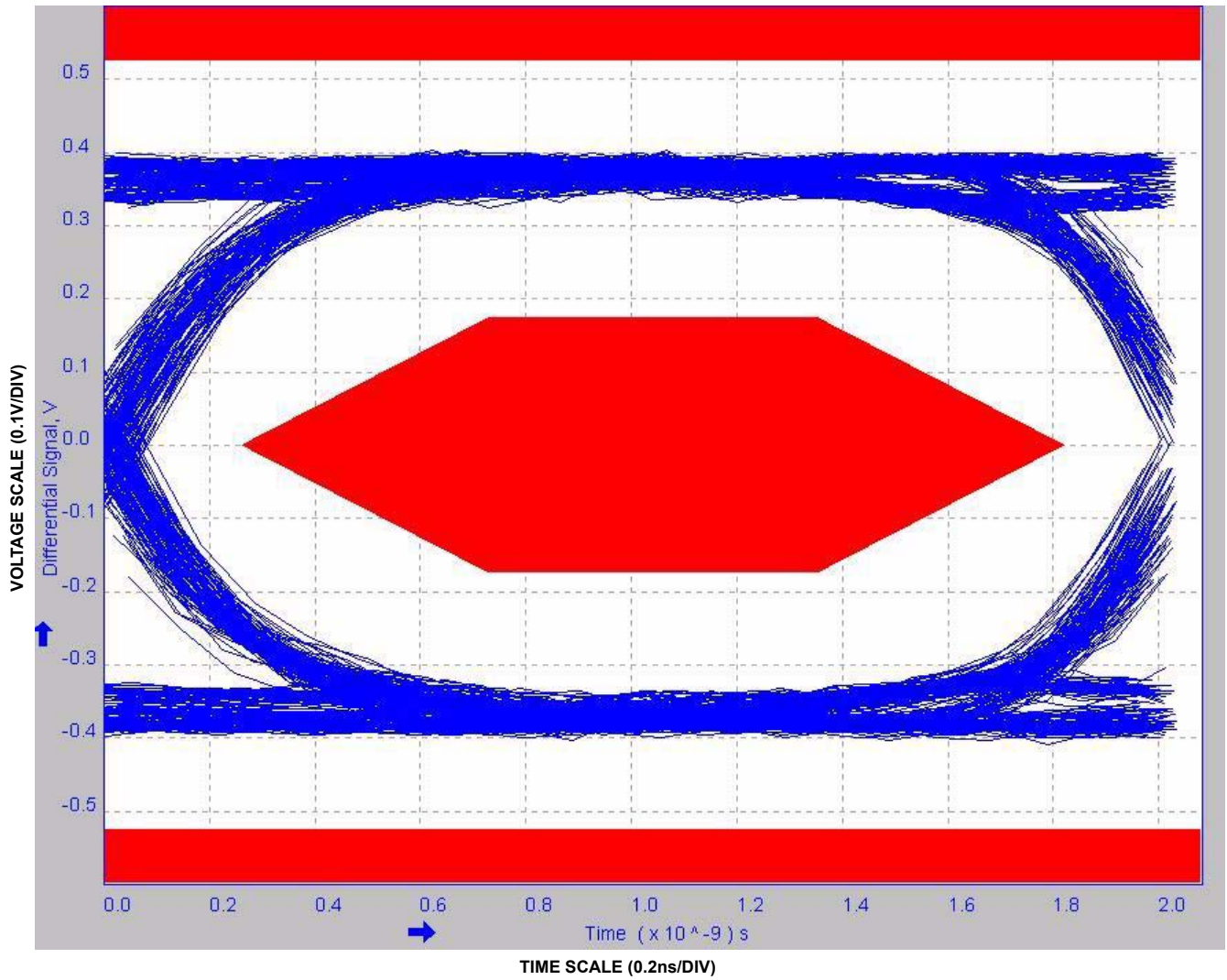

FIGURE 19. THD+N vs OUTPUT POWER

**Typical Performance Curves**  $T_A = +25^\circ\text{C}$ , Unless Otherwise Specified (Continued)



**FIGURE 20. EYE PATTERN: 480Mbps WITH USB SWITCHES IN THE SIGNAL PATH**

**Typical Performance Curves**  $T_A = +25^\circ\text{C}$ , Unless Otherwise Specified (Continued)

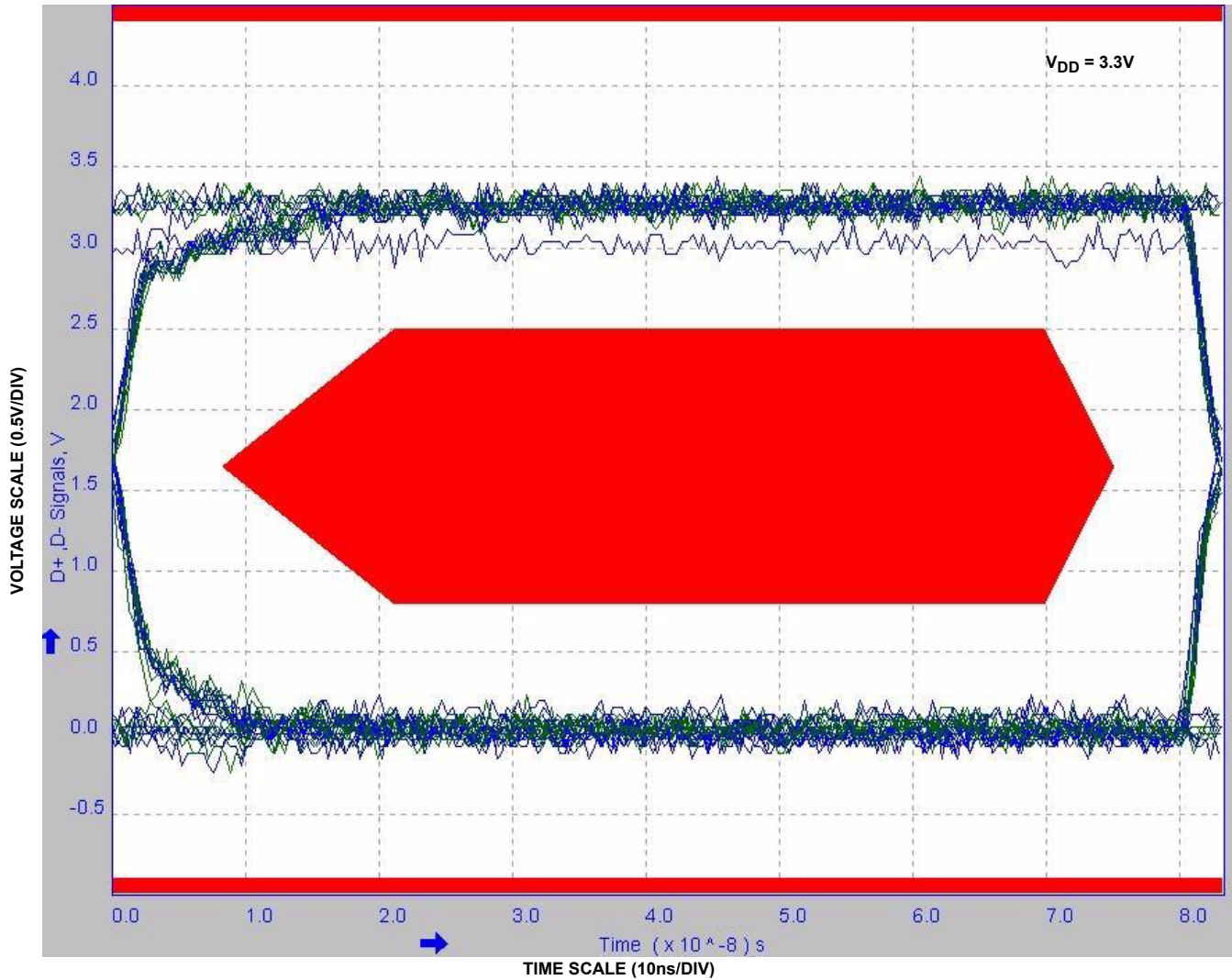

FIGURE 21. EYE PATTERN: 12Mbps USB SIGNAL WITH USB SWITCHES IN THE SIGNAL PATH

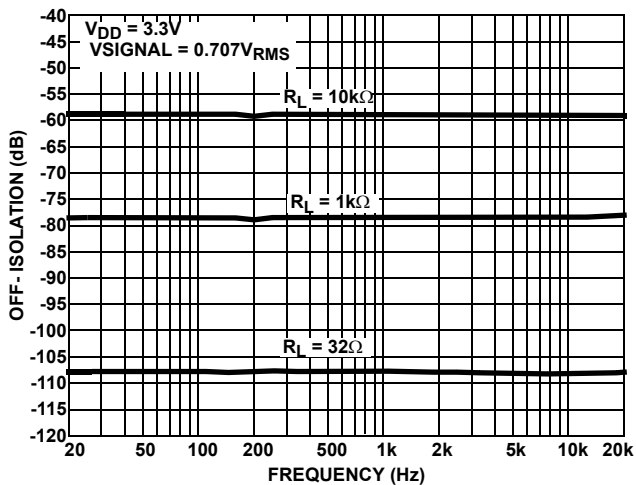

FIGURE 22. OFF-ISOLATION AUDIO SWITCHES vs LOADING

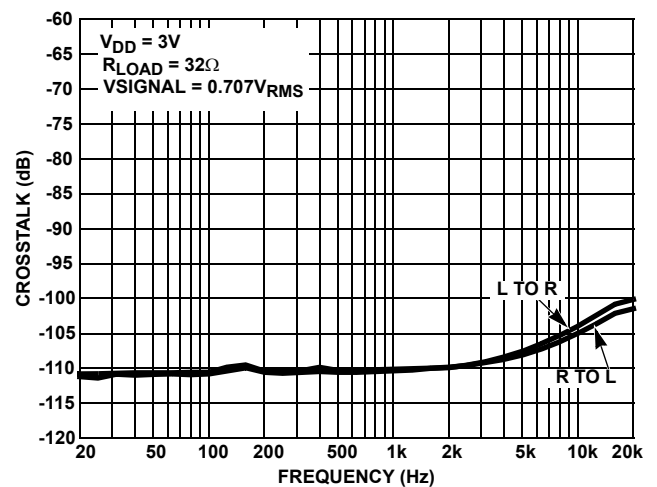

FIGURE 23. AUDIO CHANNEL-TO-CHANNEL CROSSTALK

**Typical Performance Curves**  $T_A = +25^\circ\text{C}$ , Unless Otherwise Specified (Continued)

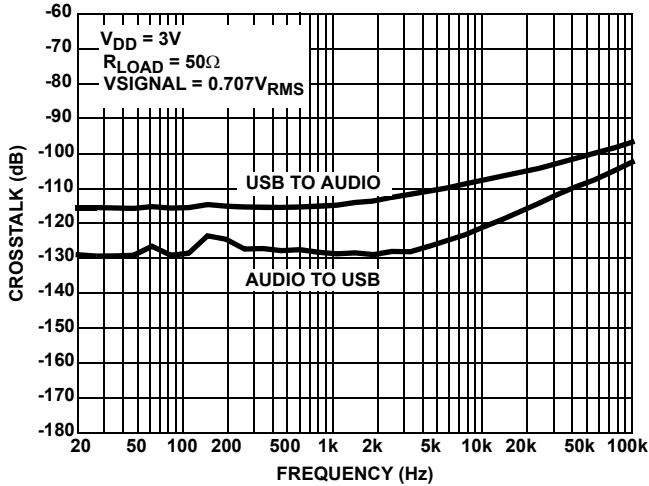

FIGURE 24. CHANNEL-TO-CHANNEL CROSSTALK

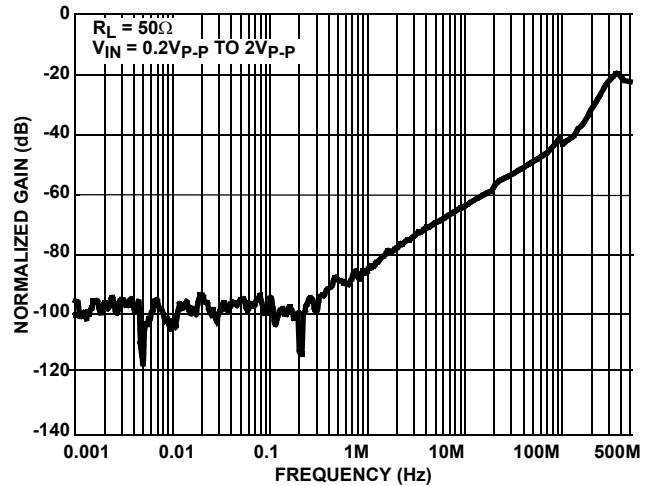

FIGURE 25. OFF-ISOLATION USB SWITCHES

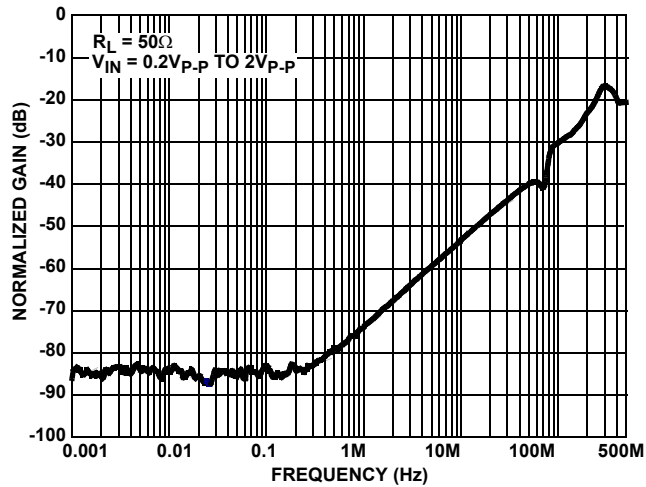

FIGURE 26. OFF-ISOLATION AUDIO SWITCHES

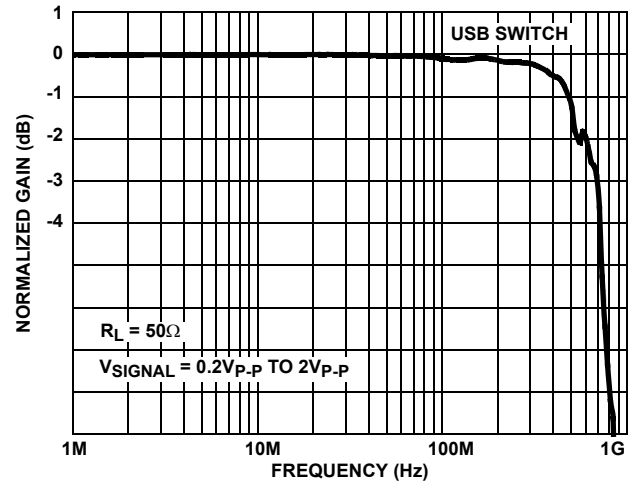

FIGURE 27. FREQUENCY RESPONSE

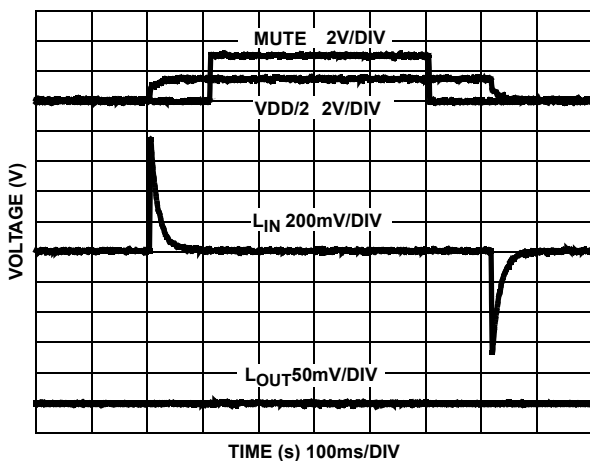

FIGURE 28. 32Ω AC-COUPLED CLICK/POP REDUCTION

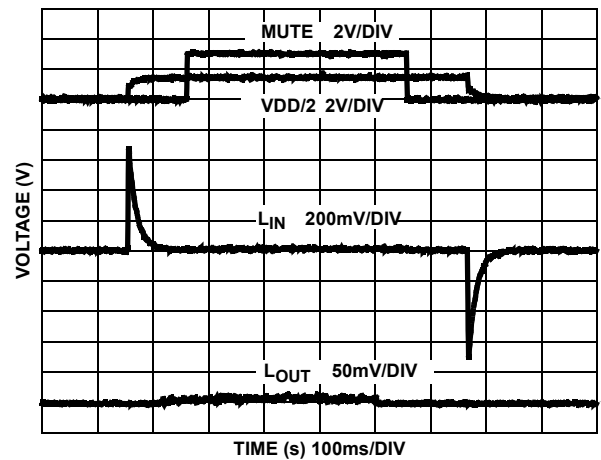
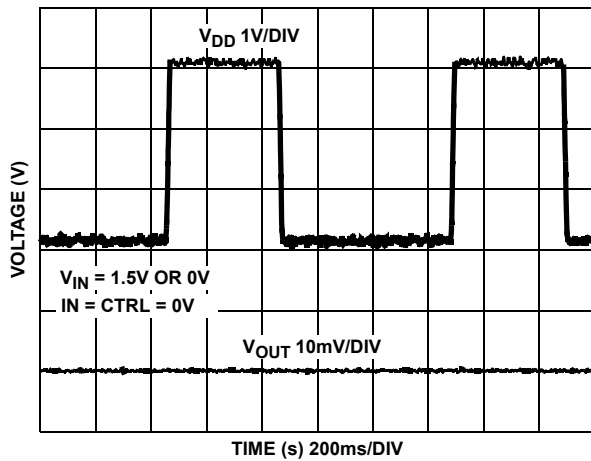

FIGURE 29. 1kΩ AC-COUPLED CLICK/POP REDUCTION

**Typical Performance Curves**  $T_A = +25^\circ\text{C}$ , Unless Otherwise Specified (Continued)

**FIGURE 30. POWER-UP/POWER-DOWN CLICK AND POP TRANSIENT**

**Die Characteristics**

**SUBSTRATE POTENTIAL (POWERED UP):**

GND

**TRANSISTOR COUNT:**

98

**PROCESS:**

Submicron CMOS

© Copyright Intersil Americas LLC 2008. All Rights Reserved.

All trademarks and registered trademarks are the property of their respective owners.

For additional products, see [www.intersil.com/en/products.html](http://www.intersil.com/en/products.html)

Intersil products are manufactured, assembled and tested utilizing ISO9001 quality systems as noted in the quality certifications found at [www.intersil.com/en/support/qualandreliability.html](http://www.intersil.com/en/support/qualandreliability.html)

*Intersil products are sold by description only. Intersil may modify the circuit design and/or specifications of products at any time without notice, provided that such modification does not, in Intersil's sole judgment, affect the form, fit or function of the product. Accordingly, the reader is cautioned to verify that datasheets are current before placing orders. Information furnished by Intersil is believed to be accurate and reliable. However, no responsibility is assumed by Intersil or its subsidiaries for its use; nor for any infringements of patents or other rights of third parties which may result from its use. No license is granted by implication or otherwise under any patent or patent rights of Intersil or its subsidiaries.*

For information regarding Intersil Corporation and its products, see [www.intersil.com](http://www.intersil.com)

**Thin Dual Flat No-Lead Plastic Package (TDFN)**

**L10.3x3A**

**10 LEAD THIN DUAL FLAT NO-LEAD PLASTIC PACKAGE**

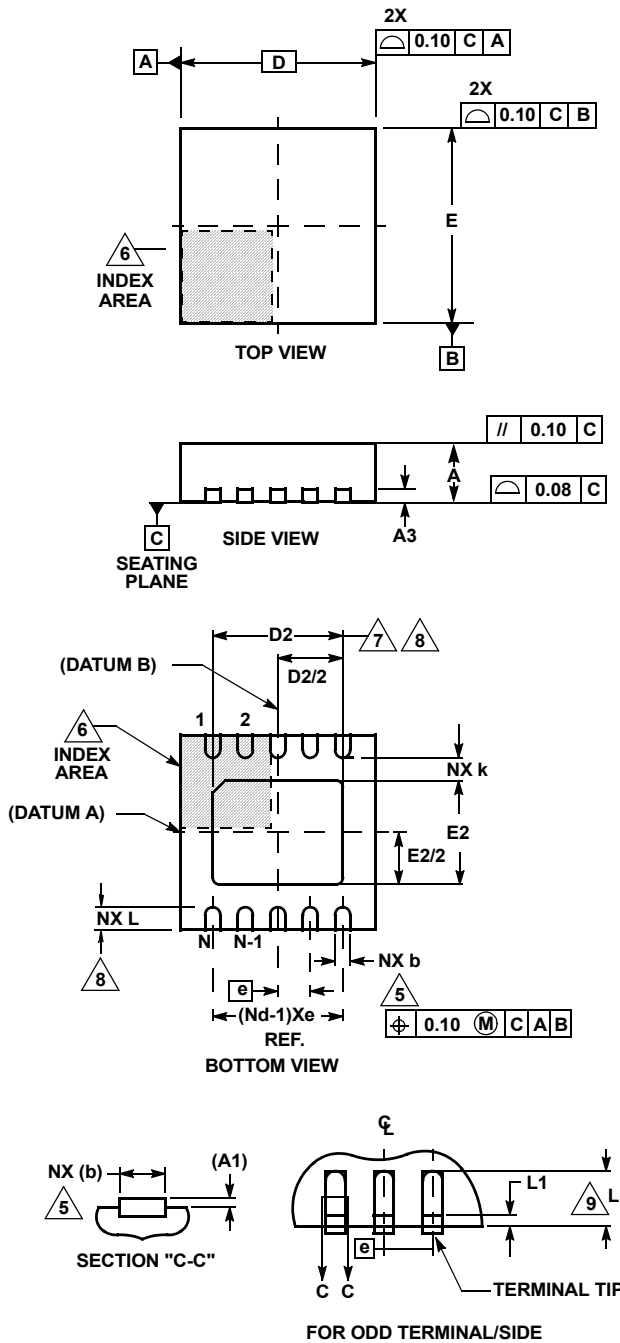

SYMBOL	MILLIMETERS			NOTES
	MIN	NOMINAL	MAX	
A	0.70	0.75	0.80	-
A1	-	-	0.05	-
A3	0.20 REF			-
b	0.20	0.25	0.30	5, 8
D	2.95	3.0	3.05	-
D2	2.25	2.30	2.35	7, 8
E	2.95	3.0	3.05	-
E2	1.45	1.50	1.55	7, 8
e	0.50 BSC			-
k	0.25	-	-	-
L	0.25	0.30	0.35	8
N	10			2
Nd	5			3

Rev. 3 3/06

**NOTES:**

1. Dimensioning and tolerancing conform to ASME Y14.5-1994.
2. N is the number of terminals.
3. Nd refers to the number of terminals on D.
4. All dimensions are in millimeters. Angles are in degrees.
5. Dimension b applies to the metallized terminal and is measured between 0.15mm and 0.30mm from the terminal tip.
6. The configuration of the pin #1 identifier is optional, but must be located within the zone indicated. The pin #1 identifier may be either a mold or mark feature.
7. Dimensions D2 and E2 are for the exposed pads which provide improved electrical and thermal performance.
8. Nominal dimensions are provided to assist with PCB Land Pattern Design efforts, see Intersil Technical Brief TB389.
9. Compliant to JEDEC MO-229-WEED-3 except for D2 dimensions.

**Ultra Thin Quad Flat No-Lead Plastic Package (UTQFN)**

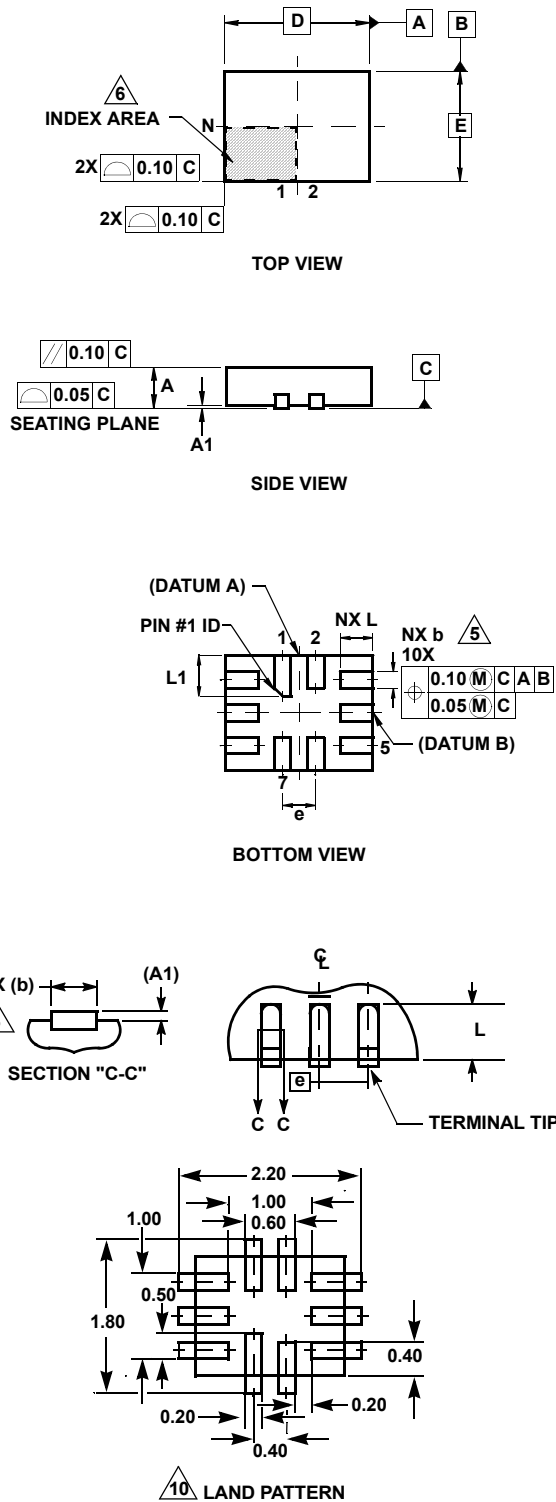

**L10.1.8x1.4A**  
**10 LEAD ULTRA THIN QUAD FLAT NO-LEAD PLASTIC PACKAGE**

SYMBOL	MILLIMETERS			NOTES
	MIN	NOMINAL	MAX	
A	0.45	0.50	0.55	-
A1	-	-	0.05	-
A3	0.127 REF			-
b	0.15	0.20	0.25	5
D	1.75	1.80	1.85	-
E	1.35	1.40	1.45	-
e	0.40 BSC			-
L	0.35	0.40	0.45	-
L1	0.45	0.50	0.55	-
N	10			2
Nd	2			3
Ne	3			3
θ	0	-	12	4

Rev. 3 6/06

**NOTES:**

1. Dimensioning and tolerancing conform to ASME Y14.5-1994.
2. N is the number of terminals.
3. Nd and Ne refer to the number of terminals on D and E side, respectively.
4. All dimensions are in millimeters. Angles are in degrees.
5. Dimension b applies to the metallized terminal and is measured between 0.15mm and 0.30mm from the terminal tip.
6. The configuration of the pin #1 identifier is optional, but must be located within the zone indicated. The pin #1 identifier may be either a mold or mark feature.
7. Maximum package warpage is 0.05mm.
8. Maximum allowable burrs is 0.076mm in all directions.
9. JEDEC Reference MO-255.
10. For additional information, to assist with the PCB Land Pattern Design effort, see Intersil Technical Brief TB389.

## Looking for pricing, stock, or lifecycle information?

Click below to explore more details on WIN SOURCE:

-  [View ISL54211IRTZ on WIN SOURCE](#)
-  [Renesas Electronics America](#) Information

## Optimize Your Supply Chain with WIN SOURCE Solutions

-  Global Sourcing Solution
-  Obsolete Management
-  Cost Control Management
-  Shortage Management
-  Alternative Solution
-  Excess Inventory Management