



**THE DATASHEET OF
NCV30161MNWTXG**



NCV30161

Constant-Current Buck Regulator for Driving High Power LEDs

The NCV30161 is a hysteretic step-down, constant-current driver for high power LEDs. Ideal for industrial and automotive applications utilizing minimal external components. The NCV30161 operates with an input voltage range from 6.3 V to 40 V. The hysteretic control gives good power supply rejection and fast response during load transients and PWM dimming to LED arrays of varying number and type. A dedicated PWM input ($\overline{\text{DIM/EN}}$) enables a wide range of pulsed dimming, and a high switching frequency allows the use of smaller external components minimizing space and cost. Protection features include resistor-programmed constant LED current, shorted LED protection, under-voltage and thermal shutdown. The NCV30161 is available in a DFN10 3 mm x 3 mm package with wettable flanks.

Features

- VIN Range 6.3 V to 40 V
- Short LED Shutdown Protection: (NCV30161 Latching)
- No Control Loop Compensation Required
- Adjustable LED Current
- Single Pin Brightness and Enable/Disable Control Using PWM
- Supports All-Ceramic Output Capacitors and Capacitor-less Outputs
- Thermal Shutdown Protection
- Capable of 100% Duty Cycle Operation
- Thermally Enhanced DFN10 with Wettable Flanks
- AEC-Q100 Qualified and PPAP Capable
- Specified from -40°C to $+125^{\circ}\text{C}$
- This is a Pb-Free Device

Typical Applications

- LED Driver
- Constant Current Source
- Automotive Lighting
- Industrial Lighting

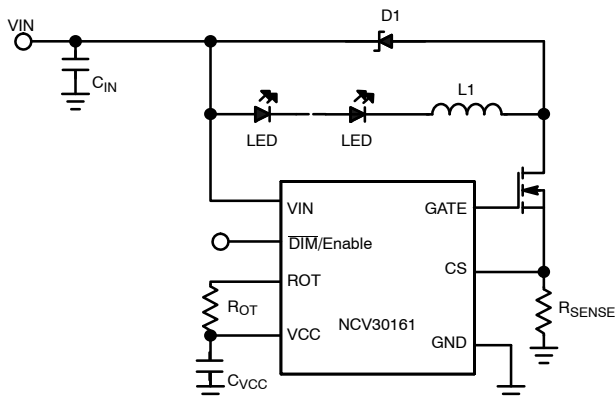

Figure 1. Typical Application Circuit



ON Semiconductor®

www.onsemi.com



DFN10
CASE 507AE

MARKING DIAGRAM

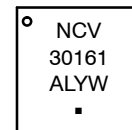

NCV30161 = Specific Device Code
 A = Assembly Location
 L = Wafer Lot
 Y = Year
 W = Work Week
 ■ = Pb-Free Package

PIN CONNECTIONS

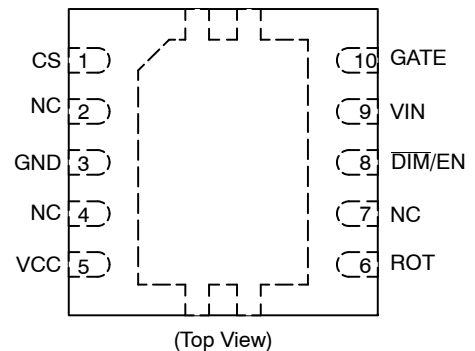

ORDERING INFORMATION

Device	Package	Shipping†
NCV30161MNWTXG	DFNW10 (Pb-Free)	3000 / Tape & Reel

†For information on tape and reel specifications, including part orientation and tape sizes, please refer to our Tape and Reel Packaging Specifications Brochure, BRD8011/D.

NCV30161

PIN FUNCTION DESCRIPTION

Pin	Pin Name	Description	Application Information
1	CS	Current Sense feedback pin	Set the current through the LED array by connecting a resistor from this pin to ground.
2, 4, 7	NC	No Connect	
3	GND	Ground Pin	Ground. Reference point for all voltages
5	VCC	Output of Internal 5 V linear regulator	The VCC pin supplies the power to the internal circuitry. The VCC is the output of a linear regulator which is powered from VIN. A 2 μ F ceramic capacitor is recommended for bypassing and should be placed as close as possible to the VCC and GND pins. Do not connect to an external load.
6	ROT	Initial Off-Time Setting Resistor	Resistor ROT from this pin to VCC sets the initial off-time range for the hysteretic controller.
8	DIM/EN	PWM Dimming Control and ENABLE	Connect a logic-level PWM signal to this pin to enable/disable the power MOSFET and LED array
9	VIN	Input Voltage Pin	Nominal operating input range is 6.3 V to 40 V. Input supply pin to the internal circuitry and the positive input to the current sense comparators. Due to high frequency noise, a 10 μ F ceramic capacitor is recommended to be placed as close as possible to VIN and power ground.
10	GATE	Driver Output	Connect to the gate of the external MOSFET.
11	FLAG		Thermal flag. There is no electrical connection to the IC. Connect to ground plane.

NCV30161

MAXIMUM RATINGS

Rating	Symbol	Min	Max	Unit
VIN to GND	VIN	-0.3	40	V
Driver Output Voltage to GND	GATE	-0.3	6.5	V
VCC to GND	VCC	-0.3	6	V
$\overline{\text{DIM}}/\text{EN}$ to GND	DIM	-0.3	6	V
CS to GND	CS	-0.3	6	V
ROT to GND	ROT	-0.3	6	V
Absolute Maximum junction temperature	$T_{J(\text{MAX})}$	150		°C
Operating Junction Temperature Range	TJ	-40	125	°C
Storage Temperature Range	T_{stg}	-55 to +125		°C
Thermal Characteristics DFN10 3x3 Plastic Package Maximum Power Dissipation @ $T_A = 25^\circ\text{C}$ (Note 1)	PD	1.46		W
Thermal Resistance Junction-to-Ambient (Note 2)	$R_{\theta\text{JA}}$	86		°C/W
Lead Temperature Soldering (10 sec): Reflow (SMD styles only) Pb-Free (Note 3)	TL	260		°C
Moisture Sensitivity Level (Note 4)	MSL	1		-

Stresses exceeding those listed in the Maximum Ratings table may damage the device. If any of these limits are exceeded, device functionality should not be assumed, damage may occur and reliability may be affected.

1. The maximum package power dissipation limit must not be exceeded.

$$P_D = \frac{T_{J(\text{max})} - T_A}{R_{\theta\text{JA}}}$$

2. When mounted on a multi-layer board with 35 mm² copper area, using 1 oz Cu.

3. 60–180 seconds minimum above 237°C.

4. Moisture Sensitivity Level (MSL): 1 per IPC/JEDEC standard: J-STD-020A.

NCV30161

ELECTRICAL CHARACTERISTICS (Unless otherwise noted: $V_{IN} = 12\text{ V}$, $T_A = -40^\circ\text{C}$ to $+125^\circ\text{C}$. Typical values at $T_A = 25^\circ\text{C}$)

Symbol	Characteristics	Min	Typ	Max	Unit
--------	-----------------	-----	-----	-----	------

SYSTEM PARAMETERS

V_{IN}	Input Supply Voltage Range	Normal Operation	8.0		40	V
		Functional (Note 5)	6.3			
I_{Q_IN}	Quiescent Current into V_{IN}	0.075	1.5	2.15	mA	
V_{CC}	Internal Regulator Output (Note 6)	4.0	5.0	5.5	V	
V_{UV+}	Under-Voltage Lock-out Threshold (V_{IN} Rising)	5.5	6.0	6.5	V	
V_{UV-}	Under-Voltage Lock-out Threshold (V_{IN} Falling)	5.2	5.6	6.3	V	

CURRENT LIMIT AND REGULATION

V_{CS_UL}	CS Regulation Upper Limit (CS Increasing, FET Turns-OFF)	25°C	213	220	226	mV
V_{CS_LL}	CS Regulation Lower Limit (CS Decreasing, FET Turns-ON)	25°C	174	180	186	mV
V_{HYS}	CS Hysteresis			40		mV
V_{OCP}	Over Current Protect Limit (Reference to CS Pin)		406	500	594	mV
F_{SW}	Switching Frequency Range (Note 7)				2400	kHz
C_{in_CS}	CS Pin Input Capacitance (Note 7)		4.0	5.0	6.0	pF
$t_{BLANKING}$	CS Blanking Timer (Note 7)		50	73	105	ns

DIM INPUT

$V_{PWMH/L}$	PWM (DIM/EN) high level input voltage	1.36				V
V_{PWML}	PWM (DIM/EN) low level input voltage			0.45		V
R_{DIM_PU}	DIM/EN Pull-up Resistor			100		k Ω
f_{pwm}	PWM (DIM/EN) dimming frequency range				20	kHz
d_{max}	Maximum Duty Cycle			100		%

MOSFET DRIVER

R_{GATE_Source}	Sourcing Current	3.0	9.0	12		Ω
R_{GATE_Sink}	Sinking Current	0.2	0.4	0.9		Ω

THERMAL SHUTDOWN

T_{SD}	Thermal Shutdown (Note 7)	160	165	180		$^\circ\text{C}$
T_{Hyst}	Thermal Hysteresis (Note 7)	30	40	60		$^\circ\text{C}$

OFF TIMER

t_{OFF_MIN}	Minimum Off-time	110	137	170		ns
----------------	------------------	-----	-----	-----	--	----

- The functional range of V_{IN} is the voltage range over which the device will function. Output current and internal parameters may deviate from normal values for V_{IN} and V_{CC} voltages between 6.3 V and 8 V, depending on load conditions
- V_{CC} should not be driven from a voltage higher than V_{IN} or in the absence of a voltage at V_{IN} .
- Guaranteed by design.

NCV30161

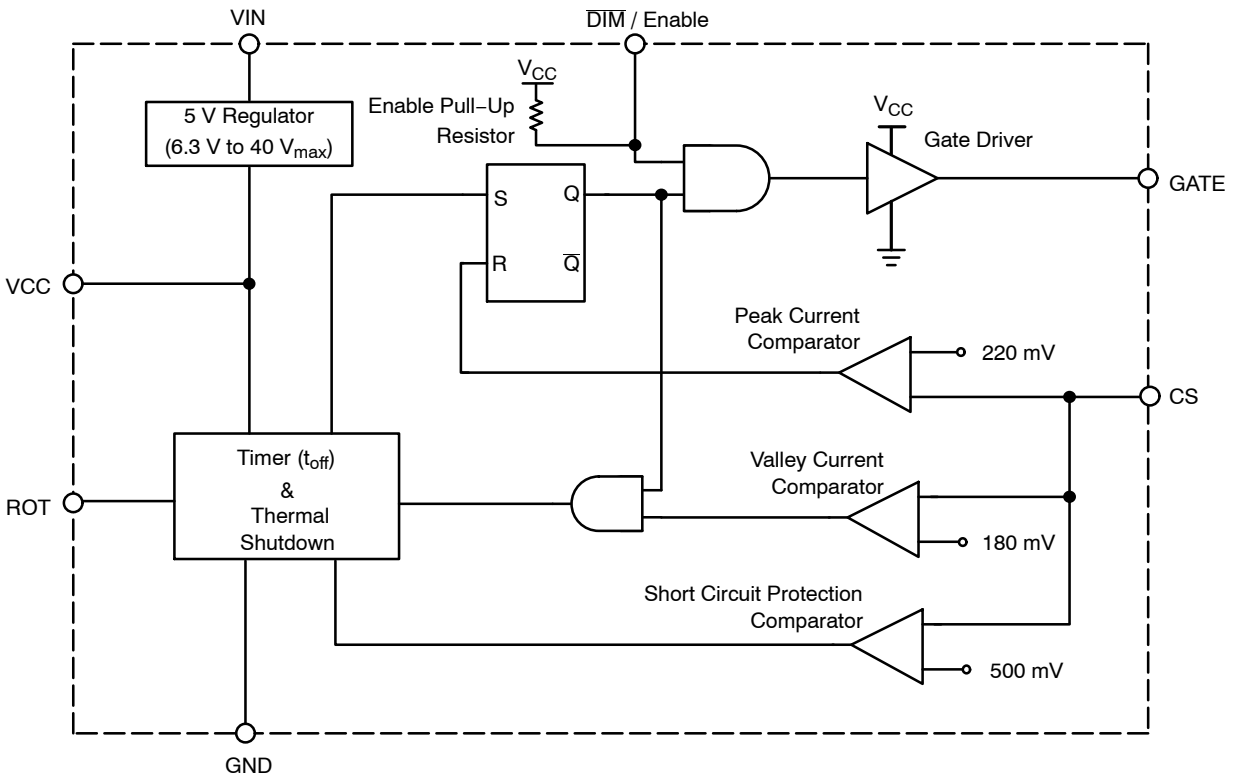

Figure 2. Simplified Block Diagram

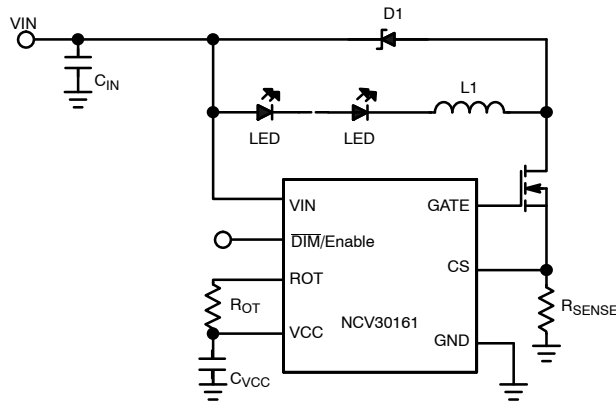

Figure 3. Typical Application Circuit To Drive Multiple LEDs (Buck)

Theory of Operation

This switching power supply is comprised of an inverted buck regulator controlled by a current mode, hysteretic control circuit. The buck regulator operates exactly like a conventional buck regulator except the power device placement has been inverted to allow for a low side power FET. Referring to Figure 1, when the FET is conducting, current flows from the input, through the inductor, the LED and the FET to ground.

When the FET shuts off, current continues to flow through the inductor and LED, but is diverted through the diode (D1). This operation keeps the current in the LED continuous with a continuous current ramp.

The control circuit controls the current hysteretically. Figure 2 illustrates the operation of this circuit. The CS comparator thresholds are set to provide a 10% current ripple. The peak current comparator threshold of 220 mV sets I_{peak} at 10% above the average current while the valley current comparator threshold of 180 mV sets I_{valley} at 10% below the average current.

When the FET is conducting, the current in the inductor ramps up. This current is sensed by the sense resistor that is connected from CS to ground. When the voltage on the CS pin reaches 220 mV, the peak current comparator turns off the power FET. A conventional hysteretic controller would monitor the load current and turn the switch back on when the CS pin reaches 180 mV. But in this topology the current information is not available to the control circuit when the FET is off. To set the proper FET off time, the CS voltage is sensed when the FET is turned back on and a correction signal is sent to the off time circuit to adjust the off time as necessary. When the FET is turned on, there can be a lot of ringing on the CS pin that would make the voltage on the CS pin be an unreliable measure of the current through the FET. An 85 ns blanking timer is started when the GATE voltage starts to go high, to allow this ringing to settle down. At the end of this blanking timer, CS voltage is sensed to determine the valley current.

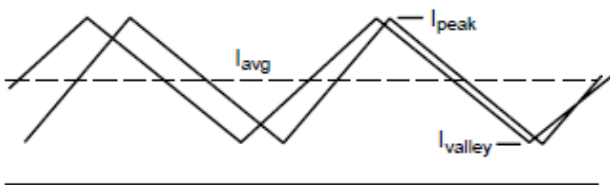

Figure 4. Typical Current Waveforms

The current wave shape is triangular, and the peak and valley currents are controlled. The average value for a triangular wave shape is halfway between the peak and valley, so even with changes in duty cycle due to input voltage variations or load changes, the average current will remain constant.

Over Current Protection & TSD Features

In the event there is a short-circuit across the LEDs, a large amount of current could potentially flow through the

circuit during startup. To protect against this, the NCV30161 comes with a short circuit protection feature. If the voltage on the CS pin is detected to be greater than the over current protection limit, the NCV30161 will turn off the FET, and prevent the FET from turning on again until power is recycled to the NCV30161.

The NCV30161 implements a TSD feature that protects the part when the junction temperature exceeds 165 degrees. There may be TSD events where the NCV30161 will turn the FET off until power is recycled then Soft start is initiated and regulation reestablished.

Undervoltage Lockout

When VIN rises above the UVLO threshold voltage, switching operation of the FET will begin. However, until the VIN voltage reaches 8 V, the VCC regulator may not provide the expected gate drive voltage to the FET. This could result in the $R_{DS(on)}$ of the FET being higher than expected or there not being enough gate drive capability to operate at the maximum rated switching frequency. For optimal performance, it is recommended to operate the part at a VIN voltage of 8 V or greater.

Setting The Output Current

The average output current is determined as being the middle of the peak and valley of the output current, set by the CS comparator thresholds. The nominal average output current will be the current value equivalent to 200 mV at the CS pin. The proper R_{SENSE} value for a desired average output current can be calculated by:

$$R_{SENSE} = \frac{200 \text{ mV}}{I_{LED}}$$

PWM Dimming

For a given R_{SENSE} value, the average output current, and therefore the brightness of the LED, can be set to a lower value through the DIM/EN pin. When the DIM/EN pin is brought low, the internal FET will turn off and switching will remain off until the DIM/EN pin is brought back into its high state.

By applying a pulsed signal to DIM/EN, the average output current can be adjusted to the duty ratio of the pulsed signal. It is recommended to keep the frequency of the DIM/EN signal above 100 Hz to avoid any visible flickering of the LED.

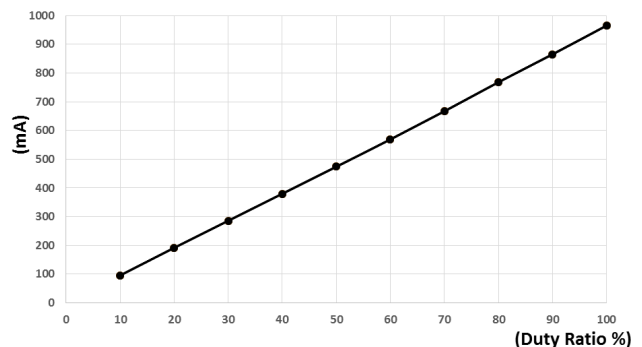

Figure 5. I_{LED} vs. F_{DIM}

Inductor Selection

The inductor that is used directly affects the switching frequency the driver operates at. The value of the inductor sets the slope at which the output current rises and falls during the switching operation. The slope of the current, in turn, determines how long it takes the current to go from the valley point of the current ripple to the peak when the FET is on and the current is rising, and how long it takes the current to go from the peak point of the current to the valley when the FET is off and the current is falling. These times can be approximated from the following equations:

$$t_{ON} = \frac{L \times \Delta I}{V_{IN} - V_{LED} - I_{OUT} \times (FET_{R_{DS}}^{(on)} + DCR_L + R_{SENSE})}$$

$$t_{OFF} = \frac{L \times \Delta I}{V_{LED} + V_{diode} + I_{OUT} \times DCR_L}$$

Where DCR_L is the dc resistance of the inductor, V_{LED} is the forward voltages of the LEDs, $FET_{R_{DS}}^{(on)}$ is the on-resistance of the power MOSFET, and V_{diode} is the forward voltage of the catch diode.

The switching frequency can then be approximated from the following:

$$f_{SW} = \frac{1}{t_{ON} + t_{OFF}}$$

Higher values of inductance lead to slower rates of rise and fall of the output current. This allows for smaller discrepancies between the expected and actual output current ripple due to propagation delays between sensing at the CS pin and the turning on and off of the power MOSFET. However, the inductor value should be chosen such that the peak output current value does not exceed the rated saturation current of the inductor.

Catch Diode Selection

The catch diode needs to be selected such that the average current through the diode does not exceed the rated average forward current of the diode. The average current through the diode can be calculated as:

$$I_{avg_diode} = I_{OUT} \times \frac{t_{OFF}}{t_{ON} + t_{OFF}}$$

It is also important to select a diode that is capable of withstanding the peak reverse voltage it will see in the application. It is recommended to select a diode with a rated reverse voltage greater than V_{IN} . It is also recommended to use a low-capacitance Schottky diode for better efficiency performance.

Selecting The Off-Time Setting Resistor

The off-time setting resistor (R_{OT}) programs the NCV30161 with the initial time duration that the MOSFET is turned off when the switching operation begins. During subsequent switching cycles, the voltage at the CS pin is sensed every time the MOSFET is turned on, and the off-time will be adjusted depending on how much of a discrepancy exists between the sensed value and the CS lower limit threshold value. Selecting an appropriate R_{OT} value allows the system to quickly achieve the intended current regulation. The R_{OT} value can be calculated using the following equation:

$$R_{OT} = t_{OFF} \times 10^{11} \Omega$$

Where t_{OFF} is the expected off time during normal switching operation, calculated in the Inductor Selection section above. The R_{OT} value can range from a minimum of 20 k Ω to a maximum of 1 M Ω resistor.

Every time the DIM/EN pin is brought from a low state to a high state, the initial off-time program is reset. The first off-time of the MOSFET after the DIM/EN is brought high will be set by the R_{OT} value. The off-time will then be adjusted in subsequent switching cycles.

Input Capacitor

A decoupling capacitor from V_{IN} to ground should be used to provide the current needed when the power MOSFET turns on. A 10 μF ceramic capacitor is recommended.

Dimming Event

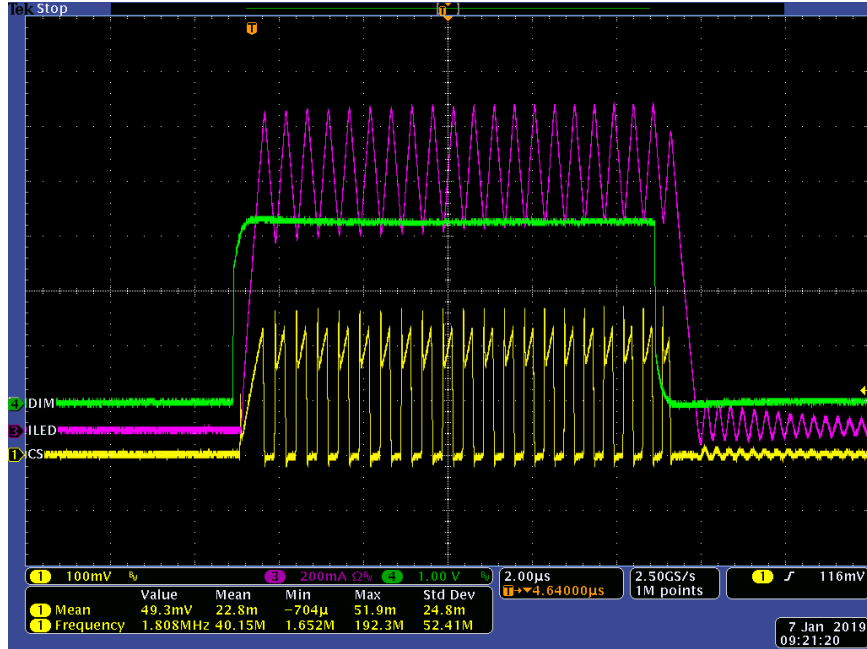

Figure 6. 12 Vin, 3.3 μH, 2 LEDs, 200 mΩ R_{sense}, 1 KHz F_{DIM}
 Purple: LED Current, Yellow: CS Pin, Green: DIM Pin

100% Duty Cycle Event at 1 A LED Current

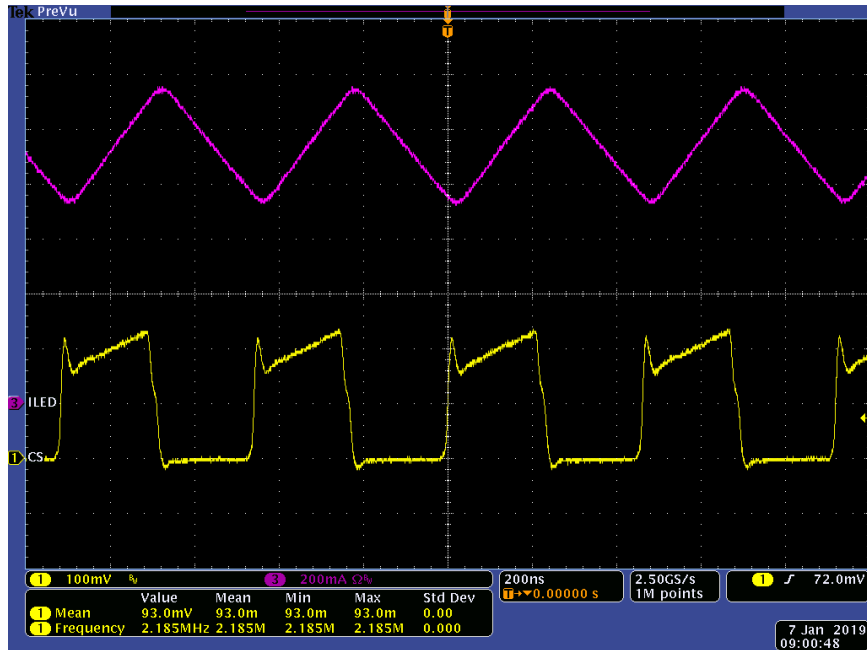

Figure 7. 12 Vin, 3.3 μH, 200 mΩ R_{sense}, 2 LEDs V_F ~ 3.5 V
 Purple: LED Current, Yellow: CS Pin

MECHANICAL CASE OUTLINE

PACKAGE DIMENSIONS

ON Semiconductor®



SCALE 2:1

DFNW10, 3x3, 0.5P
CASE 507AE
ISSUE A

DATE 15 JUN 2018

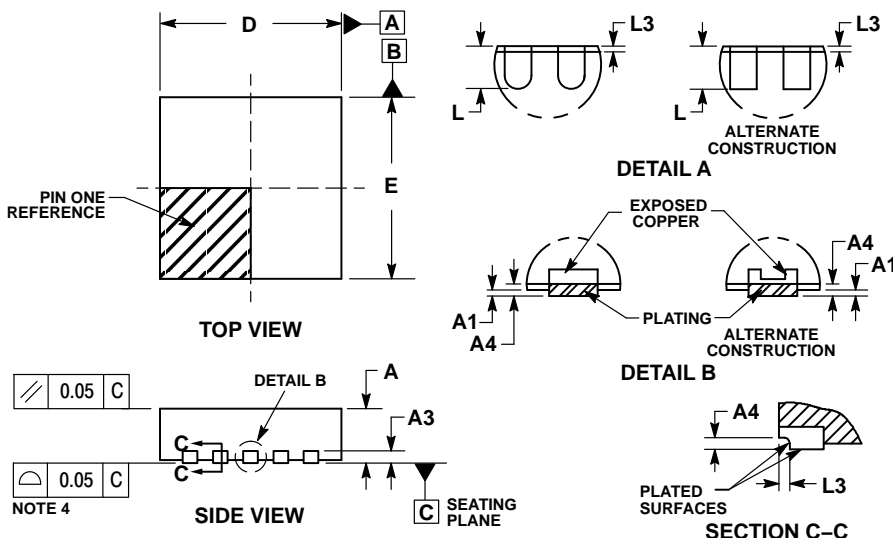

- NOTES:
- DIMENSIONING AND TOLERANCING PER ASME Y14.5M, 1994.
 - CONTROLLING DIMENSION: MILLIMETERS.
 - DIMENSION b APPLIES TO PLATED TERMINAL AND IS MEASURED BETWEEN 0.15 AND 0.30mm FROM THE TERMINAL TIP.
 - COPLANARITY APPLIES TO THE EXPOSED PAD AS WELL AS THE TERMINALS.
 - THIS DEVICE CONTAINS WETTABLE FLANK DESIGN FEATURE TO AID IN FILLET FORMATION ON THE LEADS DURING MOUNTING.

DIM	MILLIMETERS		
	MIN	NOM	MAX
A	0.80	0.90	1.00
A1	---	---	0.05
A3	0.20 REF		
A4	0.10	---	---
b	0.20	0.25	0.30
b2	0.25 REF		
D	2.90	3.00	3.10
D2	2.30	2.40	2.50
E	2.90	3.00	3.10
E2	1.55	1.65	1.75
e	0.50 BSC		
K	0.28 REF		
L	0.30	0.40	0.50
L3	0.05 REF		

GENERIC MARKING DIAGRAM*

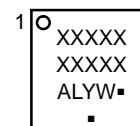

- XXXXX = Specific Device Code
- A = Assembly Location
- L = Wafer Lot
- Y = Year
- W = Work Week
- = Pb-Free Package

(Note: Microdot may be in either location)

*This information is generic. Please refer to device data sheet for actual part marking. Pb-Free indicator, "G" or microdot "▪", may or may not be present. Some products may not follow the Generic Marking.

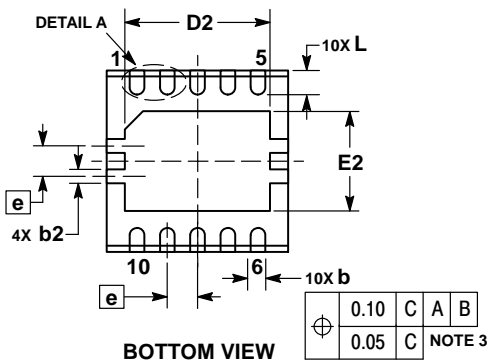

RECOMMENDED SOLDERING FOOTPRINT*

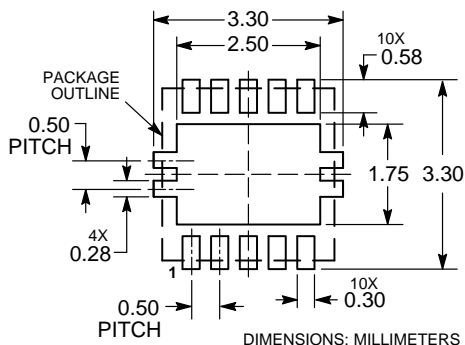

*For additional information on our Pb-Free strategy and soldering details, please download the ON Semiconductor Soldering and Mounting Techniques Reference Manual, SOLDERRM/D.

DOCUMENT NUMBER:	98AON17793G	Electronic versions are uncontrolled except when accessed directly from the Document Repository. Printed versions are uncontrolled except when stamped "CONTROLLED COPY" in red.
DESCRIPTION:	DFNW10 3x3, 0.5P	PAGE 1 OF 1

ON Semiconductor and are trademarks of Semiconductor Components Industries, LLC dba ON Semiconductor or its subsidiaries in the United States and/or other countries. ON Semiconductor reserves the right to make changes without further notice to any products herein. ON Semiconductor makes no warranty, representation or guarantee regarding the suitability of its products for any particular purpose, nor does ON Semiconductor assume any liability arising out of the application or use of any product or circuit, and specifically disclaims any and all liability, including without limitation special, consequential or incidental damages. ON Semiconductor does not convey any license under its patent rights nor the rights of others.

onsemi, **Onsemi**, and other names, marks, and brands are registered and/or common law trademarks of Semiconductor Components Industries, LLC dba "**onsemi**" or its affiliates and/or subsidiaries in the United States and/or other countries. **onsemi** owns the rights to a number of patents, trademarks, copyrights, trade secrets, and other intellectual property. A listing of **onsemi**'s product/patent coverage may be accessed at www.onsemi.com/site/pdf/Patent-Marking.pdf. **onsemi** reserves the right to make changes at any time to any products or information herein, without notice. The information herein is provided "as-is" and **onsemi** makes no warranty, representation or guarantee regarding the accuracy of the information, product features, availability, functionality, or suitability of its products for any particular purpose, nor does **onsemi** assume any liability arising out of the application or use of any product or circuit, and specifically disclaims any and all liability, including without limitation special, consequential or incidental damages. Buyer is responsible for its products and applications using **onsemi** products, including compliance with all laws, regulations and safety requirements or standards, regardless of any support or applications information provided by **onsemi**. "Typical" parameters which may be provided in **onsemi** data sheets and/or specifications can and do vary in different applications and actual performance may vary over time. All operating parameters, including "Typicals" must be validated for each customer application by customer's technical experts. **onsemi** does not convey any license under any of its intellectual property rights nor the rights of others. **onsemi** products are not designed, intended, or authorized for use as a critical component in life support systems or any FDA Class 3 medical devices or medical devices with a same or similar classification in a foreign jurisdiction or any devices intended for implantation in the human body. Should Buyer purchase or use **onsemi** products for any such unintended or unauthorized application, Buyer shall indemnify and hold **onsemi** and its officers, employees, subsidiaries, affiliates, and distributors harmless against all claims, costs, damages, and expenses, and reasonable attorney fees arising out of, directly or indirectly, any claim of personal injury or death associated with such unintended or unauthorized use, even if such claim alleges that **onsemi** was negligent regarding the design or manufacture of the part. **onsemi** is an Equal Opportunity/Affirmative Action Employer. This literature is subject to all applicable copyright laws and is not for resale in any manner.

ADDITIONAL INFORMATION

TECHNICAL PUBLICATIONS:

Technical Library: www.onsemi.com/design/resources/technical-documentation
onsemi Website: www.onsemi.com

ONLINE SUPPORT: www.onsemi.com/support

For additional information, please contact your local Sales Representative at www.onsemi.com/support/sales

Looking for pricing, stock, or lifecycle information?

Click below to explore more details on WIN SOURCE:

 [View NCV30161MNWTXG on WIN SOURCE](#)

 [ON Semiconductor](#) Information

Optimize Your Supply Chain with WIN SOURCE Solutions

-  Global Sourcing Solution
-  Obsolete Management
-  Cost Control Management
-  Shortage Management
-  Alternative Solution
-  Excess Inventory Management