



**THE DATASHEET OF
MP3362GJ-Z**



DESCRIPTION

The MP3362 is a fixed-frequency converter ideal for low-current and high-current boost applications. The low 0.2V feedback voltage offers higher efficiency in white LED driver applications.

The MP3362 regulates the output voltage up to 36V with efficiency as high as 95%. Current mode regulation and external compensation components allow the MP3362 control loop to be optimized across a wide variety of input voltages.

The MP3362 supports analog dimming and PWM dimming on the same pin. A $<2\text{kHz}$ input dimming frequency initiates PWM dimming, while an $>5\text{kHz}$ input initiates analog dimming.

Soft start, cycle-by-cycle current limiting, and input under-voltage lockout prevent overstressing or damaging sensitive external circuitry during start-up or potential overload current conditions.

The MP3362 is available in a TSOT23-8 package.

FEATURES

- 3V to 36V Input Voltage Range
- 4A Peak Current Limit
- 0.3 μA Shutdown Current
- Low 200mV Feedback Voltage
- Configurable 200kHz to 2.2MHz f_{sw}
- Internal 80m Ω , 40V Power Switch
- High Efficiency
- Analog and PWM Dimming
- Under-Voltage Lockout Protection
- Open/Short LED Protection
- Short FB Protection
- Soft-Start Operation
- Thermal Shutdown
- Available in a TSOT23-8 Package

APPLICATIONS

- Medium-Sized LCD Backlighting
- General Lighting

All MPS parts are lead-free, halogen-free, and adhere to the RoHS directive. For MPS green status, please visit the MPS website under Quality Assurance. "MPS", the MPS logo, and "Simple, Easy Solutions" are trademarks of Monolithic Power Systems, Inc. or its subsidiaries.

TYPICAL APPLICATION

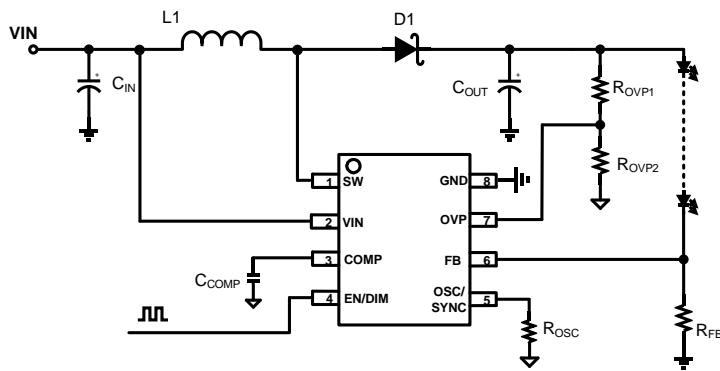

Efficiency

$f_{sw} = 1\text{MHz}$, 10 LEDs, $I_{LED} = 200\text{mA}$,
 $L = 4.7\mu\text{H}/9.5\text{m}\Omega$

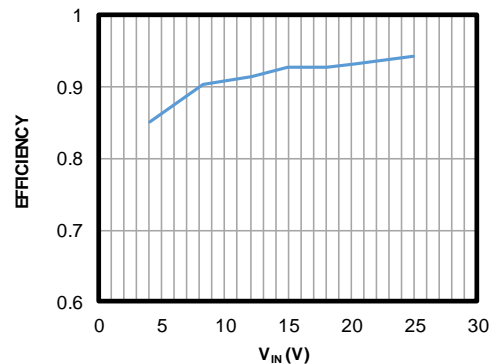

ORDERING INFORMATION

Part Number	Package	Top Marking	MSL Rating
MP3362GJ	TSOT23-8	See Below	1

* For Tape & Reel, add suffix -Z (e.g. MP3362GJ-Z).

TOP MARKING

| B J F Y

BJF: Product code of MP3362GJ
Y: Year code

PACKAGE REFERENCE

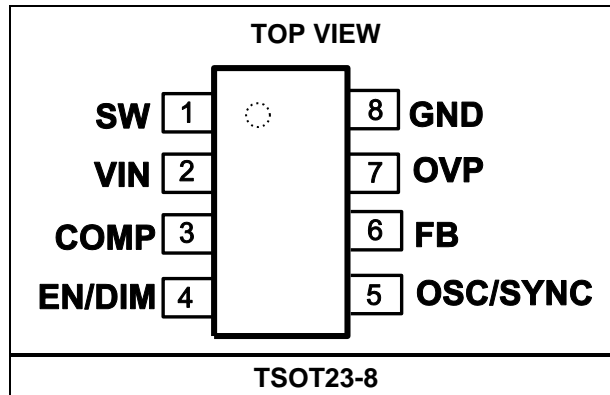

PIN FUNCTIONS

Pin #	Name	Description
1	SW	Output switch node. SW is the drain of the internal N-channel MOSFET. Connect the inductor and rectifier to SW to complete the boost converter.
2	VIN	Input supply pin. This pin can be connected to the regulator's input supply or to the output for bootstrap operation.
3	COMP	Error amplifier output compensation. Connect the COMP pin to a series RC network to compensate the regulator control loop.
4	EN/ DIM	Enable and dimming pin. Used the EN/DIM pin to enable/disable the device, or to initiate PWM dimming or analog dimming. The following conditions determine how this pin operates: 1. Keep the EN/DIM pin low for 20ms to disable the IC. 2. Apply a <2kHz PWM signal frequency to make the IC work in PWM dimming mode. 3. Apply a >5kHz PWM signal frequency to make the IC work in analog dimming mode.
5	OSC/ SYNC	Switching frequency setting and synchronization pin. Connect a resistor to this pin to program the switching frequency. Apply a pulse signal between 200kHz and 2.2MHz to synchronize the switching frequency.
6	FB	Regulation feedback input. The regulation threshold is 0.2V.
7	OVP	Open LED protection pin. OVP pin senses the output voltage to protect the IC during open LED operation.
8	GND	Ground.

ABSOLUTE MAXIMUM RATINGS ⁽¹⁾

VIN, VSW	-0.3V to +40V
All other pins	-0.3V to +5.3V
Continuous power dissipation ($T_A = 25^\circ\text{C}$) ⁽²⁾	
TSOT23-8	1.25W
Junction temperature	150°C
Lead temperature	260°C
Storage temperature.....	-65°C to +150°C

ESD Ratings

Human body model (HBM)	$\pm 2000\text{V}$
Charged device model (CDM).....	$\pm 1000\text{V}$

Recommended Operating Conditions ⁽³⁾

Supply voltage (V_{IN})	3V to 36V
Maximum LED load voltage (V_{LED}).....	36V
Operating junction temp.....	-40°C to +125°C

Thermal Resistance ⁽⁴⁾	θ_{JA}	θ_{JC}
TSOT23-8.....	100.....	55...°C/W

Notes:

- 1) Exceeding these ratings may damage the device.
- 2) The maximum allowable power dissipation is a function of the maximum junction temperature, T_J (MAX), the junction-to-ambient thermal resistance, θ_{JA} , and the ambient temperature, T_A . The maximum allowable continuous power dissipation at any ambient temperature is calculated by P_D (MAX) = $(T_J$ (MAX) - T_A) / θ_{JA} . Exceeding the maximum allowable power dissipation will produce an excessive die temperature, causing the regulator to go into thermal shutdown. Internal thermal shutdown circuitry protects the device from permanent damage.
- 3) The device is not guaranteed to function outside of its operating conditions.
- 4) Measured on JESD51-7, 4-layer PCB.

ELECTRICAL CHARACTERISTICS

$V_{IN} = 5.0V$, $T_A = 25^\circ C$, unless otherwise noted.

Parameter	Symbol	Condition	Min	Typ	Max	Units
IN shutdown supply current		$V_{EN} \leq 0V$		0.3	1.5	μA
IN operating supply current	I_{Q1}	$V_{EN} > 2V$, $V_{FB} = 0.5V$		1	1.25	mA
	I_{Q2}	With switching, 400kHz			2.5	mA
IN under-voltage lockout threshold	V_{UVLO}	V_{IN} rising	2.35	2.5	2.65	V
IN under-voltage lockout hysteresis	V_{UVLO_HYS}			100		mV
EN/DIM input low voltage	V_{EN_L}				0.4	V
EN/DIM input high voltage	V_{EN_H}		1.3			V
EN/DIM input bias current	I_{EN}	$V_{EN} = 5V$			7	μA
EN shutdown time	t_{EN}	EN/DIM low to disable IC	16	20	24	ms
SW switching frequency	f_{SW}	$R_{OSC} = 100k\Omega$	360	400	440	kHz
SW maximum duty cycle		$V_{FB} = 0.15V$, $f_{SW} = 400kHz$	90	93		$\%$
Error amplifier transconductance	G_{EA}			250		$\mu A/V$
COMP maximum output current	I_{EA}	Sourcing and sinking		30		μA
FB regulation threshold	V_{FB}	100% analog dimming	196	200	204	mV
FB input bias current	I_{FB}	$V_{FB} = 0.5V$			0.2	μA
SW on resistance	R_{ON}	$V_{IN} = 4V$		80		$m\Omega$
SW current limit	I_{LIM}	Duty = 80%	3.4	4	4.6	A
SW leakage current	I_{SW}	$V_{SW} = 40V$			0.3	μA
OVP threshold	V_{OVP}		1.10	1.18	1.26	V
OVP hysteresis	V_{OVP_HYS}			100		mV
OVP under-voltage threshold	V_{OVP_UV}			50	100	mV
Short load protection	V_{SP}	$V_{FB} > V_{SP}$, short load protection is triggered	540	600	660	mV
Latch-off current limit	I_{CL}			6.5		A
Thermal shutdown ⁽⁵⁾	T_{SD}			170		$^\circ C$
Thermal shutdown hysteresis	T_{SD_HYS}			20		$^\circ C$

Note:

5) Guaranteed by design.

TYPICAL PERFORMANCE CHARACTERISTICS

$V_{IN} = 10V$, 10 LEDs, $I_{LED} = 200mA$, $f_{SW} = 1000kHz$, $T_A = 25^{\circ}C$, unless otherwise noted.

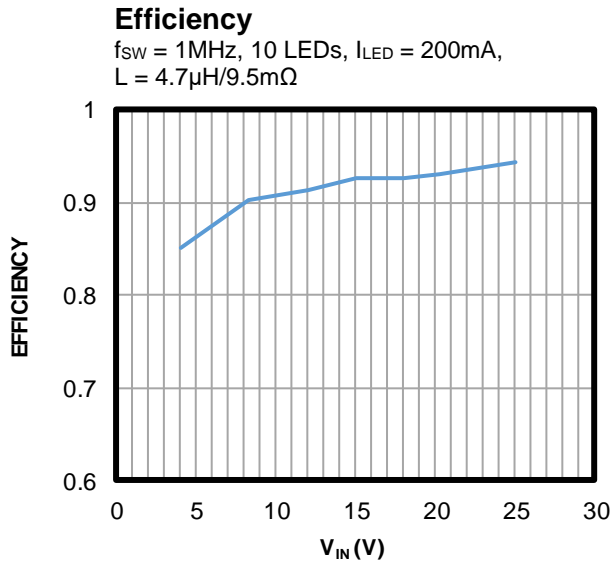

TYPICAL PERFORMANCE CHARACTERISTICS (continued)

$V_{IN} = 10V$, 10 LEDs, $I_{LED} = 200mA$, $f_{SW} = 1000kHz$, $T_A = 25^{\circ}C$, unless otherwise noted.

Steady State

$V_{IN} = 3V$, load = 3 LEDs

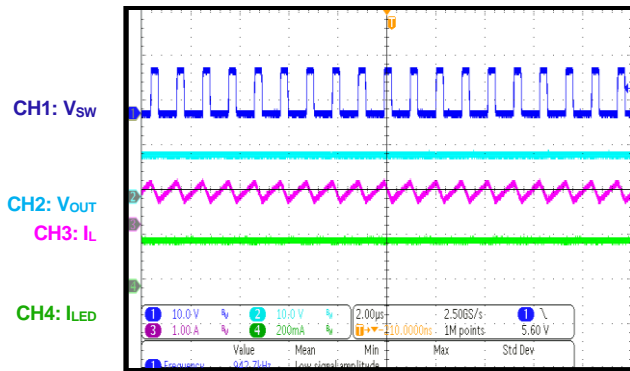

Steady State

$V_{IN} = 10V$, load = 10 LEDs

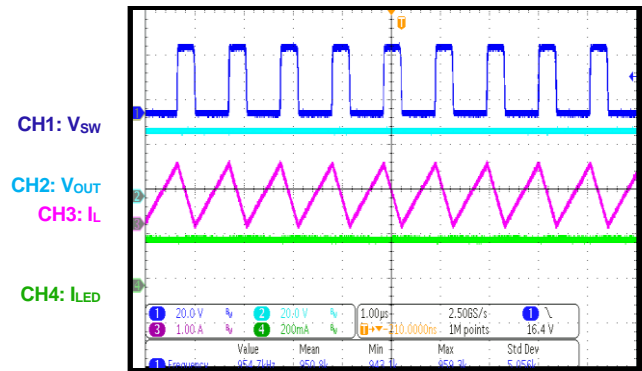

VIN Start-Up

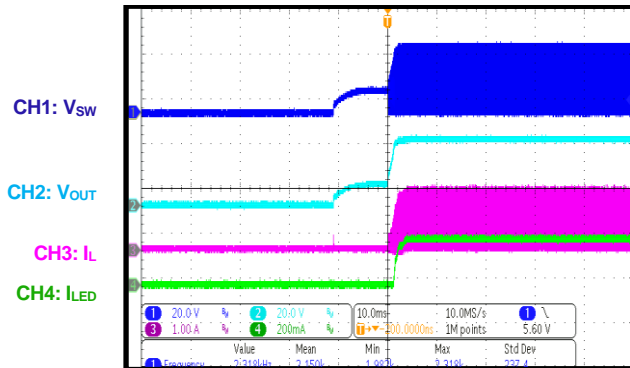

VIN Shutdown

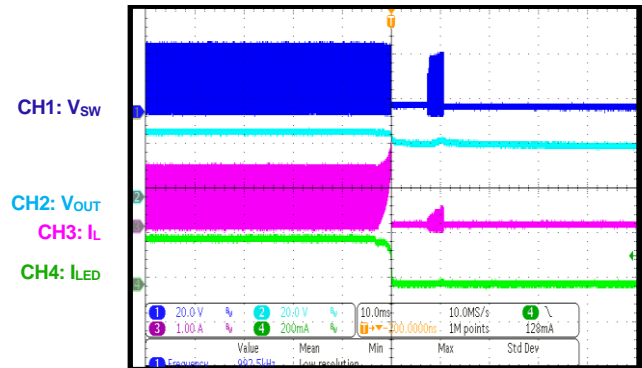

EN On

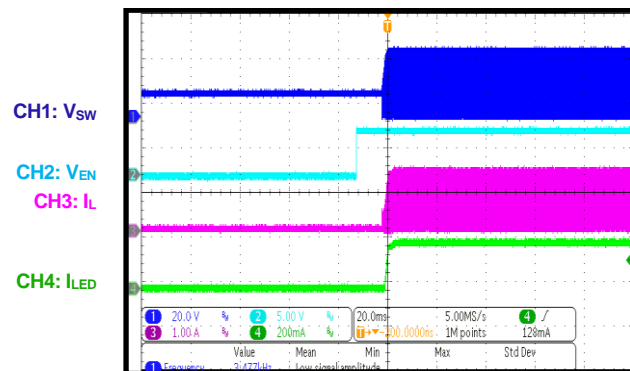

EN Off

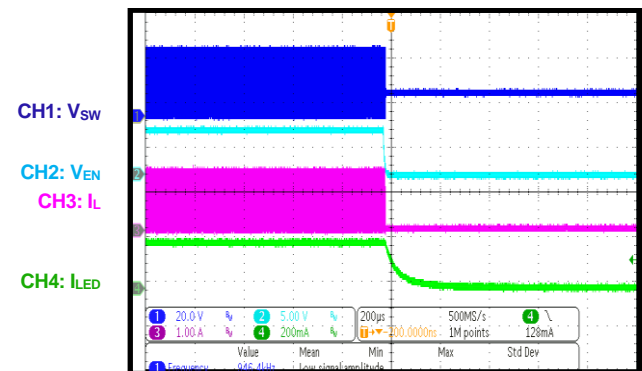

TYPICAL PERFORMANCE CHARACTERISTICS (continued)

$V_{IN} = 10V$, 10 LEDs, $I_{LED} = 200mA$, $f_{SW} = 1000kHz$, $T_A = 25^\circ C$, unless otherwise noted.

PWM Start-Up

$f_{PWM} = 10kHz$ ($D = 0.5$)

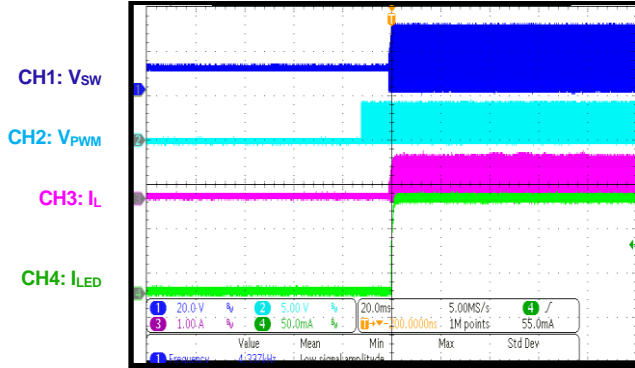

PWM Shutdown

$f_{PWM} = 10kHz$ ($D = 0.5$)

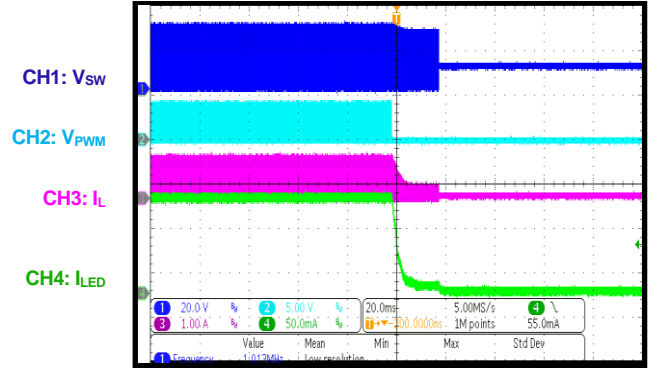

PWM Dimming

$f_{PWM} = 200Hz$ ($D = 0.5$)

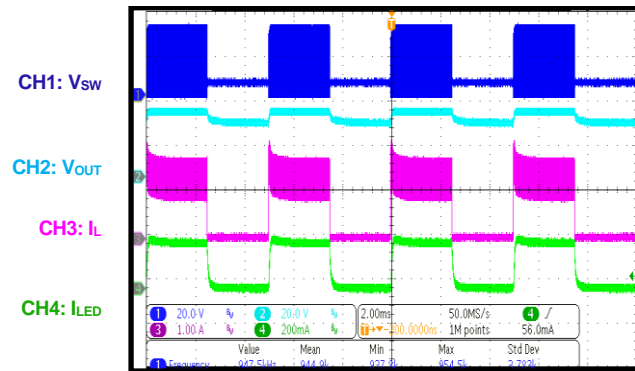

PWM Dimming

$f_{PWM} = 2kHz$ ($D = 0.5$)

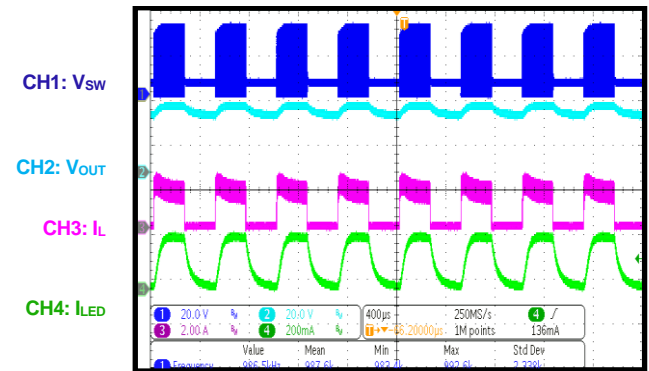

Analog Dimming

$f_{PWM} = 5kHz$ ($D = 0.5$)

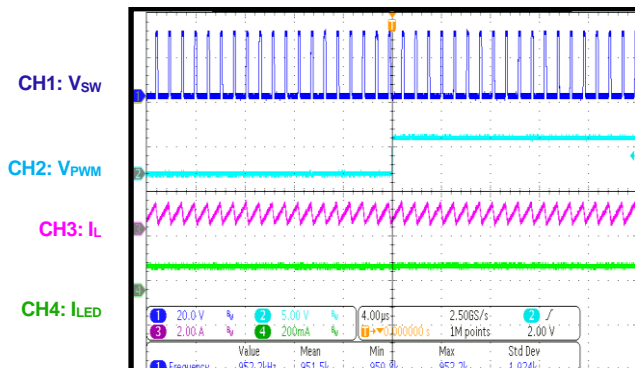

OVP during Normal Operation

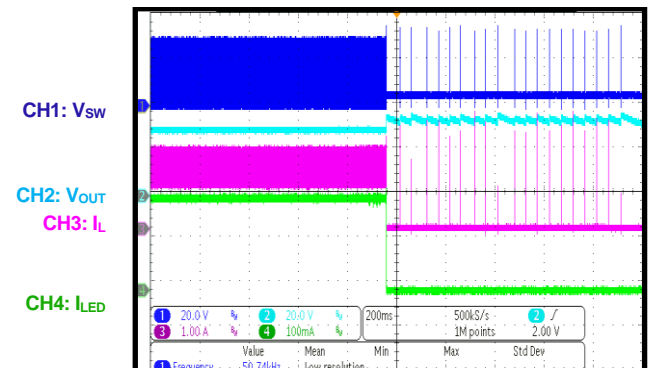

TYPICAL PERFORMANCE CHARACTERISTICS *(continued)*

$V_{IN} = 10V$, 10 LEDs, $I_{LED} = 200mA$, $f_{SW} = 1000kHz$, $T_A = 25^{\circ}C$, unless otherwise noted.

Short Inductor in Normal Operation and Recovery

Load = 5 LEDs

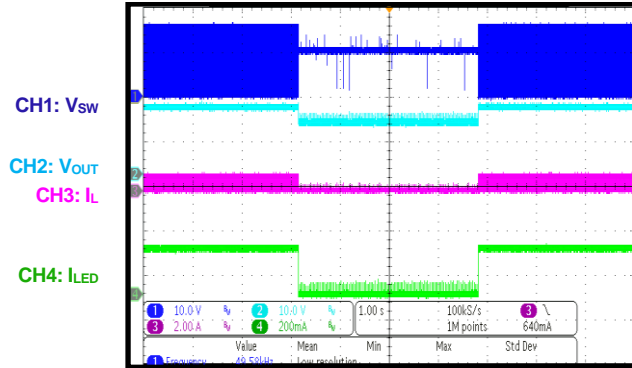

OPERATION

The MP3362 drives the internal MOSFET with current mode architecture to regulate the LED current, which is measured through an external current-sense resistor.

The MP3362 employs a special circuit to regulate the internal power supply, which covers a wide input voltage range. The switching frequency can be configured. The device integrates under-voltage lockout (UVLO), over-voltage protection (OVP), over-current protection (OCP), short LED protection, short FB to GND protection, short inductor/diode protection, and thermal protection.

Step-Up Converter

The MP3362 uses peak current control mode to regulate the output energy. At the beginning of each switching cycle, the internal clock turns on the internal N-channel MOSFET (in normal operation, the minimum turn-on time is about 50ns). A stabilizing ramp is added to the output of the current-sense amplifier to prevent subharmonic oscillations for duty cycles exceeding 50%. This result is fed into the PWM comparator. If the summed voltage reaches the output voltage of the error amplifier, the internal MOSFET turns off (for improved stability, the turn-off time should exceed 100ns).

The output voltage of the internal error amplifier is an amplified signal of the difference between the reference voltage and the FB voltage.

If the feedback voltage drops below the reference voltage, the output of the error amplifier increases. This results in more current flowing through the MOSFET, which increases the power delivered to the output. This forms a closed loop that regulates the output voltage.

If V_{OUT} is almost equal to V_{IN} under light-load conditions, the converter runs in pulse-skip mode. The MOSFET turns on for a minimum on time, and then the converter discharges the power to the output for the remaining period. The internal MOSFET remains off until the output voltage requires another boost.

Soft Start

The MP3362 implements soft start by limiting the current capability of the internal error amplifier during start-up. The COMP voltage jumps to its

clamp voltage at the beginning of start-up. The source/sink current of the internal error amplifier is limited to about $10\mu A$ until the FB voltage reaches 80% of the internal reference voltage during start-up. The maximum soft-start time is limited to 10ms to prevent the IC from always being in soft start during deep analog dimming.

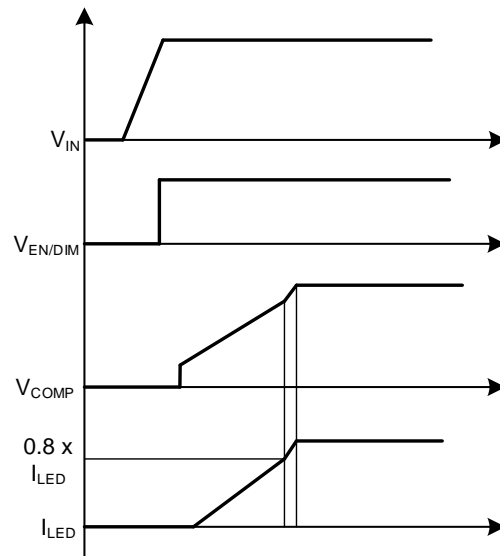

Figure 2: Soft Start

Enable (EN) and Dimming (DIM)

The EN/DIM pin can be used for different functions when different signals are applied on this pin. These functions are described below:

1. **Enable/disable:** If the EN/DIM pin is pulled high, the IC is enabled; if the EN/DIM pin is pulled low for 20ms, the IC is disabled.
2. **PWM dimming ($f_{PWM} < 2kHz$):** If the PWM signal has a frequency below 2kHz, the IC operates in PWM dimming mode. If the PWM signal is low in PWM dimming mode, the IC stops switching, and the output voltage and output current drop. If the PWM signal is high, the IC starts switching, and the output voltage and output current begin to rise. This condition prohibits soft start.
3. **Analog dimming ($f_{PWM} > 5kHz$):** If the PWM signal has a frequency exceeding 5kHz, the IC operates in analog dimming mode. The LED current can be changed by changing the PWM duty cycle.

Calculate the LED current with Equation (1):

$$I_{LED} = \frac{V_{FB}}{R_{FB}} \times \text{Duty} \quad (1)$$

Where V_{FB} is the FB voltage (about 200mV), R_{FB} is the feedback resistor, and Duty is the PWM signal duty.

Protections

The MPQ3326's protections include under-voltage lockout (UVLO), over-voltage protection (OVP), over-current protection (OCP), short LED protection, short FB-to-GND protection, short inductor/diode protection, and thermal protection.

Under-Voltage Lockout (UVLO)

The MP3362 integrates V_{IN} under-voltage lockout (UVLO) protection. The internal circuit does not work until V_{IN} reaches the UVLO rising threshold.

Over-Voltage Protection (OVP)

Over-voltage protection (OVP) is detected by sensing the voltage on the OVP pin. If the OVP pin's voltage reaches its high threshold, OVP is triggered and the IC stops switching. The IC tries to recover when the OVP pin's voltage drops to its low threshold.

Short Load Protection

Under short load conditions, a large short current is detected by the FB sense resistor. If the FB-sensed voltage exceeds 600mV for 20 switching cycles, short load protection is triggered and the IC stop switching. The IC resumes when the short disappears.

High voltage appears on the FB pin under short load conditions. Figure 3 shows additional components that are required to protect the FB pin from damage.

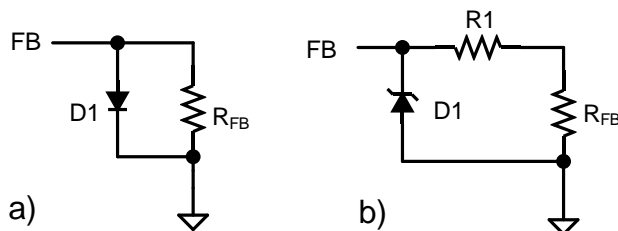

Figure 3: Short Load Protection for the FB Pin

Note that there is a short loop from the input to GND under short load conditions. Use a fuse or an external circuit to cut off the short loop.

OVP Pin Under-Voltage Protection (UVP)

If the OVP pin's voltage drops below 60mV for 10 μ s during normal operation, under-voltage protection (UVP) is triggered, and the IC stops switching. This protection is blanked during soft start.

Over-Current Protection (OCP) (Short Inductor/ Diode Protection)

The MP3362 implements cycle-by-cycle current limit protection. If there is an inductor or diode short, and the MOSFET's current exceeds the latch-off current limit value (typically 6.5A) for seven consecutive cycles, over-current protection (OCP) is triggered. The IC stop switching and resumes when the short disappears.

Short FB to GND Protection

If the FB voltage drops below 50mV and the COMP saturation lasts for 20ms, the IC stops switching. The IC resumes normal operation when the short disappears.

Thermal Protection

Thermal shutdown prevents the MP3362 from operating at exceedingly high temperatures. If the die temperature exceeds the upper threshold ($T_{SD} = 170^{\circ}\text{C}$), COMP is pulled low. The IC resumes normal operation once the die temperature drops below its lower threshold. The hysteresis is about 20°C .

APPLICATION INFORMATION

LED Current Setting

The LED current is set by the feedback resistor (R_{FB}). R_{FB} can be calculated with Equation (2):

$$R_{FB} = \frac{200mV}{I_{LED}} \quad (2)$$

Switching Frequency Setting

The switching frequency (f_{SW}) is set by an external resistor (R_{OSC}) at the OSC/SYNC pin. f_{SW} can be estimated with Equation (3):

$$f_{SW} \text{ (kHz)} = \frac{40000}{R_{OSC} \text{ (k}\Omega\text{)}} \quad (3)$$

A PWM signal (200kHz to 2.2MHz) on the OSC/SYNC pin can also synchronize f_{SW} .

Selecting the Inductor

The minimum inductance to make the circuit work in continuous conduction mode (CCM) can be calculated with Equation (4):

$$L = \frac{V_{IN} \times (V_O - V_{IN})}{V_O \times \Delta I_L \times f_{SW}} \quad (4)$$

Where ΔI_L is the peak-to-peak current of the inductor.

If the inductance is below this minimum value, the circuit works in discontinuous conduction mode (DCM).

Design ΔI_L to be between 30% and 60% of the average inductor current, estimated with Equation (5):

$$I_{L_AVG} = \frac{V_O \times I_{LED}}{V_{IN}} \quad (5)$$

Ensure that the saturated inductor current exceeds the inductor peak current, estimated with Equation (6):

$$I_{L_PK} = I_{L_AVG} + \frac{1}{2} \Delta I_L \quad (6)$$

Over-Voltage Protection (OVP) Setting

Set the over-voltage-protection (OVP) voltage threshold above 10% to 20% of the output voltage. The OVP voltage can be set with a voltage divider (see the Typical Application Circuit section on page 15). The threshold can be calculated with Equation (7):

$$V_{OVP}(V) = \frac{R_{OVP1} + R_{OVP2}}{R_{OVP2}} \times 1.2(V) \quad (7)$$

Selecting the Diode

Choose a diode with voltage rating greater than the OVP point, and leave a 20% margin. The current rating should be approximately two to three times greater than the LED current.

Selecting the Input Capacitor

The input capacitor reduces the surge current drawn from the input supply and the switching noise from the device. Ceramic capacitors with X7R dielectrics are recommended due to their low ESR and small temperature coefficients.

Select a capacitor that limits the input voltage ripple (ΔV_{IN}) below 5% to 10% of its DC value. The capacitance can be calculated with Equation (8):

$$C_{IN} \geq \frac{\Delta I_L}{8 \times \Delta V_{IN} \times f_{SW}} \quad (8)$$

Selecting the Output Capacitor

Select an output capacitor that limits the output voltage ripple (ΔV_O) below 1% to 5% of its DC value, and ensures feedback loop stability. The capacitance can be estimated with Equation (9):

$$C_{OUT} \geq \frac{I_{LED} \times (V_O - V_{IN})}{\Delta V_O \times f_{SW} \times V_O} \quad (9)$$

TYPICAL APPLICATION CIRCUITS

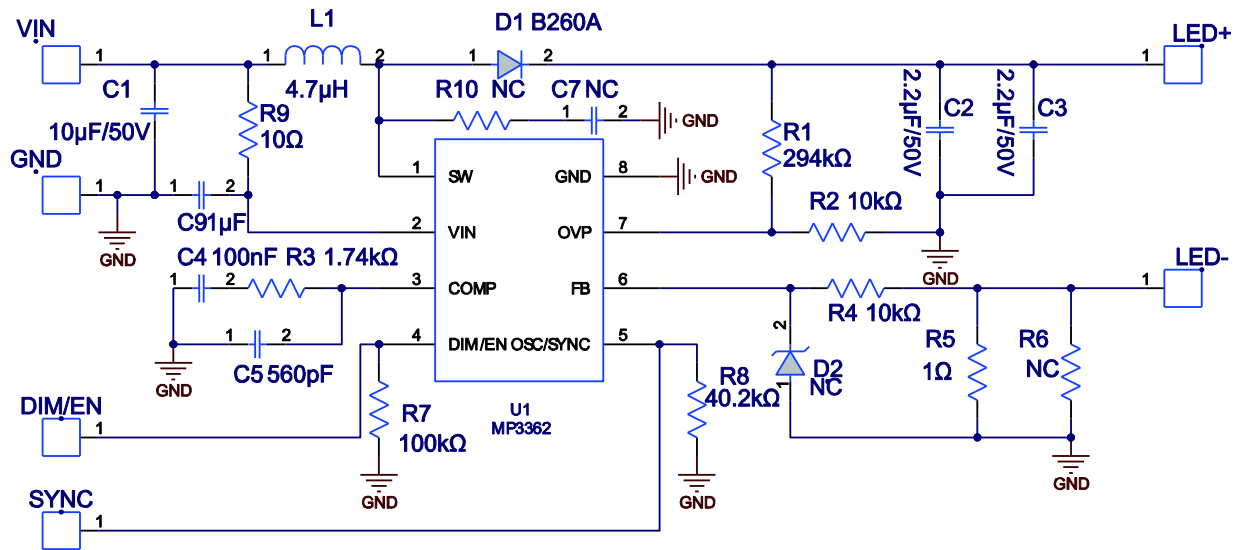

PACKAGE INFORMATION

TSOT23-8

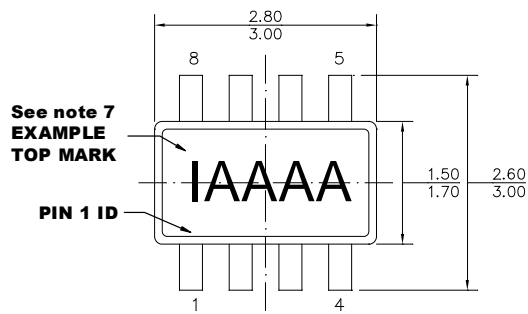

TOP VIEW

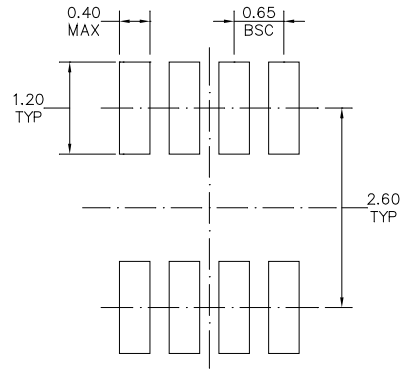

RECOMMENDED LAND PATTERN

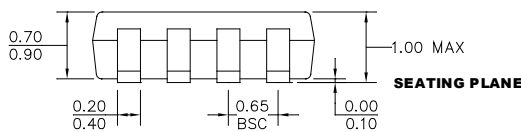

FRONT VIEW

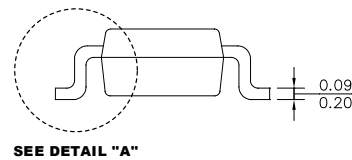

SIDE VIEW

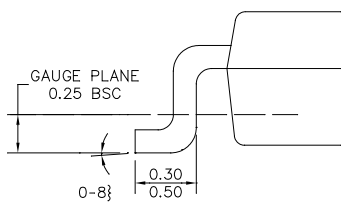

DETAIL "A"

NOTE:

- 1) ALL DIMENSIONS ARE IN MILLIMETERS.
- 2) PACKAGE LENGTH DOES NOT INCLUDE MOLD FLASH, PROTRUSION, OR GATE BURR.
- 3) PACKAGE WIDTH DOES NOT INCLUDE INTERLEAD FLASH OR PROTRUSION.
- 4) LEAD COPLANARITY (BOTTOM OF LEADS AFTER FORMING) SHALL BE 0.10 MILLIMETERS MAX.
- 5) JEDEC REFERENCE IS MO-193, VARIATION BA.
- 6) DRAWING IS NOT TO SCALE.
- 7) PIN 1 IS LOWER LEFT PIN WHEN READING TOP MARK FROM LEFT TO RIGHT, (SEE EXAMPLE TOP MARK)

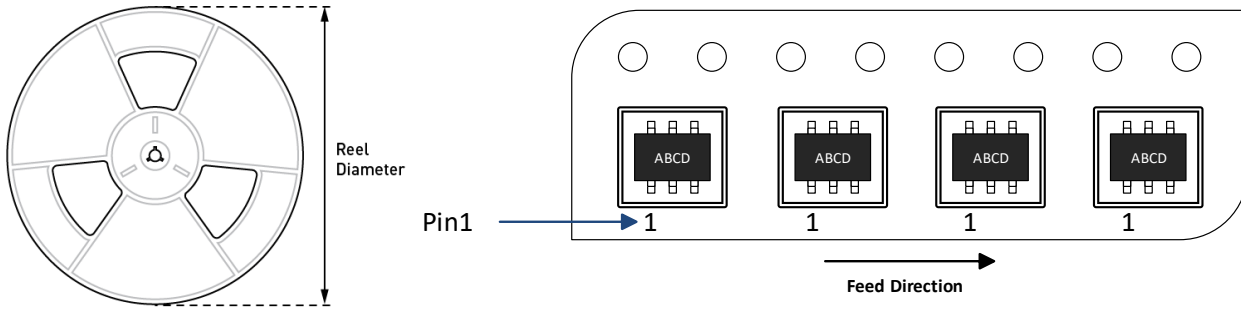
CARRIER INFORMATION

Part Number	Package Description	Quantity/ Reel	Quantity/ Tube	Quantity/ Tray	Reel Diameter	Carrier Tape Width	Carrier Tape Pitch
MP3362GJ-Z	TSOT23-8	3000	N/A	N/A	7in	8mm	4mm

REVISION HISTORY

Revision #	Revision Date	Description	Pages Updated
1.0	7/31/2020	Initial Release	-
1.1	2/22/2023	Updated “-Z” to “-Z”	2
		Updated the Selecting the Inductor section; removed the Compensation Network Setting section	13

Notice: The information in this document is subject to change without notice. Please contact MPS for current specifications. Users should warrant and guarantee that third-party Intellectual Property rights are not infringed upon when integrating MPS products into any application. MPS will not assume any legal responsibility for any said applications.

Looking for pricing, stock, or lifecycle information?

Click below to explore more details on WIN SOURCE:

- ⊖ [View MP3362GJ-Z on WIN SOURCE](#)
- ⊖ [Monolithic Power Systems Inc. Information](#)

Optimize Your Supply Chain with WIN SOURCE Solutions

- ✓ Global Sourcing Solution
- ✓ Obsolete Management
- ✓ Cost Control Management
- ✓ Shortage Management
- ✓ Alternative Solution
- ✓ Excess Inventory Management