



# Single intelligent high-current self-protected high-side switch (2.0 mOhm)

The 33982 is a self-protected silicon 2.0 mOhm high-side switch used to replace electromechanical relays, fuses, and discrete devices in power management applications. The 33982 is designed for harsh environments and includes self-recovery features. The device is suitable for loads with high inrush current, as well as motors and all types of resistive and inductive loads.

Programming, control, and diagnostics are implemented via the serial peripheral interface (SPI). A dedicated parallel input is available for alternate and pulse-width modulation (PWM) control of the output. SPI-programmable fault trip thresholds allow the device to be adjusted for optimal performance in the application.

## Features

- Single 2.0 mΩ max high-side switch with parallel input or SPI control
- 6.0 V to 27 V operating voltage with standby currents < 5.0 μA
- Output current monitoring with two SPI-selectable current ratios
- SPI control of overcurrent limit, overcurrent fault blanking time, output OFF open load detection, output ON/OFF control, watchdog timeout, slew rates, and fault status reporting
- SPI status reporting of overcurrent, open and shorted loads, overtemperature shutdown, undervoltage and overvoltage shutdown, Fail-safe pin status, and program status
- Enhanced -16 V reverse polarity  $V_{PWR}$  protection

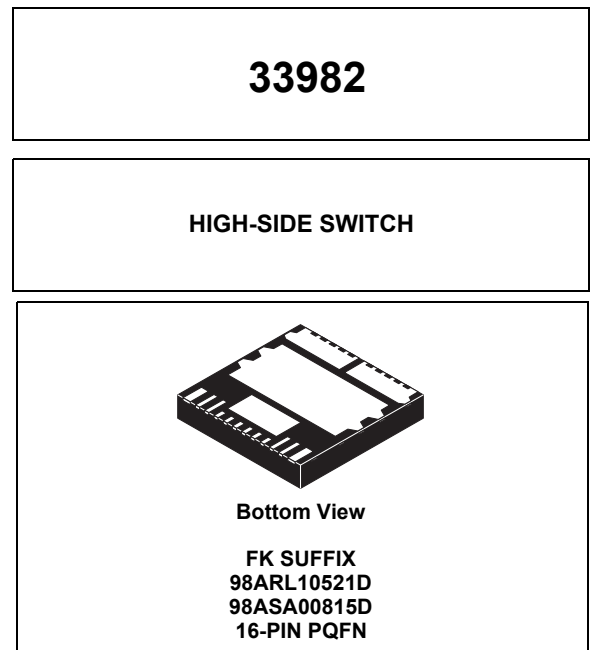

## Applications

- DC motor or solenoid
- Resistive and inductive loads
- Low-voltage lighting

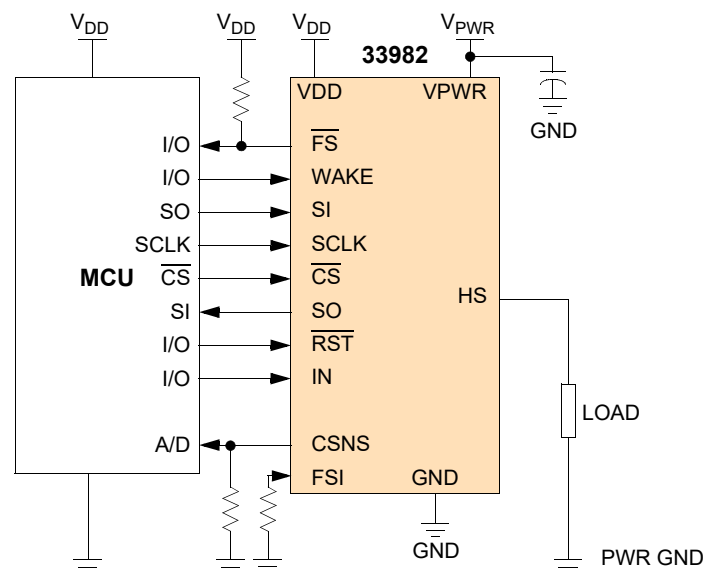

Figure 1. 33982 simplified application diagram

## Orderable parts

**Table 1. Orderable part variations <sup>(1)</sup>**

Part Number	Temperature (T <sub>A</sub> )	Package	Output Clamp Energy	Reference Location	OD3 bit for X111 address	Reference Location
MC33982CHFK	-40 °C to 125 °C	16 PQFN	1.0J	<a href="#">Table 3</a>	1	<a href="#">Table 16</a>
MC33982EHFK	-40 °C to 125 °C	16 PQFN	0.6J	<a href="#">Table 3</a>	1	<a href="#">Table 16</a>

**Notes**

1. To order parts in Tape & Reel, add the R2 suffix to the part number.

## Internal block diagram

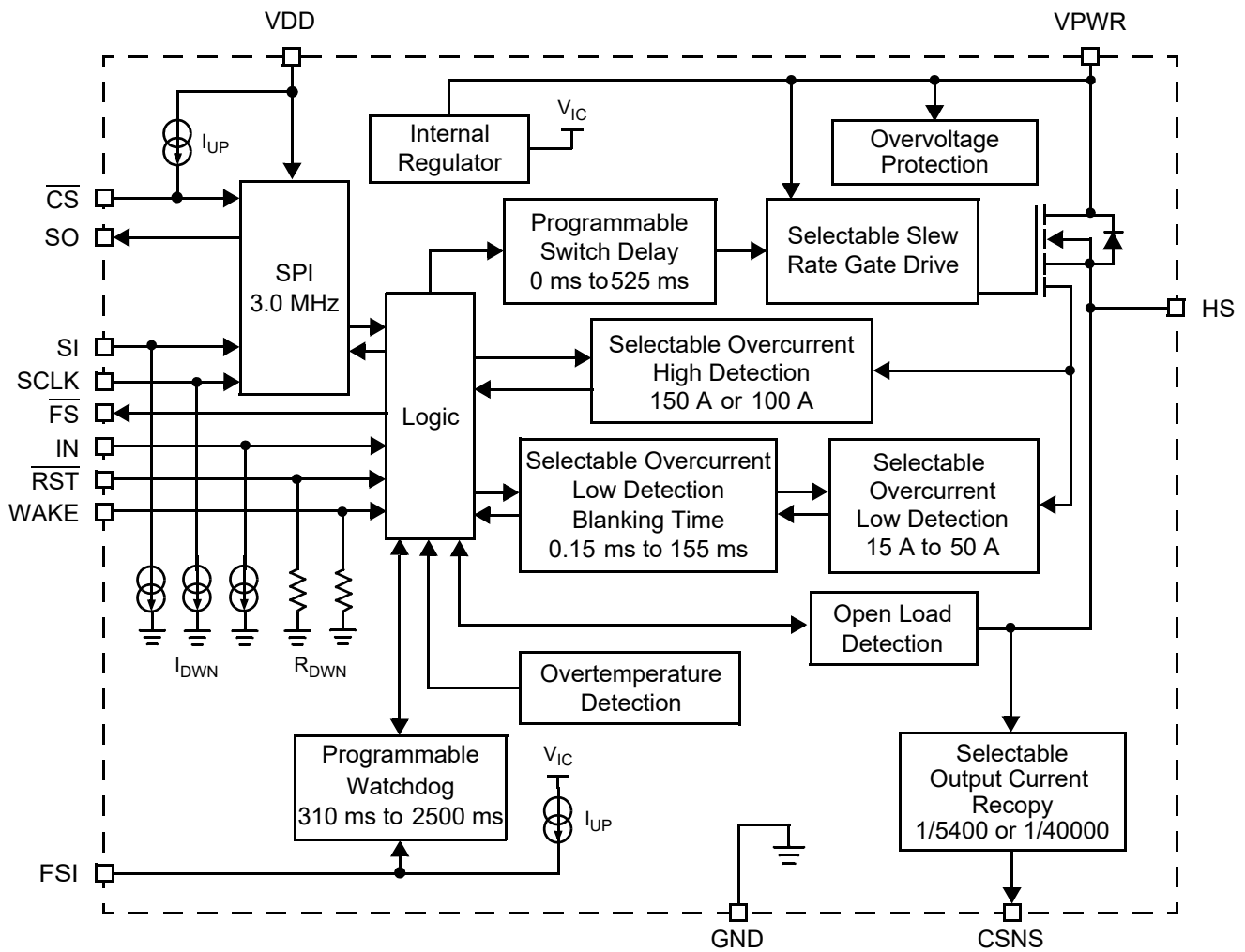
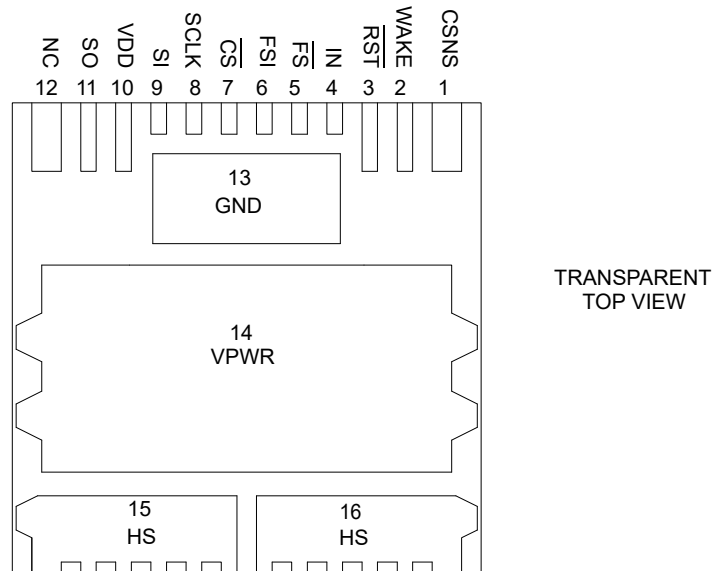

Figure 2. 33982 Simplified internal block diagram

## Pin connections



**Figure 3. 33982 pin connections**

Functional descriptions of many of these pins can be found in the Functional Pin Description section beginning on [page 17](#).

**Table 2. Pin definitions**

Pin Number	Pin Name	Pin Function	Formal Name	Definition
1	CSNS	Output	Output Current Monitoring	This pin is used to output a current proportional to the high-side output current and used externally to generate a ground-referenced voltage for the microcontroller to monitor output current.
2	WAKE	Input	Wake	This pin is used to input a logic [1] signal in order to enable the watchdog timer function.
3	$\overline{\text{RST}}$	Input	Reset (Active Low)	This input pin is used to initialize the device configuration and fault registers, as well as place the device in a low current sleep mode.
4	IN	Input	Direct Input	The Input pin is used to directly control the output.
5	$\overline{\text{FS}}$	Output	Fault Status (Active Low)	This is an open drain configured output requiring an external pull-up resistor to VDD for fault reporting.
6	FSI	Input	Fail-Safe Input	The value of the resistance connected between this pin and ground determines the state of the output after a watchdog timeout occurs.
7	$\overline{\text{CS}}$	Input	Chip Select (Active Low)	This input pin is connected to a chip select output of a master microcontroller (MCU).
8	SCLK	Input	Serial Clock	This input pin is connected to the MCU providing the required bit shift clock for SPI communication.
9	SI	Input	Serial Input	This is a command data input pin connected to the SPI Serial Data Output of the MCU or to the SO pin of the previous device in a daisy chain of devices.
10	VDD	Input	Digital Drain Voltage (Power)	This is an external voltage input pin used to supply power to the SPI circuit.
11	SO	Output	Serial Output	This output pin is connected to the SPI Serial Data Input pin of the MCU or to the SI pin of the next device in a daisy chain of devices.
12	NC	NC	No Connect	This pin may not be connected.

**Table 2. Pin definitions (continued)**

Pin Number	Pin Name	Pin Function	Formal Name	Definition
13	GND	Ground	Ground	This pin is the ground for the logic and analog circuitry of the device.
14	VPWR	Input	Positive Power Supply	This pin connects to the positive power supply and is the source input of operational power for the device.
15, 16	HS	Output	High-side Output	Protected high-side power output to the load. Output pins must be connected in parallel for operation.

## Electrical characteristics

### Maximum ratings

**Table 3. Maximum ratings**

All voltages are with respect to ground unless otherwise noted.

Symbol	Rating	Value	Unit	Notes
<b>ELECTRICAL RATINGS</b>				
$V_{PWR}$	Operating Voltage Range Steady-state	-16 to 41	V	
$V_{DD}$	VDD Supply Voltage	-0.3 to 5.5	V	
$V_{IN}, \overline{RST}, FSI,$ $CSNS, SI, SCLK,$ $CS, \overline{FS}$	Input/Output Voltage	-0.3 to 7.0	V	(2)
$V_{SO}$	SO Output Voltage	-0.3 to $V_{DD}+0.3$	V	(2)
$I_{CL(WAKE)}$	WAKE Input Clamp Current	2.5	mA	
$I_{CL(CSNS)}$	CSNS Input Clamp Current	10	mA	
$I_{HS}$	Output Current	60	A	(3)
$V_{HS}$	Output Voltage Positive Negative	41 -15	V	
$E_{CL}$	Output Clamp Energy 33982C 33982E	1.0 0.6	J	(4)
$V_{ESD1}$ $V_{ESD3}$	ESD Voltage Human Body Model (HBM) Charge Device Model (CDM) Corner Pins (1, 12, 15, 16) All Other Pins (2, 11, 13, 14)	$\pm 2000$  $\pm 750$ $\pm 500$	V	(5)

**Notes**

- Exceeding this voltage limit may cause permanent damage to the device.
- Continuous high-side output current rating so long as maximum junction temperature is not exceeded. Calculation of maximum output current using package thermal resistance is required.
- Active clamp energy using single-pulse method ( $L = 16$  mH,  $R_L = 0$ ,  $V_{PWR} = 12$  V,  $T_J = 150^\circ\text{C}$ ).
- ESD1 testing is performed in accordance with the Human Body Model (HBM) ( $C_{ZAP} = 100$  pF,  $R_{ZAP} = 1500$   $\Omega$ ); ESD3 testing is performed in accordance with the Charge Device Model (CDM), Robotic ( $C_{zap} = 4.0$  pF).

**Table 3. Maximum ratings**

All voltages are with respect to ground unless otherwise noted.

Symbol	Rating	Value	Unit	Notes
<b>THERMAL RATINGS</b>				
$T_A$ $T_J$	Operating Temperature Ambient Junction	-40 to 125 -40 to 150	°C	
$T_{STG}$	Storage Temperature	-55 to 150	°C	
$R_{\theta JC}$ $R_{\theta JA}$	Thermal Resistance Junction-to-Case Junction-to-Ambient	<1.0 30	°C/W	(6)
$T_{PPRT}$	Peak Package Reflow Temperature During Reflow	Note 8	°C	(7), (8)

## Notes

6. Device mounted on a 2s2p test board per JEDEC JESD51-2.
7. Pin soldering temperature limit is for 40 seconds maximum duration. Not designed for immersion soldering. Exceeding these limits may cause malfunction or permanent damage to the device.
8. NXP's Package Reflow capability meets Pb-free requirements for JEDEC standard J-STD-020C. For Peak Package Reflow Temperature and Moisture Sensitivity Levels (MSL), Go to [www.nxp.com](http://www.nxp.com), search by part number [e.g. remove prefixes/suffixes and enter the core ID to view all orderable parts. (i.e. MC33xxxD enter 33xxx), and review parametrics.

**Static electrical characteristics****Table 4. Static electrical characteristics**

Characteristics noted under conditions  $4.5\text{ V} \leq V_{DD} \leq 5.5\text{ V}$ ,  $6.0\text{ V} \leq V_{PWR} \leq 27\text{ V}$ ,  $-40\text{ }^\circ\text{C} \leq T_A \leq 125\text{ }^\circ\text{C}$ , unless otherwise noted. Typical values noted reflect the approximate parameter mean at  $T_A = 25\text{ }^\circ\text{C}$  under nominal conditions, unless otherwise noted.

Symbol	Characteristic	Min	Typ	Max	Unit	Notes
<b>POWER INPUT</b>						
$V_{PWR}$	Battery Supply Voltage Range Full Operational	6.0	–	27	V	
$I_{PWR(ON)}$	VPWR Operating Supply Current Output ON, $I_{HS} = 0\text{ A}$	–	–	20	mA	
$I_{PWR(SBY)}$	VPWR Supply Current Output OFF, Open Load Detection Disabled, WAKE > 0.7 $V_{DD}$ , $RST = V_{LOGIC\ HIGH}$	–	–	5.0	mA	
$I_{PWR(SLEEP)}$	Sleep State Supply Current ( $V_{PWR} < 14\text{ V}$ , $\overline{RST} < 0.5\text{ V}$ , WAKE < 0.5 V) $T_J = 25\text{ }^\circ\text{C}$ $T_J = 85\text{ }^\circ\text{C}$	– –	– –	10 50	$\mu\text{A}$	
$V_{DD(ON)}$	VDD Supply Voltage	4.5	5.0	5.5	V	
$I_{DD(ON)}$	VDD Supply Current No SPI Communication 3.0 MHz SPI Communication	– –	– –	1.0 5.0	mA	
$I_{DD(SLEEP)}$	VDD Sleep State Current	–	–	5.0	$\mu\text{A}$	
$V_{PWR(OV)}$	Overvoltage Shutdown Threshold	28	32	36	V	
$V_{PWR(OVHYS)}$	Overvoltage Shutdown Hysteresis	0.2	0.8	1.5	V	
$V_{PWR(UV)}$	Undervoltage Output Shutdown Threshold	5.0	5.5	6.0	V	(9)
$V_{PWR(UVHYS)}$	Undervoltage Hysteresis	–	0.25	–	V	(10)
$V_{PWR(UVPOR)}$	Undervoltage Power-ON Reset	–	–	5.0	V	
<b>POWER OUTPUT</b>						
$R_{DS(on)}$	Output Drain-to-Source ON Resistance ( $I_{HS} = 30\text{ A}$ , $T_J = 25\text{ }^\circ\text{C}$ ) $V_{PWR} = 6.0\text{ V}$ $V_{PWR} = 10\text{ V}$ $V_{PWR} = 13\text{ V}$	– – –	– – –	3.0 2.0 2.0	$\text{m}\Omega$	
$R_{DS(on)}$	Output Drain-to-Source ON Resistance ( $I_{HS} = 30\text{ A}$ , $T_J = 150\text{ }^\circ\text{C}$ ) $V_{PWR} = 6.0\text{ V}$ $V_{PWR} = 10\text{ V}$ $V_{PWR} = 13\text{ V}$	– – –	– – –	5.1 3.4 3.4	$\text{m}\Omega$	
$R_{DS(on)}$	Output Source-to-Drain ON Resistance ( $I_{HS} = 30\text{ A}$ , $T_J = 25\text{ }^\circ\text{C}$ ) $V_{PWR} = -12\text{ V}$	–	2.0	4.0	$\text{m}\Omega$	(11)
$I_{OCH0}$ $I_{OCH1}$	Output Overcurrent High Detection Levels ( $9.0\text{ V} \leq V_{PWR} \leq 16\text{ V}$ ) SOCH = 0 CHFK EHFK SOCH = 1 CHFK EHFK	120 107 80 72	150 137 100 92	180 167 120 112	A	

**Notes**

9. This applies to all internal device logic that is supplied by  $V_{PWR}$  and assumes that the external  $V_{DD}$  supply is within specification.
10. This applies when the undervoltage fault is not latched ( $IN = 0$ ).
11. Source-Drain ON Resistance (Reverse Drain-to-Source ON Resistance) with negative polarity  $V_{PWR}$ .

**Table 4. Static electrical characteristics (continued)**

Characteristics noted under conditions  $4.5\text{ V} \leq V_{DD} \leq 5.5\text{ V}$ ,  $6.0\text{ V} \leq V_{PWR} \leq 27\text{ V}$ ,  $-40\text{ }^\circ\text{C} \leq T_A \leq 125\text{ }^\circ\text{C}$ , unless otherwise noted. Typical values noted reflect the approximate parameter mean at  $T_A = 25\text{ }^\circ\text{C}$  under nominal conditions, unless otherwise noted.

Symbol	Characteristic	Min	Typ	Max	Unit	Notes
<b>POWER OUTPUT (CONTINUED)</b>						
$I_{OCL0}$ $I_{OCL1}$ $I_{OCL2}$ $I_{OCL3}$ $I_{OCL4}$ $I_{OCL5}$ $I_{OCL6}$ $I_{OCL7}$	Overcurrent Low Detection Levels (SOCL[2:0]) CHFK 000 001 010 011 100 101 110 111	41 36 32 29 25 20 16 12	50 45 40 35 30 25 20 15	59 54 48 41 35 30 24 18	A	
$I_{OCL0}$ $I_{OCL1}$ $I_{OCL2}$ $I_{OCL3}$ $I_{OCL4}$ $I_{OCL5}$ $I_{OCL6}$ $I_{OCL7}$	Overcurrent Low Detection Levels (SOCL[2:0]) EHKF 000 001 010 011 100 101 110 111	37 33 29 26 23 18 14 11	46 42 37 32 28 23 18 14	55 51 45 38 33 28 22 17	A	
$C_{SR0}$ $C_{SR1}$	Current Sense Ratio ( $9.0\text{ V} \leq V_{PWR} \leq 16\text{ V}$ , $CSNS \leq 4.5\text{ V}$ ) CHFK DICR D2 = 0 DICR D2 = 1	– –	1/5400 1/40000	– –	– –	
$C_{SR0}$ $C_{SR1}$	Current Sense Ratio ( $9.0\text{ V} \leq V_{PWR} \leq 16\text{ V}$ , $CSNS \leq 4.5\text{ V}$ ) EHKF DICR D2 = 0 DICR D2 = 1	– –	1/4900 1/34700	– –	– –	
$C_{SR0\_ACC}$	Current Sense Ratio ( $C_{SR0}$ ) Accuracy Output Current 10 A 20 A 25 A 30 A 40 A 50 A	–20 –14 –13 –12 –13 –13	– – – – – –	20 14 13 12 13 13	%	
$C_{SR1\_ACC}$	Current Sense Ratio ( $C_{SR1}$ ) Accuracy Output Current 10 A 20 A 25 A 30 A 40 A 50 A	–25 –19 –18 –17 –18 –18	– – – – – –	25 19 18 17 18 18	%	
$V_{CL(CSNS)}$	Current Sense Clamp Voltage CSNS Open, $I_{HS} = 59.0\text{ A}$	4.5	6.0	7.0	V	
$I_{LEAK(CSNS)}$	Current Sense Leakage IN = 1 with OUT opened of load or IN = 0	0.0	10	20	$\mu\text{A}$	(12)
$I_{OLDC}$	Open Load Detection Current	30	–	100	$\mu\text{A}$	(13)
$V_{OLD(THRES)}$	Output Fault Detection Threshold Output Programmed OFF	2.0	3.0	4.0	V	

**Table 4. Static electrical characteristics (continued)**

Characteristics noted under conditions  $4.5\text{ V} \leq V_{DD} \leq 5.5\text{ V}$ ,  $6.0\text{ V} \leq V_{PWR} \leq 27\text{ V}$ ,  $-40\text{ }^{\circ}\text{C} \leq T_A \leq 125\text{ }^{\circ}\text{C}$ , unless otherwise noted. Typical values noted reflect the approximate parameter mean at  $T_A = 25\text{ }^{\circ}\text{C}$  under nominal conditions, unless otherwise noted.

Symbol	Characteristic	Min	Typ	Max	Unit	Notes
$V_{CL}$	Output Negative Clamp Voltage $0.5\text{ A} \leq I_{HS} \leq 2.0\text{ A}$ , Output OFF	-20	–	-15	V	
$T_{SD}$	Overtemperature Shutdown	160	175	190	$^{\circ}\text{C}$	(14)
$T_{SD(HYS)}$	Overtemperature Shutdown Hysteresis	5.0	–	20	$^{\circ}\text{C}$	(14)

## Notes

12. This parameter is achieved by the design characterization by measuring a statistically relevant sample size across process variations but, not tested in production.
13. Output OFF open load detection current is the current required to flow through the load for the purpose of detecting the existence of an open load condition when the specific output is commanded OFF.
14. Guaranteed by process monitoring. Not production tested.

**Table 4. Static electrical characteristics (continued)**

Characteristics noted under conditions  $4.5\text{ V} \leq V_{DD} \leq 5.5\text{ V}$ ,  $6.0\text{ V} \leq V_{PWR} \leq 27\text{ V}$ ,  $-40\text{ }^\circ\text{C} \leq T_A \leq 125\text{ }^\circ\text{C}$ , unless otherwise noted. Typical values noted reflect the approximate parameter mean at  $T_A = 25\text{ }^\circ\text{C}$  under nominal conditions, unless otherwise noted.

Symbol	Characteristic	Min	Typ	Max	Unit	Notes
<b>CONTROL INTERFACE</b>						
$V_{IH}$	Input Logic High-voltage	$0.7 \times V_{DD}$	–	–	V	(15)
$V_{IL}$	Input Logic Low-voltage	–	–	$0.2 \times V_{DD}$	V	(15)
$V_{IN(HYS)}$	Input Logic Voltage Hysteresis	100	600	1200	mV	(16)
$I_{DWN}$	Input Logic Pull-down Current (SCLK, IN, SI)	5.0	–	20	$\mu\text{A}$	
$V_{RST}$	$\overline{\text{RST}}$ Input Voltage Range	4.5	5.0	5.5	V	
$C_{SO}$	SO, $\overline{\text{FS}}$ Tri-state Capacitance	–	–	20	pF	(17)
$R_{DWN}$	Input Logic Pull-down Resistor ( $\overline{\text{RST}}$ ) and WAKE	100	200	400	$\text{k}\Omega$	
$C_{IN}$	Input Capacitance	–	4.0	12	pF	(17)
$V_{CL(WAKE)}$	WAKE Input Clamp Voltage $I_{CL(WAKE)} < 2.5\text{ mA}$	7.0	–	14	V	(18)
$V_{F(WAKE)}$	WAKE Input Forward Voltage $I_{CL(WAKE)} = -2.5\text{ mA}$	-2.0	–	-0.3	V	
$V_{SOH}$	SO High-state Output Voltage $I_{OH} = 1.0\text{ mA}$	$0.8 \times V_{DD}$	–	–	V	
$V_{SOL}$	$\overline{\text{FS}}$ , SO Low-state Output Voltage $I_{OL} = -1.6\text{ mA}$	–	0.2	0.4	V	
$I_{SO(LEAK)}$	SO Tri-state Leakage Current $\text{CS} \geq 0.7 \times V_{DD}$	-5.0	0.0	5.0	$\mu\text{A}$	
$I_{UP}$	Input Logic Pull-up Current $\overline{\text{CS}}$ , $V_{IN} > 0.7 \times V_{DD}$	5.0	–	20	$\mu\text{A}$	(19)
$R_{FS}$ $R_{FSDIS}$ $R_{FSOFF}$ $R_{FSON}$	FSI Input Pin External Pull-down Resistance FSI Disabled, HS Indeterminate FSI Enabled, HS OFF FSI Enabled, HS ON	– 6.0 30	0.0 10 –	1.0 14 –	$\text{k}\Omega$	

**Notes**

- Upper and lower logic threshold voltage range applies to SI,  $\overline{\text{CS}}$ , SCLK,  $\overline{\text{RST}}$ , IN, and WAKE input signals. The WAKE and  $\overline{\text{RST}}$  signals may be supplied by a derived voltage reference to  $V_{PWR}$ .
- No hysteresis on FSI and wake pins. Parameter is guaranteed by process monitoring but is not production tested.
- Input capacitance of SI,  $\overline{\text{CS}}$ , SCLK,  $\overline{\text{RST}}$ , and WAKE. This parameter is guaranteed by process monitoring but is not production tested.
- The current must be limited by a series resistance when using voltages  $> 7.0\text{ V}$ .
- Pull-up current is with  $\overline{\text{CS}}$  OPEN.  $\overline{\text{CS}}$  has an active internal pull-up to  $V_{DD}$ .

**Dynamic electrical characteristics****Table 5. Dynamic electrical characteristics**

Characteristics noted under conditions  $4.5\text{ V} \leq V_{DD} \leq 5.5\text{ V}$ ,  $6.0\text{ V} \leq V_{PWR} \leq 27\text{ V}$ ,  $-40^\circ\text{C} \leq T_A \leq 125^\circ\text{C}$ , unless otherwise noted. Typical values noted reflect the approximate parameter mean at  $T_A = 25^\circ\text{C}$  under nominal conditions, unless otherwise noted.

Symbol	Characteristic	Min	Typ	Max	Unit	Notes
<b>POWER OUTPUT TIMING</b>						
SR <sub>RA_SLOW</sub>	Output Rising Slow Slewing Rate A (DICR D3 = 0) 9.0 V < V <sub>PWR</sub> < 16 V CHFK EHFK	0.15 0.15	0.5 0.5	1.0 1.5	V/ $\mu$ s	(20)
SR <sub>RB_SLOW</sub>	Output Rising Slow Slewing Rate B (DICR D3 = 0) 9.0 V < V <sub>PWR</sub> < 16 V	0.06	0.2	0.6	V/ $\mu$ s	(21)
SR <sub>RA_FAST</sub>	Output Rising Fast Slewing Rate A (DICR D3 = 1) 9.0 V < V <sub>PWR</sub> < 16 V CHFK EHFK	0.3 0.3	0.8 0.8	3.2 3.4	V/ $\mu$ s	(20)
SR <sub>RB_FAST</sub>	Output Rising Fast Slewing Rate B (DICR D3 = 1) 9.0 V < V <sub>PWR</sub> < 16 V	0.06	0.2	2.4	V/ $\mu$ s	(21)
SR <sub>FA_SLOW</sub>	Output Falling Slow Slewing Rate A (DICR D3 = 0) 9.0 V < V <sub>PWR</sub> < 16 V CHFK EHFK	0.15 0.15	0.5 0.5	1.0 1.5	V/ $\mu$ s	(20)
SR <sub>FB_SLOW</sub>	Output Falling Slow Slewing Rate B (DICR D3 = 0) 9.0 V < V <sub>PWR</sub> < 16 V	0.06	0.2	0.6	V/ $\mu$ s	(21)
SR <sub>FA_FAST</sub>	Output Falling Fast Slewing Rate A (DICR D3 = 1) 9.0 V < V <sub>PWR</sub> < 16 V CHFK EHFK	0.6 0.6	1.6 1.6	3.2 5.6	V/ $\mu$ s	(20)
SR <sub>FB_FAST</sub>	Output Falling Fast Slewing Rate B (DICR D3 = 1) 9.0 V < V <sub>PWR</sub> < 16 V	0.2	0.7	2.4	V/ $\mu$ s	(21)
t <sub>DLY(ON)</sub>	Output Turn-ON Delay Time in Fast/Slow Slewing Rate DICR = 0, DICR = 1 CHFK EHFK	1.0 0.1	18 18	100 100	$\mu$ s	(22)
t <sub>DLY_SLOW(OFF)</sub>	Output Turn-OFF Delay Time in Slow Slewing Rate Mode DICR = 0 CHFK EHFK	10 0.1	115 115	250 250	$\mu$ s	(23)
t <sub>DLY_FAST(OFF)</sub>	Output Turn-OFF Delay Time in Fast Slewing Rate Mode DICR = 1 CHFK EHFK	5.0 0.1	30 30	100 100	$\mu$ s	(23)
f <sub>PWM</sub>	Direct Input Switching Frequency (DICR D3 = 0)	–	300	–	Hz	
t <sub>OCL0</sub> t <sub>OCL1</sub> t <sub>OCL2</sub> t <sub>OCL3</sub>	Overcurrent Low Detection Blanking Time (OCLT[1:0]) 00 01 10 11	108 7.0 0.8 0.08	155 10 1.2 0.15	202 13 1.6 0.25	ms	
t <sub>OCH</sub>	Overcurrent High Detection Blanking Time	1.0	10	20	$\mu$ s	

**Notes**

- Rise and Fall Slewing Rates A measured across a 5.0  $\Omega$  resistive load at high-side output = 0.5 V to V<sub>PWR</sub>-3.5 V. These parameters are guaranteed by process monitoring.
- Rise and Fall Slow Slewing Rates B measured across a 5.0  $\Omega$  resistive load at high-side output = V<sub>PWR</sub>-3.5 V to V<sub>PWR</sub>-0.5 V. These parameters are guaranteed by process monitoring.
- Turn-ON delay time measured from rising edge of any signal (IN, SCLK,  $\overline{\text{CS}}$ ) that would turn the output ON to V<sub>HS</sub> = 0.5 V with R<sub>L</sub> = 5.0  $\Omega$  resistive load.
- Turn-OFF delay time measured from falling edge of any signal (IN, SCLK,  $\overline{\text{CS}}$ ) that would turn the output OFF to V<sub>HS</sub> = V<sub>PWR</sub>-0.5 V with R<sub>L</sub> = 5.0  $\Omega$  resistive load.

**Table 5. Dynamic electrical characteristics (continued)**

Characteristics noted under conditions  $4.5\text{ V} \leq V_{DD} \leq 5.5\text{ V}$ ,  $6.0\text{ V} \leq V_{PWR} \leq 27\text{ V}$ ,  $-40^\circ\text{C} \leq T_A \leq 125^\circ\text{C}$ , unless otherwise noted. Typical values noted reflect the approximate parameter mean at  $T_A = 25^\circ\text{C}$  under nominal conditions, unless otherwise noted.

Symbol	Characteristic	Min	Typ	Max	Unit	Notes
<b>POWER OUTPUT TIMING (CONTINUED)</b>						
$t_{\text{CNSVAL}}$	$\overline{\text{CS}}$ to CSNS Valid Time	–	–	10	$\mu\text{s}$	(24)
	Output Switching Delay Time (OSD[2:0])					
$t_{\text{OSD0}}$	000	–	0.0	–		
$t_{\text{OSD1}}$	001	52	75	95		
$t_{\text{OSD2}}$	010	105	150	195		
$t_{\text{OSD3}}$	011	157	225	293	ms	
$t_{\text{OSD4}}$	100	210	300	390		
$t_{\text{OSD5}}$	101	262	375	488		
$t_{\text{OSD6}}$	110	315	450	585		
$t_{\text{OSD7}}$	111	367	525	683		
	Watchdog Timeout (WD[1:0])					
$t_{\text{WDTO0}}$	00	434	620	806		
$t_{\text{WDTO1}}$	01	207	310	403	ms	(25)
$t_{\text{WDTO2}}$	10	1750	2500	3250		
$t_{\text{WDTO3}}$	11	875	1250	1625		
<b>SPI INTERFACE CHARACTERISTICS</b>						
$f_{\text{SPI}}$	Recommended Frequency of SPI Operation	–	–	3.0	MHz	
$t_{\text{WRST}}$	Required Low-state Duration for $\overline{\text{RST}}$	–	50	167	ns	(26)

## Notes

24. Time necessary for the CSNS to be within  $\pm 5\%$  of the targeted value.
25. Watchdog timeout delay measured from the rising edge of WAKE to  $\overline{\text{RST}}$  from a sleep state condition to output turn-ON with the output driven OFF and FSI floating. The values shown are for WDR setting of [00]. The accuracy of  $t_{\text{WDTO}}$  is consistent for all configured watchdog timeouts.
26.  $\overline{\text{RST}}$  low duration measured with outputs enabled and going to OFF or disabled condition.

**Table 5. Dynamic electrical characteristics (continued)**

Characteristics noted under conditions  $4.5\text{ V} \leq V_{DD} \leq 5.5\text{ V}$ ,  $6.0\text{ V} \leq V_{PWR} \leq 27\text{ V}$ ,  $-40^\circ\text{C} \leq T_A \leq 125^\circ\text{C}$ , unless otherwise noted. Typical values noted reflect the approximate parameter mean at  $T_A = 25^\circ\text{C}$  under nominal conditions, unless otherwise noted.

Symbol	Characteristic	Min	Typ	Max	Unit	Notes
<b>SPI INTERFACE CHARACTERISTICS</b>						
$t_{\overline{\text{CS}}}$	Rising Edge of $\overline{\text{CS}}$ to Falling Edge of $\overline{\text{CS}}$ (Required Setup Time)	–	–	300	ns	(27)
$t_{\text{ENBL}}$	Rising Edge of $\overline{\text{RST}}$ to Falling Edge of $\overline{\text{CS}}$ (Required Setup Time)	–	–	5.0	$\mu\text{s}$	(27)
$t_{\text{LEAD}}$	Falling Edge of $\overline{\text{CS}}$ to Rising Edge of SCLK (Required Setup Time)	–	50	167	ns	(27)
$t_{\text{WSCLKH}}$	Required High-state Duration of SCLK (Required Setup Time)	–	–	167	ns	(27)
$t_{\text{WSCLKL}}$	Required Low-state Duration of SCLK (Required Setup Time)	–	–	167	ns	(27)
$t_{\text{LAG}}$	Falling Edge of SCLK to Rising Edge of $\overline{\text{CS}}$ (Required Setup Time)	–	50	167	ns	(27)
$t_{\text{SI(SU)}}$	SI to Falling Edge of SCLK (Required Setup Time)	–	25	83	ns	(28)
$t_{\text{SI(HOLD)}}$	Falling Edge of SCLK to SI (Required Setup Time)	–	25	83	ns	(28)
$t_{\text{RSO}}$	SO Rise Time $C_L = 200\text{ pF}$	–	25	50	ns	
$t_{\text{FSO}}$	SO Fall Time $C_L = 200\text{ pF}$	–	25	50	ns	
$t_{\text{RSI}}$	SI, $\overline{\text{CS}}$ , SCLK, Incoming Signal Rise Time	–	–	50	ns	(28)
$t_{\text{FSI}}$	SI, $\overline{\text{CS}}$ , SCLK, Incoming Signal Fall Time	–	–	50	ns	(28)
$t_{\text{SO(EN)}}$	Time from Falling Edge of $\overline{\text{CS}}$ to SO Low-impedance	–	–	145	ns	(29)
$t_{\text{SO(DIS)}}$	Time from Rising Edge of $\overline{\text{CS}}$ to SO High-impedance	–	65	145	ns	(30)
$t_{\text{VALID}}$	Time from Rising Edge of SCLK to SO Data Valid $0.2 V_{DD} \leq \text{SO} \leq 0.8 V_{DD}$ , $C_L = 200\text{ pF}$	–	65	105	ns	(31)

**Notes**

27. Maximum setup time required for the 33982 is the minimum guaranteed time needed from the microcontroller.
28. Rise and Fall time of incoming SI,  $\overline{\text{CS}}$ , and SCLK signals suggested for design consideration to prevent the occurrence of double pulsing.
29. Time required for output status data to be available for use at SO. 1.0 k $\Omega$  on pull-up on  $\overline{\text{CS}}$ .
30. Time required for output status data to be terminated at SO. 1.0 k $\Omega$  on pull-up on  $\overline{\text{CS}}$ .
31. Time required to obtain valid data out from SO following the rise of SCLK.

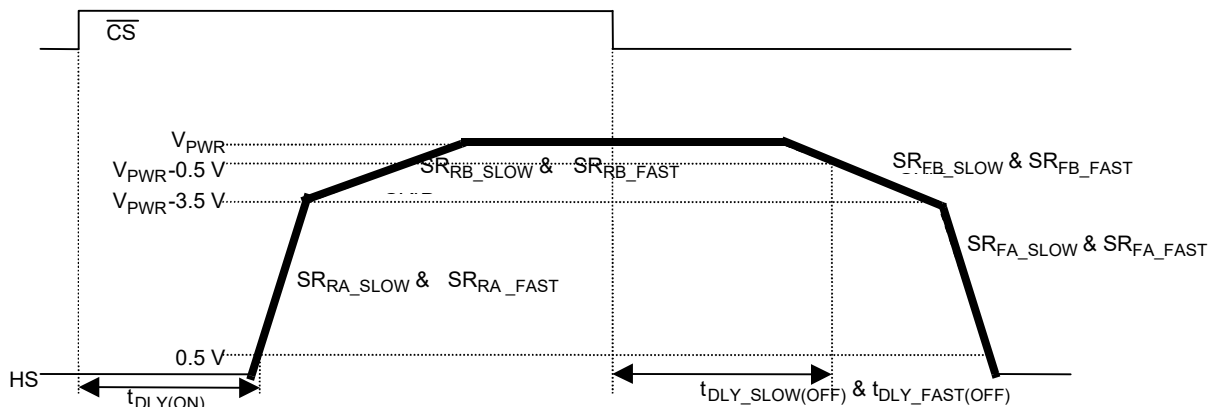
**Timing diagrams****Figure 4. Output slew rate and time delays**

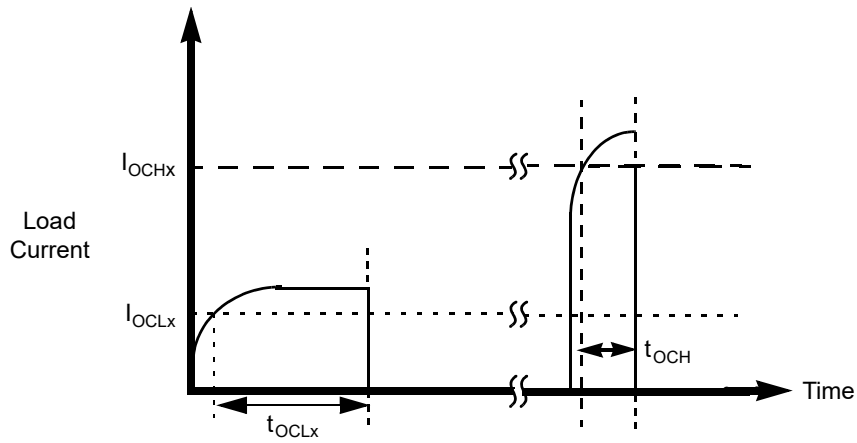

Figure 5. Overcurrent shutdown

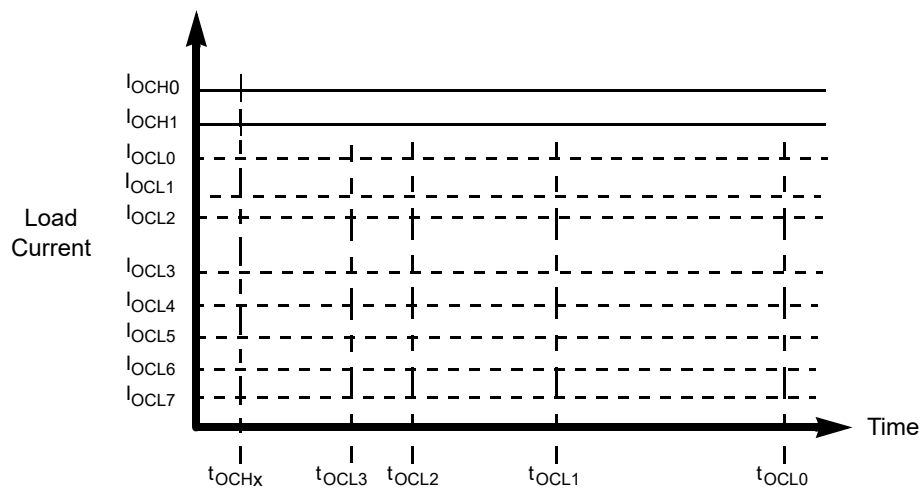

Figure 6. Overcurrent low and high detection

Figure 6 illustrates the overcurrent detection level ( $I_{OCLx}$ ,  $I_{OCHx}$ ) the device can reach for each overcurrent detection blanking time ( $t_{OCHx}$ ,  $t_{OCLx}$ ):

- During  $t_{OCHx}$ , the device can reach up to  $I_{och0}$  overcurrent level.
- During  $t_{OCL3}$  or  $t_{OCL2}$  or  $t_{OCL1}$  or  $t_{OCL0}$ , the device can be programmed to detect up to  $I_{ocl0}$ .

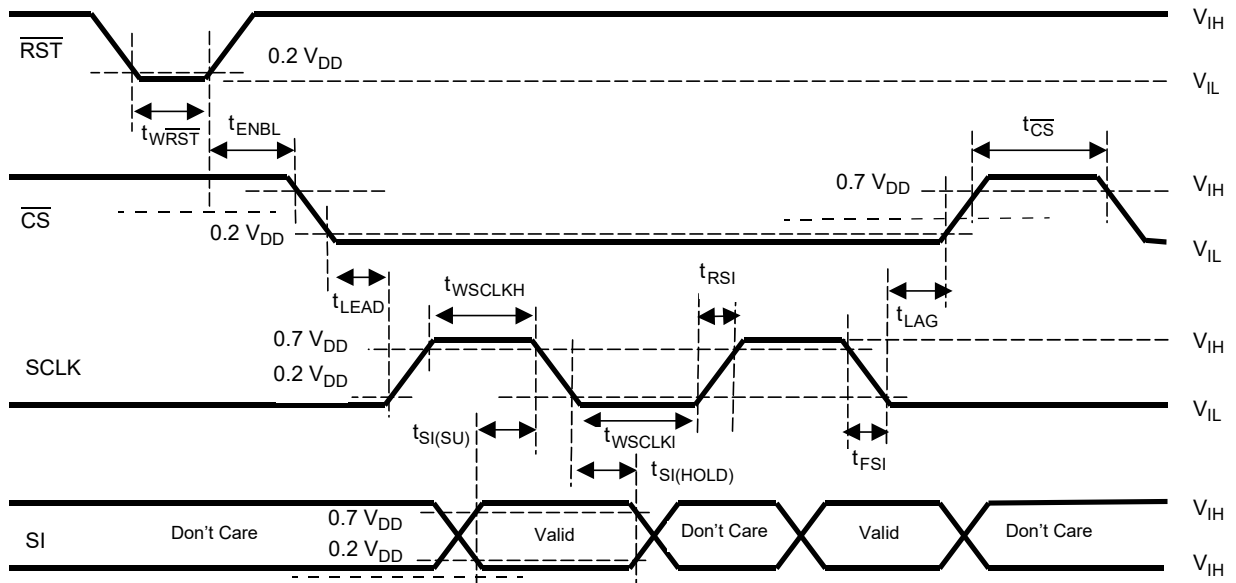

Figure 7. Input timing switching characteristics

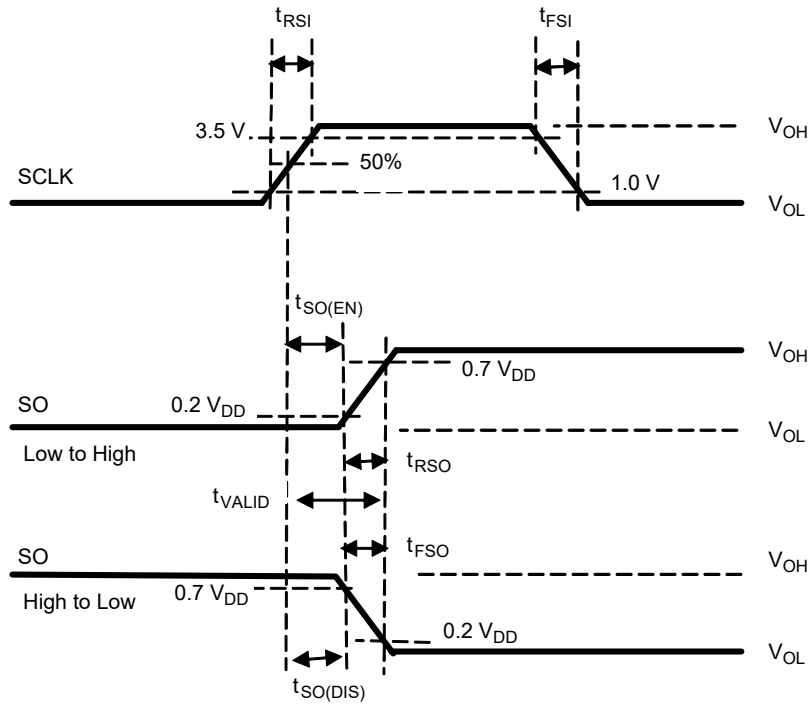

Figure 8. SCLK waveform and valid SO data delay time

## Functional description

### Introduction

The 33982 is a self-protected silicon 2.0 mΩ high-side switch used to replace electromechanical relays, fuses, and discrete devices in power management applications. The 33982 is designed for harsh environments, including self-recovery features. The device is suitable for loads with high inrush current, as well as motors and all types of resistive and inductive loads.

Programming, control, and diagnostics are implemented via the Serial Peripheral Interface (SPI). A dedicated parallel input is available for alternate and pulse width modulation (PWM) control of the output. SPI programmable fault trip thresholds allow the device to be adjusted for optimal performance in the application.

The 33982 is packaged in a power-enhanced 12 mm x 12 mm non-leaded PQFN package with exposed tabs.

### Functional pin description

#### OUTPUT CURRENT MONITORING (CSNS)

The CSNS pin outputs a current proportional to the high-side output current and used externally to generate a ground-referenced voltage for the microcontroller to monitor output current.

#### WAKE (WAKE)

This pin is used to input a logic [1] signal in order to enable the watchdog timer function. An internal clamp protects this pin from high damaging voltages when the output is current limited with an external resistor. This input has a passive internal pull-down.

#### RESET ( $\overline{\text{RST}}$ )

This input pin is used to initialize the device configuration and fault registers, as well as place the device in a low-current sleep mode. The pin also starts the watchdog timer when transitioning from logic LOW to logic HIGH. This pin should not be allowed to be logic High until  $V_{DD}$  is in regulation. This pin has a passive internal pull-down.

#### DIRECT IN (IN)

The Input pin is used to directly control the output. This input has an active internal pull-down current source and requires CMOS logic levels. This input may be configured via the SPI.

#### FAULT STATUS ( $\overline{\text{FS}}$ )

This is an open drain configured output requiring an external pull-up resistor to  $V_{DD}$  for fault reporting. When a device fault condition is detected, this pin is active LOW. Specific device diagnostic faults are reported via the SPI SO pin.

#### FAIL-SAFE INPUT (FSI)

The value of the resistance connected between this pin and ground determines the state of the output after a watchdog timeout occurs. Depending on the resistance value, either the output is OFF or ON. When the FSI pin is connected to GND, the watchdog circuit and Fail-safe operation are disabled. This pin incorporates an active internal pull-up current source.

#### CHIP SELECT ( $\overline{\text{CS}}$ )

This input pin is connected to a chip select output of a master microcontroller (MCU). The MCU determines which device is addressed (selected) to receive data by pulling the  $\overline{\text{CS}}$  pin of the selected device logic Low, enabling SPI communication with the device. Other unselected devices on the serial link having their  $\overline{\text{CS}}$  pins pulled up logic High disregard the SPI communication data sent. This pin incorporates an active internal pull-up current source.

#### SERIAL CLOCK (SCLK)

This input pin is connected to the MCU providing the required bit shift clock for SPI communication. It transitions one time per bit transferred at an operating frequency,  $f_{SPI}$ , defined by the communication interface. The 50 percent duty cycle CMOS-level serial clock signal is idle between command transfers. The signal is used to shift data into and out of the device. This input has an active internal pull-down current source.

#### SERIAL INTERFACE (SI)

This is a command data input pin connected to the SPI Serial Data Output of the MCU or to the SO pin of the previous device in a daisy chain of devices. The input requires CMOS logic level signals and incorporates an active internal pull-down current source. Device control is facilitated by the input's receiving the MSB first of a serial 8-bit control command. The MCU ensures data is available upon the falling edge of SCLK. The logic state of SI present upon the rising edge of SCLK loads that bit command into the internal command shift register.

### **DIGITAL DRAIN VOLTAGE POWER (VDD)**

This is an external voltage input pin used to supply power to the SPI circuit. In the event  $V_{DD}$  is lost, an internal supply provides power to a portion of the logic, ensuring limited functionality of the device. All device configuration registers are reset.

### **SERIAL OUTPUT (SO)**

This output pin is connected to the SPI Serial Data Input pin of the MCU or to the SI pin of the next device in a daisy chain of devices. This output remains tri-stated (high-impedance OFF condition) so long as the CS pin of the device is logic High. SO is only active when the CS pin of the device is asserted logic Low. The generated SO output signals are CMOS logic levels. SO output data is available on the falling edge of SCLK and transitions immediately on the rising edge of SCLK.

### **POSITIVE POWER SUPPLY (VPWR)**

This pin connects to the positive power supply and is the source input of operational power for the device. The VPWR pin is a backside surface mount tab of the package.

### **HIGH-SIDE OUTPUT (HS)**

This pin protects high-side power output to the load. Output pins must be connected in parallel for operation.

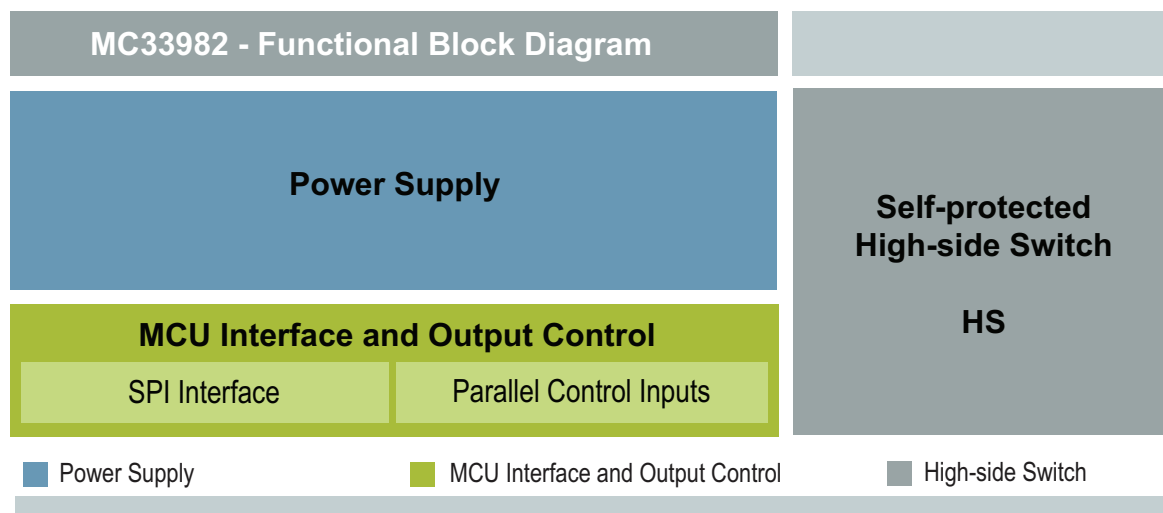
**Functional internal block description****Figure 9. Functional internal block diagram****POWER SUPPLY**

The 33982 is designed to operate from 4.0 V to 28 V on the VPWR pin. Characteristics are provided from 6.0 V to 20 V for the device. The VPWR pin supplies power to internal regulator, analog, and logic circuit blocks. The  $V_{DD}$  supply is used for serial peripheral interface (SPI) communication in order to configure and diagnose the device. This IC architecture provides a low quiescent current sleep mode. Applying  $V_{PWR}$  and  $V_{DD}$  to the device places the device in the Normal mode. The device transits to Fail-safe mode in case of failures on the SPI (watchdog timeout).

**HIGH-SIDE SWITCH: HS**

This pin is the high-side output controlling multiple automotive loads with high inrush current, as well as motors and all types of resistive and inductive loads. This N-channel MOSFET with a  $2.0\text{ m}\Omega$   $R_{DS(on)}$ , is self-protected and presents extended diagnostics to detect load disconnections and short-circuit fault conditions. The HS output is actively clamped during a turn-off of inductive loads.

**MCU INTERFACE AND OUTPUT CONTROL**

In Normal mode, the load is controlled directly from the MCU through the SPI. With a dedicated SPI command, it is possible to independently turn on and off several loads that are PWMed at the same frequency, and duty cycles with only one PWM signal. An analog feedback output provides a current proportional to the load current. The SPI is used to configure and to read the diagnostic status (faults) of high-side output. The reported fault conditions are: open load, short-circuit to ground (OCLO-resistive and OCHI-severe short-circuit), thermal shutdown, and under/overvoltage.

In Fail-safe mode, the load is controlled with dedicated parallel input pins. The device is configured in default mode.

## Functional device operation

### Operational modes

The 33982 has four operating modes: Sleep, Normal, Fault, and Fail-safe. [Table 6](#) summarizes details contained in succeeding paragraphs.

**Table 6. Fail-safe operation and transitions to other 33982 modes**

Mode	$\overline{\text{FS}}$	WAKE	RST	WDTO	Comments
Sleep	x	0	0	x	Device is in Sleep mode. All outputs are OFF.
Normal	1	x	1	No	Normal mode. Watchdog is active if enabled.
Fault	0	1	x	No	The device is currently in Fault mode. The faulted output is OFF.
	0	x	1		
Fail-safe	1	0	1	Yes	Watchdog has timed out and the device is in Fail-safe mode. The output is as configured with the RFS resistor connected to FSI. RST and WAKE must be transitioned to logic [0] simultaneously to bring the device out of the Fail-safe mode or momentarily tied the FSI pin to ground.
	1	1	1		
	1	0	1		
	1	1	0		

x = Don't care.

### SLEEP MODE

The default mode of the 33982 is the Sleep mode. This is the state of the device after first applying battery voltage ( $V_{PWR}$ ), prior to any I/O transitions. This is also the state of the device when the WAKE and RST are both logic [0]. In the Sleep mode, the output and all unused internal circuitry, such as the internal 5.0 V regulator, are off to minimize current draw. In addition, all SPI-configurable features of the device are as if set to logic [0]. The device transitions to the Normal or Fail-safe operating modes based on the WAKE and RST inputs as defined in [Table 6](#).

### NORMAL MODE

The 33982 is in Normal mode when:

- $V_{PWR}$  is within the normal voltage range.
- RST pin is logic [1].
- No fault has occurred.

### FAIL-SAFE MODE AND WATCHDOG

If the FSI input is not grounded, the watchdog timeout detection is active when either the WAKE or  $\overline{\text{RST}}$  input pin transitions from logic [0] to logic [1]. The WAKE input is capable of being pulled up to  $V_{PWR}$  with a series of limiting resistance that limits the internal clamp current. The watchdog timeout is a multiple of an internal oscillator and is specified in [Table 15](#). As long as the WD bit (D7) of an incoming SPI message is toggled within the minimum watchdog timeout period (WDTO), based on the programmed value of the WDR the device operates normally. If an internal watchdog timeout occurs before the WD bit, the device reverts to a Fail-safe mode until the device is reinitialized.

During the Fail-safe mode, the output is ON or OFF depending upon the resistor RFS connected to the FSI pin, regardless of the state of the various direct inputs and modes ([Table 7](#)). In this mode, the SPI register content is retained except for overcurrent high and low detection levels and timing, which are reset to their default value (SOCL, SOCH, OCLT). The watchdog, overvoltage, overtemperature, and overcurrent circuitry (with default value for this one) are fully operational.

**Table 7. Output state during fail-safe mode**

RFS (k $\Omega$ )	High-side State
0	Fail-safe Mode Disabled
10	HS OFF
30	HS ON

The Fail-safe mode can be detected by monitoring the WDTO bit D2 of the WDR register. This bit is logic [1] when the device is in Fail-safe mode. The device can be brought out of the Fail-safe mode by transitioning the WAKE and  $\overline{\text{RST}}$  pins from logic [1] to logic [0] or forcing the FSI pin to logic [0]. [Table 6](#) summarizes the various methods for resetting the device from the latched Fail-safe mode.

If the FSI pin is tied to GND, the Watchdog Fail-safe operation is disabled.

## LOSS OF V<sub>DD</sub>

If the external 5.0 V supply is not within specification, or even disconnected, all register content is reset. The output can still be driven by the direct input IN. The 33982 uses the battery input to power the output MOSFET related current sense circuitry, and any other internal logic, providing fail-safe device operation with no V<sub>DD</sub> supplied. In this state, the watchdog, overvoltage, overtemperature, and overcurrent circuitry are fully operational with default values. Current recopy is active with the default current recopy value.

## FAULT MODE

The 33982 indicates the following faults as they occur by driving the  $\overline{FS}$  pin to logic [0]:

- Overtemperature fault
- Overvoltage and undervoltage fault
- Open load fault
- Overcurrent fault (high and low)

The  $\overline{FS}$  pin automatically returns to logic [1] when the fault condition is removed, except for overcurrent and in some cases undervoltage. Fault information is retained in the fault register and is available (and reset) via the SO pin during the first valid SPI communication (refer to [Table 17](#)).

### *Protection and diagnostic features*

#### OVERTEMPERATURE FAULT (NON-LATCHING)

The 33982 incorporates overtemperature detection and shutdown circuitry in the output structure. Overtemperature detection is enabled when the output is in the ON state.

For the output, an overtemperature fault (OTF) condition results in the faulted output turning OFF until the temperature falls below the T<sub>SD(HYS)</sub>. This cycle continues indefinitely until action is taken by the MCU to shut OFF the output, or until the offending load is removed. When experiencing this fault, the OTF fault bit is set in the status register and cleared after either a valid SPI read or a power reset of the device.

#### OVERVOLTAGE FAULT (NON-LATCHING)

The 33982 shuts down the output during an overvoltage fault (OVF) condition on the VPWR pin. The output remains in the OFF state until the overvoltage condition is removed. When experiencing this fault, the OVF fault bit is set in bit OD1 and cleared after either a valid SPI read or a power reset of the device. The overvoltage protection and diagnostic can be disabled through the SPI (bit OV\_dis).

#### UNDERVOLTAGE SHUTDOWN (LATCHING OR NON-LATCHING)

The output(s) latches off at some battery voltage below 6.0 V. As long as the V<sub>DD</sub> level stays within the normal specified range, the internal logic states within the device is sustained.

In cases where the battery voltage drops below the undervoltage threshold, (VPWRUV) the output turns off,  $\overline{FS}$  goes to logic [0], and the fault register UVF bit is set to 1.

Two cases need to be considered when the battery level recovers:

- If the output(s) command is (are) low,  $\overline{FS}$  goes to logic [1], but the UVF bit remains set to 1 until the next read operation.
- If the output command is ON, then  $\overline{FS}$  remains at logic [0]. The output must be turned OFF and ON again to re-enable the state of output and release  $\overline{FS}$ . The UVF bit remains set to 1 until the next read operation.

The undervoltage protection can be disabled through the SPI (bit UV\_dis = 1). In this case, the  $\overline{FS}$  and UVF bits do not report any undervoltage fault condition and the output state is not changed as long as the battery voltage does not drop any lower than 2.5 V.

#### OPEN LOAD FAULT (NON-LATCHING)

The 33982 incorporates open load detection circuitry on the output. Output open load fault (OLF) is detected and reported as a fault condition when the output is disabled (OFF). The open load fault is detected and latched into the status register after the internal gate voltage is pulled low enough to turn OFF the output. The OLF fault bit is set in the status register. If the open load fault is removed, the status register is cleared after reading the register.

The open load protection can be disabled through the SPI (bit OL\_dis). It is recommended to disable the open load detection circuitry: (OL\_dis bit sets to logic [1]) in case of a permanent open load fault condition.

#### OVERCURRENT FAULT (LATCHING)

The 33982 has eight programmable overcurrent low detection levels (I<sub>OCL</sub>) and two programmable overcurrent high detection levels (I<sub>OCH</sub>) for maximum device protection. The two selectable, simultaneously active overcurrent detection levels, defined by I<sub>OCH</sub> and I<sub>OCL</sub>, are illustrated in [Figure 6](#). The eight different overcurrent low detection levels (I<sub>OCL0</sub>:I<sub>OCL7</sub>) are likewise illustrated in [Figure 6](#).

If the load current level ever reaches the selected overcurrent low detection level and the overcurrent condition exceeds the programmed overcurrent time period ( $t_{OCX}$ ), the device latches the output OFF.

If at any time the current reaches the selected  $I_{OCH}$  level, then the device immediately latches the fault and turn OFF the output, regardless of the selected  $t_{OCL}$  driver. For both cases, the device output stays off indefinitely until the device is commanded OFF and then ON again.

**Table 8. Device behavior in case of undervoltage**

High-side Switch (VPWR Battery Voltage)**	State	UV Enable IN = 0 (Falling VPWR)	UV Enable IN = 0 (Rising VPWR)	UV Enable IN*** = 1 (Falling VPWR)	UV Enable IN*** = 1 (Rising VPWR)	UV Disable IN = 0 (Falling or Rising VPWR)	UV Disable IN*** = 1 (Falling or Rising VPWR)
VPWR > VPWRUV	Output State	OFF	OFF	ON	OFF	OFF	ON
	$\overline{FS}$ State	1	1	1	0	1	1
	SPI Fault Register UVF Bit	0	1 until next read	0	1	0	0
VPWRUV > VPWR > UVPOR	Output State	OFF	OFF	OFF	OFF	OFF	ON
	$\overline{FS}$ State	0	0	0	0	1	1
	SPI Fault Register UVF Bit	1	1	1	1	0	0
UVPOR > VPWR > 2.5 V*	Output State	OFF	OFF	OFF	OFF	OFF	ON
	$\overline{FS}$ State	1	1	1	1	1	1
	SPI Fault Register UVF Bit	1 until next read	1	1 until next read	1 until next read	0	0
2.5 V > VPWR > 0 V	Output State	OFF	OFF	OFF	OFF	OFF	OFF
	$\overline{FS}$ State	1	1	1	1	1	1
	SPI Fault Register UVF Bit	1 until next read	1 until next read	1 until next read	1 until next read	0	0
	Comments	UV fault is not latched	UV fault is not latched		UV fault is latched		

\* Typical value; not guaranteed

\*\* While  $V_{DD}$  remains within specified range.

\*\*\* = IN is equivalent to IN direct input or IN\_spi SPI input.

## REVERSE BATTERY

The output survives the application of reverse voltage as low as -16 V. Under these conditions, the output's gate is enhanced to keep the junction temperature less than 150 °C. The ON resistance of the output is fairly similar to that in the Normal mode. No additional passive components are required.

## GROUND DISCONNECT PROTECTION

In the event the 33982 ground is disconnected from load ground, the device protects itself and safely turns OFF the output regardless the state of the output at the time of disconnection. A 10 k $\Omega$  resistor needs to be added between the WAKE pin and the rest of the circuitry in order to ensure that the device turns off in case of a ground disconnect and to prevent this pin to exceed its maximum ratings.

## Functional device operation

### Logic commands and registers

#### SPI PROTOCOL DESCRIPTION

The SPI interface has a full duplex, three-wire synchronous data transfer with four I/O lines associated with it: Serial Clock (SCLK), Serial Input (SI), Serial Output (SO), and Chip Select ( $\overline{CS}$ ).

The SI/SO pins of the 33982 follow a first-in first-out (D7/D0) protocol with both input and output words transferring the most significant bit (MSB) first. All inputs are compatible with 5.0 V CMOS logic levels. The SPI lines perform the following functions:

#### SERIAL CLOCK (SCLK)

The SCLK pin clocks the internal shift registers of the 33982 device. The serial input pin (SI) accepts data into the input shift register on the falling edge of the SCLK signal while the serial output pin (SO) shifts data information out of the SO line driver on the rising edge of the SCLK signal. It is important that the SCLK pin be in a logic LOW state whenever  $\overline{CS}$  makes any transition. For this reason, it is recommended that the SCLK pin be in a logic [0] state whenever the device is not accessed ( $\overline{CS}$  logic [1] state). SCLK has an active internal pull-down,  $I_{DWN}$ . When  $\overline{CS}$  is logic [1], signals at the SCLK and SI pins are ignored and SO is tri-stated (high-impedance). (See [Figure 10](#) and [Figure 11](#).)

#### SERIAL INTERFACE (SI)

This is a serial interface (SI) command data input pin. SI instruction is read on the falling edge of SCLK. An 8-bit stream of serial data is required on the SI pin, starting with D7 to D0. The internal registers of the 33982 are configured and controlled using a 4-bit addressing scheme, as shown in [Table 9](#). Register addressing and configuration are described in [Table 10](#). The SI input has an active internal pull-down,  $I_{DWN}$ .

#### SERIAL OUTPUT (SO)

The SO pin is a tri-stateable output from the shift register. The SO pin remains in a high-impedance state until the  $\overline{CS}$  pin is put into a logic [0] state. The SO data is capable of reporting the status of the output, the device configuration, and the state of the key inputs. The SO pin changes states on the rising edge of SCLK and reads out on the falling edge of SCLK. Fault and input status descriptions are provided in [Table 16](#).

#### CHIP SELECT ( $\overline{CS}$ )

The  $\overline{CS}$  pin enables communication with the master microcontroller (MCU). When this pin is in a logic [0] state, the device is capable of transferring information to and receiving information from the MCU. The 33982 latches in data from the input shift registers to the addressed registers on the rising edge of  $\overline{CS}$ . The device transfers status information from the power output to the shift register on the falling edge of  $\overline{CS}$ . The SO output driver is enabled when  $\overline{CS}$  is logic [0].  $\overline{CS}$  should transition from a logic [1] to a logic [0] state only when SCLK is a logic [0].  $\overline{CS}$  has an active internal pull-up,  $I_{UP}$ .

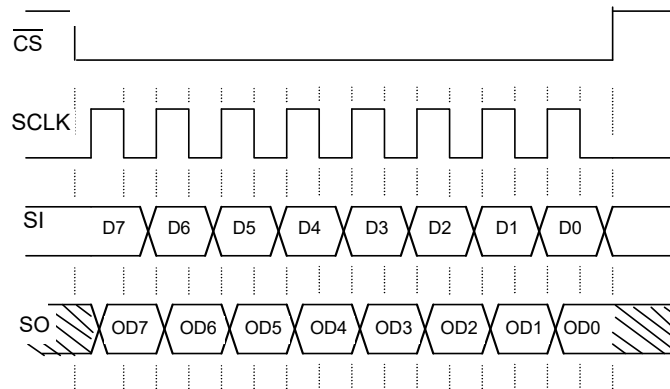

- Notes
1.  $\overline{RST}$  is a logic [1] state during the above operation.
  2. D7:D0 relate to the most recent ordered entry of data into the device.
  3. OD7:OD0 relate to the first 8 bits of ordered fault and status data out of the device.

Figure 10. Single 8-bit word SPI communication

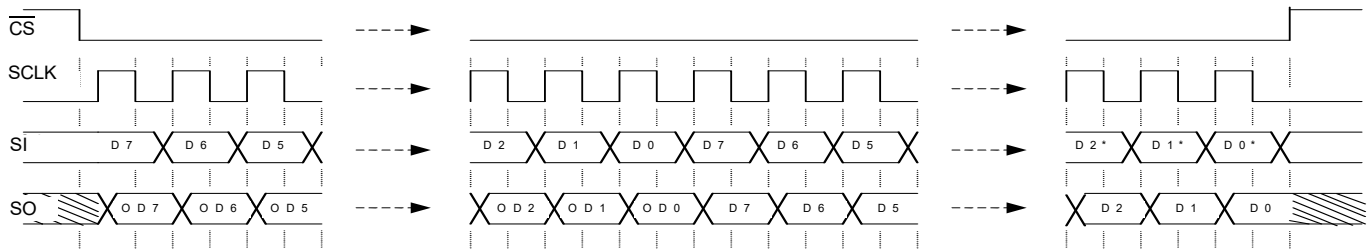

- Notes
1.  $\overline{RST}$  is a logic [1] state during the above operation.
  2. D7:D0 relate to the most recent ordered entry of data into the device.
  3. D7\*:D0\* relate to the previous 8 bits (last command word) of data that was previously shifted into the device.
  4. OD7:OD0 relate to the first 8 bits of ordered fault and status data out of the device.

Figure 11. Multiple 8-bit word SPI communication

**SERIAL INPUT COMMUNICATION**

SPI communication is accomplished using 8-bit messages. A message is transmitted by the MCU starting with the MSB, D7, and ending with the LSB, D0 (Table 9). Each incoming command message on the SI pin can be interpreted using the following bit assignments: the MSB (D7) is the watchdog bit and in some cases a register address bit; the next three bits, D6:D4, are used to select the command register; and the remaining four bits, D3:D0, are used to configure and control the output and its protection features.

Multiple messages can be transmitted in succession to accommodate those applications where daisy chaining is desirable or to confirm transmitted data as long as the messages are all multiples of eight bits. Any attempt made to latch in a message that is not eight bits are ignored. The 33982 has defined registers, which are used to configure the device and to control the state of the output. Table 10, summarizes the SI registers. The registers are addressed via D6:D4 of the incoming SPI word (Table 9).

Table 9. SI message bit assignment

Bit Sig	SI Msg Bit	Message Bit Description
MSB	D7	Watchdog in: toggled to satisfy watchdog requirements; also used as a register address bit.
	D6:D4	Register address bits.
	D3:D1	Used to configure the inputs, outputs, and the device protection features and SO status content.
LSB	D0	Used to configure the inputs, outputs, and the device protection features and SO status content.

Table 10. Serial input address and configuration bit map

SI Register	Serial Input Data							
	D7	D6	D5	D4	D3	D2	D1	D0
STATR	x	0	0	0	0	SOA2	SOA1	SOA0
OCR	x	0	0	1	0	0	CSNS $\overline{EN}$	IN_SPI
SOCHLR	x	0	1	0	SOCH	SOCL2	SOCL1	SOCL0
CDTOLR	x	0	1	1	OL_dis	CD_dis	OCLT1	OCLT0
DICR	x	1	0	0	FAST SR	CSNS high	IN dis	A/O
OSDR	0	1	0	1	0	OSD2	OSD1	OSD0
WDR	1	1	0	1	0	0	WD1	WD0
NAR	0	1	1	0	0	0	0	0
UOVR	1	1	1	0	0	0	UV_dis	OV_dis
TEST	x	1	1	1	NXP Internal Use (Test)			

x = Don't care.

## DEVICE REGISTER ADDRESSING

The following section describes the possible register addresses and their impact on device operation.

### Address x000—Status Register (STATR)

The STATR register is used to read the device status and the various configuration register contents without disrupting the device operation or the register contents. The register bits D2, D1, and D0 determine the content of the first eight bits of SO data. In addition to the device status, this feature provides the ability to read the content of the OCR, SOCHLR, CDTOLR, DICR, OSDR, WDR, NAR, and UOVR registers. (Refer to the section entitled [Serial Output Communication \(Device Status Return Data\)](#) beginning on page [27](#).)

### Address x001—Output Control Register (OCR)

The OCR register allows the MCU to control the output through the SPI. Incoming message bit D0 (IN\_SPI) reflects the desired states of the high-side output: a logic [1] enables the output switch and a logic [0] turns it OFF. A logic [1] on message bit D1 enables the Current Sense (CSNS) pin. Bits D2 and D3 must be logic [0]. Bit D7 is used to feed the watchdog if enabled.

### Address x010—Select Overcurrent High and Low Register (SOCHLR)

The SOCHLR register allows the MCU to configure the output overcurrent low and high detection levels, respectively. In addition to protecting the device, this slow blow fuse emulation feature can be used to optimize the load requirements to match system characteristics. Bits D2:D0 are used to set the overcurrent low detection level to one of eight possible levels as defined in [Table 11](#). Bit D3 is used to set the overcurrent high detection level to one of two levels as defined in [Table 12](#).

**Table 11. Overcurrent low detection levels**

SOCL2 (D2)	SOCL1 (D1)	SOCL0 (D0)	Overcurrent Low Detection (Amperes)
0	0	0	50
0	0	1	45
0	1	0	40
0	1	1	35
1	0	0	30
1	0	1	25
1	1	0	20
1	1	1	15

**Table 12. Overcurrent high detection levels**

SOCH (D3)	Overcurrent High Detection (Amperes)
0	150
1	100

### Address x011—Current Detection Time and Open Load Register (CDTOLR)

The CDTOLR register is used by the MCU to determine the amount of time the device allows an overcurrent low condition before output latches OFF occurs. Bits D1 and D0 allow the MCU to select one of four fault blanking times defined in [Table 13](#). Note that these timeouts apply only to the overcurrent low detection levels. If the selected overcurrent high level is reached, the device latches off within 20  $\mu$ s.

**Table 13. Overcurrent Low Detection Blanking Time**

OCLT[1:0]	Timing
00	155 ms
01	10 ms
10	1.2 ms
11	150 $\mu$ s

A logic [1] on bit D2 disables the overcurrent low (CD\_dis) detection timeout feature. A logic [1] on bit D3 disables the open load (OL) detection feature.

**Address x100—Direct Input Control Register (DICR)**

The DICR register is used by the MCU to enable, disable, or configure the direct IN pin control of the output. A logic [0] on bit D1 enables the output for direct control by the IN pin. A logic [1] on bit D1 disables the output from direct control. While addressing this register, if the input was enabled for direct control, a logic [1] for the D0 bit results in a Boolean AND of the IN pin with its corresponding D0 message bit when addressing the OCR register. Similarly, a logic [0] on the D0 pin results in a Boolean OR of the IN pin with the corresponding message bits when addressing the OCR register.

The DICR register is useful if there is a need to independently turn on and off several loads that are PWMed at the same frequency and duty cycle with only one PWM signal. This type of operation can be accomplished by connecting the pertinent direct IN pins of several devices to a PWM output port from the MCU, and configuring each of the outputs to be controlled via their respective direct IN pin. The DICR is then used to Boolean AND the direct IN(s) of each of the outputs with the dedicated SPI bit that also controls the output. Each configured SPI bit can now be used to enable and disable the common PWM signal from controlling its assigned output.

A logic [1] on bit D2 is used to select the high ratio ( $C_{SR1}$ , 1/40000) on the CSNS pin. The default value [0] is used to select the low ratio ( $C_{SR0}$ , 1/5400). A logic [1] on bit D3 is used to select the high-speed slew rate. The default value [0] corresponds to the low-speed slew rate.

**Address 0101—Output Switching Delay Register (OSDR)**

The OSDR register is used to configure the device with a programmable time delay that is active during Output On transitions that are initiated via the SPI (not via direct input). Whenever the input is commanded to transition from logic [0] to logic [1], the output are held OFF for the time delay configured in the OSDR register.

The programming of the contents of this register has no effect on device Fail-safe mode operation. The default value of the OSDR register is 000, equating to no delay, since the switching delay time is 0 ms. This feature allows the user a way to minimize inrush currents, or surges, thereby allowing loads to be synchronously switched ON with a single command. [Table 14](#) shows the eight selectable output switching delay times, which range from 0 ms to 525 ms.

**Table 14. Switching delay**

OSD[2:0] (D2:D0)	Turn ON Delay (ms)
000	0
001	75
010	150
011	225
100	300
101	375
110	450
111	525

**Address 1101—Watchdog Register (WDR)**

The WDR register is used by the MCU to configure the watchdog timeout. Watchdog timeout is configured using bits D1 and D0 ([Table 15](#)). When bits D1 and D0 are programmed for the desired watchdog timeout period, the WD bit (D7) should be toggled as well to ensure that the new timeout period is programmed at the beginning of a new count sequence.

**Table 15. Watchdog timeout**

WD[1:0] (D1:D0)	Timing (ms)
00	620
01	310
10	2500
11	1250

**Address 0110—No Action Register (NAR)**

The NAR register can be used to no-operation fill SPI data packets in a daisy chain SPI configuration. This allows devices to not be affected by commands being clocked over a daisy-chained SPI configuration, and by toggling the WD bit (D7) the watchdog circuitry continues to be reset while no programming or data readback functions are being requested from the device.

### Address 1110—Undervoltage/Overvoltage Register (UOVR)

The UOVR register can be used to disable or enable the overvoltage and/or undervoltage protection. By default ([0]), both protections are active. When disabled, an undervoltage or overvoltage condition fault is not reported in bits D1 and D0 of the output fault register.

### Address x111—TEST

The TEST register is reserved for test and is not accessible with SPI during normal operation.

### SERIAL OUTPUT COMMUNICATION (DEVICE STATUS RETURN DATA)

When the  $\overline{CS}$  pin is pulled low, the output status register is loaded. Meanwhile, the data is clocked out MSB- (OD7-) first as the new message data is clocked into the SI pin. The first eight bits of data clocking out of the SO, and following a  $\overline{CS}$  transition, are dependant upon the previously written SPI word.

Any bits clocked out of the SO pin after the first eight are representative of the initial message bits clocked into the SI pin since the  $\overline{CS}$  pin first transitioned to a logic [0]. This feature is useful for daisy chaining devices as well as message verification.

A valid message length is determined following a  $\overline{CS}$  transition of logic [0] to logic [1]. If there is a valid message length, the data is latched into the appropriate registers. A valid message length is a multiple of eight bits. At this time, the SO pin is tri-stated and the fault status register is now able to accept new fault status information.

The output status register correctly reflects the status of the STATR-selected register data at the time the  $\overline{CS}$  is pulled to a logic [0] during SPI communication and/or for the period of time since the last valid SPI communication, with the following exceptions:

- The previous SPI communication was determined to be invalid. In this case, the status reports as though the invalid SPI communication never occurred.
- Battery transients below 6.0 V resulting in an undervoltage shutdown of the outputs may result in incorrect data loaded into the status register. The SO data transmitted to the MCU during the first SPI communication following an undervoltage  $V_{PWR}$  condition should be ignored.
- The  $\overline{RST}$  pin transition from a logic [0] to logic [1] while the WAKE pin is at logic [0] may result in incorrect data loaded into the status register. The SO data transmitted to the MCU during the first SPI communication following this condition should be ignored.

**Table 16. Serial output bit map descriptions**

Previous STATR D7, D2, D1, D0				Serial Output Returned Data							
SOA3	SOA2	SOA1	SOA0	OD7	OD6	OD5	OD4	OD3	OD2	OD1	OD0
x	0	0	0	WDin	OTF	OCHF	OCLF	OLF	UVF	OVF	FAULT
x	0	0	1	WDin	0	0	1	0	0	CSNS $\overline{EN}$	IN_SPI
x	0	1	0	WDin	0	1	0	SOCH	SOCL2	SOCL1	SOCL0
x	0	1	1	WDin	0	1	1	OL_dis	CD_dis	OCLT1	OCLT0
x	1	0	0	WDin	1	0	0	Fast SR	CSNS High	IN dis	A/O
0	1	0	1	0	1	0	1	FSM_HS	OSD2	OSD1	OSD0
1	1	0	1	1	1	0	1	0	WDTO	WD1	WD0
0	1	1	0	0	1	1	0	0	IN Pin	FSI Pin	WAKE Pin
1	1	1	0	1	1	1	0	0	1110	UV_dis	OV_dis
x	1	1	1	WDin	–	–	–	See <a href="#">Table 2</a>	–	–	–

x = Don't care.

### SERIAL OUTPUT BIT ASSIGNMENT

The eight bits of serial output data depend on the previous serial input message, as explained in the following paragraphs. [Table 16](#) summarizes the SO register content.

Bit OD7 reflects the state of the watchdog bit (D7) addressed during the prior communication. The contents of bits OD6:OD0 depend upon the bits D2:D0 from the most recent STATR command SOA2:SOA0.

#### Previous Address SOA[2:0]=000

If the previous three MSBs are 000, bits OD6:OD0 reflect the current state of the Fault register (FLTR) ([Table 17](#)).

**Previous Address SOA[2:0]=001**

The data in bits OD1 and OD0 contain CSNS  $\overline{EN}$  and IN\_SPI programmed bits, respectively.

**Previous Address SOA[2:0]=010**

The data in bit OD3 contain the programmed overcurrent high detection level (refer to [Table 12](#)), and the data in bits OD2, OD1, and OD0 contain the programmed overcurrent low detection levels (refer to [Table 11](#)).

**Table 17. Fault register**

OD7	OD6	OD5	OD4	OD3	OD2	OD1	OD0
x	OTF	OCHF	OCLF	OLF	UVF	OVF	FAULT

OD7 (x) = Don't care.

OD6 (OTF) = Overtemperature Flag.

OD5 (OCHF) = Overcurrent High Flag. (This fault is latched.)

OD4 (OCLF) = Overcurrent Low Flag. (This fault is latched.)

OD3 (OLF) = Open Load Flag.

OD2 (UVF) = Undervoltage Flag. (This fault is latched or not latched.)

OD1 (OVF) = Overvoltage Flag.

OD0 (FAULT) = This flag reports a fault and is reset by a read operation.

**Note** The  $\overline{FS}$  pin reports a fault and is reset by a new Switch-ON command (via SPI or direct input IN).

**Previous Address SOA[2:0]=011**

The data returned in bits OD1 and OD0 are current values for the overcurrent fault blanking time, illustrated in [Table 13](#). Bit OD2 reports when the overcurrent detection timeout feature is active. OD3 reports whether the open load circuitry is active.

**Previous Address SOA[2:0]=100**

The returned data contain the programmed values in the DICR.

**Previous Address SOA[2:0]=101**

- SOA3 = 0. The returned data contain the programmed values in the OSDR. Bit OD3 (FSM\_HS) reflects the state of the output in the Fail-safe mode after a watchdog timeout occurs.
- SOA3 = 1. The returned data contain the programmed values in the WDR. Bit OD2 (WDTO) reflects the status of the watchdog circuitry. If WDTO bit is logic [1], the watchdog has timed out and the device is in Fail-safe mode. If WDTO is logic [0], the device is in Normal mode (assuming device is powered and not in the Sleep mode), with the watchdog either enabled or disabled.

**Previous Address SOA[2:0]=110**

- SOA3 = 0. OD2, OD1, and OD0 return the state of the IN, FSI, and WAKE pins, respectively ([Table 18](#)).

**Table 18. Pin register**

OD2	OD1	OD0
IN Pin	FSI Pin	WAKE Pin

- SOA3 = 1. The returned data contains the programmed values in the UOVR register. Bit OD1 reflects the state of the undervoltage protection, while bit OD0 reflects the state of the overvoltage protection (refer to [Table 16](#)).

**Previous Address SOA[2:0]=111**

Null Data. No previous register Read Back command received, so bits OD2, OD1, and OD0 are null, or 000.

## Typical applications

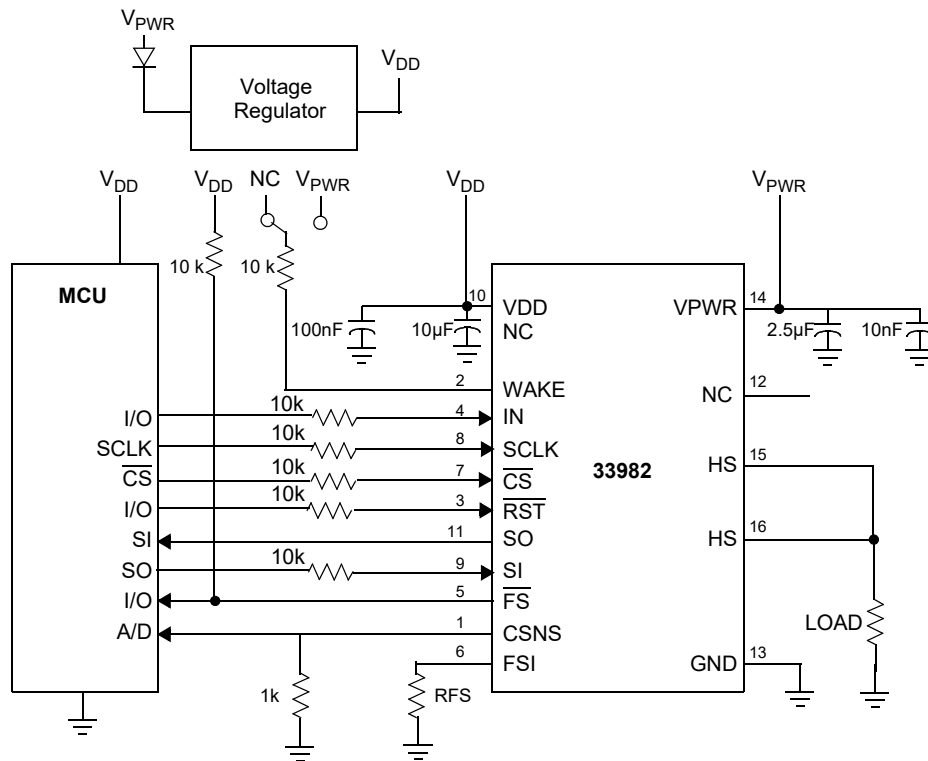

**Figure 12. Typical applications**

The loads must be chosen in order to guarantee the device normal operating condition for junction temperatures from -40 °C to 150 °C. In case of permanent short-circuit conditions, the duration and number of activation cycles must be limited with a dedicated MCU fault management, using the fault reporting through the SPI. When driving DC motor or Solenoid loads demanding multiple switching, an external recirculation device must be used to maintain the device in its safe operating area.

Two application notes are available:

- AN3274, which proposes safe configurations of the eXtreme switch devices in case of application faults, and to protect all circuitry with minimum external components.
- AN2469, which provides guidelines for printed circuit board (PCB) design and assembly.

Development effort is required by the end users to optimize the board design and PCB layout, in order to reach electromagnetic compatibility standards (emission and immunity).

## Packaging

### *Soldering information*

#### **SOLDERING INFORMATION**

The 33982 is packaged in a surface mount power package (PQFN), intended to be soldered directly on the printed circuit board. The [AN2467](#) provides guidelines for Printed Circuit Board design and assembly.

### *Package dimensions*

For the most current revision of the package, visit [www.nxp.com](http://www.nxp.com) and perform a keyword search on 98ARL10596D and 98ASA00815D. Dimensions shown are provided for reference ONLY.

**Table 19.**

Suffix	Package outline drawing number
CHFK	98ARL10521D
EHFK	98ASA00815D

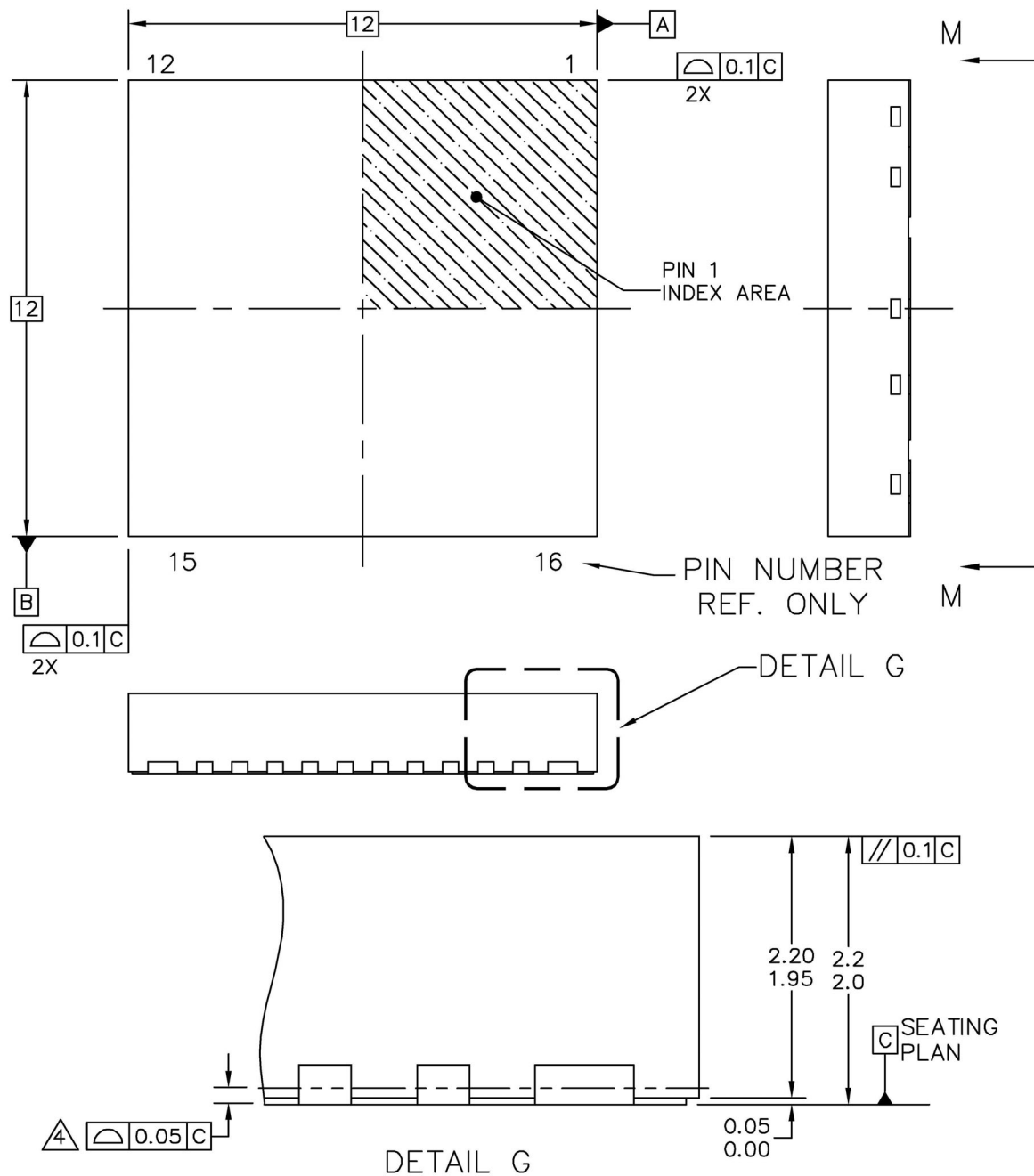

© FREESCALE SEMICONDUCTOR, INC. ALL RIGHTS RESERVED.	<b>MECHANICAL OUTLINE</b>	PRINT VERSION NOT TO SCALE	
TITLE: POWER QUAD FLAT NON-LEADED PACKAGE (PWR QFN) 16 TERMINAL, 0.9 PITCH(12X12X2.1)	DOCUMENT NO: 98ARL10521D	REV: D	
	CASE NUMBER: 1402-03	21 SEP 2011	
	STANDARD: NON-JEDEC		

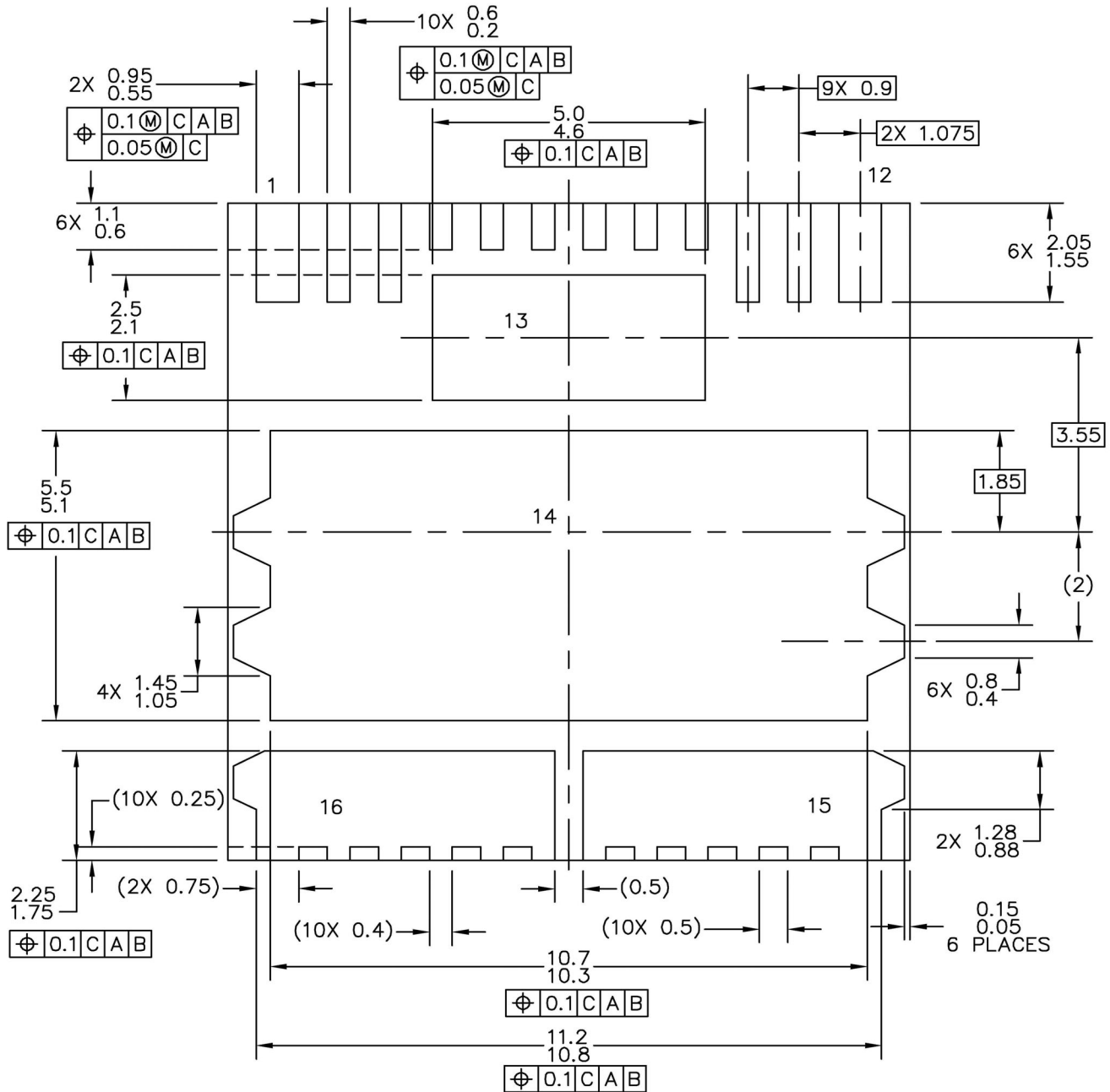

VIEW M-M

© FREESCALE SEMICONDUCTOR, INC. ALL RIGHTS RESERVED.	<b>MECHANICAL OUTLINE</b>	PRINT VERSION NOT TO SCALE
TITLE: POWER QUAD FLAT NON-LEADED PACKAGE (PWR QFN) 16 TERMINAL, 0.9 PITCH(12X12X2.1)	DOCUMENT NO: 98ARL10521D	REV: D
	CASE NUMBER: 1402-03	21 SEP 2011
STANDARD: NON-JEDEC		

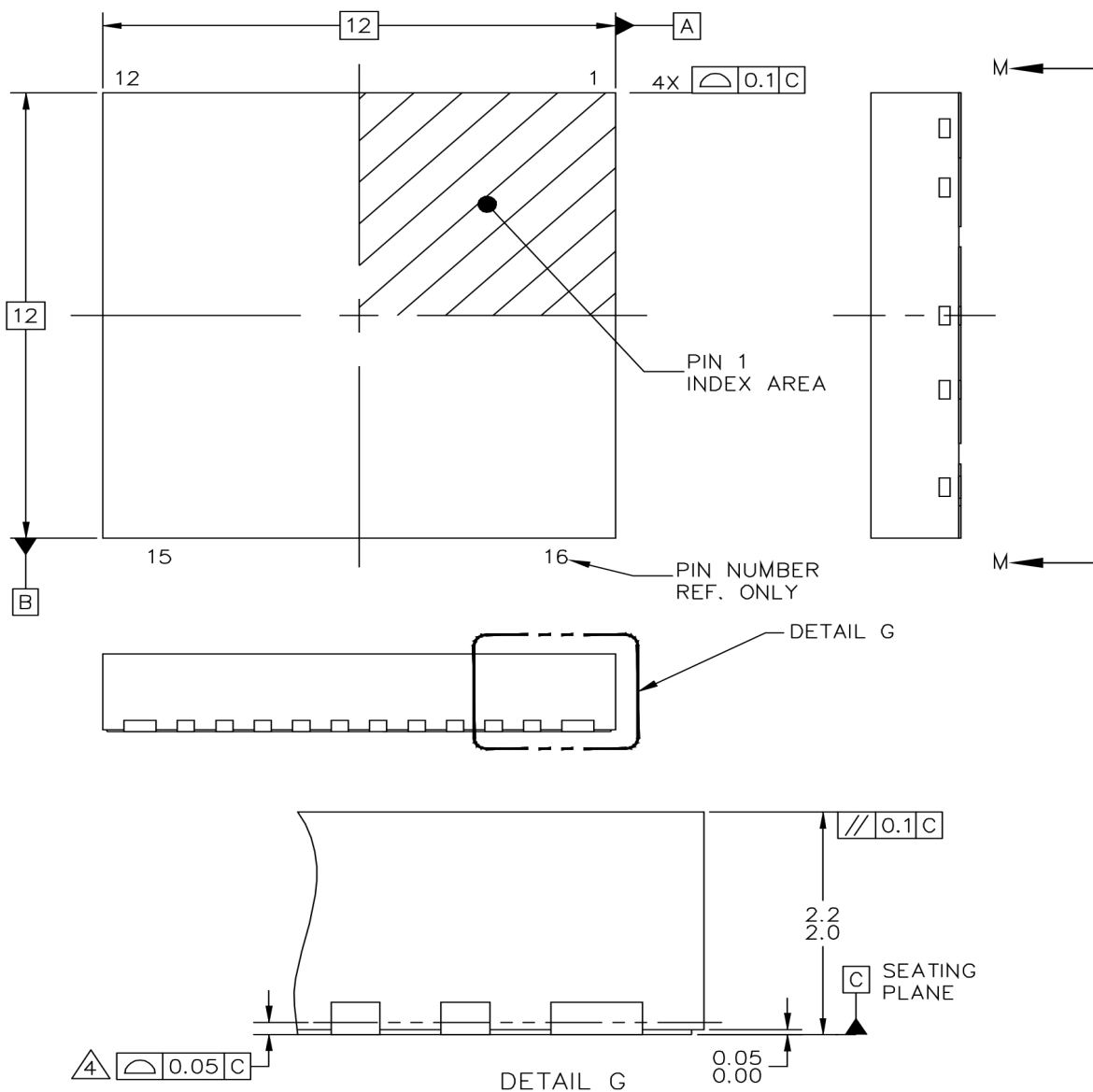

© NXP SEMICONDUCTORS N.V. ALL RIGHTS RESERVED	MECHANICAL OUTLINE	PRINT VERSION NOT TO SCALE	
TITLE: PQFN, 12 X 12 X 2.1 PKG, 0.9 PITCH, 16 TERMINAL		DOCUMENT NO: 98ASAO0815D	REV: B
		STANDARD: NON-JEDEC	
		SOT1630-2	22 MAY 2018

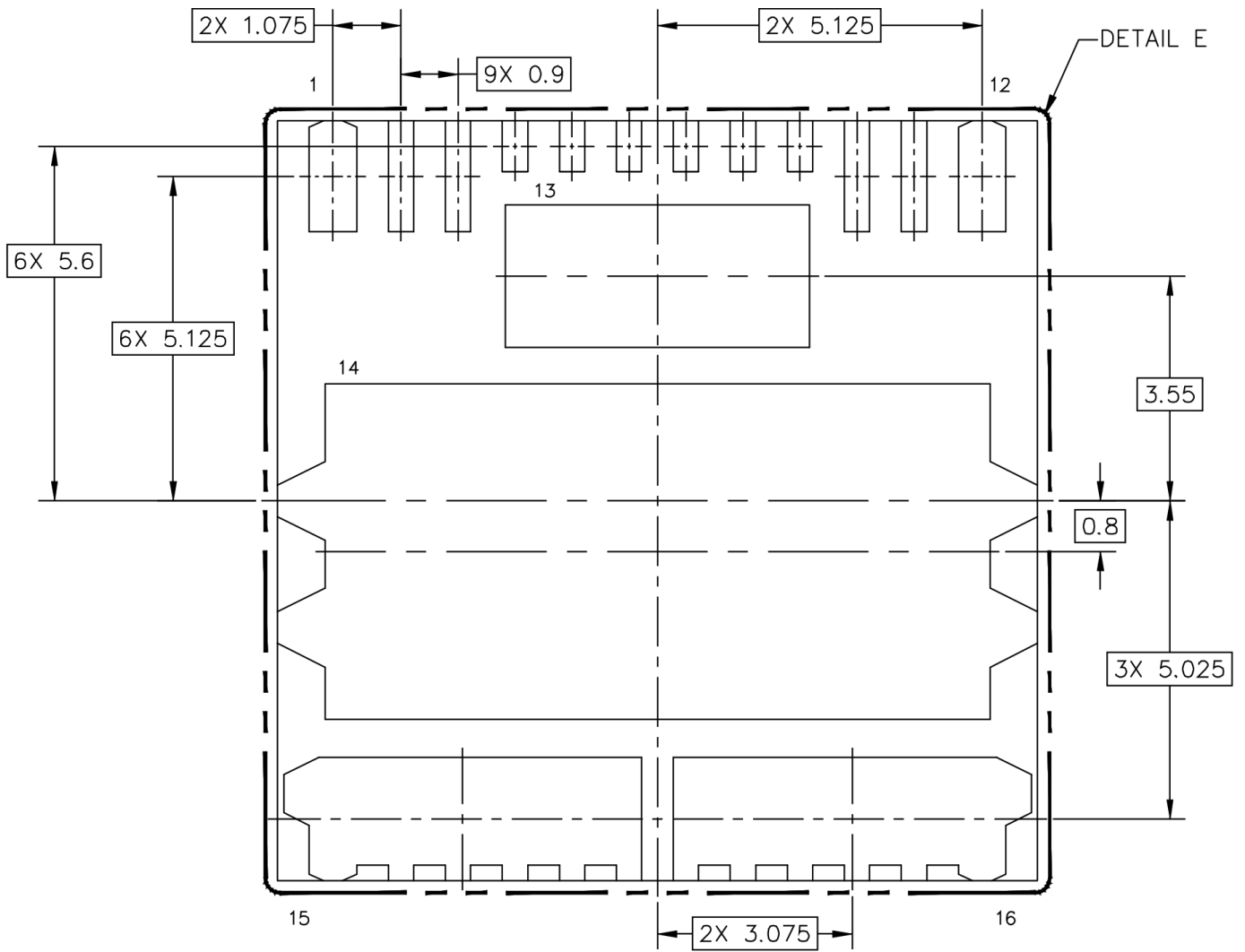

VIEW M-M

© NXP SEMICONDUCTORS N.V. ALL RIGHTS RESERVED	MECHANICAL OUTLINE	PRINT VERSION NOT TO SCALE	
TITLE: PQFN, 12 X 12 X 2.1 PKG, 0.9 PITCH, 16 TERMINAL		DOCUMENT NO: 98ASA00815D	REV: B
		STANDARD: NON-JEDEC	
		SOT1630-2	22 MAY 2018

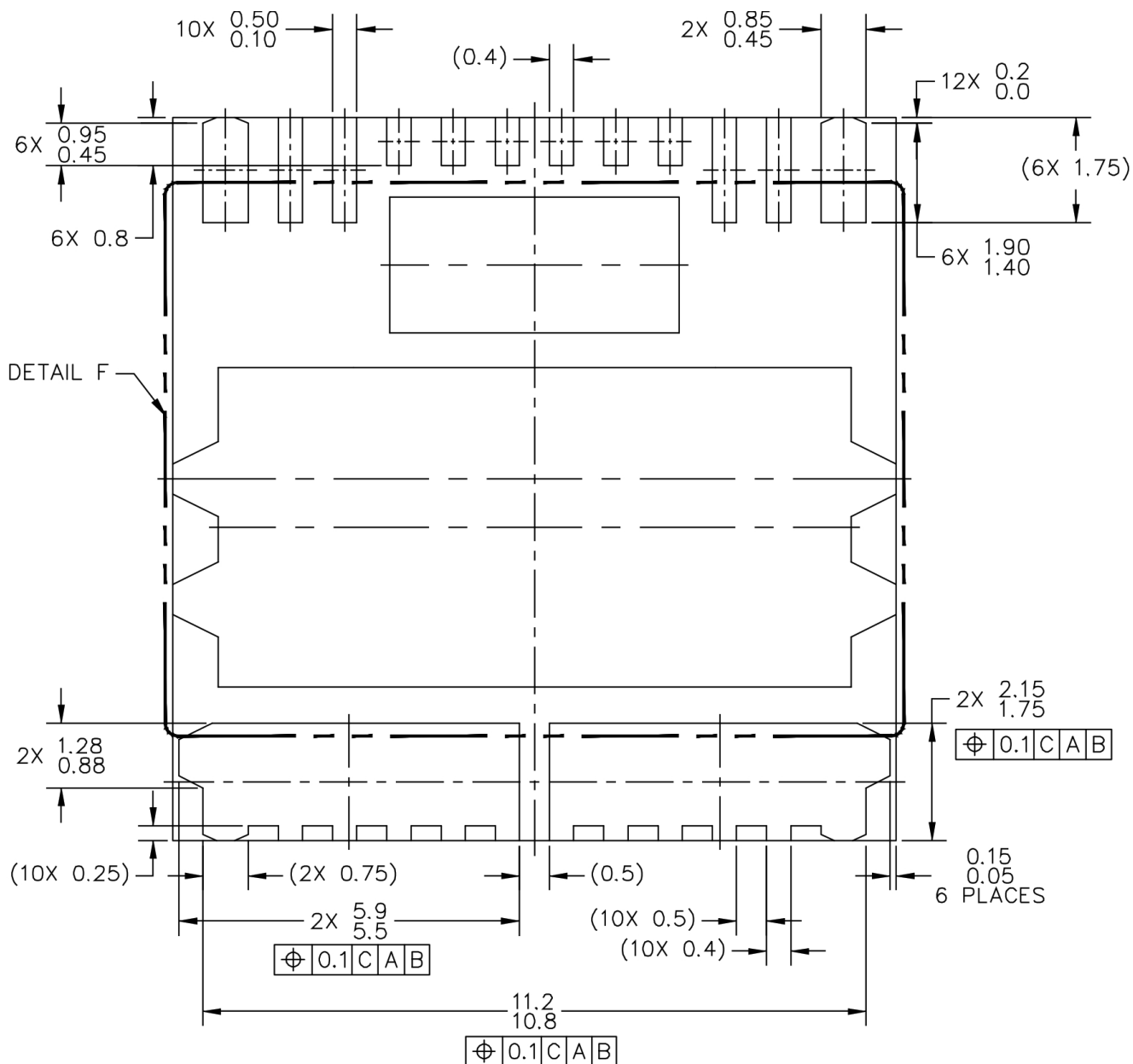

UNLESS OTHERWISE SPECIFIED  
 POSITIONAL TOLERANCE FOR  
 ALL LEADS SHALL BE AS FOLLOWS

⊕	0.1	M	C	A	B
	0.05	M	C		

DETAIL E

© NXP SEMICONDUCTORS N.V. ALL RIGHTS RESERVED	MECHANICAL OUTLINE	PRINT VERSION NOT TO SCALE
TITLE: PQFN, 12 X 12 X 2.1 PKG, 0.9 PITCH, 16 TERMINAL	DOCUMENT NO: 98ASA00815D	REV: B
	STANDARD: NON-JEDEC	
	SOT1630-2	22 MAY 2018

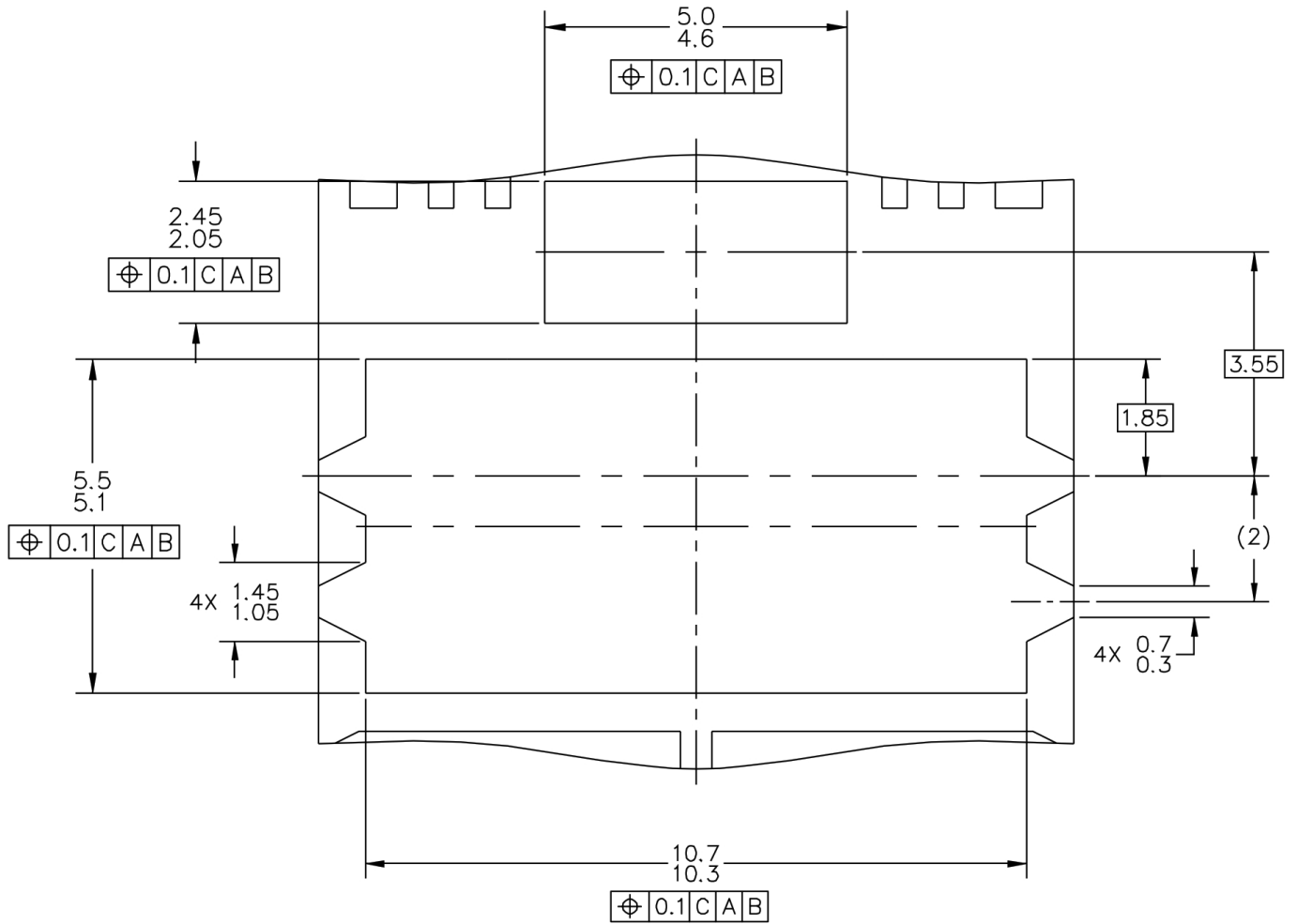

DETAIL F

© NXP SEMICONDUCTORS N.V. ALL RIGHTS RESERVED	MECHANICAL OUTLINE	PRINT VERSION NOT TO SCALE
TITLE: PQFN, 12 X 12 X 2.1 PKG, 0.9 PITCH, 16 TERMINAL	DOCUMENT NO: 98ASA00815D	REV: B
	STANDARD: NON-JEDEC	
	SOT1630-2	22 MAY 2018

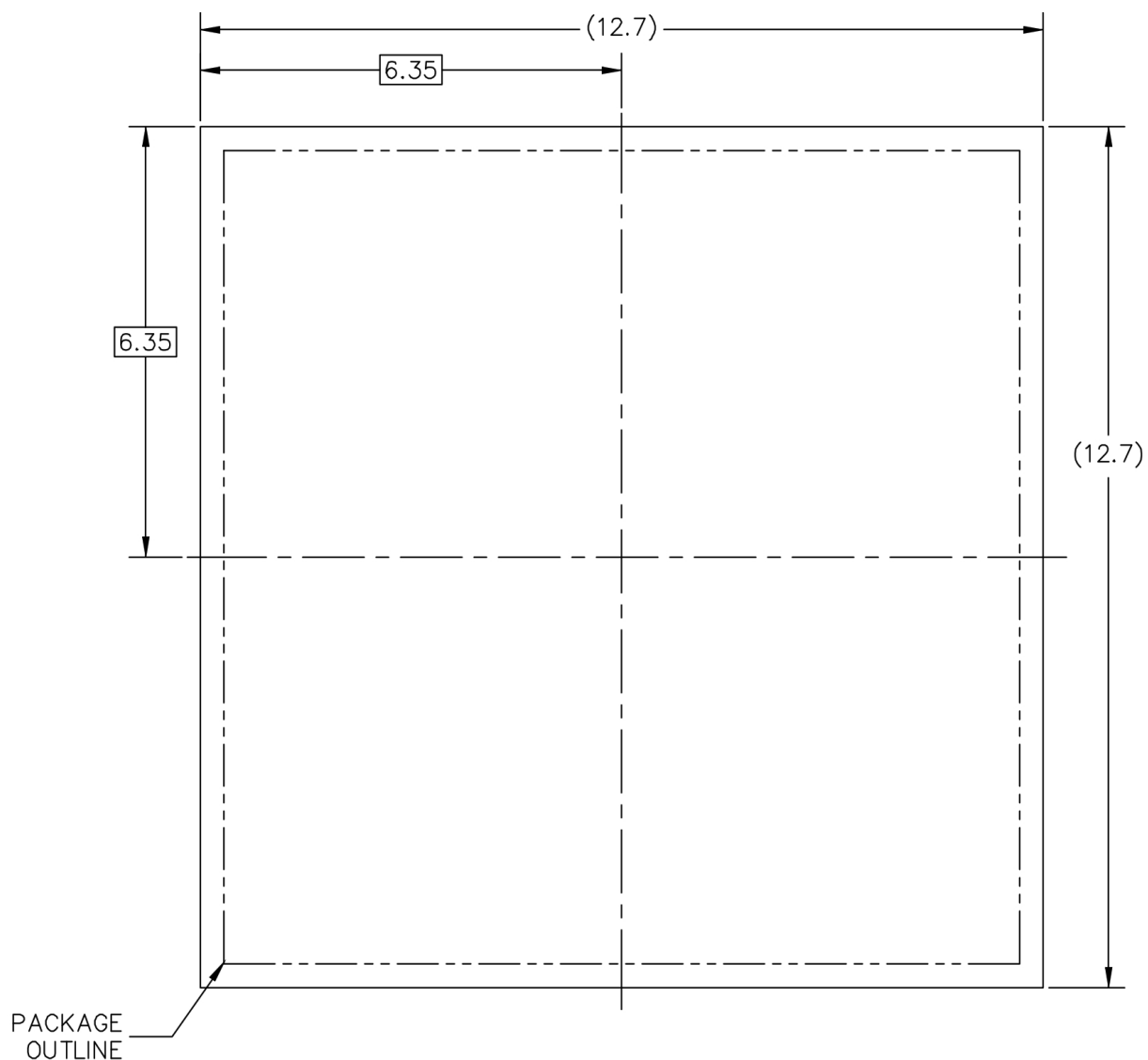

PCB DESIGN GUIDELINES – SOLDER MASK OPENING PATTERN 1

THIS SHEET SERVES ONLY AS A GUIDELINE TO HELP DEVELOP A USER SPECIFIC SOLUTION. DEVELOPMENT EFFORT WILL STILL BE REQUIRED BY END USERS TO OPTIMIZE PCB MOUNTING PROCESSES AND BOARD DESIGN IN ORDER TO MEET INDIVIDUAL / SPECIFIC REQUIREMENTS.

© NXP SEMICONDUCTORS N.V. ALL RIGHTS RESERVED	MECHANICAL OUTLINE	PRINT VERSION NOT TO SCALE	
TITLE: PQFN, 12 X 12 X 2.1 PKG, 0.9 PITCH, 16 TERMINAL		DOCUMENT NO: 98ASA00815D	REV: B
		STANDARD: NON-JEDEC	
		SOT1630-2	22 MAY 2018

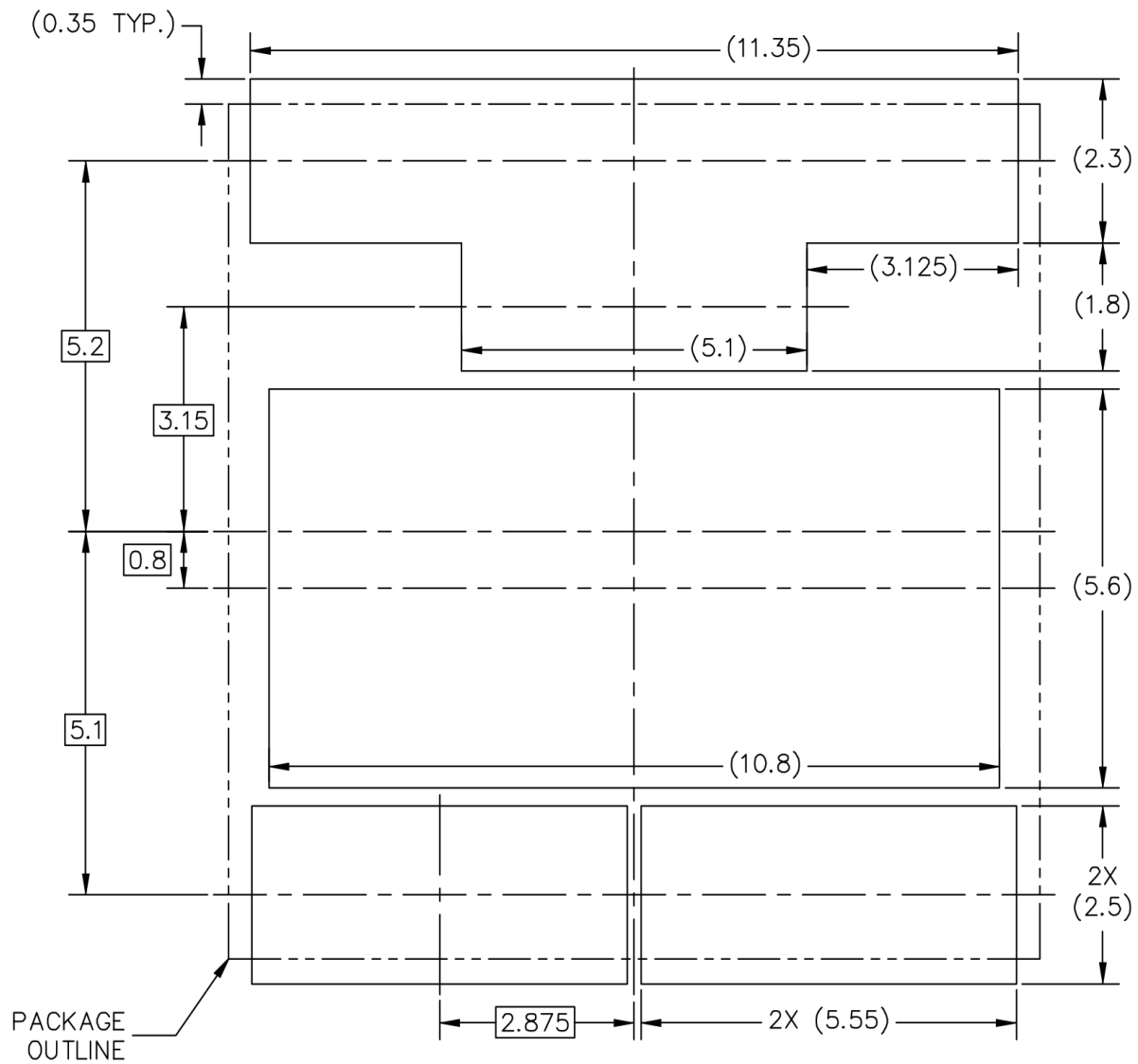

PCB DESIGN GUIDELINES – SOLDER MASK OPENING PATTERN 2

THIS SHEET SERVES ONLY AS A GUIDELINE TO HELP DEVELOP A USER SPECIFIC SOLUTION. DEVELOPMENT EFFORT WILL STILL BE REQUIRED BY END USERS TO OPTIMIZE PCB MOUNTING PROCESSES AND BOARD DESIGN IN ORDER TO MEET INDIVIDUAL / SPECIFIC REQUIREMENTS.

© NXP SEMICONDUCTORS N.V. ALL RIGHTS RESERVED	MECHANICAL OUTLINE	PRINT VERSION NOT TO SCALE	
TITLE: PQFN, 12 X 12 X 2.1 PKG, 0.9 PITCH, 16 TERMINAL		DOCUMENT NO: 98ASA00815D	REV: B
		STANDARD: NON-JEDEC	
		SOT1630-2	22 MAY 2018

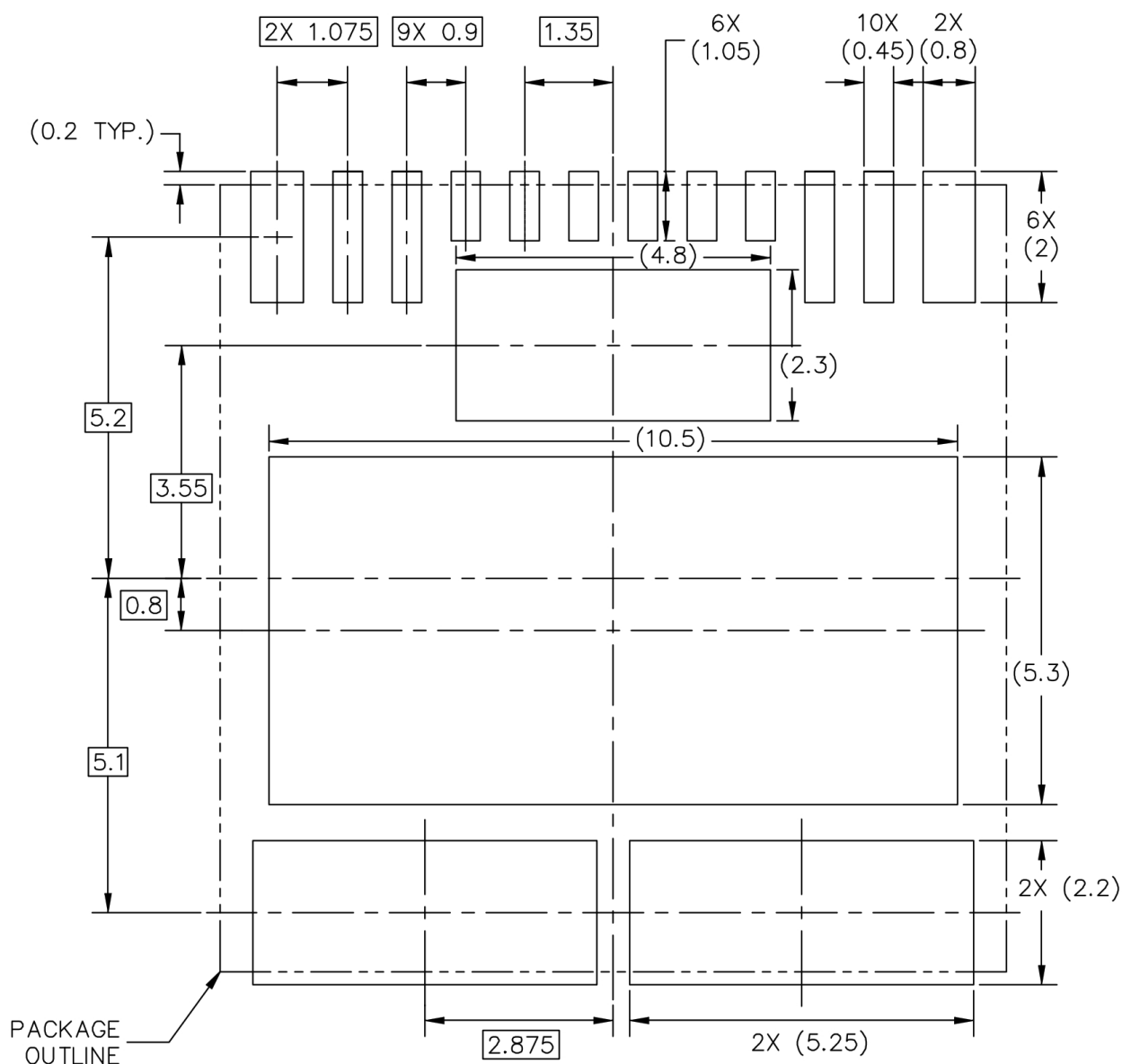

PCB CU GUIDELINES – I/O PADS & SOLDERABLE AREAS

THIS SHEET SERVES ONLY AS A GUIDELINE TO HELP DEVELOP A USER SPECIFIC SOLUTION. DEVELOPMENT EFFORT WILL STILL BE REQUIRED BY END USERS TO OPTIMIZE PCB MOUNTING PROCESSES AND BOARD DESIGN IN ORDER TO MEET INDIVIDUAL / SPECIFIC REQUIREMENTS.

© NXP SEMICONDUCTORS N.V. ALL RIGHTS RESERVED	MECHANICAL OUTLINE	PRINT VERSION NOT TO SCALE
TITLE: PQFN, 12 X 12 X 2.1 PKG, 0.9 PITCH, 16 TERMINAL	DOCUMENT NO: 98ASA00815D	REV: B
	STANDARD: NON-JEDEC	
	SOT1630-2	22 MAY 2018



## NOTES:

1. ALL DIMENSIONS ARE IN MILLIMETERS.
2. DIMENSIONING AND TOLERANCING PER ASME Y14.5M-1994.
3. THIS IS NON-JEDEC REGISTERED PACKAGE.

4.  COPLANARITY APPLIES TO LEADS AND CORNER LEADS.

5. MINIMUM METAL GAP IS GUARANTEED TO BE 0.25 MM.

© NXP SEMICONDUCTORS N.V. ALL RIGHTS RESERVED	MECHANICAL OUTLINE	PRINT VERSION NOT TO SCALE	
TITLE: PQFN, 12 X 12 X 2.1 PKG, 0.9 PITCH, 16 TERMINAL		DOCUMENT NO: 98ASA00815D	REV: B
		STANDARD: NON-JEDEC	
		SOT1630-2	22 MAY 2018

## Additional documentation

### Thermal addendum (Rev 4.0)

#### Introduction

This thermal addendum is provided as a supplement to the 33982 technical datasheet. The addendum provides thermal performance information that may be critical in the design and development of system applications. All electrical, application, and packaging information is provided in the datasheet.

#### Packaging and Thermal Considerations

This package is a dual die package. There are two heat sources in the package independently heating with  $P_1$  and  $P_2$ . This results in two junction temperatures,  $T_{J1}$  and  $T_{J2}$ , and a thermal resistance matrix with  $R_{\theta JA mn}$ .

For  $m, n = 1$ ,  $R_{\theta JA11}$  is the thermal resistance from Junction 1 to the reference temperature while only heat source 1 is heating with  $P_1$ .

For  $m = 1, n = 2$ ,  $R_{\theta JA12}$  is the thermal resistance from Junction 1 to the reference temperature while heat source 2 is heating with  $P_2$ . This applies to  $R_{\theta J21}$  and  $R_{\theta J22}$ , respectively.

$$\begin{Bmatrix} T_{J1} \\ T_{J2} \end{Bmatrix} = \begin{bmatrix} R_{\theta JA11} & R_{\theta JA12} \\ R_{\theta JA21} & R_{\theta JA22} \end{bmatrix} \cdot \begin{Bmatrix} P_1 \\ P_2 \end{Bmatrix}$$

The stated values are solely for a thermal performance comparison of one package to another in a standardized environment. This methodology is not meant to and does not predict the performance of a package in an application-specific environment. Stated values were obtained by measurement and simulation according to the standards listed below.

#### Standards

**Table 20. Thermal performance comparison**

Thermal Resistance	1 = Power Chip, 2 = Logic Chip [°C/W]		
	$m = 1, n = 1$	$m = 1, n = 2$ $m = 2, n = 1$	$m = 2, n = 2$
$R_{\theta JA mn}$ <sup>(1), (2)</sup>	20	16	39
$R_{\theta JB mn}$ <sup>(2), (3)</sup>	6	2.0	26
$R_{\theta JA mn}$ <sup>(1), (4)</sup>	53	40	73
$R_{\theta JC mn}$ <sup>(5)</sup>	<0.5	0.0	1.0

Notes:

1. Per JEDEC JESD51-2 at natural convection, still air condition.
2. 2s2p thermal test board per JEDEC JESD51-7 and JESD51-5.
3. Per JEDEC JESD51-8, with the board temperature on the center trace near the power outputs.
4. Single layer thermal test board per JEDEC JESD51-3 and JESD51-5.
5. Thermal resistance between the die junction and the exposed pad, "infinite" heat sink attached to exposed pad.

**33982**

**High-side Switch**

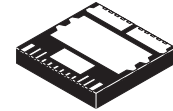

**98ARL10521D**  
**98ASA00815D**  
**16-PIN PQFN**  
**12 mm x 12 mm**

**Note** For package dimensions, refer to 98ARL10521D and 98ASA00815D.

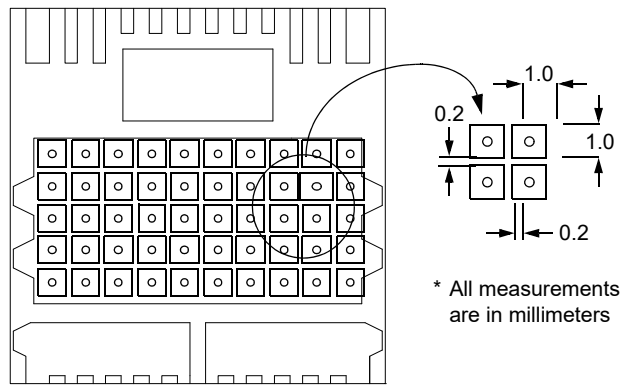

Note: Recommended via diameter is 0.5 mm. PTH (plated through hole) via must be plugged / filled with epoxy or solder mask in order to minimize void formation and to avoid any solder wicking into the via.

**Figure 13. Surface mount for power PQFN with exposed pads**

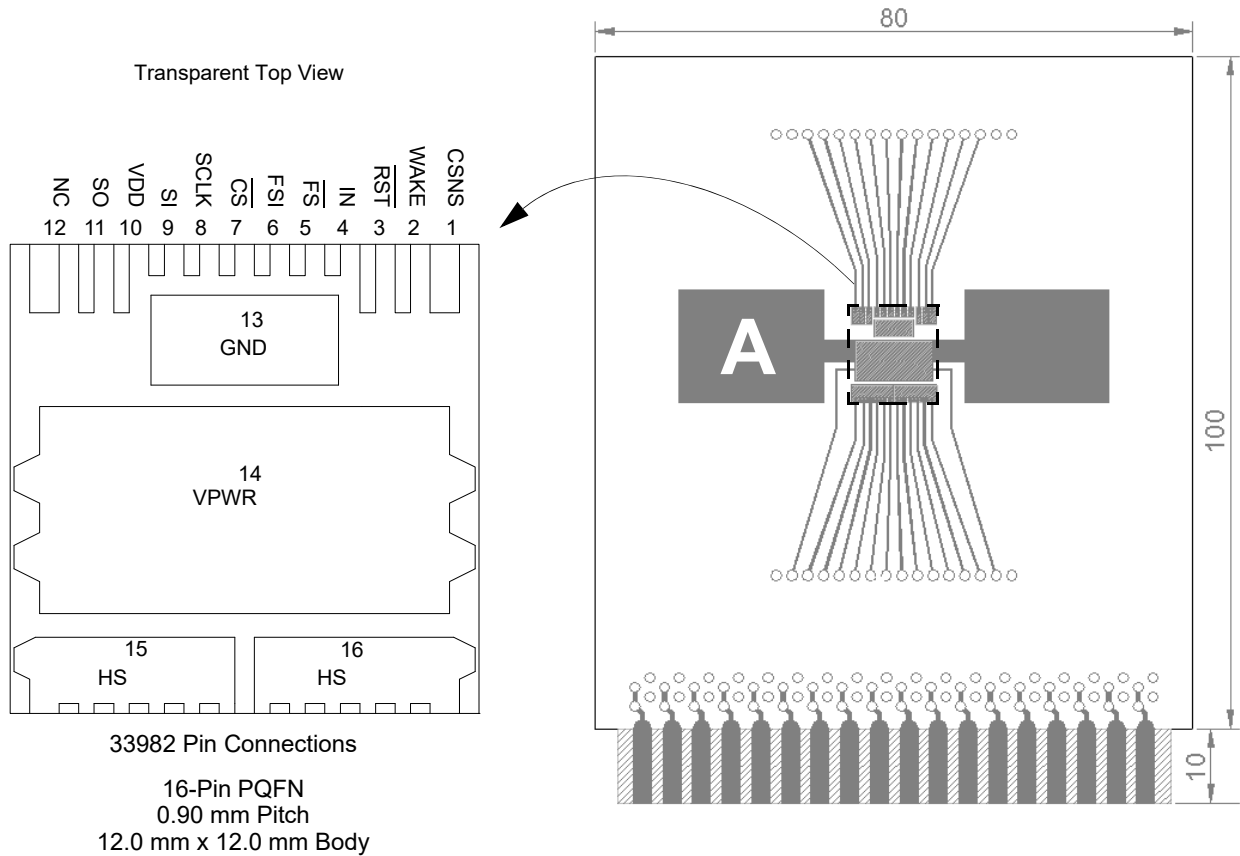

**Figure 14. Thermal test board**

**Table 21. Device on thermal test board**

Material:	Single layer printed circuit board FR4, 1.6 mm thickness Cu traces, 0.07 mm thickness
Outline:	80 mm x 100 mm board area, including edge connector for thermal testing
Area A:	Cu heat-spreading areas on board surface
Ambient Conditions:	Natural convection, still air

**Table 22. Thermal resistance performance**

Thermal Resistance	Area A (mm <sup>2</sup> )	1 = Power Chip, 2 = Logic Chip (°C/W)		
		<i>m</i> = 1, <i>n</i> = 1	<i>m</i> = 1, <i>n</i> = 2 <i>m</i> = 2, <i>n</i> = 1	<i>m</i> = 2, <i>n</i> = 2
$R_{\theta JA m n}$	0	55	42	74
	300	41	32	66
	600	39	29	65

$R_{\theta JA}$  is the thermal resistance between die junction and ambient air. This device is a dual die package. Index *m* indicates the die that is heated. Index *n* refers to the number of the die where the junction temperature is sensed.

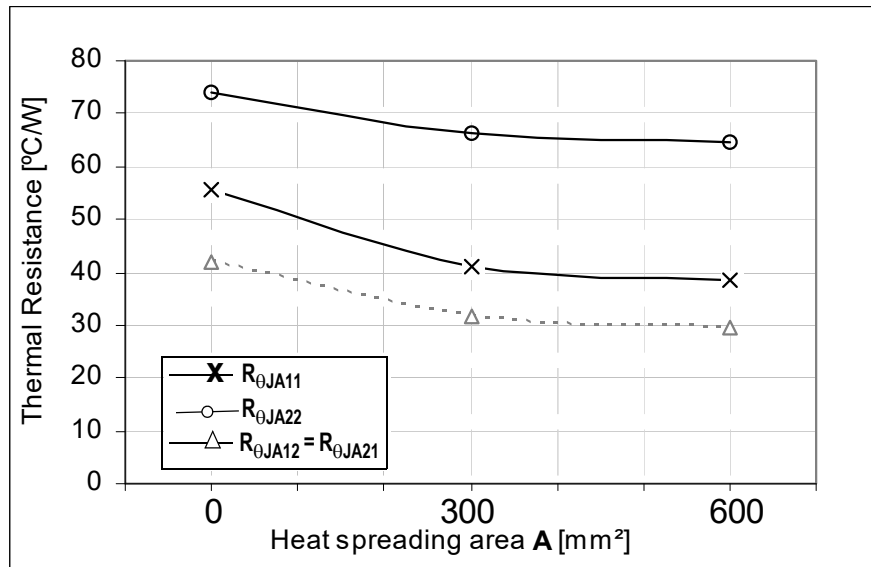

**Figure 15. Device on thermal test board  $R_{\theta JA}$**

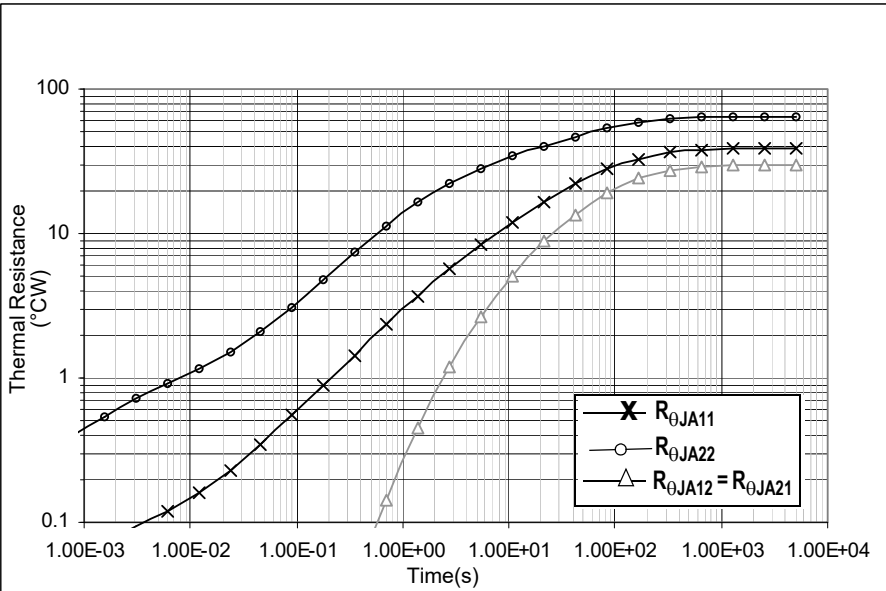

Figure 16. Transient thermal resistance  $R_{\theta JA}$  (1.0 W step response) device on thermal test board area  $A = 600(\text{mm}^2)$

## Revision history

Revision	Date	Description of Changes
10.0	2/2006	<ul style="list-style-type: none"> <li>Implemented Revision History page</li> <li>Deletion of MC33982 part number, replaced with MC33982B.</li> </ul>
11.0	5/2006	<ul style="list-style-type: none"> <li>Corrected <a href="#">Pin connections</a> to the proper case outline</li> <li>Added final sentence to <a href="#">Open Load Fault (Non-Latching)</a></li> <li>Corrected heading labels on <a href="#">Input timing switching characteristics</a></li> <li>Changed labels in the <a href="#">Typical applications</a> drawing</li> <li>Corrected <a href="#">Package dimensions</a> to Revision C</li> <li>Added <a href="#">Thermal addendum (Rev 4.0)</a>.</li> </ul>
12.0	1/2007	<ul style="list-style-type: none"> <li>Added RoHS logo to the data sheet</li> </ul>
13.0	7/2007	<ul style="list-style-type: none"> <li>Added <a href="#">Functional internal block description</a></li> <li>Minor corrections to <a href="#">Serial output bit map descriptions</a> and <a href="#">Device behavior in case of undervoltage</a></li> </ul>
14.0	6/2008	<ul style="list-style-type: none"> <li>Changed the labeling header on <a href="#">Dynamic electrical characteristics</a> from 150 to 125 degrees C</li> <li>Updated Freescale form and style</li> </ul>
15.0	7/2009	<ul style="list-style-type: none"> <li>Added Current Sense Leakage to Static Electrical Characteristics table (Table 3).</li> </ul>
16.0	10/2009	<ul style="list-style-type: none"> <li>Added MC33982C to the ordering information</li> <li>Added a Device Variations table</li> </ul>
17.0	5/2012	<ul style="list-style-type: none"> <li>Removed MC33982BPNA</li> <li>Updated orderable part number from MC33982CPNA to MC33982CHFK</li> <li>Updated <sup>(7)</sup></li> <li>Updated <a href="#">Soldering information</a></li> <li>Updated Freescale form and style</li> </ul>
18.0	10/2012	<ul style="list-style-type: none"> <li>Made limit changes to <a href="#">Dynamic electrical characteristics</a> min, typ, and max.</li> </ul>
	9/2014	<ul style="list-style-type: none"> <li>Corrected Orderable Part number information.</li> <li>Updated Freescale form and style</li> <li>Updated back page</li> </ul>
	10/2016	<ul style="list-style-type: none"> <li>Updated document to NXP form and style</li> </ul>
19.0	07/2023	<ul style="list-style-type: none"> <li>Updated per CIN 2023060241.</li> <li>Added package outline drawing number 98ASA00815D under "Bottom View" on page 1.</li> <li><a href="#">Table 1. Orderable part variations (1)</a>: added part number MC33982EHFK.</li> <li><a href="#">Table 3. Maximum ratings</a> revised as follows: <ul style="list-style-type: none"> <li><math>E_{CL}</math>: removed "33982B" from the Rating column and the associated value of "1.5" from the Value column.</li> <li><math>E_{CL}</math>: inserted "33982E" in the Rating column with the associated value of "0.6" in the Value column.</li> </ul> </li> <li><a href="#">Table 4. Static electrical characteristics</a>: revised as follows: <ul style="list-style-type: none"> <li><math>I_{OCH0}/I_{OCH1}</math>, Output Overcurrent High Detection Levels (<math>9.0\text{ V} &lt; V_{PWR} &lt; 16\text{ V}</math>): added two new rows for CHFK, two new rows for EHFK and removed the original values.</li> <li><math>I_{OCL0}/I_{OCL7}</math>, Overcurrent Low Detection Levels (SOCL[2:0]): added "CHFK" to the characteristic following "(SOCL[2:0])".</li> <li><math>I_{OCL0}/I_{OCL7}</math>, Overcurrent Low Detection Levels (SOCL[2:0]) EHFK: added new row and values.</li> <li><math>C_{SR0}/C_{SR1}</math>, Current Sense Ratio (<math>9.0\text{ V} &lt; V_{PWR} &lt; 16\text{ V}</math>, <math>CSNS &lt; 4.5\text{ V}</math>): added "CHFK" after "4.5v".</li> <li><math>C_{SR0}/C_{SR1}</math>, Current Sense Ratio (<math>9.0\text{ V} &lt; V_{PWR} &lt; 16\text{ V}</math>, <math>CSNS &lt; 4.5\text{ V}</math>) EHFK: added new row and values.</li> </ul> </li> <li><a href="#">Table 5. Dynamic electrical characteristics</a>: revised as follows: <ul style="list-style-type: none"> <li><math>SR_{RA\_SLOW}</math>: added rows for CHFK and EHFK and their associated Min, Typ, and Max values.</li> <li><math>SR_{RA\_FAST}</math>: added rows for CHFK and EHFK and their associated Min, Typ, and Max values and removed the original values.</li> <li><math>SR_{FA\_SLOW}</math>: added rows for CHFK and EHFK and their associated Min, Typ, and Max values and removed the original values.</li> <li><math>SR_{FA\_FAST}</math>: added rows for CHFK and EHFK and their associated Min, Typ, and Max values and removed the original values.</li> <li><math>t_{DLY(ON)}</math>: added rows for CHFK and EHFK and their associated Min, Typ, and Max values and removed the original values.</li> <li><math>t_{DLY\_SLOW(OFF)}</math>: added rows for CHFK and EHFK and their associated Min, Typ, and Max values and removed the original values.</li> <li><math>t_{DLY\_FAST(OFF)}</math>: added rows for CHFK and EHFK and their associated Min, Typ, and Max values and removed the original values.</li> </ul> </li> <li>Added package outline drawing number "and 98ASA00815D" and Table 19 below "Package dimensions" on page 30.</li> <li><a href="#">Packaging</a>: Updated the package images from 98ARL10521D to 98ASA00815D.</li> </ul>

Revision	Date	Description of Changes
20.0	11/2023	<ul style="list-style-type: none"> <li>• <a href="#">Table 4. Static electrical characteristics</a> revised as follows: <ul style="list-style-type: none"> <li>• <math>I_{OCH0}/I_{OCH1}</math>, Output Overcurrent High Detection Levels (<math>9.0\text{ V} &lt; V_{PWR} &lt; 16\text{ V}</math>): Changed CHFK Min value from "180" to "80"</li> </ul> </li> </ul>

## Legal information

### Definitions

**Draft** — A draft status on a document indicates that the content is still under internal review and subject to formal approval, which may result in modifications or additions. NXP Semiconductors does not give any representations or warranties as to the accuracy or completeness of information included in a draft version of a document and shall have no liability for the consequences of use of such information.

### Disclaimers

**Limited warranty and liability** - Information in this document is believed to be accurate and reliable. However, NXP Semiconductors does not give any representations or warranties, expressed or implied, as to the accuracy or completeness of such information and shall have no liability for the consequences of use of such information. NXP Semiconductors takes no responsibility for the content in this document if provided by an information source outside of NXP Semiconductors.

In no event shall NXP Semiconductors be liable for any indirect, incidental, punitive, special or consequential damages (including - without limitation - lost profits, lost savings, business interruption, costs related to the removal or replacement of any products or rework charges) whether or not such damages are based on tort (including negligence), warranty, breach of contract or any other legal theory.

Notwithstanding any damages that customer might incur for any reason whatsoever, NXP Semiconductors' aggregate and cumulative liability towards customer for the products described herein shall be limited in accordance with the Terms and conditions of commercial sale of NXP Semiconductors.

**Right to make changes** - NXP Semiconductors reserves the right to make changes to information published in this document, including without limitation specifications and product descriptions, at any time and without notice. This document supersedes and replaces all information supplied prior to the publication hereof.

**Suitability for use in automotive applications** — This NXP product has been qualified for use in automotive applications. If this product is used by customer in the development of, or for incorporation into, products or services (a) used in safety critical applications or (b) in which failure could lead to death, personal injury, or severe physical or environmental damage (such products and services hereinafter referred to as "Critical Applications"), then customer makes the ultimate design decisions regarding its products and is solely responsible for compliance with all legal, regulatory, safety, and security related requirements concerning its products, regardless of any information or support that may be provided by NXP. As such, customer assumes all risk related to use of any products in Critical Applications and NXP and its suppliers shall not be liable for any such use by customer. Accordingly, customer will indemnify and hold NXP harmless from any claims, liabilities, damages and associated costs and expenses (including attorneys' fees) that NXP may incur related to customer's incorporation of any product in a Critical Application.

**Applications** - Applications that are described herein for any of these products are for illustrative purposes only. NXP Semiconductors makes no representation or warranty that such applications will be suitable for the specified use without further testing or modification. Customers are responsible for the design and operation of their applications and products using NXP Semiconductors products, and NXP Semiconductors accepts no liability for any assistance with applications or customer product design. It is customer's sole responsibility to determine whether the NXP Semiconductors product is suitable and fit for the customer's applications and products planned, as well as for the planned application and use of customer's third party customer(s). Customers should provide appropriate design and operating safeguards to minimize the risks associated with their applications and products.

NXP Semiconductors does not accept any liability related to any default, damage, costs or problem which is based on any weakness or default in the customer's applications or products, or the application or use by customer's third party customer(s). Customer is responsible for doing all necessary testing for the customer's applications and products using NXP Semiconductors products in order to avoid a default of the applications and the products or of the application or use by customer's third party customer(s). NXP does not accept any liability in this respect.

**Limiting values** - Stress above one or more limiting values (as defined in the Absolute Maximum Ratings System of IEC 60134) will cause permanent damage to the device. Limiting values are stress ratings only and (proper) operation of the device at these or any other conditions above those given in the Recommended operating conditions section (if present) or the Characteristics sections of this document is not warranted. Constant or repeated exposure to limiting values will permanently and irreversibly affect the quality and reliability of the device.

**Terms and conditions of commercial sale** - NXP Semiconductors products are sold subject to the general terms and conditions of commercial sale, as published at <http://www.nxp.com/profile/terms>, unless otherwise agreed in a valid written individual agreement. In case an individual agreement is concluded only the terms and conditions of the respective agreement shall apply. NXP Semiconductors hereby expressly objects to applying the customer's general terms and conditions with regard to the purchase of NXP Semiconductors products by customer.

**No offer to sell or license** - Nothing in this document may be interpreted or construed as an offer to sell products that is open for acceptance or the grant, conveyance or implication of any license under any copyrights, patents or other industrial or intellectual property rights.

**Quick reference data** - The Quick reference data is an extract of the product data given in the Limiting values and Characteristics sections of this document, and as such is not complete, exhaustive or legally binding.

**Export control** - This document as well as the item(s) described herein may be subject to export control regulations. Export might require a prior authorization from competent authorities.

**Translations** — A non-English (translated) version of a document, including the legal information in that document, is for reference only. The English version shall prevail in case of any discrepancy between the translated and English versions.

**Security** — Customer understands that all NXP products may be subject to unidentified vulnerabilities or may support established security standards or specifications with known limitations. Customer is responsible for the design and operation of its applications and products throughout their lifecycles to reduce the effect of these vulnerabilities on customer's applications and products. Customer's responsibility also extends to other open and/or proprietary technologies supported by NXP products for use in customer's applications. NXP accepts no liability for any vulnerability. Customer should regularly check security updates from NXP and follow up appropriately.

Customer shall select products with security features that best meet rules, regulations, and standards of the intended application and make the ultimate design decisions regarding its products and is solely responsible for compliance with all legal, regulatory, and security related requirements concerning its products, regardless of any information or support that may be provided by NXP.

NXP has a Product Security Incident Response Team (PSIRT) (reachable at [PSIRT@nxp.com](mailto:PSIRT@nxp.com)) that manages the investigation, reporting, and solution release to security vulnerabilities of NXP products.

**NXP B.V.** — NXP B.V. is not an operating company and it does not distribute or sell products.

#### **Trademarks**

Notice: All referenced brands, product names, service names, and trademarks are the property of their respective owners.

**NXP** — wordmark and logo are trademarks of NXP B.V.

Document Number: MC33982  
Rev. 20.0  
11/2023



## Looking for pricing, stock, or lifecycle information?

Click below to explore more details on WIN SOURCE:

 [View MC33982CHFKR2 on WIN SOURCE](#)

 [NXP / Nexperia Information](#)

## Optimize Your Supply Chain with WIN SOURCE Solutions

-  Global Sourcing Solution
-  Obsolete Management
-  Cost Control Management
-  Shortage Management
-  Alternative Solution
-  Excess Inventory Management