



**THE DATASHEET OF
LT8309HS5#TRMPBF**



Secondary-Side Synchronous Rectifier Driver

FEATURES

- Works with DCM and BCM/CrCM Conduction Mode Flyback Topologies
- V_{CC} : 4.5V to 40V
- Supports Up to 150V MOSFETs
- 26ns Turn-Off Propagation Delay
- Accurate Minimum On and Off Timers for Reliable Operation
- Adjustable and Accurate Trip Point: +5mV to -30mV
- 1 Ω Gate Driver Pull-Down
- SOT-23 5-Lead Package

APPLICATIONS

- High Output Current Flybacks
- High Efficiency Flybacks

DESCRIPTION

The **LT[®]8309** is a secondary-side synchronous rectifier driver that replaces the output rectifier diode in a flyback topology. By replacing the diode with a N-channel MOSFET, applications are no longer restricted by the heat constraints of the output diode. The IC replicates the behavior of a diode by sensing the drain-to-source voltage to determine when the current becomes negative. The LT8309's low minimum on- and off-times help improve noise immunity.

The fast propagation delay of 26ns allows applications to operate in discontinuous conduction mode (DCM) and critical conduction mode (CrCM). The gate driver features a 0.8 Ω pull-down device for fast turn-offs. The 40V V_{CC} rating allows the part to be driven from the output voltage or the rectified drain voltage of the MOSFET. A low quiescent current of 400 μ A maximizes efficiency at low output currents.

LT, LT, LTC, LTM, Linear Technology and the Linear logo are registered trademarks of Linear Technology Corporation. All other trademarks are the property of their respective owners.

TYPICAL APPLICATION

40W, 5V Isolated Telecom Supply

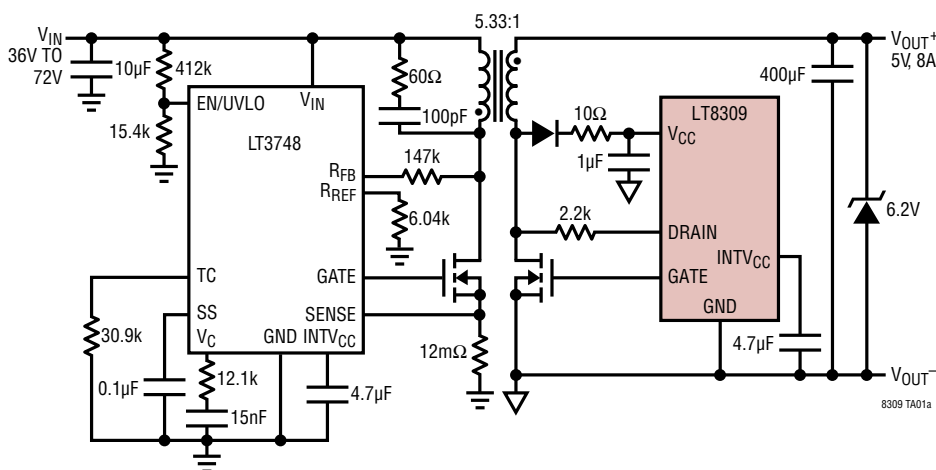

Efficiency vs Load Current

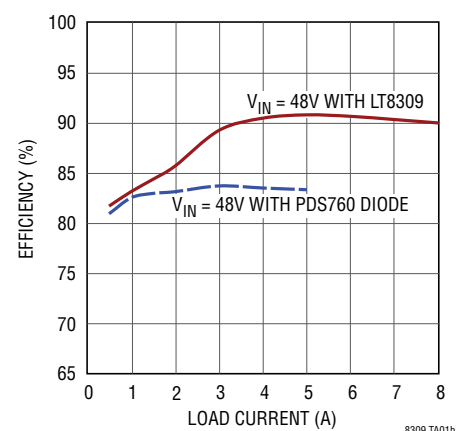

LT8309

ABSOLUTE MAXIMUM RATINGS

(Note 1)

V_{CC}	40V
INTV _{CC} GATE	10V
DRAIN.....	150V
Maximum Junction Temperature	125°C
Operating Temperature Range (Note 2)	
LT8309E	-40°C to 125°C
LT8309I	-40°C to 125°C
LT8309H.....	-40°C to 150°C
Storage Temperature Range	-65°C to 150°C

PIN CONFIGURATION

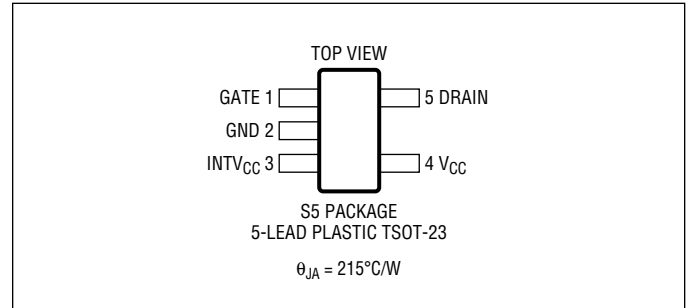

ORDER INFORMATION

LEAD FREE FINISH	TAPE AND REEL	PART MARKING*	PACKAGE DESCRIPTION	TEMPERATURE RANGE
LT8309ES5#PBF	LT8309ES5#TRPBF	LTGFZ	5-Lead Plastic TSOT-23	-40°C to 125°C
LT8309IS5#PBF	LT8309IS5#TRPBF	LTGFZ	5-Lead Plastic TSOT-23	-40°C to 125°C
LT8309HS5#PBF	LT8309HS5#TRPBF	LTGFZ	5-Lead Plastic TSOT-23	-40°C to 150°C

Consult LTC Marketing for parts specified with wider operating temperature ranges. *The temperature grade is identified by a label on the shipping container.

For more information on lead free part marking, go to: <http://www.linear.com/leadfree/>

For more information on tape and reel specifications, go to: <http://www.linear.com/tapeandreel/>

ELECTRICAL CHARACTERISTICS The ● denotes the specifications which apply over the full operating temperature range, otherwise specifications are at $T_A = 25^\circ\text{C}$.

PARAMETER	CONDITIONS		MIN	TYP	MAX	UNITS
Input Voltage Range		●	4.5		40	V
V_{CC} Quiescent Current	Not Switching, $INTV_{CC} = 8\text{V}$			300	345	μA
Comparator						
Turn-On Threshold	$R_S = 0\Omega$	●	-69	-57	-45	mV
Turn-Off Threshold	$R_S = 0\Omega$	●	17 16	21	25 28	mV mV
Drain Voltage Latch Reset	$R_S = 0\Omega$			1.21		V
Minimum Off-Time			75	95	115	ns
Minimum On-Time			310	360	410	ns
Drain Current	Out of Pin	●	9.5	10	10.5	μA
INTV_{CC} Linear Regulator						
INTV _{CC} Quiescent Current	Not Switching, $INTV_{CC} = 8\text{V}$			100	117	μA
INTV _{CC} Voltage Range			4.5		10	V
INTV _{CC} Regulation Voltage		●	6.8	7	7.2	V
INTV _{CC} UVLO					4.03	V
Dropout (V_{CC} to INTV _{CC})	$I_{INTV_{CC}} = -10\text{mA}$, $V_{IN} = 7\text{V}$		1	1.3	1.6	V
Current Limit		●	30	42	55	mA
Gate Driver						
Turn-On Propagation Delay ($t_{D(ON)}$)	$R_S = 0\Omega$, -100mV_{OD} , V_{DS} to V_{GATE}			31	40	ns
Turn-Off Propagation Delay ($t_{D(OFF)}$)	$R_S = 0\Omega$, -100mV_{OD} , V_{DS} to V_{GATE}			26	36	ns
t_r GATE Driver Output Rise Time	$C_L = 3300\text{pF}$			21		ns
t_f GATE Driver Output Fall Time	$C_L = 3300\text{pF}$			11		ns
Pull-Up Resistance				2.7		Ω
Pull-Down Resistance				0.8		Ω

Note 1: Stresses beyond those listed under Absolute Maximum Ratings may cause permanent damage to the device. Exposure to any Absolute Maximum Rating condition for extended periods may affect device reliability and lifetime.

Note 2: The LT8309E is guaranteed to meet performance specifications from 0°C to 125°C operating junction temperature. Specifications over the -40°C to 125°C operating junction temperature range are assured by design, characterization and correlation with statistical process controls. The LT8309I is guaranteed over the full -40°C to 125°C operating junction

temperature range. The LT8309H is guaranteed over the full -40°C to 150°C operating junction temperature range. High junction temperatures degrade operating lifetimes. Operating lifetime is derated at junction temperatures greater than 125°C .

Note 3: The LT8309 includes overtemperature protection that is intended to protect the device during momentary overload conditions. Junction temperature will exceed 150°C when overtemperature protection is active. Continuous operation above the specified maximum operating junction temperature may impair device reliability.

TYPICAL PERFORMANCE CHARACTERISTICS

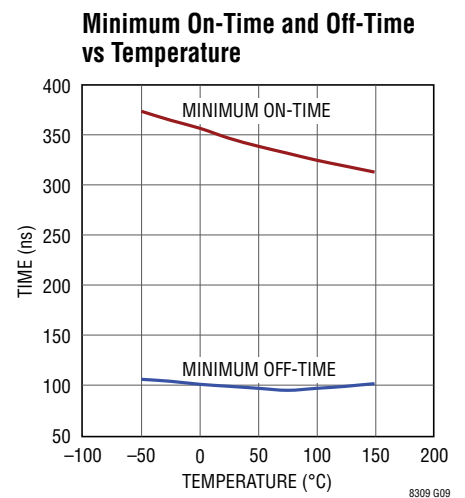
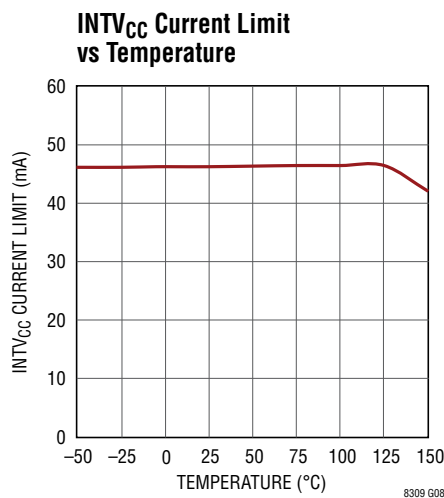
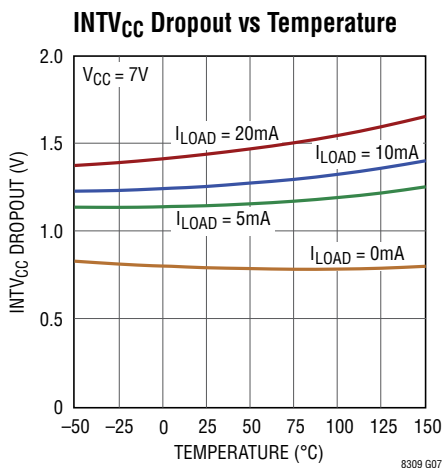
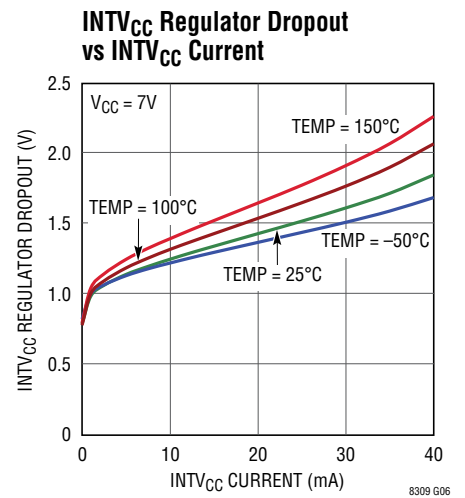
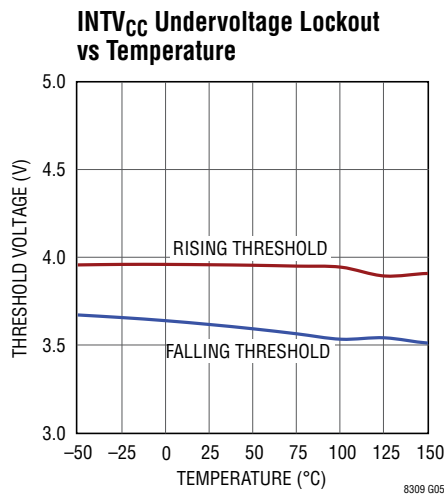
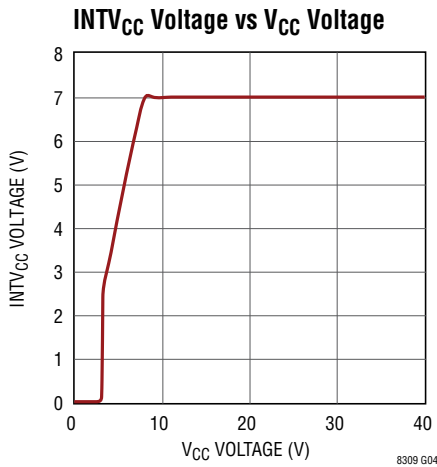
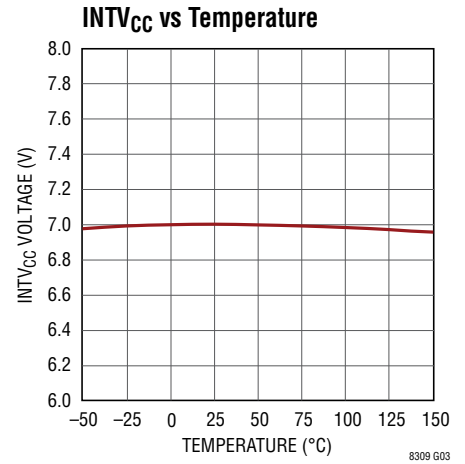
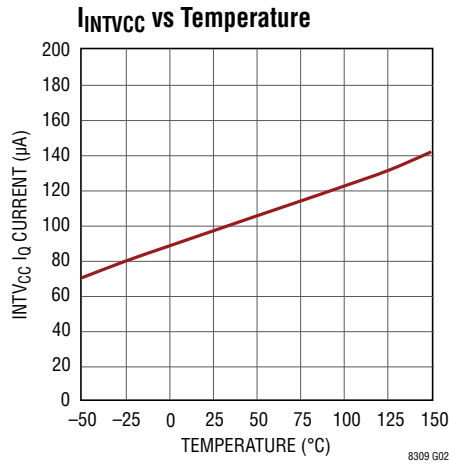
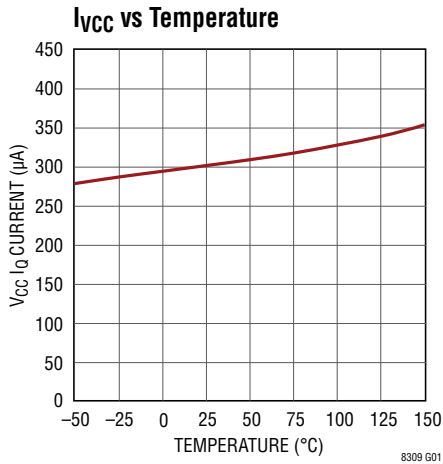

TYPICAL PERFORMANCE CHARACTERISTICS

DRAIN Pin Current vs Temperature

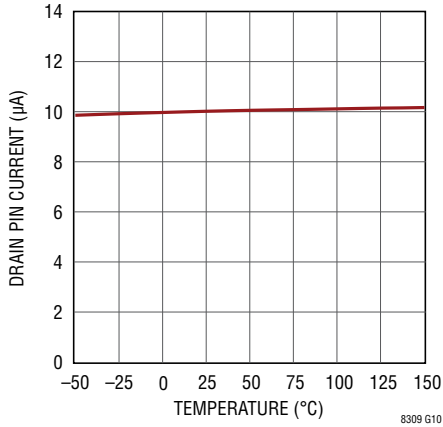

Comparator Turn-On Threshold vs Temperature

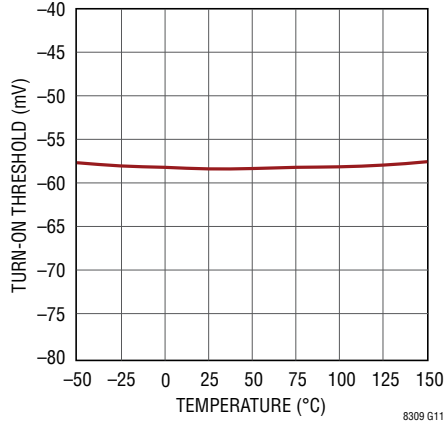

Comparator Turn-Off Threshold vs Temperature

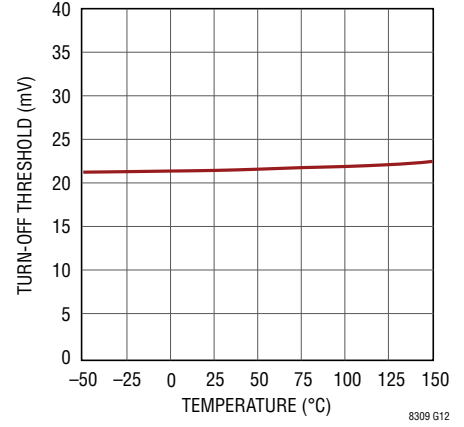

Latch Reset Threshold vs Temperature

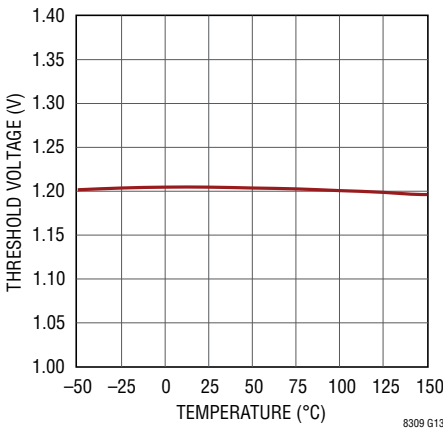

GATE Rise and Fall Time vs Charge

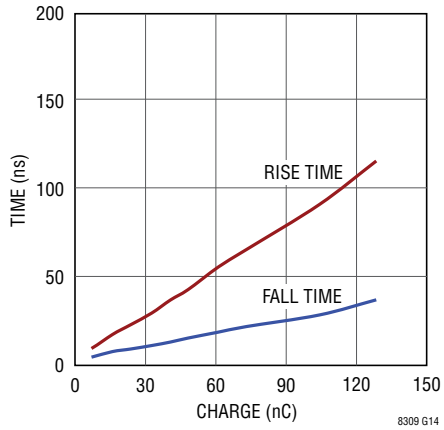

GATE Current vs Charge

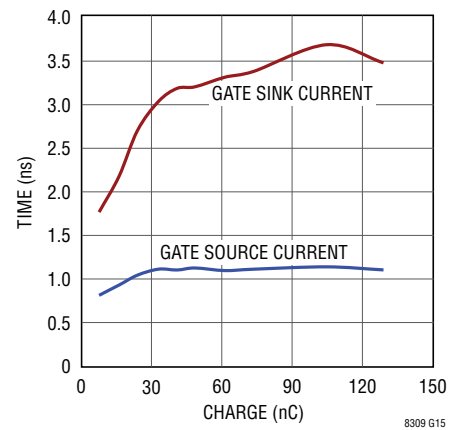

OPERATION

The LT8309 is a synchronous rectifier designed for boundary conduction mode/critical conduction mode and discontinuous mode flyback converters. Existing solutions use a pulse signal from the primary side to control the synchronous rectifier, but the LT8309 senses the drain-source voltage of the MOSFET to control the synchronous rectifier. This technique not only eliminates a transformer, but allows it to work with Linear Technology's line of no-opto critical conduction flyback converters. Synchronous rectification improves efficiency and more importantly increases the maximum output current when compared to nonsynchronous designs.

The LT8309 imitates the behavior of a diode but replaces the forward voltage with the $R_{DS(ON)}$ of an external N-channel MOSFET. The LT8309 includes an LDO, a very fast comparator and a powerful gate driver.

An external resistor connects the part's DRAIN pin to the drain of the MOSFET. This resistor sets the trip point of the comparator with a precise internal current source. To set the trip point to -10mV , a 3000Ω resistor is needed. The trip point decreases by 1mV for every 100Ω added to this drain resistor. This trip point will be referred to as V_{OFFSET} . Figure 1 shows the drain waveform on top and the gate waveform on the bottom. The gate node goes high when the drain node goes 74mV below the V_{OFFSET} . The comparator's output is ignored for a minimum on-time to eliminate the chance that ringing triggers the comparator. After the minimum on-time, the comparator is ready to trigger at the V_{OFFSET} voltage. Once the drain voltage goes above V_{OFFSET} , the gate turns off after a very fast propagation delay, $t_{D(OFF)}$. The body diode begins to conduct again before the current reaches 0A . The drain voltage needs to go above 1.21V and then wait for the minimum off-time before the comparator is re-enabled.

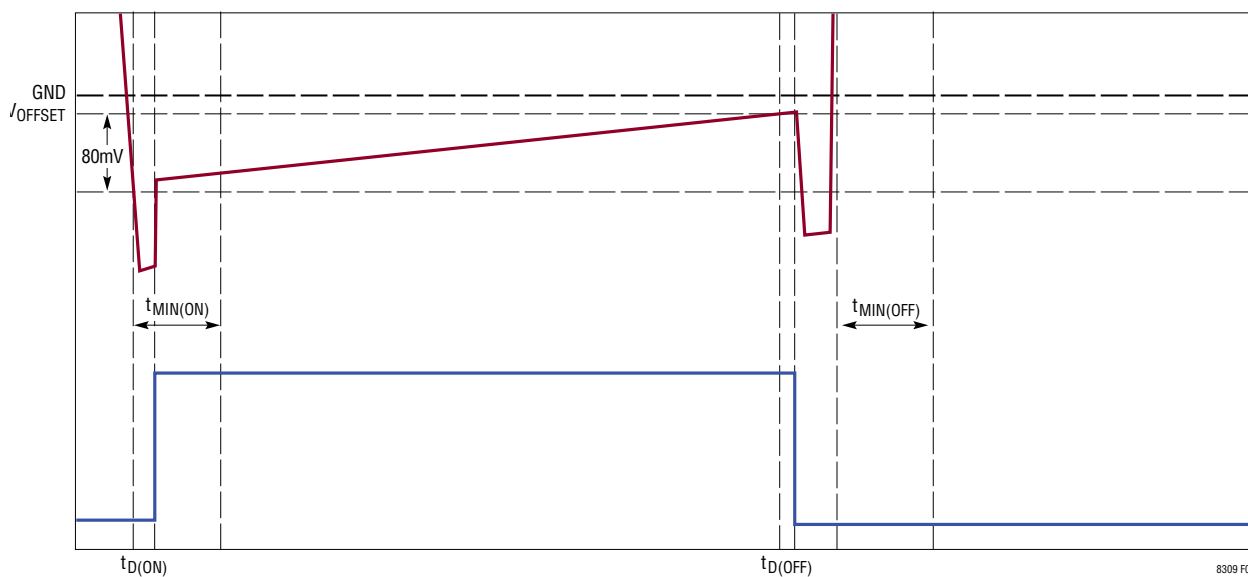

Figure 1. Drain and Gate Waveforms

OPERATION

Undervoltage Lockout

The part features a $INTV_{CC}$ undervoltage lockout (UVLO) to prevent switching until the $INTV_{CC}$ voltage is above 4V.

$INTV_{CC}$ LDO

An internal LDO regulator provides a regulated 7V output from the V_{IN} pin to the $INTV_{CC}$ pin. An output capacitor is needed to provide the current needed for the gate driver. A 4.7 μ F capacitor is recommended and must be placed as close as possible to the $INTV_{CC}$ pin. The current limit for the LDO is 42mA.

MOSFET Selection

A MOSFET's $R_{DS(ON)}$ is important to the operation of the LT8309. The drain-source voltage is used to determine when to turn off the MOSFET. The peak current through the MOSFET times the MOSFET's $R_{DS(ON)}$ should be above 75mV. When this voltage is too low, the high speed comparator may trip early due to ringing on the DRAIN pin. When this voltage is too high, the MOSFET dissipates a large amount of power which causes efficiency to go down and may cause thermal issues with the MOSFET.

Setting the DRAIN Pin Resistor

The DRAIN pin resistor sets when the LT8309 turns off the MOSFET. The trip point, V_{OFFSET} , is set with the following equation:

$$V_{OFFSET} = 20mV - 10\mu A \cdot R_{DRAIN}$$

R_{DRAIN} is the resistor connected between the drain of the MOSFET and the DRAIN pin of the part. R_{DRAIN} needs to be at least 800 Ω to operate correctly. For most applications, V_{OFFSET} should be set at -5mV. High $R_{DS(ON)}$ MOSFETs may require a more negative V_{OFFSET} voltage to keep the drain-to-source current from reversing. If the current is reversing, decrease V_{OFFSET} in 5mV steps to eliminate the cross-conduction.

Short-Circuit Operation

In the Typical Application diagram on Page 1, the V_{CC} pin is connected to the output of the flyback converter. During an output short-circuit condition, the LT8309 is off and the body diode of the MOSFET must handle the short-circuit condition. This puts additional thermal requirements on the MOSFET. The drain voltage of the MOSFET is equal to V_{IN}/N in short-circuit and capable of powering the LT8309 with the circuit in Figure 2. This allows the LT8309

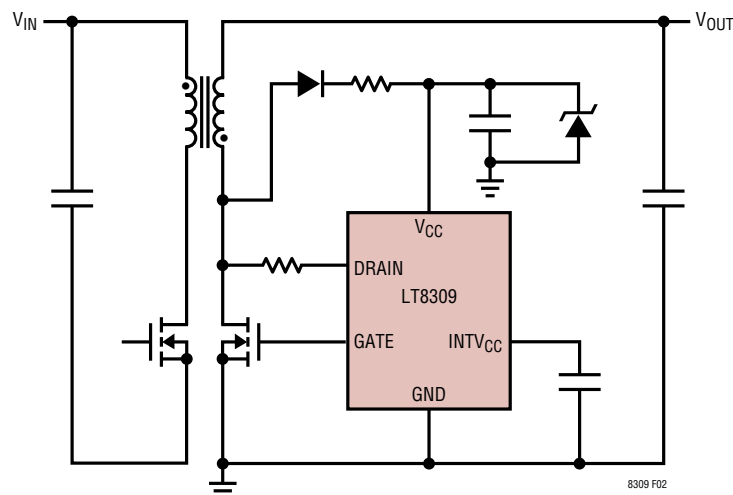

Figure 2. Short-Circuit Application Circuit

OPERATION

to operate during a short, and the current will flow through the low resistance channel of the MOSFET instead of its body diode. Make sure to use a resistor in series with the diode to keep V_{CC} below 40V.

Layout Considerations

The main current loop is the MOSFETs drain-to-source current. This should not share the same ground path as the LT8309. The drain resistor needs to sense directly at the drain of the MOSFET and not have any current of the drain current flow through its metal trace. The drain node of the MOSFET is used as the heat sink and will need to be sized according to the power dissipation requirements. Figure 3 is an example layout of the LT8309.

Effects of the Body Diode

When the discontinuous ring voltage goes below ground, the body diode of the primary-side MOSFET turns on and begins to conduct current. This diode clamps the voltage

to a diode drop below ground. When the current reverses direction, the diode does not turn off immediately, and conducts current in the opposite direction for a small period of time. This is known as the reverse-recovery time. During this time, the magnetizing inductance of the transformer stores energy just like it does when the MOSFET turns on. When the primary-side body diode finally turns off, the energy is transferred to the secondary side and may be enough to turn on the body diode of the secondary MOSFET. Then, the LT8309 turns on its MOSFET for a second time. Since this happens during the discontinuous ring, the primary side may turn on during this time and cause cross conduction. If this problem does occur, one way to improve the reverse-recovery time of the primary side's MOSFET is to add a parallel Schottky diode, which will conduct most of the current and turn off much faster than the body diode. Another way of eliminating this issue is by sizing the turns ratio so that the discontinuous ring never goes below ground.

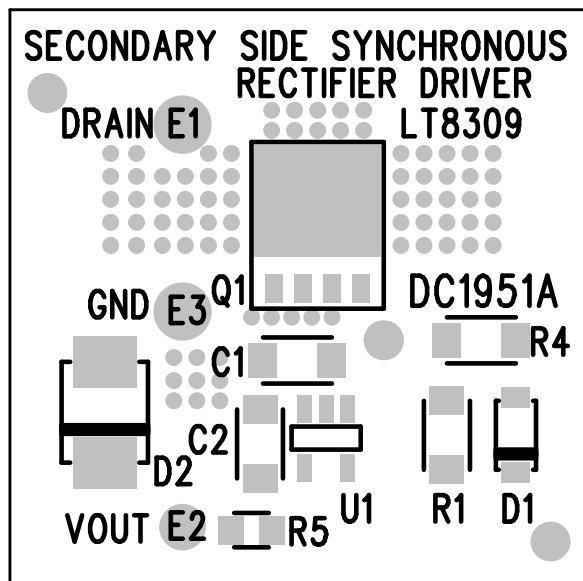

Figure 3. Demo Board Topside Silkscreen

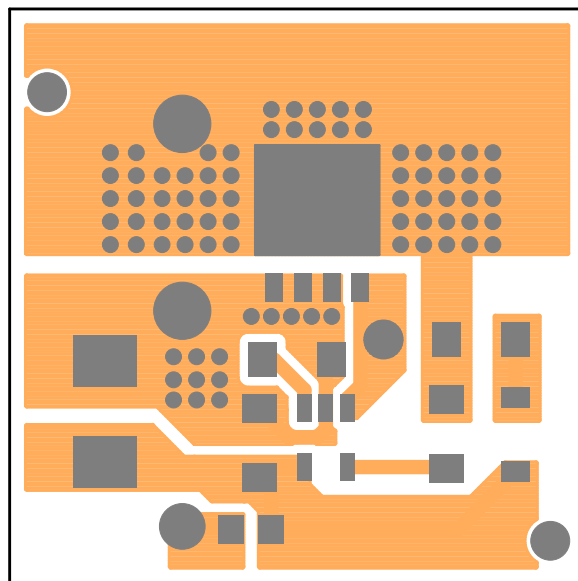
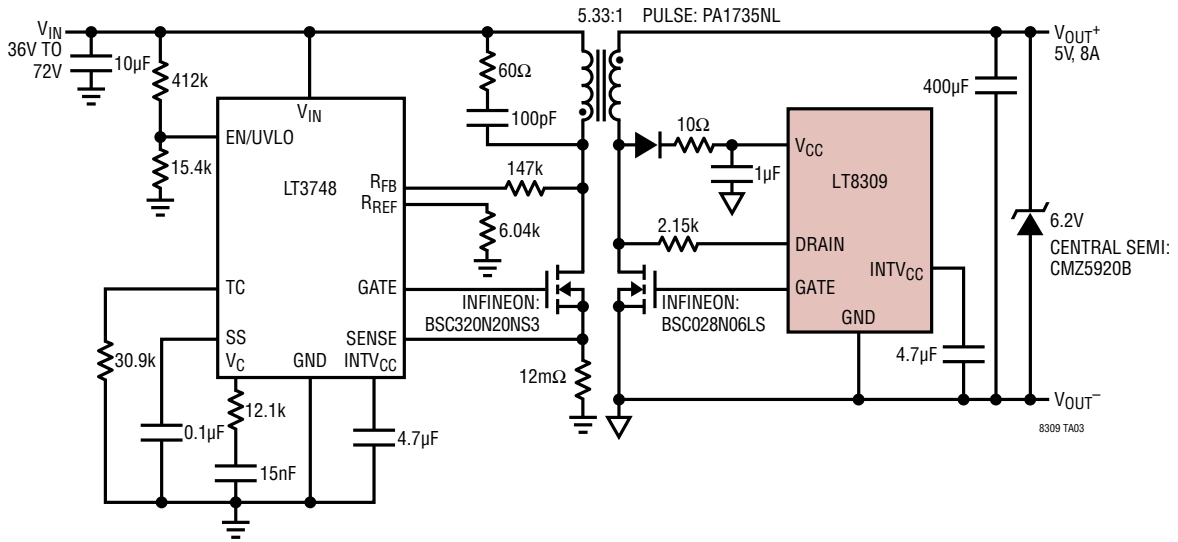

Figure 4. Demo Board Topside Metal

TYPICAL APPLICATIONS

40W, 5V Isolated Telecom Supply



PACKAGE DESCRIPTION

Please refer to <http://www.linear.com/designtools/packaging/> for the most recent package drawings.

S5 Package 3-Lead Plastic TSOT-23 (Reference LTC DWG # 05-08-1635)

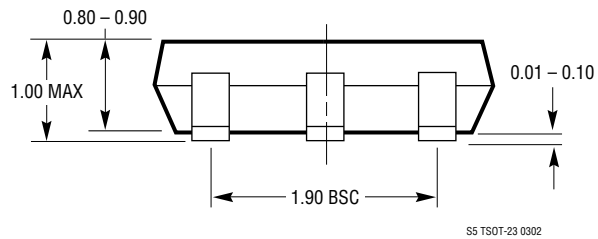
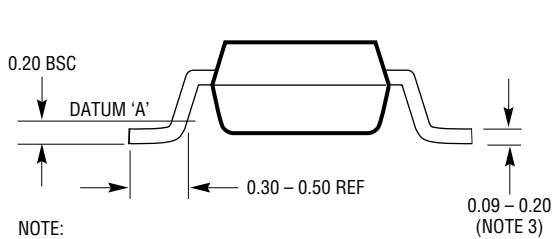
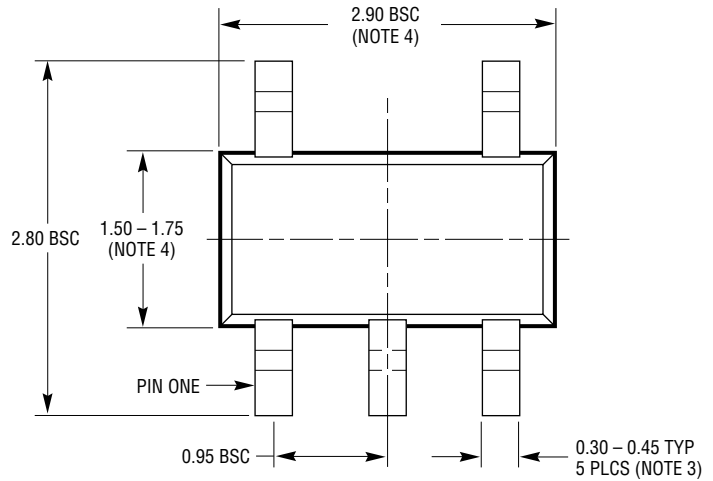
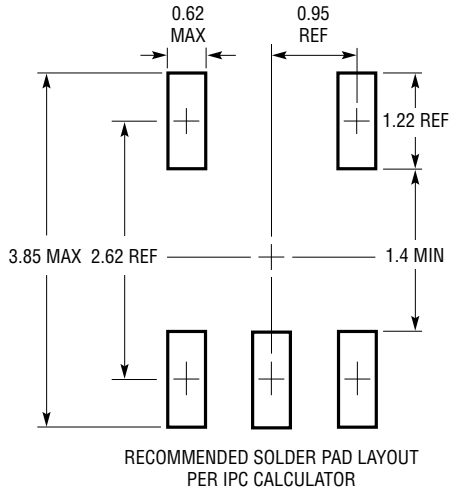

- NOTE:
1. DIMENSIONS ARE IN MILLIMETERS
 2. DRAWING NOT TO SCALE
 3. DIMENSIONS ARE INCLUSIVE OF PLATING
 4. DIMENSIONS ARE EXCLUSIVE OF MOLD FLASH AND METAL BURR
 5. MOLD FLASH SHALL NOT EXCEED 0.254mm
 6. JEDEC PACKAGE REFERENCE IS MO-193

S5 TSOT-23 0302

REVISION HISTORY

REV	DATE	DESCRIPTION	PAGE NUMBER
A	11/14	Added H-Grade Version	2, 3

Looking for pricing, stock, or lifecycle information?

Click below to explore more details on WIN SOURCE:

- ⊖ [View LT8309HS5#TRMPBF on WIN SOURCE](#)
- ⊖ [Analog Devices Inc. Information](#)

Optimize Your Supply Chain with WIN SOURCE Solutions

- ✓ Global Sourcing Solution
- ✓ Obsolete Management
- ✓ Cost Control Management
- ✓ Shortage Management
- ✓ Alternative Solution
- ✓ Excess Inventory Management