

Programmable Gamma-Voltage Generator with Integrated Two-Bank Memory and External EEPROM

FEATURES

- **10-BIT RESOLUTION**
- **12-CHANNEL P-GAMMA**
- **READS FROM EXTERNAL EEPROM**
- **TWO INDEPENDENT PIN-SELECTABLE MEMORY BANKS**
- **RAIL-TO-RAIL OUTPUT:**
 - 300mV Min Swing-to-Rail (10mA)
 - 200mV Min Swing-to-Rail (5mA)
- **LOW SUPPLY CURRENT**
- **SUPPLY VOLTAGE: 9V to 20V**
- **DIGITAL SUPPLY: 2V to 5.5V**
- **TWO-WIRE INTERFACE: Supports 400kHz and 3.4MHz Operation**

APPLICATIONS

- **TFT-LCD REFERENCE DRIVERS**

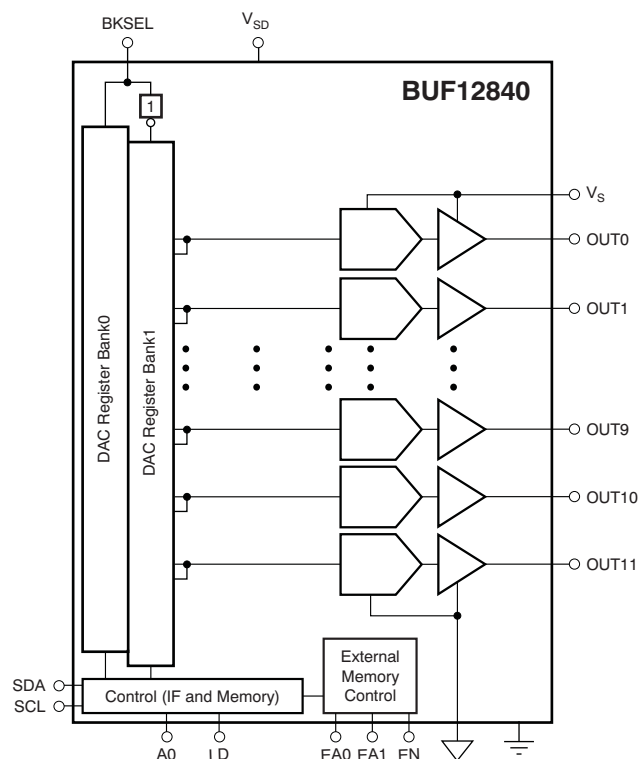

DESCRIPTION

The BUF12840 offers 12 programmable gamma channels with external electrically erasable programmable read-only memory (EEPROM) read capabilities.

The BUF12840 has two separate memory banks that allow simultaneous storage of two different gamma curves to facilitate switching between gamma curves.

All gamma channels offer a rail-to-rail output that typically swings to within 200mV of either supply rail with a 5mA load. All channels are programmed using a two-wire interface that supports standard operations up to 400kHz and high-speed data transfers up to 3.4MHz.

The BUF12840 is manufactured using Texas Instruments' proprietary, state-of-the-art, high-voltage CMOS process. This process offers very dense logic and high supply voltage operation of up to 20V. The BUF12840 is offered in a QFN-24 package, and is specified from -40°C to $+95^{\circ}\text{C}$.

RELATED PRODUCTS

FEATURES	PRODUCT
22-Channel Gamma Correction Buffer	BUF22821
12-Channel Gamma Correction Buffer	BUF12800
20-Channel Programmable Buffer, 10-Bit, V_{COM}	BUF20800
16-/20-Channel Programmable Buffer with Memory	BUF20820
Programmable V_{COM} Driver	BUF01900
18V Supply, Traditional Gamma Buffers	BUF11704
22V Supply, Traditional Gamma Buffers	BUF11705



Please be aware that an important notice concerning availability, standard warranty, and use in critical applications of Texas Instruments semiconductor products and disclaimers thereto appears at the end of this data sheet.

All trademarks are the property of their respective owners.



This integrated circuit can be damaged by ESD. Texas Instruments recommends that all integrated circuits be handled with appropriate precautions. Failure to observe proper handling and installation procedures can cause damage.

ESD damage can range from subtle performance degradation to complete device failure. Precision integrated circuits may be more susceptible to damage because very small parametric changes could cause the device not to meet its published specifications.

PACKAGE/ORDERING INFORMATION⁽¹⁾

PRODUCT	PACKAGE	PACKAGE DESIGNATOR	PACKAGE MARKING	TRANSPORT MEDIA, QUANTITY
BUF12840	VQFN-24	RGE	BUF12840	Tape and Reel, 3000

(1) For the most current package and ordering information, see the Package Option Addendum at the end of this document, or visit the device product folder at ti.com.

ABSOLUTE MAXIMUM RATINGS⁽¹⁾

PARAMETER	BUF12840	UNIT
Supply Voltage V_S	+22	V
Supply Voltage V_{SD}	+6	V
Supply Input Terminals, SCL, SDA, A0, BKSEL, EA0, EA1, EN, LD: Voltage	-0.5 to +6	V
Supply Input Terminals, SCL, SDA, A0, BKSEL, EA0, EA1, EN, LD: Current	±10	mA
Output Short-Circuit ⁽²⁾	Continuous	
Operating Temperature	-40 to +95	°C
Storage Temperature	-65 to +150	°C
Junction Temperature T_J	+125	°C

- (1) Stresses above these ratings may cause permanent damage. Exposure to absolute maximum conditions for extended periods may degrade device reliability. These are stress ratings only, and functional operation of the device at these or any other conditions beyond those specified is not supported.
- (2) Short-circuit to ground. Exposed thermal die is soldered to the PCB using thermal vias. Refer to Texas Instruments application report [QFN/SON PCB Attachment \(SLUS271\)](#).

THERMAL INFORMATION

THERMAL METRIC ⁽¹⁾		BUF12840	UNITS
		RGE	
		24 PINS	
θ_{JA}	Junction-to-ambient thermal resistance	35.6	°C/W
$\theta_{JC(top)}$	Junction-to-case(top) thermal resistance	40.5	
θ_{JB}	Junction-to-board thermal resistance	10.0	
ψ_{JT}	Junction-to-top characterization parameter	0.5	
ψ_{JB}	Junction-to-board characterization parameter	9.9	
$\theta_{JC(bottom)}$	Junction-to-case(bottom) thermal resistance	3.0	

(1) For more information about traditional and new thermal metrics, see the *IC Package Thermal Metrics* application report, [SPRA953](#).

ELECTRICAL CHARACTERISTICS

Boldface limits apply over the specified temperature range, $T_A = -40^\circ\text{C}$ to $+95^\circ\text{C}$.

At $T_A = +25^\circ\text{C}$, $V_S = +18\text{V}$, and $V_{SD} = +5\text{V}$, unless otherwise noted.

PARAMETER	CONDITIONS	BUF12840			UNIT
		MIN	TYP	MAX	
ANALOG GAMMA BUFFER CHANNELS					
Reset value	Code 0		0		V
OUT1 to OUT12 output swing: high	Code = 1023, sourcing 10mA	17.7	17.85		V
OUT1 to OUT12 output swing: low	Code = 0, sinking 10mA		0.07	0.3	V
OUT1 to OUT12 output swing: high	Code = 1023, sourcing 5mA	17.8	17.9		V
OUT1 to OUT12 output swing: low	Code = 0, sinking 5mA		0.07	0.2	V
Continuous output current	See note ⁽¹⁾		30		mA
Output accuracy	Code 512		±20	±50	mV
vs Temperature	Code 512		±25		μV/°C
Integral nonlinearity	INL $V_{OUT} = \text{GND} + 0.3\text{V to } V_S - 0.3\text{V}$		0.3		Bits
Differential nonlinearity	DNL $V_{OUT} = \text{GND} + 0.3\text{V to } V_S - 0.3\text{V}$		0.3		Bits
Load regulation, 10mA	REG Code 512 or $V_{CC}/2$, $I_{OUT} = +5\text{mA to } -5\text{mA}$ step		0.5	1.5	mV/mA
ANALOG POWER SUPPLY					
Operating range		9		20	V
Total analog supply current	I_S Outputs at midscale with no load		6.5	10	mA
Over temperature				19	mA
DIGITAL INPUT/OUTPUT⁽²⁾					
Logic 1 input voltage	V_{IH}	$0.7 \times V_{SD}$			V
Logic 0 input voltage	V_{IL}			$0.3 \times V_{SD}$	V
Logic 0 output voltage	V_{OL} $I_{SINK} = 3\text{mA}$		0.15	0.4	V
Input leakage			±0.01	±10	μA
Clock frequency	f_{CLK}			400	kHz
				3.4	MHz
EEPROM read clock speed	Master mode	71	87	100	kHz
BANK switching delay	LD pin = 0, $V_{OUT} = 50\%$ of code 1023		7	10	μs
DIGITAL POWER SUPPLY					
Operating range	V_{SD}	2.0		5.5	V
Digital supply current ⁽¹⁾	I_{SD} Two-Wire bus inactive		90	150	μA
Over temperature			115	175	μA
Power-on reset	POR	1.1	1.5	1.7	V
TEMPERATURE RANGE					
Specified range		-40		+95	°C
Operating range	Junction temperature < +125°C	-40		+95	°C
Storage range		-65		+150	°C

(1) Observe maximum power dissipation. Exposed thermal die is soldered to the PCB using thermal vias. Refer to Texas Instruments application report [QFN/SON PCB Attachment \(SLUS271\)](#).

(2) Refers to pins EA0, EA1, EN, LD, SCL, SDA, A0, and BKSEL.

PIN CONFIGURATION

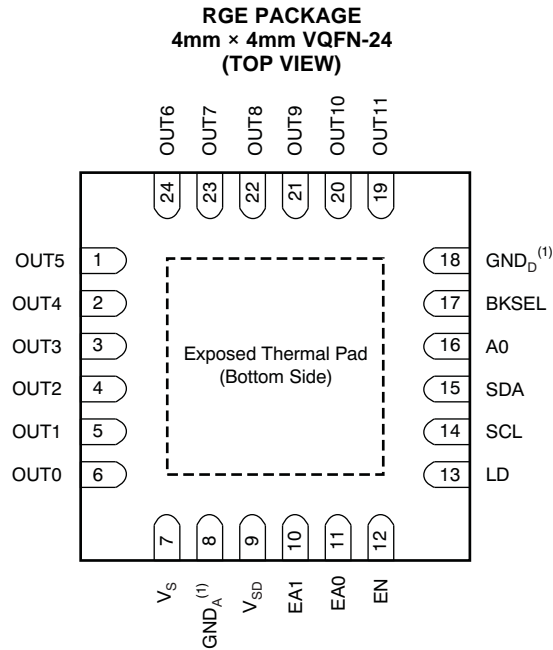

NOTE: (1) GND_A and GND_D must be connected together.

PIN DESCRIPTIONS

PIN NO.	NAME	DESCRIPTION
1	OUT5	DAC output 5
2	OUT4	DAC output 4
3	OUT3	DAC output 3
4	OUT2	DAC output 2
5	OUT1	DAC output 1
6	OUT0	DAC output 0
7	V _S	V _S connected to analog supply
8	GND _A (1)	Analog ground; must be connected to digital ground (GND _D)
9	V _{SD}	Digital supply; connected to logic supply
10	EA1	EEPROM select bit 1. EA1 should be tied to logic '0' if autoread is not used.
11	EA0	EEPROM select bit 0. EA0 should be tied to logic '0' if autoread is not used.
12	EN	EEPROM enable. EN must be '0' if autoread is not used.
13	LD	Latch pin
14	SCL	Serial clock
15	SDA	Serial data
16	A0	Slave address
17	BKSEL	Bank select
18	GND _D	Digital ground; must be connected to digital ground (GND _A)
19	OUT11	DAC output 11
20	OUT10	DAC output 10
21	OUT9	DAC output 9
22	OUT8	DAC output 8
23	OUT7	DAC output 7
24	OUT6	DAC output 6

TYPICAL CHARACTERISTICS

At $T_A = +25^\circ\text{C}$, $V_S = +18\text{V}$, and $V_{SD} = +5\text{V}$, unless otherwise noted.

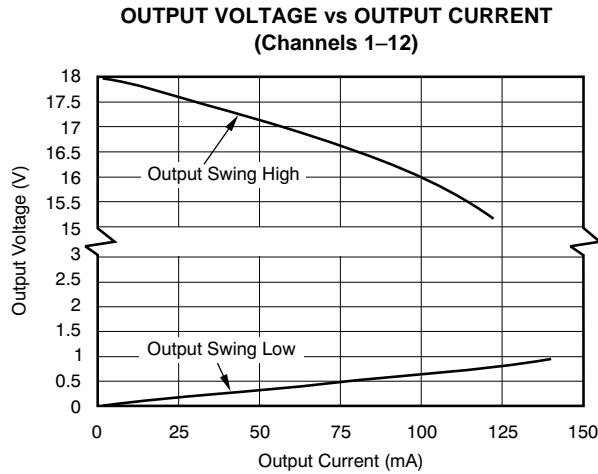

Figure 1.

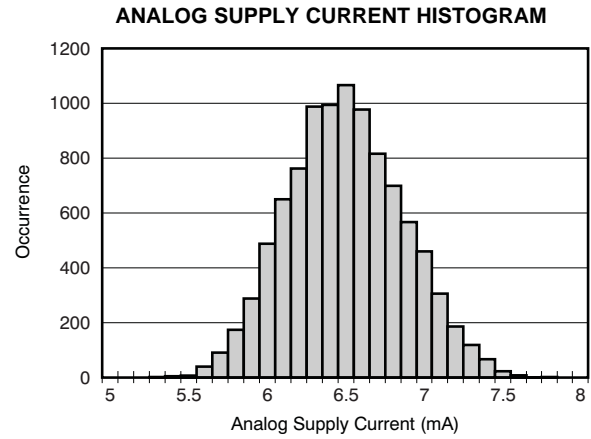

Figure 2.

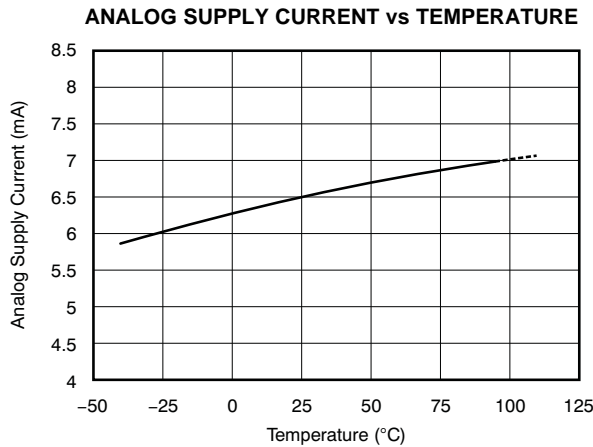

Figure 3.

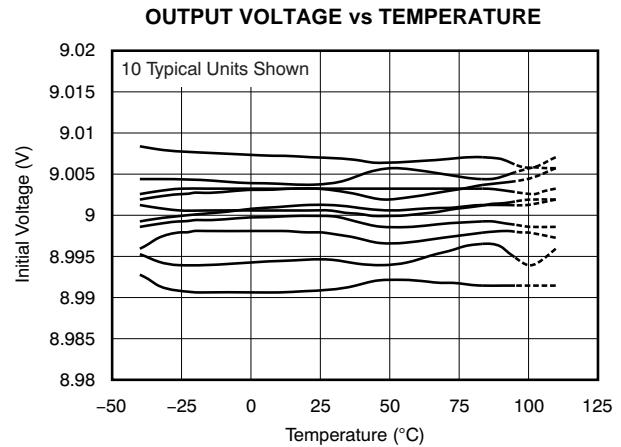

Figure 4.

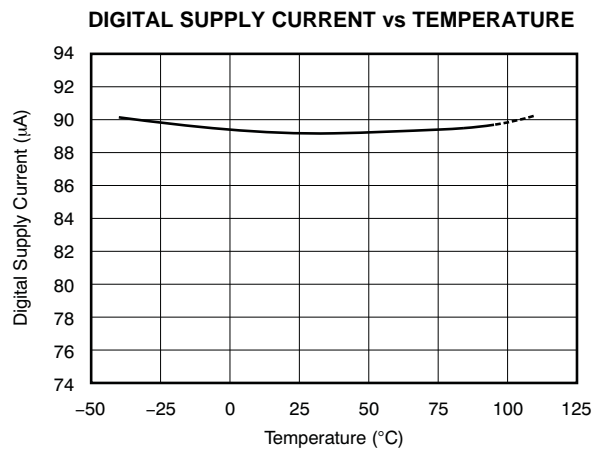

Figure 5.

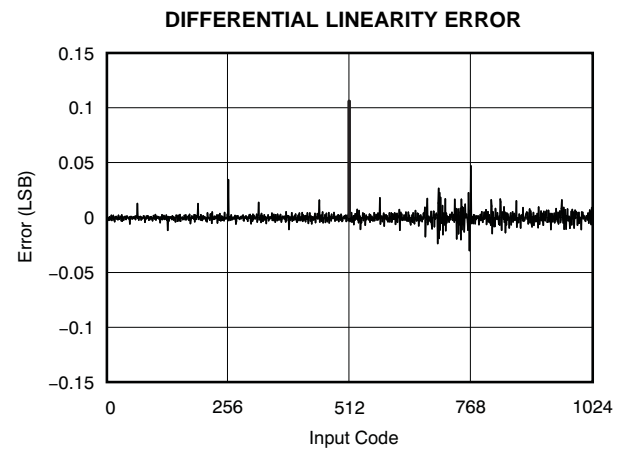

Figure 6.

TYPICAL CHARACTERISTICS (continued)

At $T_A = +25^\circ\text{C}$, $V_S = +18\text{V}$, and $V_{SD} = +5\text{V}$, unless otherwise noted.

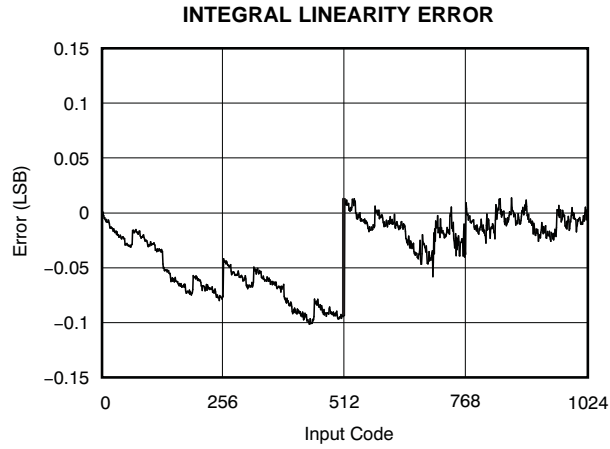

Figure 7.

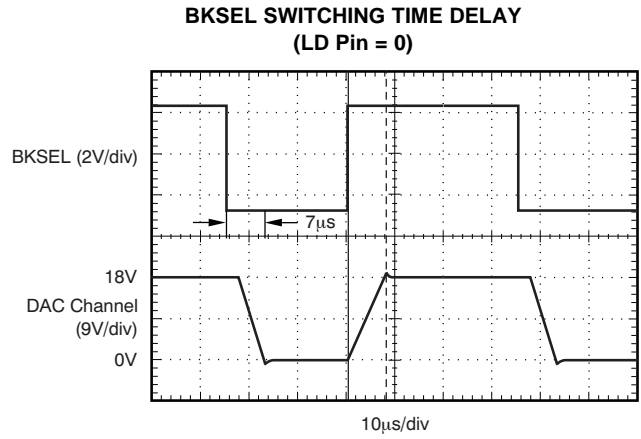

Figure 8.

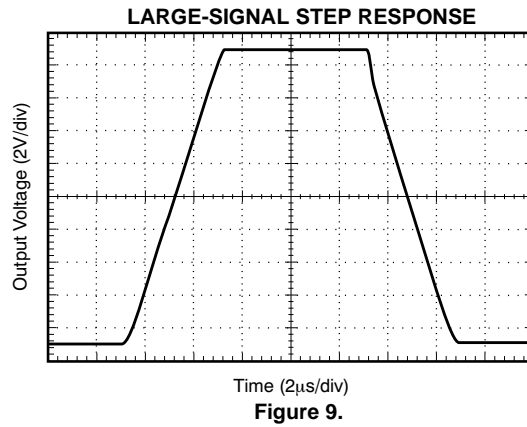

Figure 9.

APPLICATION INFORMATION

GENERAL

The BUF12840 programmable voltage reference allows fast and easy adjustment of 12 programmable gamma reference outputs, each with 10-bit resolution. The BUF12840 is programmed through a high-speed, two-wire interface. The final gamma values can be automatically loaded from an external EEPROM. The BUF12840 has two separate memory banks, allowing simultaneous storage of two different gamma curves to facilitate dynamic switching between gamma curves.

The BUF12840 can be powered using an analog supply voltage from 9V to 20V, and a digital supply from 2V to 5.5V. The digital supply must be applied before the analog supply to avoid excessive current and power consumption, or possibly even damage to the device if left connected only to the analog supply for extended periods of time. See [Figure 10](#) for a typical configuration of the BUF12840. Note that the analog power, V_S , does not need to be on during any interface communication.

TWO-WIRE BUS OVERVIEW

The BUF12840 communicates over an industry-standard, two-wire interface to receive data in slave mode. This model uses a two-wire, open-drain interface that supports multiple devices on a single bus. Bus lines are driven to a logic low level only. The device that initiates the communication is called a *master*, and the devices controlled by the master are *slaves*. The master generates the serial clock on the clock signal line (SCL), controls the bus access, and generates the START and STOP conditions.

To address a specific device, the master initiates a START condition by pulling the data signal line (SDA)

from a high to a low logic level while SCL is high. All slaves on the bus shift in the slave address byte on the rising edge of SCL, with the last bit indicating whether a read or write operation is intended. During the ninth clock pulse, the slave being addressed responds to the master by generating an Acknowledge and pulling SDA low.

Data transfer is then initiated and eight bits of data are sent, followed by an Acknowledge bit. During data transfer, SDA must remain stable while SCL is high. Any change in SDA while SCL is high is interpreted as a START or STOP condition.

Once all data have been transferred, the master generates a STOP condition, indicated by pulling SDA from low to high while SCL is high. The BUF12840 acts as a slave device after 10ms; before that, it is the master and drives SCL and SDA.

ADDRESSING THE BUF12840

The address of the BUF12840 is 111010x, where x is the state of the A0 pin. When the A0 pin is low, the device acknowledges on address 74h (1110100). If the A0 pin is high, the device acknowledges on address 75h (1110101). [Table 1](#) shows the A0 pin settings and the BUF12840 address options.

Other valid addresses are possible through a simple mask change. Contact your TI representative for information.

Table 1. Quick Reference of BUF12840 Addresses

BUF12840 ADDRESS	ADDRESS
A0 pin is low (device acknowledges on address 74h)	1110100
A0 pin is high (device acknowledges on address 75h)	1110101

Table 2. Quick Reference of Command Codes

COMMAND	CODE
General-Call Reset	Address byte of 00h followed by a data byte of 06h.
High-Speed Mode	00001xxx, with SCL ≤ 400kHz; where xxx are bits unique to the Hs-capable master. This byte is called the Hs master code.

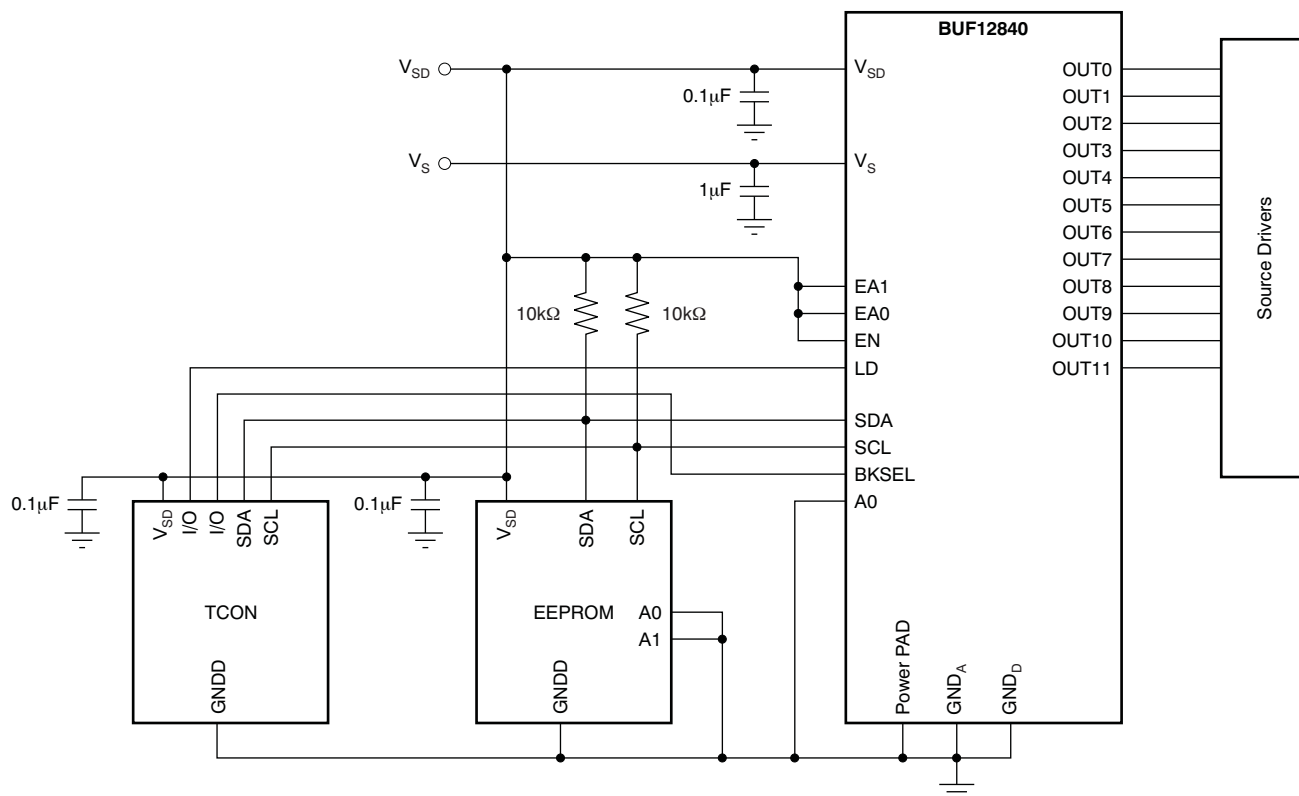

Figure 10. Typical Application Configuration

DATA RATES

The two-wire bus operates in one of three speed modes:

- Standard: allows a clock frequency of up to 100kHz;
- Fast: allows a clock frequency of up to 400kHz; and
- High-speed mode (also called Hs mode): allows a clock frequency of up to 3.4MHz.

The BUF12840 is fully compatible with all three modes. No special action is required to use the device in Standard or Fast modes, but High-speed mode must be activated. To activate High-speed mode, send a special address byte of 00001 xxx, with $SCL \leq 400kHz$, following the START condition; where xxx are bits unique to the Hs-capable master, which can be any value. This byte is called the Hs master

code. Table 2 provides a reference for the High-speed mode command code. (Note that this configuration is different from normal address bytes—the low bit does not indicate read/write status.) The BUF12840 responds to the High-speed command regardless of the value of these last three bits. The BUF12840 does not acknowledge this byte; the communication protocol prohibits acknowledgment of the Hs master code. Upon receiving a master code, the BUF12840 switches on its Hs mode filters, and communicates at up to 3.4MHz. Additional high-speed transfers may be transmitted without resending the Hs mode byte by generating a repeat START without a STOP. The BUF12840 switches out of Hs mode with the next STOP condition.

DAC VOLTAGE OUTPUT CODE

Buffer output values are determined by the analog supply voltage (V_S) and the decimal value of the binary input code used to program that buffer. The value is calculated using Equation 1:

$$V_{OUT} = V_S \times \left(\frac{CODE}{1024} \right)$$

Where:

CODE can vary from 0 to 1023. (1)

The BUF12840 outputs are capable of a full-scale voltage output change in typically 5µs, see Figure 9; no intermediate steps are required. The outputs are also capable of a full-scale output change using the BKSEL or LD pin in typically 7µs, see Figure 8.

SOFTWARE DAC OUTPUT UPDATE

Because the BUF12840 features a double-buffered register structure, updating the digital-to-analog converter (DAC) register is not the same as updating the DAC output voltage. There are two methods for updating the DAC output voltages.

Method 1: Method 1 is used when it is desirable to have the DAC output voltage change immediately after writing to a DAC register. For each write transaction, the master sets data bit 15 to a '1'. The DAC output voltage update occurs after receiving the 16th data bit for the currently-written register, as shown in Figure 11.

Method 2: Method 2 is used when it is desirable to have all DAC output voltages change at the same time. First, the master writes to the desired DAC channels with data bit 15 a '0'. Then, when writing the last desired DAC channel, the master sets data bit 15 to a '1'. All DAC channels are updated at the same time after receiving the 16th data bit.

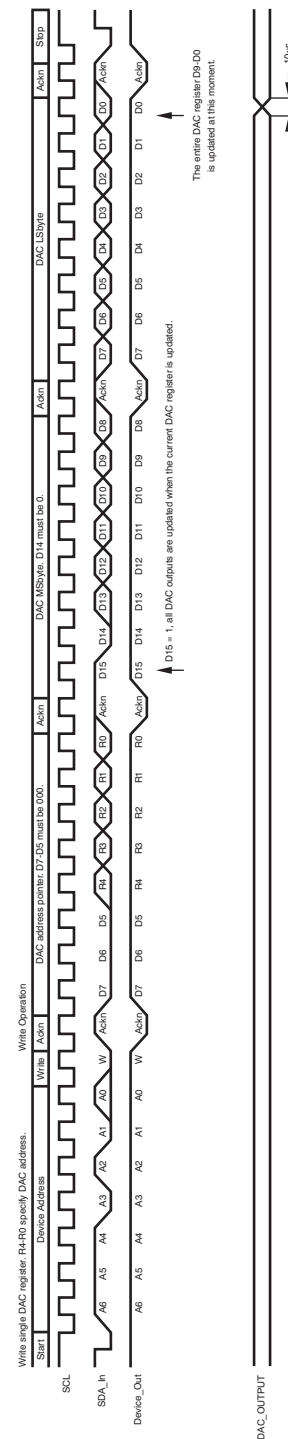

Figure 11. Write DAC_OUT Register Timing

EEPROM ADDRESS SELECT PINS

EA0 and EA1 are used to select the proper EEPROM size. Table 4 shows the start and stop address to load each of the DAC registers. The state of the select pins must be set before the auto read function is activated.

Enable Pin

The status of EN at power-on reset (POR) determines the modes of operation of the BUF12840, as described in Table 3. If EN = 1, the BUF12840 acts as a master; after the data download finishes, the BUF12840 enters slave mode. If EN = 0, the BUF12840 skips the master mode and enters slave mode directly. Once in slave mode after POR, changing the status of EN has no effect on the BUF12840 unless the user issues a GCR (general-call reset) or RA (read again) command.

Table 3. EN Modes of Operation

ENABLE EN	LOGIC LEVEL	EEPROM AUTO READ
Low	0	Disabled
High	1	Enabled

After a POR condition is detected by the BUF12840, a 10ms window occurs. As long as EN goes high in this window, the BUF12840 downloads data from the EEPROM. It is recommended that this pin be tied to DVDD if the application allows. However, if only slave

mode operation is needed, EN should be tied to DVSS; it is recommended that after POR occurs wait at least 15ms before addressing the BUF12840. Figure 12 shows how EN affects the operation of the BUF12840 in a typical application.

The BUF12840 tries to read up to 10 times spaced 1ms apart during POR, which can occur if the EEPROM is not ready or if the two-wire bus is kept busy by another device. By the end of the tenth attempt, if the download cannot be started, the BUF12840 goes into slave mode. This action ensures that the BUF12840 enters slave mode within 25ms from the POR condition, regardless if the download is successful or not.

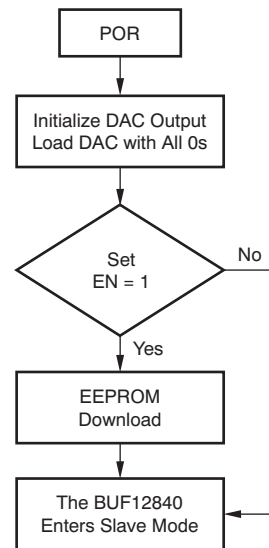

Figure 12. Effect of EN in a Typical Set Up

Table 4. EEPROM Configuration

EA0	EA1	REGISTER BANK0		REGISTER BANK1		ACCEPTABLE EEPROM ⁽¹⁾⁽²⁾
		START WORD ADDRESS	END WORD ADDRESS	START WORD ADDRESS	END WORD ADDRESS	
0	0	0	23	24	47	1k, 2k, 4k, 8k, 16k
0	1	361	384	405	428	2k, 4k, 8k, 16k
1	0	0	23	24	47	32k, 64k, 128k, 256k and larger
1	1	361	384	405	428	32k, 64k, 128k, 256k and larger

- (1) Any applicable EEPROM chip select pins (A2, A1, A0) must be hardwired to GND.
- (2) When EA0 = 0 and EA1 = 1, it is required that the types of EEPROM that supports Page/Block address definition with chip select pins (for example, A0 is part of the Word Address).

POWER-ON RESET (POR) AUTO READ FUNCTION

Figure 14 depicts the BUF12840 POR Master Mode auto read function and timing. The BUF12840 makes the first attempt to read the external EEPROM 5ms after the POR (power-on reset) condition is met, as shown in Figure 13. Following the initial 5ms wait period, the BUF12840 queries the EEPROM with a digital word that includes an EEPROM address and acknowledge request. If communication with the EEPROM is established, the download finishes in 10ms.

However, if the first read attempt is not successful, the BUF12840 waits for 1ms and then tries to start the download again. This process repeats itself until a successful acknowledge from the EEPROM is detected or until 10 read attempts have been made. If at any time during this process the BUF12840 does detect a successful acknowledge from the EEPROM and the EN pin is properly set, the BUF12840 initiates the upload and reads the contents of the EEPROM, which takes approximately 10ms to complete. The DAC output power-on reset value is 0V. The state of V_S (analog supply voltage) does not affect POR or the auto read function.

Immediately after power up, all DAC outputs are set to 0V. During the auto-read function, values are written into the DAC registers as they are being read from the EEPROM. Once the auto-read function is complete, all values are simultaneously loaded from the DAC registers to the DAC outputs. Therefore, all values change together. This action is performed regardless of the state of the LD pin and occurs by default after auto-read is completed.

Once the information is downloaded from the EEPROM, the BUF12840 automatically goes into slave mode, where all slave mode operations are supported. The BUF12840 remains in slave mode until another POR, GCR (general-call reset), or RA (read again) condition is met.

The EN pin should be set to a high level within 15ms of crossing the POR condition. If the EN pin active high state is not detected during the first 10 query attempts, the BUF12840 automatically enters slave mode. If the master mode auto read function must be terminated at any time during the auto read process, the EN pin can be set to a low '0' level that forces the BUF12840 into slave mode and the automatic download process to stop. If an EEPROM acknowledge is not detected during the possible 10 read attempts, the BUF12840 automatically goes into slave mode following the tenth read attempt. Note that the analog power, V_S , does not need to be on during any interface communication.

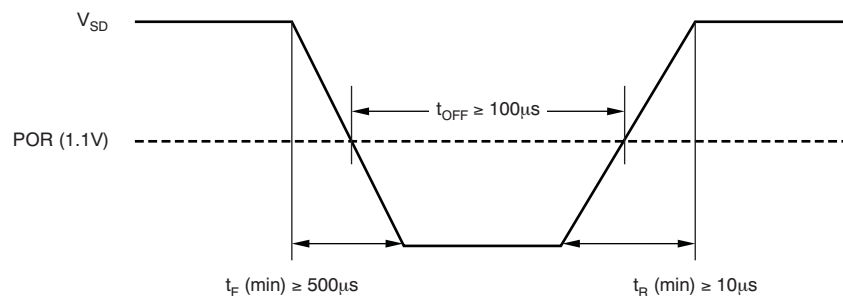

Figure 13. POR

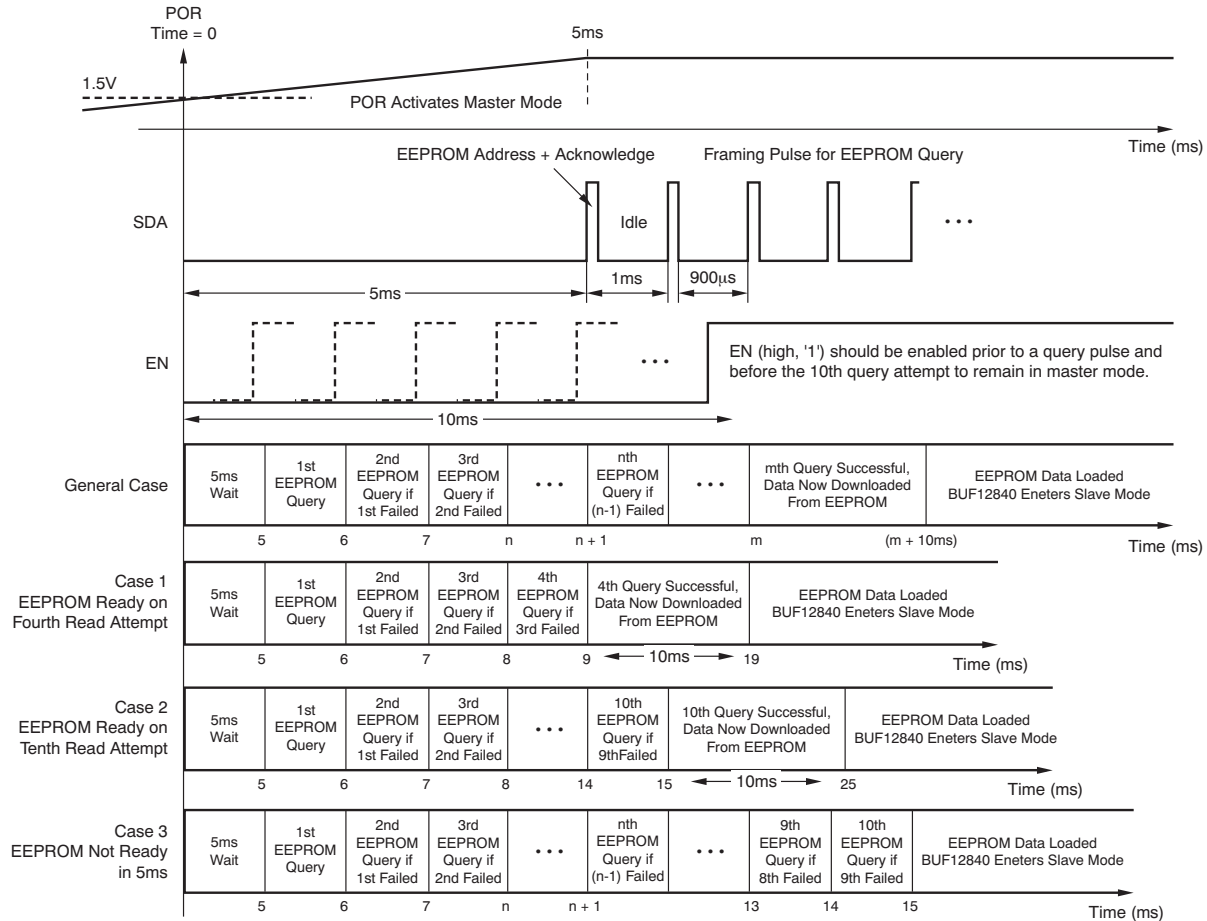

Figure 14. POR Master Mode Auto Read Function and Timing Diagram

MASTER MODE CLOCK SPEED

In master mode, the BUF12840 generates its own clock and puts it on the SCL pin. The frequency is nominally 87kHz, with a maximum value of 100kHz and a minimum value of 71kHz. When the BUF12840 has exclusive access to the two-wire bus, it takes a maximum of 10ms to download both banks of data from the moment power becomes valid. However, when the BUF12840 is in master mode, if there is contention on the two-wire bus because of another active master, the BUF12840 activates its clock synchronization and arbitration engine. In this case, it may take longer for the BUF12840 to finish the download.

The BUF12840 can only synchronize with other masters that operate in Standard Mode (clock speed ≤ 100kHz). It is not recommended to have another master with higher speed operating at the same time. Note that once in slave mode, the BUF12840 supports clock speeds up to 3.4MHz.

GENERAL-CALL RESET

The BUF12840 responds to software general-call reset (GCR). Upon receiving a GCR command, the BUF12840 enters master mode and downloads data from the EEPROM as if the power supply was just switched on.

READ AGAIN

When the BUF12840 is in slave mode, a read again (RA) command can be issued to restart an EEPROM data download. The RA command follows this process:

1. Send the BUF12840 device address with write bit: *11101000* if A0 = 0 or *11101010* if A0 = 1; the BUF12840 acknowledges this byte.
2. Send register address *00011100*; the BUF12840 acknowledges this byte.
3. Send two bytes of data *xxxxxxx* and *xxxxxxx1*, where *x* is *don't care*; the BUF12840 acknowledges both bytes.

DAC OUTPUT UPDATE (Using the LD Pin)

Because the BUF12840 features a double-buffered register structure, updating the **DAC register** is not the same as updating the **DAC output voltage**. There are three methods for launching transferred data from the storage registers into the DACs to update the DAC output voltage. It is essential that BKSEL be set to the desired bank because BKSEL determines which bank is loaded.

Method 1: Set the latch pin low (LD = low) to update each DAC output voltage whenever its corresponding register is updated.

Method 2: Set LD high to allow all DAC output voltages to retain the respective values during data transfer until LD goes low, which simultaneously updates the output voltages of all 12 DACs to the new register values.

Method 3 (software mode): LD is maintained high and all 12 DACs are updated when the master writes a '1' in bit 15 of any DAC register. The update occurs after receiving the 16-bit data for the currently-written register.

Use methods 2 and 3 to transfer a future data set into the first bank of registers in advance to prepare for a very fast update of DAC output voltages.

The general-call reset (GCR) and the power-up reset updates the DACs regardless of the state of the latch pin. For a list of DAC addresses; see [Table 5](#).

BKSEL PIN

The BUF12840 has the ability to store two distinct gamma curves in two different memory banks. One of the two available banks is selected using the external input pin, BKSEL. When this pin is low, BANK0 is selected; when this pin is high, BANK1 is selected.

The two-wire master also has the ability to update (acquire) the DAC registers with the last programmed nonvolatile memory values using software control. The bank to be acquired depends on the state of BKSEL.

WRITE BOTH BANKS OF DAC REGISTERS

In slave mode, writes to both banks are accomplished through the two-wire bus; there are different register address for the two banks. The BKSEL pin does not impact writing to each of the banks. Table 5 details the DAC addresses for each bank.

DAC_OUT voltages update with the appropriate bank values based on a combination of LD and BKSEL pins.

Case 1: DAC_OUT updates to BANK1 because the LD pin is low and BKSEL is high. **Case 2:** DAC_OUT updates to BANK0 because BKSEL and the LD pin are low. **Case 3:** DAC_OUT does not update when the LD pin is high. **Case 4:** DAC_OUT updates to BANK0 because the LD pin and BKSEL are low. **Case 5:** DAC_OUT updates to BANK1 because the LD pin is low and BKSEL is high.

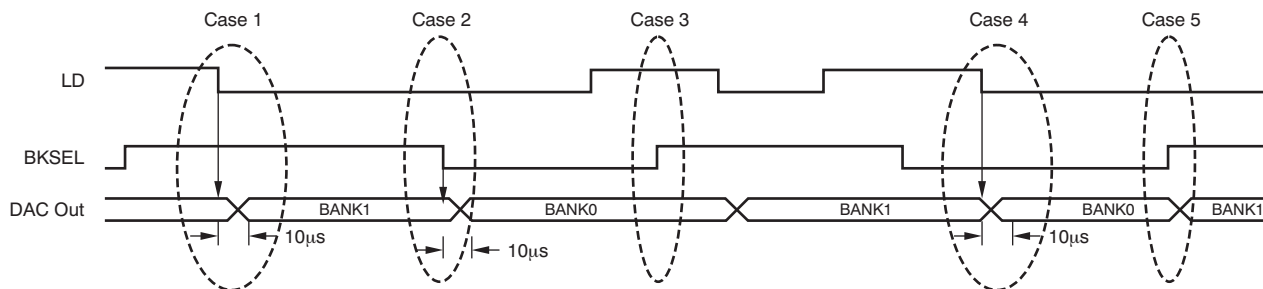

Figure 15. LD/BKSEL Function and DAC Output Timing Diagram

Table 5. BANK0 and BANK1 DAC Addresses

GAMMA BUFFER OUTPUT	BANK0						BANK1					
	REGISTER	R4	R3	R2	R1	R0	REGISTER	R4	R3	R2	R1	R0
OUT0	Register 0 BANK0	0	0	0	0	0	Register 0 BANK1	1	0	0	0	0
OUT1	Register 1 BANK0	0	0	0	0	1	Register 1 BANK1	1	0	0	0	1
OUT2	Register 2 BANK0	0	0	0	1	0	Register 2 BANK1	1	0	0	1	0
OUT3	Register 3 BANK0	0	0	0	1	1	Register 3 BANK1	1	0	0	1	1
OUT4	Register 4 BANK0	0	0	1	0	0	Register 4 BANK1	1	0	1	0	0
OUT5	Register 5 BANK0	0	0	1	0	1	Register 5 BANK1	1	0	1	0	1
OUT6	Register 6 BANK0	0	0	1	1	0	Register 6 BANK1	1	0	1	1	0
OUT7	Register 7 BANK0	0	0	1	1	1	Register 7 BANK1	1	0	1	1	1
OUT8	Register 8 BANK0	0	1	0	0	0	Register 8 BANK1	1	1	0	0	0
OUT9	Register 9 BANK0	0	1	0	0	1	Register 9 BANK1	1	1	0	0	1
OUT10	Register 10 BANK0	0	1	0	1	0	Register 10 BANK1	1	1	0	1	0
OUT11	Register 11 BANK0	0	1	0	1	1	Register 11 BANK1	1	1	0	1	1

TIMING DIAGRAMS

Figure 16 describes the timing operations on the BUF12840. Parameters for Figure 16 are defined in Table 6. Bus definitions are:

Bus Idle: Both SDA and SCL lines remain high.

Start Data Transfer: A change in the state of the SDA line, from high to low, while the SCL line is high, defines a START condition. Each data transfer is initiated with a START condition, denoted as *S* in Figure 16.

Stop Data Transfer: A change in the state of the SDA line from low to high while the SCL line is high defines a STOP condition. Each data transfer terminates with a repeated START or STOP condition, denoted as *P* in Figure 16.

Data Transfer: The number of data bytes transferred between a START and a STOP condition is not limited and is determined by the master device. The receiver acknowledges data transfer.

Acknowledge: Each receiving device, when addressed, is obliged to generate an Acknowledge bit. A device that acknowledges must pull down the SDA line during the Acknowledge clock pulse in such a way that the SDA line is stable low during the high period of the Acknowledge clock pulse. Setup and hold times must be taken into account. On a master receive, data transfer termination can be signaled by the master generating a Not-Acknowledge on the last byte that has been transmitted by the slave.

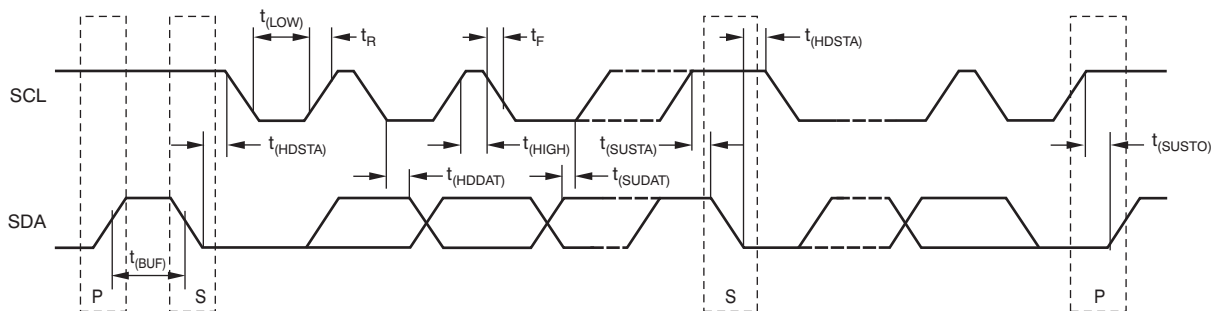

Figure 16. Two-Wire Timing Diagram

Table 6. Timing Characteristics for Figure 16

PARAMETER		STANDARD MODE		FAST MODE		HIGH-SPEED MODE		UNITS
		MIN	MAX	MIN	MAX	MIN	MAX	
SCL operating frequency	$f_{(SCL)}$	0	0.1	0	0.4	0	3.4	MHz
Bus free time between STOP and START condition	$t_{(BUF)}$	4000		600		160		ns
Hold time after repeated START condition. After this period, the first clock is generated.	$t_{(HDSTA)}$	100		100		100		ns
Repeated START condition setup time	$t_{(SUSTA)}$	100		100		100		ns
STOP condition setup time	$t_{(SUSTO)}$	100		100		100		ns
Data hold time	$t_{(HDDAT)}$	1 ⁽¹⁾		0 ⁽¹⁾		0 ⁽²⁾		ns
Data setup time	$t_{(SUDAT)}$	250		100		10		ns
SCL clock low period	$t_{(low)}$	4700		1300		160		ns
SCL clock high period	$t_{(high)}$	4000		600		60		ns
Clock/data fall time	t_F		300		300		160	ns
Clock/data rise time	t_R		300		300		160	ns
for SCLK ≤ 100kHz			1000		1000			ns

(1) For cases with a fall time of SCL less than 20ns and/or the rise time or fall time of SDA less than 20ns, the hold time should be greater than 20ns.

(2) For cases with a fall time of SCL less than 10ns and/or the rise or fall time of SDA less than 10ns, the hold time should be greater than 10ns.

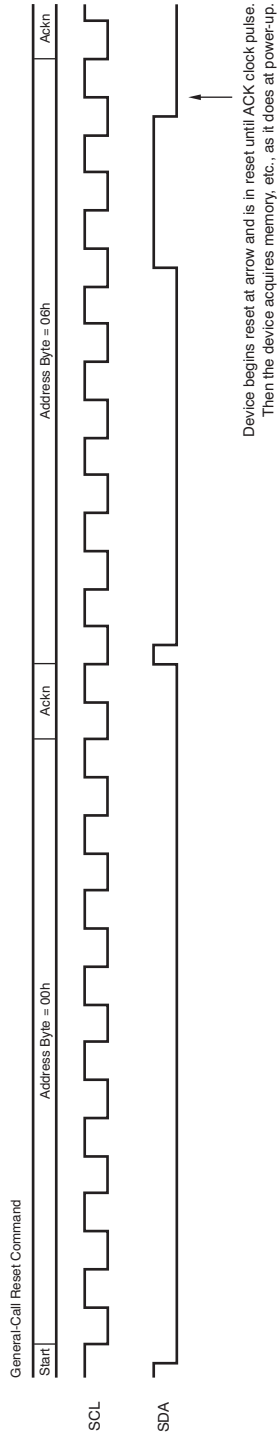

Figure 17. General-Call Reset Timing

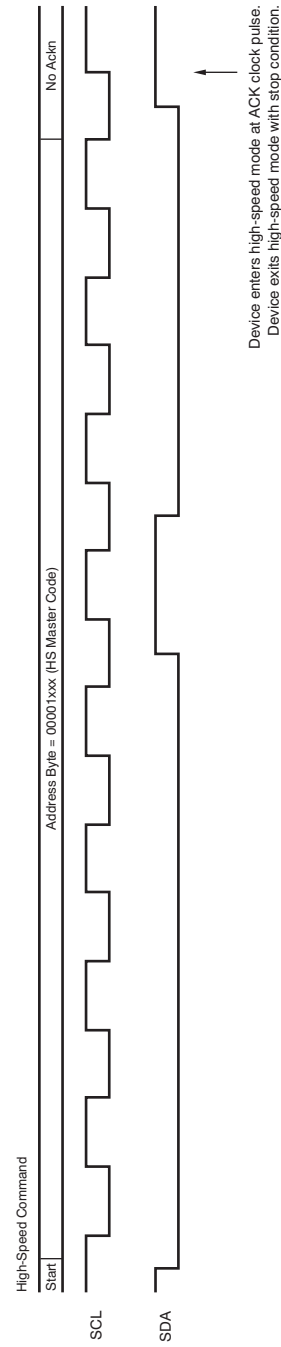

Figure 18. High-Speed Mode Timing

DYNAMIC GAMMA CONTROL

Dynamic gamma control is a technique used to improve the picture quality in LCD TV applications. The brightness in each picture frame is analyzed and the gamma curves are adjusted on a frame-by-frame basis. The gamma curves are typically updated during the short vertical blanking period in the video signal. Figure 19 shows a block diagram using the BUF12840 for dynamic gamma control.

The BUF12840 is ideally suited for rapidly changing the gamma curves as a result of its unique topology:

- Double register input structure to the DAC
- Fast serial interface
- Simultaneous updating of all DACs by software. See the [Read/Write Operations](#) section to write to all registers and the [Output Latch](#) sections.

END-USER SELECTED GAMMA CONTROL

The double register input structure saves programming time by allowing updated DAC values to be pre-stored into the first register bank. Storage of this data can occur while a picture is still being displayed. Because the data are only stored into the first register bank, the DAC output values remain unchanged—the display is unaffected. During the vertical sync period, the DAC outputs (and therefore, the gamma voltages) can be quickly updated either

by using an additional control line connected to the LD pin, or through software—writing a '1' in bit 15 of any DAC register. For details on the operation of the double register input structure, see the [Output Latch](#) section.

Example: Update all 12 registers simultaneously via software.

Step 1: Check if the LD pin is placed in a high state.

Step 2: Write DAC registers 1-12 with bit 15 always '0'.

Step 3: Write any DAC register a second time with identical data. Make sure that bit 15 is '1'. All DAC channels are updated simultaneously after receiving the last bit of data.

Example: Update all 12 registers simultaneously via hardware.

Step 1: Toggle the BKSEL pin to the desired gamma curve, either Bank0 or Bank1.

Step 2: Toggle the LD pin low. When this occurs, all 12 internal DAC registers are updated after 1 μ s. The output then slews to the new voltage level. The time to change between two gamma voltage settings is then dependent on the slew rate of the DAC plus the gamma buffer and the change in voltage required. This value can be obtained by referring to the *Large-Signal Step Response* curve (Figure 9).

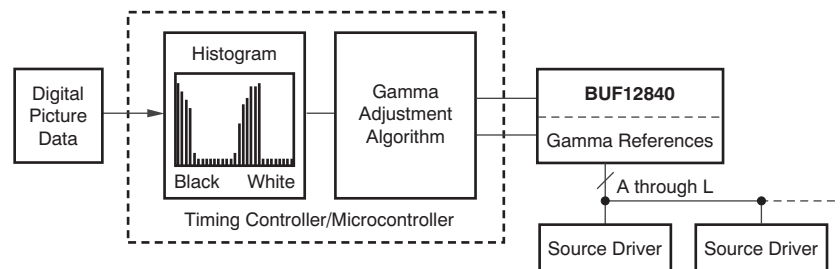

Figure 19. Dynamic Gamma Control

READ/WRITE OPERATIONS

The BUF12840 is able to read from a single DAC or multiple DACs, or write to the register of a single DAC, or multiple DACs in a single communication transaction. DAC addresses for BANK0 begin with 00000, which corresponds to Register 0, through 01011, which corresponds to Register 11. DAC addresses for BANK1 begin with 10000, which corresponds to Register 0, through 11011, which corresponds to Register 11; see [Table 5](#). Write commands are performed by setting the read/write bit LOW. Setting the read/write bit HIGH performs a read transaction.

Writing

To write to a single DAC register:

1. Send a START condition on the bus.
2. Send the device address and read/write bit = LOW. The BUF12840 acknowledges this byte.
3. Send a DAC address byte. Bits D7–D5 are unused and should be set to 0. Bits D4–D0 are the DAC address; see [Table 5](#). Only DAC addresses 00000 to 01011 and 10000 to 11011 are valid and acknowledged.
4. Send two bytes of data for the specified DAC. Begin by sending the most significant byte first (bits D15–D8, of which only bits D9 and D8 are used), followed by the least significant byte (bits D7–D0). The DAC register is updated after receiving the second byte.
5. Send a STOP condition on the bus.

See [Figure 20](#).

The BUF12840 acknowledges each data byte. If the master terminates communication early by sending a STOP or START condition on the bus, the specified register is not updated. Updating the DAC register is not the same as updating the DAC output voltage; see the [Output Latch](#) section.

The process of updating multiple registers begins the same as when updating a single register. However, instead of sending a STOP condition after writing the addressed register, the master continues to send data for the next register. The BUF12840 automatically and sequentially steps through subsequent registers as additional data are sent. The process continues until all desired registers have been updated or a STOP condition is sent.

To write to multiple registers:

1. Send a START condition on the bus.
2. Send the device address and read/write bit = LOW. The BUF12840 acknowledges this byte.
3. Send either the Register 0 address byte to start at the first DAC or send the address of whichever DAC is the first to be updated. The BUF12840 begins with this DAC and steps through subsequent DACs in sequential order.
4. Send the bytes of data. The first two bytes are for the DAC addressed in step 3. Its register is automatically updated after receiving the second byte. The next two are for the following DAC. The DAC register is updated after receiving the fourth byte. The last two bytes are for Register 11. The DAC register is updated after receiving the 24th byte. For each DAC, begin by sending the most significant byte (bits D15–D8, of which only bits D9 and D8 have meaning), followed by the least significant byte (bits D7–D0).
5. Send a STOP condition on the bus.

See [Figure 21](#).

When the DAC registers are written through a two-wire communication, changing the BKSEL pin does not affect the communication because the banks have different addresses. However, when loading the DACs through an I²C communication, the bank to be loaded is decided by the BKSEL pin. Therefore, if the BKSEL pin is switched during a two-wire load, the new value of BKSEL determines the bank that is loaded.

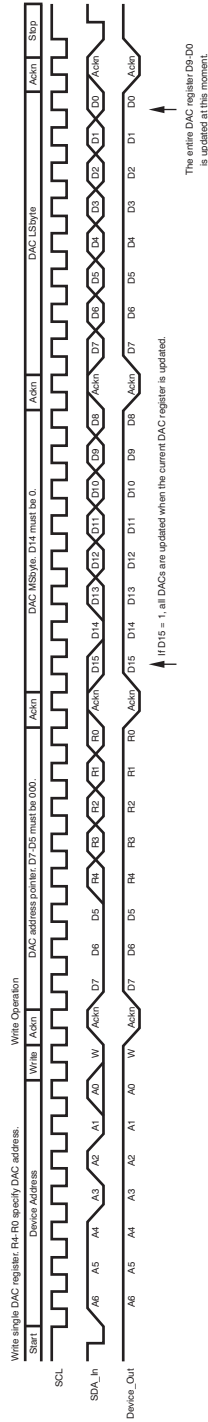

Figure 20. Write Single DAC Register Timing

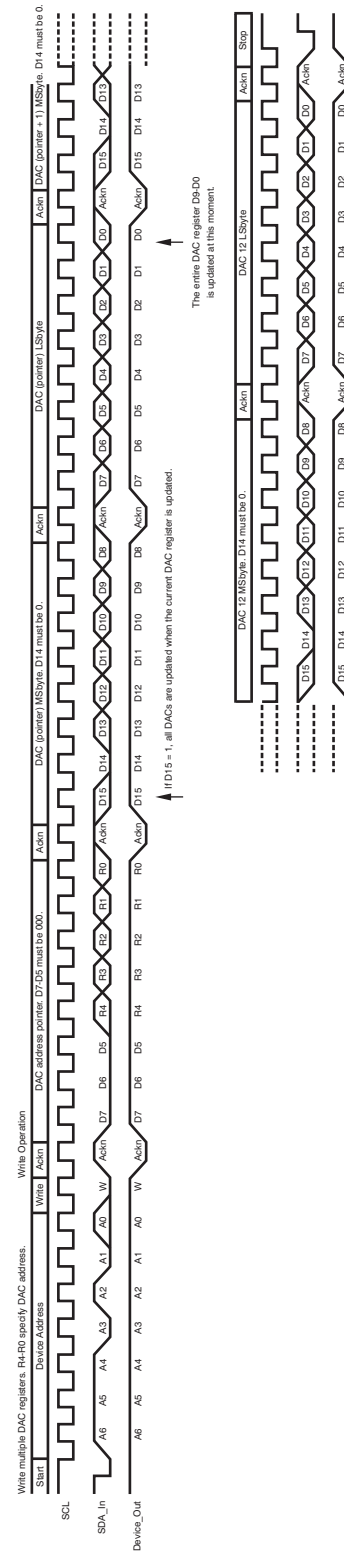

Figure 21. Write Multiple DACs Register Timing

The BUF12840 acknowledges each byte. To terminate communication, send a STOP or START condition on the bus. Only DACs that have received both bytes are updated.

Reading

To read the register of one DAC:

1. Send a START condition on the bus.
2. Send the device address and read/write bit = LOW. The BUF12840 acknowledges this byte.
3. Send a DAC address byte. Bits D7–D5 are unused and should be set to 0. Bits D4–D0 are the DAC address; see [Table 5](#). Only DAC addresses 00000 to 01011 and 10000 to 11011 are valid and acknowledged.
4. Send a START or STOP/START condition on the bus.
5. Send correct device address and read/write bit = HIGH. The BUF12840 acknowledges this byte.
6. Receive two bytes of data. They are for the specified DAC. The first received byte is the most significant byte (bits D15–D8, of which only bits D9 and D8 have meaning); the next is the least significant byte (bits D7–D0).
7. Acknowledge after receiving each byte.
8. Send a STOP condition on the bus.

See [Figure 22](#).

Communication may be terminated by sending a premature STOP or START condition on the bus, or by not sending the acknowledge.

To read multiple DAC registers:

1. Send a START condition on the bus.
2. Send the device address and read/write bit = LOW. The BUF12840 acknowledges this byte.
3. Send either the Register 0 address byte to start at the first DAC or send the address byte for whichever DAC is the first in the sequence of DACs to be read. The BUF12840 begins with this DAC and steps through subsequent DACs in sequential order.
4. Send the device address and read/write bit = HIGH.
5. Receive bytes of data. The first two bytes are for the specified DAC. The first received byte is the most significant byte (bits D15–D8, of which only bits D9 and D8 have meaning). The next byte is the least significant byte (bits D7–D0).
6. Acknowledge after receiving each byte.
7. When all desired DACs have been read, send a STOP or START condition on the bus.

See [Figure 23](#).

Communication may be terminated by sending a premature STOP or START condition on the bus, or by not sending the acknowledge.

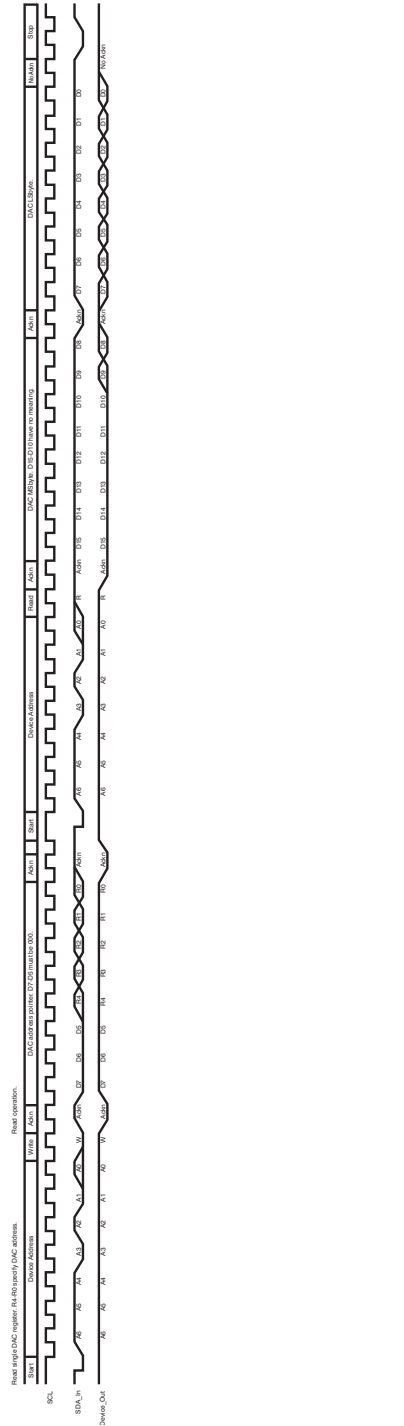

Figure 22. Read Single Register Timing

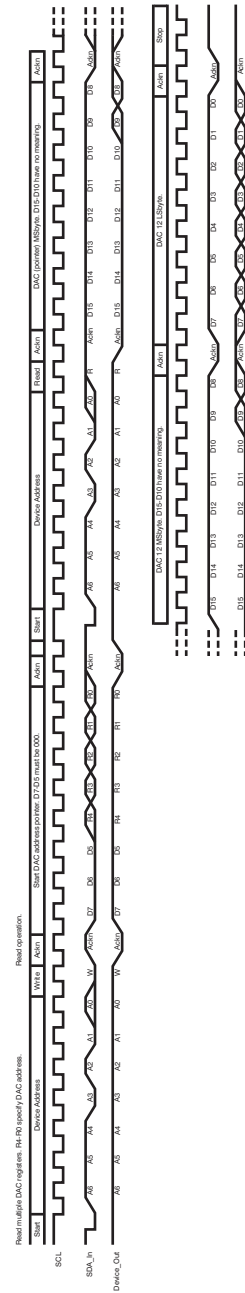

Figure 23. Read Multiple DACs Register Timing

OUTPUT PROTECTION

The BUF12840 output stages can safely source and sink the current levels indicated in Figure 1. However, there are other modes where precautions must be taken to prevent to the output stages from being damaged by excessive current flow. The outputs (OUT1 through OUT12) include electrostatic discharge (ESD) protection diodes, as shown in Figure 24. Normally, these diodes do not conduct and are passive during typical device operation. Unusual operating conditions can occur where the diodes may conduct, potentially subjecting them to high, even damaging current levels. These conditions are most likely to occur when a voltage applied to an output exceeds $(V_S) + 0.5V$, or drops below $GND - 0.5V$.

One common scenario where this condition can occur is when the output pin is connected to a sufficiently large capacitor, and the BUF12840 power-supply source (V_S) is suddenly removed. Removing the power-supply source allows the capacitor to discharge through the current-steering diodes. The energy released during the high current flow period causes the power dissipation limits of the diode to be exceeded. Protection against the high current flow may be provided by placing a Schottky diode, as shown in Figure 24. This diode must be capable of discharging the capacitor without allowing more than 0.5V to develop across the internal ESD current-steering diodes. It is not recommended that large capacitors be connected to the output of the gamma buffers.

Figure 25 shows a simplified schematic of the input pins A0, BKSEL, EN, EA0, EA1, and LD. As shown, there are no ESD cells or diodes to supply; therefore, the input to the device can go above supply but must be lower than 6V.

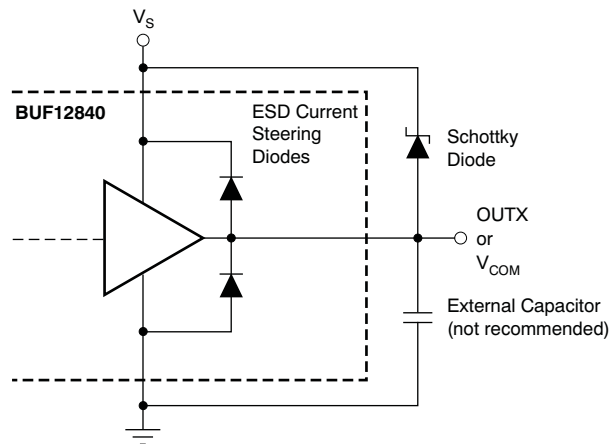

Figure 24. Output Pins ESD Protection Current-Steering Diodes

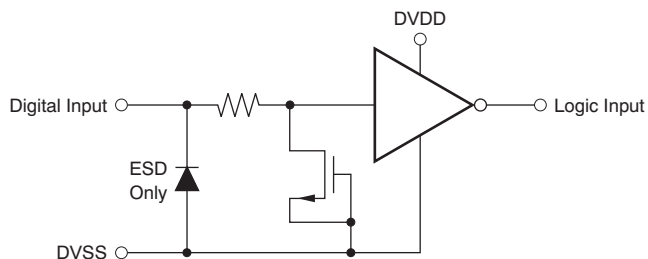

Figure 25. Digital Input Model

Figure 26 shows a simplified schematic of the SDA and SCL input/output pins. As shown, there are no ESD cells or diodes to supply; therefore, the input to the device can go above supply but must be lower than 6V.

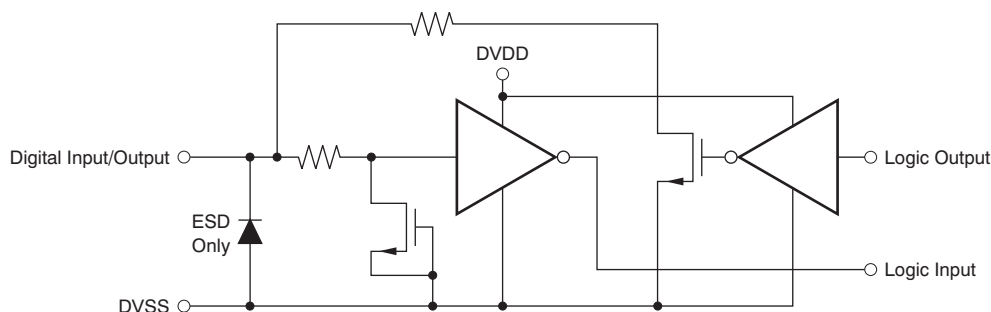

Figure 26. Digital Input/Output Model



REVISION HISTORY

NOTE: Page numbers for previous revisions may differ from page numbers in the current version.

Changes from Original (October, 2010) to Revision A**Page**

-
- Corrected error in x-axis value for [Figure 9](#) 6
-

PACKAGING INFORMATION

Orderable Device	Status (1)	Package Type	Package Drawing	Pins	Package Qty	Eco Plan (2)	Lead/Ball Finish (6)	MSL Peak Temp (3)	Op Temp (°C)	Device Marking (4/5)	Samples
BUF12840AIRGER	ACTIVE	VQFN	RGE	24	3000	Green (RoHS & no Sb/Br)	CU NIPDAU	Level-3-260C-168 HR	-40 to 95	BUF 12840	
BUF12840AIRGET	ACTIVE	VQFN	RGE	24	250	Green (RoHS & no Sb/Br)	CU NIPDAU	Level-3-260C-168 HR	-40 to 95	BUF 12840	

(1) The marketing status values are defined as follows:

ACTIVE: Product device recommended for new designs.

LIFEBUY: TI has announced that the device will be discontinued, and a lifetime-buy period is in effect.

NRND: Not recommended for new designs. Device is in production to support existing customers, but TI does not recommend using this part in a new design.

PREVIEW: Device has been announced but is not in production. Samples may or may not be available.

OBsolete: TI has discontinued the production of the device.

(2) Eco Plan - The planned eco-friendly classification: Pb-Free (RoHS), Pb-Free (RoHS Exempt), or Green (RoHS & no Sb/Br) - please check <http://www.ti.com/productcontent> for the latest availability information and additional product content details.

TBD: The Pb-Free/Green conversion plan has not been defined.

Pb-Free (RoHS): TI's terms "Lead-Free" or "Pb-Free" mean semiconductor products that are compatible with the current RoHS requirements for all 6 substances, including the requirement that lead not exceed 0.1% by weight in homogeneous materials. Where designed to be soldered at high temperatures, TI Pb-Free products are suitable for use in specified lead-free processes.

Pb-Free (RoHS Exempt): This component has a RoHS exemption for either 1) lead-based flip-chip solder bumps used between the die and package, or 2) lead-based die adhesive used between the die and leadframe. The component is otherwise considered Pb-Free (RoHS compatible) as defined above.

Green (RoHS & no Sb/Br): TI defines "Green" to mean Pb-Free (RoHS compatible), and free of Bromine (Br) and Antimony (Sb) based flame retardants (Br or Sb do not exceed 0.1% by weight in homogeneous material)

(3) MSL, Peak Temp. - The Moisture Sensitivity Level rating according to the JEDEC industry standard classifications, and peak solder temperature.

(4) There may be additional marking, which relates to the logo, the lot trace code information, or the environmental category on the device.

(5) Multiple Device Markings will be inside parentheses. Only one Device Marking contained in parentheses and separated by a "~" will appear on a device. If a line is indented then it is a continuation of the previous line and the two combined represent the entire Device Marking for that device.

(6) Lead/Ball Finish - Orderable Devices may have multiple material finish options. Finish options are separated by a vertical ruled line. Lead/Ball Finish values may wrap to two lines if the finish value exceeds the maximum column width.

Important Information and Disclaimer: The information provided on this page represents TI's knowledge and belief as of the date that it is provided. TI bases its knowledge and belief on information provided by third parties, and makes no representation or warranty as to the accuracy of such information. Efforts are underway to better integrate information from third parties. TI has taken and continues to take reasonable steps to provide representative and accurate information but may not have conducted destructive testing or chemical analysis on incoming materials and chemicals. TI and TI suppliers consider certain information to be proprietary, and thus CAS numbers and other limited information may not be available for release.

In no event shall TI's liability arising out of such information exceed the total purchase price of the TI part(s) at issue in this document sold by TI to Customer on an annual basis.

TAPE AND REEL INFORMATION



QUADRANT ASSIGNMENTS FOR PIN 1 ORIENTATION IN TAPE



*All dimensions are nominal

Device	Package Type	Package Drawing	Pins	SPQ	Reel Diameter (mm)	Reel Width W1 (mm)	A0 (mm)	B0 (mm)	K0 (mm)	P1 (mm)	W (mm)	Pin1 Quadrant
BUF12840AIRGER	VQFN	RGE	24	3000	330.0	12.4	4.25	4.25	1.15	8.0	12.0	Q2
BUF12840AIRGET	VQFN	RGE	24	250	180.0	12.4	4.25	4.25	1.15	8.0	12.0	Q2

TAPE AND REEL BOX DIMENSIONS

*All dimensions are nominal

Device	Package Type	Package Drawing	Pins	SPQ	Length (mm)	Width (mm)	Height (mm)
BUF12840AIRGER	VQFN	RGE	24	3000	367.0	367.0	35.0
BUF12840AIRGET	VQFN	RGE	24	250	210.0	185.0	35.0

RGE 24

GENERIC PACKAGE VIEW

VQFN - 1 mm max height

PLASTIC QUAD FLATPACK - NO LEAD

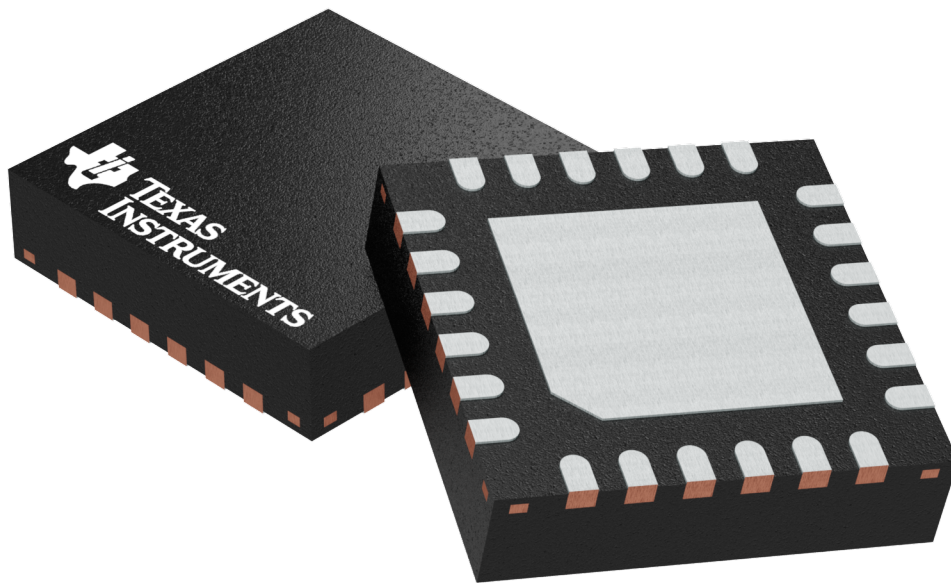

Images above are just a representation of the package family, actual package may vary.
Refer to the product data sheet for package details.

4204104/H

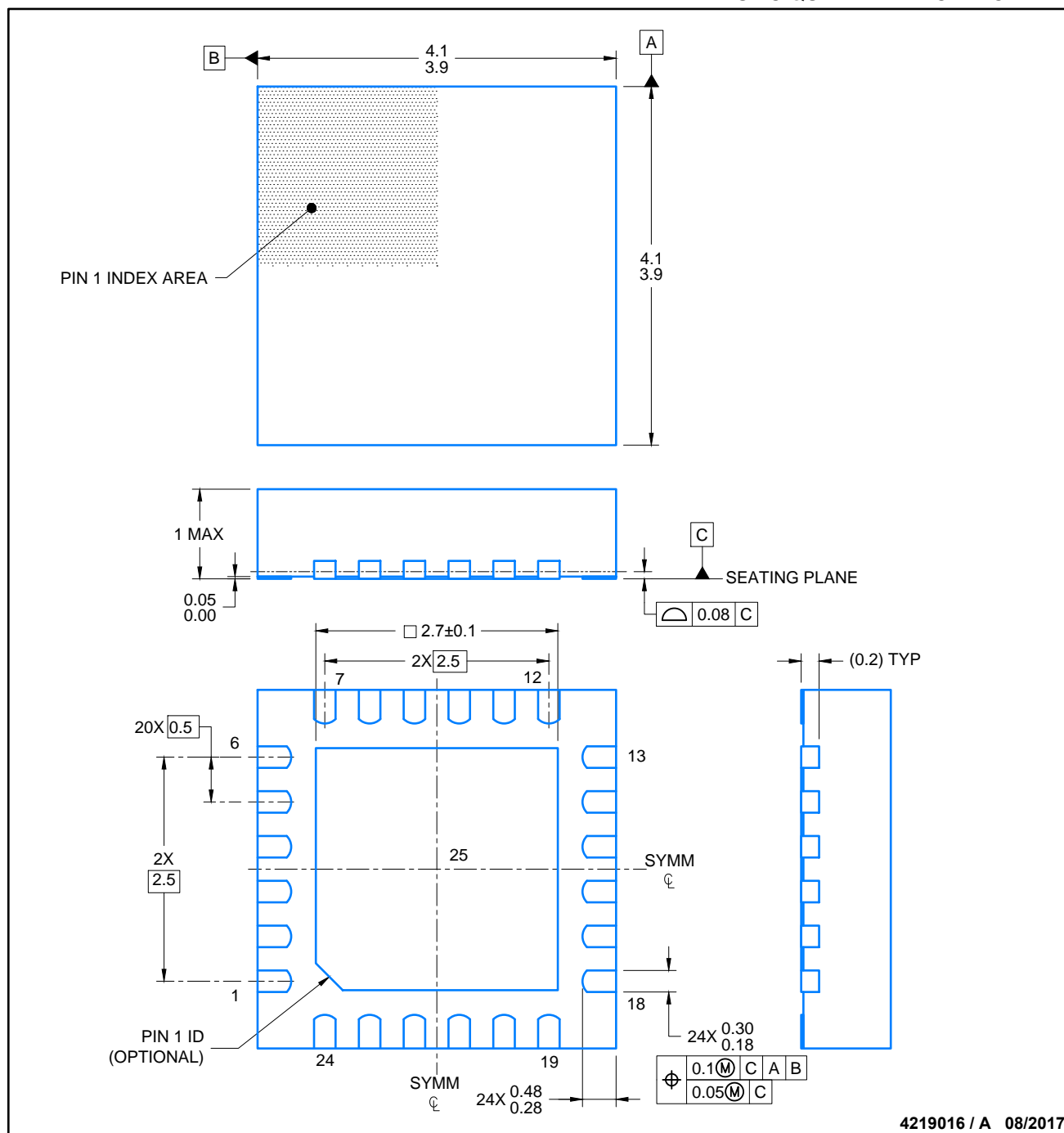

NOTES:

1. All linear dimensions are in millimeters. Any dimensions in parenthesis are for reference only. Dimensioning and tolerancing per ASME Y14.5M.
2. This drawing is subject to change without notice.
3. The package thermal pad must be soldered to the printed circuit board for thermal and mechanical performance.

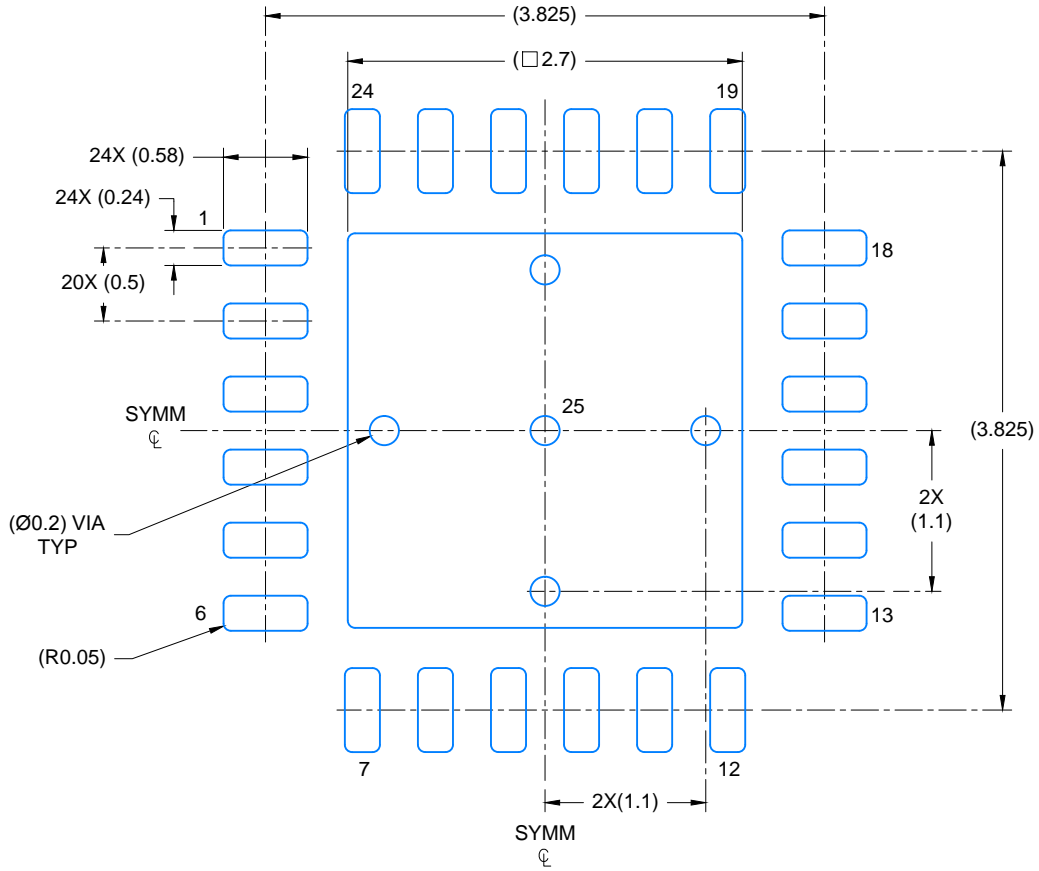

LAND PATTERN EXAMPLE
SCALE: 20X

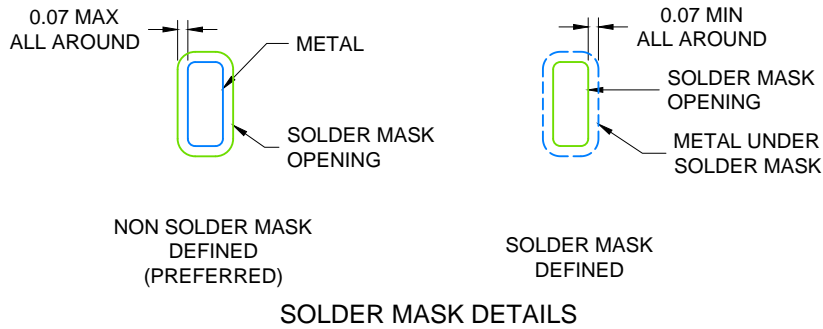

4219016 / A 08/2017

NOTES: (continued)

4. This package is designed to be soldered to a thermal pad on the board. For more information, see Texas Instruments literature number SLUA271 (www.ti.com/lit/slua271).
5. Solder mask tolerances between and around signal pads can vary based on board fabrication site.

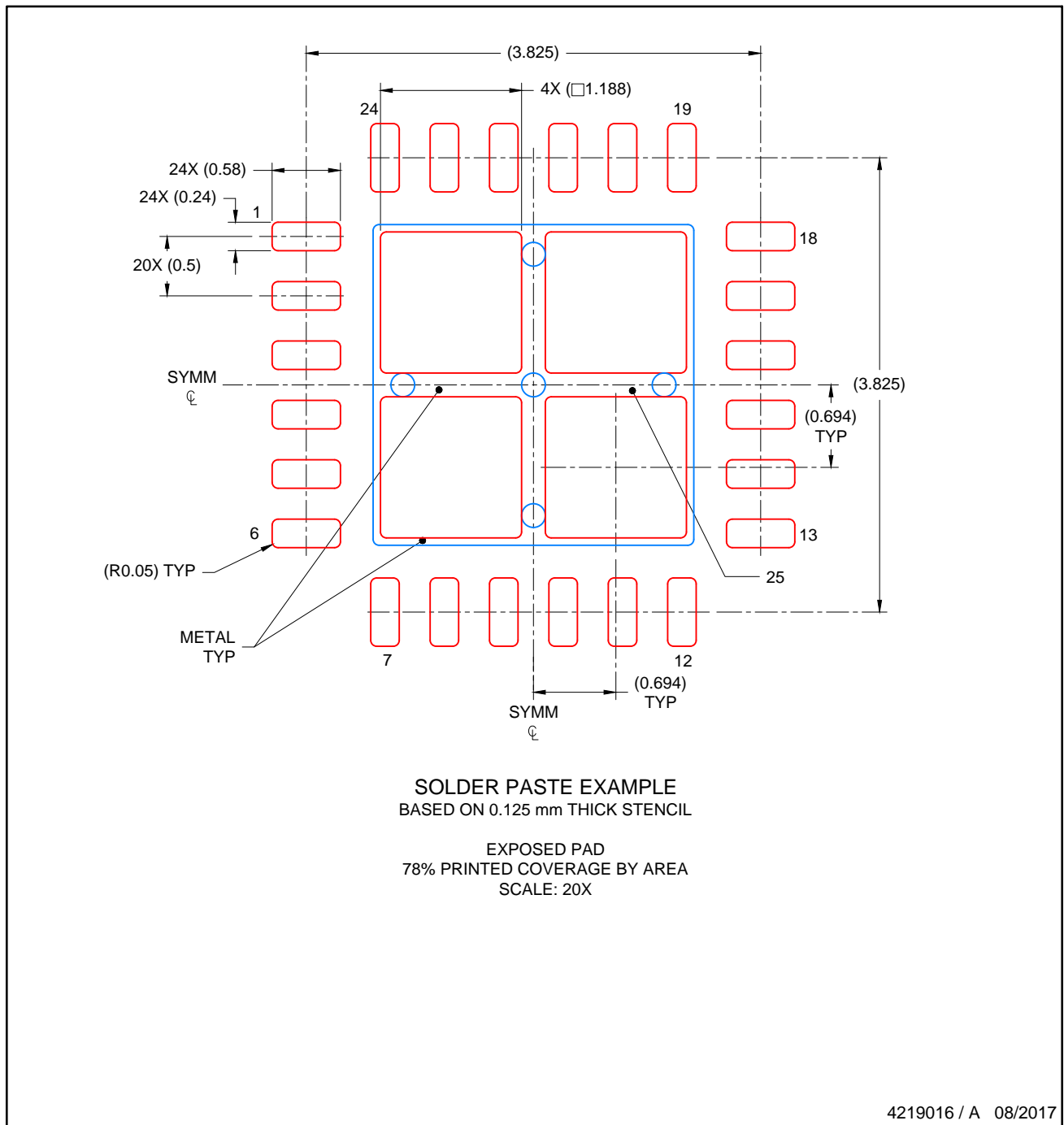

NOTES: (continued)

- 6. Laser cutting apertures with trapezoidal walls and rounded corners may offer better paste release. IPC-7525 may have alternate design recommendations..

IMPORTANT NOTICE

Texas Instruments Incorporated (TI) reserves the right to make corrections, enhancements, improvements and other changes to its semiconductor products and services per JESD46, latest issue, and to discontinue any product or service per JESD48, latest issue. Buyers should obtain the latest relevant information before placing orders and should verify that such information is current and complete.

TI's published terms of sale for semiconductor products (<http://www.ti.com/sc/docs/stdterms.htm>) apply to the sale of packaged integrated circuit products that TI has qualified and released to market. Additional terms may apply to the use or sale of other types of TI products and services.

Reproduction of significant portions of TI information in TI data sheets is permissible only if reproduction is without alteration and is accompanied by all associated warranties, conditions, limitations, and notices. TI is not responsible or liable for such reproduced documentation. Information of third parties may be subject to additional restrictions. Resale of TI products or services with statements different from or beyond the parameters stated by TI for that product or service voids all express and any implied warranties for the associated TI product or service and is an unfair and deceptive business practice. TI is not responsible or liable for any such statements.

Buyers and others who are developing systems that incorporate TI products (collectively, "Designers") understand and agree that Designers remain responsible for using their independent analysis, evaluation and judgment in designing their applications and that Designers have full and exclusive responsibility to assure the safety of Designers' applications and compliance of their applications (and of all TI products used in or for Designers' applications) with all applicable regulations, laws and other applicable requirements. Designer represents that, with respect to their applications, Designer has all the necessary expertise to create and implement safeguards that (1) anticipate dangerous consequences of failures, (2) monitor failures and their consequences, and (3) lessen the likelihood of failures that might cause harm and take appropriate actions. Designer agrees that prior to using or distributing any applications that include TI products, Designer will thoroughly test such applications and the functionality of such TI products as used in such applications.

TI's provision of technical, application or other design advice, quality characterization, reliability data or other services or information, including, but not limited to, reference designs and materials relating to evaluation modules, (collectively, "TI Resources") are intended to assist designers who are developing applications that incorporate TI products; by downloading, accessing or using TI Resources in any way, Designer (individually or, if Designer is acting on behalf of a company, Designer's company) agrees to use any particular TI Resource solely for this purpose and subject to the terms of this Notice.

TI's provision of TI Resources does not expand or otherwise alter TI's applicable published warranties or warranty disclaimers for TI products, and no additional obligations or liabilities arise from TI providing such TI Resources. TI reserves the right to make corrections, enhancements, improvements and other changes to its TI Resources. TI has not conducted any testing other than that specifically described in the published documentation for a particular TI Resource.

Designer is authorized to use, copy and modify any individual TI Resource only in connection with the development of applications that include the TI product(s) identified in such TI Resource. NO OTHER LICENSE, EXPRESS OR IMPLIED, BY ESTOPPEL OR OTHERWISE TO ANY OTHER TI INTELLECTUAL PROPERTY RIGHT, AND NO LICENSE TO ANY TECHNOLOGY OR INTELLECTUAL PROPERTY RIGHT OF TI OR ANY THIRD PARTY IS GRANTED HEREIN, including but not limited to any patent right, copyright, mask work right, or other intellectual property right relating to any combination, machine, or process in which TI products or services are used. Information regarding or referencing third-party products or services does not constitute a license to use such products or services, or a warranty or endorsement thereof. Use of TI Resources may require a license from a third party under the patents or other intellectual property of the third party, or a license from TI under the patents or other intellectual property of TI.

TI RESOURCES ARE PROVIDED "AS IS" AND WITH ALL FAULTS. TI DISCLAIMS ALL OTHER WARRANTIES OR REPRESENTATIONS, EXPRESS OR IMPLIED, REGARDING RESOURCES OR USE THEREOF, INCLUDING BUT NOT LIMITED TO ACCURACY OR COMPLETENESS, TITLE, ANY EPIDEMIC FAILURE WARRANTY AND ANY IMPLIED WARRANTIES OF MERCHANTABILITY, FITNESS FOR A PARTICULAR PURPOSE, AND NON-INFRINGEMENT OF ANY THIRD PARTY INTELLECTUAL PROPERTY RIGHTS. TI SHALL NOT BE LIABLE FOR AND SHALL NOT DEFEND OR INDEMNIFY DESIGNER AGAINST ANY CLAIM, INCLUDING BUT NOT LIMITED TO ANY INFRINGEMENT CLAIM THAT RELATES TO OR IS BASED ON ANY COMBINATION OF PRODUCTS EVEN IF DESCRIBED IN TI RESOURCES OR OTHERWISE. IN NO EVENT SHALL TI BE LIABLE FOR ANY ACTUAL, DIRECT, SPECIAL, COLLATERAL, INDIRECT, PUNITIVE, INCIDENTAL, CONSEQUENTIAL OR EXEMPLARY DAMAGES IN CONNECTION WITH OR ARISING OUT OF TI RESOURCES OR USE THEREOF, AND REGARDLESS OF WHETHER TI HAS BEEN ADVISED OF THE POSSIBILITY OF SUCH DAMAGES.

Unless TI has explicitly designated an individual product as meeting the requirements of a particular industry standard (e.g., ISO/TS 16949 and ISO 26262), TI is not responsible for any failure to meet such industry standard requirements.

Where TI specifically promotes products as facilitating functional safety or as compliant with industry functional safety standards, such products are intended to help enable customers to design and create their own applications that meet applicable functional safety standards and requirements. Using products in an application does not by itself establish any safety features in the application. Designers must ensure compliance with safety-related requirements and standards applicable to their applications. Designer may not use any TI products in life-critical medical equipment unless authorized officers of the parties have executed a special contract specifically governing such use. Life-critical medical equipment is medical equipment where failure of such equipment would cause serious bodily injury or death (e.g., life support, pacemakers, defibrillators, heart pumps, neurostimulators, and implantables). Such equipment includes, without limitation, all medical devices identified by the U.S. Food and Drug Administration as Class III devices and equivalent classifications outside the U.S.

TI may expressly designate certain products as completing a particular qualification (e.g., Q100, Military Grade, or Enhanced Product). Designers agree that it has the necessary expertise to select the product with the appropriate qualification designation for their applications and that proper product selection is at Designers' own risk. Designers are solely responsible for compliance with all legal and regulatory requirements in connection with such selection.

Designer will fully indemnify TI and its representatives against any damages, costs, losses, and/or liabilities arising out of Designer's non-compliance with the terms and provisions of this Notice.

Looking for pricing, stock, or lifecycle information?

Click below to explore more details on WIN SOURCE:

 [View BUF12840AIRGER on WIN SOURCE](#)

 [Texas Instruments](#) Information

Optimize Your Supply Chain with WIN SOURCE Solutions

-  Global Sourcing Solution
-  Obsolete Management
-  Cost Control Management
-  Shortage Management
-  Alternative Solution
-  Excess Inventory Management