



THE DATASHEET OF HSMW-C130



HSMW-C120, HSMW-C130, HSMW-C191, HSMW-C197, HSMW-C265

White ChipLEDs

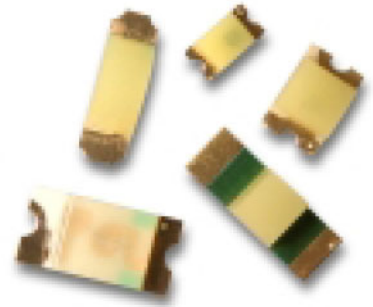

Description

These Broadcom[®] white ChipLEDs come in unique shades of white and provide product differentiation for backlighting applications. They are designed in industry-standard packaging for ease of handling and use.

These chipLEDs come in either a side-emitting package (HSMW-C120) or in top-emitting packages (HSMW-C130, C191, C197, and C265).

The packages all compatible with IR reflow soldering process and come in 8-mm tape on a 7-in. diameter reel. They are compatible with automatic placement equipment.

To facilitate pick-and-place operation, these chipLEDs are shipped in tape and reel with 4000 units per reel for the HSMW-C120, C130, C191, and C197 packages, and 3000 units per reel for the HSMW-C265 package.

Features

- White color
- Small size
- Industry-standard footprint
- Compatible with reflow soldering
- Compatible with automatic placement equipment
- Operating temperature range -40°C to $+85^{\circ}\text{C}$
- Come in 8-mm tape on 7-in. diameter reels

Applications

- LCD backlighting
- Keypad backlighting
- Pushbutton backlighting
- Symbol backlighting

CAUTION! HSMW-Cxxx LEDs are Class 1A ESD sensitive per JESD22-A114C.01. Observe appropriate precautions during handling and processing. Refer to Broadcom Application Note AN-1142 for additional details.

Package Dimensions

HSMW-C120

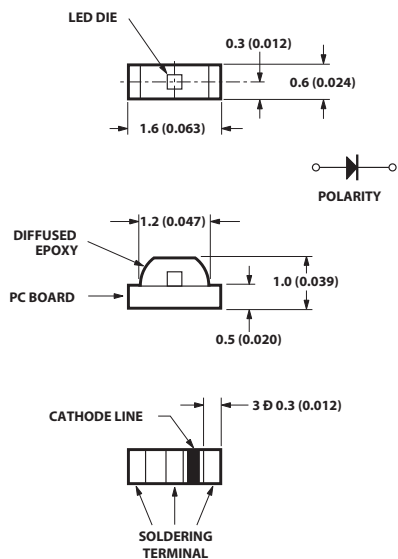

HSMW-C130

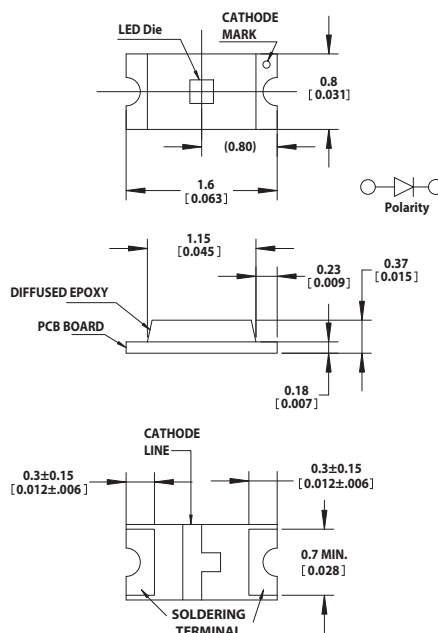

HSMW-C191

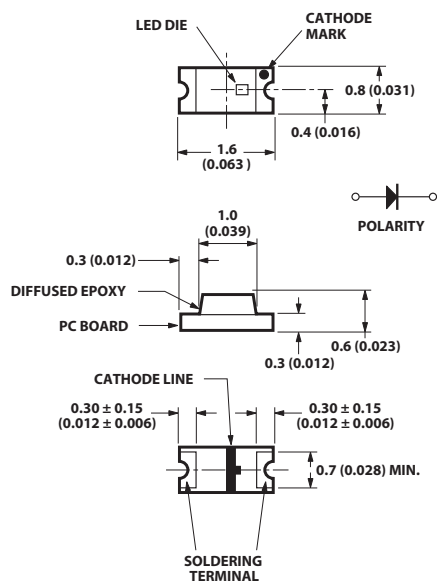

HSMW-C197

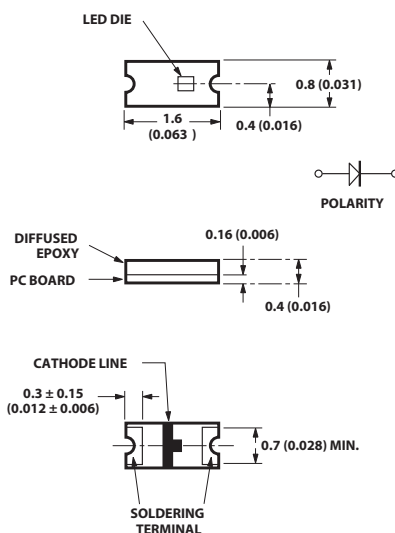

NOTE:

1. All dimensions are in millimeters (inches).
2. Tolerance is ± 0.1 mm (± 0.004 in.) unless otherwise noted.

HSMW-C150

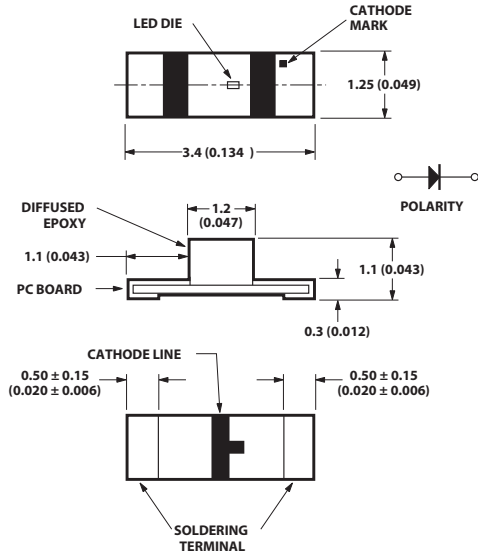

NOTE:

1. All dimensions are in millimeters (inches).
2. Tolerance is ± 0.1 mm unless otherwise noted.

Device Selection Guide

Package Dimensions (mm)	White	Package Description
1.6 (L) × 0.6 (W) × 1.0 (H) ^a	HSMW-C120	Untinted, Diffused
1.6 (L) × 0.8 (W) × 0.37 (H)	HSMW-C130	Untinted, Diffused
1.6 (L) × 0.8 (W) × 0.6 (H)	HSMW-C191	Untinted, Diffused
1.6 (L) × 0.8 (W) × 0.4 (H)	HSMW-C197	Untinted, Diffused
3.4 (L) × 1.25 (W) × 1.1 (H) ^b	HSMW-C265	Untinted, Diffused

- a. Right-angle package.
- b. Reverse-mount package.

Absolute Maximum Ratings at $T_A = 25^\circ\text{C}$

Parameter	HSMW-Cxxx	Units
DC Forward Current ^a	20	mA
Power Dissipation	78	mW
Reverse Voltage ($I_R = 100 \mu\text{A}$)	5	V
LED Junction Temperature	95	$^\circ\text{C}$
Operating Temperature Range	-40 to +85	$^\circ\text{C}$
Storage Temperature Range	-40 to +85	$^\circ\text{C}$
Soldering Temperature	See reflow soldering profile (Figure 11 and Figure 12)	

a. Derate linearly as shown in Figure 4.

Electrical Characteristics at $T_A = 25^\circ\text{C}$

Part Number	Forward Voltage V_F (V) at $I_F = 20 \text{ mA}^a$		Reverse Breakdown V_R (V) at $I_R = 100 \mu\text{A}$	Capacitance C (pF), $V_F = 0, f = 1 \text{ MHz}$	Thermal Resistance $R_{\theta\text{J-PIN}}$ ($^\circ\text{C/W}$)
	Typ.	Max.	Min.	Typ.	Typ.
HSMW-Cxxx	3.6	3.9	5	55	450

a. V_F tolerance: $\pm 0.1\text{V}$.

Optical Characteristics at $T_A = 25^\circ\text{C}$

Part Number	Luminous Intensity I_v (mcd) at $20 \text{ mA}^a, b$		Chromaticity Coordinates ^c Typ.		Luminous Viewing Angle $20_{1/2}$ Degrees ^d	Efficacy η_v (lm/w)
	Min.	Typ.	x	y	Typ.	Typ.
HSMW-C120	45	160	0.29	0.27	155	240
HSMW-C130	45	150	0.29	0.27	145	240
HSMW-C191	71.5	200	0.29	0.27	140	240
HSMW-C197	45	160	0.29	0.27	130	240
HSMW-C265	71.5	180	0.29	0.27	150	240

a. The luminous intensity, I_v , is measured at the peak of the spatial radiation pattern which may not be aligned with the mechanical axis of the lamp package.

b. Luminous intensity (I_v) tolerance: $\pm 15\%$.

c. The dominant wavelength, λ_d , is derived from the CIE Chromaticity Diagram and represents the perceived color of the device.

d. $\Sigma_{1/2}$ is the off-axis angle where the luminous intensity is $1/2$ the peak intensity.

Light Intensity (Iv) Bin Limits (see Note)

Bin ID	Intensity (mcd)	
	Min.	Max.
A	0.11	0.18
B	0.18	0.29
C	0.29	0.45
D	0.45	0.72
E	0.72	1.10
F	1.10	1.80
G	1.80	2.80
H	2.80	4.50
J	4.50	7.20
K	7.20	11.20
L	11.20	18.00
M	18.00	28.50
N	28.50	45.00
P	45.00	71.50
Q	71.50	112.50
R	112.50	180.00
S	180.00	285.00
T	285.00	450.00
U	450.00	715.00
V	715.00	1125.00
W	1125.00	1800.00
X	1800.00	2850.00
Y	2850.00	4500.00

Tolerance: ± 15%.

NOTE: Bin categories are established for classification of products. Products may not be available in all categories. Contact your Broadcom representative for information on currently available bins.

Bin	Limits (Chromaticity Coordinate)		
	x	y	
A1	0.270	0.246	
	0.270	0.278	
	0.250	0.250	
	0.250	0.218	
A2	0.270	0.246	
	0.270	0.213	
	0.250	0.185	
	0.250	0.218	
	B1	0.270	0.246
		0.270	0.278
0.290		0.306	
0.290		0.274	
B2	0.270	0.246	
	0.270	0.213	
	0.290	0.241	
	0.290	0.274	
	C1	0.290	0.306
		0.310	0.336
0.310		0.303	
0.290		0.274	
C2	0.290	0.241	
	0.310	0.271	
	0.310	0.303	
	0.290	0.274	
D1	0.310	0.303	
	0.310	0.336	
	0.330	0.365	
	0.330	0.333	
D2	0.310	0.303	
	0.310	0.271	
	0.330	0.300	
	0.330	0.333	

Figure 1: Color Bin Limits (CIE 1931 Chromaticity Diagram)
[Tolerance: ± 0.02]

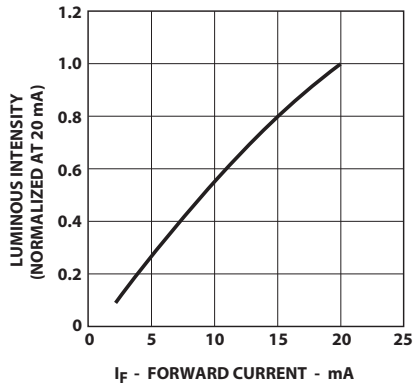

Figure 2: Forward Current vs. Forward Voltage

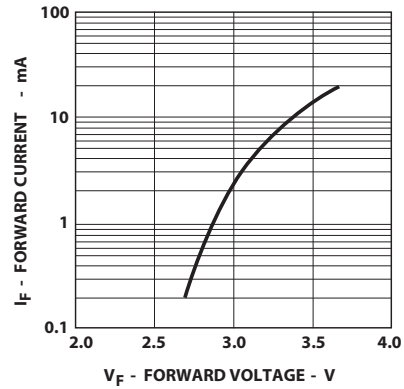

Figure 3: Luminous Intensity vs. Forward Current

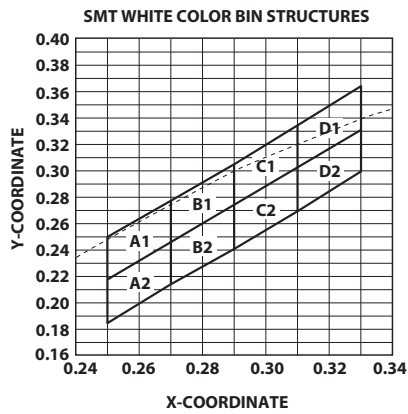

Figure 4: Maximum Forward Current vs. Ambient Temperature

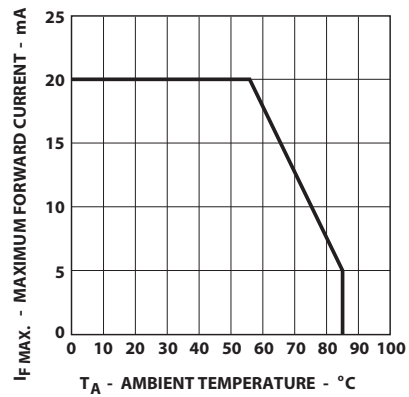

Figure 5: Relative Intensity vs. Angle for HSMW-C120

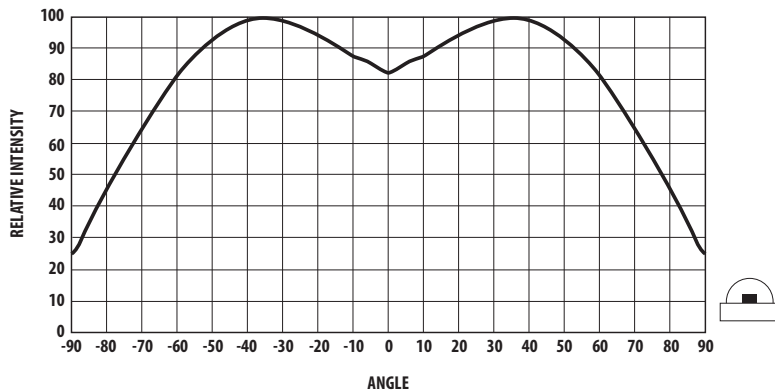

Figure 6: Relative Intensity vs. Angle for HSMW-C120

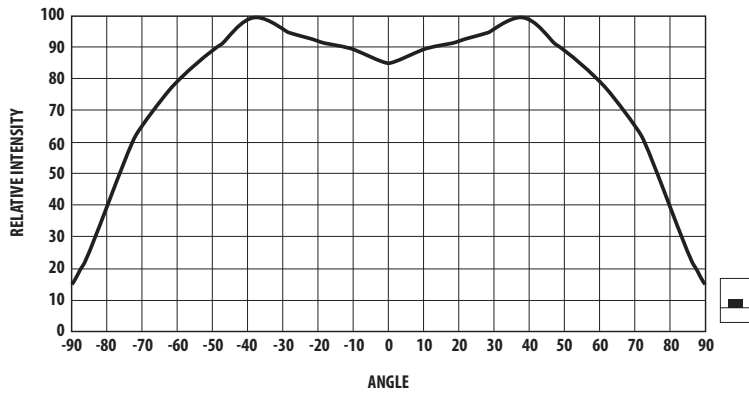

Figure 7: Relative Intensity vs. Angle for HSMW-C130

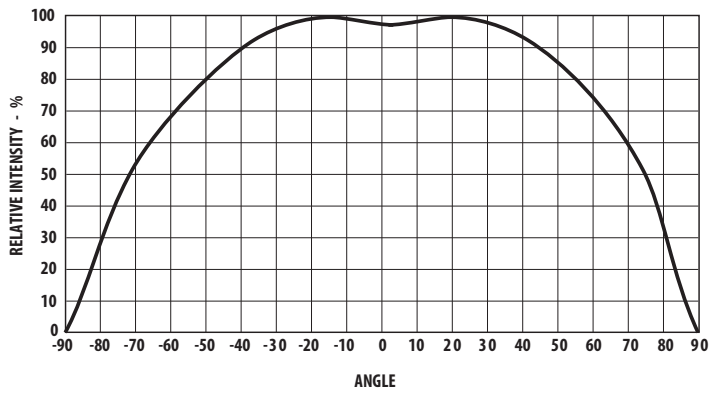

Figure 8: Relative Intensity vs. Angle for HSMW-C191

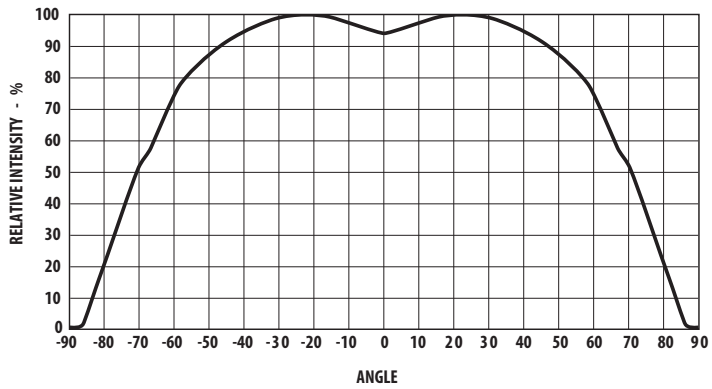

Figure 9: Relative Intensity vs. Angle for HSMW-C197

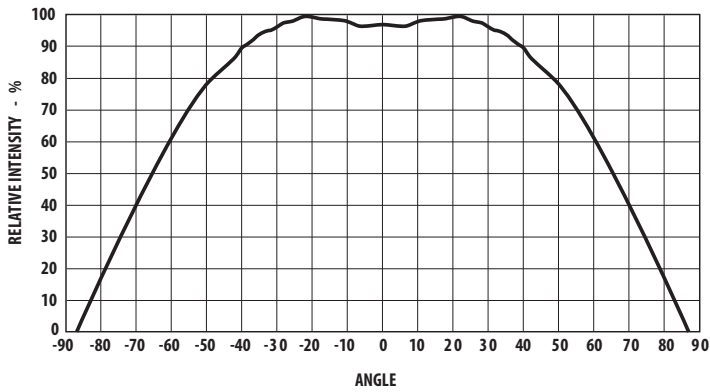

Figure 10: Relative Intensity vs. Angle for HSMW-C265

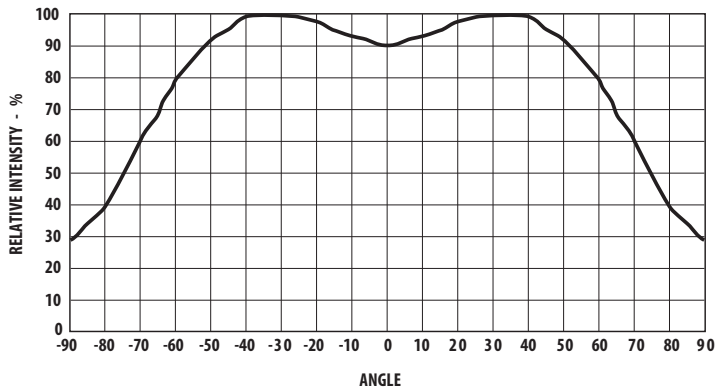

Figure 11: Recommended Reflow Soldering Profile

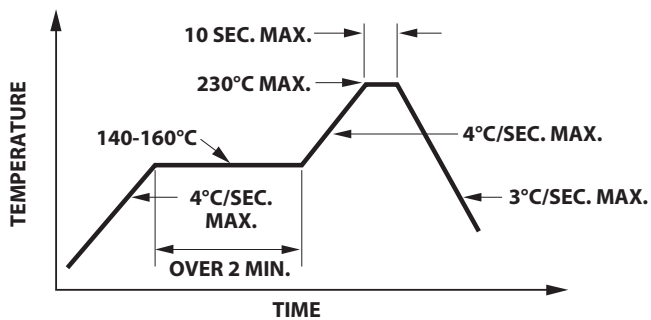

Figure 12: Recommended Pb-free Reflow Soldering Profile

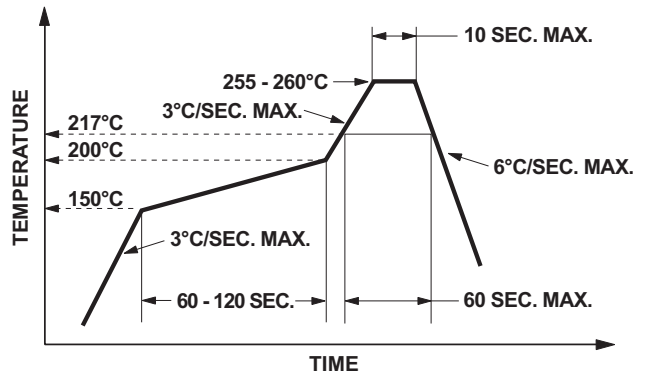

Figure 13: Recommended Soldering Pad Pattern for HSMW-C120

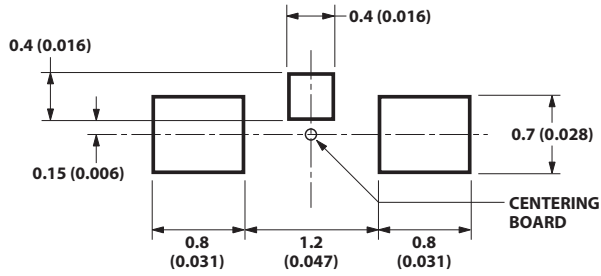

Figure 14: Recommended Soldering Pad Pattern for HSMW-C130, HSMW-C191, and HSMW-C197

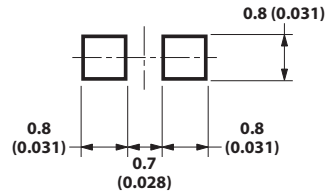
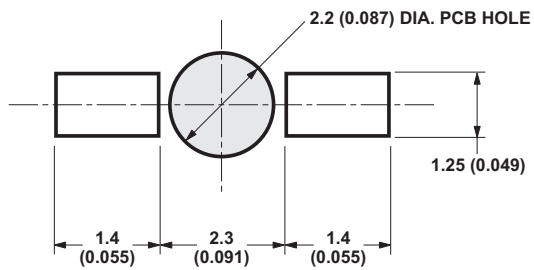

Figure 15: Recommended Soldering Pad Pattern for HSMW-C265



NOTE: Dimensions are in millimeters (inches).

Figure 16: Reeling Orientation

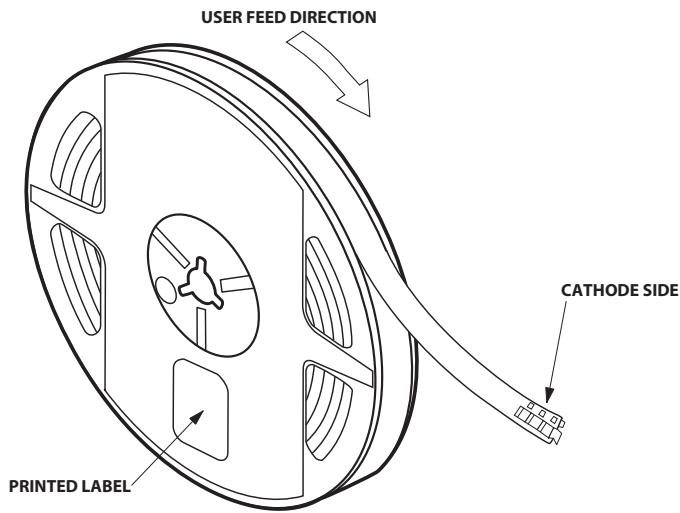
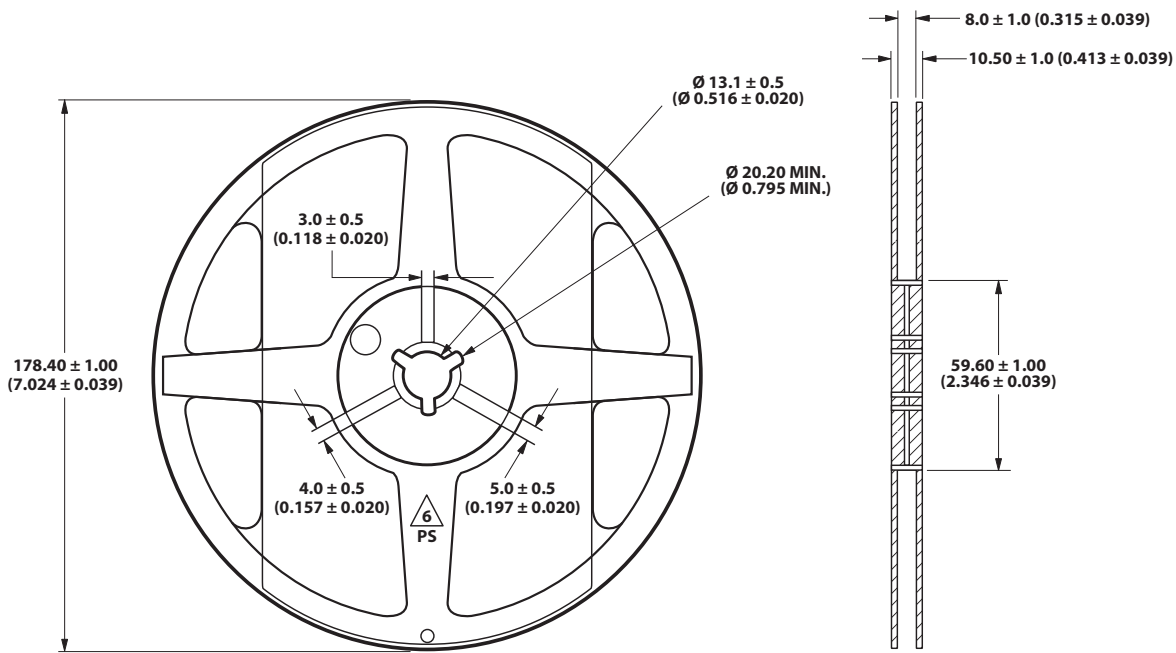

Figure 17: Reel Dimensions



NOTE: Dimensions are in millimeters (inches).

Figure 18: Tape Dimensions

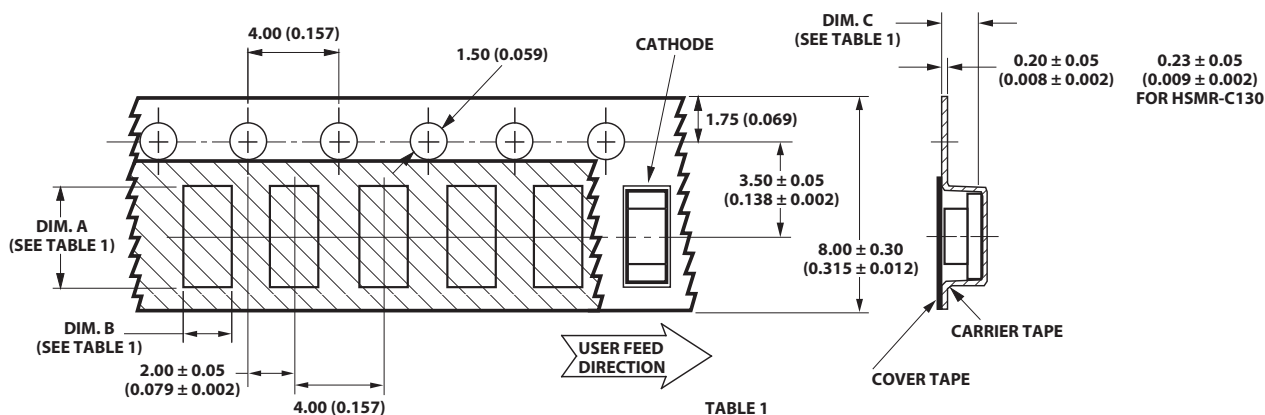

TABLE 1
DIMENSIONS IN MILLIMETERS (INCHES)

PART NUMBER	DIM. A ± 0.10 (0.004)	DIM. B ± 0.10 (0.004)	DIM. C ± 0.10 (0.004)
HSMx-C120 SERIES	1.90 (0.075)	1.15 (0.045)	0.80 (0.031)
HSMx-C130 SERIES	1.75 (0.069)	0.88 (0.035)	0.50 (0.020)
HSMx-C191 SERIES	1.85 (0.073)	0.88 (0.035)	0.88 (0.035)
HSMx-C197 SERIES	1.75 (0.069)	0.95 (0.037)	0.60 (0.024)

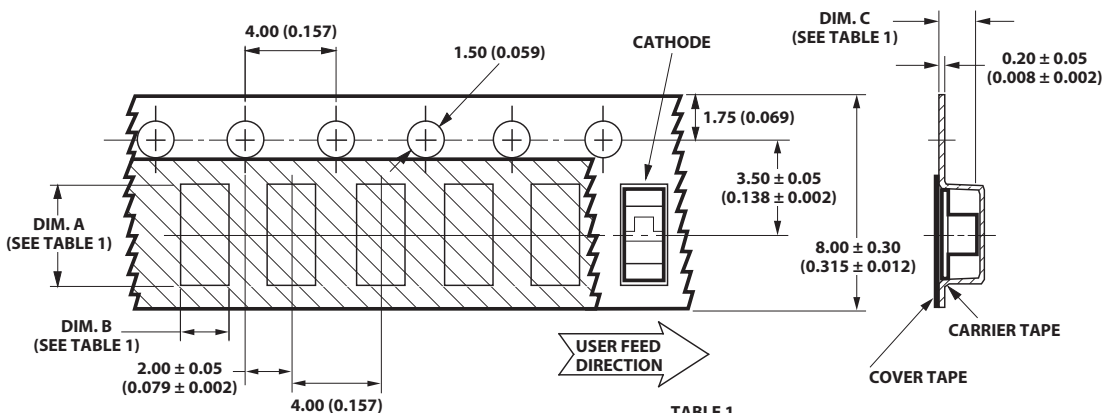
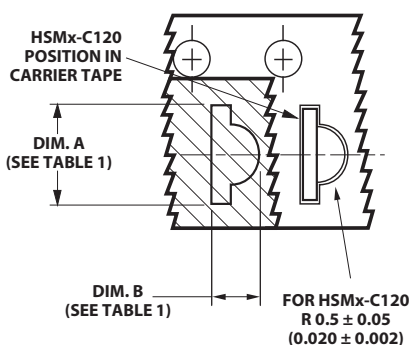
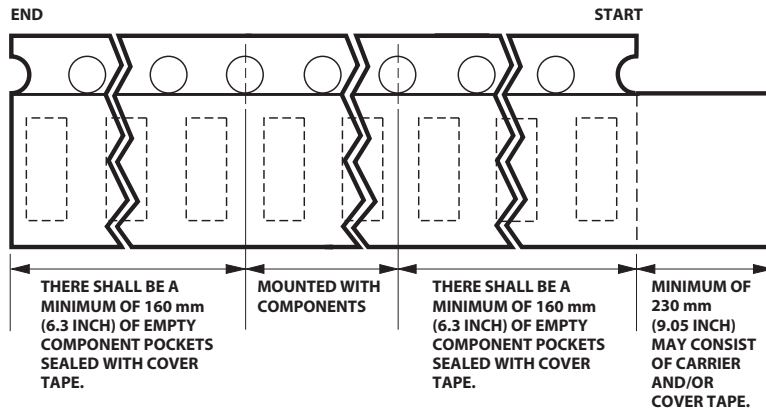

TABLE 1
DIMENSIONS IN MILLIMETERS (INCHES)

PART NUMBER	DIM. A ± 0.10 (0.004)	DIM. B ± 0.10 (0.004)	DIM. C ± 0.10 (0.004)
HSMx-C265 SERIES	3.70 (0.146)	1.45 (0.057)	1.30 (0.051)

NOTE: Dimensions are in millimeters (inches).

Figure 19: Tape Leader and Trailer Dimensions



Convective IR Reflow Soldering

For more information on IR reflow soldering, refer to Application Note 1060, *Surface Mounting SMT LED Indicator Components*.

Storage Condition

5°C to 30°C at 60% RH maximum.

Baking is required under the following conditions:

1. The humidity indicator card is > 10% when read at 23°C ± 5°C.
2. The device is exposed to factory conditions < 30°C/60% RH for more than 672 hours.

Baking recommended conditions: 60°C ± 5°C for 20 hours.

Broadcom, the pulse logo, Connecting everything, Avago Technologies, Avago, and the A logo are among the trademarks of Broadcom and/or its affiliates in the United States, certain other countries, and/or the EU.

Copyright © 2010–2020 Broadcom. All Rights Reserved.

The term “Broadcom” refers to Broadcom Inc. and/or its subsidiaries. For more information, please visit www.broadcom.com.

Broadcom reserves the right to make changes without further notice to any products or data herein to improve reliability, function, or design. Information furnished by Broadcom is believed to be accurate and reliable. However, Broadcom does not assume any liability arising out of the application or use of this information, nor the application or use of any product or circuit described herein, neither does it convey any license under its patent rights nor the rights of others.

Looking for pricing, stock, or lifecycle information?

Click below to explore more details on WIN SOURCE:

 [View HSMW-C130 on WIN SOURCE](#)

 [Broadcom Limited](#) Information

Optimize Your Supply Chain with WIN SOURCE Solutions

-  Global Sourcing Solution
-  Obsolete Management
-  Cost Control Management
-  Shortage Management
-  Alternative Solution
-  Excess Inventory Management