



**THE DATASHEET OF
BUF08630RGWR**





Programmable Gamma-Voltage Generator and High Slew Rate V_{COM} with Integrated Two-Bank Memory plus 1/2 AVDD Topology

 Check for Samples: [BUF08630](#)

FEATURES

- 10-Bit Resolution
- 8-Channel P-Gamma
- 1-Channel P- V_{COM}
- High Slew Rate V_{COM} : 45 V/ μ s
- 16x Rewritable Nonvolatile Memory
- Two Independent Pin-Selectable Memory Banks
- Rail-to-Rail Output:
 - 300 mV Min Swing-to-Rail (10 mA)
 - > 300 mA Max I_{OUT}
- Low Supply Current
- Supply Voltage: 9 V to 20 V
- Digital Supply: 2 V to 5.5 V
- Two-Wire Interface:
 - Supports 400 kHz and 3.4 MHz
- 1/2 AVDD Capability

APPLICATIONS

- TFT-LCD Reference Drivers

DESCRIPTION

The BUF08630 offers eight programmable gamma channels and one programmable V_{COM} channel.

The final gamma and V_{COM} values can be stored in the on-chip, nonvolatile memory. To allow for programming errors or liquid crystal display (LCD) panel rework, the BUF08630 supports up to 16 write operations to the on-chip memory.

The BUF08630 has two separate memory banks, allowing simultaneous storage of two different gamma curves to facilitate switching between gamma curves.

All gamma and V_{COM} channels offer a rail-to-rail output that typically swings to within 150 mV of either supply rail with a 10-mA load. All channels are programmed using a two-wire interface that supports standard operations up to 400 kHz, and high-speed data transfers up to 3.4 MHz.

The BUF08630 is manufactured using Texas Instruments' proprietary, state-of-the-art, high-voltage CMOS process. This process offers very dense logic and high supply voltage operation of up to 20V. The BUF08630 is available in a 20-pin QFN package, and is specified from -40°C to $+95^{\circ}\text{C}$.

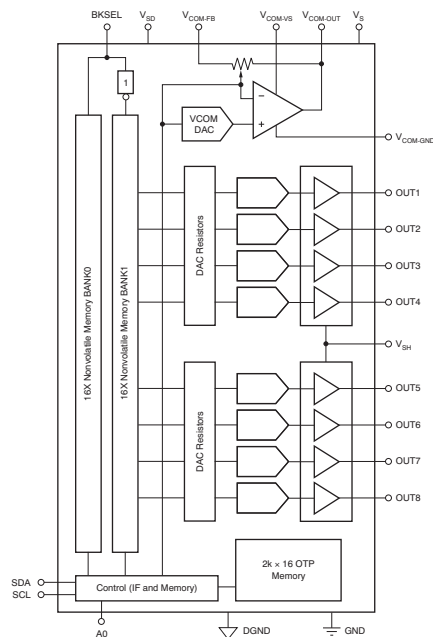

RELATED PRODUCTS

FEATURES	PRODUCT
22-channel gamma correction buffer	BUF22821
16-channel gamma correction buffer	BUF16821
12-channel gamma correction buffer	BUF12800
18-/20-channel programmable buffer, 10-Bit, V_{COM}	BUF20800
18-/20-Channel programmable buffer with memory	BUF20820
Programmable V_{COM} driver	BUF01900
22-V supply, traditional gamma buffers	BUF11705
High-resolution, fully-programmable LCD bias IC for TV	TPS65168



Please be aware that an important notice concerning availability, standard warranty, and use in critical applications of Texas Instruments semiconductor products and disclaimers thereto appears at the end of this data sheet.

All trademarks are the property of their respective owners.



This integrated circuit can be damaged by ESD. Texas Instruments recommends that all integrated circuits be handled with appropriate precautions. Failure to observe proper handling and installation procedures can cause damage.

ESD damage can range from subtle performance degradation to complete device failure. Precision integrated circuits may be more susceptible to damage because very small parametric changes could cause the device not to meet its published specifications.

PACKAGE/ORDERING INFORMATION⁽¹⁾

PRODUCT	PACKAGE	PACKAGE DESIGNATOR	PACKAGE MARKING
BUF08630	VQFN-20	RGW	BUF08630

(1) For the most current package and ordering information see the Package Option Addendum at the end of this document, or see the device product folder at www.ti.com.

ABSOLUTE MAXIMUM RATINGS⁽¹⁾

Over operating free-air temperature range (unless otherwise noted).

		BUF08630	UNIT
Supply voltage	V _S	+22	V
	V _{SH}	GND + 4.0 < V _{SH} < V _S - 4.0	V
	V _{SD}	+6	V
Digital input pins, SCL, SDA, AO, BKSEL: voltage		-0.5 to +6	V
Digital input pins, SCL, SDA, AO, BKSEL: current		±10	mA
Output pins, OUT1 through OUT4 ⁽²⁾		(V-) - 0.5 to (V _{SH}) + 0.5	V
Output pins, OUT5 through OUT8 ⁽²⁾		(V _{SH}) - 0.5 to (V+) + 0.5	V
V _{COM} ⁽²⁾		(V-) - 0.5 to (V+) + 0.5	V
Output short-circuit ⁽³⁾		Continuous	
Ambient operating temperature		-40 to +95	°C
Ambient storage temperature		-65 to +150	°C
Junction temperature, T _J		+125	°C
ESD ratings	Human body model (HBM)	4	kV
	Charged device model (CDM)	1	kV
	Machine model (MM)	200	V

- (1) Stresses above these ratings may cause permanent damage. Exposure to absolute maximum conditions for extended periods may degrade device reliability. These are stress ratings only, and functional operation of the device at these or any other conditions beyond those specified is not supported.
- (2) See the [Output Protection](#) section.
- (3) Short-circuit to ground, one amplifier per package. Exposed thermal die is soldered to the printed circuit board (PCB) using thermal vias. Refer to Texas Instruments' application report [SLAU271, QFN/SON PCB Attachment](#).

THERMAL INFORMATION

THERMAL METRIC ⁽¹⁾		BUF08630	UNITS
		RGW	
		20 PINS	
θ _{JA}	Junction-to-ambient thermal resistance	42.4	°C/W
θ _{JC(top)}	Junction-to-case(top) thermal resistance	34.4	
θ _{JB}	Junction-to-board thermal resistance	10.4	
ψ _{JT}	Junction-to-top characterization parameter	8.2	
ψ _{JB}	Junction-to-board characterization parameter	42.4	
θ _{JC(bottom)}	Junction-to-case(bottom) thermal resistance	2.1	

(1) For more information about traditional and new thermal metrics, see the *IC Package Thermal Metrics* application report, [SPRA953](#).

ELECTRICAL CHARACTERISTICS

Boldface limits apply over the specified temperature range, $T_A = -40^{\circ}\text{C}$ to $+95^{\circ}\text{C}$.

At $T_A = +25^{\circ}\text{C}$, $V_S = +18\text{ V}$, $V_{SH} = 9.0\text{ V}$, $V_{SD} = +2\text{ V}$, and $C_L = 200\text{ pF}$, unless otherwise noted.

PARAMETER	CONDITIONS	BUF08630			UNIT
		MIN	TYP	MAX	
ANALOG GAMMA BUFFER CHANNELS					
Reset value	Code = 512		9		V
OUT1, 4 output swing: high	Code = 1023, sourcing 10 mA	17.7	17.85		V
OUT1, 4 output swing: low	Code = 512, sinking 10 mA		$V_{SH} + 0.07$	$V_{SH} + 0.3$	V
OUT2, 3 output swing: high	Code = 1023, sourcing 10 mA	17.5	17.85		V
OUT2, 3 output swing: low	Code = 512, sinking 10 mA		$V_{SH} + 0.07$	$V_{SH} + 0.5$	V
OUT5, 8 output swing: high	Code = 511, sourcing 10 mA	$V_{SH} - 0.3$	$V_{SH} - 0.15$		V
OUT5, 8 output swing: low	Code = 0, sinking 10 mA		0.05	0.3	V
OUT6, 7 output swing: high	Code = 511, sourcing 10 mA	$V_{SH} - 0.5$	$V_{SH} - 0.15$		V
OUT6, 7 output swing: low	Code = 0, sinking 10 mA		0.05	0.5	V
V_{COM} output swing: high ⁽¹⁾	Code = 960, sourcing 400 mA	13	15.3		V
V_{COM} output swing: low ⁽¹⁾	Code = 0, sinking 400 mA		3.8	5	V
vs Temperature	Code = 0, sinking 400 mA			6	V
V_{COM} slew rate ⁽²⁾	$R_{LOAD} = 60\ \Omega$, $C_{LOAD} = 100\text{ pF}$		45		V/ μs
Continuous output current	Note ⁽³⁾		30		mA
Output accuracy, V_{COM} ⁽⁴⁾	Code = 512		± 20	± 50	mV
vs Temperature	Code = 512		± 25		$\mu\text{V}/^{\circ}\text{C}$
Output accuracy, OUT1 to OUT4	Code = 768, $V_{SH} = 9\text{ V}$, $V_S = 18\text{ V}$		± 20	± 50	mV
vs Temperature	Code = 768		± 25		$\mu\text{V}/^{\circ}\text{C}$
Output accuracy, OUT5 to OUT8	Code = 256, $V_{SH} = 9\text{ V}$, $V_S = 18\text{ V}$		± 20	± 50	mV
vs Temperature	Code = 256		± 25		$\mu\text{V}/^{\circ}\text{C}$
Integral nonlinearity ⁽⁴⁾	INL		0.3		LSB
Differential nonlinearity ⁽⁴⁾	DNL		0.3		LSB
Load regulation	REG	OUT1 to OUT4 code = 768, $I_{OUT} = +5\text{-mA}$ to -5-mA step	0.5	1.5	mV/mA
		OUT5 to OUT8 code = 256, $I_{OUT} = +5\text{-mA}$ to -5-mA step	0.5	1.5	mV/mA
OTP MEMORY					
Number of OTP write cycles				16	Cycles
Memory retention			100		Years
ANALOG POWER SUPPLY					
Operating range			9	20	V
Total analog supply current	I_S	OUT1 to OUT4 set code = 768, OUT5 to OUT8 set code = 256, no load	6.9	11	mA
Over temperature				11	mA
DIGITAL					
Logic 1 input voltage	V_{IH}		$0.7 \times V_{SD}$		V
Logic 0 input voltage	V_{IL}			$0.3 \times V_{SD}$	V
Logic 0 output voltage	V_{OL}	$I_{SINK} = 3\text{-mA}$	0.15	0.4	V
Input leakage			± 0.01	± 10	μA
Clock frequency	f_{CLK}	Standard/Fast mode		400	kHz
		High-Speed mode		3.4	MHz
DIGITAL POWER SUPPLY					
Specified range	DV_{DD}		2.0	5.5	V
Digital supply current ⁽³⁾	DI_{DD}	Outputs at reset values, no load, two-wire bus inactive	115	180	μA
Over temperature			115	180	μA

(1) The BUF08630 V_{COM} DAC limits can be programmed. These default limits apply if the device is not programmed. See the [Programmable Vcom Limits](#) section.

(2) See [Figure 19, Large-Signal Step Response, \$V_{COM}\$](#) .

(3) Observe maximum power dissipation.

(4) The V_{COM} output voltage is limited to codes 0 to 960 because of the common-mode input range of the V_{COM} amplifier. This limitation is for V_{COM} only; it does not affect DAC OUT1 to 8.

ELECTRICAL CHARACTERISTICS (continued)

Boldface limits apply over the specified temperature range, $T_A = -40^{\circ}\text{C}$ to $+95^{\circ}\text{C}$.

At $T_A = +25^{\circ}\text{C}$, $V_S = +18\text{ V}$, $V_{SH} = 9.0\text{ V}$, $V_{SD} = +2\text{ V}$, and $C_L = 200\text{ pF}$, unless otherwise noted.

PARAMETER	CONDITIONS	BUF08630			UNIT
		MIN	TYP	MAX	
TEMPERATURE RANGE					
Specified range		-40		+95	$^{\circ}\text{C}$
Storage range		-65		+150	$^{\circ}\text{C}$

PIN CONFIGURATION

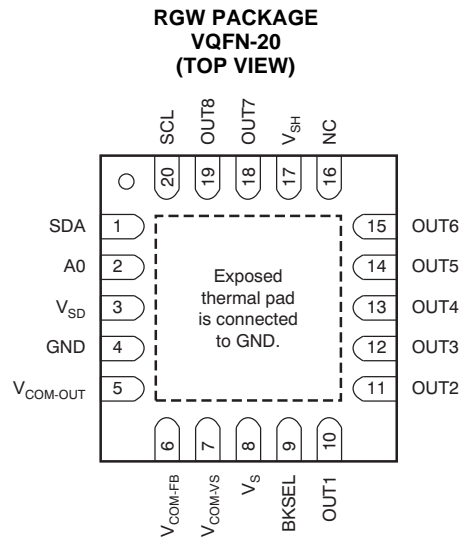

PIN DESCRIPTIONS

PIN NAME	PIN NO.	DESCRIPTION
A0	2	A0 address pin for two-wire address; connect to either logic 1 or logic 0. See Table 1 .
BKSEL	9	Selects memory bank 0 or 1; connect to either logic 1 to select bank 1 or logic 0 to select bank 0.
GND	4	Ground
NC	16	No Connect
OUT1	10	DAC output 1
OUT2	11	DAC output 2
OUT3	12	DAC output 3
OUT4	13	DAC output 4
OUT5	14	DAC output 5
OUT6	15	DAC output 6
OUT7	18	DAC output 7
OUT8	19	DAC output 8
SCL	20	Serial clock input; connect to pull-up resistor.
SDA	1	Serial data I/O; open-drain, connect to pull-up resistor.
$V_{COM-AVDD}$	7	V_{COM} supply
V_{COM-FB}	6	V_{COM} feedback
$V_{COM-OUT}$	5	V_{COM} output
V_S	8	V_S connected to analog supply.
V_{SD}	3	Digital supply; connect to logic supply.
V_{SH}	17	V_{SH} connected to 1/2 analog supply.

TYPICAL CHARACTERISTICS

At $T_A = +25^\circ\text{C}$, $V_S = +18\text{ V}$, $V_{SH} = +9\text{ V}$, and $V_{SD} = +2\text{ V}$, unless otherwise noted.

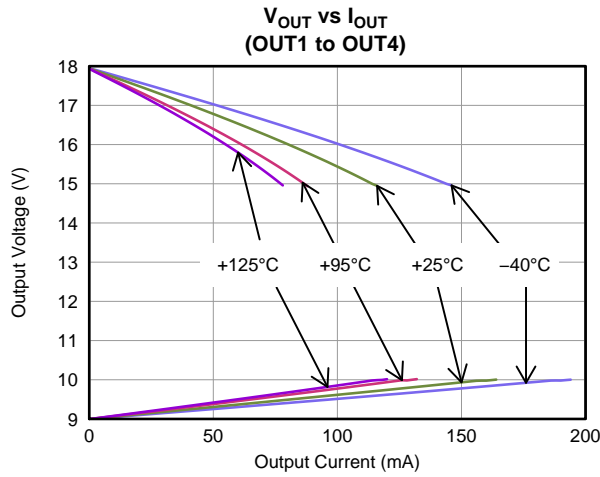

Figure 1.

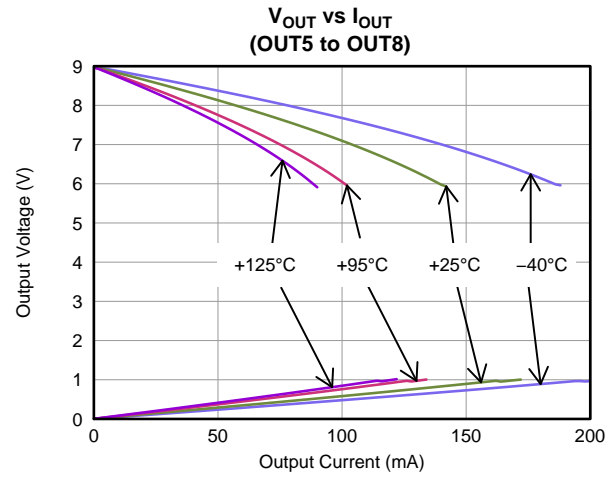

Figure 2.

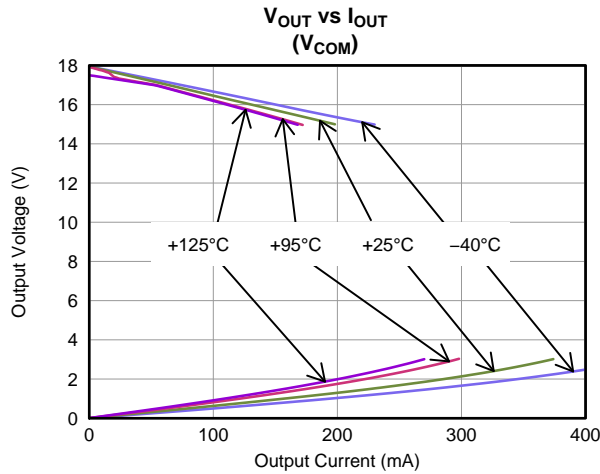

Figure 3.

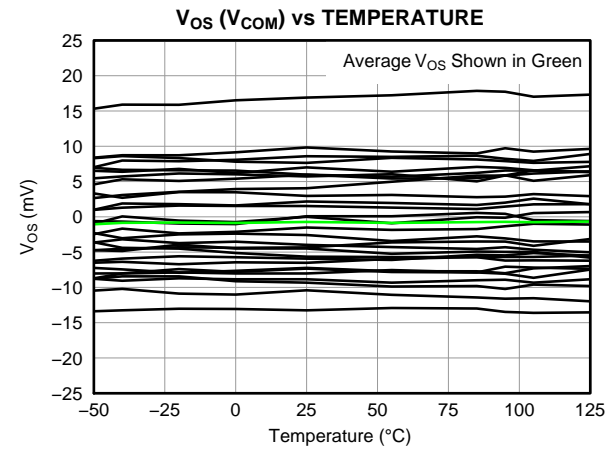

Figure 4.

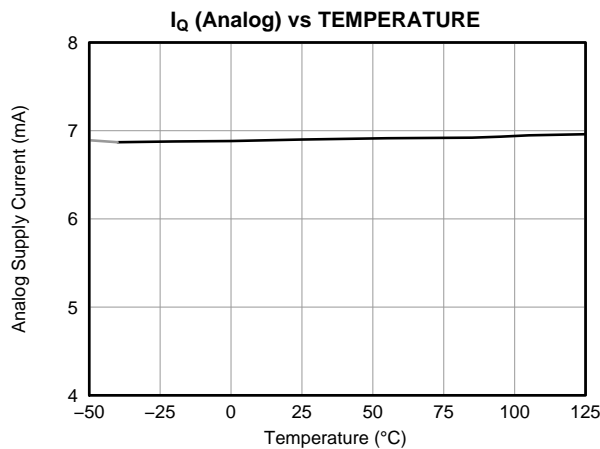

Figure 5.

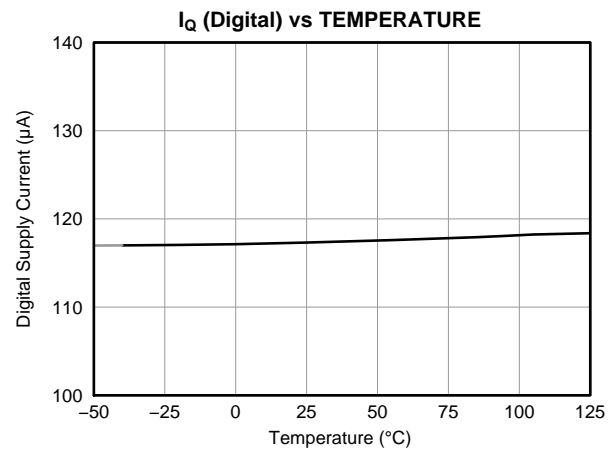

Figure 6.

TYPICAL CHARACTERISTICS (continued)

At $T_A = +25^\circ\text{C}$, $V_S = +18\text{ V}$, $V_{SH} = +9\text{ V}$, and $V_{SD} = +2\text{ V}$, unless otherwise noted.

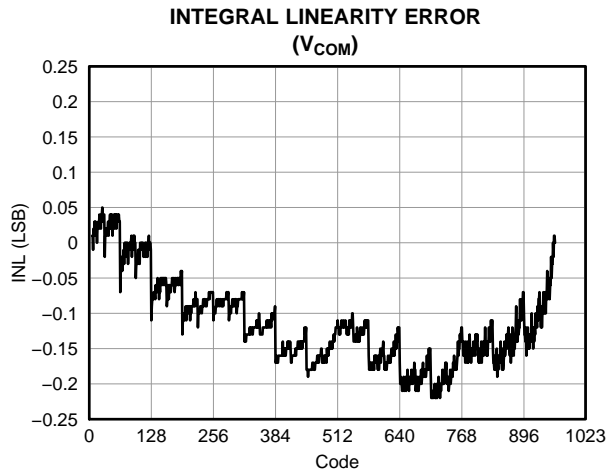

Figure 7.

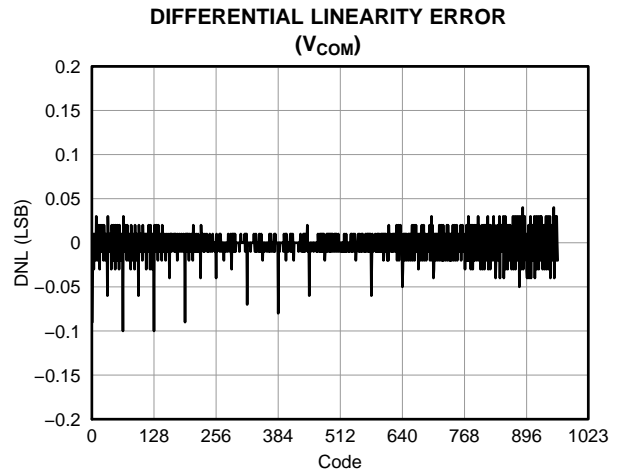

Figure 8.

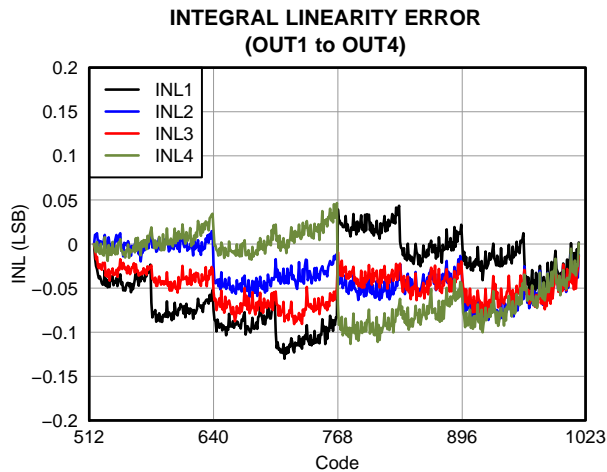

Figure 9.

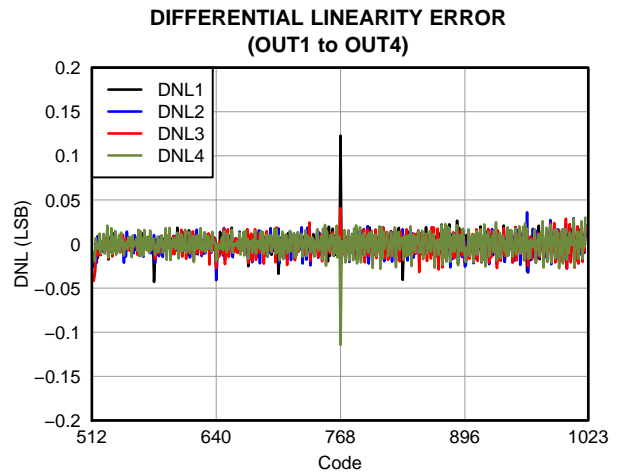

Figure 10.

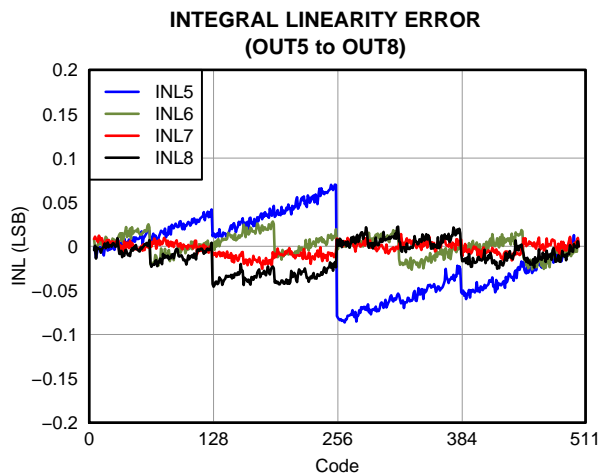

Figure 11.

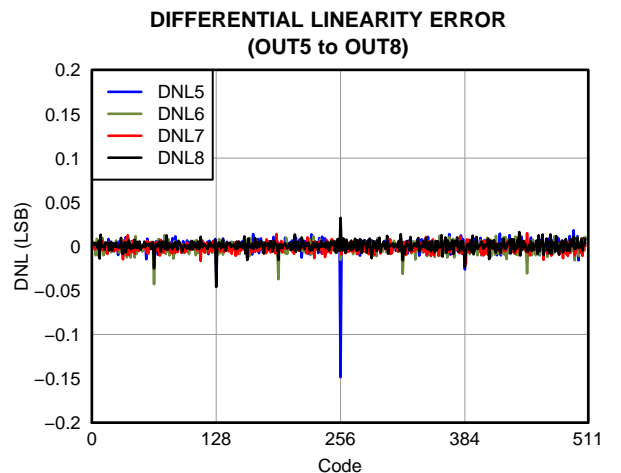

Figure 12.

TYPICAL CHARACTERISTICS (continued)

At $T_A = +25^\circ\text{C}$, $V_S = +18\text{ V}$, $V_{SH} = +9\text{ V}$, and $V_{SD} = +2\text{ V}$, unless otherwise noted.

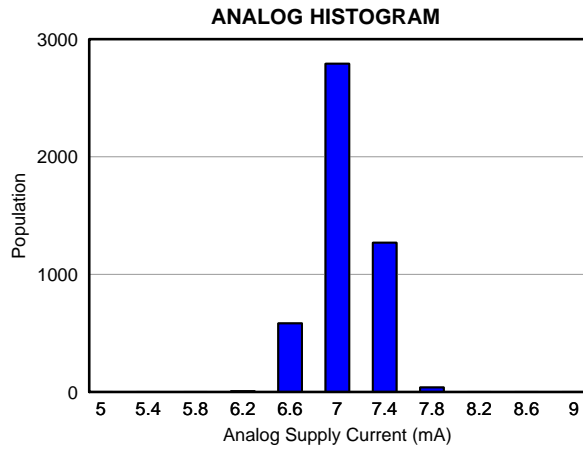

Figure 13.

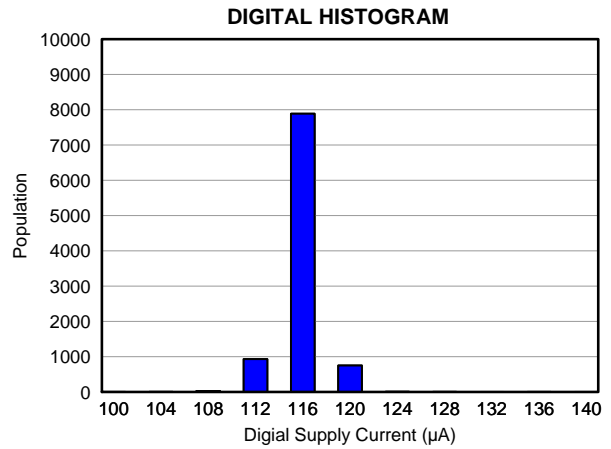

Figure 14.

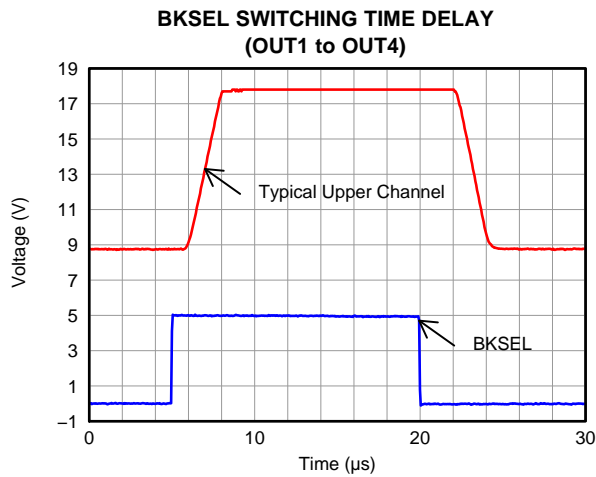

Figure 15.

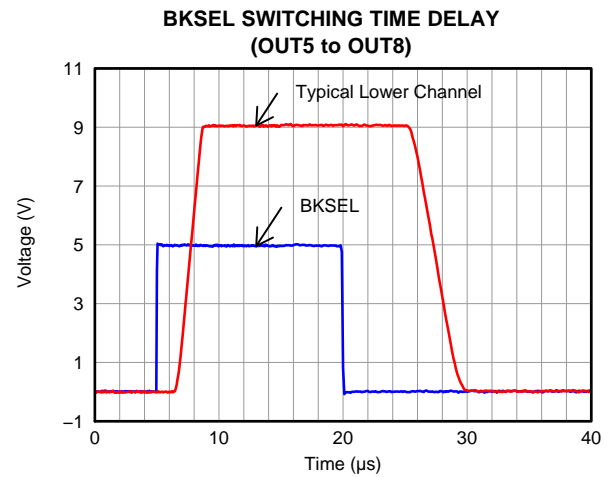

Figure 16.

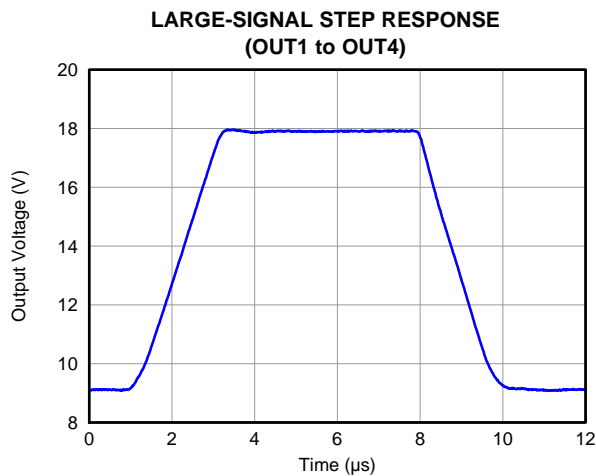

Figure 17.

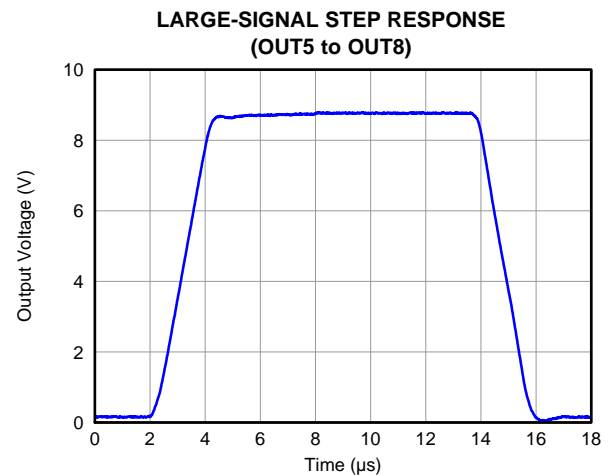

Figure 18.

TYPICAL CHARACTERISTICS (continued)

At $T_A = +25^\circ\text{C}$, $V_S = +18\text{ V}$, $V_{SH} = +9\text{ V}$, and $V_{SD} = +2\text{ V}$, unless otherwise noted.

LARGE-SIGNAL STEP RESPONSE

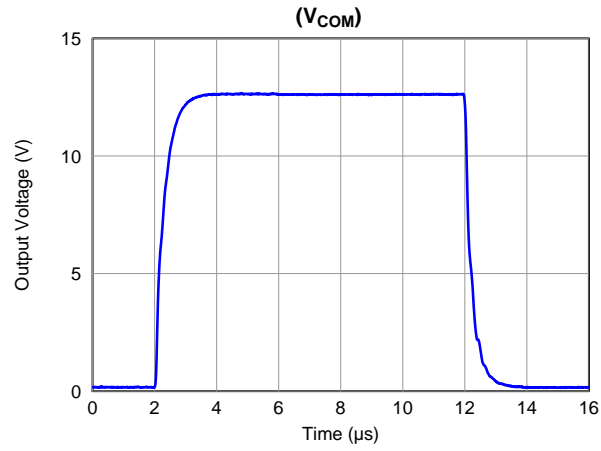

Figure 19.

APPLICATION INFORMATION

GENERAL DESCRIPTION

The BUF08630 programmable voltage reference allows fast and easy adjustment of eight programmable gamma reference outputs and a V_{COM} output, each with 10-bit resolution. The BUF08630 is programmed through a high-speed, two-wire interface. The final gamma and V_{COM} values can be stored in the onboard, nonvolatile memory. To allow for programming errors or liquid crystal display (LCD) panel rework, the BUF08630 supports up to 16 write operations to the onboard memory. The BUF08630 has two separate memory banks, allowing simultaneous storage of two different gamma curves to facilitate dynamic switching between gamma curves.

The BUF08630 can be powered using an analog supply voltage from 9 V to 20 V, and a digital supply from 2 V to 5.5 V. The digital supply must be applied before the analog supply to avoid excessive current and power consumption, or possibly even damage to the device if left connected only to the analog supply for extended periods of time. In addition, analog supply voltage V_S should be turned on before V_{SH} .

Power-Up Sequence

When applying power to the BUF08630, the digital supply must be powered up first. The analog supply for the V_{COM} amplifier (V_{COM-VS}), and the analog supply (V_S) should be brought up at least 1.2 ms later so that the programmed values in the nonvolatile memory can be written to the DAC registers. The analog supply voltage (V_{COM-VS}) must always precede V_S , or the two supply pins should be tied together so that they turn on and off simultaneously. The supply voltage V_{SH} must always follow V_S .

CAUTION

If V_{COM-VS} is brought up after V_S , damage will occur to the analog switches for V_{COM} .

It is recommended that the [TPS65168](#) be used together with the BUF08630 for best performance, as shown in [Figure 24](#). Note that the [TPS65168](#) provides the power sequence previously described and required by the BUF08630.

[Figure 20](#) shows the proper power-up sequence when two supplies are used (that is, V_S and V_{COM-VS} are connected together). [Figure 21](#) shows the proper power-up sequence when three supplies are used (that is, V_{SH} , V_S , and V_{COM-VS} are separate supplies).

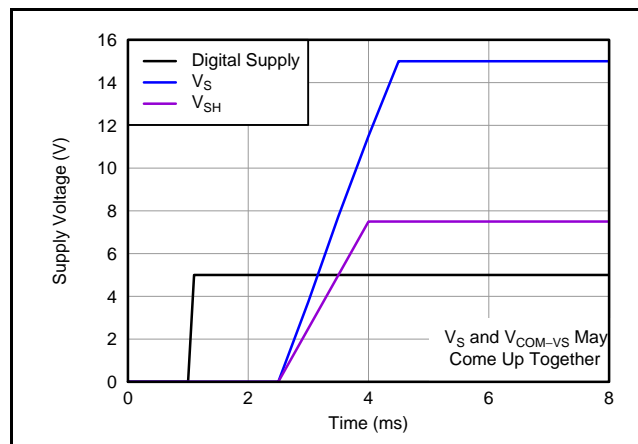

Figure 20. Startup Requirement with Two Supplies

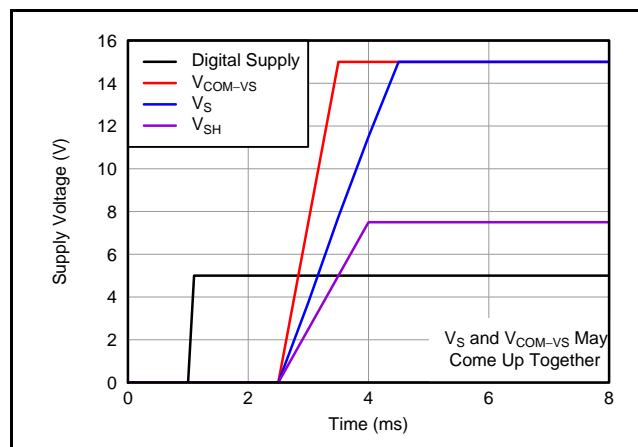

Figure 21. Startup Requirement with Three Supplies

Power-Down Sequence

When removing power from the BUF08630, the reverse sequence from that described in the *Power-Up Sequence* must be used. [Figure 22](#) shows the sequence that must be followed when V_{COM-VS} is connected to V_S . [Figure 23](#) shows the sequence that must be followed when V_{COM-VS} is not connected to V_S .

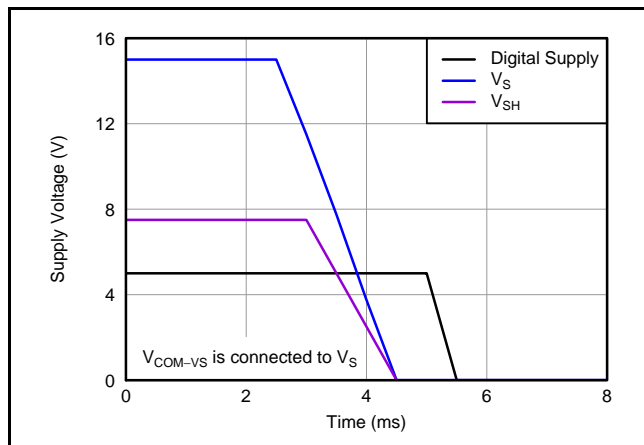

Figure 22. Shutdown Requirement with Two Supplies

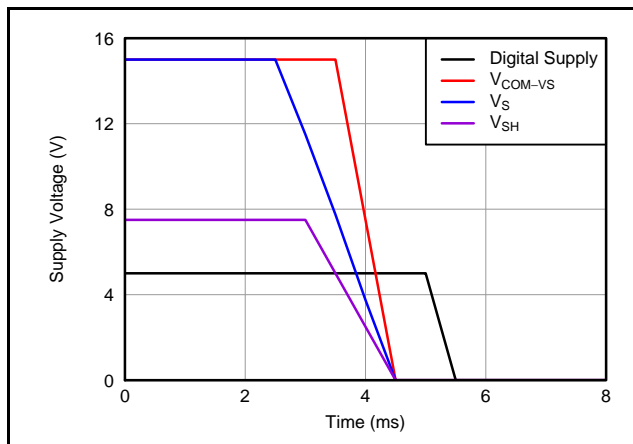

Figure 23. Shutdown Requirement with Three Supplies

A separate supply pin is provided for V_{COM-VS} so that separate supplies can be used for the gamma buffers and V_{COM} . The gamma buffers could be powered with a *clean* supply to prevent noise coupling into the gamma channels. The V_{COM} amplifier can then be supplied by a power source with more current capability, but with higher noise.

It is highly recommended that a Schottky diode be placed between V_S and V_{SH} , as shown in [Figure 37](#).

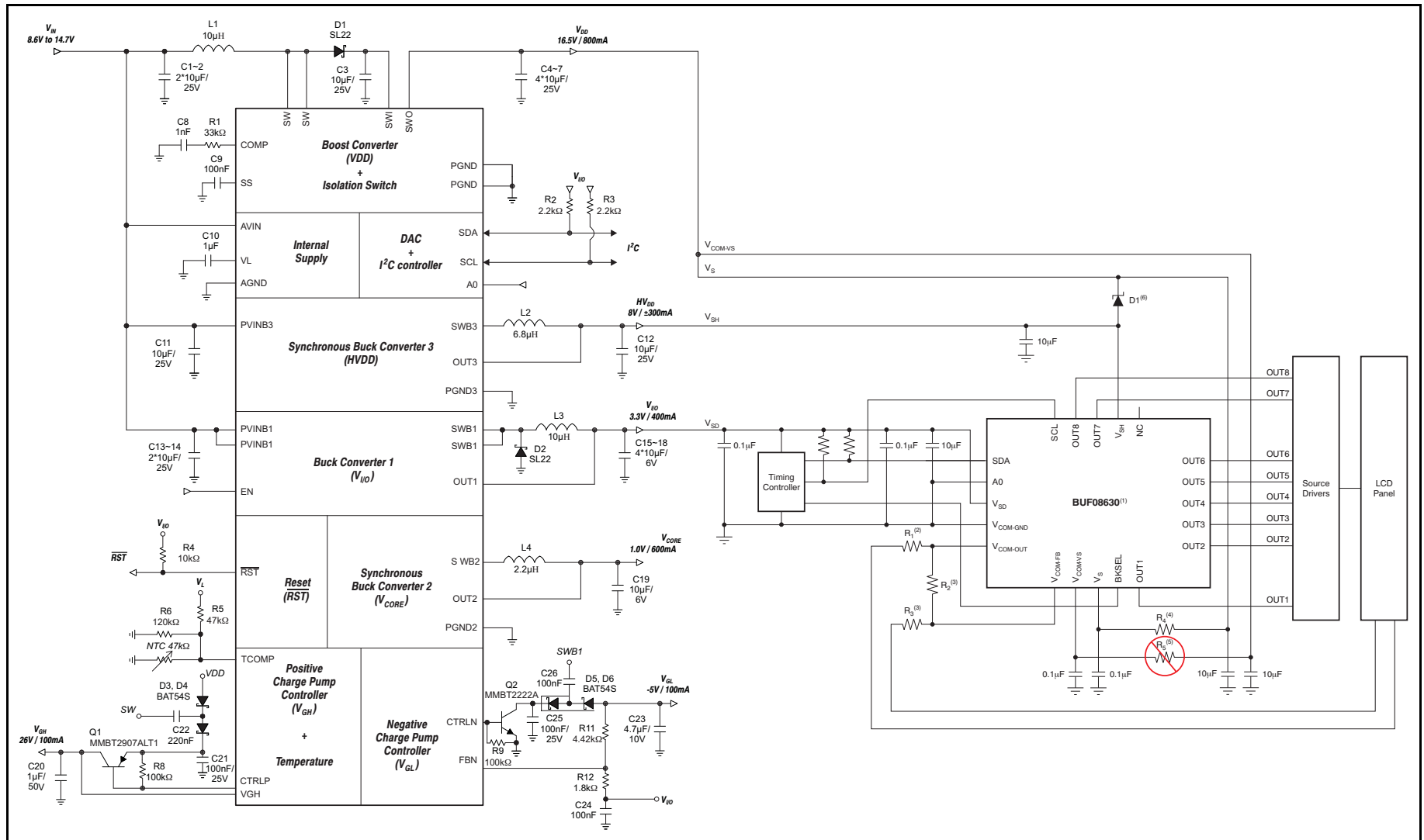

Figure 24. Typical Application Circuit using the TPS65168

TWO-WIRE BUS OVERVIEW

The BUF08630 communicates over an industry-standard, two-wire interface to receive data in slave mode. This model uses a two-wire, open-drain interface that supports multiple devices on a single bus. Bus lines are driven to a logic low level only. The device that initiates the communication is called a *master*, and the devices controlled by the master are *slaves*. The master generates the serial clock on the clock signal line (SCL), controls the bus access, and generates the START and STOP conditions.

To address a specific device, the master initiates a START condition by pulling the data signal line (SDA) from a high to a low logic level while SCL is high. All slaves on the bus shift in the slave address byte on the rising edge of SCL, with the last bit indicating whether a read or write operation is intended. During the ninth clock pulse, the slave being addressed responds to the master by generating an Acknowledge and pulling SDA low.

Data transfer is then initiated and eight bits of data are sent, followed by an Acknowledge bit. During data transfer, SDA must remain stable while SCL is high. Any change in SDA while SCL is high is interpreted as a START or STOP condition.

Once all data have been transferred, the master generates a STOP condition, indicated by pulling SDA from low to high while SCL is high. The BUF08630 can act only as a slave device; therefore, it never drives SCL. SCL is an input only for the BUF08630.

ADDRESSING THE BUF08630

The address of the BUF08630 is 111010x, where x is the state of the A0 pin. When the A0 pin is low, the device acknowledges on address 74h (1110100). If the A0 pin is high, the device acknowledges on address 75h (1110101). Table 1 shows the A0 pin settings and BUF08630 address options.

Other valid addresses are possible through a simple mask change. Contact your TI representative for information.

Table 1. Quick Reference of BUF08630 Addresses

DEVICE/COMPONENT	ADDRESS
BUF08630 ADDRESS	
A0 pin is low (device acknowledges on address 74h)	1110100
A0 pin is high (device acknowledges on address 75h)	1110101

DATA RATES

The two-wire bus operates in one of three speed modes:

- Standard: allows clock frequency up to 100 kHz;
- Fast: allows clock frequency up to 400 kHz; and
- High-speed mode (also called Hs mode): allows clock frequency up to 3.4 MHz.

The BUF08630 is fully compatible with all three modes. No special action is required to use the device in Standard or Fast modes, but High-speed mode must be activated. To activate High-speed mode, send a special address byte of 00001 xxx, with $SCL \leq 400$ kHz, following the START condition; where xxx are bits unique to the Hs-capable master, which can be any value. This byte is called the Hs master code. Table 2 provides a reference for the High-speed mode command code. (Note that this configuration is different from normal address bytes—the low bit does not indicate read/write status.) The BUF08630 responds to the High-speed command regardless of the value of these last three bits. The BUF08630 does not acknowledge this byte; the communication protocol prohibits acknowledgment of the Hs master code. Upon receiving a master code, the BUF08630 switches on its Hs mode filters, and communicates at up to 3.4 MHz. Additional high-speed transfers may be initiated without resending the Hs mode byte by generating a repeat START without a STOP. The BUF08630 switches out of Hs mode with the next STOP condition.

Table 2. Quick Reference of Command Codes

COMMAND	CODE
General-Call Reset	Address byte of 00h followed by a data byte of 06h.
High-Speed Mode	00001xxx, with $SCL \leq 400$ kHz; where xxx are bits unique to the Hs-capable master. This byte is called the Hs master code.

GENERAL-CALL RESET AND POWER-UP

The BUF08630 responds to a General-Call Reset, which is an address byte of 00h (0000 0000) followed by a data byte of 06h (0000 0110). The BUF08630 acknowledges both bytes. [Table 2](#) provides a reference for the General-Call Reset command code. Upon receiving a General-Call Reset, the BUF08630 performs a full internal reset, as though it had been powered off and then on. It always acknowledges the General-Call address byte of 00h (0000 0000), but does not acknowledge any General-Call data bytes other than 06h (0000 0110).

When the BUF08630 powers up, it automatically performs a reset. As part of the reset, the BUF08630 is configured for all outputs to change to the last programmed nonvolatile memory values, or 100000000 if the nonvolatile memory values have not been programmed.

Upon power-up or general-call reset, the DAC registers for channels 1 through 8 are set to 200 (default) that corresponds to mid-scale output for a 10-bit DAC. The high and low limit registers are set to 3FF and 000 respectively. Therefore, the limits are transparent if not programmed. Reset typically requires approximately 1ms.

OUTPUT VOLTAGE

Buffer output values are determined by the analog supply voltage (V_S) and the decimal value of the binary input code used to program that buffer. The value is calculated using [Equation 1](#):

$$V_{OUT} = V_S \times \left(\frac{\text{Code}}{1024} \right)$$

Where Code = 0 to 1023. (1)

The BUF08630 outputs are capable of a full-scale voltage output change in typically 5 μs ; no intermediate steps are required.

UPDATING THE DAC OUTPUT VOLTAGES

Because the BUF08630 features a double-buffered register structure, updating the digital-to-analog converter (DAC) and/or the V_{COM} register is not the same as updating the DAC and/or V_{COM} output voltage. There are two methods for updating the DAC/ V_{COM} output voltages.

Method 1: Method 1 is used when it is desirable to have the DAC/ V_{COM} output voltage change immediately after writing to a DAC register. For each write transaction, the master sets data bit 15 to a '1'. The DAC/ V_{COM} output voltage update occurs after receiving the 16th data bit for the currently-written register.

Method 2: Method 2 is used when it is desirable to have all DAC/ V_{COM} output voltages change at the same time. First, the master writes to the desired DAC/ V_{COM} channels with data bit 15 a '0'. Then, when writing the last desired DAC/ V_{COM} channel, the master sets data bit 15 to a '1'. All DAC/ V_{COM} channels are updated at the same time after receiving the 16th data bit.

NONVOLATILE MEMORY

BKSEL Pin

The BUF08630 has 16x rewrite capability of the nonvolatile memory. Additionally, the BUF08630 has the ability to store two distinct gamma curves in two different nonvolatile memory banks, each of which has 16x rewrite capability. One of the two available banks is selected using the external input pin, BKSEL. When this pin is low, BANK0 is selected; when this pin is high, BANK1 is selected.

When the BKSEL pin changes state, the BUF08630 loads values from the DAC registers to the DAC outputs for the newly chosen bank. At power-up, the state of the BKSEL pin determines which memory bank is selected.

The two-wire master also has the ability to update (acquire) the DAC registers with the last programmed nonvolatile memory values using software control. The bank to be acquired depends on the state of BKSEL.

General Acquire Command

A general acquire command is used to update all registers and DAC/V_{COM} outputs to the last programmed values stored in nonvolatile memory. A single-channel acquire command updates only the register and DAC/V_{COM} output of the DAC/V_{COM} corresponding to the DAC/V_{COM} address used in the single-channel acquire command.

These are the steps of the sequence to initiate a general channel acquire:

1. Be sure BKSEL is in its desired state and has been stable for at least 1ms.
2. Send a START condition on the bus.
3. Send the appropriate device address (based on A0) and the read/write bit = low. The BUF08630 acknowledges this byte.
4. Send a DAC/V_{COM} pointer address byte. Set bit D7 = 1 and D6 = 0. Bits D5-D0 are any valid DAC/V_{COM} address. Although the BUF08630 acknowledges 000000 through 010111, it stores and returns data only from these addresses:
 - 000000 through 000111
 - 010010
 It returns 0000 for reads from 001000 through 010001, and 010011 through 010111. See [Table 4](#) for valid DAC/V_{COM} addresses.
5. Send a STOP condition on the bus.

Approximately 750µs (±80 µs) after issuing this command, all DAC/V_{COM} registers and DAC/V_{COM} output voltages change to the respective, appropriate nonvolatile memory values.

Single-Channel Acquire Command

These are the steps to initiate a single-channel acquire:

1. Be sure BKSEL is in its desired state and has been stable for at least 1ms.
2. Send a START condition on the bus.
3. Send the device address (based on A0) and read/write bit = low. The BUF08630 acknowledges this byte.
4. Send a DAC/V_{COM} pointer address byte using the DAC/V_{COM} address corresponding to the output and register to update with the OTP memory value. Set bit D7 = 0 and D6 = 1. Bits D5-D0 are the DAC/V_{COM} address. Although the BUF08630 acknowledges 000000 through 010111, it stores and returns data only from these addresses:
 - 000000 through 000111
 - 010010
 It returns 0000 reads from 001000 through 010001, and 010011 through 010111. See [Table 4](#) for valid DAC/V_{COM} addresses.

5. Send a STOP condition on the bus.

Approximately 36µs (±4 µs) after issuing this command, the specified DAC/V_{COM} register and DAC/V_{COM} output voltage change to the appropriate memory value.

MaxBank

The BUF08630 can provide the user with the number of times the nonvolatile memory of a particular DAC/V_{COM} channel nonvolatile memory has been written to for the current memory bank. This information is provided by reading the register at pointer address 111111.

There are two ways to update the MaxBank register:

1. After initiating a single acquire command, the BUF08630 updates the MaxBank register with a code corresponding to how many times that particular channel memory has been written to.
2. Following a general acquire command, the BUF08630 updates the MaxBank register with a code corresponding to the maximum number of times the most used channel (OUT1-8 and V_{COM}S) has been written to.

MaxBank is a read-only register and is only updated by performing a general- or single-channel acquire.

[Table 3](#) shows the relationship between the number of times the nonvolatile memory has been programmed and the corresponding state of the MaxBank Register.

Table 3. MaxBank Details

NUMBER OF TIMES WRITTEN TO	RETURNS CODE
0	0000
1	0000
2	0001
3	0010
4	0011
5	0100
6	0101
7	0110
8	0111
9	1000
10	1001
11	1010
12	1011
13	1100
14	1101
15	1110
16	1111

Parity Error Correction

The BUF08630 provides single-bit parity error correction for data stored in the nonvolatile memory to provide increased reliability of the nonvolatile memory. If a single bit of nonvolatile memory for a channel fails, the BUF08630 corrects for it and updates the appropriate DAC with the intended value when its memory is acquired.

If more than one bit of nonvolatile memory for a channel fails, the BUF08630 does not correct for it, and updates the appropriate DAC/V_{COM} with the default value of 1000000000.

DIE_ID AND DIE_REV REGISTERS

The user can verify the presence of the BUF08630 in the system by reading from address 111101. The BUF08630 returns *0010000110110110* when read at this address.

The user can also determine the die revision of the BUF08630 by reading from register 111100. BUF08630 returns *0000000000000000* when a RevA die is present. RevB would be designated by *0000000000000001* and so on.

READ/WRITE OPERATIONS

Read and write operations can be done for a single DAC/V_{COM} or for multiple DAC/V_{COM}S. Writing to a DAC/V_{COM} register differs from writing to the nonvolatile memory. Bits D15–D14 of the most significant byte of data determines if data are written to the DAC/V_{COM} register or the nonvolatile memory.

Read/Write: DAC/V_{COM} Register (volatile memory)

The BUF08630 is able to read from a single DAC/V_{COM}, or multiple DAC/V_{COM}S, or write to the register of a single DAC/V_{COM} or multiple DAC/V_{COM}S in a single communication transaction. DAC pointer addresses begin with 000000 (which corresponds to OUT1) through 000111 (which corresponds to OUT8). The V_{COM} address is 010010.

Write commands are performed by setting the read/write bit low. Setting the read/write bit high performs a read transaction.

Writing: DAC/V_{COM} Register (Volatile Memory)

To write to a single DAC/V_{COM} register:

1. Send a START condition on the bus.
2. Send the device address and read/write bit = low. The BUF08630 acknowledges this byte.
3. Send a DAC/V_{COM} pointer address byte. Set bit D7 = 0 and D6 = 0. Bits D5–D0 are the DAC/V_{COM} address. Although the BUF08630 acknowledges 000000 through 010111, it stores and returns data only from these addresses:
 - 000000 through 000111
 - 010010
 It returns *0000* for reads from 001000 through 010001, and 010011 through 010111. See [Table 4](#) for valid DAC/V_{COM} addresses.
4. Send two bytes of data for the specified register. Begin by sending the most significant byte first (bits D15–D8, of which only bits D9 and D8 are used, and bits D15–D14 must not be 01), followed by the least significant byte (bits D7–D0). The register is updated after receiving the second byte.
5. Send a STOP or START condition on the bus.

The BUF08630 acknowledges each data byte. If the master terminates communication early by sending a STOP or START condition on the bus, the specified register is not updated. Updating the DAC/V_{COM} register is not the same as updating the DAC/V_{COM} output voltage; see the [Updating the DAC Output Voltages](#) section.

The process of updating multiple DAC/V_{COM} registers begins the same as when updating a single register. However, instead of sending a STOP condition after writing the addressed register, the master continues to send data for the next register. The BUF08630 automatically and sequentially steps through subsequent registers as additional data are sent. The process continues until all desired registers have been updated or a STOP or START condition is sent.

To write to multiple DAC/V_{COM} registers:

1. Send a START condition on the bus.
2. Send the device address and read/write bit = low. The BUF08630 acknowledges this byte.
3. Send either the OUT1 pointer address byte to start at the first DAC, or send the pointer address byte for whichever DAC/V_{COM} is the first in the sequence of DAC/V_{COM}s to be updated. The BUF08630 begins with this DAC/V_{COM} and steps through subsequent DAC/V_{COM}s in sequential order.
4. Send the bytes of data; begin by sending the most significant byte (bits D15–D8, of which only bits D9 and D8 have meaning, and bits D15–D14 must not be 01), followed by the least significant byte (bits D7–D0). The first two bytes are for the DAC/V_{COM} addressed in the previous step. The DAC/V_{COM} register is automatically updated after receiving the second byte. The next two bytes are for the following DAC/V_{COM}. That DAC/V_{COM} register is updated after receiving the fourth byte. This process continues until the registers of all following DAC/V_{COM}s have been updated. The BUF08630 accepts data for eight DACs, V_{COM} voltage, gain set, V_{COM} high limit, and V_{COM} low limit. Note that between these addresses, there are some unused addresses that must be skipped. For more details, see [Table 4](#). The write disable bit cannot be accessed using this method. It must be written to using *the write to a single DAC register procedure*.
5. Send a STOP or START condition on the bus.

The BUF08630 acknowledges each byte. To terminate communication, send a STOP or START condition on the bus. Only DAC registers that have received both bytes of data are updated.

Reading: DAC/V_{COM}/OTHER Register (Volatile Memory)

Reading a register returns the data stored in that DAC/V_{COM}/OTHER register.

To read a single DAC/V_{COM}/OTHER register:

1. Send a START condition on the bus.
2. Send the device address and read/write bit = low. The BUF08630 acknowledges this byte.
3. Send the DAC/V_{COM}/OTHER pointer address byte. Set bit D7 = 0 and D6 = 0; bits D5–D0 are the DAC/V_{COM}/OTHER address. NOTE: The BUF08630 stores and returns data only from these addresses:
 - 000000 through 000111
 - 010010
 - 111100 through 111111
 It returns 0000 for reads from 001000 through 010001, and 010011 through 010111. See [Table 4](#) for valid DAC/V_{COM}/OTHER addresses.
4. Send a START or STOP/START condition.
5. Send the correct device address and read/write bit = high. The BUF08630 acknowledges this byte.
6. Receive two bytes of data. They are for the specified register. The most significant byte (bits D15–D8) is received first; next is the least significant byte (bits D7–D0). In the case of DAC/V_{COM} channels, bits D15–D10 have no meaning.
7. Acknowledge after receiving the first byte.
8. Send a STOP or START condition on the bus or do not acknowledge the second byte to end the read transaction.

Communication may be terminated by sending a premature STOP or START condition on the bus, or by not acknowledging.

To read multiple registers:

1. Send a START condition on the bus.
2. Send the device address and read/write bit = low. The BUF08630 acknowledges this byte.
3. Send either the OUT1 pointer address byte to start at the first DAC, or send the pointer address byte for whichever register is the first in the sequence of DAC/V_{COM}s to be read. The BUF08630 begins with this DAC/V_{COM} and steps through subsequent DAC/V_{COM}s in sequential order.
4. Send a START or STOP/START condition on the bus.
5. Send the correct device address and read/write bit = high. The BUF08630 acknowledges this byte.
6. Receive two bytes of data. They are for the specified DAC/V_{COM}. The first received byte is the most significant byte (bits D15–D8; only bits D9 and D8 have meaning), next is the least significant byte (bits D7–D0).
7. Acknowledge after receiving each byte of data.
8. When all desired DACs have been read, send a STOP or START condition on the bus.

Communication may be terminated by sending a premature STOP or START condition on the bus, or by not sending the acknowledge bit. The reading of registers DieID, DieRev, and MaxBank is not supported in this mode of operation (these values must be read using the single register read method).

Write: Nonvolatile Memory for the DAC Register

The BUF08630 is able to write to the nonvolatile memory of a single DAC/V_{COM} in a single communication transaction. In contrast to the BUF20820, writing to multiple nonvolatile memory words in a single transaction is not supported. Valid DAC/V_{COM} pointer addresses begin with 000000 (which corresponds to OUT1) through 000111 (which corresponds to OUT8). The V_{COM} address is 010010.

When programming the nonvolatile memory, the analog supply voltage must be between 9 V and 20 V. Write commands are performed by setting the read/write bit low.

To write to a single nonvolatile register:

1. Send a START condition on the bus.
2. Send the device address and read/write bit = low. The BUF08630 acknowledges this byte. Although the BUF08630 acknowledges 000000 through 010111, it stores and returns data only from these addresses:
 - 000000 through 000111
 - 010010
 It returns 0000 for reads from 001000 through 010001, and 010011 through 010111. See [Table 4](#) for DAC/V_{COM} addresses.
3. Send a DAC/V_{COM} pointer address byte. Set bit D7 = 0 and D6 = 0. Bits D5–D0 are the DAC/V_{COM} address.
4. Send two bytes of data for the nonvolatile register of the specified DAC/V_{COM}. Begin by sending the most significant byte first (bits D15–D8, of which only bits D9 and D8 are data bits, and bits D15–D14 must be 01), followed by the least significant byte (bits D7–D0). The register is updated after receiving the second byte.
5. Send a STOP condition on the bus.

The BUF08630 acknowledges each data byte. If the master terminates communication early by sending a STOP or START condition on the bus, the specified nonvolatile register is not updated. Writing a nonvolatile register also updates the DAC/V_{COM} register and output voltage.

The DAC/V_{COM} register and DAC/V_{COM} output voltage are updated immediately, while the programming of the nonvolatile memory takes up to 250µs. Once a nonvolatile register write command has been issued, no communication with the BUF08630 should take place for at least 250 µs. Writing or reading over the serial interface while the nonvolatile memory is being written jeopardizes the integrity of the data being stored.

Read: Nonvolatile Memory for the DAC Register

To read the data present in nonvolatile register for a particular DAC/V_{COM} channel, the master must first issue a general acquire command, or a single acquire command with the appropriate DAC/V_{COM} channel chosen. This action updates both the DAC/V_{COM} register(s) and DAC/V_{COM} output voltage(s). The master may then read from the appropriate DAC/V_{COM} register as described earlier.

PROGRAMMABLE V_{COM} LIMITS

The BUF08630 V_{COM} output has a programmable high limit and low limit. The implementation and interface of these limits are the same as with the DAC registers. These registers are written to and read back through the two-wire bus. Addresses for limiters are 1E and 1F for the high limit and low limit, respectively. See [Table 4](#) for register pointer addresses.

Upon power-up or general-call reset, the DAC registers for V_{COM} are set to 200 (default) that corresponds to mid-scale output for a 10-bit DAC. The high and low limit registers are set to 3FF and 000 respectively. Therefore, the limits are transparent if not programmed. Reset typically requires approximately 1ms.

The BUF08630 uses double-buffered registers. The input of data is stored in the first layer. The input may be latched to the DAC output, depending upon application. The DACs update only when the second layer of latches are enabled.

The high and low limits can be programmed to any desired value to limit the V_{COM} output. The limit can be programmed before or after programming the

V_{COM} channel. Because the input of data is stored in the first layer of latches, the V_{COM} output is limited according to the following rule in either sequence:

1. If the V_{COM} OTP write is enabled, then the V_{COM} input is always stored in the OTP. Limit comparison happens only before the DAC output.
2. If the V_{COM} input is higher than the high limit, then the high limit is latched to the DAC output. Reading of the DAC register returns the high limit.
3. If the V_{COM} input is lower than the low limit, then the low limit is latched to the DAC output. Reading of the DAC register returns the low limit.
4. If the V_{COM} input is in between the high and low limit, then the programmed value is latched to DAC output. Reading of the DAC register returns the programmed value.
5. If the high limit is lower than the low limit, then the BUF08630 ignores the limits and latches the programmed value to the DAC output. Reading of the DAC register returns the programmed value.

There are two banks of OTP associated with each of the two limit registers. OTP operations on these two addresses are valid, just like OTP for DAC registers.

Table 4. Register Pointer Addresses

COMMENT	POINTER ADDRESS	REGISTER FUNCTION	READ/WRITE PERMISSION
Add control MSBs M1 and M0 (see Table 5)	000000	Channel 1 address	R/W
	000001	Channel 2 address	R/W
	000010	Channel 3 address	R/W
	000011	Channel 4 address	R/W
	000100	Channel 5 address	R/W
	000101	Channel 6 address	R/W
	000110	Channel 7 address	R/W
	000111	Channel 8 address	R/W
	001000	Reserved	R/W
	001001	Reserved	R/W
	001010	Reserved	R/W
	001011	Reserved	R/W
	001100	Reserved	R/W
	001101	Reserved	R/W
	001110	Reserved	R/W
	001111	Reserved	R/W
	010000	Reserved	R/W
	010001	Reserved	R/W
	010010	V _{COM} address	R/W
	010011	Reserved	R/W
	010100	Reserved	R/W
	010101	Reserved	R/W
	010110	Reserved	R/W
	010111	Reserved	R/W
	011000	Reserved	R/W
	011001	Reserved	R/W
	011010	Reserved	R/W
	011011	Reserved	R/W
	011100	Gain set	R/W
	011101	Reserved	R/W
	011110	V _{COM} high limit	R/W
	011111	V _{COM} low limit	R/W
100000	Reserved	R/W	
These special addresses are only valid in this exact format	00111100	Die revision	Read only
	00111101	Die ID	Read only
	00111111	MaxBank	Read only
	00111110	Memory raw data	Read only

Table 5. Control Bits M1 and M0

M0	M1	OPERATION
0	0	Write to DAC register if Write command is received. Read DAC Register if Read command is received.
0	1	Single acquire nonvolatile memory pointed to by the current register address.
1	0	General acquire nonvolatile memory for all DAC registers.
1	1	Not allowed.

ADJUSTABLE GAIN V_{COM}

The VCOM channel has eight internal, adjustable gain configurations that are selectable through the I²C bus, as shown in Table 6. The selectable gains include buffer gains of 1, 2, 3, 4, 5, and 6; a buffer

configuration; and an external user-defined, gain-select configuration, as shown in Table 7. The internal configuration uses the topology depicted in Figure 25 to achieve the different gain selections that are selected by setting internal switches 1 through 8.

Table 6. V_{COM} Gain Set Register Description

REGISTER ADDRESS	REGISTER NAME	REGISTER DESCRIPTION	NUMBER OF BITS	VOLATILE MEMORY WRITE TIMES	POWER-ON RESET VALUE	NONVOLATILE MEMORY WRITE TIMES
1Ch	VcomGain	Set V_{COM} gain	8	Unlimited	1 ⁽¹⁾	16

(1) Power-on reset requires 1.2ms.

Table 7. V_{COM} Gain Set Register (Address = 1Ch)

B15	B14	B13	B12	B11	B10	B9	B8	B7	B6	B5	B4	B3	B2	B1	B0	GAIN
1	0	0	0	0	0	0	0	0	0	0	0	0	0	0	1	+1
1	0	0	0	0	0	0	0	0	0	0	0	0	0	1	0	-1
1	0	0	0	0	0	0	0	0	0	0	0	0	1	0	0	-2
1	0	0	0	0	0	0	0	0	0	0	0	1	0	0	0	-3
1	0	0	0	0	0	0	0	0	0	0	1	0	0	0	0	-4
1	0	0	0	0	0	0	0	0	0	1	0	0	0	0	0	-5
1	0	0	0	0	0	0	0	0	1	0	0	0	0	0	0	-6
1	0	0	0	0	0	0	0	1	0	0	0	0	0	0	0	Set by external resistor

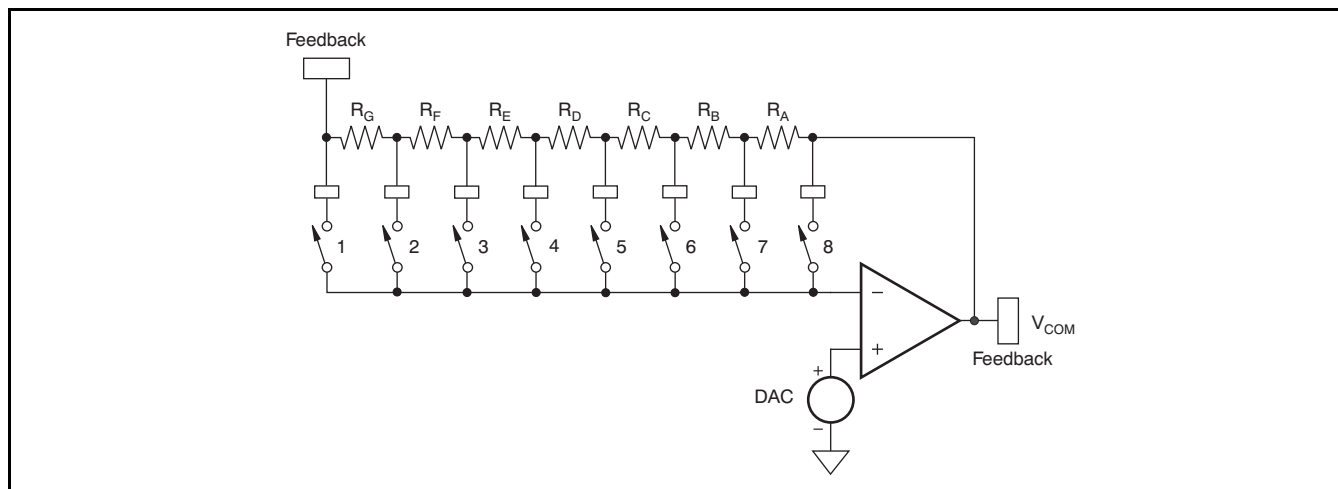

Figure 25. Feedback Configuration Topology

Table 8 lists the approximate values ($\pm 15\%$) of the internal resistors in the feedback configuration depicted in Figure 25, for a total resistive value of approximately $13\text{ k}\Omega$ ($\pm 15\%$).

Table 8. Feedback Resistor Values

RESISTOR	TYPICAL VALUE ⁽¹⁾ (Ω)
R _A	6502.5
R _B	2165
R _C	1083
R _D	651.25
R _E	432.5
R _F	310.625
R _G	1858.75

(1) All values are $\pm 15\%$.

For switch positions 2, 3, 4, 5, 6, and 7, the buffer is configured in an internal inverting gain, as shown in Figure 26.

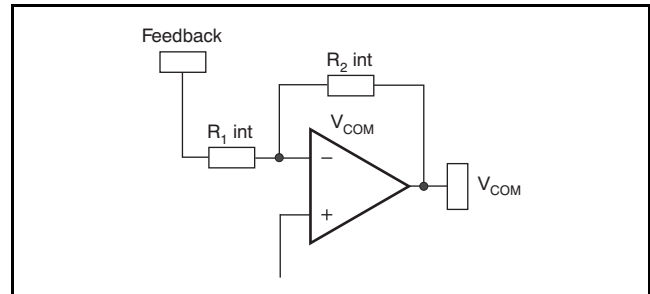
Figure 26. Configuration for Switch Positions 2, 3, 4, 5, 6, 7
Table 9. Gain Select Resistor Ratio ($\pm 15\%$)

GAIN	VALUE OF R ₂ BASED ON SWITCH POSITIONS	VALUE OF R ₁ BASED ON SWITCH POSITIONS
G = 1	6502 Ω	6501 Ω
G = 2	8667 Ω	4336 Ω
G = 3	9750 Ω	3253 Ω
G = 4	10401 Ω	2601 Ω
G = 5	10834 Ω	2169 Ω
G = 6	11144 Ω	1858 Ω

Table 10 shows the theoretical gain values of the inverting configuration using the internal resistors, $\pm 15\%$.

Table 10. Gain Equation

GAIN	RATIO	TYPICAL VALUE
G = 1	$-R_2/R_1$	-1.00021
G = 2	$-R_2/R_1$	-1.9989
G = 3	$-R_2/R_1$	-2.99727
G = 4	$-R_2/R_1$	-3.99779
G = 5	$-R_2/R_1$	-4.99418
G = 6	$-R_2/R_1$	-5.9959

A buffer configuration is achieved using switch position 8 as indicated in Figure 27

An external user-selectable gain configuration is achieved using switch position 1, as indicated in Figure 28. By using a single external gain resistor value and the internal values of the resistor string, a wide range of selectable gains can be achieved using the internal switch configuration.

Table 11 shows the possible gains that can be achieved with a single 1-k Ω external resistor for each of the internal switch selections.

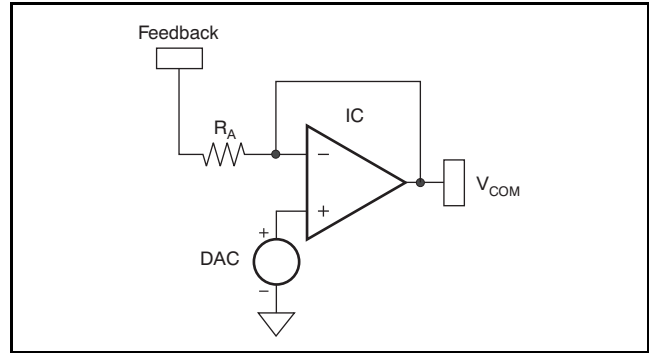

Figure 27. Configuration for Switch Position 8

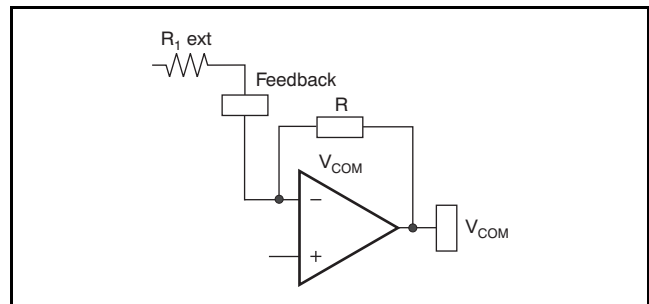

Figure 28. Configuration for Switch Position 1

Table 11. Possible Gains Using a 1-k Ω External Resistor

EXTERNAL RESISTANCE	INTERNAL RESISTANCE	GAIN	SWITCH POSITION
$R_1 \text{ ext} = 1000 \Omega$	$R = 13003.63 \Omega$	-13.0036	1
$R_1 \text{ ext} + R_{\text{INT}} = 2858.75 \Omega$	$R = 11144.88 \Omega$	-3.89851	2
$R_1 \text{ ext} + R_{\text{INT}} = 3169.375 \Omega$	$R = 10834.25 \Omega$	-3.41842	3
$R_1 \text{ ext} + R_{\text{INT}} = 3601.875 \Omega$	$R = 10401.75 \Omega$	-2.88787	4
$R_1 \text{ ext} + R_{\text{INT}} = 4253.125 \Omega$	$R = 9750.5 \Omega$	-2.29255	5
$R_1 \text{ ext} + R_{\text{INT}} = 5336.125 \Omega$	$R = 8667.5 \Omega$	-1.62431	6
$R_1 \text{ ext} + R_{\text{INT}} = 7501.125 \Omega$	$R = 6502.5 \Omega$	-0.86687	7

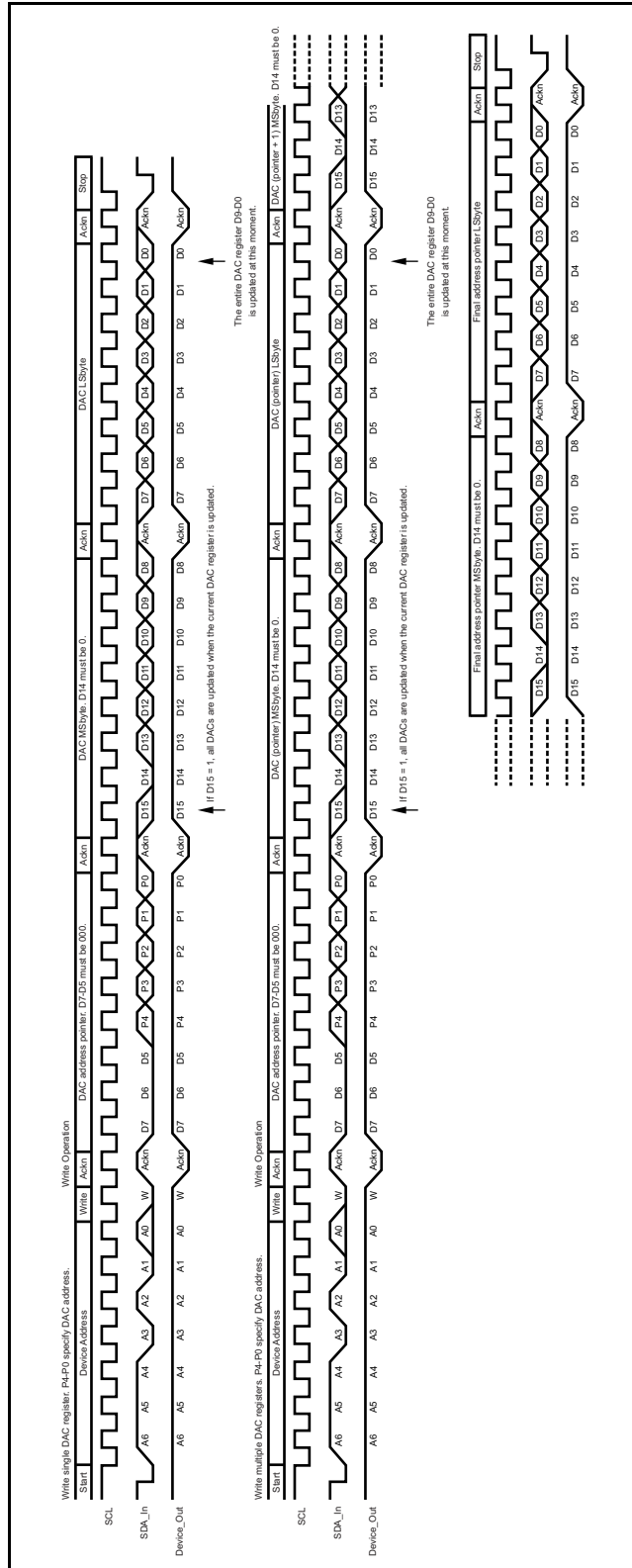

Figure 29. Write DAC Register Timing

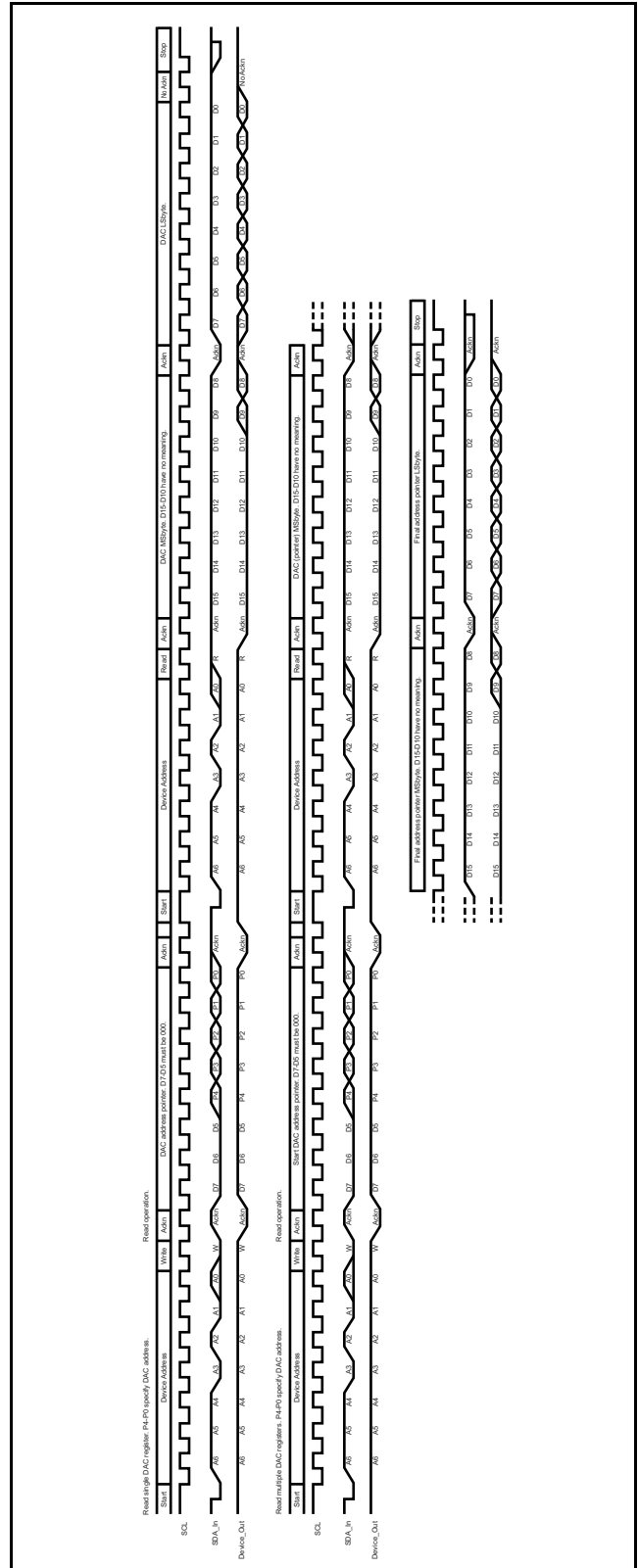

Figure 30. Read Register Timing

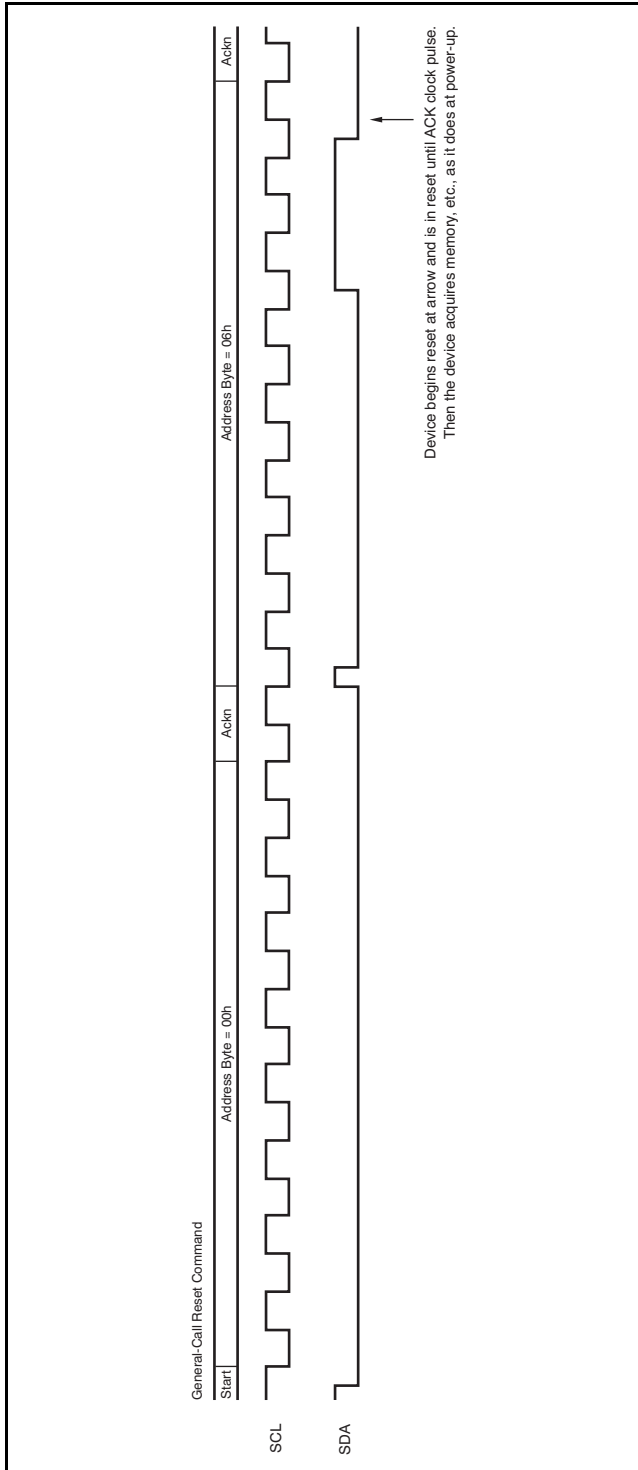

Figure 33. General-Call Reset Timing

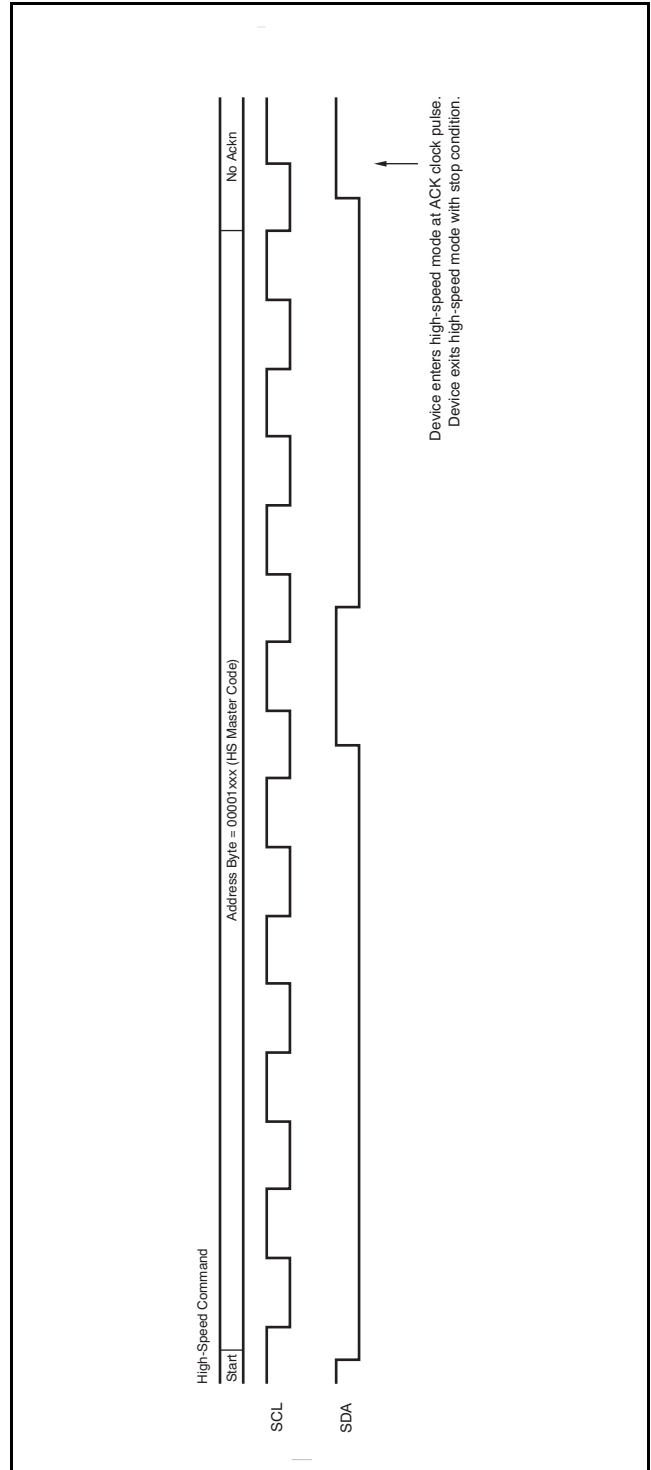

Figure 34. High-Speed Mode Timing

END-USER SELECTED GAMMA CONTROL

Because the BUF08630 has two banks of nonvolatile memory, it is well-suited for providing two levels of gamma control by using the BKSEL pin, as shown in Figure 35. When the state of the BKSEL pin changes, the BUF08630 updates all nine programmable buffer outputs simultaneously after 10 μ s, typical.

To update all nine programmable output voltages simultaneously via hardware, toggle the BKSEL pin to switch between Gamma Curve 0 (stored in Bank0) and Gamma Curve 1 (stored in Bank1).

All DAC/ V_{COM} registers and output voltages are updated simultaneously after approximately 10 μ s, typical.

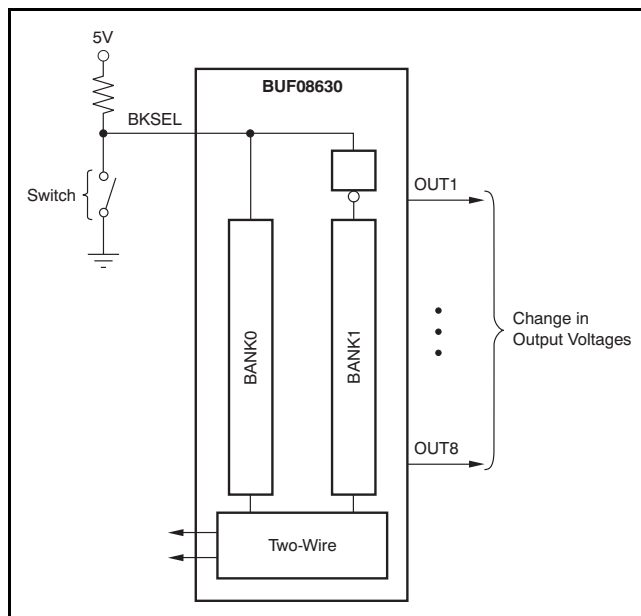

Figure 35. Gamma Control

DYNAMIC GAMMA CONTROL

Dynamic gamma control is a technique used to improve the picture quality in LCD television applications. This technique typically requires switching gamma curves between frames. Using the BKSEL pin to switch between two gamma curves does not often provide good results because of the 750 μ s required to transfer the data from the nonvolatile memory to the DAC register. However, dynamic gamma control can still be accomplished by storing two gamma curves in an external EEPROM and writing directly to the DAC register (volatile).

The double register input structure saves programming time by allowing updated DAC values to be pre-stored into the first register bank. Storage of this data can occur while a picture is still being displayed. Because the data are only stored into the first register bank, the DAC/ V_{COM} output values

remain unchanged—the display is unaffected. At the beginning or the end of a picture frame, the DAC/ V_{COM} outputs (and therefore, the gamma voltages) can be quickly updated by writing a '1' in bit 15 of any DAC/ V_{COM} register. For details on the operation of the double register input structure, see the *Updating the DAC Output Voltages* section.

To update all nine programmable output voltages simultaneously via software, perform the following actions:

STEP 1: Write to registers 1–9 with bit 15 always '0'.

STEP 2: Write any DAC/ V_{COM} register a second time with identical data. Make sure that bit 15 is set to '1'. All DAC/ V_{COM} channels are updated simultaneously after receiving the last bit of data.

OUTPUT PROTECTION

The BUF08630 output stages can safely source and sink the current levels indicated in Figure 1 and Figure 2. However, there are other modes where precautions must be taken to prevent the output stages from being damaged by excessive current flow. The outputs (OUT1 through OUT8, and V_{COM}) include ESD protection diodes, as shown in Figure 36. Normally, these diodes do not conduct and are passive during typical device operation. However, unusual operating conditions can occur where the diodes may conduct, potentially subjecting them to high, even damaging current levels. These conditions are most likely to occur when a voltage applied to an output exceeds $(V_S) + 0.5$ V, or drops below GND – 0.5 V.

One common scenario where this condition can occur is when the output pin is connected to a sufficiently large capacitor, and the BUF08630 power-supply source (V_S) is suddenly removed. Removing the power-supply source allows the capacitor to discharge through the current-steering diodes. The energy released during the high current flow period causes the power dissipation limits of the diode to be exceeded. Protection against the high current flow may be provided by placing a Schottky diode as shown in Figure 36. This diode must be capable of discharging the capacitor without allowing more than 0.5V to develop across the internal ESD current steering diodes.

CAUTION

Do not connect large capacitors to the output of the gamma buffers without connecting a Schottky diode. Otherwise, the device will be damaged.

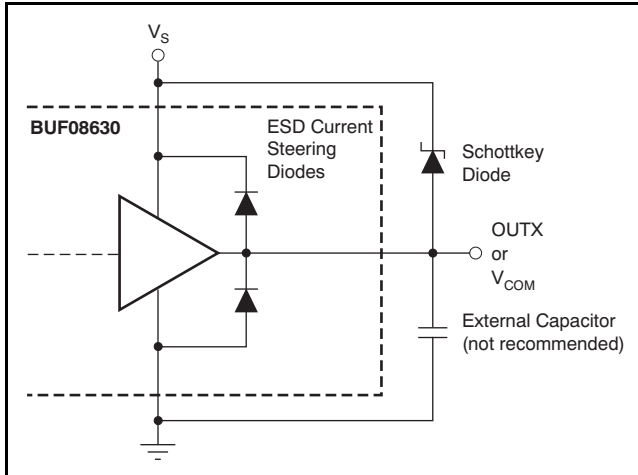

Figure 36. Output Pins ESD Protection Current-Steering Diodes

APPLICATION INFORMATION

Figure 37 shows a typical application circuit.

GENERAL POWERPAD DESIGN CONSIDERATIONS

The BUF08630 is available in a thermally-enhanced PowerPAD package. The exposed thermal die must be soldered to the PCB using thermal vias. Refer to Texas Instruments' application report [SLAU271, QFN/SON PCB Attachment](#).

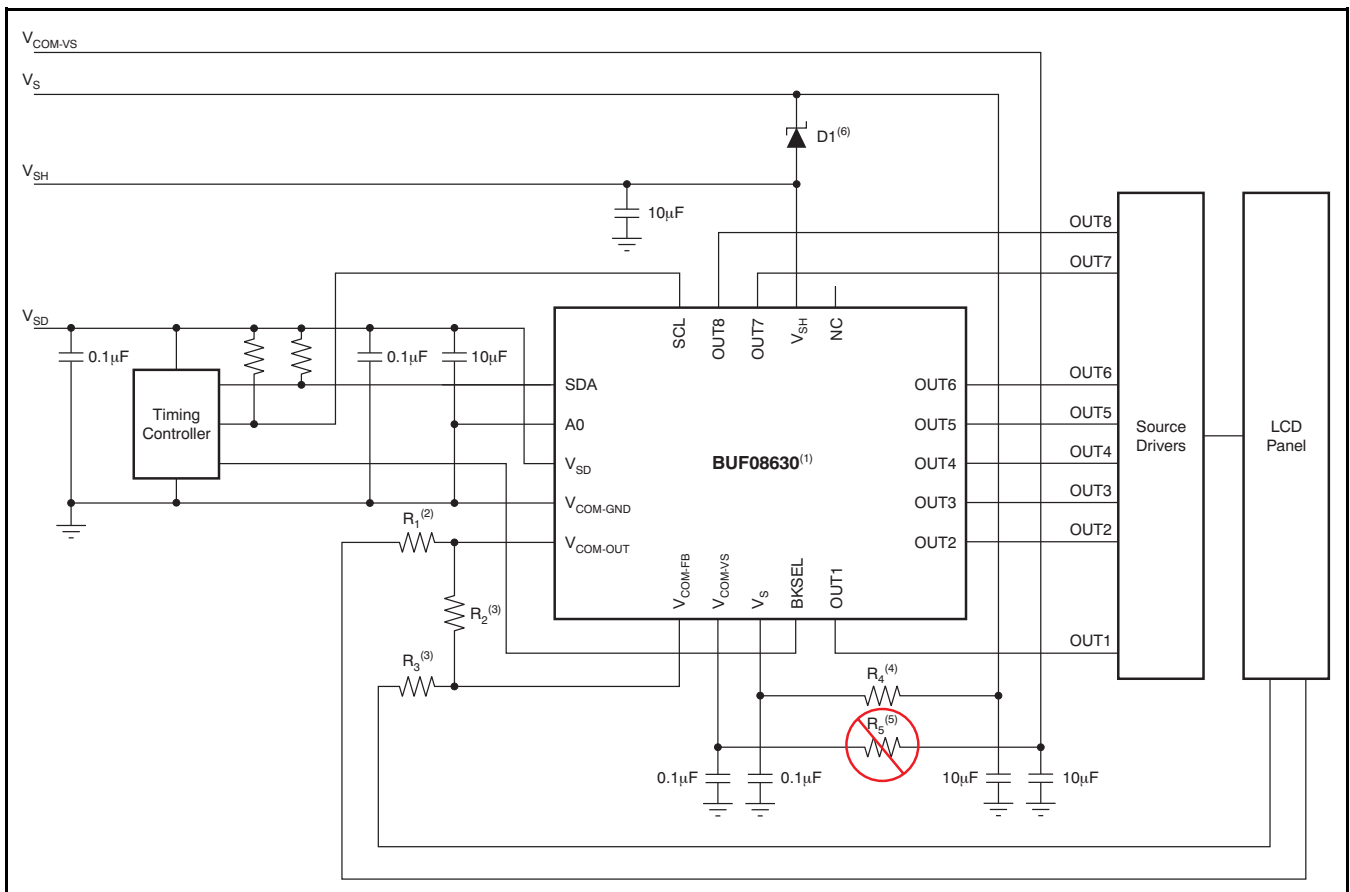

- (1) Exposed thermal pad must be connected to GND.
- (2) R_1 should be chosen for best stability.
- (3) R_2 and R_3 are not needed if internal gain is used.
- (4) R_4 must not exceed 10 Ω .
- (5) R_5 must never be used. V_{COM} can provide up to 400mA. A 10- Ω resistor would cause a 4V drop to the device.
- (6) $D1$ should be used if there is any possibility of V_{SH} exceeding V_S .

Figure 37. Typical Application Circuit

REVISION HISTORY

NOTE: Page numbers for previous revisions may differ from page numbers in the current version.

Changes from Original (October 2010) to Revision A	Page
• Changed data sheet associated to BUF08630 device from 1-page (SBOS535) to this full PDF	1
• Updated step 4 in the <i>To write to multiple DAC/V_{COM} registers</i> subsection	16
• Updated Table 4	19
• Changed Figure 29	23
• Changed Figure 30	23

PACKAGING INFORMATION

Orderable Device	Status (1)	Package Type	Package Drawing	Pins	Package Qty	Eco Plan (2)	Lead/Ball Finish	MSL Peak Temp (3)	Op Temp (°C)	Top-Side Markings (4)	Samples
BUF08630RGWR	ACTIVE	VQFN	RGW	20	3000	Green (RoHS & no Sb/Br)	CU NIPDAU	Level-2-260C-1 YEAR	-40 to 95	BUF 08630	Samples
BUF08630RGWT	ACTIVE	VQFN	RGW	20	250	Green (RoHS & no Sb/Br)	CU NIPDAU	Level-2-260C-1 YEAR	-40 to 95	BUF 08630	Samples

(1) The marketing status values are defined as follows:

ACTIVE: Product device recommended for new designs.

LIFEBUY: TI has announced that the device will be discontinued, and a lifetime-buy period is in effect.

NRND: Not recommended for new designs. Device is in production to support existing customers, but TI does not recommend using this part in a new design.

PREVIEW: Device has been announced but is not in production. Samples may or may not be available.

OBSOLETE: TI has discontinued the production of the device.

(2) Eco Plan - The planned eco-friendly classification: Pb-Free (RoHS), Pb-Free (RoHS Exempt), or Green (RoHS & no Sb/Br) - please check <http://www.ti.com/productcontent> for the latest availability information and additional product content details.

TBD: The Pb-Free/Green conversion plan has not been defined.

Pb-Free (RoHS): TI's terms "Lead-Free" or "Pb-Free" mean semiconductor products that are compatible with the current RoHS requirements for all 6 substances, including the requirement that lead not exceed 0.1% by weight in homogeneous materials. Where designed to be soldered at high temperatures, TI Pb-Free products are suitable for use in specified lead-free processes.

Pb-Free (RoHS Exempt): This component has a RoHS exemption for either 1) lead-based flip-chip solder bumps used between the die and package, or 2) lead-based die adhesive used between the die and leadframe. The component is otherwise considered Pb-Free (RoHS compatible) as defined above.

Green (RoHS & no Sb/Br): TI defines "Green" to mean Pb-Free (RoHS compatible), and free of Bromine (Br) and Antimony (Sb) based flame retardants (Br or Sb do not exceed 0.1% by weight in homogeneous material)

(3) MSL, Peak Temp. -- The Moisture Sensitivity Level rating according to the JEDEC industry standard classifications, and peak solder temperature.

(4) Multiple Top-Side Markings will be inside parentheses. Only one Top-Side Marking contained in parentheses and separated by a "~" will appear on a device. If a line is indented then it is a continuation of the previous line and the two combined represent the entire Top-Side Marking for that device.

Important Information and Disclaimer: The information provided on this page represents TI's knowledge and belief as of the date that it is provided. TI bases its knowledge and belief on information provided by third parties, and makes no representation or warranty as to the accuracy of such information. Efforts are underway to better integrate information from third parties. TI has taken and continues to take reasonable steps to provide representative and accurate information but may not have conducted destructive testing or chemical analysis on incoming materials and chemicals. TI and TI suppliers consider certain information to be proprietary, and thus CAS numbers and other limited information may not be available for release.

In no event shall TI's liability arising out of such information exceed the total purchase price of the TI part(s) at issue in this document sold by TI to Customer on an annual basis.

TAPE AND REEL INFORMATION

QUADRANT ASSIGNMENTS FOR PIN 1 ORIENTATION IN TAPE

*All dimensions are nominal

Device	Package Type	Package Drawing	Pins	SPQ	Reel Diameter (mm)	Reel Width W1 (mm)	A0 (mm)	B0 (mm)	K0 (mm)	P1 (mm)	W (mm)	Pin1 Quadrant
BUF08630RGWR	VQFN	RGW	20	3000	330.0	12.4	5.3	5.3	1.1	8.0	12.0	Q2
BUF08630RGWT	VQFN	RGW	20	250	180.0	12.4	5.3	5.3	1.1	8.0	12.0	Q2

TAPE AND REEL BOX DIMENSIONS

*All dimensions are nominal

Device	Package Type	Package Drawing	Pins	SPQ	Length (mm)	Width (mm)	Height (mm)
BUF08630RGWR	VQFN	RGW	20	3000	367.0	367.0	35.0
BUF08630RGWT	VQFN	RGW	20	250	210.0	185.0	35.0

RGW (S-PVQFN-N20)

PLASTIC QUAD FLATPACK NO-LEAD

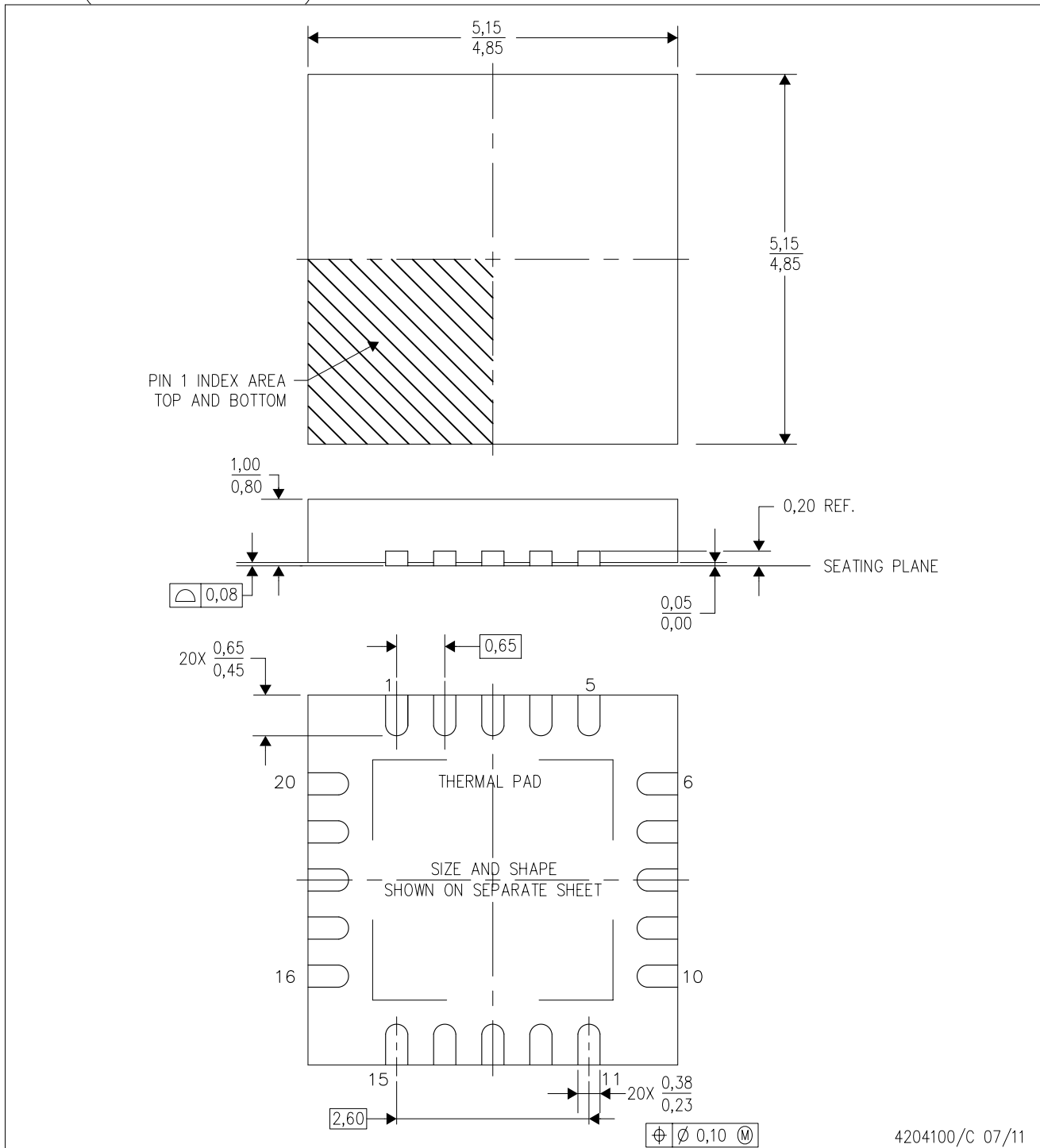

- NOTES:
- A. All linear dimensions are in millimeters. Dimensioning and tolerancing per ASME Y14.5-1994.
 - B. This drawing is subject to change without notice.
 - C. Quad Flat pack, No-leads (QFN) package configuration
 - D. The package thermal pad must be soldered to the board for thermal and mechanical performance.
 - E. See the additional figure in the Product Data Sheet for details regarding the exposed thermal pad features and dimensions.
 - F. Falls within JEDEC MO-220.

THERMAL PAD MECHANICAL DATA

RGW (S-PVQFN-N20)

PLASTIC QUAD FLATPACK NO-LEAD

THERMAL INFORMATION

This package incorporates an exposed thermal pad that is designed to be attached directly to an external heatsink. The thermal pad must be soldered directly to the printed circuit board (PCB). After soldering, the PCB can be used as a heatsink. In addition, through the use of thermal vias, the thermal pad can be attached directly to the appropriate copper plane shown in the electrical schematic for the device, or alternatively, can be attached to a special heatsink structure designed into the PCB. This design optimizes the heat transfer from the integrated circuit (IC).

For information on the Quad Flatpack No-Lead (QFN) package and its advantages, refer to Application Report, QFN/SON PCB Attachment, Texas Instruments Literature No. SLUA271. This document is available at www.ti.com.

The exposed thermal pad dimensions for this package are shown in the following illustration.

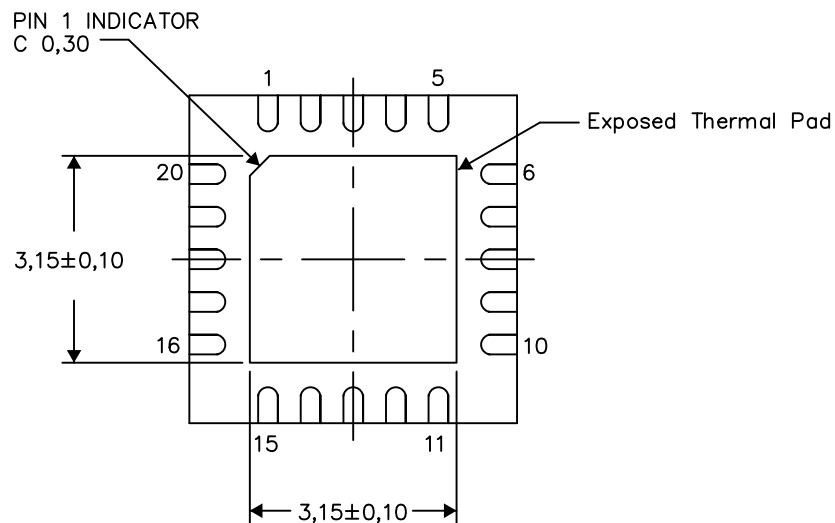

Exposed Thermal Pad Dimensions

4206352-2/M 06/15

NOTE: All linear dimensions are in millimeters

RGW (S-PVQFN-N20)

PLASTIC QUAD FLATPACK NO-LEAD

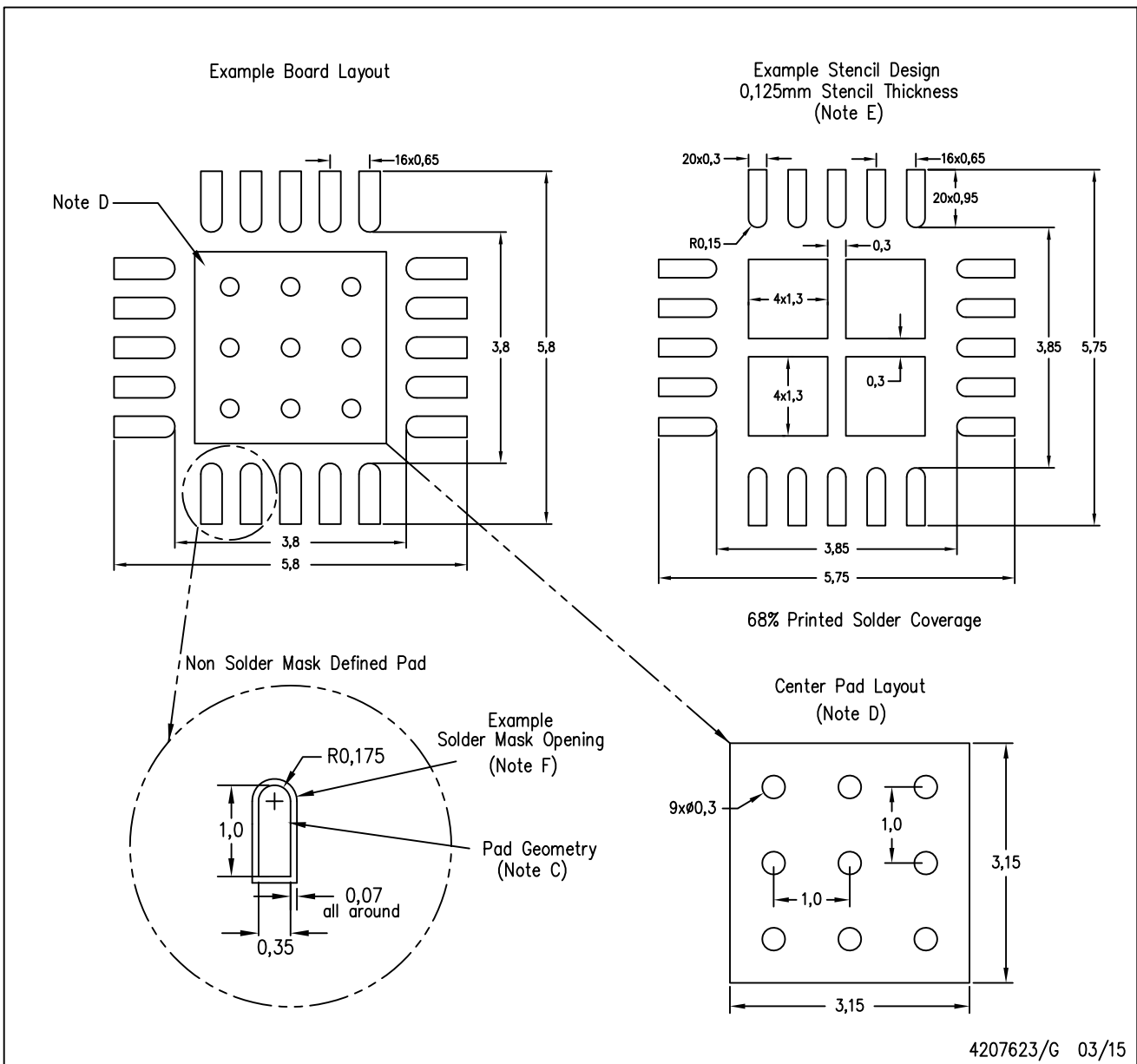

- NOTES:
- All linear dimensions are in millimeters.
 - This drawing is subject to change without notice.
 - Publication IPC-7351 is recommended for alternate designs.
 - This package is designed to be soldered to a thermal pad on the board. Refer to Application Note, QFN Packages, Texas Instruments Literature No. SLUA271, and also the Product Data Sheets for specific thermal information, via requirements, and recommended board layout. These documents are available at www.ti.com <<http://www.ti.com>>.
 - Laser cutting apertures with trapezoidal walls and also rounding corners will offer better paste release. Customers should contact their board assembly site for stencil design recommendations. Refer to IPC 7525 for stencil design considerations.
 - Customers should contact their board fabrication site for solder mask tolerances.

IMPORTANT NOTICE AND DISCLAIMER

TI PROVIDES TECHNICAL AND RELIABILITY DATA (INCLUDING DATASHEETS), DESIGN RESOURCES (INCLUDING REFERENCE DESIGNS), APPLICATION OR OTHER DESIGN ADVICE, WEB TOOLS, SAFETY INFORMATION, AND OTHER RESOURCES "AS IS" AND WITH ALL FAULTS, AND DISCLAIMS ALL WARRANTIES, EXPRESS AND IMPLIED, INCLUDING WITHOUT LIMITATION ANY IMPLIED WARRANTIES OF MERCHANTABILITY, FITNESS FOR A PARTICULAR PURPOSE OR NON-INFRINGEMENT OF THIRD PARTY INTELLECTUAL PROPERTY RIGHTS.

These resources are intended for skilled developers designing with TI products. You are solely responsible for (1) selecting the appropriate TI products for your application, (2) designing, validating and testing your application, and (3) ensuring your application meets applicable standards, and any other safety, security, or other requirements. These resources are subject to change without notice. TI grants you permission to use these resources only for development of an application that uses the TI products described in the resource. Other reproduction and display of these resources is prohibited. No license is granted to any other TI intellectual property right or to any third party intellectual property right. TI disclaims responsibility for, and you will fully indemnify TI and its representatives against, any claims, damages, costs, losses, and liabilities arising out of your use of these resources.

TI's products are provided subject to TI's Terms of Sale (www.ti.com/legal/termsofsale.html) or other applicable terms available either on ti.com or provided in conjunction with such TI products. TI's provision of these resources does not expand or otherwise alter TI's applicable warranties or warranty disclaimers for TI products.

Mailing Address: Texas Instruments, Post Office Box 655303, Dallas, Texas 75265
Copyright © 2018, Texas Instruments Incorporated

Looking for pricing, stock, or lifecycle information?

Click below to explore more details on WIN SOURCE:

 [View BUF08630RGWR on WIN SOURCE](#)

 [Texas Instruments](#) Information

Optimize Your Supply Chain with WIN SOURCE Solutions

-  Global Sourcing Solution
-  Obsolete Management
-  Cost Control Management
-  Shortage Management
-  Alternative Solution
-  Excess Inventory Management