



**THE DATASHEET OF
BUF01901AIDRCR**





Programmable Voltage Source with Memory

FEATURES

- 10-BIT RESOLUTION
- RAIL-TO-RAIL OUTPUT
- ONBOARD NONVOLATILE MEMORY
- I_{OUT} : 100mA
- LOW SUPPLY CURRENT: 900 μ A
- SUPPLY VOLTAGE: 7V to 18V
- DIGITAL SUPPLY: 2.0V to 5.5V
- INDUSTRY-STANDARD, TWO-WIRE INTERFACE
- HIGH ESD RATING:
2kV HBM, 500V CDM

APPLICATIONS

- LCD PANEL V_{COM} CALIBRATION
- LCD PANEL BRIGHTNESS AND CONTRAST CONTROL
- POTENTIOMETER REPLACEMENT
- MOTOR DRIVE
- PROGRAMMABLE POWER SUPPLY
- PROGRAMMABLE OFFSET ADJUSTMENT
- ACTUATOR CONTROL

BUF01900, BUF01901 RELATED PRODUCTS

FEATURES	PRODUCT
22V High Supply Voltage Gamma Buffers	BUF11705
12--Channel Programmable Buffer, 10-Bit, V_{COM}	BUF12800
20-Channel Programmable Buffer, 10-Bit, V_{COM}	BUF20800
16-Channel Programmable Buffer with Memory	BUF16820
20-Channel Programmable Buffer with Memory	BUF20820

DESCRIPTION

The BUF01900 and BUF01901 provide a programmable voltage output with 10-bit resolution. Programming of the output occurs through an industry-standard, two-wire serial interface. Once the correct V_{COM} voltage is established it can easily be stored into the integrated nonvolatile memory.

An initial output voltage and adjustment range can be set by an external resistor-divider. With its large output current capability (up to 100mA), the BUF01900 and BUF01901 are ideally suited as programmable V_{COM} calibrators in LCD panels.

The BUF01901 has the digital-to-analog converter (DAC) output brought out directly. It has a slightly lower cost than the BUF01900, and works very well with the integrated V_{COM} in traditional gamma buffers such as the BUFxx702, BUFxx703, BUFxx704 and BUF11705.

The BUF01900 and BUF01901 are both available in TSSOP-8 and 3mm x 3mm DFN-10 packages. The DFN-10 package (only 0.9mm in height) is especially well-suited for notebook computers. Both devices are specified from -40°C to $+85^{\circ}\text{C}$.

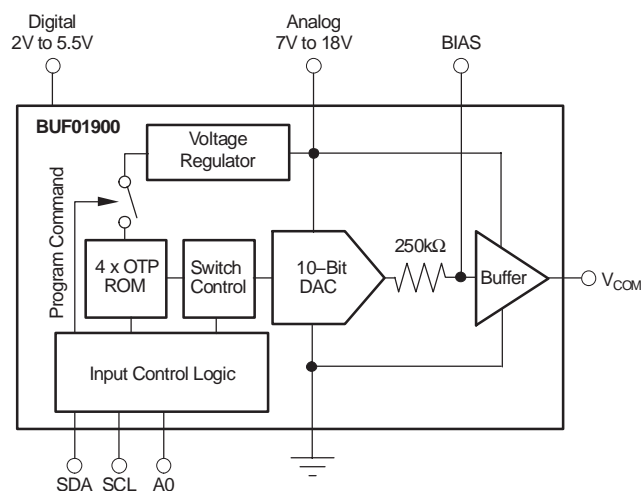

Please be aware that an important notice concerning availability, standard warranty, and use in critical applications of Texas Instruments semiconductor products and disclaimers thereto appears at the end of this data sheet.

PowerPAD is a registered trademark of Texas Instruments. All other trademarks are the property of their respective owners.



This integrated circuit can be damaged by ESD. Texas Instruments recommends that all integrated circuits be handled with appropriate precautions. Failure to observe proper handling and installation procedures can cause damage.

ESD damage can range from subtle performance degradation to complete device failure. Precision integrated circuits may be more susceptible to damage because very small parametric changes could cause the device not to meet its published specifications.

ABSOLUTE MAXIMUM RATINGS(1)

Supply Voltage, V_S	+20V
Supply Voltage, V_{SD}	+6V
Signal Input Terminals, BIAS:	
Voltage	-0.5V to $V_S + 0.5V$
SCL, SDA, A0, A1: Voltage	-0.5V to +6V
Current	$\pm 10mA$
Output Short Circuit(2)	Continuous
Operating Temperature	-40°C to +95°C
Storage Temperature	-65°C to +150°C
Junction Temperature	+125°C
ESD Rating:	
Human Body Model (HBM)	2000V
Charged-Device Model (CDM)	500V

(1) Stresses above these ratings may cause permanent damage. Exposure to absolute maximum conditions for extended periods may degrade device reliability. These are stress ratings only, and functional operation of the device at these or any other conditions beyond those specified is not supported.

(2) Short-circuit to ground.

ORDERING INFORMATION(1)

PRODUCT	PACKAGE-LEAD	PACKAGE DESIGNATOR	PACKAGE MARKING
BUF01900	DFN-10	DRC	BOO
BUF01900	TSSOP-8	PW	F01900
BUF01901	DFN-10	DRC	BOP
BUF01901	TSSOP-8	PW	F01901

(1) For the most current package and ordering information, see the Package Option Addendum at the end of this document, or see the TI web site at www.ti.com.

PIN CONFIGURATIONS

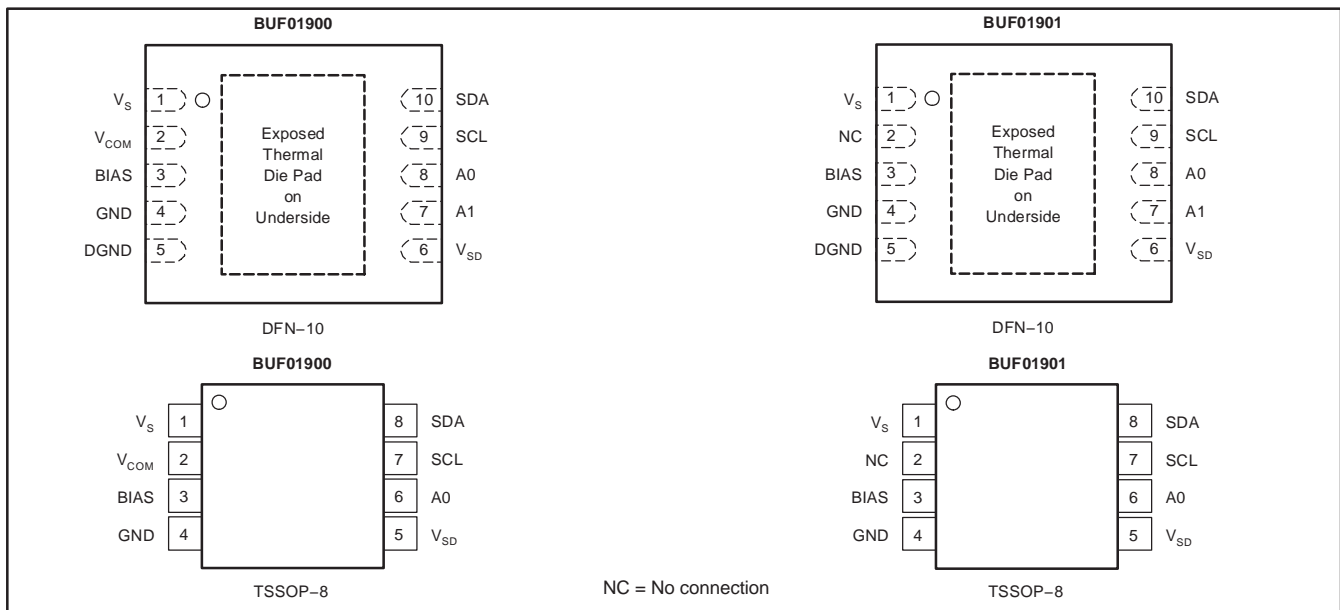

ELECTRICAL CHARACTERISTICS

Boldface limits apply over the specified temperature range, $T_A = -40^\circ\text{C}$ to $+85^\circ\text{C}$.

At $T_A = +25^\circ\text{C}$, $V_S = 18\text{V}$, $V_{SD} = 5\text{V}$, $R_L = 1.5\text{k}\Omega$ connected to ground, and $C_L = 200\text{pF}$, unless otherwise noted.

PARAMETER	CONDITIONS	BUF01900, BUF01901			UNIT
		MIN	TYP	MAX	
ANALOG					
V_{COM} Output Swing ⁽¹⁾	Sourcing 10mA, Code 1023	17.7	17.8		V
	Sinking 10mA, Code 00		0.6	1	V
	Sourcing 100mA, Code 1023	15	16		V
	Sinking 100mA, Code 00		0.75	1	V
V_{COM} Output Reset and Power-Up Value ⁽¹⁾	OTP not programmed, Code 512		$V_S/2$		V
Nominal V_{BIAS} Output Impedance	No Load on V_{BIAS} , V_{COM}		250		k Ω
Program to Out Delay			5		μs
Output Accuracy	$1\text{V} < V_{COM} < 17.7$		20	50	mV
Load Regulation	$V_{OUT} = V_S/2$, $I_{OUT} = +50\text{mA}$ to -50mA Step		0.5	1.5	mV/mA
V_{COM} ⁽¹⁾					
Offset			± 5	± 25	mV
Offset Drift	-25°C to $+100^\circ\text{C}$		5		$\mu\text{V}/^\circ\text{C}$
Common-Mode Range			0.8 to 18		V
Common-Mode Rejection	$0.8\text{V} < V_{IN} < 17.9\text{V}$		85		dB
Slew Rate			5		V/ μs
V_{BIAS}	No Load on V_{BIAS}				
Integral Nonlinearity			0.1	2	LSB
Differential Nonlinearity			0.1	2	LSB
Gain Error			0.1	1	%FSC
Accuracy			20	50	mV
ANALOG POWER SUPPLY					
Operating Range ⁽²⁾	V_S	7		18	V
Total Analog Supply Current	I_S		0.9	1.5	mA
	Output at Reset Values, No Load			1.5	mA
DIGITAL					
Logic 1 Input Voltage	V_{IH}	$0.7 \times V_{SD}$			V
Logic 0 Input Voltage	V_{IL}			$0.3 \times V_{SD}$	V
Logic 0 Output Voltage	V_{OL}		0.15	0.4	V
Input Leakage		$I_{SINK} = 3\text{mA}$	± 0.01	± 10	μA
Clock Frequency	f_{CLK}	Standard/Fast Mode		400	kHz
		High-Speed Mode		3.4	MHz
DIGITAL POWER SUPPLY					
Operating Voltage Range	V_{SD}	2.0		5.5	V
Digital Supply Current ⁽²⁾	I_{SD}		25	50	μA
	over Temperature		100		μA
TEMPERATURE					
Specified Temperature Range		-40		$+85$	$^\circ\text{C}$
Operating Temperature Range		-40		$+95$	$^\circ\text{C}$
Storage Temperature Range		-65		$+150$	$^\circ\text{C}$
Thermal Resistance	θ_{JA}				
TSSOP-8			150		$^\circ\text{C}/\text{W}$
DFN-10			47		$^\circ\text{C}/\text{W}$

(1) BUF01900 only.

(2) Minimum analog supply voltage is 8.5V when programming OTP memory.

TYPICAL CHARACTERISTICS

At $T_A = +25^\circ\text{C}$, $V_S = 18\text{V}$, $V_{SD} = 5\text{V}$, $R_L = 1.5\text{k}\Omega$ connected to ground, and $C_L = 200\text{pF}$, unless otherwise noted.

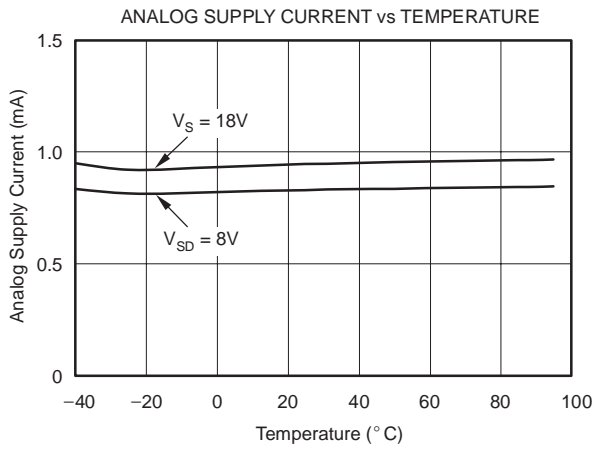

Figure 1

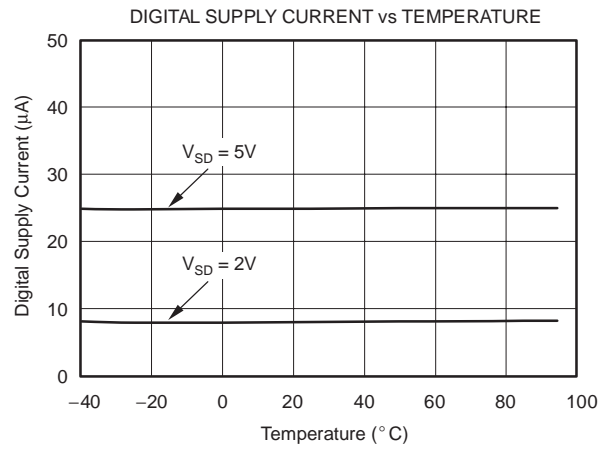

Figure 2

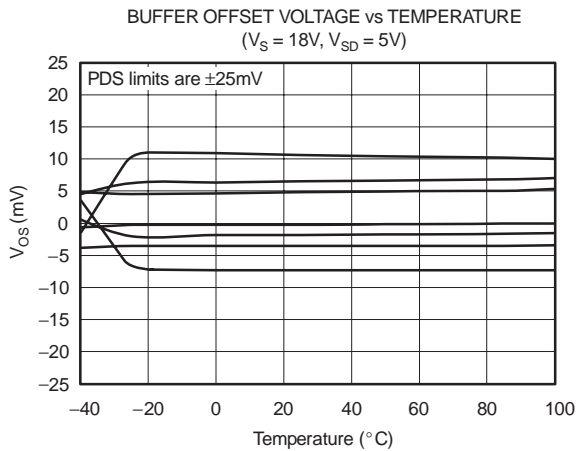

Figure 3

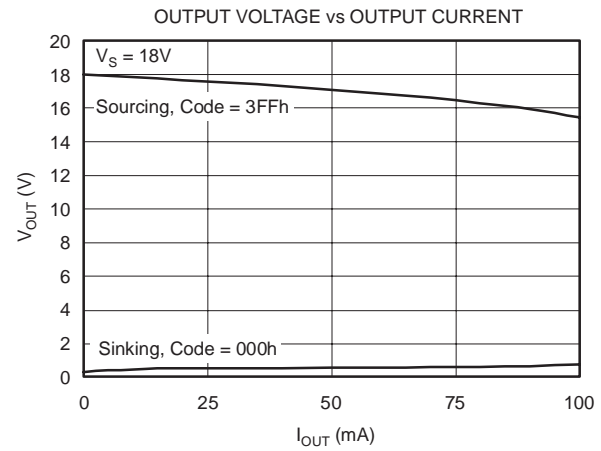

Figure 4

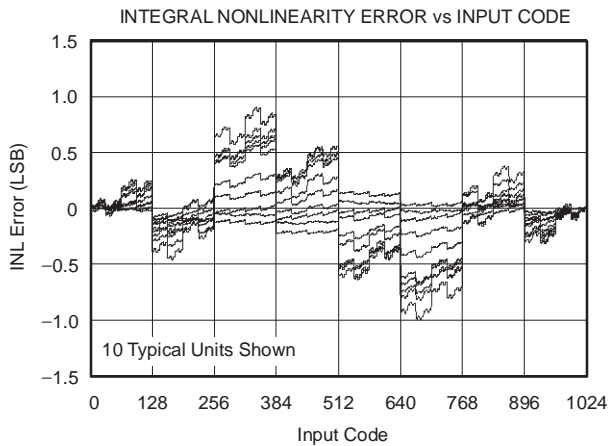

Figure 5

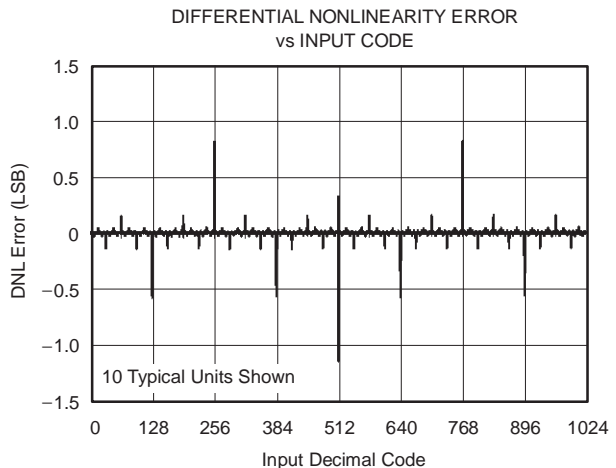

Figure 6

TYPICAL CHARACTERISTICS (cont)

At $T_A = +25^\circ\text{C}$, $V_S = 18\text{V}$, $V_{SD} = 5\text{V}$, $R_L = 1.5\text{k}\Omega$ connected to ground, and $C_L = 200\text{pF}$, unless otherwise noted.

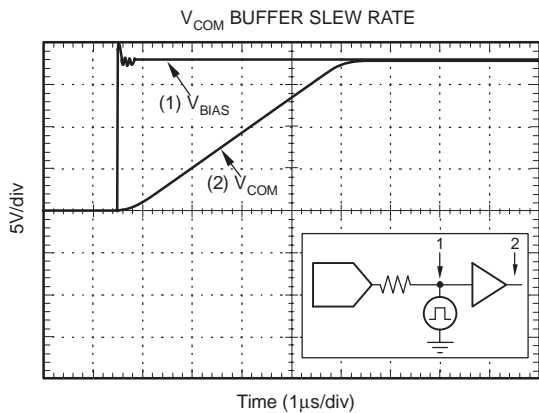

Figure 7

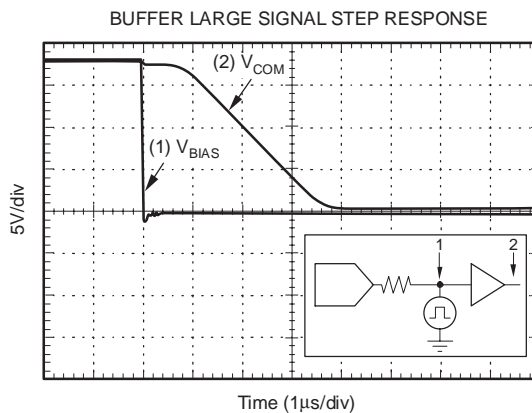

Figure 8

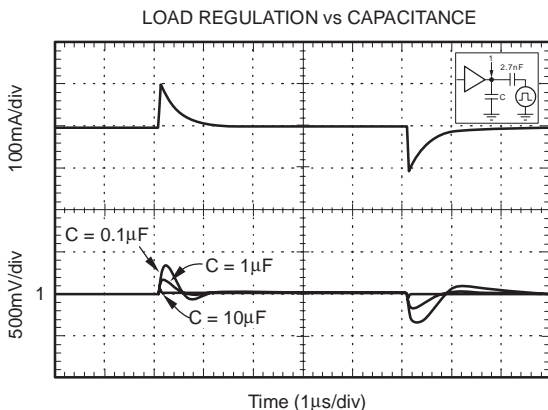

Figure 9

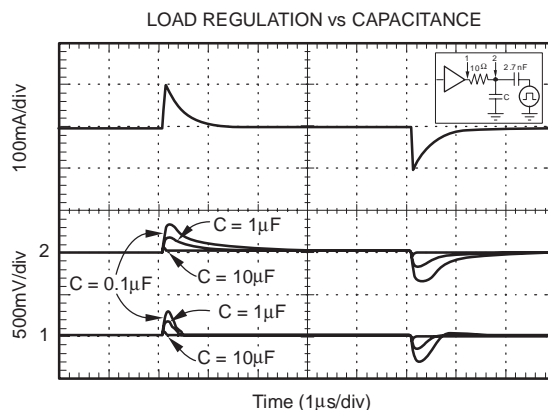

Figure 10

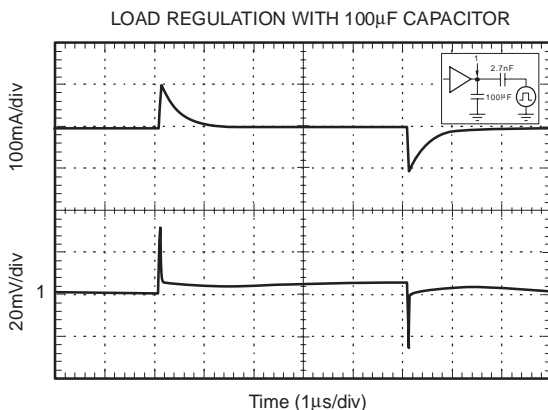

Figure 11

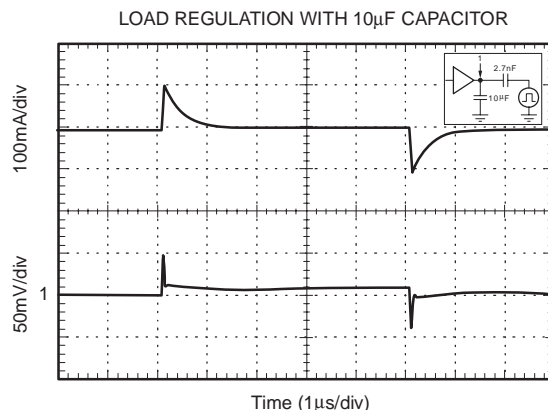

Figure 12

TYPICAL CHARACTERISTICS (cont)

At $T_A = +25^\circ\text{C}$, $V_S = 18\text{V}$, $V_{SD} = 5\text{V}$, $R_L = 1.5\text{k}\Omega$ connected to ground, and $C_L = 200\text{pF}$, unless otherwise noted.

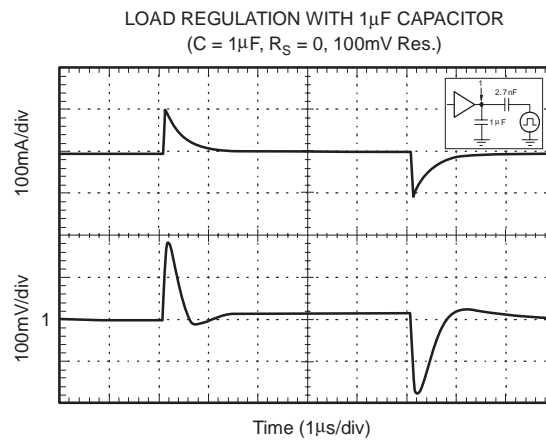

Figure 13

APPLICATIONS INFORMATION

OVERVIEW

The BUF0190x family of products consists of a 10-bit digital-to-analog converter (DAC) that is programmed through an industry-standard two-wire interface. It contains on-chip nonvolatile memory that stores a specific DAC value that is read at power-up. The BUF0190x family consists of two devices: The BUF01900 contains a voltage buffer that is capable of driving high-current; the BUF01901 is a lower-cost version without the buffer. The BUF0190x is especially well-suited for V_{COM} calibration in LCD panels; however, it can also be used in many other applications. Figure 14 shows the BUF01900 in a typical configuration.

BUF01900: ON-CHIP BUFFER

Unlike many programmable V_{COM} calibrators on the market, the BUF01900 offers an integrated V_{COM} buffer with high current output drive capability. The output is capable of delivering peak currents over 100mA to within 4V from the positive supply and to within 2V from the negative supply. Using this option is very cost-effective and convenient in systems that do not use multi-channel gamma buffers with integrated V_{COM} drive. Figure 15 shows the BUF01900 in a typical configuration.

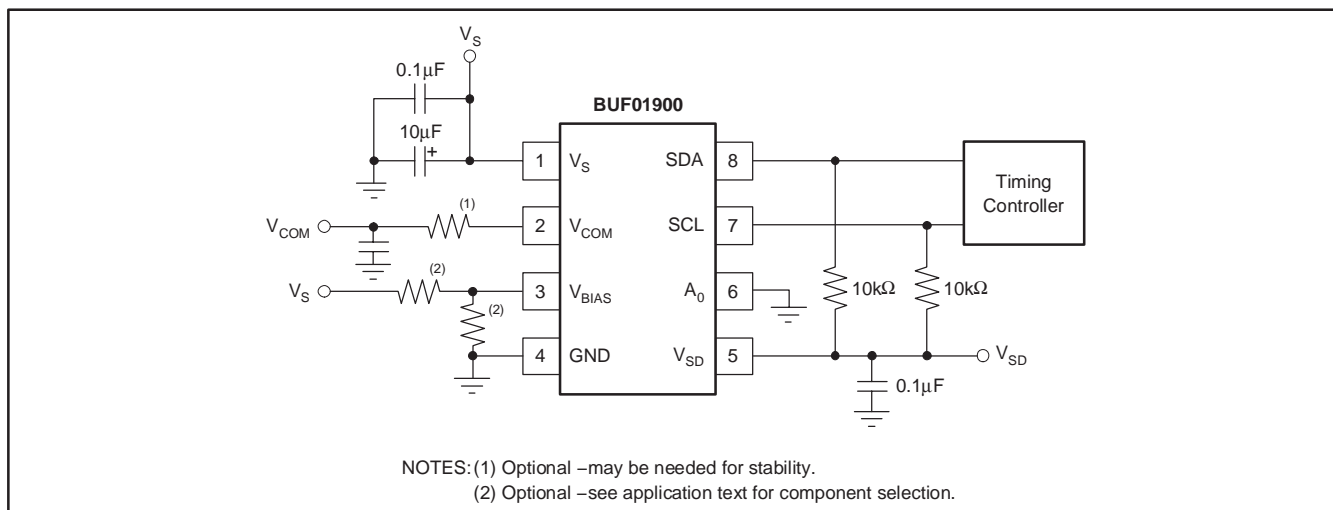

Figure 14. Typical Application Diagram

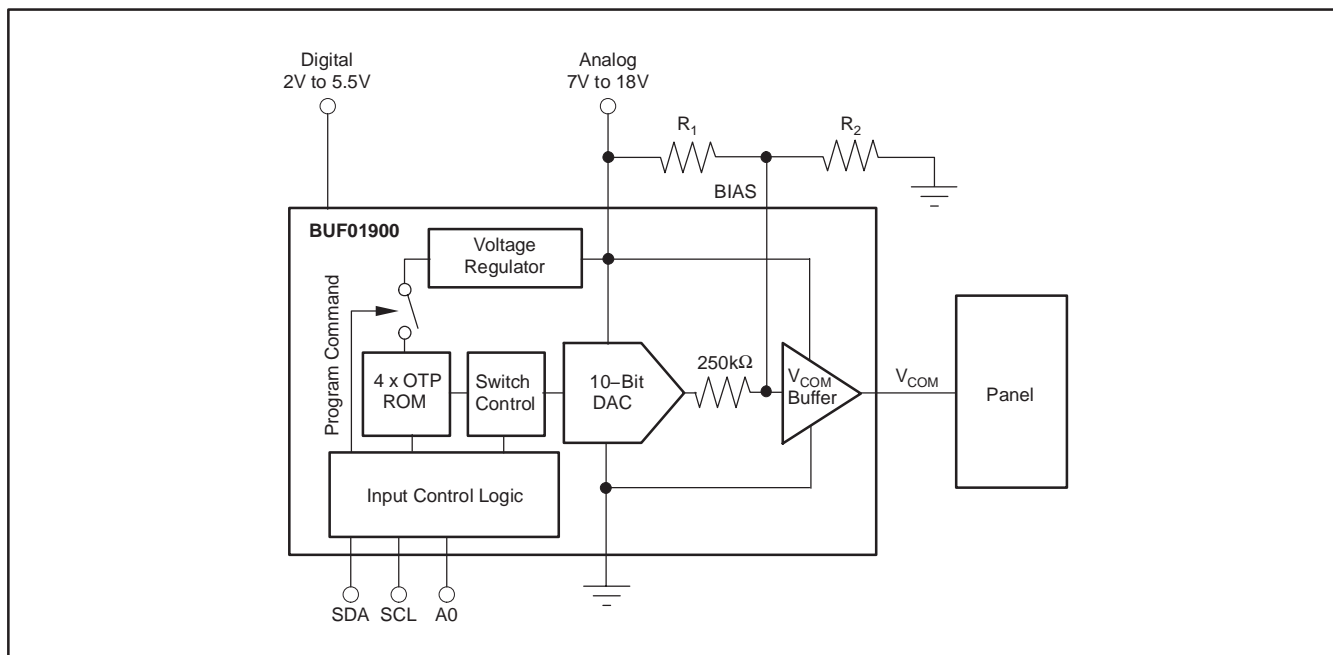

Figure 15. BUF01900 Typical Configuration

BUF01901: USING EXTERNAL V_{COM} BUFFER

Many LCD panel modules use gamma buffers, such as TI's BUFxx704, BUFxx703, BUF11702 and the new BUF11705, that already include an integrated V_{COM} driver. Some other LCD modules use more complicated compensation schemes that require an external high-speed V_{COM} op amp. BUF01901 is optimized for lowest cost and is intended to be used with an external V_{COM} buffer or op amp. Figure 16 illustrates a typical configuration of the BUF01901 with the BUF11705.

ON-CHIP NONVOLATILE MEMORY

The BUF0190x is optimized for the smallest die size available and consequently the lowest cost to support high vol-

ume production. The on-chip OTP (one-time-programmable) memory helps to achieve significant die size reduction over EEPROM memory technology. This reduction is partly because of the smaller area of the OTP memory cell, but also a result of the fact that an EEPROM requires a high programming voltage typically generated with an onboard charge pump. OTP memory technology does not require the higher programming voltage; consequently, no charge pump is needed, resulting in a smaller and lower-cost solution.

During production, the V_{COM} voltage is typically adjusted only once. However, to allow for programming errors and rework, the BUF0190x supports a total of four write cycles to the OTP memory. This capacity means that the previously programmed code in the OTP can be overwritten a total of three times.

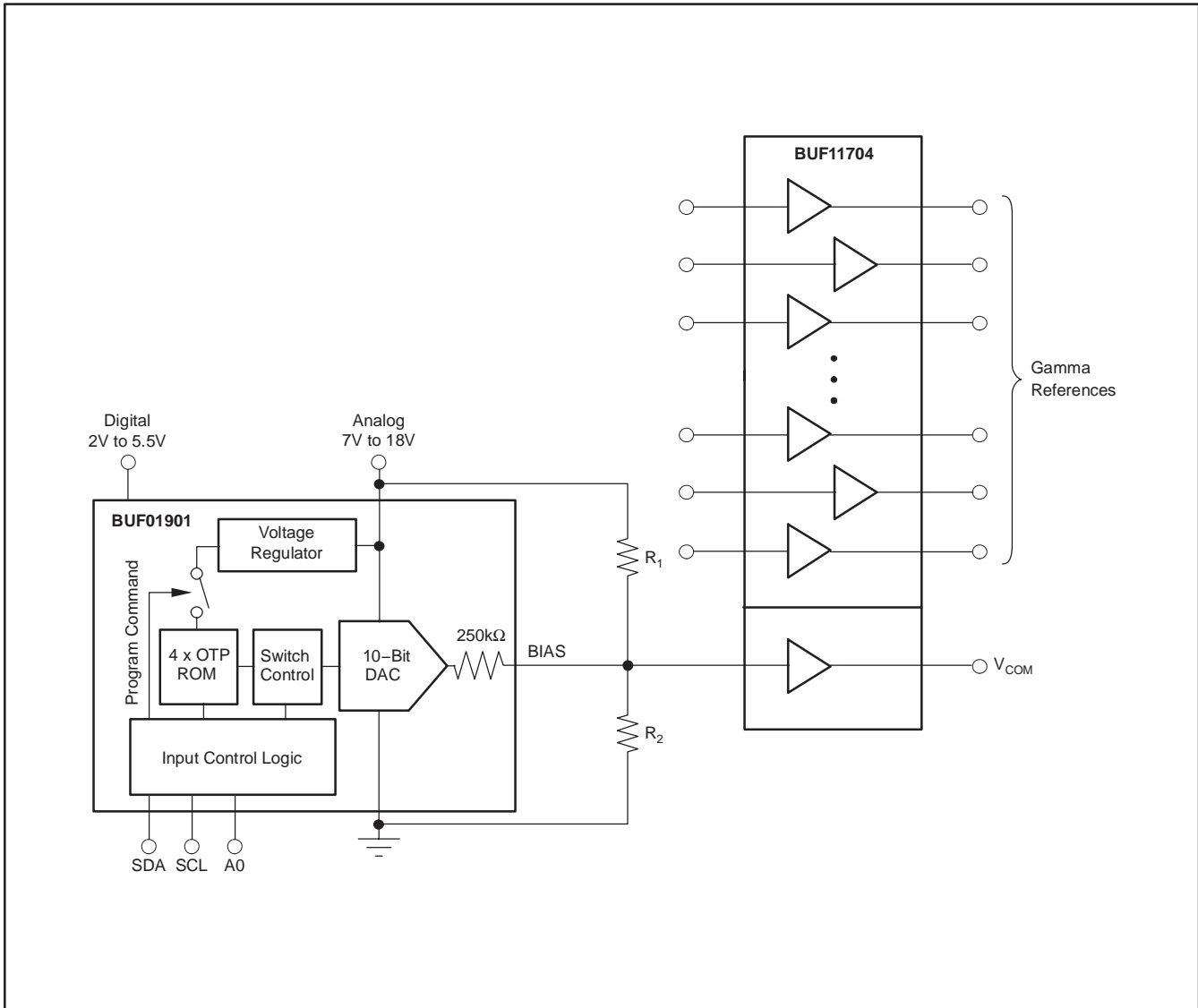

Figure 16. BUF01901 Typical Configuration

POWER-SUPPLY VOLTAGE

The BUF0190x can be powered using an analog supply voltage from 7V to 18V, and a digital supply from 2V to 5.5V. The digital supply must be applied prior to the analog supply to avoid excessive current and power consumption.

During programming of the OTP, the analog power supply must be at least 8.5V.

BUFFER INPUT AND OUTPUT RANGE

The integrated buffer has a single p-channel input stage. The input range includes the positive supply and extends down to typically 0.8V above the negative supply (GND). In a typical LCD application, this is normally sufficient because the nominal V_{COM} level is often close to $V_2/2$ and, therefore, fairly far away from either supply rail. In addition, the adjustment range is usually not much larger than 1V in either direction of the nominal V_{COM} voltage. In applications requiring a wider output swing, the output voltage to the buffer should be limited to approximately 0.8V above the negative power supply to keep the buffer input stage in its linear operating region. For lower input voltages, the output results might not be valid; however, they will also not lead to damage of the device.

The Rail-to-Rail output stage is designed to drive large peak currents greater than 100mA.

TWO-WIRE BUS OVERVIEW

The BUF0190x communicates through an industry-standard, two-wire interface to receive data in slave mode. This standard uses a two-wire, open-drain interface that supports multiple devices on a single bus. Bus lines are driven to a logic low level only. The device that initiates the communication is called a *master*, and the devices controlled by the master are *slaves*. The master generates the serial clock on the clock signal line (SCL), controls the bus access, and generates START and STOP conditions.

To address a specific device, the master initiates a START condition by pulling the data signal line (SDA) from a HIGH to LOW logic level while SCL is HIGH. All slaves on the bus shift in the slave address byte, with the last bit indicating whether a read or write operation is intended. During the ninth clock pulse, the slave being addressed responds to the master by generating an Acknowledge and pulling SDA LOW.

Data transfer is then initiated and eight bits of data are sent, followed by an Acknowledge bit. During data transfer, SDA must remain stable while SCL is HIGH. Any change in SDA while SCL is HIGH will be interpreted as a START or STOP condition.

Once all data has been transferred, the master generates a STOP condition, indicated by pulling SDA from LOW to HIGH while SCL is HIGH.

The BUF0190x can act only as a slave device; therefore, it never drives SCL. The SCL is only an input for the BUF0190x.

ADDRESSING THE BUF01900 AND BUF01901

The address of the BUF0190x in the TSSOP-8 package is 111011x, where x is the state of the A0 pin. When the A0 pin is LOW, the device acknowledges on address 76h. If the A0 pin is HIGH, the device acknowledges on address 77h. Table 1 summarizes device addresses.

Table 1. Quick-Reference Table of Addresses

DEVICE/COMPONENT	ADDRESS
TSSOP Package:	
A0 pin is LOW (device will acknowledge on address 76h)	1110110
A0 pin is HIGH (device will acknowledge on address 77h)	1110111
DFN Package:	
A0 pin is LOW, A1 is LOW (device will acknowledge on address 74h)	1110100
A0 pin is HIGH, A1 is LOW (device will acknowledge on address 75h)	1110101
A0 pin is LOW, A1 is HIGH (device will acknowledge on address 76h)	1110110
A0 pin is HIGH, A1 is HIGH (device will acknowledge on address 77h)	1110111

The address of the BUF0190x in the DFN-10 package is 11101yx, where x is the state of the A0 pin and y is the state of the A1 pin. When the A0 and A1 pins are both LOW, the device acknowledges on address 74h. If the A0 is HIGH and A1 is LOW, the device acknowledges on address 75h. When the A0 is LOW, and A1 is HIGH, the device acknowledges on address 76h. If the A0 and A1 pins are both HIGH, the device address is 77h.

Other addresses are possible through a simple mask change. Contact your TI representative for ordering information and availability.

DATA RATES

The two-wire bus operates in one of three speed modes:

- Standard: allows a clock frequency of up to 100kHz;
- Fast: allows a clock frequency of up to 400kHz; and
- High-speed mode (or Hs mode): allows a clock frequency of up to 3.4MHz.

The BUF0190x is fully compatible with all three modes. No special action is required to use the device in Standard or Fast modes, but High-speed mode must be activated. To activate High-speed mode, send a special address byte of 00001xxx, with $SCL \leq 400\text{kHz}$, following the START condition; xxx are bits unique to the Hs-capable master, which can be any value. This byte is called the *Hs master code*. (Note that this is different from normal address bytes—the low bit does not indicate read/write status.) The BUF0190x will respond to the High-speed command regardless of the value of these last three bits. The BUF0190x does not acknowledge this byte; the communication protocol prohibits acknowledgment of the Hs master code. On receiving a master code, the BUF0190x switches on its Hs mode filters, and communicates at up to 3.4MHz.

Additional high-speed transfers may be initiated without resending the Hs mode byte by generating a repeat START without a STOP. The BUF0190x switches out of Hs mode with the next STOP condition.

GENERAL CALL RESET AND POWER-UP

The BUF0190x responds to a General Call Reset, which is an address byte of 00h (0000 0000) followed by a data byte of 06h (0000 0110). The BUF0190x acknowledges both bytes. Upon receiving a General Call Reset, the BUF0190x performs a full internal reset, as though it had been powered off and then on. It always acknowledges the General Call address byte of 00h (0000 0000), but does not acknowledge any General Call data bytes other than 06h (0000 0110).

The BUF0190x automatically performs a reset upon power-up. As part of the reset, the BUF0190x is configured for the output to change to the programmed OTP memory value, or to mid-scale, '1000000000', if the OTP value has not been programmed. Table 2 provides a summary of command codes.

Table 2. Quick-Reference Table of Command Codes

COMMAND	CODE
General Call Reset	Address byte of 00h followed by a data byte of 06h.
High-Speed Mode	00001xxx, with $SCL \leq 400\text{kHz}$; where xxx are bits unique to the Hs-capable master. This byte is called the Hs master code.

READ/WRITE OPERATIONS:

Read commands are performed by setting the read/write bit HIGH. Setting the read/write bit LOW performs a write transaction.

Figure 17 and Figure 18 show the timing diagrams for read and write operations.

Writing:

To write to the DAC register:

1. Send a START condition on the bus.
2. Send the device address and read/write bit = LOW. The BUF01900/BUF01901 will acknowledge this byte.
3. Send two bytes of data for the DAC register. Begin by sending the most significant byte (bits D15—D8; only bits D9 and D8 are used, and D15—D13 must *not* be 010 or 001), followed by the least significant byte (bits D7—D0). The register is updated after receiving the second byte.
4. Send a STOP condition on the bus.

The BUF0190x acknowledges each data byte. If the master terminates communication early by sending a STOP or START condition on the bus, the DAC output will not update.

Reading:

To read the register of the DAC:

1. Send a START condition on the bus.
2. Send the device address and read/write bit = HIGH. The BUF0190x will acknowledge this byte.
3. Receive two bytes of data. The first received byte is the most significant byte (bits D15—D8; only bits D9 and D8 have meaning, and bits D15—D12 will show the programming status of the OTP memory). See Table 3. The next byte is the least significant byte (bits D7—D0).
4. Acknowledge after receiving the first byte only.
5. Do not acknowledge the second byte of data or send a STOP condition on the bus.

Communication may be terminated by the master by sending a premature STOP or START condition on the bus, or by not sending the Acknowledge.

Table 3. OTP Memory Status

CODE (Bits D15 – D12)	OTP PROGRAMMING STATUS
0000	OTP has not been programmed.
0001	OPT has been programmed once.
0011	OTP has programmed twice.
0111	OPT has programmed three times.
1111	OTP has programmed all four times.

ACQUIRE OF OTP MEMORY

An acquire command updates the DAC output to the value stored in OTP memory. If the OTP memory has not been programmed, the DAC output code is '0000000000'.

Figure 19 shows the timing diagram for the acquire command.

Acquire Command

1. Send a START condition on the bus.
2. Send the device address and read/write bit = LOW. The device will acknowledge this byte.
3. Send the acquire command. Bits D7—D5 must be set to 001. Bits D4—D0 do not have meaning. This byte will be acknowledged.
4. Send a STOP condition on the bus.

Writing OTP Memory

The BUF0190x is able to write to the OTP memory a maximum of four times. Writing to the OTP memory a fourth time uses all available memory and disables the ability to perform additional writes (see table 3). A reset or acquire command updates the DAC output to the most recently written OTP memory value.

When programming the OTP memory, the analog supply voltage must be between 8.5V and 18V.

Write commands are performed by setting the read/write bit LOW.

To write to OTP memory:

1. Send a START condition on the bus.
2. Send the device address and read/write bit = LOW. The BUF0190x acknowledges this byte.
3. Send two bytes of data for the OTP memory. Begin by sending the most significant byte first (bits D15—D8, of which only bits D9 and D8 are data bits, and bits D15—D13 must be 010), followed by the least significant byte (bits D7—D0). The register updates after receiving the second byte.
4. Send a STOP condition on the bus.

The BUF0190x acknowledges each data byte. If the master terminates communication early by sending a STOP or START condition on the bus, the specified OTP register will not be updated. Writing an OTP register updates the DAC output voltage.

Programming timing is taken from the two-wire bus. Therefore, the master must provide correct timing on the bus to ensure data is successfully written into OTP memory. Figure 20 shows the timing requirements for timing when the OTP write supply and OTP write signal are active.

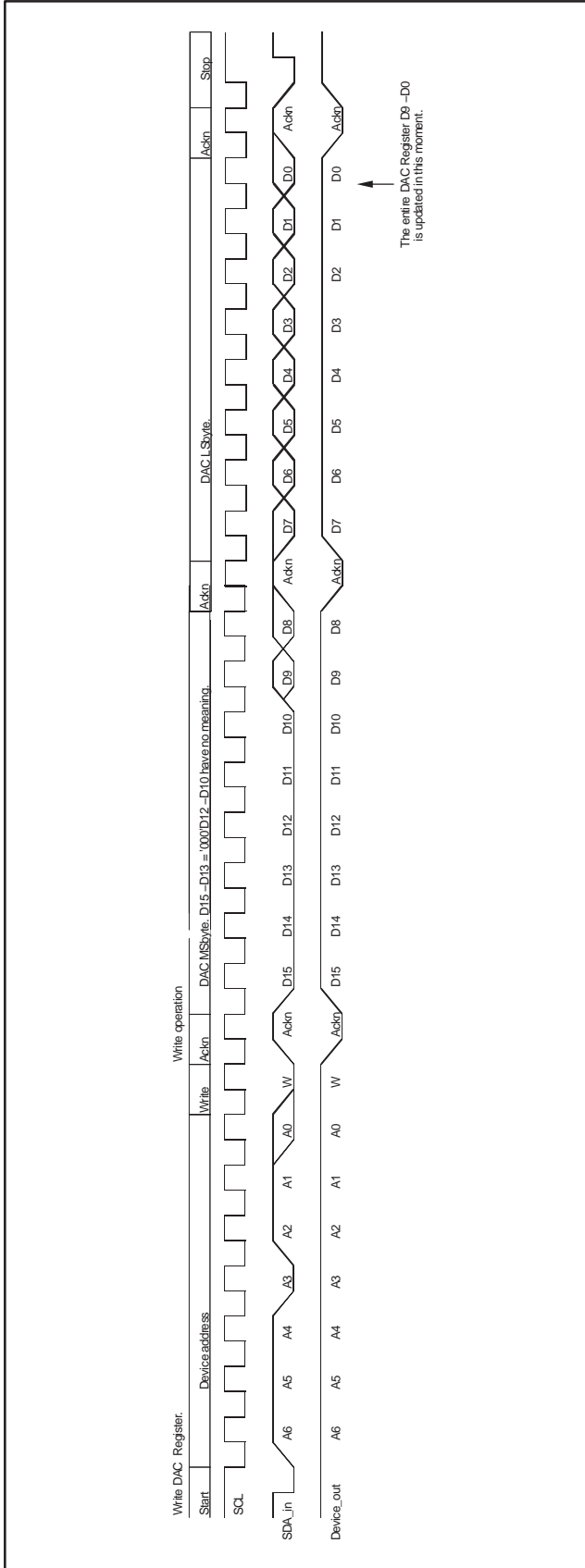

Figure 17. Timing Diagram for Write DAC Register

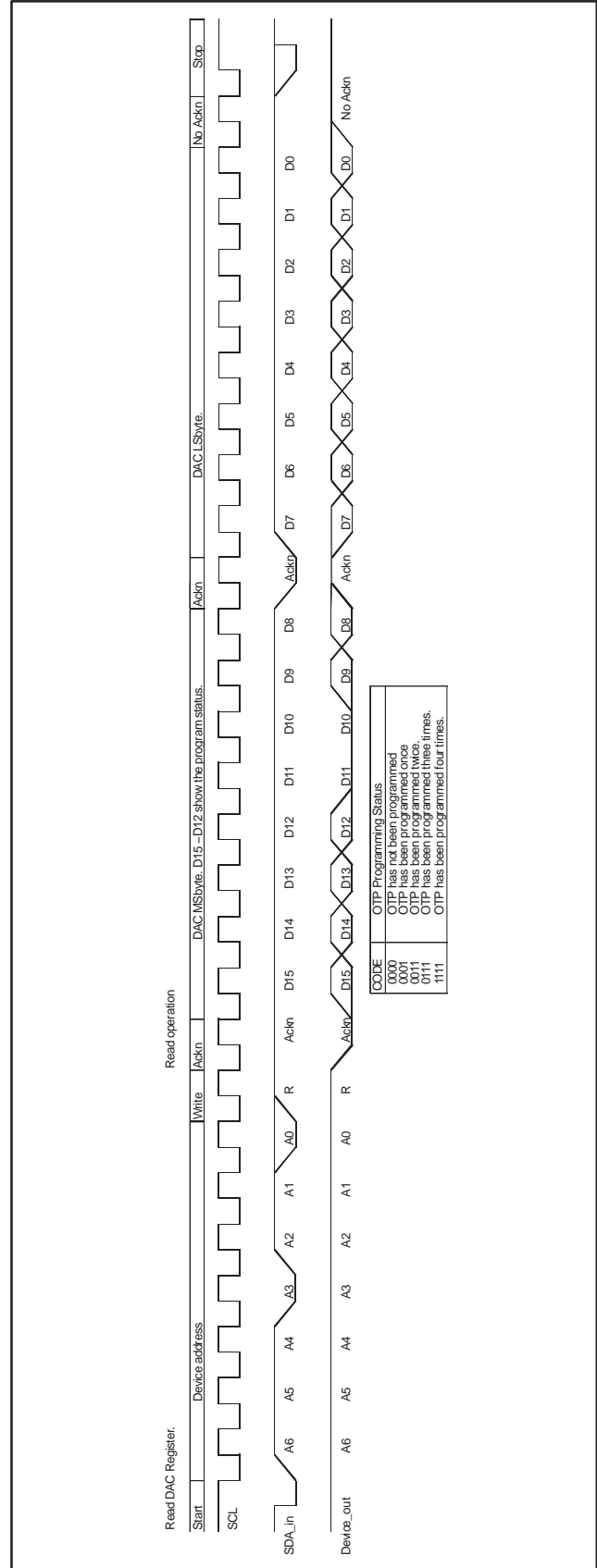

Figure 18. Timing Diagram for Read DAC Register

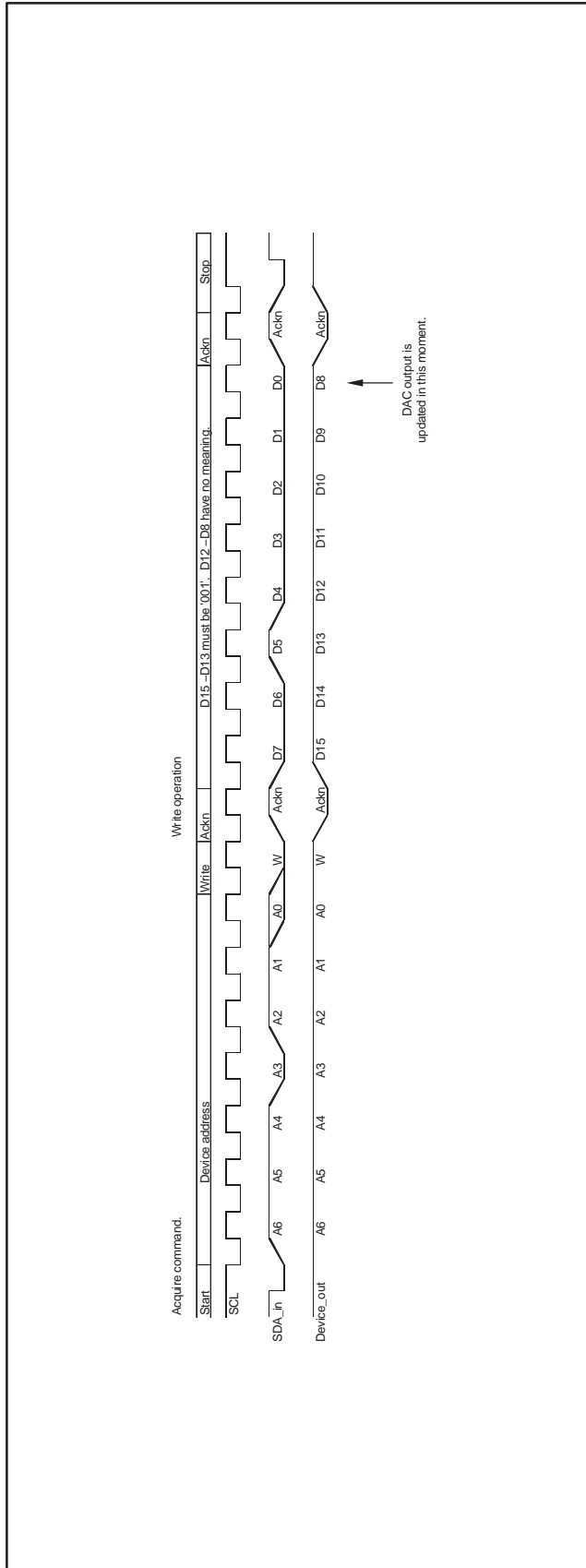

Figure 19. Timing Diagram for Acquire Command

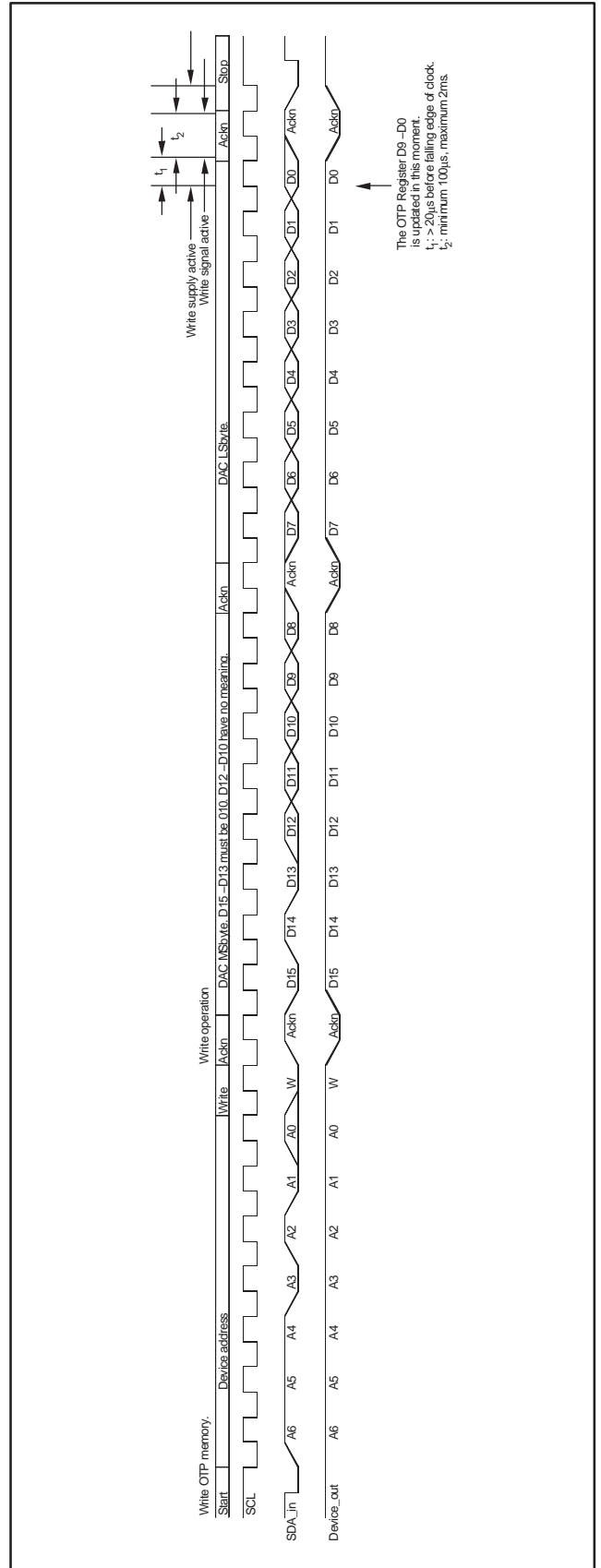

Figure 20. Timing Diagram for Write OTP Register

V_{COM} CALIBRATION

The BUF0190x provides a simple, time- and cost-efficient means to adjust the flicker performance of LCD panels either manually or automatically during the final stages of the LCD panel manufacturing process.

The 10-bit adjustment resolution of the BUF0190x exceeds the typical adjustment resolution of existing V_{COM} calibrators significantly. As with a traditional V_{COM} adjustment, which uses a mechanical potentiometer and a voltage divider for adjustment (see Figure 21), the BUF0190x uses an external voltage divider that is used to set the initial V_{COM} voltage as well as the adjustment range.

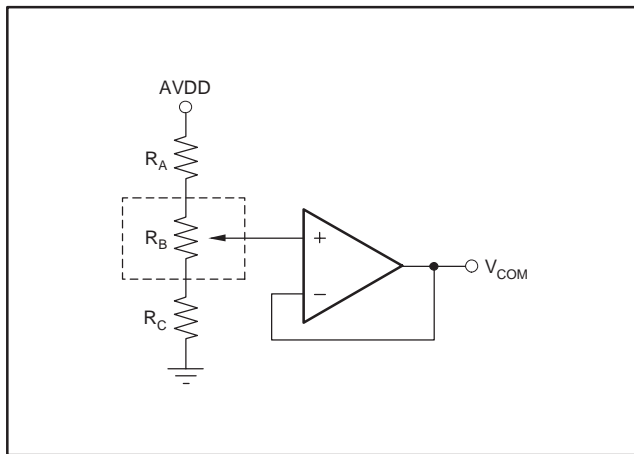

Figure 21. Traditional V_{COM} Adjustment

As Figure 22 shows, the 10-bit DAC acts as a Rail-to-Rail output voltage source with a nominal 250kΩ of output impedance. For example, at Code 000h, the lowest V_{COM} voltage is achieved since the 250kΩ impedance is now in parallel with R₂, which lowers the impedance of the lower side of the voltage divider. Consequently, code 3FFh results in the highest adjustable V_{COM} voltage.

Once the desired output level is obtained, the part can store the final setting using the non-volatile on-chip memory. See *Programming* section for detailed information.

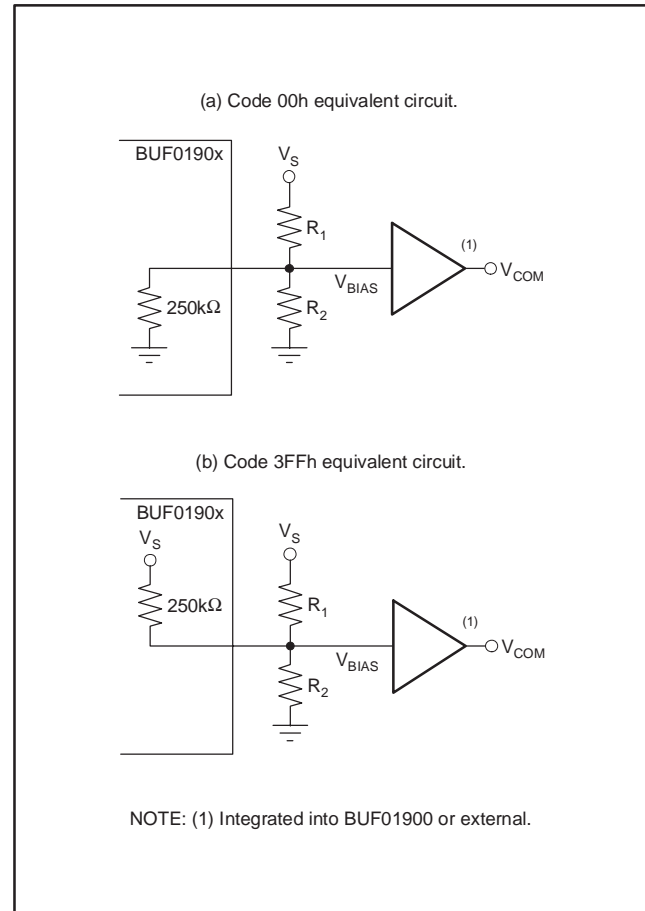

Figure 22. Simplified Block Diagram for V_{COM} Adjustment using BUF0190x

SELECTING THE ADJUSTMENT STEP SIZE

A maximum of 1024 adjustment steps can be realized with the BUF0190x, leading to very high adjustment resolution and very small step sizes. This flexibility can be advantageous during the panel development phase. In a practical production setting, however, this capability might lead to adjustment times that can be too long. A simple solution is to increase the step size between settings to more practical values for mass production. Limiting the number of adjustment steps between code 000h and code 3FFh to between 16 and 128 has been shown to typically yield acceptable adjustment results in the smallest amount of adjustment time.

EXTERNAL VOLTAGE DIVIDER RESISTOR SELECTION

The external resistive voltage-divider consisting of R_1 and R_2 (see Figure 16, Figure 17, and Figure 18) sets both the maximum value of the V_{COM} adjustment range and the initial V_{COM} voltage. Follow the steps below to calculate the correct values for R_1 and R_2

Step 1: Choose the supply voltage, (V_S)

Step 2: Set the nominal V_{COM} voltage. This voltage is the V_{COM} voltage at which the unadjusted panel should be at power-on. The default power-up DAC code is midscale.

Step 3: Choose the V_{COM} adjustment range. The adjustment range is the difference between the lowest and the highest desired V_{COM} voltage. If the default power-up code is not overwritten by software at the beginning of the adjustment cycle, the adjustment range is symmetrical around the chosen nominal V_{COM} voltage.

Step 4: Calculate the resistors based on the following formulas or simply download the Microsoft Excel™ calculator located in the product folder of BUF0190x available at www.ti.com.

$$R_1 = \frac{250k\Omega \cdot Adj_range}{V_{COM} - 0.5 \cdot (Adj_range)} \quad (1)$$

$$R_2 = \frac{1}{\frac{V_S}{V_{COM}} \left(\frac{1}{R_1} + \frac{1}{500k\Omega} \right) - \frac{1}{R_1} - \frac{1}{250k\Omega}} \quad (2)$$

CALCULATING THE V_{COM} OUTPUT VOLTAGE

With R_1 and R_2 properly set, V_{BIAS} or V_{COM} output voltage can be calculated for any digital code with the following formula:

$$V_{COM} = \frac{250k\Omega \cdot R_2 \cdot V_S + R_1 \cdot R_2 \cdot V_S (Code/1023)}{R_1 \cdot R_2 + 250k\Omega \cdot (R_1 + R_2)} \quad (3)$$

CALCULATING THE ADJUSTMENT RESOLUTION

The resolution of the adjustment is a function of the step size. The resolution can be calculated by simply dividing the chosen adjustment range by the number of steps:

Resolution = Adj_range/steps (example: 32 steps between code 0h and code 3FFh)

DESIGN EXAMPLE

Step 1: Supply Voltage is 10V.

Step 2: Nominal V_{COM} is determined to be 4V.

Step 3: The desired total adjustment range is 1V. In the case of using the default power-up DAC code (midscale), the adjustment range for the V_{COM} voltage will be from 3.5V to 4.5V.

Step 4: Calculation of R_1 and R_2

$R_1 = 71.4k\Omega \Rightarrow$ choose closest 1% resistor (71.5k Ω)

$R_2 = 45.5k\Omega \Rightarrow$ choose closest 1% resistor (45.3k Ω)

Step 5: Appropriate number of adjustment steps between code 00h and code 3FFh is determined to be 32. This value leads to a step size of 32 codes between adjustment points, which translates into approximately 31mV voltage difference between steps.

MOTOR DRIVE CIRCUIT

The BUF01900 can be used to drive small motors directly because of the large output drive capability (> 100mA), as illustrated in Figure 23.

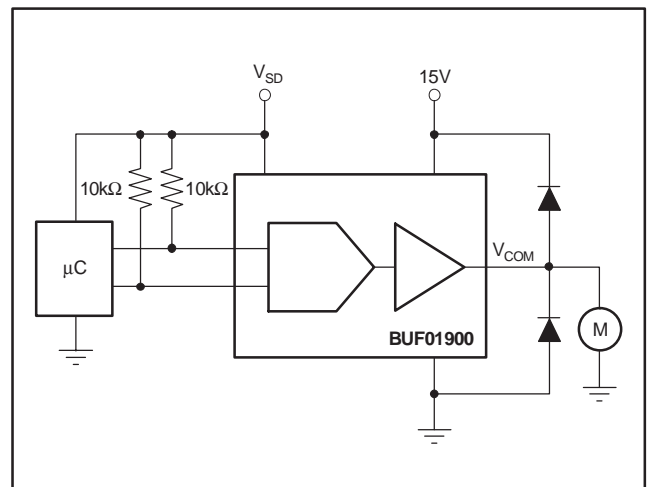

Figure 23. Motor Drive Circuit

PROGRAMMABLE POWER SUPPLY

The BUF0190x integrated buffer amplifier can drive large capacitive loads (see Typical Characteristics) and greater than 100mA of output current, making it well-suited for programmable power supplies.

Note that the BUF01900 integrated buffer has an input range that only extends to about 0.8V above GND; therefore, the programmable power supply is not able to output voltages less than approximately 0.8V.

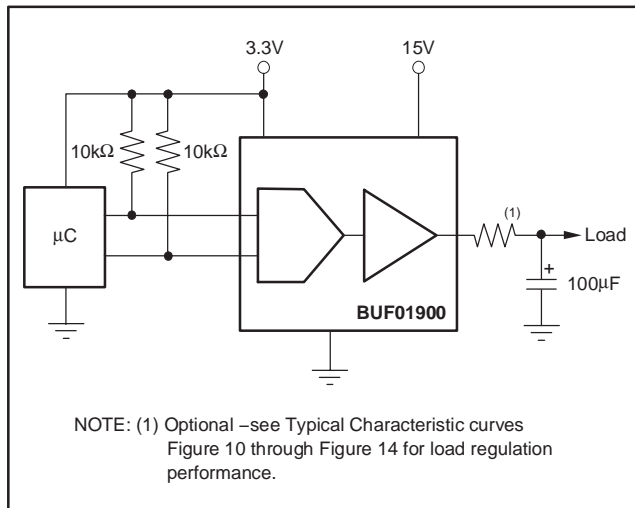

Figure 24. Programmable Power Supply

QFN/DFN THERMALLY-ENHANCED PACKAGE

The BUF0190x uses the 10-lead DFN package, a thin, thermally-enhanced package designed to eliminate the use of bulky heat sinks and slugs traditionally used in thermal packages. The DFN package can be easily mounted using standard printed circuit board (PCB) assembly techniques. See QFN/SON PCB Attachment Application Note (SLUA271) available at www.ti.com.

The thermal resistance junction to ambient ($R_{\theta JA}$) of the DFN package depends on the PCB layout. Using thermal vias and wide PCB traces improves thermal resistance. The thermal pad must be soldered to the PCB. The thermal pad on the bottom of the package should be connected to GND.

Soldering the exposed thermal pad significantly improves board-level reliability during temperature cycling, key push, package shear, and similar board-level tests. Even with applications that have low-power dissipation, the exposed pad must be soldered to the PCB to provide structural integrity and long-term reliability.

PACKAGING INFORMATION

Orderable Device	Status (1)	Package Type	Package Drawing	Pins	Package Qty	Eco Plan (2)	Lead/Ball Finish (6)	MSL Peak Temp (3)	Op Temp (°C)	Device Marking (4/5)	Samples
BUF01900AIDRCR	NRND	VSON	DRC	10	3000	Green (RoHS & no Sb/Br)	CU NIPDAU	Level-2-260C-1 YEAR		BOO	
BUF01900AIDRCT	NRND	VSON	DRC	10	250	Green (RoHS & no Sb/Br)	CU NIPDAU	Level-2-260C-1 YEAR		BOO	
BUF01900AIPW	NRND	TSSOP	PW	8	150	Green (RoHS & no Sb/Br)	CU NIPDAU	Level-2-260C-1 YEAR		F01900	
BUF01900AIPWR	NRND	TSSOP	PW	8	2000	Green (RoHS & no Sb/Br)	CU NIPDAU	Level-2-260C-1 YEAR		F01900	

(1) The marketing status values are defined as follows:

ACTIVE: Product device recommended for new designs.

LIFEBUY: TI has announced that the device will be discontinued, and a lifetime-buy period is in effect.

NRND: Not recommended for new designs. Device is in production to support existing customers, but TI does not recommend using this part in a new design.

PREVIEW: Device has been announced but is not in production. Samples may or may not be available.

OBSOLETE: TI has discontinued the production of the device.

(2) Eco Plan - The planned eco-friendly classification: Pb-Free (RoHS), Pb-Free (RoHS Exempt), or Green (RoHS & no Sb/Br) - please check <http://www.ti.com/productcontent> for the latest availability information and additional product content details.

TBD: The Pb-Free/Green conversion plan has not been defined.

Pb-Free (RoHS): TI's terms "Lead-Free" or "Pb-Free" mean semiconductor products that are compatible with the current RoHS requirements for all 6 substances, including the requirement that lead not exceed 0.1% by weight in homogeneous materials. Where designed to be soldered at high temperatures, TI Pb-Free products are suitable for use in specified lead-free processes.

Pb-Free (RoHS Exempt): This component has a RoHS exemption for either 1) lead-based flip-chip solder bumps used between the die and package, or 2) lead-based die adhesive used between the die and leadframe. The component is otherwise considered Pb-Free (RoHS compatible) as defined above.

Green (RoHS & no Sb/Br): TI defines "Green" to mean Pb-Free (RoHS compatible), and free of Bromine (Br) and Antimony (Sb) based flame retardants (Br or Sb do not exceed 0.1% by weight in homogeneous material)

(3) MSL, Peak Temp. - The Moisture Sensitivity Level rating according to the JEDEC industry standard classifications, and peak solder temperature.

(4) There may be additional marking, which relates to the logo, the lot trace code information, or the environmental category on the device.

(5) Multiple Device Markings will be inside parentheses. Only one Device Marking contained in parentheses and separated by a "~" will appear on a device. If a line is indented then it is a continuation of the previous line and the two combined represent the entire Device Marking for that device.

(6) Lead/Ball Finish - Orderable Devices may have multiple material finish options. Finish options are separated by a vertical ruled line. Lead/Ball Finish values may wrap to two lines if the finish value exceeds the maximum column width.

Important Information and Disclaimer: The information provided on this page represents TI's knowledge and belief as of the date that it is provided. TI bases its knowledge and belief on information provided by third parties, and makes no representation or warranty as to the accuracy of such information. Efforts are underway to better integrate information from third parties. TI has taken and continues to take reasonable steps to provide representative and accurate information but may not have conducted destructive testing or chemical analysis on incoming materials and chemicals. TI and TI suppliers consider certain information to be proprietary, and thus CAS numbers and other limited information may not be available for release.

In no event shall TI's liability arising out of such information exceed the total purchase price of the TI part(s) at issue in this document sold by TI to Customer on an annual basis.

TAPE AND REEL INFORMATION

QUADRANT ASSIGNMENTS FOR PIN 1 ORIENTATION IN TAPE

*All dimensions are nominal

Device	Package Type	Package Drawing	Pins	SPQ	Reel Diameter (mm)	Reel Width W1 (mm)	A0 (mm)	B0 (mm)	K0 (mm)	P1 (mm)	W (mm)	Pin1 Quadrant
BUF01900AIDRCR	VSON	DRC	10	3000	330.0	12.4	3.3	3.3	1.1	8.0	12.0	Q2
BUF01900AIDRCT	VSON	DRC	10	250	180.0	12.4	3.3	3.3	1.1	8.0	12.0	Q2
BUF01900AIPWR	TSSOP	PW	8	2000	330.0	12.4	7.0	3.6	1.6	8.0	12.0	Q1

TAPE AND REEL BOX DIMENSIONS

*All dimensions are nominal

Device	Package Type	Package Drawing	Pins	SPQ	Length (mm)	Width (mm)	Height (mm)
BUF01900AIDRCR	VSON	DRC	10	3000	367.0	367.0	35.0
BUF01900AIDRCT	VSON	DRC	10	250	210.0	185.0	35.0
BUF01900AIPWR	TSSOP	PW	8	2000	367.0	367.0	35.0

DRC (S-PVSON-N10)

PLASTIC SMALL OUTLINE NO-LEAD

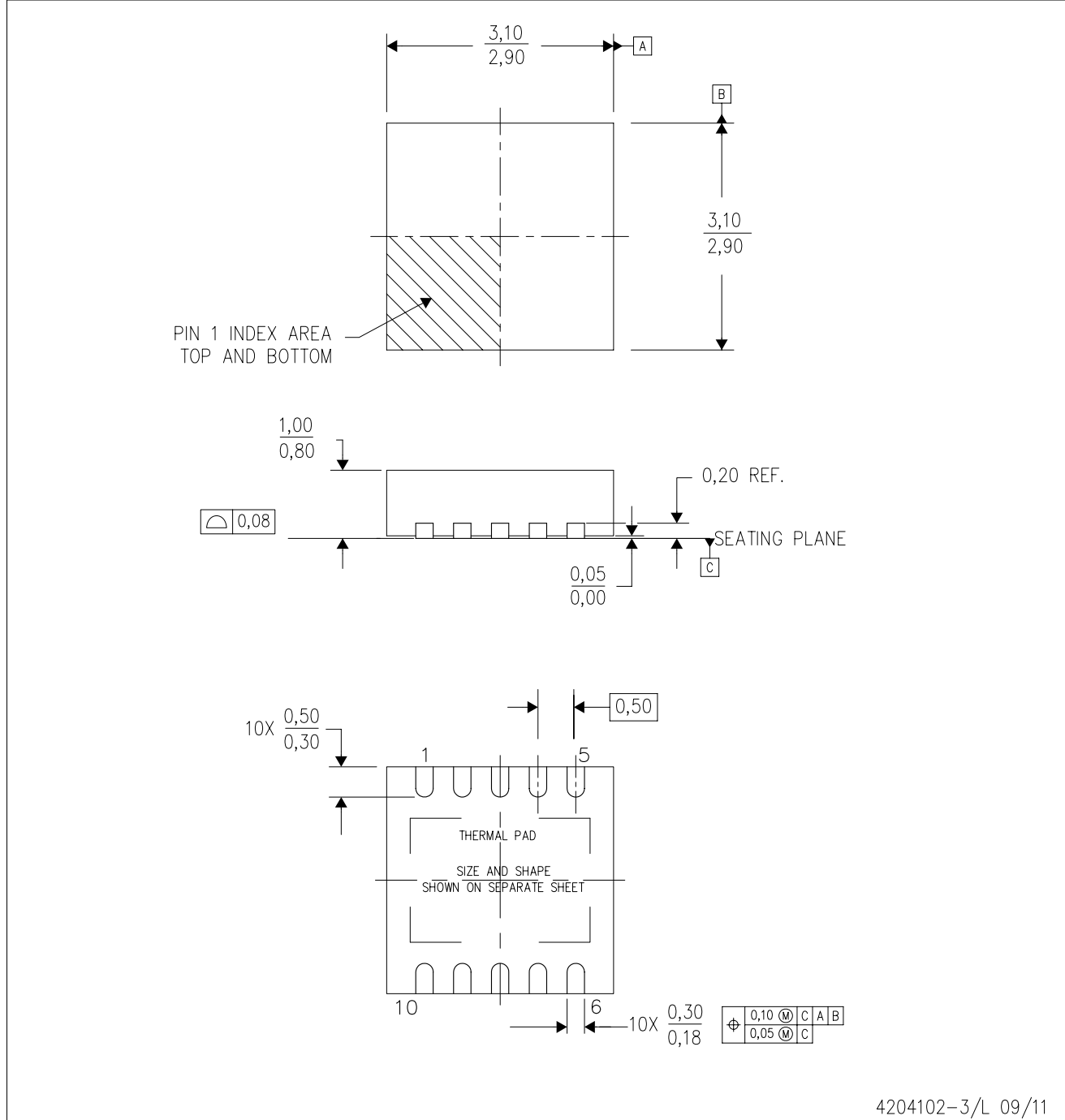

- NOTES:
- All linear dimensions are in millimeters. Dimensioning and tolerancing per ASME Y14.5M-1994.
 - This drawing is subject to change without notice.
 - Small Outline No-Lead (SON) package configuration.
 - The package thermal pad must be soldered to the board for thermal and mechanical performance, if present.
 - See the additional figure in the Product Data Sheet for details regarding the exposed thermal pad features and dimensions, if present

THERMAL PAD MECHANICAL DATA

DRC (S-PVSON-N10)

PLASTIC SMALL OUTLINE NO-LEAD

THERMAL INFORMATION

This package incorporates an exposed thermal pad that is designed to be attached directly to an external heatsink. The thermal pad must be soldered directly to the printed circuit board (PCB). After soldering, the PCB can be used as a heatsink. In addition, through the use of thermal vias, the thermal pad can be attached directly to the appropriate copper plane shown in the electrical schematic for the device, or alternatively, can be attached to a special heatsink structure designed into the PCB. This design optimizes the heat transfer from the integrated circuit (IC).

For information on the Quad Flatpack No-Lead (QFN) package and its advantages, refer to Application Report, QFN/SON PCB Attachment, Texas Instruments Literature No. SLUA271. This document is available at www.ti.com.

The exposed thermal pad dimensions for this package are shown in the following illustration.

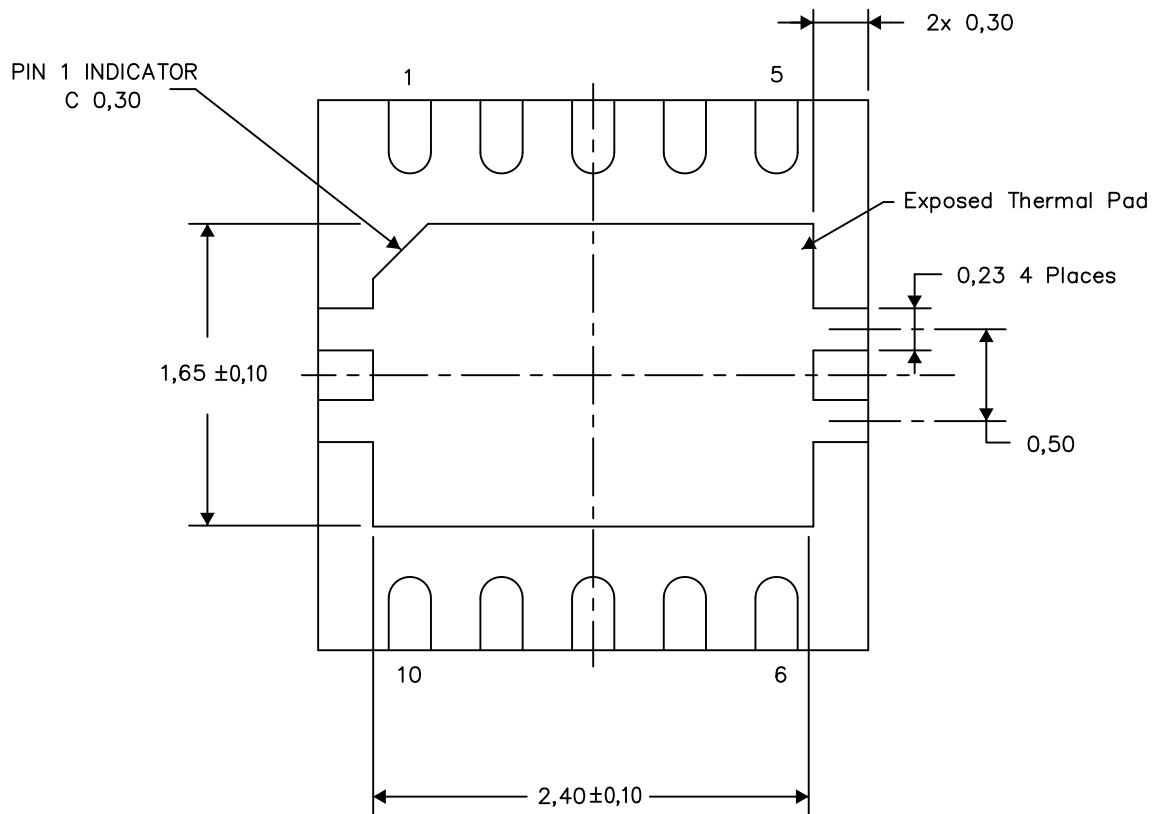

Bottom View

Exposed Thermal Pad Dimensions

4206565-3/Y 08/15

NOTE: A. All linear dimensions are in millimeters

LAND PATTERN DATA

DRC (S-PVSON-N10)

PLASTIC SMALL OUTLINE NO-LEAD

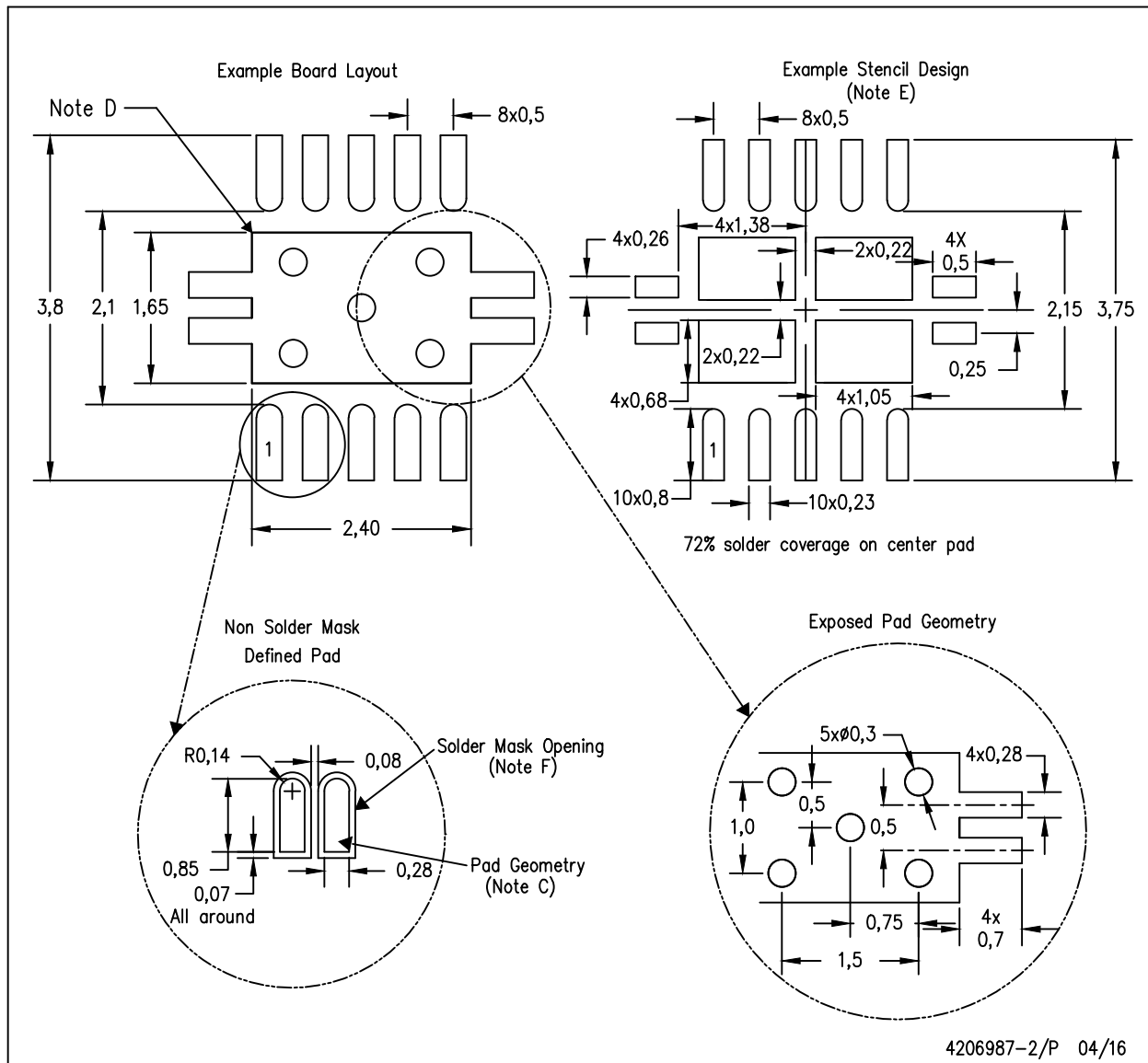

- NOTES:
- All linear dimensions are in millimeters.
 - This drawing is subject to change without notice.
 - Publication IPC-7351 is recommended for alternate designs.
 - This package is designed to be soldered to a thermal pad on the board. Refer to Application Note, Quad Flat-Pack Packages, Texas Instruments Literature No. SLUA271, and also the Product Data Sheets for specific thermal information, via requirements, and recommended board layout. These documents are available at www.ti.com <<http://www.ti.com>>.
 - Laser cutting apertures with trapezoidal walls and also rounding corners will offer better paste release. Customers should contact their board assembly site for stencil design recommendations. Refer to IPC 7525 for stencil design considerations.
 - Customers should contact their board fabrication site for minimum solder mask web tolerances between signal pads.

PW0008A



PACKAGE OUTLINE
TSSOP - 1.2 mm max height

SMALL OUTLINE PACKAGE

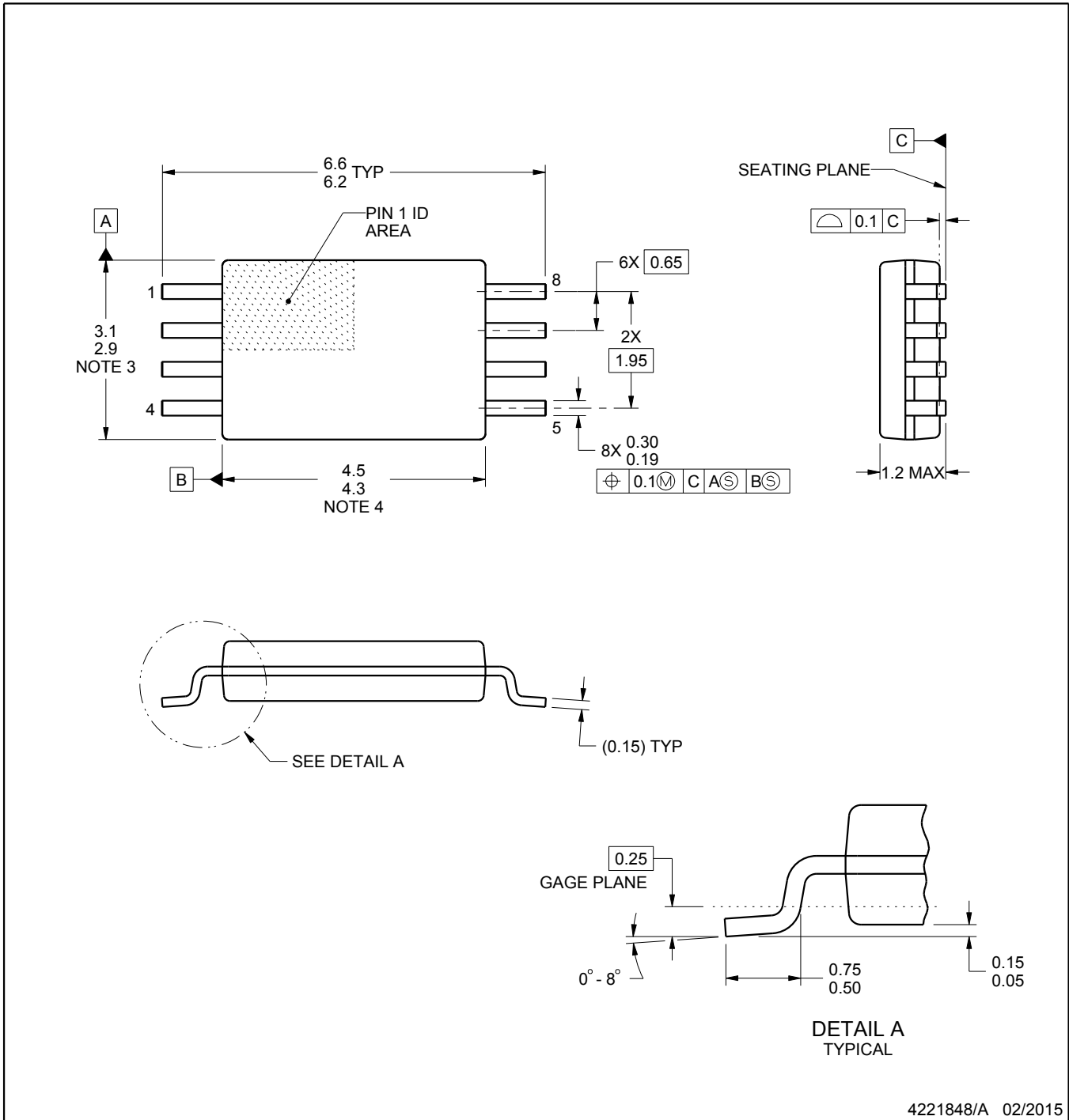

4221848/A 02/2015

NOTES:

1. All linear dimensions are in millimeters. Any dimensions in parenthesis are for reference only. Dimensioning and tolerancing per ASME Y14.5M.
2. This drawing is subject to change without notice.
3. This dimension does not include mold flash, protrusions, or gate burrs. Mold flash, protrusions, or gate burrs shall not exceed 0.15 mm per side.
4. This dimension does not include interlead flash. Interlead flash shall not exceed 0.25 mm per side.
5. Reference JEDEC registration MO-153, variation AA.

EXAMPLE BOARD LAYOUT

PW0008A

TSSOP - 1.2 mm max height

SMALL OUTLINE PACKAGE



LAND PATTERN EXAMPLE
SCALE:10X



SOLDER MASK DETAILS
NOT TO SCALE

4221848/A 02/2015

NOTES: (continued)

- 6. Publication IPC-7351 may have alternate designs.
- 7. Solder mask tolerances between and around signal pads can vary based on board fabrication site.

EXAMPLE STENCIL DESIGN

PW0008A

TSSOP - 1.2 mm max height

SMALL OUTLINE PACKAGE



SOLDER PASTE EXAMPLE
BASED ON 0.125 mm THICK STENCIL
SCALE:10X

4221848/A 02/2015

NOTES: (continued)

8. Laser cutting apertures with trapezoidal walls and rounded corners may offer better paste release. IPC-7525 may have alternate design recommendations.
9. Board assembly site may have different recommendations for stencil design.

IMPORTANT NOTICE

Texas Instruments Incorporated and its subsidiaries (TI) reserve the right to make corrections, enhancements, improvements and other changes to its semiconductor products and services per JESD46, latest issue, and to discontinue any product or service per JESD48, latest issue. Buyers should obtain the latest relevant information before placing orders and should verify that such information is current and complete. All semiconductor products (also referred to herein as "components") are sold subject to TI's terms and conditions of sale supplied at the time of order acknowledgment.

TI warrants performance of its components to the specifications applicable at the time of sale, in accordance with the warranty in TI's terms and conditions of sale of semiconductor products. Testing and other quality control techniques are used to the extent TI deems necessary to support this warranty. Except where mandated by applicable law, testing of all parameters of each component is not necessarily performed.

TI assumes no liability for applications assistance or the design of Buyers' products. Buyers are responsible for their products and applications using TI components. To minimize the risks associated with Buyers' products and applications, Buyers should provide adequate design and operating safeguards.

TI does not warrant or represent that any license, either express or implied, is granted under any patent right, copyright, mask work right, or other intellectual property right relating to any combination, machine, or process in which TI components or services are used. Information published by TI regarding third-party products or services does not constitute a license to use such products or services or a warranty or endorsement thereof. Use of such information may require a license from a third party under the patents or other intellectual property of the third party, or a license from TI under the patents or other intellectual property of TI.

Reproduction of significant portions of TI information in TI data books or data sheets is permissible only if reproduction is without alteration and is accompanied by all associated warranties, conditions, limitations, and notices. TI is not responsible or liable for such altered documentation. Information of third parties may be subject to additional restrictions.

Resale of TI components or services with statements different from or beyond the parameters stated by TI for that component or service voids all express and any implied warranties for the associated TI component or service and is an unfair and deceptive business practice. TI is not responsible or liable for any such statements.

Buyer acknowledges and agrees that it is solely responsible for compliance with all legal, regulatory and safety-related requirements concerning its products, and any use of TI components in its applications, notwithstanding any applications-related information or support that may be provided by TI. Buyer represents and agrees that it has all the necessary expertise to create and implement safeguards which anticipate dangerous consequences of failures, monitor failures and their consequences, lessen the likelihood of failures that might cause harm and take appropriate remedial actions. Buyer will fully indemnify TI and its representatives against any damages arising out of the use of any TI components in safety-critical applications.

In some cases, TI components may be promoted specifically to facilitate safety-related applications. With such components, TI's goal is to help enable customers to design and create their own end-product solutions that meet applicable functional safety standards and requirements. Nonetheless, such components are subject to these terms.

No TI components are authorized for use in FDA Class III (or similar life-critical medical equipment) unless authorized officers of the parties have executed a special agreement specifically governing such use.

Only those TI components which TI has specifically designated as military grade or "enhanced plastic" are designed and intended for use in military/aerospace applications or environments. Buyer acknowledges and agrees that any military or aerospace use of TI components which have **not** been so designated is solely at the Buyer's risk, and that Buyer is solely responsible for compliance with all legal and regulatory requirements in connection with such use.

TI has specifically designated certain components as meeting ISO/TS16949 requirements, mainly for automotive use. In any case of use of non-designated products, TI will not be responsible for any failure to meet ISO/TS16949.

Products

Audio	www.ti.com/audio
Amplifiers	amplifier.ti.com
Data Converters	dataconverter.ti.com
DLP® Products	www.dlp.com
DSP	dsp.ti.com
Clocks and Timers	www.ti.com/clocks
Interface	interface.ti.com
Logic	logic.ti.com
Power Mgmt	power.ti.com
Microcontrollers	microcontroller.ti.com
RFID	www.ti-rfid.com
OMAP Applications Processors	www.ti.com/omap
Wireless Connectivity	www.ti.com/wirelessconnectivity

Applications

Automotive and Transportation	www.ti.com/automotive
Communications and Telecom	www.ti.com/communications
Computers and Peripherals	www.ti.com/computers
Consumer Electronics	www.ti.com/consumer-apps
Energy and Lighting	www.ti.com/energy
Industrial	www.ti.com/industrial
Medical	www.ti.com/medical
Security	www.ti.com/security
Space, Avionics and Defense	www.ti.com/space-avionics-defense
Video and Imaging	www.ti.com/video

TI E2E Community

e2e.ti.com

Looking for pricing, stock, or lifecycle information?

Click below to explore more details on WIN SOURCE:

 [View BUF01901AIDRCR on WIN SOURCE](#)

 [Texas Instruments](#) Information

Optimize Your Supply Chain with WIN SOURCE Solutions

-  Global Sourcing Solution
-  Obsolete Management
-  Cost Control Management
-  Shortage Management
-  Alternative Solution
-  Excess Inventory Management