

Standard LCD Segment Driver

BU9799KV MAX 200 segments (SEG50×COM4)

● **Features**

- Integrated RAM for display data (DDRAM): 50 x 4 bit (Max 200 Segment)
- LCD drive output : 4 Common output, 50 Segment output
- Integrated Buffer AMP for LCD driving
- Integrated Oscillator circuit
- No external components
- Low power consumption design
- Independent power supply for LCD driving
- Integrated Electrical volume register (EVR) function

● **Applications**

- Telephone
- FAX
- Portable equipment (POS, ECR, PDA etc.)
- DSC
- DVC
- Car audio
- Home electrical appliances
- Meter equipment, etc.

● **Key Specifications**

- Supply Voltage Range: +2.5V to +5.5V
- LCD drive power supply Range: +2.5V to +5.5V
- Operating Temperature Range: -40°C to +85°C
- Max Segments: 200 Segments
- Display Duty: 1/4
- Bias: 1/2, 1/3 selectable
- Interface: 2wire serial interface

● **Package**

W (Typ.) x D (Typ.) x H (Max.)

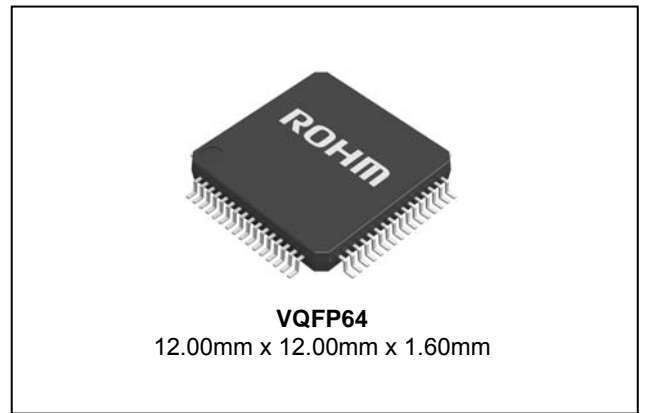

● **Typical Application Circuit**

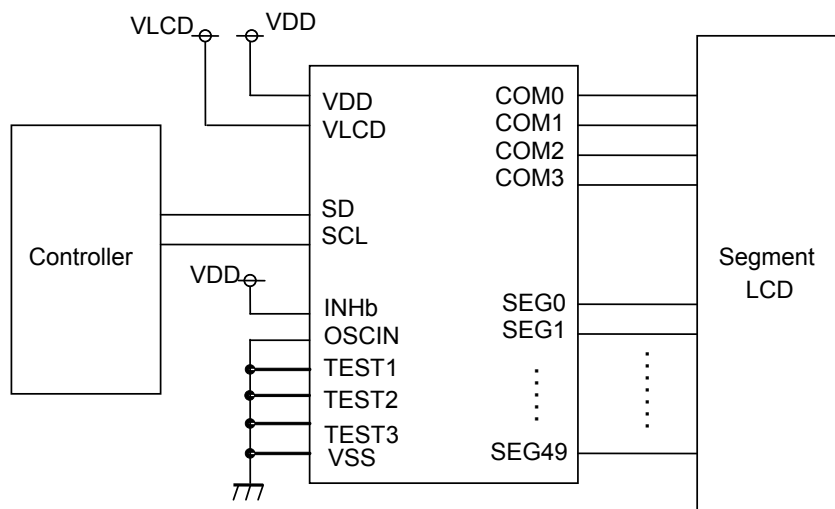

Internal oscillator circuit mode

Figure 1. Typical application circuit

●Block Diagram / Pin Configuration / Pin Description

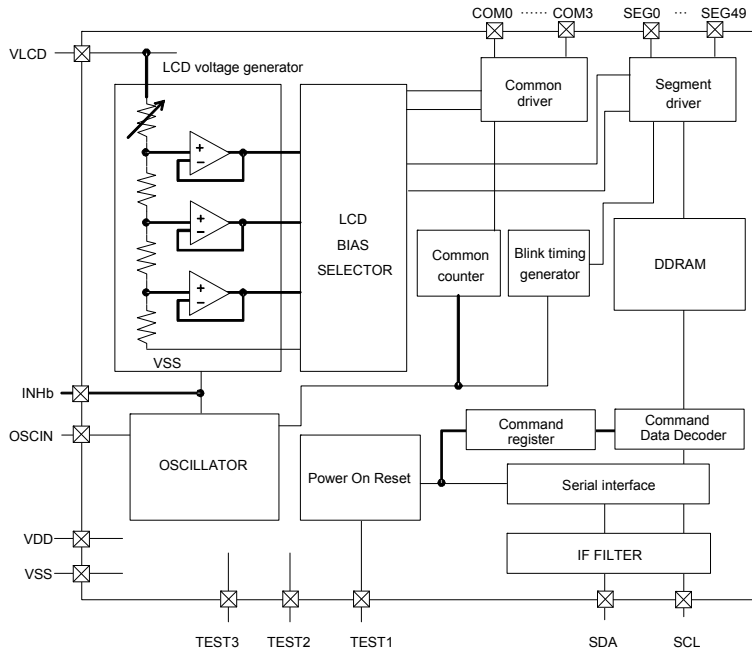

Figure 2. Block Diagram

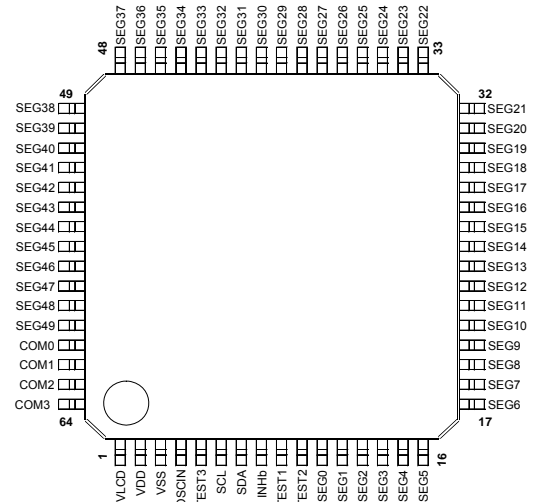

Figure 3. Pin Configuration (TOP VIEW)

Table 1 Pin Description

Terminal	Terminal No.	I/O	Function
INHb	8	I	Input terminal for turning off display H: turn on display L: turn off display
TEST1	9	I	Test input (ROHM use only) TEST1="L": POR circuit enable TEST1="H": POR circuit disable, refer to "Cautions in Power ON/OFF"
TEST2	10	I	Test input (ROHM use only) Must be connected to VSS
TEST3	5	I	Test input (ROHM use only) Must be connected to VSS
OSCIN	4	I	External clock input External clock and Internal clock modes can be selected by command. Must be connected to VSS when use internal oscillation circuit.
SDA	7	I	Serial data input
SCL	6	I	Serial data transfer clock
VSS	3		GND
VDD	2		Power supply
VLCD	1		Power supply for LCD driving
SEG0-49	11-60	O	SEGMENT output for LCD driving
COM0-3	61-64	O	COMMON output for LCD driving

● Absolute Maximum Ratings (VSS=0V)

Parameter	Symbol	Ratings	Unit	Remarks
Power Supply Voltage1	VDD	-0.5 to +7.0	V	Power supply
Power Supply Voltage2	VLCD	-0.5 to +7.0	V	LCD drive voltage
Power dissipation	Pd	0.75	W	When operated at more than 25°C, subtract 7.5mW/°C (Package only)
Input voltage range	VIN	-0.5 to VDD+0.5	V	
Operational temperature range	Topr	-40 to +85	°C	
Storage temperature range	Tstg	-55 to +125	°C	

● Recommended Operating Ratings(Ta=-40°C to +85°C,VSS=0V)

Parameter	Symbol	Ratings			Unit	Remarks
		MIN	TYP	MAX		
Power Supply Voltage1	VDD	2.5	-	5.5	V	Power supply
Power Supply Voltage2	VLCD	2.5	-	5.5	V	LCD drive voltage

● Electrical Characteristics

DC Characteristics (VDD=2.5V to 5.5V, VLCD=2.5V to 5.5V, VSS=0V, Ta=-40°C to 85°C, unless otherwise specified)

Parameter	Symbol	Limits			Unit	Conditions
		MIN	TYP	MAX		
"H" level input voltage	VIH	0.8VDD	-	VDD	V	SDA,SCL
"L" level input voltage	VIL	VSS	-	0.2VDD	V	SDA,SCL
"H" level input current	IIH	-	-	1	μA	SDA,SCL
"L" level input current	IIL	-1	-	-	μA	SDA,SCL
LCD Driver on resistance	SEG	RON	-	3.5	-	kΩ Iload=±10μA
	COM	RON	-	3.5	-	
Standby current	Ist	-	-	5	μA	Display off, Oscillation off
Power consumption 1	IDD	-	2.5	15	μA	VDD=3.3V, VLCD=5V, Ta=25°C Power save mode1, FR=70Hz 1/3 bias, Frame inverse
Power consumption 2	ILCD	-	10	20	μA	VDD=3.3V, VLCD=5V, Ta=25°C Power save mode1, FR=70Hz 1/3 bias, Frame inverse

Oscillation Characteristics (VDD=2.5V to 5.5V, VLCD=2.5V to 5.5V, VSS=0V, Ta=-40°C to 85°C, unless otherwise specified)

Parameter	Symbol	Limits			Unit	Conditions
		MIN	TYP	MAX		
Frame frequency	fCLK	56	80	104	Hz	FR = 80Hz setting, VDD=3.3V

MPU interface Characteristics

(VDD=2.5V to 5.5V, VLCD=2.5V to 5.5V, VSS=0V, Ta=-40°C to 85°C, unless otherwise specified)

Parameter	Symbol	Limits			Unit	Conditions
		MIN	TYP	MAX		
Input rise time	tr	-	-	0.3	μs	
Input fall time	tf	-	-	0.3	μs	
SCL cycle time	tSCYC	2.5	-	-	μs	
"H" SCL pulse width	tSHW	0.6	-	-	μs	
"L" SCL pulse width	tSLW	1.3	-	-	μs	
SDA setup time	tSDS	100	-	-	μs	
SDA hold time	tSDH	100	-	-	us	
Buss free time	tBUF	1.3	-	-	μs	
START condition hold time	tHD;STA	0.6	-	-	μs	
START condition setup time	tSU;STA	0.6	-	-	μs	
STOP condition setup time	tSU;STO	0.6	-	-	μs	

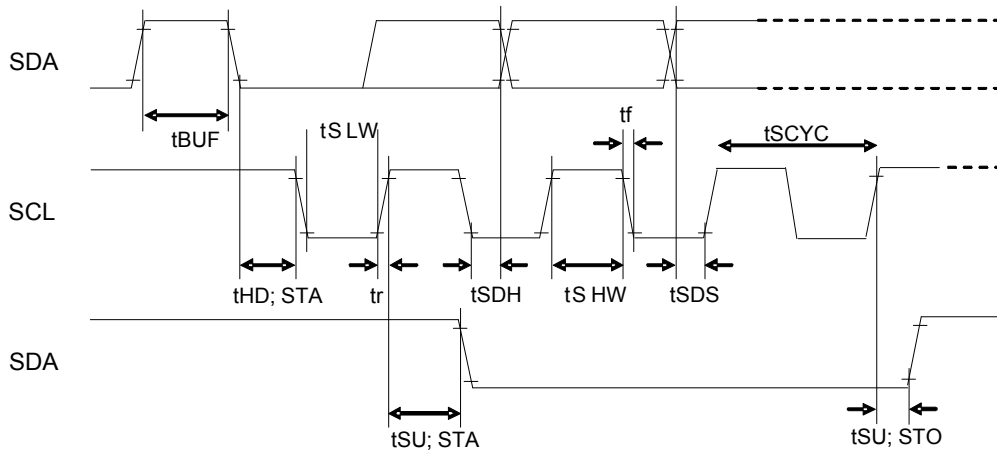

Figure 4. Interface Timing

● I/O equivalent circuit

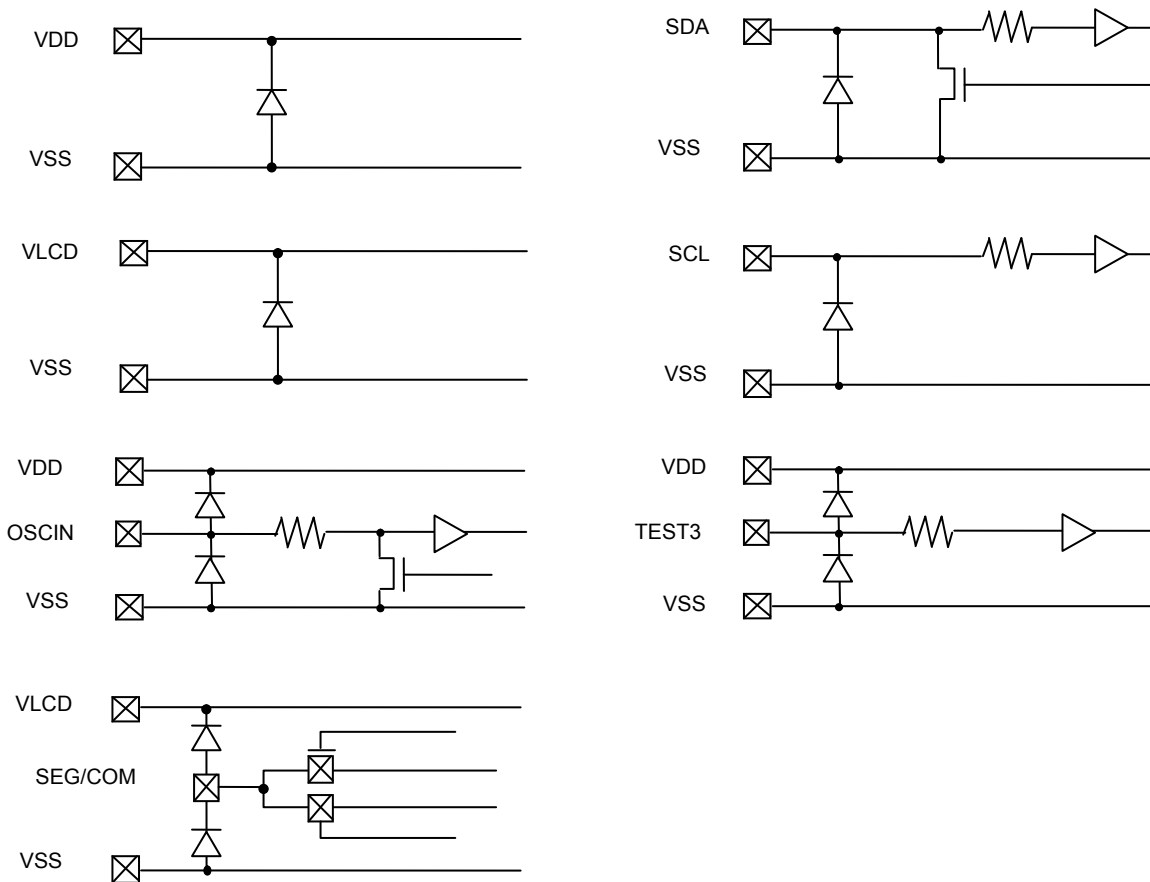
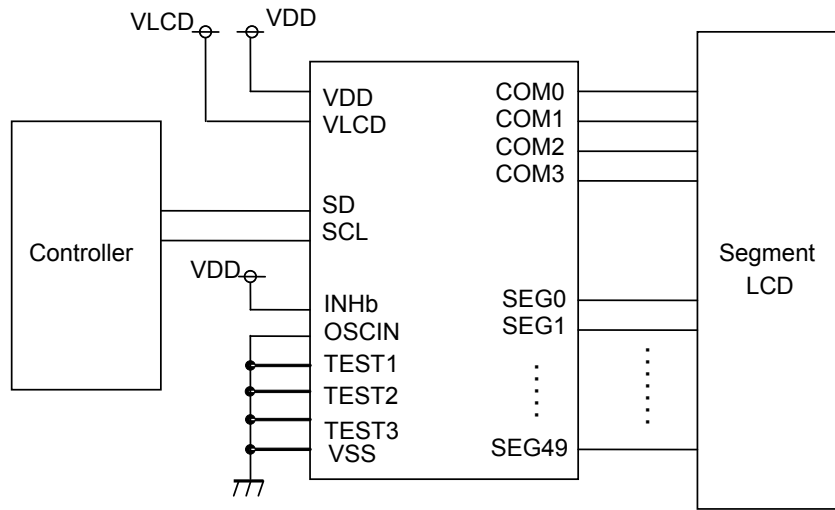
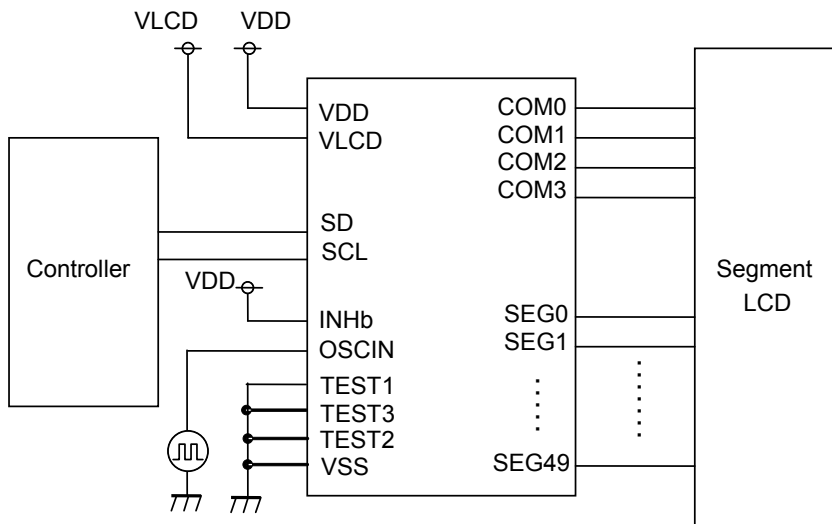

Figure 5. I/O equivalent circuit

● Example of recommended circuit



Internal oscillator circuit mode



External clock input mode

Figure 6. Example of recommended circuit

●Functional descriptions

○Command /Data transfer method

This device is controlled by 2-wire signal (SDA, SCL).

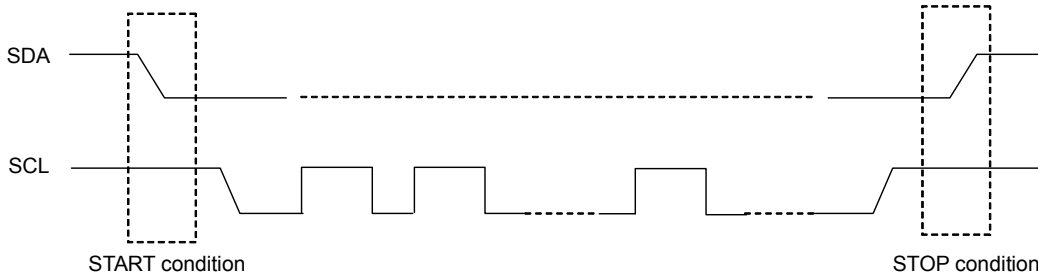

Figure 7. 2-SPI Command/Data transfer Format

It is necessary to generate START condition and STOP condition in 2wire serial interface transfer method.

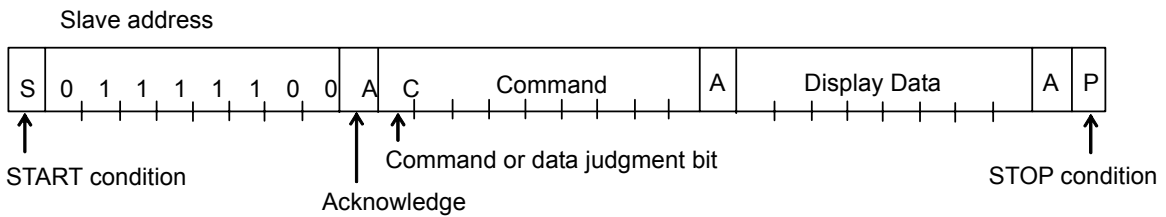

Figure 8. Interface protocol

Method of how to transfer command and data is shown as follows.

- 1) Generate "START condition".
- 2) Issue Slave address.
- 3) Transfer command and display data.

○Acknowledge

Data format is 8bits. After transfer of 8-bits data, Acknowledge bit is returned.

When SCL 8th = 'L' after transfer 8bit data (Slave Address, Command, Display Data), SDA outputs 'L'

When SCL 9th = 'L', SDA stops output function.

(Since SDA Output format is NMOS-Open-Drain, it can't output 'H' level.)

If there is no need Acknowledge function, please input 'L' level from SCL 8th='L' to SCL 9th='L'.

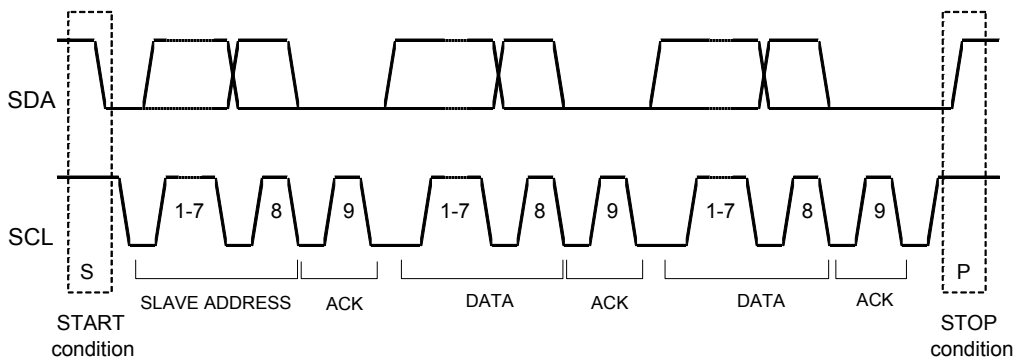
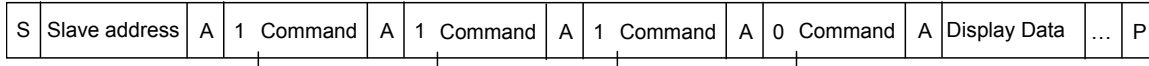

Figure 9. Acknowledge timing

○Command transfer method

Issue Slave Address (“01111100”) after generation of “START condition”.
 1byte after Slave Address always becomes command input.
 MSB (“command or data judge bit”) of command decide if next data is command or display data.
 When set “command or data judge bit”=‘1’, next byte data is command.
 When set “command or data judge bit”=‘0’, next byte data is display data.



When display data is transferred, inputting of command is not allowed
 When one wants to input command again, please generate “START condition” once.
 If “START condition” or “STOP condition” are inputted in the middle of command transmission, command will be canceled.
 If Slave address is inputted after “START condition”, execution of command is allowed.
 Please input “Slave Address” in the first data transmission after “START condition”.
 When Slave Address cannot be recognized in the first data transmission, Acknowledge does not return and next transmission will be invalid. When data transmission is invalid status, if “START conditions” are transmitted again, it will return to valid status.

Take care to observe MPU Interface characteristic such as Input rise time and Setup/Hold time when transferring command and data (Refer to MPU Interface).

○Write display and transfer method

This device has Display Data RAM (DDRAM) of 50×4=200bits.
 The relationship between data input and display data, DDRAM data and address are as follows;

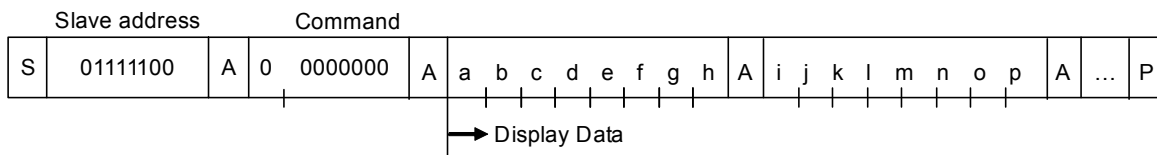

8 bit data will be stored in DDRAM. The address to be written is the address specified by ADSET command, and the address is automatically incremented in every 4bit data.
 Data can be continuously written in DDRAM by transmitting Data continuously.
 (When RAM data is written successively after writing RAM data to 31h (SEG49), the address is returned to 00h (SEG0) by the auto-increment function.

		DDRAM address												
		00	01	02	03	04	05	06	07	...	2Fh	30h	31h	
BIT	0	a	e	i	m									COM0
	1	b	f	j	n									COM1
	2	c	g	k	o									COM2
	3	d	h	l	p									COM3
		SEG0	SEG1	SEG2	SEG3	SEG4	SEG5	SEG6	SEG7		SEG47	SEG48	SEG49	

Data transfer to DDRAM happens every 4bit data.
 So it will be finished to transfer with no need to wait ACK.

OSCILLATOR

There are two kinds of clock for logic and analog circuit; from internal oscillator circuit or external clock input. If internal oscillator circuit will be used, OSCIN must be connected to VSS.

*When using external clock mode, it has to input external clock from OSCIN terminal after ICSET command setting.

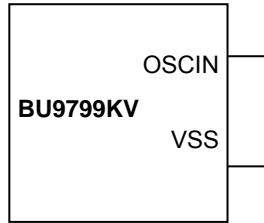

Figure 10. Internal oscillator circuit mode

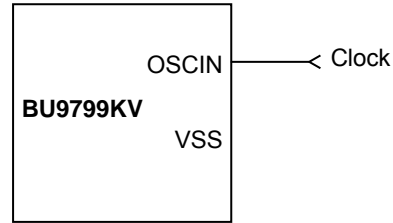

Figure 11. External clock input mode

○ LCD Driver Bias Circuit

This device generates LCD driving voltage with on-chip Buffer AMP.

And it can drive LCD at low power consumption.

*1/3 and 1/2Bias can set in MODESET command.

*Line and frame inversion can set in DISCTL command.

Refer to the "LCD driving waveform" about each LCD driving waveform.

○ Blink timing generator

This device has Blink function.

* This device will be at Blink mode with BLKCTL command.

Blink frequency varies widely by characteristic of fCLK, when internal oscillator circuit is used.

Refer to Oscillation Characteristics for more details on fCLK.

○ Reset initialize condition

Initial conditions after execution of Software Reset are as follows.

- Display is OFF.
- DDRAM address is initialized (DDRAM Data is not initialized).

Refer to Command Description about initialize value of register.

●Command / Function List

Description List of Command / Function

No.	Command	Function
1	Mode Set (MODE SET)	Set LCD drive mode
2	Address set (ADSET)	Set LCD display mode 1
3	Display control (DISCTL)	Set LCD display mode 2
4	Set IC Operation (ICSET)	Set IC operation
5	Blink control (BLKCTL)	Set Blink mode
6	All Pixel control (APCTL)	Set pixel condition
7	EVR Set 1 (EVRSET1)	Set EVR 1
8	EVR Set 2 (EVRSET2)	Set EVR 2

●Detailed command description

D7 (MSB) is bit for command or data judgment.
Refer to Command and data transfer method.

C: 0: Next byte is RAM write data.
1: Next byte is command.

OMode Set (MODE SET)

MSB				LSB			
D7	D6	D5	D4	D3	D2	D1	D0
C	1	0	0	P3	P2	*	*

(* : Don't care)

Set display ON and OFF

Setting	P3	Reset initialize condition
Display OFF	0	○
Display ON	1	

Display OFF : Regardless of DDRAM data, all SEGMENT and COMMON output will be stopped after 1frame off data write. Display OFF mode will be finished by Display ON.

Display ON : SEGMENT and COMMON output will be active and start to read the display data from DDRAM.

Set bias level

setup	P2	Reset initialize condition
1/3 Bias	0	○
1/2 Bias	1	

Refer to LCD driving waveform

OAddress set (ADSET)

MSB				LSB			
D7	D6	D5	D4	D3	D2	D1	D0
C	0	0	P4	P3	P2	P1	P0

It is set address as follows;

	MSB			LSB	
Internal register	Address [5]	Address [4]	· · ·	Address [0]	
command	ICSET [P2]	ADSET [P4]	· · ·	ADSET [P0]	

The range of address can be set as 00000 to 10001(2).

Don't set out of range address, otherwise address will be set 00000.

ICSET command is only define MSB bit of address, not set the address of DDRAM.

If want to set the address of DDRAM, it has to be input ADSET command.

ODisplay control (DISCTL)

MSB				LSB			
D7	D6	D5	D4	D3	D2	D1	D0
C	0	1	P4	P3	P2	P1	P0

Set Power save mode FR

Power save mode FR	P4	P3	Reset initialize condition
Normal mode (80Hz)	0	0	○
Power save mode1 (71Hz)	0	1	
Power save mode2 (64Hz)	1	0	
Power save mode3 (50Hz)	1	1	

* Power consumption is reduced in the follow order:
Normal mode > Power save mode1 > Power save mode2 > Power save mode3

Set LCD drive waveform

Setup	P2	Reset initialize condition
Line inversion	0	○
Frame inversion	1	

* Power consumption is reduced in the follow order: Line inversion > Frame inversion
Refer to LCD drive waveform

Set Power save mode SR

Setup	P1	P0	Reset initialize condition
Power save mode1	0	0	
Power save mode2	0	1	
Normal mode	1	0	○
High power mode	1	1	

* Power consumption is increased in the follow order:
Power save mode 1 < Power save mode 2 < Normal mode < High power mode

(Reference current consumption data)

Setup	Current consumption
Power save mode 1	×0.6
Power save mode 2	×0.8
Normal mode	×1.0
High power mode	×1.2

*Above data is reference. It depends on Panel load.

(Note) The setting of Power save mode FR, LCD waveform, Power save mode will influence the following display image qualities.
Please select most suitable value from current consumption and display image quality with LCD panel.

Mode	Flicker	Image quality, contrast
Power save mode FR	○	-
LCD waveform	○	○
Power save mode SR	-	○

○Set IC Operation (ICSET)

MSB							LSB
D7	D6	D5	D4	D3	D2	D1	D0
C	1	1	0	1	P2	P1	P0

P2: Define the MSB bit of address of DDRAM. Refer to ADSET command.

Set software reset execution

Setup	P1
No operation	0
Software Reset execute	1

This command will be set initialize condition.

When executed Software reset, P1 and P0 will be ignored.

Set oscillator mode

setup	P0	Reset initialize condition
Internal oscillation	0	○
External clock input	1	

Internal oscillation: Must be connected to VSS.

External clock input: Input external clock from OSCIN terminal

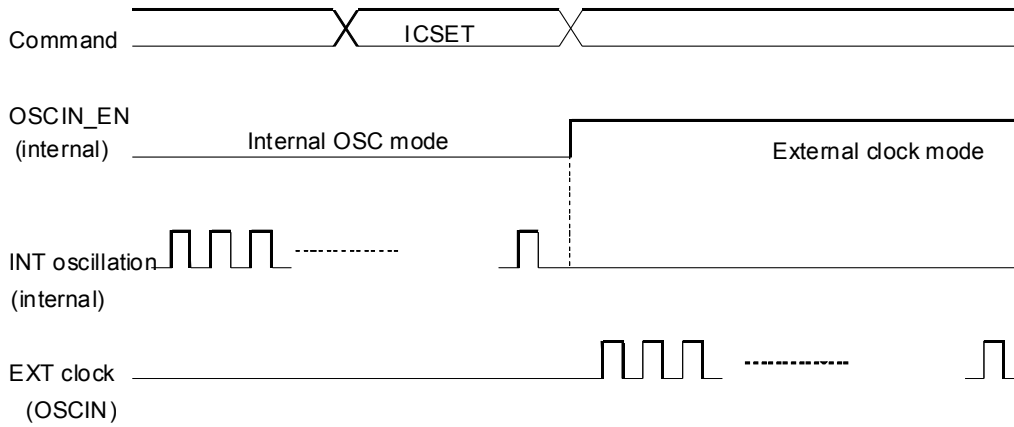

Figure 12. Oscillator mode change timing

○Blink control (BLKCTL)

MSB							LSB
D7	D6	D5	D4	D3	D2	D1	D0
C	1	1	1	0	*	P1	P0

Set blink mode

Blink mode (Hz)	P1	P0	Reset initialize condition
OFF	0	0	○
0.5	0	1	
1	1	0	
2	1	1	

○All Pixel control (APCTL)

MSB							LSB
D7	D6	D5	D4	D3	D2	D1	D0
C	1	1	1	1	1	P1	P0

All display set ON, OFF

APON	P1	Reset initialize condition
Normal	0	○
All pixel ON	1	

APOFF	P0	Reset initialize condition
Normal	0	○
All pixel OFF	1	

All pixels ON : All pixels are ON regardless of DDRAM data
 All pixels OFF : All pixels are OFF regardless of DDRAM data

(Note) This command is valid in Display on status.
 The data of DDRAM don't change by this command. If set both P1 and P0 ="1", APOFF will be select.

○EVR Set 1(EVRSET1)

MSB							LSB
D7	D6	D5	D4	D3	D2	D1	D0
C	1	1	0	0	P2	P1	P0

It is able to control 32-step Electrical Volume Register (EVR).
 It is able to set V0 voltage level (the max level voltage of LCD driving voltage).
 It is set electrical volume register as follows;

MSB				LSB	
EVR4	EVR3	EVR2	EVR1	EVR0	
EVRSET1	EVRSET1	EVRSET1	EVRSET2	EVRSET2	
P2	P1	P0	P1	P0	
0	0	0	0	0	Reset initialize condition

Electrical Volume Register (EVR) is set "00000" in reset initialize condition
 In "00000" condition, V0 voltage output VLCD voltage.
 Please refer to next page about V0 output voltage.
 It is prohibited the EVR setting that V0 voltage will be under 2.5V.

EVRSET1 is defined the upper 3bit of electrical volume register.
 It will be set the electrical volume register by this command (EVRSET1) input.

○EVR Set 2(EVRSET2)

MSB							LSB
D7	D6	D5	D4	D3	D2	D1	D0
C	1	1	1	1	0	P1	P0

EVRSET2 is defined the lower 2bit of electrical volume register.
 It will be set the electrical volume register by this command (EVRSET2) input.

○The relationship of Electrical Volume Register (EVR) setting and V0 voltage

EVR	Calculation formula	VLCD= 5.500	VLCD= 5.000	VLCD= 4.000	VLCD= 3.500	VLCD= 3.000	VLCD= 2.500	[V]
0	VLCD	V0= 5.500	V0= 5.000	V0= 4.000	V0= 3.500	V0= 3.000	V0= 2.500	[V]
1	0.967*VLCD	V0= 5.323	V0= 4.839	V0= 3.871	V0= 3.387	V0= 2.903	V0= 2.419	[V]
2	0.937*VLCD	V0= 5.156	V0= 4.688	V0= 3.750	V0= 3.281	V0= 2.813	V0= 2.344	[V]
3	0.909*VLCD	V0= 5.000	V0= 4.545	V0= 3.636	V0= 3.182	V0= 2.727	V0= 2.273	[V]
4	0.882*VLCD	V0= 4.853	V0= 4.412	V0= 3.529	V0= 3.088	V0= 2.647	V0= 2.206	[V]
5	0.857*VLCD	V0= 4.714	V0= 4.286	V0= 3.429	V0= 3.000	V0= 2.571	V0= 2.143	[V]
6	0.833*VLCD	V0= 4.583	V0= 4.167	V0= 3.333	V0= 2.917	V0= 2.500	V0= 2.083	[V]
7	0.810*VLCD	V0= 4.459	V0= 4.054	V0= 3.243	V0= 2.838	V0= 2.432	V0= 2.027	[V]
8	0.789*VLCD	V0= 4.342	V0= 3.947	V0= 3.158	V0= 2.763	V0= 2.368	V0= 1.974	[V]
9	0.769*VLCD	V0= 4.231	V0= 3.846	V0= 3.077	V0= 2.692	V0= 2.308	V0= 1.923	[V]
10	0.750*VLCD	V0= 4.125	V0= 3.750	V0= 3.000	V0= 2.625	V0= 2.250	V0= 1.875	[V]
11	0.731*VLCD	V0= 4.024	V0= 3.659	V0= 2.927	V0= 2.561	V0= 2.195	V0= 1.829	[V]
12	0.714*VLCD	V0= 3.929	V0= 3.571	V0= 2.857	V0= 2.500	V0= 2.143	V0= 1.786	[V]
13	0.697*VLCD	V0= 3.837	V0= 3.488	V0= 2.791	V0= 2.442	V0= 2.093	V0= 1.744	[V]
14	0.681*VLCD	V0= 3.750	V0= 3.409	V0= 2.727	V0= 2.386	V0= 2.045	V0= 1.705	[V]
15	0.666*VLCD	V0= 3.667	V0= 3.333	V0= 2.667	V0= 2.333	V0= 2.000	V0= 1.667	[V]
16	0.652*VLCD	V0= 3.587	V0= 3.261	V0= 2.609	V0= 2.283	V0= 1.957	V0= 1.630	[V]
17	0.638*VLCD	V0= 3.511	V0= 3.191	V0= 2.553	V0= 2.234	V0= 1.915	V0= 1.596	[V]
18	0.625*VLCD	V0= 3.438	V0= 3.125	V0= 2.500	V0= 2.188	V0= 1.875	V0= 1.563	[V]
19	0.612*VLCD	V0= 3.367	V0= 3.061	V0= 2.449	V0= 2.143	V0= 1.837	V0= 1.531	[V]
20	0.600*VLCD	V0= 3.300	V0= 3.000	V0= 2.400	V0= 2.100	V0= 1.800	V0= 1.500	[V]
21	0.588*VLCD	V0= 3.235	V0= 2.941	V0= 2.353	V0= 2.059	V0= 1.765	V0= 1.471	[V]
22	0.576*VLCD	V0= 3.173	V0= 2.885	V0= 2.308	V0= 2.019	V0= 1.731	V0= 1.442	[V]
23	0.566*VLCD	V0= 3.113	V0= 2.830	V0= 2.264	V0= 1.981	V0= 1.698	V0= 1.415	[V]
24	0.555*VLCD	V0= 3.056	V0= 2.778	V0= 2.222	V0= 1.944	V0= 1.667	V0= 1.389	[V]
25	0.545*VLCD	V0= 3.000	V0= 2.727	V0= 2.182	V0= 1.909	V0= 1.636	V0= 1.364	[V]
26	0.535*VLCD	V0= 2.946	V0= 2.679	V0= 2.143	V0= 1.875	V0= 1.607	V0= 1.339	[V]
27	0.526*VLCD	V0= 2.895	V0= 2.632	V0= 2.105	V0= 1.842	V0= 1.579	V0= 1.316	[V]
28	0.517*VLCD	V0= 2.845	V0= 2.586	V0= 2.069	V0= 1.810	V0= 1.552	V0= 1.293	[V]
29	0.508*VLCD	V0= 2.797	V0= 2.542	V0= 2.034	V0= 1.780	V0= 1.525	V0= 1.271	[V]
30	0.500*VLCD	V0= 2.750	V0= 2.500	V0= 2.000	V0= 1.750	V0= 1.500	V0= 1.250	[V]
31	0.491*VLCD	V0= 2.705	V0= 2.459	V0= 1.967	V0= 1.721	V0= 1.475	V0= 1.230	[V]

 Prohibit setting

●LCD driving waveform

(1/3bias)

Line inversion

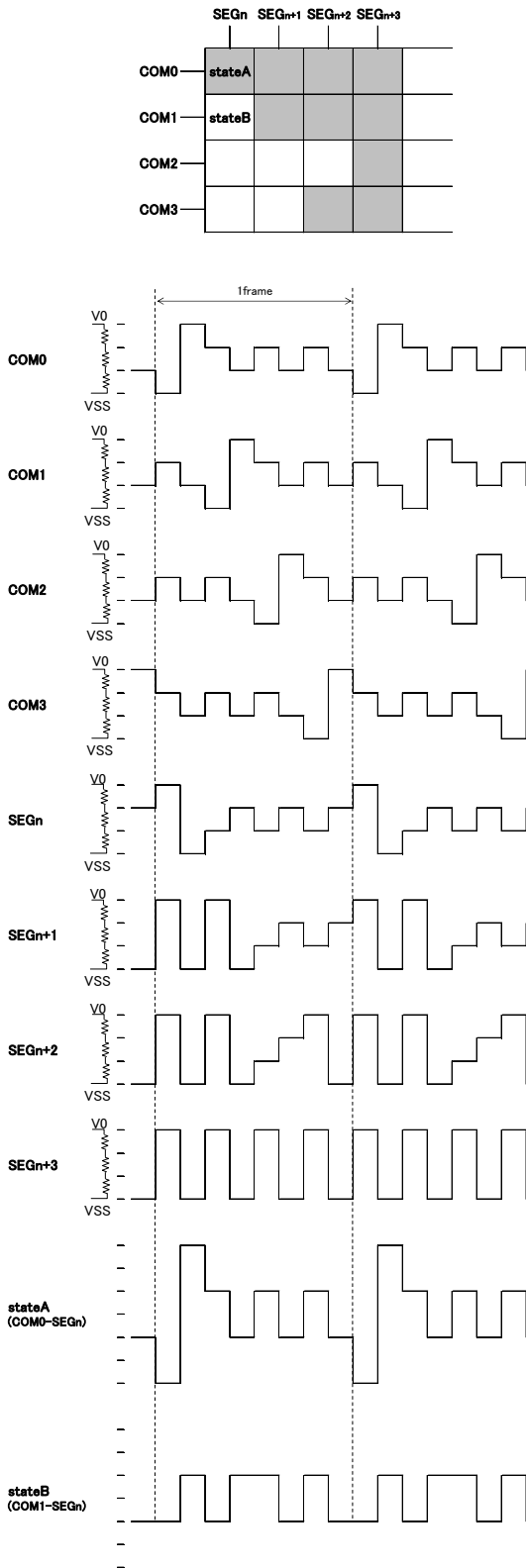

Figure 13. LCD waveform at line inversion (1/3bias)

Frame inversion

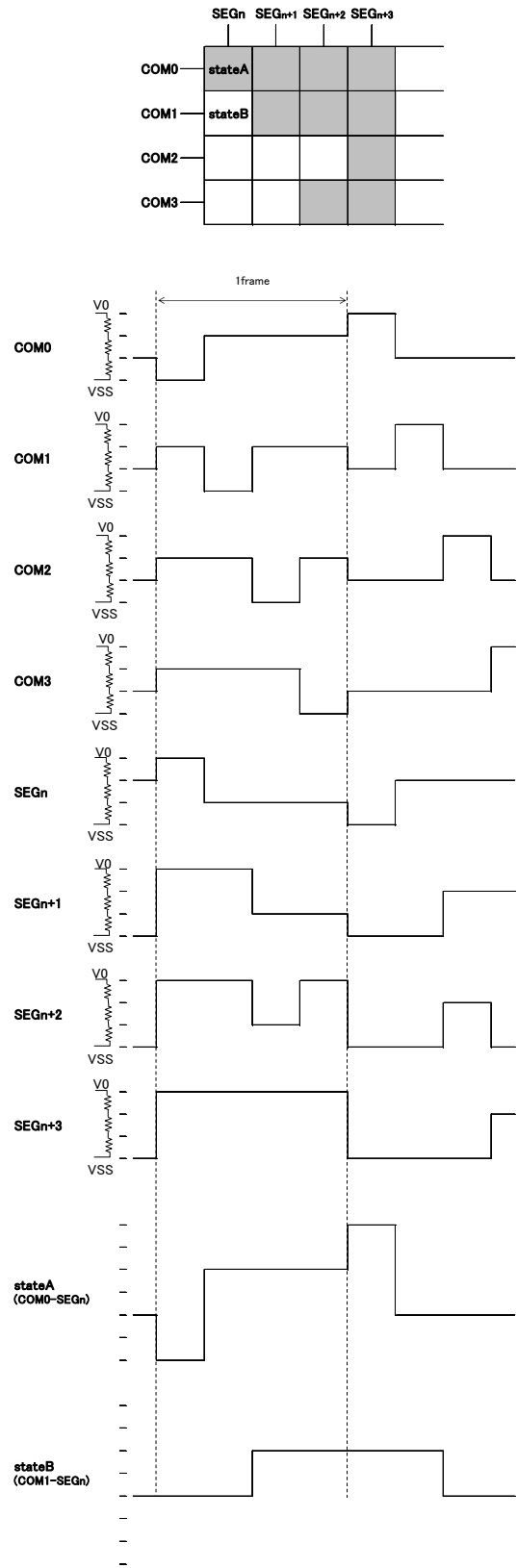

Figure 14. LCD waveform at frame inversion (1/3bias)

(1/2bias)

Line inversion

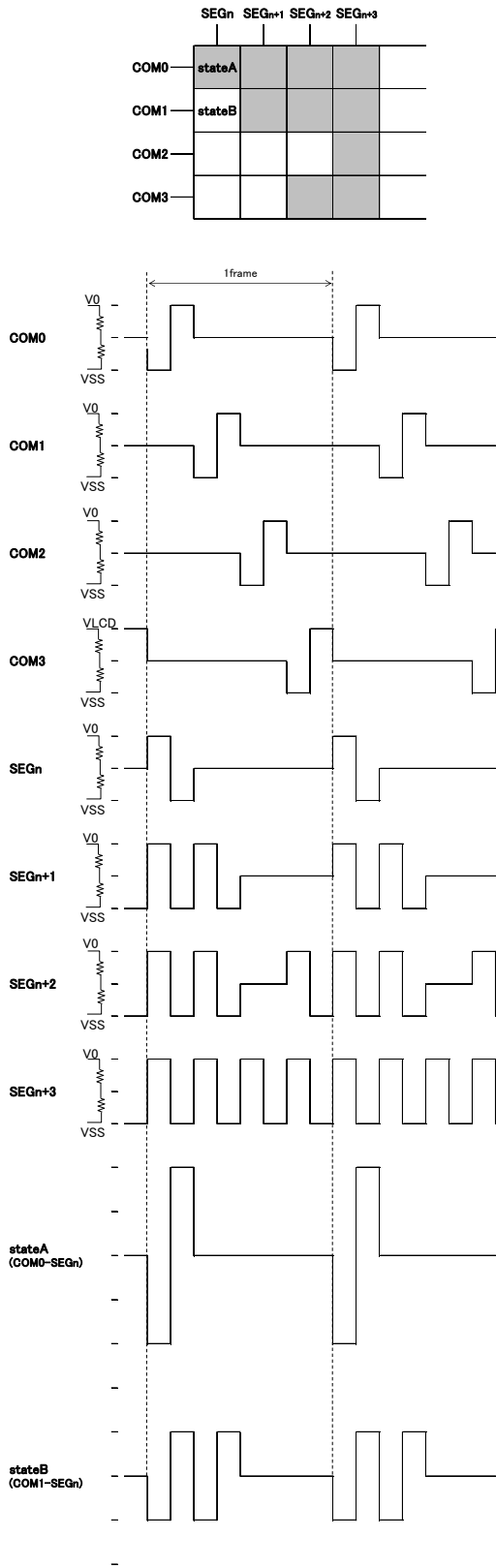

Figure 15. LCD waveform in line inversion (1/2bias)

Frame inversion

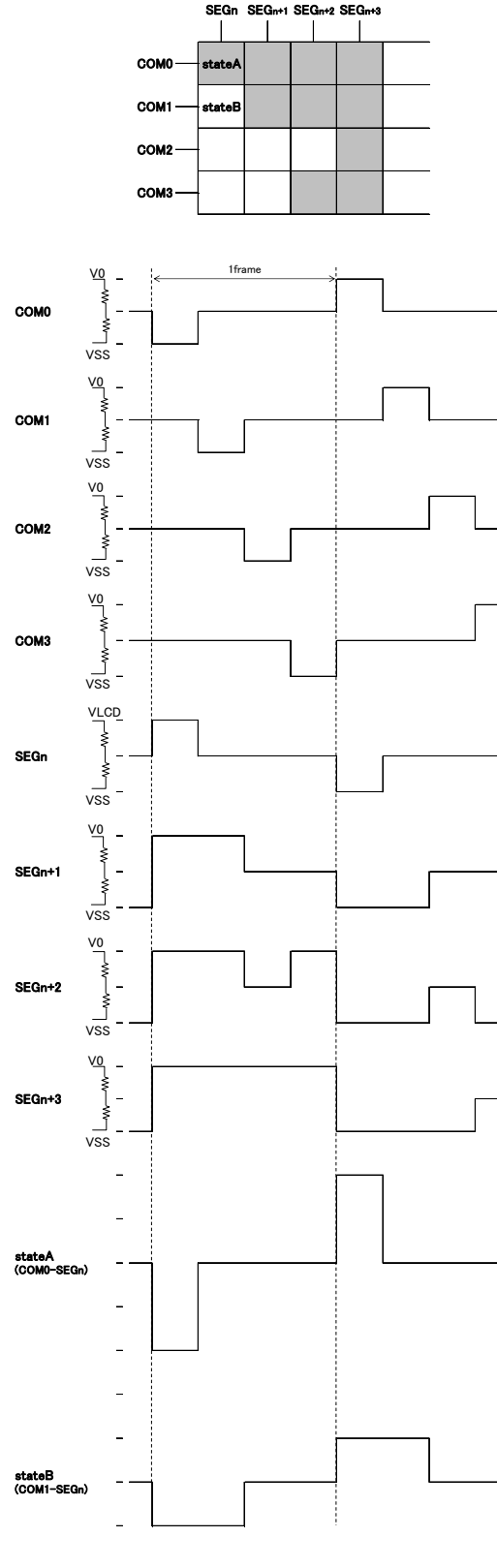

Figure 16. LCD waveform in frame inversion (1/2bias)

●Example of display data

If LCD layout pattern is like as Figure 17, Figure 18, and display pattern is like as Figure 19. Display data will be shown as follows;

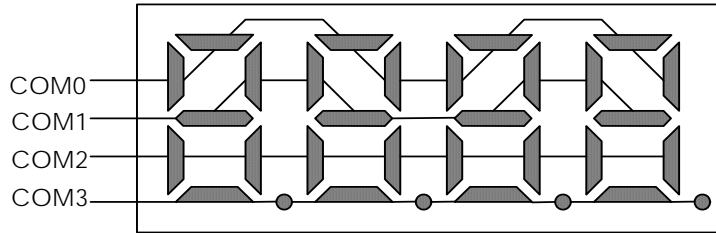

Figure 17. Example COM line pattern

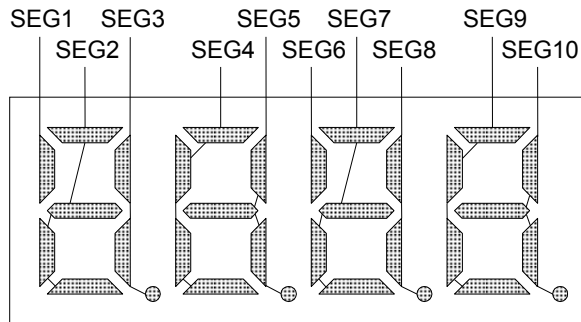

Figure 18. Example SEG line pattern

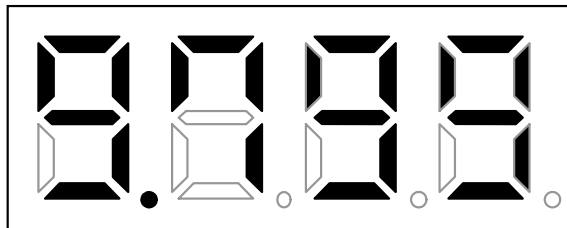

Figure 19. Example Display pattern

<DDRAM data mapping in Figure 19 display pattern>

		S	S	S	S	S	S	S	S	S	S	S	S	S	S	S	S	S	S	S	
		E	E	E	E	E	E	E	E	E	E	E	E	E	E	E	E	E	E	E	
		G	G	G	G	G	G	G	G	G	G	G	G	G	G	G	G	G	G	G	
		0	1	2	3	4	5	6	7	8	9	10	11	12	13	14	15	16	17	18	19
COM0	D0	0	1	1	0	1	1	1	1	0	1	1	0	0	0	0	0	0	0	0	0
COM1	D1	0	0	1	1	1	0	0	1	1	1	1	0	0	0	0	0	0	0	0	0
COM2	D2	0	0	0	1	0	1	0	0	1	0	1	0	0	0	0	0	0	0	0	0
COM3	D3	0	0	1	1	0	0	0	1	0	1	0	0	0	0	0	0	0	0	0	0
Address		00h	01h	02h	03h	04h	05h	06h	07h	08h	09h	0Ah	0Bh	0Ch	0Dh	0Eh	0Fh	10h	11h	12h	13h

●Initialize sequence

Please follow below sequence after Power-on to set this LSI to initial condition.

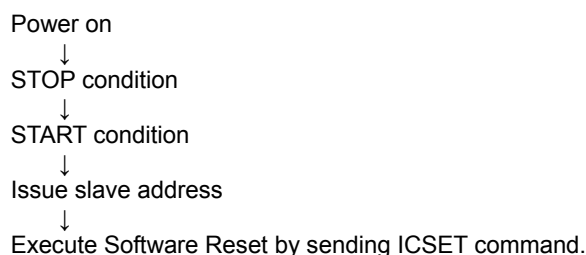

*Each register value and DDRAM address, DDRAM data are random condition after power on till initialize sequence is executed.

●Start sequence

○Start sequence example1

No.	Input	D7	D6	D5	D4	D3	D2	D1	D0	Descriptions
1	Power on									VDD=0→5V (Tr=0.1ms)
	↓									
2	wait 100μs									Initialize IC
	↓									
3	Stop									Stop condition
	↓									
4	Start									Start condition
	↓									
5	Slave address	0	1	1	1	1	1	0	0	Issue slave address
	↓									
6	ICSET	1	1	1	0	1	*	1	0	Software Reset
	↓									
7	BLKCTL	1	1	1	1	0	*	0	1	
	↓									
8	DISCTL	1	0	1	0	0	0	0	0	
	↓									
9	EVRSET1	1	1	1	0	0	0	0	1	
10	EVRSET2	1	1	1	1	1	0	0	1	
	↓									
11	ICSET	1	1	1	0	1	*	0	1	
	↓									
12	ADSET	0	0	0	0	0	0	0	0	RAM address set
	↓									
13	Display Data	*	*	*	*	*	*	*	*	address 00h - 01h
	Display Data	*	*	*	*	*	*	*	*	address 02h - 03h
	⋮									⋮
	Display Data	*	*	*	*	*	*	*	*	address 12h - 13h
	↓									
14	Stop									Stop condition
	↓									
15	Start									Start condition
	↓									
16	Slave address	0	1	1	1	1	1	0	0	Issue slave address
	↓									
17	MODESET	1	1	0	0	1	0	*	*	Display ON
	↓									
18	Stop									Stop condition

○Start sequence example2

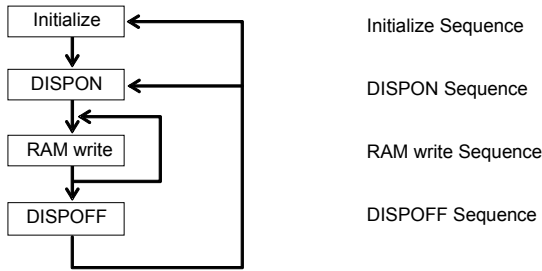

This LSI is initialized with Initialize Sequence. And start to display with DISPON Sequence.
 This LSI will update display data with RAM write Sequence.
 And stop the display with DISPOFF sequence.
 If you want to restart to display, This LSI will restart to display with DISPON Sequence.

Initialize sequence

Input	DATA								Description	
	D7	D6	D5	D4	D3	D2	D1	D0		
Power on wait 100us STOP START										
Slave address	0	1	1	1	1	1	0	0		Execute Software Reset
ICSET	1	1	1	0	1	0	1	0		Display OFF
MODESET	1	1	0	0	0	0	0	0		RAM address set
ADSET	0	0	0	0	0	0	0	0		Display data
Display data	*	*	*	*	*	*	*	*		
...										
STOP										

DISPON sequence

Input	DATA								Description	
	D7	D6	D5	D4	D3	D2	D1	D0		
START										
Slave address	0	1	1	1	1	1	0	0		Execute internal OSC mode
ICSET	1	1	1	0	1	0	0	1		Set Display Control
DISCTL	1	0	1	1	1	1	1	1		Set BLKCTL
BLKCTL	1	1	1	1	0	0	0	0		Set APCTL
APCTL	1	1	1	1	1	1	0	0		Set EVR1
EVRSET1	1	1	1	0	0	0	0	0		Set EVR2
EVRSET2	1	1	1	1	1	0	0	0		Display ON
MODESET	1	1	0	0	1	0	0	0		
STOP										

RAM write sequence

Input	DATA								Description	
	D7	D6	D5	D4	D3	D2	D1	D0		
START										
Slave address	0	1	1	1	1	1	0	0		Execute internal OSC mode
ICSET	1	1	1	0	1	0	0	1		Set Display Control
DISCTL	1	0	1	1	1	1	1	1		Set BLKCTL
BLKCTL	1	1	1	1	0	0	0	0		Set APCTL
APCTL	1	1	1	1	1	1	0	0		Set EVR1
EVRSET1	1	1	1	0	0	0	0	0		Set EVR2
EVRSET2	1	1	1	1	1	0	0	0		Display ON
MODESET	1	1	0	0	1	0	0	0		RAM address set
ADSET	0	0	0	0	0	0	0	0		Display data
Display Data	*	*	*	*	*	*	*	*		
...										
STOP										

DISPOFF sequence

Input	DATA								Description	
	D7	D6	D5	D4	D3	D2	D1	D0		
START										
Slave address	0	1	1	1	1	1	0	0		Execute internal OSC mode
ICSET	1	1	1	0	1	0	0	1		Display OFF
MODESET	1	1	0	0	0	0	0	0		
STOP										

According to the effect of noise or other external factor, BU9799KV occur abnormal operation.
 To avoid this phenomenon, please input command according to upper sequence certainly,
 when initializing IC, displaying ON/OFF, and refreshing RAM data.

●DISCTL setup flow chart

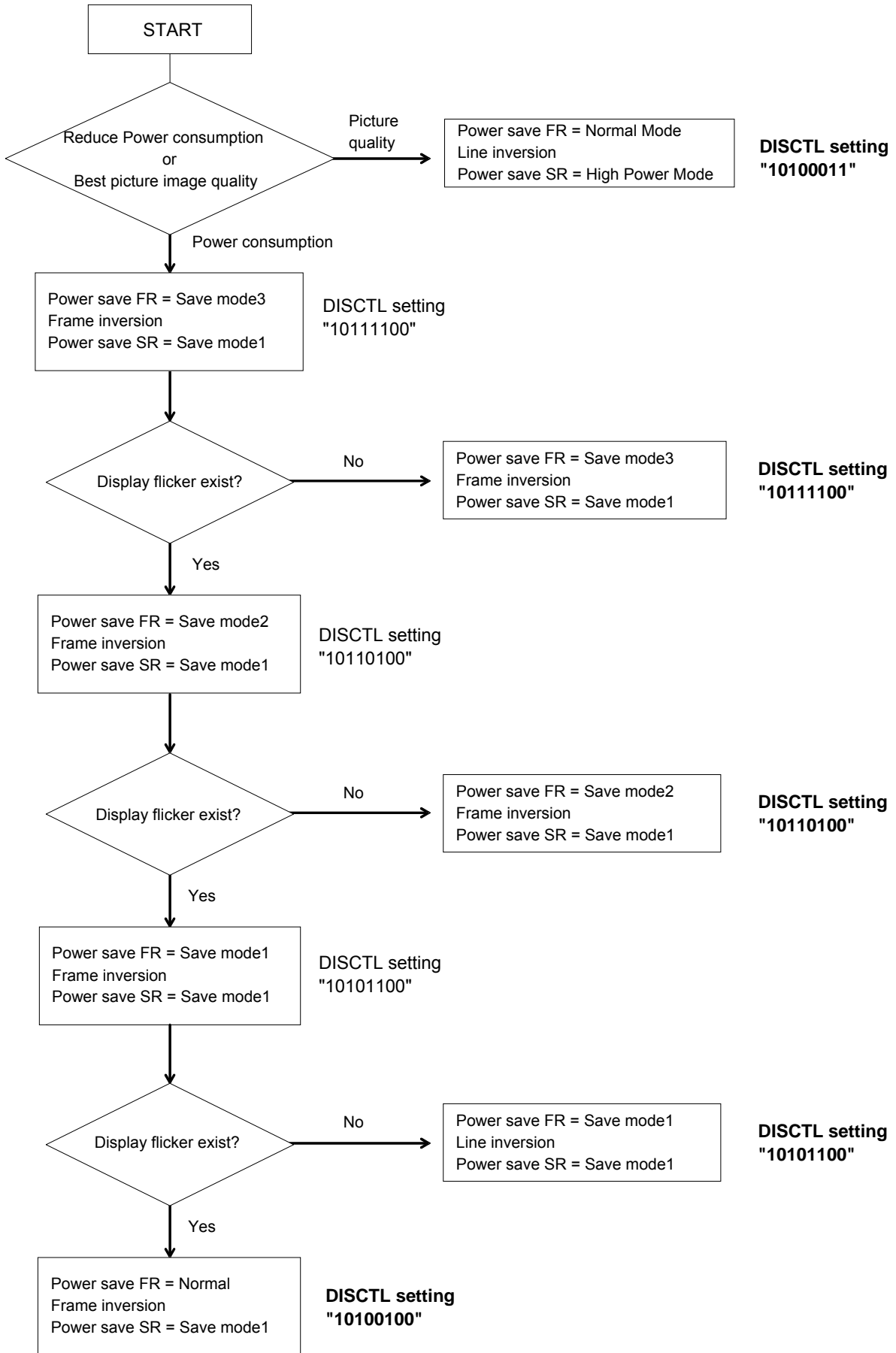

●Cautions in Power ON/OFF

○Power supply sequence

Please keep Power ON/OFF sequence as below waveform.
 To prevent incorrect display, malfunction and abnormal current,
 VDD must be turned on before VLCD in power up sequence.
 VDD must be turned off after VLCD in power down sequence.
 Please satisfies VLCD≥VDD, t1>0ns, t2>0ns

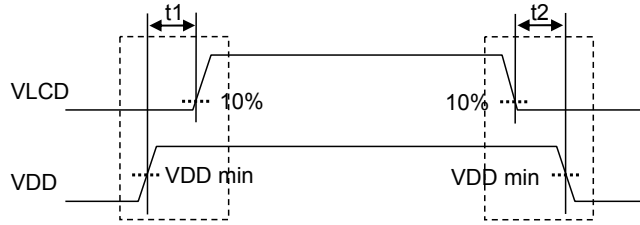

Figure 20. Power supply sequence

○Caution in P.O.R circuit use

This device has “P.O.R” (Power-On Reset) circuit and Software Reset function.
 Please keep the following recommended Power-On conditions in order to power up properly.

Please set power up conditions to meet the recommended tR, tF, tOFF, and Vbot spec below in order to ensure P.O.R operation

*It has to set TEST1="L" to be valid in POR circuit.

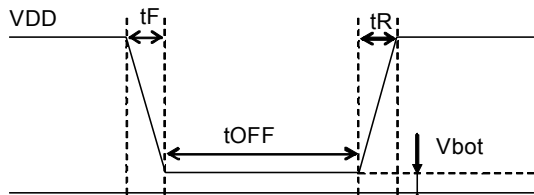

Recommended condition of tR, tF, tOFF, Vbot (Ta=25°C)

tR	tF	tOFF	Vbot
Less than 5ms	Less than 5ms	More than 20ms	Less than 0.3V

Figure 21. Power ON/OFF waveform

If it is difficult to meet above conditions, execute the following sequence after Power-On.

*It has to keep the following sequence in the case of TEST1="H". As POR circuit is invalid status.

- (1) TEST1 ="H"

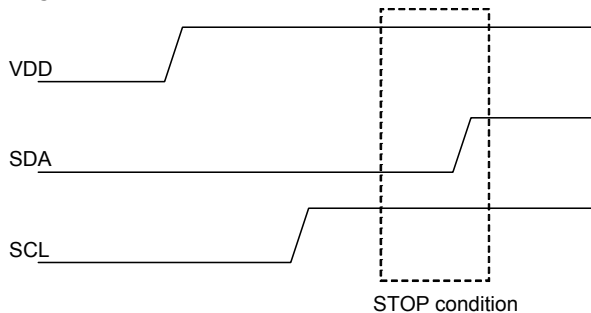

Figure 22. Stop condition

- (2) Generate STOP condition
- (3) Generate START condition
- (4) Issue slave address
- (5) Execute ICSET command (Software reset).
 Refer to the item of the ICSET command for the details.

●Operational Notes

- (1) Absolute Maximum Ratings
Operating the IC over the absolute maximum ratings may damage the IC. The damage can either be a short circuit between pins or an open circuit between pins. Therefore, it is important to consider circuit protection measures, such as adding a fuse, in case the IC is operated over the absolute maximum ratings.
- (2) Recommended Operating conditions
These conditions represent a range within which the expected characteristics of the IC can be approximately obtained. The electrical characteristics are guaranteed under the conditions of each parameter.
- (3) Reverse Connection of Power Supply
Connecting the power supply in reverse polarity can damage the IC. Take precautions against reverse polarity when connecting the power supply, such as mounting an external diode between the power supply and the IC's power supply terminals.
- (4) Power Supply Lines
Design the PCB layout pattern to provide low impedance ground and supply lines. Separate the ground and supply lines of the digital and analog blocks to prevent noise in the ground and supply lines of the digital block from affecting the analog block. Furthermore, connect a capacitor to ground at all power supply pins. Consider the effect of temperature and aging on the capacitance value when using electrolytic capacitors.
- (5) Ground Voltage
The voltage of the ground pin must be the lowest voltage of all pins of the IC at all operating conditions. Ensure that no pins are at a voltage below the ground pin at any time, even during transient condition.
- (6) Short between Pins and Mounting Errors
Be careful when mounting the IC on printed circuit boards. The IC may be damaged if it is mounted in a wrong orientation or if pins are shorted together. Short circuit may be caused by conductive particles caught between the pins.
- (7) Operation under Strong Electromagnetic Field
Operating the IC in the presence of a strong electromagnetic field may cause the IC to malfunction.
- (8) Testing on Application Boards
When testing the IC on an application board, connecting a capacitor directly to a low-impedance output pin may subject the IC to stress. Always discharge capacitors completely after each process or step. The IC's power supply should always be turned off completely before connecting or removing it from the test setup during the inspection process. To prevent damage from static discharge, ground the IC during assembly and use similar precautions during transport and storage.
- (9) Regarding Input Pins of the IC
In the construction of this IC, P-N junctions are inevitably formed creating parasitic diodes or transistors. The operation of these parasitic elements can result in mutual interference among circuits, operational faults, or physical damage. Therefore, conditions which cause these parasitic elements to operate, such as applying a voltage to an input pin lower than the GND voltage should be avoided. Furthermore, do not apply a voltage to the input terminals when no power supply voltage is applied to the IC. Even if the power supply voltage is applied, make sure that the input terminals have voltages within the values specified in the electrical characteristics of this IC..
- (10) GND Wiring Pattern
When using both small-signal and large-current GND traces, the two ground traces should be routed separately but connected to a single ground at the reference point of the application board to avoid fluctuations in the small-signal ground caused by large currents. Also ensure that the GND traces of external components do not cause variations on the GND voltage. The power supply and ground lines must be as short and thick as possible to reduce line impedance.
- (11) External Capacitor
When using a ceramic capacitor, determine the dielectric constant considering the change of capacitance with temperature and the decrease in nominal capacitance due to DC bias and others.
- (12) Unused Input Terminals
Input terminals of an IC are often connected to the gate of a CMOS transistor. The gate has extremely high impedance and extremely low capacitance. If left unconnected, the electric field from the outside can easily charge it. The small charge acquired in this way is enough to produce a significant effect on the conduction through the transistor and cause unexpected operation of IC. So unless otherwise specified, input terminals not being used should be connected to the power supply or ground line.
- (13) Rush current
When power is first supplied to the IC, rush current may flow instantaneously. It is possible that the charge current to the parasitic capacitance of internal photo diode or the internal logic may be unstable. Therefore, give special consideration to power coupling capacitance, power wiring, width of GND wiring, and routing of connections.

●Ordering Information

B U 9 7 9 9 K V		-	E 2
Part Number	Package KV : VQFP64	Packaging and forming specification E2: Embossed tape and reel (VQFP64)	

●Marking Diagram

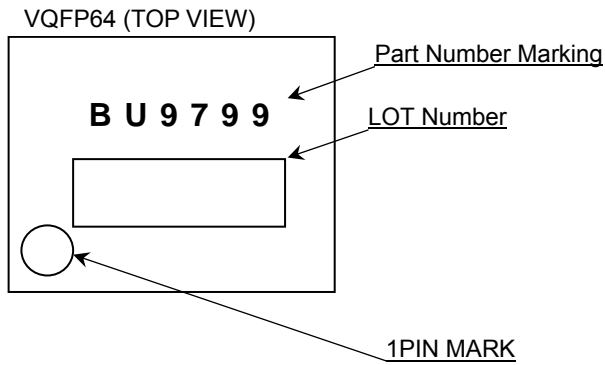

●Physical Dimension, Tape and Reel Information

Package Name	VQFP64
--------------	--------

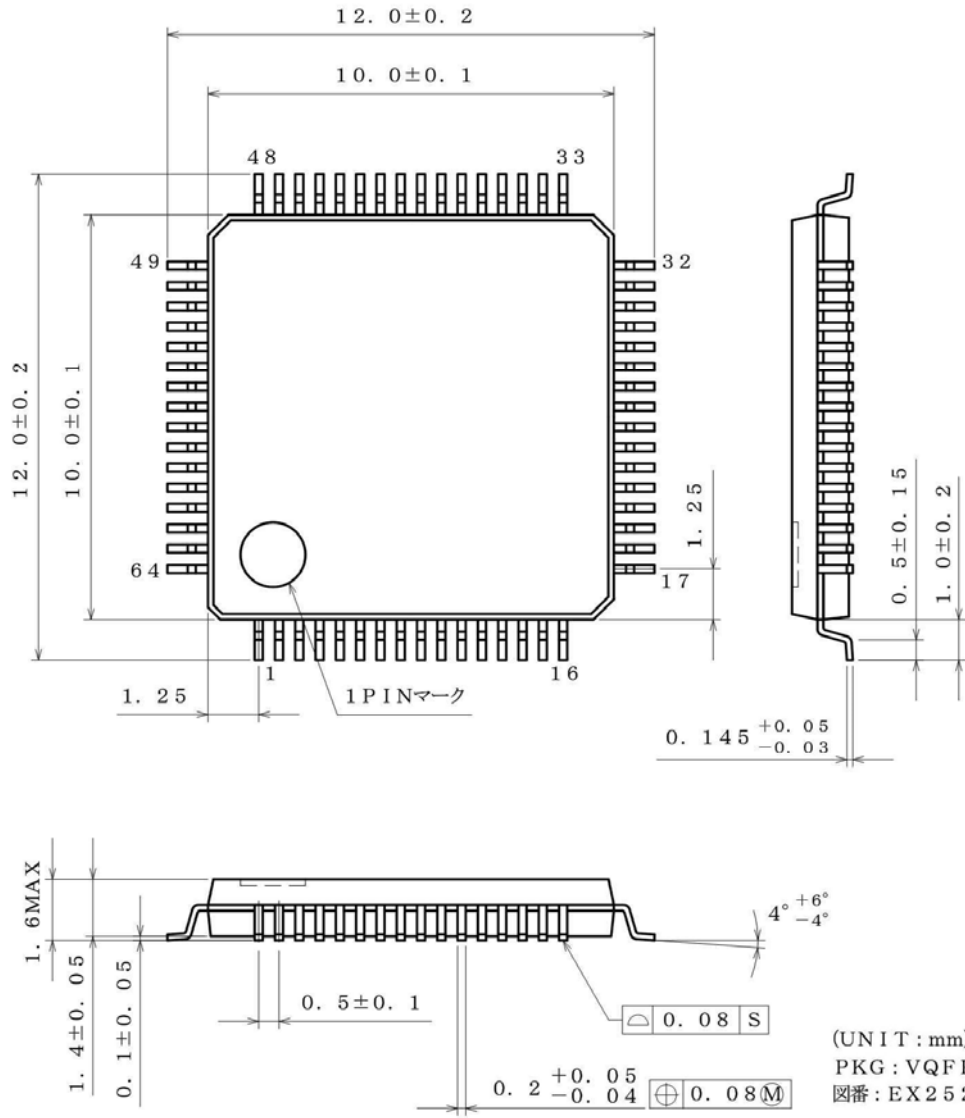

(UNIT : mm)
 PKG : VQFP64
 図番 : EX252-5001-1

<Tape and Reel information>

Tape	Embossed carrier tape (with dry pack)
Quantity	1000pcs
Direction of feed	E2 (The direction is the 1pin of product is at the upper left when you hold reel on the left hand and you pull out the tape on the right hand)

*Order quantity needs to be multiple of the minimum quantity.

●Revision History

Date	Revision	Changes
14.Mar.2012	001	New Release
8.Jan.2013	002	Improved the statement in all pages. Deleted "Status of this document" in page 23. Changed format of Physical Dimension, Tape and Reel Information.
23.Jan.2015	003	Add the condition when power supply in page 20.

Notice

Precaution on using ROHM Products

- Our Products are designed and manufactured for application in ordinary electronic equipments (such as AV equipment, OA equipment, telecommunication equipment, home electronic appliances, amusement equipment, etc.). If you intend to use our Products in devices requiring extremely high reliability (such as medical equipment ^(Note 1), transport equipment, traffic equipment, aircraft/spacecraft, nuclear power controllers, fuel controllers, car equipment including car accessories, safety devices, etc.) and whose malfunction or failure may cause loss of human life, bodily injury or serious damage to property ("Specific Applications"), please consult with the ROHM sales representative in advance. Unless otherwise agreed in writing by ROHM in advance, ROHM shall not be in any way responsible or liable for any damages, expenses or losses incurred by you or third parties arising from the use of any ROHM's Products for Specific Applications.

(Note1) Medical Equipment Classification of the Specific Applications

JAPAN	USA	EU	CHINA
CLASS III	CLASS III	CLASS II b	CLASS III
CLASS IV		CLASS III	

- ROHM designs and manufactures its Products subject to strict quality control system. However, semiconductor products can fail or malfunction at a certain rate. Please be sure to implement, at your own responsibilities, adequate safety measures including but not limited to fail-safe design against the physical injury, damage to any property, which a failure or malfunction of our Products may cause. The following are examples of safety measures:
 - Installation of protection circuits or other protective devices to improve system safety
 - Installation of redundant circuits to reduce the impact of single or multiple circuit failure
- Our Products are designed and manufactured for use under standard conditions and not under any special or extraordinary environments or conditions, as exemplified below. Accordingly, ROHM shall not be in any way responsible or liable for any damages, expenses or losses arising from the use of any ROHM's Products under any special or extraordinary environments or conditions. If you intend to use our Products under any special or extraordinary environments or conditions (as exemplified below), your independent verification and confirmation of product performance, reliability, etc. prior to use, must be necessary:
 - Use of our Products in any types of liquid, including water, oils, chemicals, and organic solvents
 - Use of our Products outdoors or in places where the Products are exposed to direct sunlight or dust
 - Use of our Products in places where the Products are exposed to sea wind or corrosive gases, including Cl₂, H₂S, NH₃, SO₂, and NO₂
 - Use of our Products in places where the Products are exposed to static electricity or electromagnetic waves
 - Use of our Products in proximity to heat-producing components, plastic cords, or other flammable items
 - Sealing or coating our Products with resin or other coating materials
 - Use of our Products without cleaning residue of flux (even if you use no-clean type fluxes, cleaning residue of flux is recommended); or Washing our Products by using water or water-soluble cleaning agents for cleaning residue after soldering
 - Use of the Products in places subject to dew condensation
- The Products are not subject to radiation-proof design.
- Please verify and confirm characteristics of the final or mounted products in using the Products.
- In particular, if a transient load (a large amount of load applied in a short period of time, such as pulse. is applied, confirmation of performance characteristics after on-board mounting is strongly recommended. Avoid applying power exceeding normal rated power; exceeding the power rating under steady-state loading condition may negatively affect product performance and reliability.
- De-rate Power Dissipation depending on ambient temperature. When used in sealed area, confirm that it is the use in the range that does not exceed the maximum junction temperature.
- Confirm that operation temperature is within the specified range described in the product specification.
- ROHM shall not be in any way responsible or liable for failure induced under deviant condition from what is defined in this document.

Precaution for Mounting / Circuit board design

- When a highly active halogenous (chlorine, bromine, etc.) flux is used, the residue of flux may negatively affect product performance and reliability.
- In principle, the reflow soldering method must be used on a surface-mount products, the flow soldering method must be used on a through hole mount products. If the flow soldering method is preferred on a surface-mount products, please consult with the ROHM representative in advance.

For details, please refer to ROHM Mounting specification

Precautions Regarding Application Examples and External Circuits

1. If change is made to the constant of an external circuit, please allow a sufficient margin considering variations of the characteristics of the Products and external components, including transient characteristics, as well as static characteristics.
2. You agree that application notes, reference designs, and associated data and information contained in this document are presented only as guidance for Products use. Therefore, in case you use such information, you are solely responsible for it and you must exercise your own independent verification and judgment in the use of such information contained in this document. ROHM shall not be in any way responsible or liable for any damages, expenses or losses incurred by you or third parties arising from the use of such information.

Precaution for Electrostatic

This Product is electrostatic sensitive product, which may be damaged due to electrostatic discharge. Please take proper caution in your manufacturing process and storage so that voltage exceeding the Products maximum rating will not be applied to Products. Please take special care under dry condition (e.g. Grounding of human body / equipment / solder iron, isolation from charged objects, setting of Ionizer, friction prevention and temperature / humidity control).

Precaution for Storage / Transportation

1. Product performance and soldered connections may deteriorate if the Products are stored in the places where:
 - [a] the Products are exposed to sea winds or corrosive gases, including Cl₂, H₂S, NH₃, SO₂, and NO₂
 - [b] the temperature or humidity exceeds those recommended by ROHM
 - [c] the Products are exposed to direct sunshine or condensation
 - [d] the Products are exposed to high Electrostatic
2. Even under ROHM recommended storage condition, solderability of products out of recommended storage time period may be degraded. It is strongly recommended to confirm solderability before using Products of which storage time is exceeding the recommended storage time period.
3. Store / transport cartons in the correct direction, which is indicated on a carton with a symbol. Otherwise bent leads may occur due to excessive stress applied when dropping of a carton.
4. Use Products within the specified time after opening a humidity barrier bag. Baking is required before using Products of which storage time is exceeding the recommended storage time period.

Precaution for Product Label

QR code printed on ROHM Products label is for ROHM's internal use only.

Precaution for Disposition

When disposing Products please dispose them properly using an authorized industry waste company.

Precaution for Foreign Exchange and Foreign Trade act

Since concerned goods might be fallen under listed items of export control prescribed by Foreign exchange and Foreign trade act, please consult with ROHM in case of export.

Precaution Regarding Intellectual Property Rights

1. All information and data including but not limited to application example contained in this document is for reference only. ROHM does not warrant that foregoing information or data will not infringe any intellectual property rights or any other rights of any third party regarding such information or data.
2. ROHM shall not have any obligations where the claims, actions or demands arising from the combination of the Products with other articles such as components, circuits, systems or external equipment (including software).
3. No license, expressly or implied, is granted hereby under any intellectual property rights or other rights of ROHM or any third parties with respect to the Products or the information contained in this document. Provided, however, that ROHM will not assert its intellectual property rights or other rights against you or your customers to the extent necessary to manufacture or sell products containing the Products, subject to the terms and conditions herein.

Other Precaution



1. This document may not be reprinted or reproduced, in whole or in part, without prior written consent of ROHM.
2. The Products may not be disassembled, converted, modified, reproduced or otherwise changed without prior written consent of ROHM.
3. In no event shall you use in any way whatsoever the Products and the related technical information contained in the Products or this document for any military purposes, including but not limited to, the development of mass-destruction weapons.
4. The proper names of companies or products described in this document are trademarks or registered trademarks of ROHM, its affiliated companies or third parties.

General Precaution

1. Before you use our Products, you are requested to carefully read this document and fully understand its contents. ROHM shall not be in any way responsible or liable for failure, malfunction or accident arising from the use of any ROHM's Products against warning, caution or note contained in this document.
2. All information contained in this document is current as of the issuing date and subject to change without any prior notice. Before purchasing or using ROHM's Products, please confirm the latest information with a ROHM sales representative.
3. The information contained in this document is provided on an "as is" basis and ROHM does not warrant that all information contained in this document is accurate and/or error-free. ROHM shall not be in any way responsible or liable for any damages, expenses or losses incurred by you or third parties resulting from inaccuracy or errors of or concerning such information.

Looking for pricing, stock, or lifecycle information?

Click below to explore more details on WIN SOURCE:

-  [View BU9799KV-E2 on WIN SOURCE](#)
-  [Rohm Semiconductor](#) Information

Optimize Your Supply Chain with WIN SOURCE Solutions

-  Global Sourcing Solution
-  Obsolete Management
-  Cost Control Management
-  Shortage Management
-  Alternative Solution
-  Excess Inventory Management