

# Picture cell driver for STN (LCD driver)

## BU9716BK / BU9716BKV

The BU9716BK and BU9716BKV are man-machine interface ICs designed for applications such as multi-media portable terminals.

Specifically, these products are used as driver ICs for operating mode display LCD panels in portable terminals, household appliances, and other similar products. The number of display cells includes 32 segments and 3 commons, enabling drive of up to 96 cells.

### ●Applications

Multi-media portable terminals, POS terminals, ECR terminals, short wave radios, telephones, cameras, VCRs, movie projectors, car audio systems, and others

### ●Features

- 1) Up to 32 segment outputs and 3 common outputs can be displayed, for a total of 96 segments.
- 2) 1 / 3 duty display.
- 3) Either 1 / 2 or 1 / 3 can be selected for power supply for LCD display.

### ●Absolute maximum ratings (Ta = 25°C, V<sub>SS</sub> = 0V)

Parameter	Symbol	Limits	Unit
Power supply voltage	V <sub>DD</sub>	- 0.3 ~ + 7.0	V
Power dissipation	BU9716BK	500*1	mW
	BU9716BKV	400*2	
Input voltage	V <sub>IN</sub>	- 0.3 ~ V <sub>DD</sub> + 0.3	V
Operating temperature	Topr	- 40 ~ + 85	°C
Storage temperature	Tstg	- 55 ~ + 125	°C

\*1 Reduced by 5mW for each increase in Ta of 1°C over 25°C .

\*2 Reduced by 4mW for each increase in Ta of 1°C over 25°C .

### ●Recommended operating conditions (Ta = 25°C, V<sub>SS</sub> = 0V)

Parameter	Symbol	Min.	Typ.	Max.	Unit
Power supply voltage	V <sub>DD</sub>	4.5	—	5.5	V
Input voltage	V <sub>DD1</sub>	0	2 / 3V <sub>DD</sub>	V <sub>DD</sub>	V
	V <sub>DD2</sub>	0	1 / 3V <sub>DD</sub>	V <sub>DD</sub>	V

●Block diagram

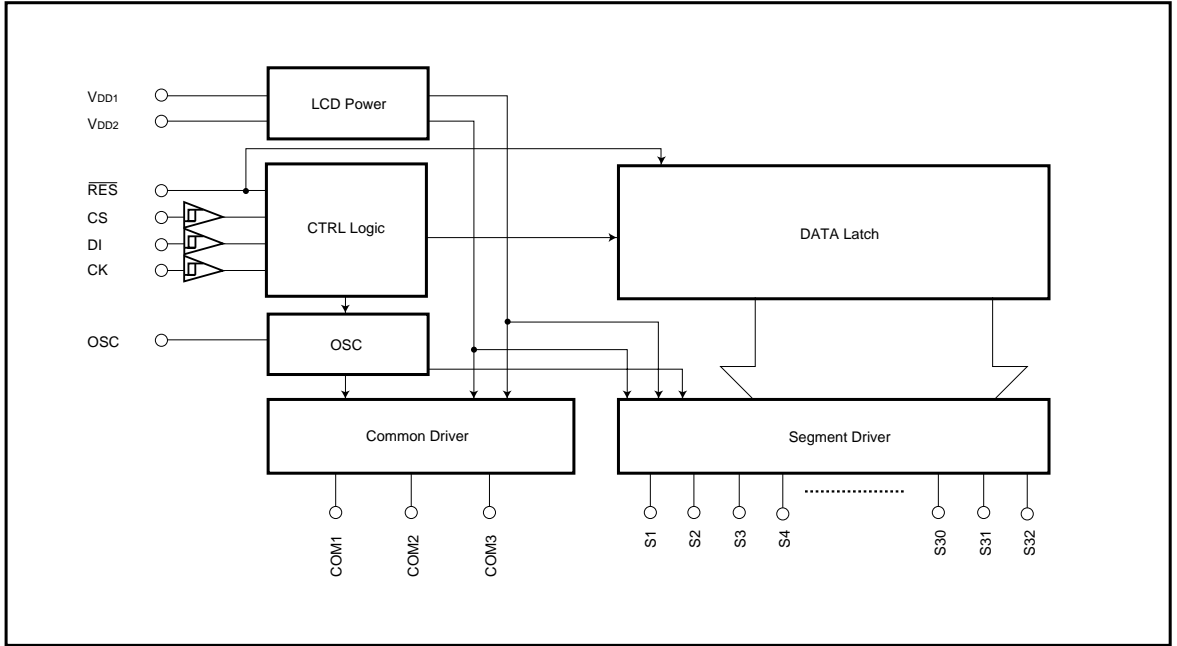

●Pin assignments

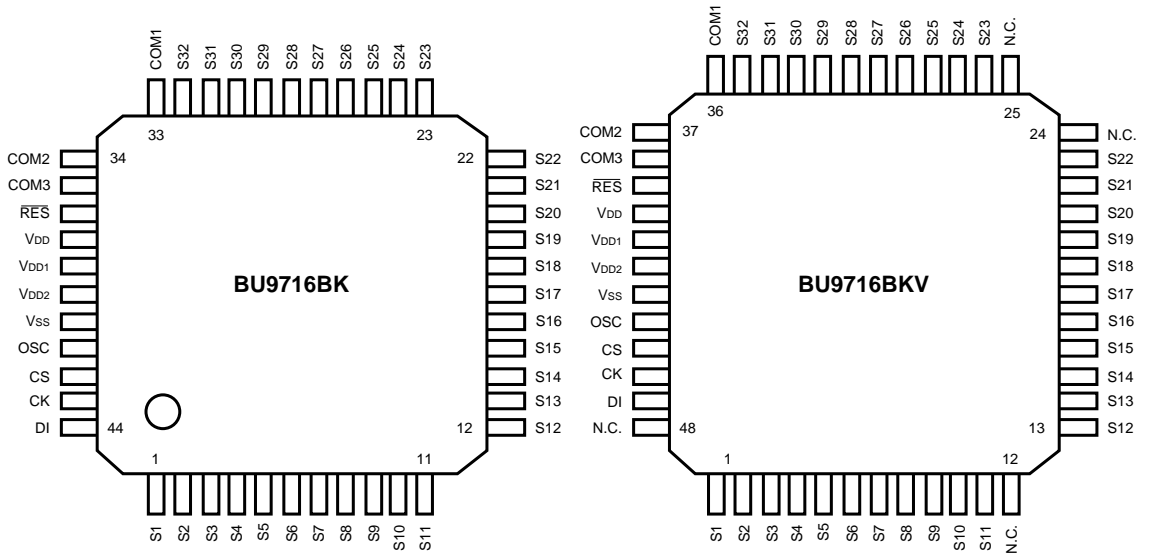

## ●Pin descriptions (BU9716BK)

Pin No.	Pin name	I / O	Function	Processing when not used
1 - 32	S1 - S32	O	Output pin for segment data. Outputs consistent LCD drive voltage to the data corresponding to COM1 to COM3.	OPEN
33 34 35	COM1 COM2 COM3	O	Common driver output. The frame frequency is $f_c = (f_{osc} / 384)$ Hz	OPEN
36	$\overline{RES}$	I	Reset input. At $\overline{RES} = L$ , internal data (including control data) is reset.	$V_{DD}$
41	OSC	—	Oscillator pin (for common and segment alternating waveforms)	$V_{SS}$
42	CS	I	Chip select input. At $CS = H$ , data can be transferred.	$V_{SS}$
43	CK	I	Synchronous clock input for serial data transfer	$V_{SS}$
44	DI	I	Serial data input	$V_{SS}$
38	$V_{DD1}$	—	Internal reference voltage for LCD drive. In 1 / 2 bias mode, this is connected to $V_{DD2}$ .	OPEN
39	$V_{DD2}$	—	Internal reference voltage for LCD drive. In 1 / 2 bias mode, this is connected to $V_{DD1}$ .	OPEN

●Electrical characteristics (unless otherwise noted,  $T_a = 25^\circ\text{C}$ ,  $V_{DD} = 4.5\text{V}$  to  $5.5\text{V}$ ,  $V_{SS} = 0\text{V}$ )

Parameter	Symbol	Min.	Typ.	Max.	Unit	Conditions
Input high level voltage	$V_{IH}$	$0.8V_{DD}$	—	$V_{DD}$	V	CS, CK, DI, $\overline{RES}$
Input low level voltage	$V_{IL}$	0	—	$0.2V_{DD}$	V	CS, CK, DI, $\overline{RES}$
Input high level current	$I_{IH}$	0	—	6.0	$\mu\text{A}$	CS, CK, DI, $\overline{RES}$ , $V_i = V_{DD}$
Input low level current	$I_{IL}$	0	—	6.0	$\mu\text{A}$	CS, CK, DI, $\overline{RES}$ , $V_i = V_{SS}$
Output high level voltage	$V_{SOH}$	—	$V_{DD} - 1.0$	—	V	S1 ~ S32, $I_o = -20\mu\text{A}$
	$V_{COH}$	—	$V_{DD} - 1.0$	—	V	COM1 ~ COM3, $I_o = -100\mu\text{A}$
Output low level voltage	$V_{SOL}$	—	1.0	—	V	S1 ~ S32, $I_o = -20\mu\text{A}$
	$V_{COL}$	—	1.0	—	V	COM1 ~ COM3, $I_o = -100\mu\text{A}$
Intermediate output voltage	$V_{CM1}$	—	$1 / 2V_{DD} \pm 1.0$	—	V	COM1 ~ COM3, 1 / 2Bias
	$V_{SM1}$	—	$2 / 3V_{DD} \pm 1.0$	—	V	S1 ~ S32, 1 / 3Bias
	$V_{CM2}$	—	$2 / 3V_{DD} \pm 1.0$	—	V	COM1 ~ COM3, 1 / 3Bias
	$V_{SM2}$	—	$1 / 3V_{DD} \pm 1.0$	—	V	S1 ~ S32, 1 / 3Bias
	$V_{CM3}$	—	$1 / 3V_{DD} \pm 1.0$	—	V	COM1 ~ COM3, 1 / 3Bias
Power supply current	$I_o$	—	30	70	$\mu\text{A}$	Low-power mode
	$I_{DD}$	—	100	300	$\mu\text{A}$	$f_{osc} = 38\text{kHz}$

●Electrical characteristics

AC characteristics (unless otherwise noted,  $T_a = 25^\circ\text{C}$ ,  $V_{DD} = 4.5\text{V}$  to  $5.5\text{V}$ ,  $V_{SS} = 0\text{V}$ )

Parameter	Symbol	Pin	Min.	Typ.	Max.	Unit
Recommended external resistance	R	OSC	—	47	—	$\text{k}\Omega$
Recommended external capacitance	C	OSC	—	1000	—	$\mu\text{F}$
Guaranteed oscillation range	$f_{\text{osc}}$	OSC	19	38	76	$\text{kHz}$
Data setup time	$t_{\text{ds}}$	CK, DI	100	—	—	ns
Data hold time	$t_{\text{dH}}$	CK, DI	100	—	—	ns
CS setup time	$t_{\text{cs}}$	CS, CK	100	—	—	ns
CS hold time	$t_{\text{ch}}$	CS, CK	100	—	—	ns
CK "H" pulse width	$t_{\text{ckH}}$	CK	100	—	—	ns
CK "L" pulse width	$t_{\text{ckL}}$	CK	100	—	—	ns
Rise time	$t_{\text{r}}$	CS, CK, DI	—	—	300	ns
Fall time	$t_{\text{f}}$	CS, CK, DI	—	—	300	ns

AC timing waveform

(1) When CK is stopped at "L"

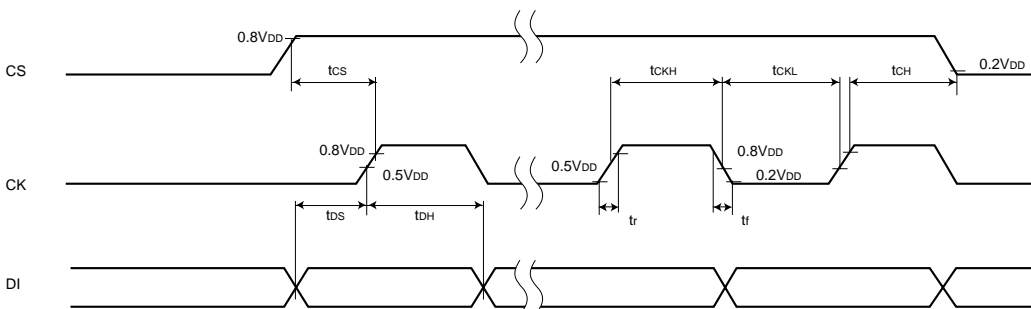

(2) When CK is stopped at "H"

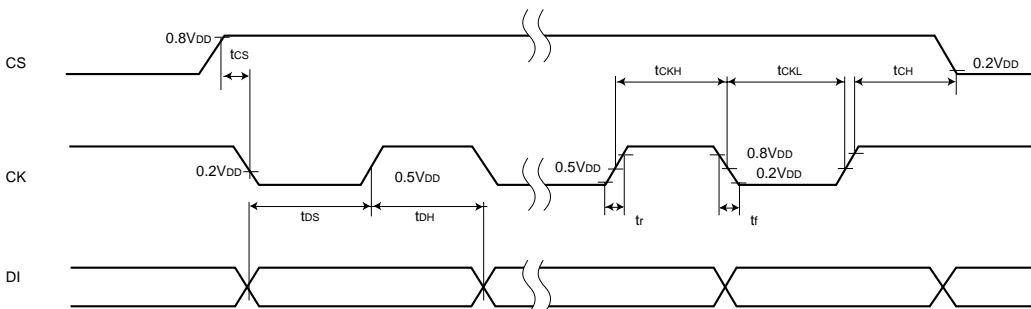

● Measurement circuit

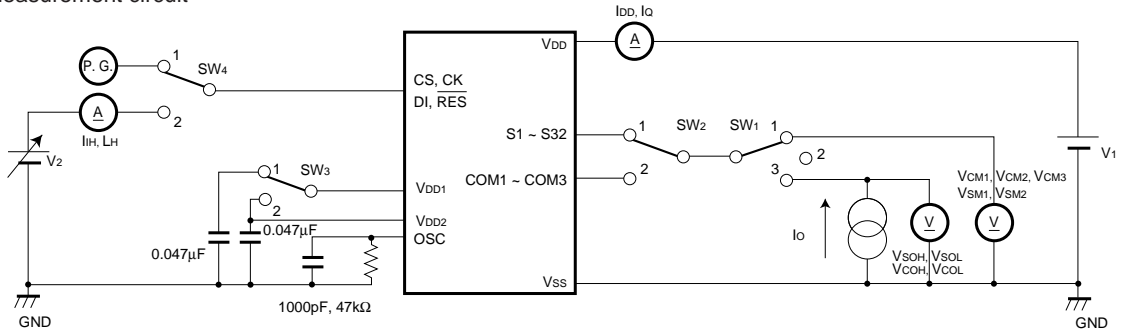

\* P. G.: Control signal generator for programmable signal generator, etc.

Fig.1

Measurement conditions

Parameter	Symbol	SW1	SW2	SW3	SW4	Conditions
Input high level voltage	$V_{IH}$	2	—	—	1	Set as P.G. input voltage; mode switching test
Input low level voltage	$V_{IL}$					
Input high level current	$I_{IH}$	2	—	—	2	$V_2 = V_{DD}$
Input low level current	$I_{IL}$					$V_2 = V_{SS}$
Output high level voltage	$V_{SOH}$	3	1	1	1	Pattern 1, $I_o = -20\mu A$
	$V_{COH}$		2			Pattern 1, $I_o = -100\mu A$
Output low level voltage	$V_{SOL}$	3	1	2	1	Pattern 2, $I_o = 20\mu A$
	$V_{COL}$		2			Pattern 2, $I_o = 100\mu A$
Intermediate output voltage	$V_{CM1}$	1	2	2	1	Pattern 3
	$V_{SM1}$		1			Pattern 4
	$V_{CM2}$		2	1		Pattern 4
	$V_{SM2}$		1			Pattern 5
	$V_{CM3}$		2			Pattern 5
Current dissipation	$I_Q$	2	—	—	1	Pattern 6
	$I_{DD}$					Test after power on
AC characteristics		2	—	—	1	Used as P.G. input condition

Measurement pattern

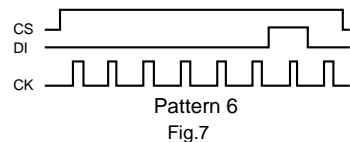
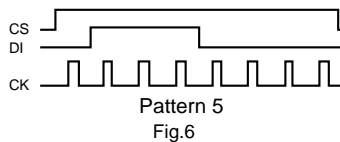
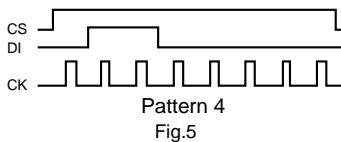
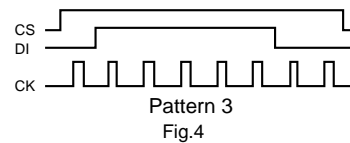
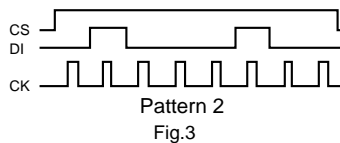
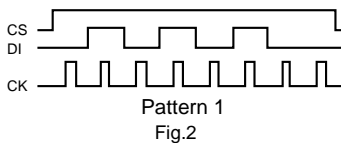

●Circuit operation

Timing charts

(1) When CK is stopped at “L”

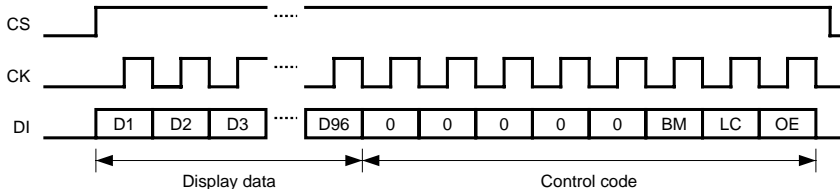

Fig.8

When CS is HIGH, data can be transferred. Data is sent to the shift register at the rising edge of CK. After all of the DI data has been transferred, CS should be

set to LOW. The voltage corresponding to the display data transferred at the falling edge of CS is output.

(2) When CK is stopped at “H”

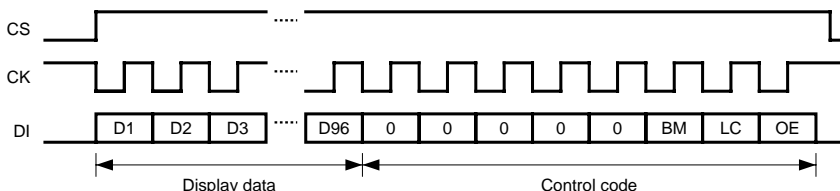

Fig.9

Control code table

OE	Output enable control
0	Normal operation
1	All display data is 0; no display (internal oscillation circuit is operating)

BM	Bias mode control
0	1 / 3 bias
1	1 / 2 bias

LC	Low power mode control
0	Normal operation
1	Low power mode = The internal oscillation circuit stops oscillating, and segment and common output = 0

Correspondence between display data input and segments

Segment	COM3	COM2	COM1
S1	D1	D2	D3
S2	D4	D5	D6
S3	D7	D8	D9
S4	D10	D11	D12
S5	D13	D14	D15
S6	D16	D17	D18
S7	D19	D20	D21
S8	D22	D23	D24
S9	D25	D26	D27
S10	D28	D29	D30
S11	D31	D32	D33
S12	D34	D35	D36
S13	D37	D38	D39
S14	D40	D41	D42
S15	D43	D44	D45
S16	D46	D47	D48

Segment	COM3	COM2	COM1
S17	D49	D50	D51
S18	D52	D53	D54
S19	D55	D56	D57
S20	D58	D59	D60
S21	D61	D62	D63
S22	D64	D65	D66
S23	D67	D68	D69
S24	D70	D71	D72
S25	D73	D74	D75
S26	D76	D77	D78
S27	D79	D80	D81
S28	D82	D83	D84
S29	D85	D86	D87
S30	D88	D89	D90
S31	D91	D92	D93
S32	D94	D95	D96

●Timing chart

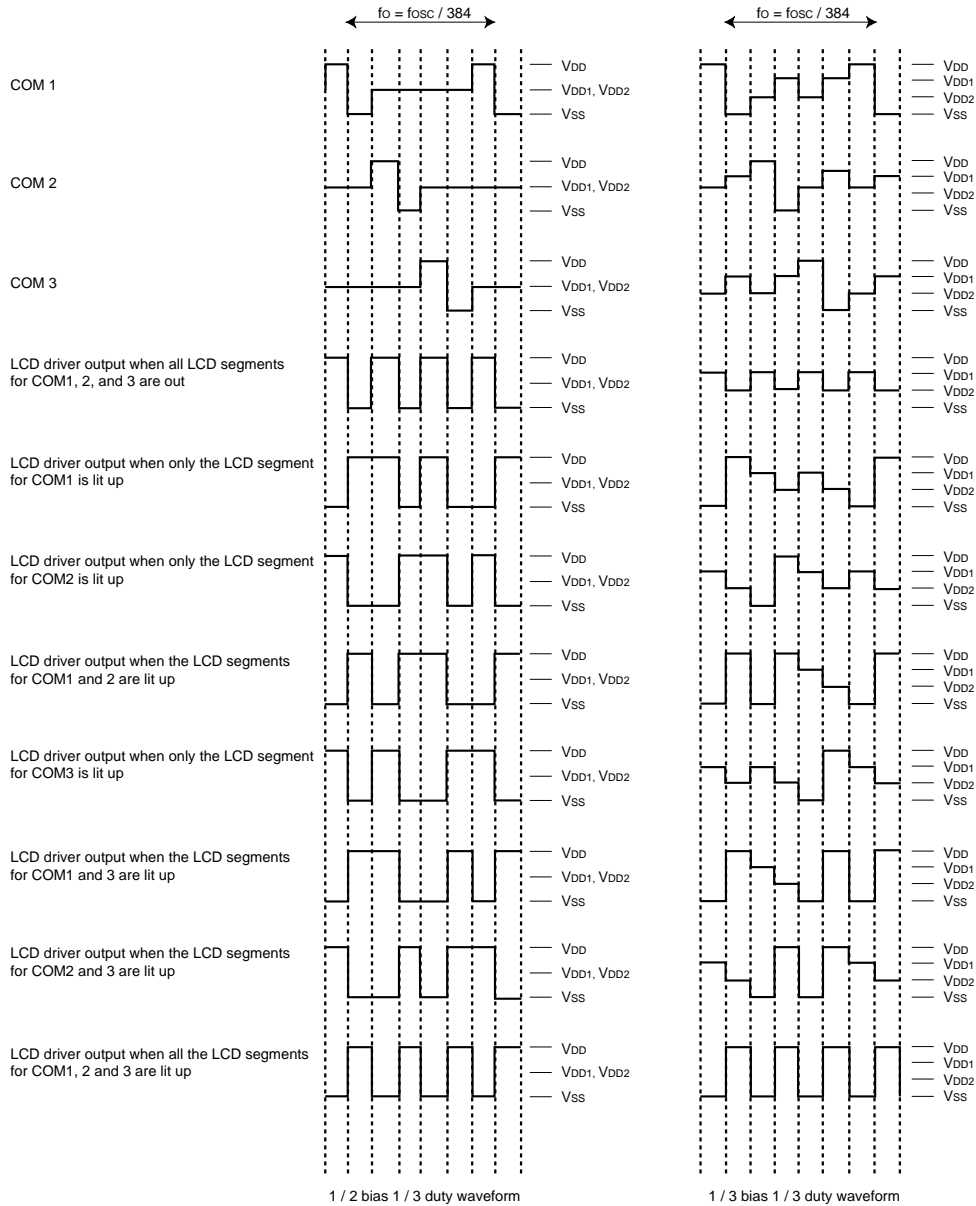
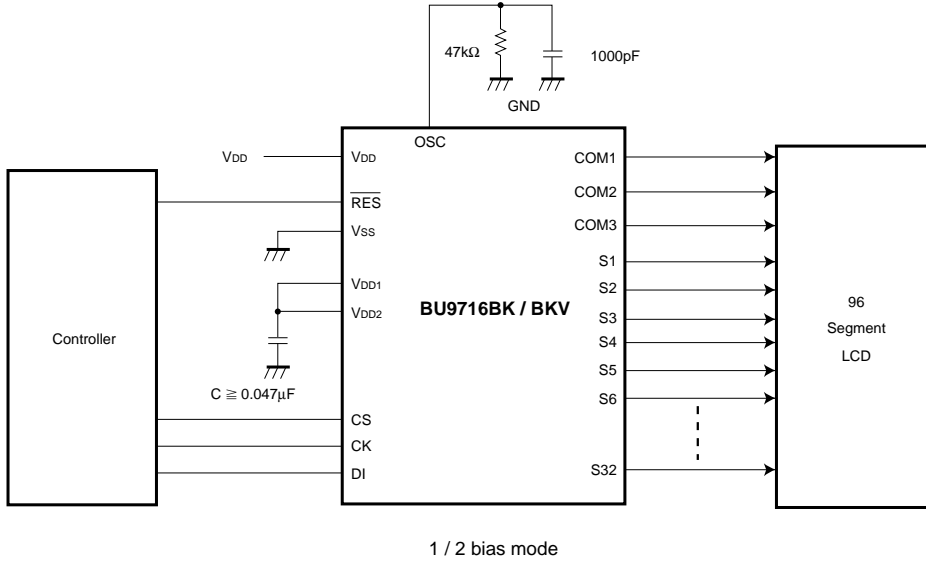

Fig.10

●Application example 1



1 / 2 bias mode

Fig.11

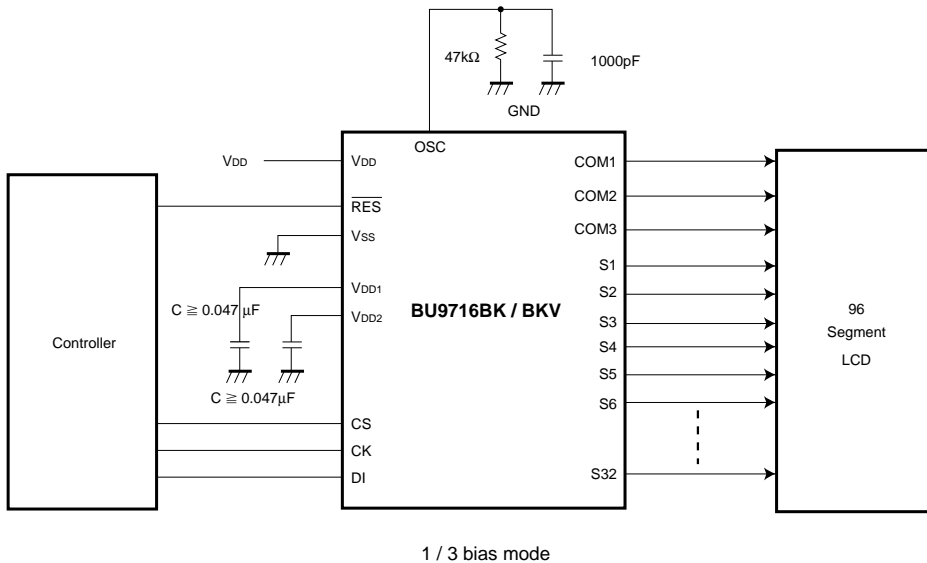

1 / 3 bias mode

Fig.12

●Application example 2

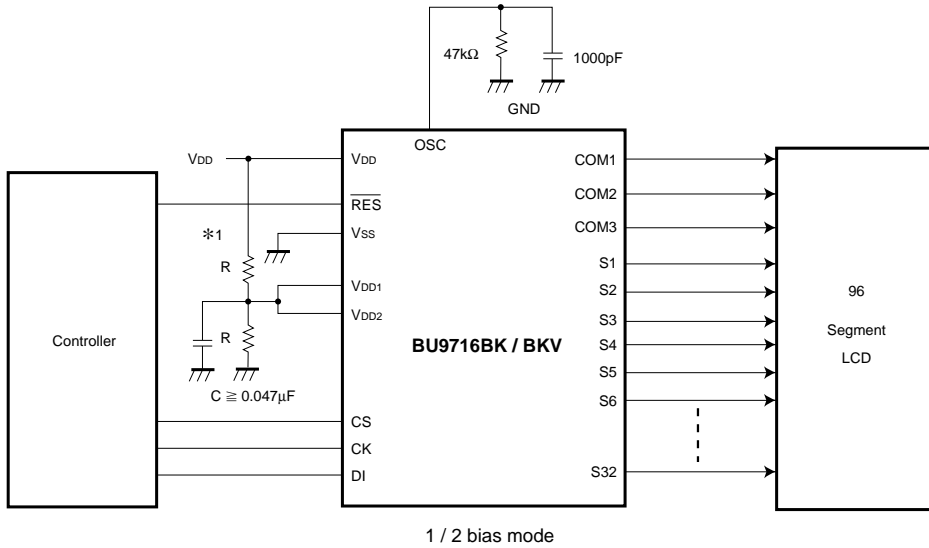

Fig.13

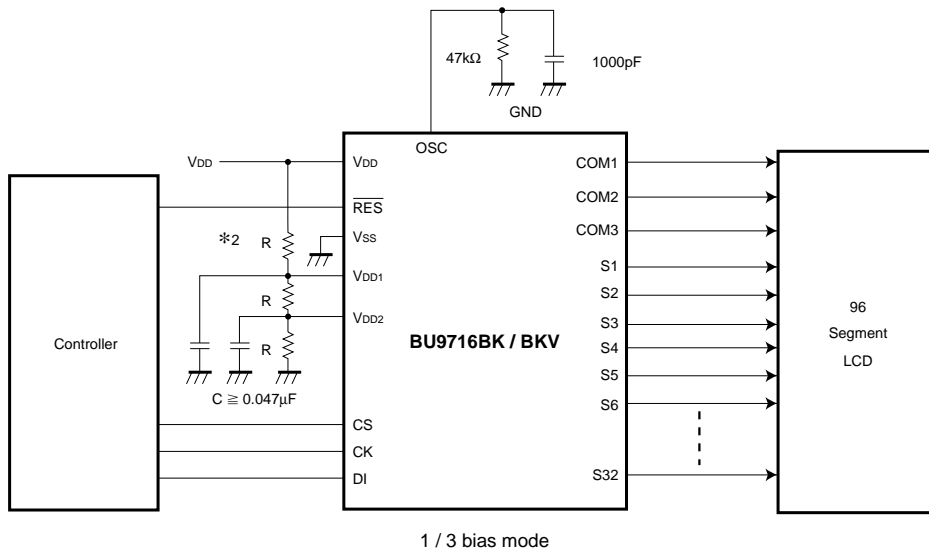
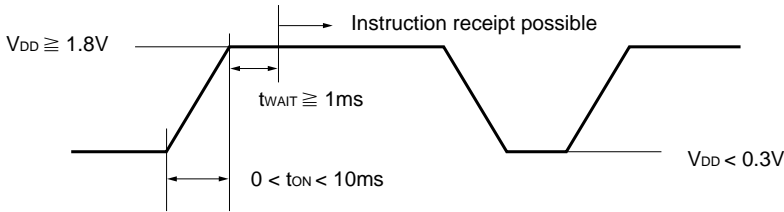

Fig. 14

The resistance values and capacitance for\*1 and \*2 should be set to match the LCD panel, and should be checked using test operation.

Make sure of the following when resetting when the power is on.

- When using the external reset terminal, make  $\overline{\text{RST}} = \text{“L”}$  at 1 ms or more with  $V_{\text{DD}}$  at 1.8V or more.
- When not using the external reset terminal,  $V_{\text{DD}}$  has to satisfy the following conditions.



●External dimensions (Units: mm)

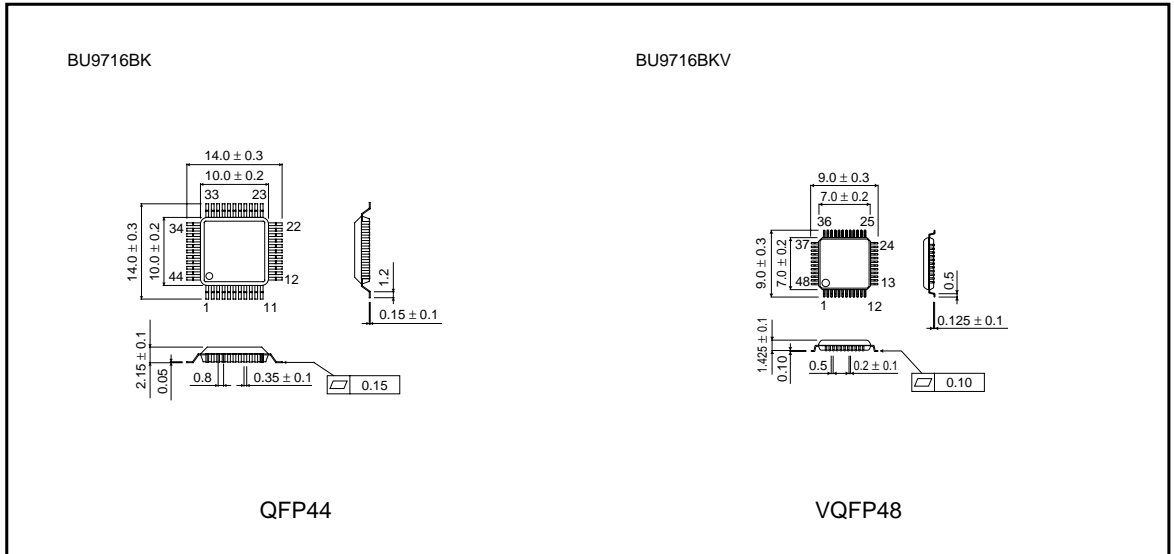

### Notes

- No technical content pages of this document may be reproduced in any form or transmitted by any means without prior permission of ROHM CO.,LTD.
- The contents described herein are subject to change without notice. The specifications for the product described in this document are for reference only. Upon actual use, therefore, please request that specifications to be separately delivered.
- Application circuit diagrams and circuit constants contained herein are shown as examples of standard use and operation. Please pay careful attention to the peripheral conditions when designing circuits and deciding upon circuit constants in the set.
- Any data, including, but not limited to application circuit diagrams information, described herein are intended only as illustrations of such devices and not as the specifications for such devices. ROHM CO.,LTD. disclaims any warranty that any use of such devices shall be free from infringement of any third party's intellectual property rights or other proprietary rights, and further, assumes no liability of whatsoever nature in the event of any such infringement, or arising from or connected with or related to the use of such devices.
- Upon the sale of any such devices, other than for buyer's right to use such devices itself, resell or otherwise dispose of the same, no express or implied right or license to practice or commercially exploit any intellectual property rights or other proprietary rights owned or controlled by
- ROHM CO., LTD. is granted to any such buyer.
- Products listed in this document use silicon as a basic material.  
Products listed in this document are no antiradiation design.

The products listed in this document are designed to be used with ordinary electronic equipment or devices (such as audio visual equipment, office-automation equipment, communications devices, electrical appliances and electronic toys).

Should you intend to use these products with equipment or devices which require an extremely high level of reliability and the malfunction of which would directly endanger human life (such as medical instruments, transportation equipment, aerospace machinery, nuclear-reactor controllers, fuel controllers and other safety devices), please be sure to consult with our sales representative in advance.



#### About Export Control Order in Japan

Products described herein are the objects of controlled goods in Annex 1 (Item 16) of Export Trade Control Order in Japan.

In case of export from Japan, please confirm if it applies to "objective" criteria or an "informed" (by MITI clause) on the basis of "catch all controls for Non-Proliferation of Weapons of Mass Destruction.

## Looking for pricing, stock, or lifecycle information?

Click below to explore more details on WIN SOURCE:

-  [View BU9716BK on WIN SOURCE](#)
-  [Rohm Semiconductor Information](#)

## Optimize Your Supply Chain with WIN SOURCE Solutions

-  Global Sourcing Solution
-  Obsolete Management
-  Cost Control Management
-  Shortage Management
-  Alternative Solution
-  Excess Inventory Management