



**THE DATASHEET OF
IRG7PH35UD1MPBF**



INSULATED GATE BIPOLAR TRANSISTOR WITH ULTRA-LOW V_F DIODE FOR INDUCTION HEATING AND SOFT SWITCHING APPLICATIONS

Features

- Low V_{CE(ON)} trench IGBT Technology
- Low Switching Losses
- Square RBSOA
- Ultra-Low V_F Diode
- 1300Vpk Repetitive Transient Capacity
- 100% of the Parts Tested for I_{LM}①
- Positive V_{CE(ON)} Temperature Co-Efficient
- Tight Parameter Distribution
- Lead Free Package

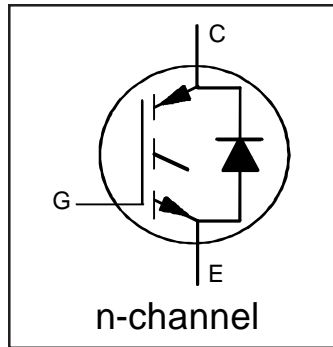

V_{CES} = 1200V
 I_C = 25A, T_C = 100°C
 T_{J(max)} = 150°C
 V_{CE(on)} typ. = 1.9V @ I_C = 20A

Benefits

- Device optimized for induction heating and soft switching applications
- High Efficiency due to Low V_{CE(on)}, low switching losses and Ultra-low V_F
- Rugged transient performance for increased reliability
- Excellent current sharing in parallel operation
- Low EMI

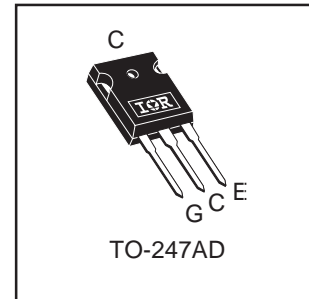

G	C	E
Gate	Collector	Emitter

Base part number	Package Type	Standard Pack		Orderable part number
		Form	Quantity	
IRG7PH35UD1MPbF	TO-247AD	Tube	25	IRG7PH35UD1MPbF

Absolute Maximum Ratings

Parameter	Parameter	Max.	Units
V _{CES}	Collector-to-Emitter Voltage	1200	V
V _{(BR)Transient}	Repetitive Transient Collector-to-Emitter Voltage ⑥	1300	
I _C @ T _C = 25°C	Continuous Collector Current	50	A
I _C @ T _C = 100°C	Continuous Collector Current	25	
I _{CM}	Pulse Collector Current, V _{GE} =15V ② ③	150	
I _{LM}	Clamped Inductive Load Current, V _{GE} =20V ①	80	
I _F @ T _C = 25°C	Diode Continuous Forward Current	50	
I _F @ T _C = 100°C	Diode Continuous Forward Current	25	
I _{FM}	Diode Maximum Forward Current ②	80	
V _{GE}	Continuous Gate-to-Emitter Voltage	±30	V
P _D @ T _C = 25°C	Maximum Power Dissipation	179	W
P _D @ T _C = 100°C	Maximum Power Dissipation	71	
T _J	Operating Junction and Storage Temperature Range	-55 to +150	°C
T _{STG}			
	Mounting Torque, 6-32 or M3 Screw	10 lbf-in (1.1 N-m)	

Thermal Resistance

Parameter	Parameter	Min.	Typ.	Max.	Units
R _{θJC} (IGBT)	Thermal Resistance Junction-to-Case-(each IGBT)④	—	—	0.70	°C/W
R _{θJC} (Diode)	Thermal Resistance Junction-to-Case-(each Diode) ④	—	—	1.35	
R _{θCS}	Thermal Resistance, Case-to-Sink (flat, greased surface)	—	0.24	—	
R _{θJA}	Thermal Resistance, Junction-to-Ambient (typical socket mount)	—	40	—	

Electrical Characteristics @ T_J = 25°C (unless otherwise specified)

	Parameter	Min.	Typ.	Max.	Units	Conditions
V _{(BR)CES}	Collector-to-Emitter Breakdown Voltage	1200	—	—	V	V _{GE} = 0V, I _C = 100μA ③
ΔV _{(BR)CES} /ΔT _J	Temperature Coeff. of Breakdown Voltage	—	1.2	—	V/°C	V _{GE} = 0V, I _C = 1mA (25°C-150°C)
V _{CE(on)}	Collector-to-Emitter Saturation Voltage	—	1.9	2.2	V	I _C = 20A, V _{GE} = 15V, T _J = 25°C
		—	2.3	—		I _C = 20A, V _{GE} = 15V, T _J = 150°C
V _{GE(th)}	Gate Threshold Voltage	3.0	—	6.0	V	V _{CE} = V _{GE} , I _C = 600μA
g _{fe}	Forward Transconductance	—	22	—	S	V _{CE} = 50V, I _C = 20A, PW = 30μs
I _{CES}	Collector-to-Emitter Leakage Current	—	1.0	100	μA	V _{GE} = 0V, V _{CE} = 1200V
		—	120	—		V _{GE} = 0V, V _{CE} = 1200V, T _J = 150°C
V _{FM}	Diode Forward Voltage Drop	—	1.15	1.26	V	I _F = 20A
		—	1.08	—		I _F = 20A, T _J = 150°C
I _{GES}	Gate-to-Emitter Leakage Current	—	—	±100	nA	V _{GE} = ±30V

Switching Characteristics @ T_J = 25°C (unless otherwise specified)

	Parameter	Min.	Typ.	Max.	Units	Conditions
Q _g	Total Gate Charge (turn-on)	—	85	130	nC	I _C = 20A V _{GE} = 15V V _{CC} = 600V
Q _{ge}	Gate-to-Emitter Charge (turn-on)	—	15	20		
Q _{gc}	Gate-to-Collector Charge (turn-on)	—	35	50		
E _{off}	Turn-Off Switching Loss	—	620	850	μJ	I _C = 20A, V _{CC} = 600V, V _{GE} = 15V R _G = 10Ω, L = 200μH, L _S = 150nH, T _J = 25°C Energy losses include tail
t _{d(off)}	Turn-Off delay time	—	160	180	ns	I _C = 20A, V _{CC} = 600V, V _{GE} = 15V R _G = 10Ω, L = 200μH, L _S = 150nH, T _J = 25°C
t _f	Fall time	—	80	105		
E _{off}	Turn-Off Switching Loss	—	1120	—	μJ	I _C = 20A, V _{CC} = 600V, V _{GE} = 15V R _G = 10Ω, L = 200μH, L _S = 150nH, T _J = 150°C Energy losses include tail
t _{d(off)}	Turn-Off delay time	—	190	—	ns	I _C = 20A, V _{CC} = 600V, V _{GE} = 15V R _G = 10Ω, L = 200μH, L _S = 150nH, T _J = 150°C
t _f	Fall time	—	210	—		
C _{ies}	Input Capacitance	—	1940	—	pF	V _{GE} = 0V V _{CC} = 30V f = 1.0Mhz
C _{oes}	Output Capacitance	—	120	—		
C _{res}	Reverse Transfer Capacitance	—	40	—		
RBSOA	Reverse Bias Safe Operating Area	FULL SQUARE				T _J = 150°C, I _C = 80A V _{CC} = 960V, V _p = 1200V R _G = 10Ω, V _{GE} = +20V to 0V

Notes:

- ① V_{CC} = 80% (V_{CES}), V_{GE} = 20V, R_G = 10Ω.
- ② Pulse width limited by max. junction temperature.
- ③ Refer to AN-1086 for guidelines for measuring V_{(BR)CES} safely.
- ④ R_θ is measured at T_J approximately 90°C.
- ⑤ FBSOA operating conditions only.
- ⑥ V_{GE} = 0V, T_J = 75°C, PW ≤ 10μs.

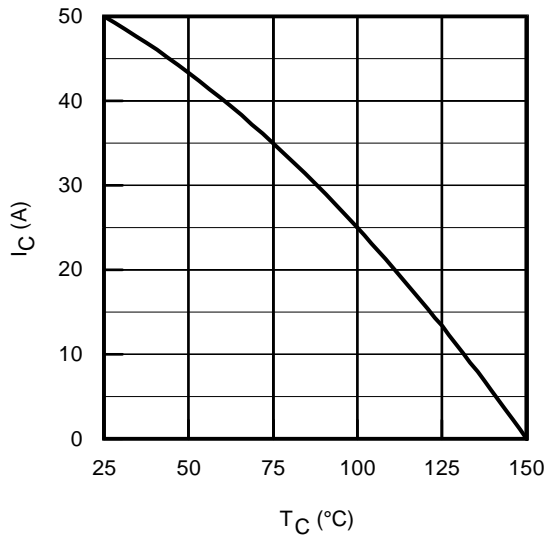

Fig. 1 - Maximum DC Collector Current vs. Case Temperature

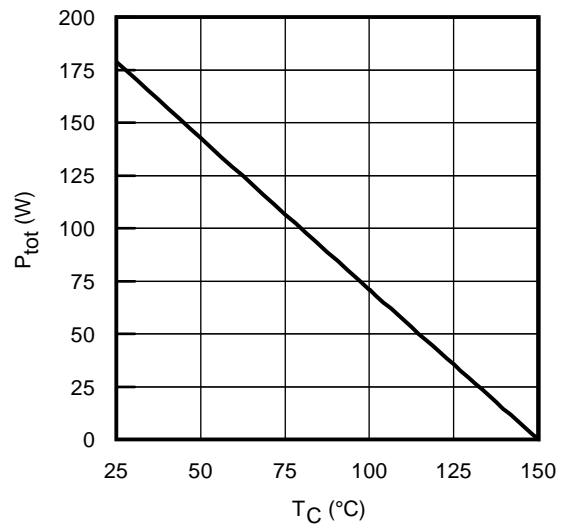

Fig. 2 - Power Dissipation vs. Case Temperature

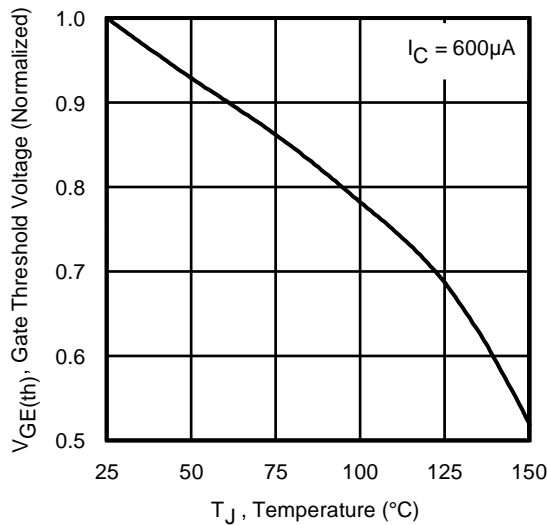

Fig. 3 - Typical Gate Threshold Voltage (Normalized) vs. Junction Temperature

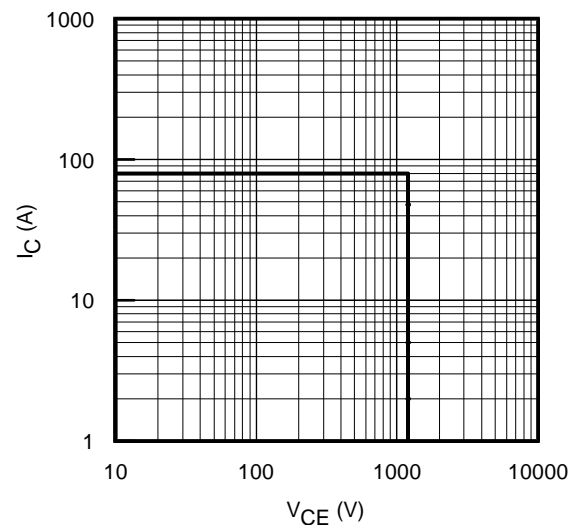

Fig. 4 - Reverse Bias SOA
 $T_J = 150^\circ\text{C}$; $V_{GE} = 20\text{V}$

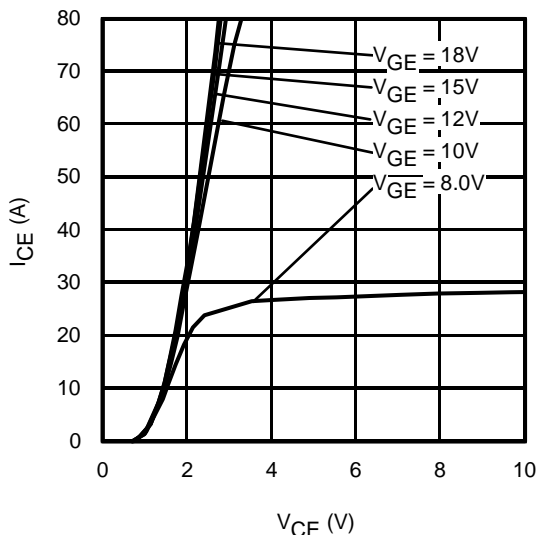

Fig. 5 - Typ. IGBT Output Characteristics
 $T_J = -40^\circ\text{C}$; $t_p = 30\mu\text{s}$

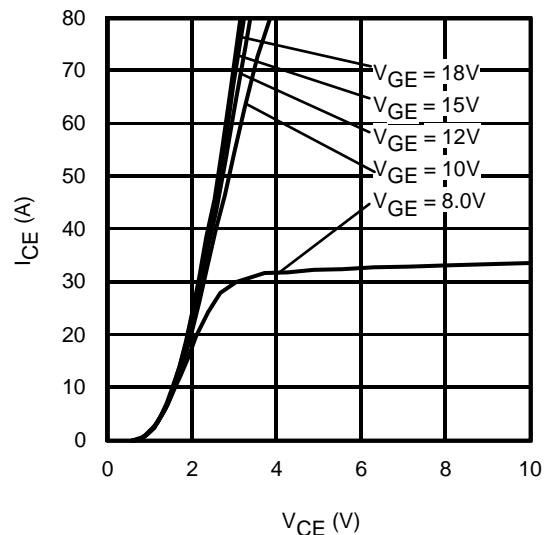

Fig. 6 - Typ. IGBT Output Characteristics
 $T_J = 25^\circ\text{C}$; $t_p = 30\mu\text{s}$

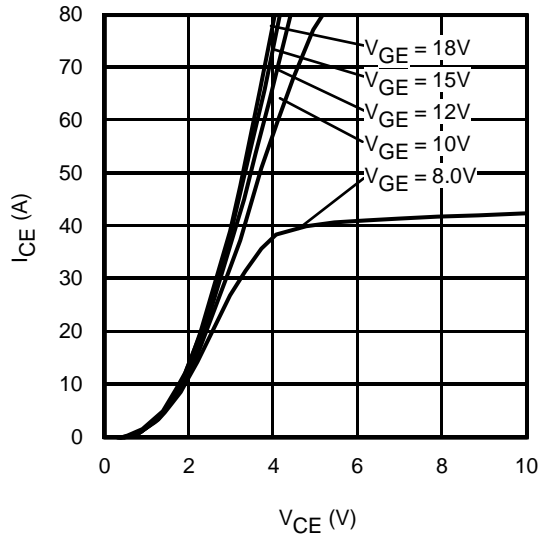

Fig. 7 - Typ. IGBT Output Characteristics
 $T_J = 150^\circ\text{C}$; $t_p = 30\mu\text{s}$

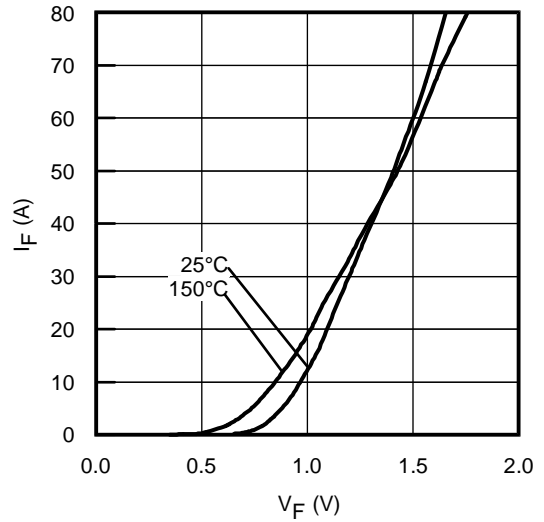

Fig. 8 - Typ. Diode Forward Voltage Drop Characteristics

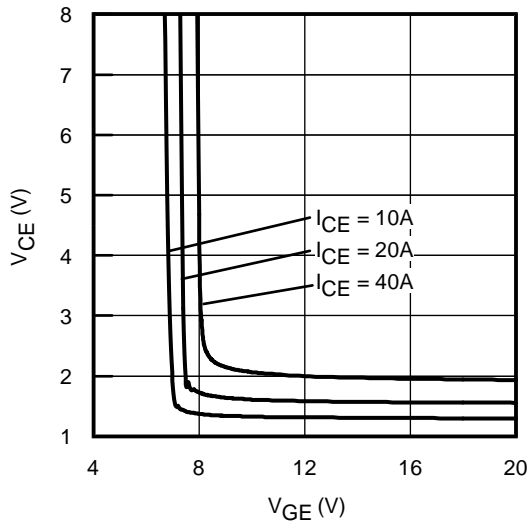

Fig. 9 - Typical V_{CE} vs. V_{GE}
 $T_J = -40^\circ\text{C}$

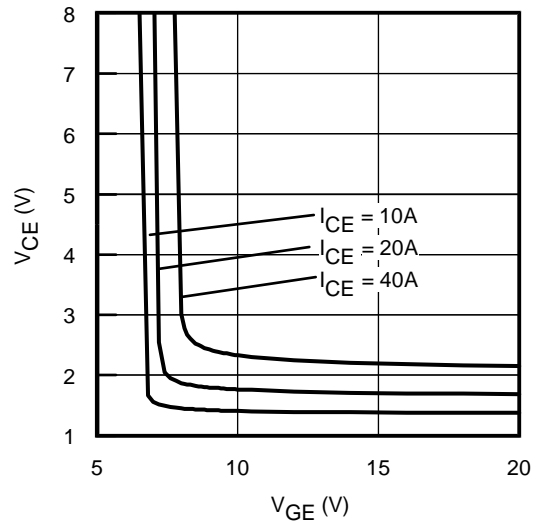

Fig. 10 - Typical V_{CE} vs. V_{GE}
 $T_J = 25^\circ\text{C}$

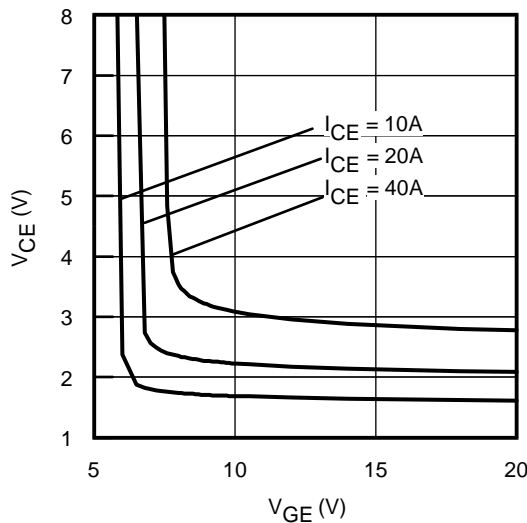

Fig. 11 - Typical V_{CE} vs. V_{GE}
 $T_J = 150^\circ\text{C}$

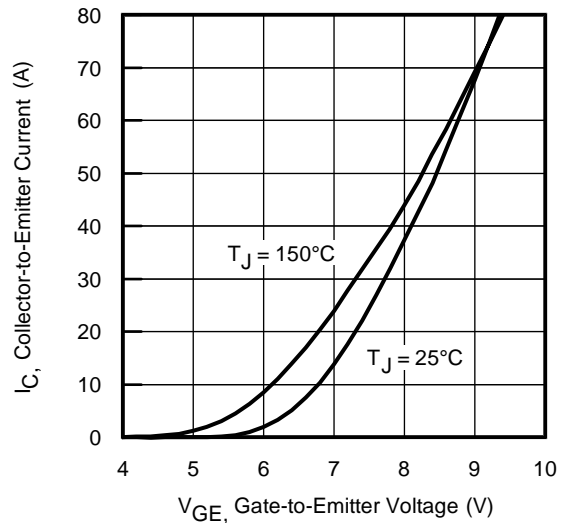

Fig. 12 - Typ. Transfer Characteristics
 $V_{CE} = 50\text{V}$; $t_p = 30\mu\text{s}$

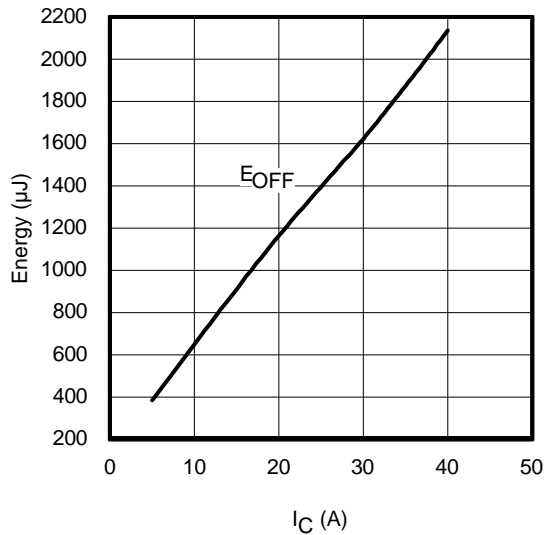

Fig. 13 - Typ. Energy Loss vs. I_C
 $T_J = 150^\circ\text{C}$; $L = 680\mu\text{H}$; $V_{CE} = 600\text{V}$, $R_G = 10\Omega$; $V_{GE} = 15\text{V}$

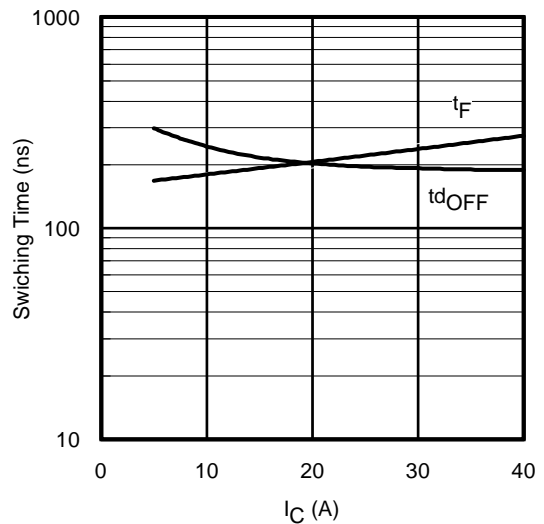

Fig. 14 - Typ. Switching Time vs. I_C
 $T_J = 150^\circ\text{C}$; $L = 680\mu\text{H}$; $V_{CE} = 600\text{V}$, $R_G = 10\Omega$; $V_{GE} = 15\text{V}$

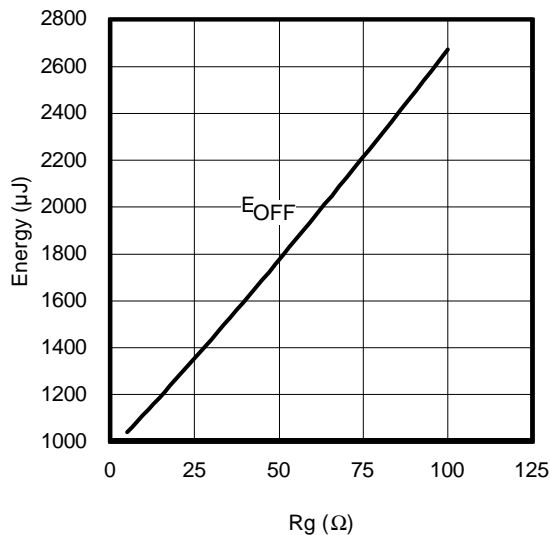

Fig. 15 - Typ. Energy Loss vs. R_G
 $T_J = 150^\circ\text{C}$; $L = 680\mu\text{H}$; $V_{CE} = 600\text{V}$, $I_{CE} = 20\text{A}$; $V_{GE} = 15\text{V}$

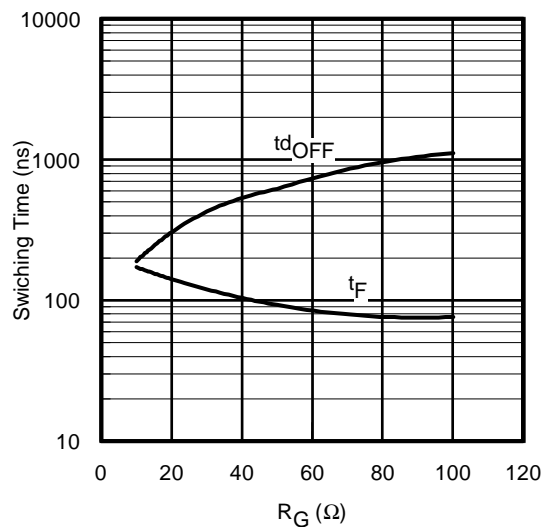

Fig. 16 - Typ. Switching Time vs. R_G
 $T_J = 150^\circ\text{C}$; $L = 680\mu\text{H}$; $V_{CE} = 600\text{V}$, $I_{CE} = 20\text{A}$; $V_{GE} = 15\text{V}$

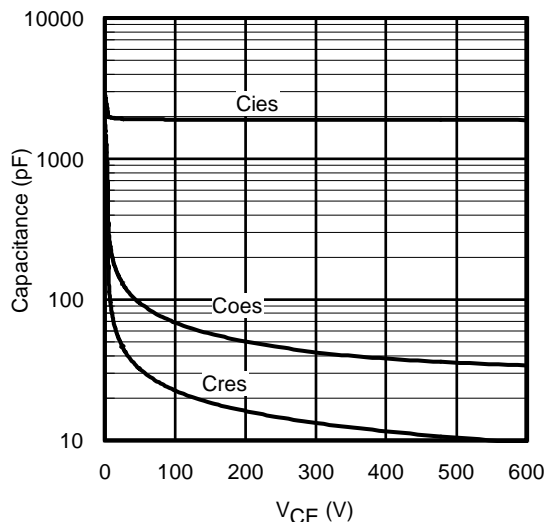

Fig. 17 - Typ. Capacitance vs. V_{CE}
 $V_{GE} = 0\text{V}$; $f = 1\text{MHz}$

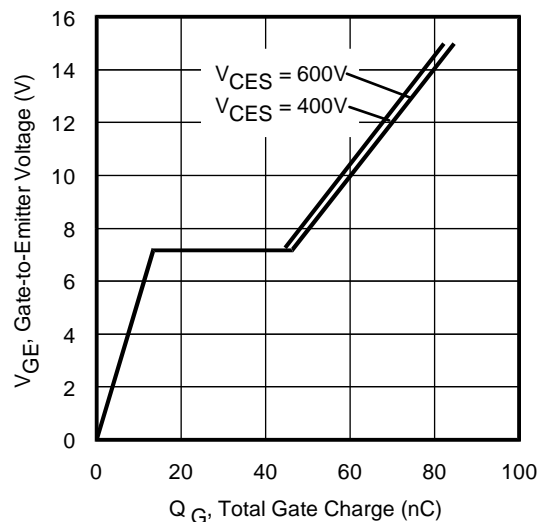
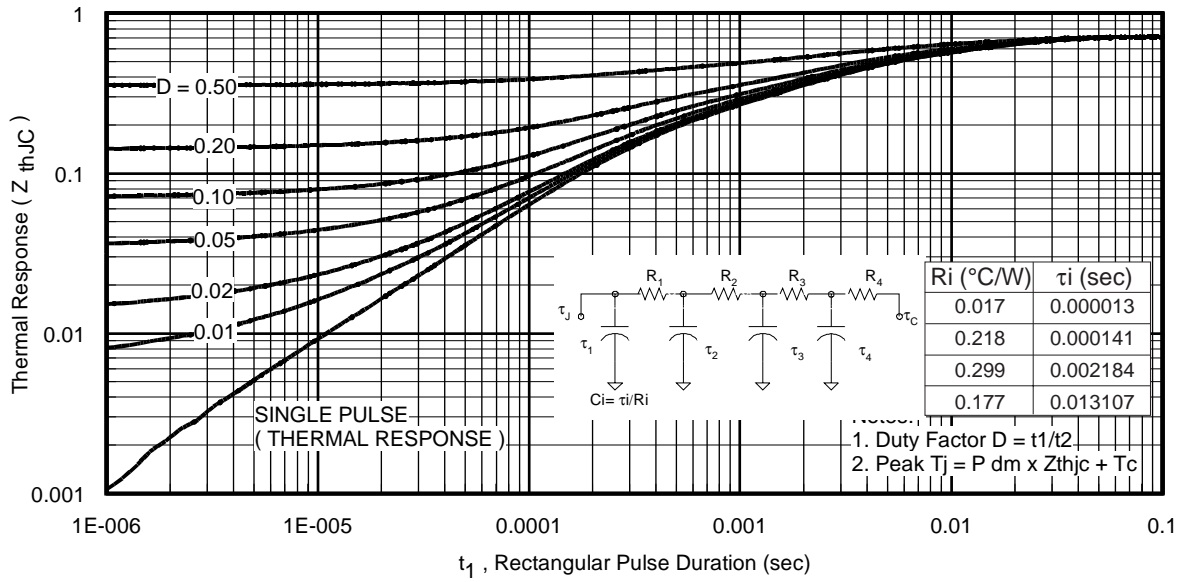
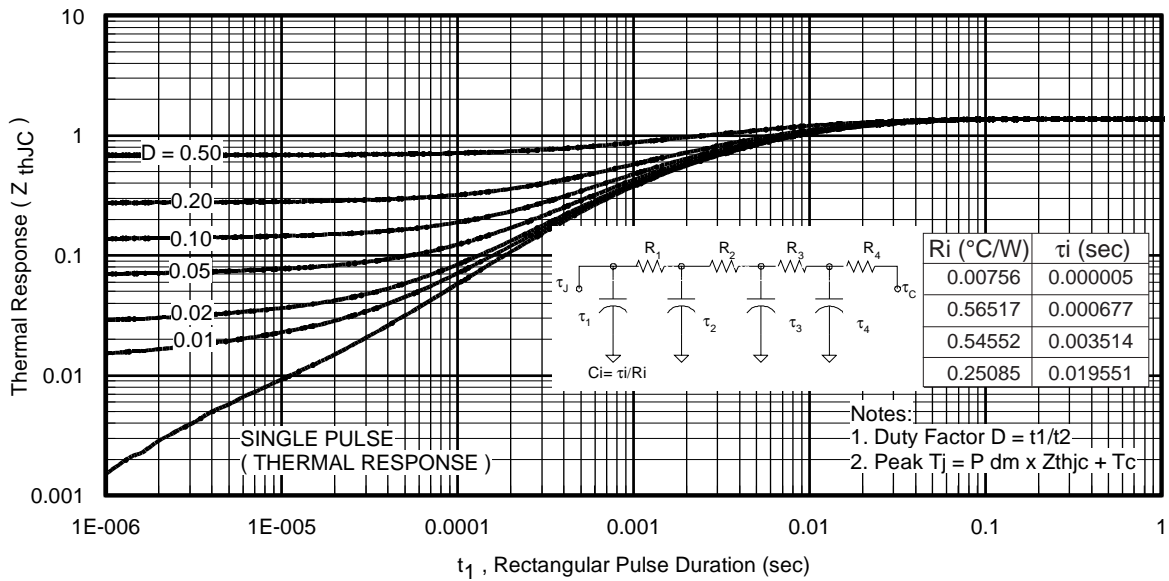

Fig. 18 - Typical Gate Charge vs. V_{GE}
 $I_{CE} = 20\text{A}$; $L = 2.4\text{mH}$

Fig 19. Maximum Transient Thermal Impedance, Junction-to-Case (IGBT)

Fig. 20. Maximum Transient Thermal Impedance, Junction-to-Case (DIODE)

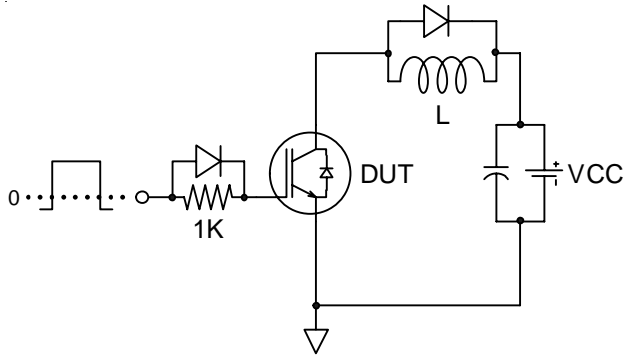

Fig.C.T.1 - Gate Charge Circuit (turn-off)

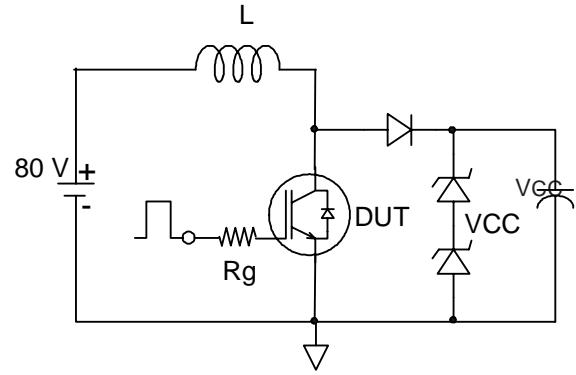

Fig.C.T.2 - RBSOA Circuit

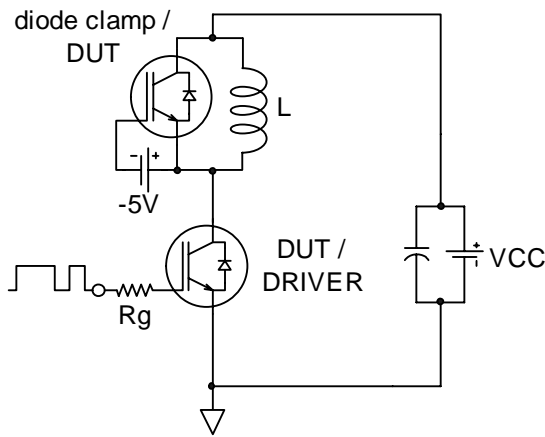

Fig.C.T.3 - Switching Loss Circuit

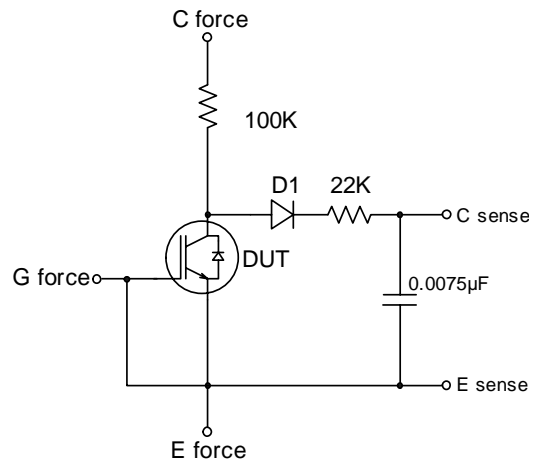

Fig.C.T.4 - BVCES Filter Circuit

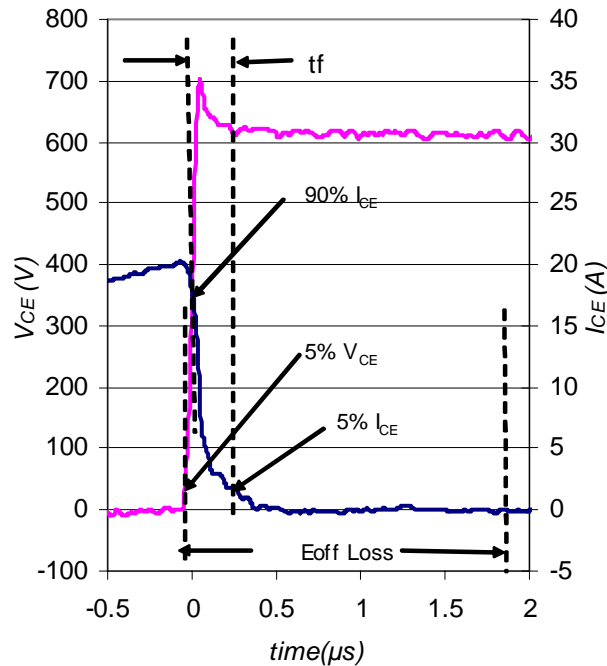
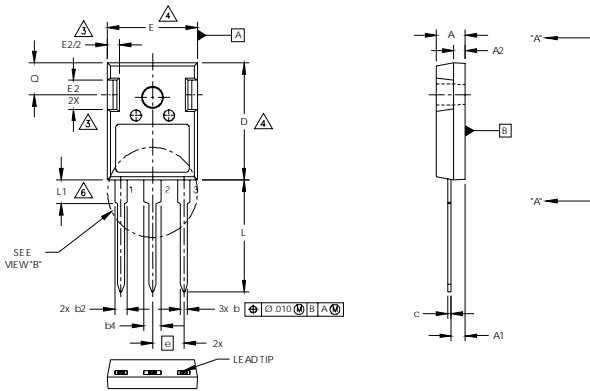

Fig. WF1 - Typ. Turn-off Loss Waveform
@ T_J = 150°C using Fig. CT.3

TO-247AD Package Outline

(Dimensions are shown in millimeters (inches))



SYMBOL	DIMENSIONS				NOTES
	INCHES		MILLIMETERS		
	MIN.	MAX.	MIN.	MAX.	
A	.190	.204	4.83	5.20	4 5 4
A1	.090	.100	2.29	2.54	
A2	.075	.085	1.91	2.16	
b	.042	.052	1.07	1.33	
b2	.075	.094	1.91	2.41	
b4	.113	.133	2.87	3.38	
c	.022	.026	0.55	0.68	
D	.819	.830	20.80	21.10	
D1	.640	.694	16.25	17.65	
E	.620	.635	15.75	16.13	
E1	.512	.570	13.00	14.50	
E2	.145	.196	3.68	5.00	
e	.215 Typical		5.45 Typical		
L	.780	.800	19.80	20.32	
L1	.161	.173	4.10	4.40	
φ P	.138	.143	3.51	3.65	
Q	.216	.236	5.49	6.00	
S	.238	.248	6.04	6.30	

LEAD ASSIGNMENTS

HEXFET

- 1.- GATE
- 2.- DRAIN
- 3.- SOURCE
- 4.- DRAIN

IGBTs, CoPACK

- 1.- GATE
- 2.- COLLECTOR
- 3.- EMITTER
- 4.- COLLECTOR

DIODES

- 1.- ANODE/OPEN
- 2.- CATHODE
- 3.- ANODE

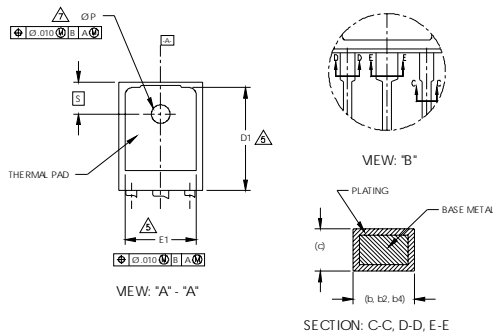

NOTES:

- 1 DIMENSIONING AND TOLERANCING AS PER ASME Y14.5M 1994.
- 2 DIMENSIONS ARE SHOWN IN INCHES AND MILLIMETERS.
- 3 CONTOUR OF SLOT OPTIONAL.
- 4 DIMENSION D & E DO NOT INCLUDE MOLD FLASH. MOLD FLASH SHALL NOT EXCEED .005" (0.127) PER SIDE. THESE DIMENSIONS ARE MEASURED AT THE OUTERMOST EXTREMES OF THE PLASTIC BODY.
- 5 THERMAL PAD CONTOUR OPTIONAL WITHIN DIMENSIONS D1 & E1.
- 6 LEAD FINISH UNCONTROLLED IN L1.
- 7 φ P TO HAVE A MAXIMUM DRAFT ANGLE OF 1.5 ° TO THE TOP OF THE PART WITH A MAXIMUM HOLE DIAMETER OF .154 INCH.

TO-247AD Part Marking Information

EXAMPLE: THIS IS AN IRFPE30 WITH ASSEMBLY LOT CODE 5657 ASSEMBLED ON WW 35, 2001 IN THE ASSEMBLY LINE "H"

Note: "P" in assembly line position indicates "Lead-Free"

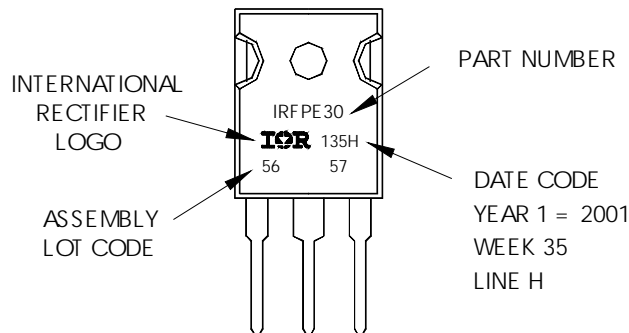

TO-247AD package is not recommended for Surface Mount Application.

Note: For the most current drawing please refer to IR website at <http://www.irf.com/package/>

Qualification information[†]

Qualification level	Industrial ^{††} (per JEDEC JE S D47F ^{†††} guidelines)	
Moisture Sensitivity Level	TO-247AD	N/A (per JEDEC J-STD-020D ^{†††})
RoHS compliant	Yes	

† Qualification standards can be found at International Rectifier’s web site

<http://www.irf.com/product-info/reliability>

†† Higher qualification ratings may be available should the user have such requirements.

Please contact your International Rectifier sales representative for further information:

<http://www.irf.com/whoto-call/salesrep/>

††† Applicable version of JEDEC standard at the time of product release.

Looking for pricing, stock, or lifecycle information?

Click below to explore more details on WIN SOURCE:

- ⊖ [View IRG7PH35UD1MPBF on WIN SOURCE](#)
- ⊖ [Infineon Technologies](#) Information

Optimize Your Supply Chain with WIN SOURCE Solutions

- ✓ Global Sourcing Solution
- ✓ Obsolete Management
- ✓ Cost Control Management
- ✓ Shortage Management
- ✓ Alternative Solution
- ✓ Excess Inventory Management