

LVDS Interface ICs

27bit LVDS Transmitter

BU90T81



● **General Description**

The BU90T81 transmitter operates from 20MHz to 112MHz wide clock range, and 27bits data of parallel LVCMOS level inputs(R/G/B24bits and VSYNC,HSYNC,DE) are converted to four channels of LVDS data stream. Data is transmitted seven times (7X) stream and reduce cable number by 3(1/3) or less.

The BU90T81 operates from a single 1.8V supply for low power. And the BU90T81 has low swing mode to be able to expect further low power and low EMI .

● **Features**

- 24bits data of parallel LVCMOS level inputs are converted to four channels of LVDS data stream.
- Support clock frequency from 20MHz up to 112MHz.
- Low power 1.8V CMOS design
- Power down mode
- Clock edge selectable
- Support 6bit/8bit mode selectable
- Support reduced swing LVDS for low EMI.
- Support LVDS Outputs pin reverse function
- Support spread spectrum clock generator input

● **Key Specifications**

- Supply Voltage range 1.65 to 1.95 V
- Operating frequency 20 to 112MHz
- Operating Temperature Range -20 to 85°C
- Power Consumption 50mW(Typ)

● **Packages**

VBGA048W040 4.00 mm × 4.00 mm × 0.90 mm

● **Applications**

- Tablet
- Netbook PC
- Digital Picture Frame

● **Block Diagram**

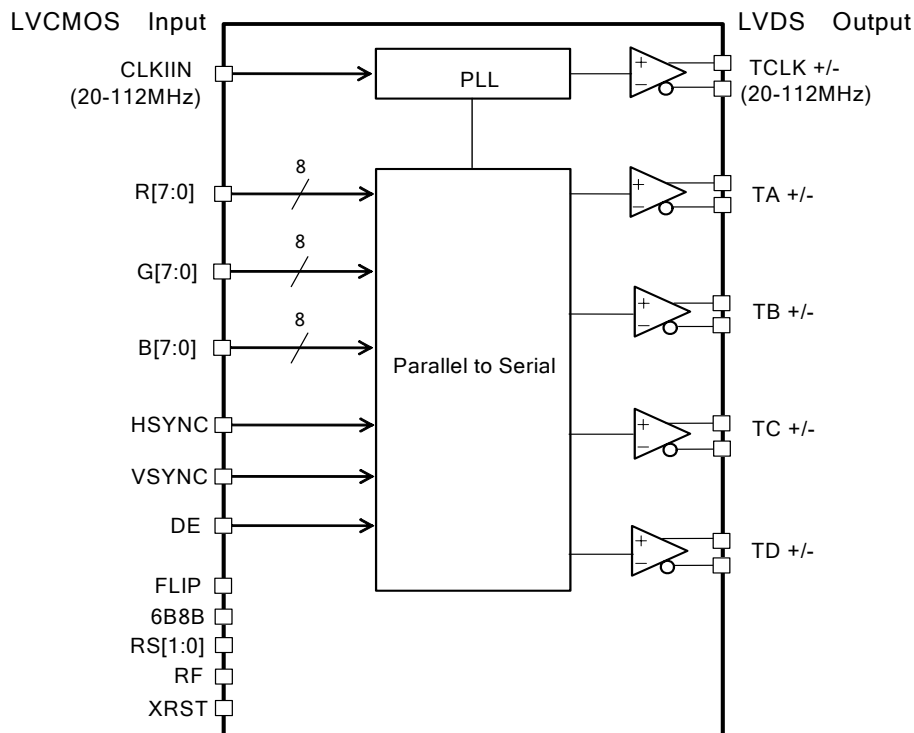

Figure-1 Block Diagram

○ Product structure : Silicon monolithic integrated circuit ○ This product is not designed protection against radioactive rays

● Pin Configuration

Top view

	1	2	3	4	5	6	7
A	G[5]	G[7]	R[1]	R[3]	R[5]	R[6]	R[7]
B	-	G[6]	R[0]	R[2]	R[4]	TA-	TA+
C	G[3]	G[4]	GND	RS[1]	RS[0]	TB-	TB+
D	G[1]	G[2]	RF	VDD	VDD	TC-	TC+
E	G[0]	B[7]	FLIP	6B8B	GND	TCLK-	TCLK+
F	B[6]	B[5]	B[2]	B[0]	DE	TD-	TD+
G	B[4]	B[3]	B[1]	HSYNC	VSYNC	CLKIN	XRST

48pin VBGA

Figure-2 Pin Diagram (Top View)

● Pin Description

Pin Name	Pin No.	Type	Descriptions		
TA+/-, TB+/-, TC+/-,TD+/-	B7,B6,C7,C6,D7,D6,F7,F6	LVDS OUT	LVDS Data out		
TCLK+/-	E7,6		LVDS Clock out		
R[7:0]	A7,A6,A5,B5,A4,B4,A3,B3	CMOS IN	Pixel and control data inputs		
G[7:0]	A2,B2,A1,C2,C1,D2,D1,E1				
B[7:0]	E2,F1,F2,G1,G2,F3,G3,F4				
HSYNC,VSYNC, DE	G4,G5,F5				
CLKIN	G6			Clock input	
XRST	G7	CMOS IN	Power Down H : Normal operation L : Power down (all LVDS output signal are Hi-z)		
RF	D3		Input CLK Triggering Edge Select. H : Rising edge L : Falling edge		
RS[1:0]	C3,C5		LVDS swing mode select		
			RS1	RS0	LVDS swing
			L	L	TYP=160mV
			L	H	TYP=200mV
			H	L	TYP=350mV
		H	H	Reserved	
6B8B	E4	6bit/8bit mode select H : 6bit mode(FLIP=L TD+/- is Hiz) (FLIP=H TA+/- is Hiz) L : 8bit mode			
FLIP	E3	LVDS output pin reverse select. H : Reverse L : Normal			
VDD	D4,D5	POWER	1.8V Power supply		
GND	C3,E5	GND	Ground Pins		

● Absolute Maximum Ratings

Parameter	Symbol	Rating		Units
		Min	Max	
Supply Voltage	V_{DD}	-0.3	2.5	V
Input Voltage	V_{IN}	-0.3	$V_{DD}+0.3$	V
Output Voltage	V_{OUT}	-0.3	$V_{DD}+0.3$	V
Storage Temperature Range	Tstg	-55	125	°C

● Operating Ratings

Parameter	Symbol	Rating			Units	Conditions
		Min	Typ	Max		
Supply Voltage	V_{DD}	1.65	1.8	1.95	V	
Operating Temperature Range	Topr	-20	-	85	°C	
Operating frequency	Fmax	20	-	112	MHz	

● Package Power

Package	Power Dissipation (mW)	Derating (mW/°C)*1
VBGA048W040	800*1	8.0*1

*1:Package power when mounting on the PCB board.

The size of PCB board : 114.3×76.2×1.6 (mm³)
 The material of PCB board : The FR4 glass epoxy board.

● DC characteristics

Table 1 : LVCMOS DC Specifications ($V_{DD}=1.65V\sim 1.95V$, $T_a=-20^{\circ}C\sim +85^{\circ}C$)

Symbol	Parameter	Rating			Units	Conditions
		Min	Typ	Max		
V_{IH}	High Level Input Voltage	$V_{DD}\times 0.7$	-	V_{DD}	V	
V_{IL}	Low Level Input Voltage	GND	-	$V_{DD}\times 0.3$	V	
I_{INC}	Input Current	-10	-	+10	μA	$0V\leq V_{IN}\leq V_{DD}$

Table2: LVDS Transmitter DC Specifications ($V_{DD}=1.65V\sim 1.95V$, $T_a=-20^{\circ}C\sim +85^{\circ}C$)

Symbol	Parameter	Rating			Units	Conditions
		Min	Typ	Max		
V_{OD}	Differential Output Voltage	250	350	450	mV	RL=100Ω RS[1:0]= HL RS[1:0]= LH RS[1:0]= LL
		130	200	270	mV	
		110	160	210	mV	
ΔV_{OD}	Change in VOD between complementary output states	-	-	35	mV	RL=100Ω
V_{oc}	Common Mode Voltage	1.125	1.25	1.375	V	
ΔV_{oc}	Change in VOC between complementary output states	-	-	35	mV	
I_{os}	Output Short Circuit Current	-90	-	-	mA	$V_{OUT}=0V$
I_{oz}	Output TRI-STATE Current	-10	-	+10	μA	XRST=0V, $V_{OUT}=0V$ to V_{DD}

● AC characteristics

Table 3 : Switching Characteristics (VDD=1.8V, Ta=25°C RL=100Ω CL=5pF RS[1:0]=HL)

Symbol	Parameter	Min	Typ	Max	Units
t _{TCP}	CLK OUT Period	8.93	-	50	ns
t _{TCIT}	CLK IN Transition time	-	-	5.0	ns
t _{TCH}	CLK IN High Time	0.35t _{TCP}	0.5t _{TCP}	0.65t _{TCP}	ns
t _{TCL}	CLK IN Low Time	0.35t _{TCP}	0.5t _{TCP}	0.65t _{TCP}	ns
t _{TS}	LVSMOS Data Set up to CLK IN	2.5	-	-	ns
t _{TH}	LVC MOS Data Hold from CLK IN	0	-	-	ns
t _{LVT}	LVDS Transition Time	-	0.6	1.5	ns
T _{TSUP}	Differential Output Set up Time	CLKOUT=112MHz	-	200	ps
T _{THLD}	Differential Output Hold time	CLKOUT=112MHz	-	200	ps
t _{TOP6}	Output Data Position 6	$2 \frac{t_{TCP}}{7} - T_{THLD}$	$2 \frac{t_{TCP}}{7}$	$2 \frac{t_{TCP}}{7} + T_{TSUP}$	ns
t _{TOP5}	Output Data Position 5	$3 \frac{t_{TCP}}{7} - T_{THLD}$	$3 \frac{t_{TCP}}{7}$	$3 \frac{t_{TCP}}{7} + T_{TSUP}$	ns
t _{TOP4}	Output Data Position 4	$4 \frac{t_{TCP}}{7} - T_{THLD}$	$4 \frac{t_{TCP}}{7}$	$4 \frac{t_{TCP}}{7} + T_{TSUP}$	ns
t _{TOP3}	Output Data Position 3	$5 \frac{t_{TCP}}{7} - T_{THLD}$	$5 \frac{t_{TCP}}{7}$	$5 \frac{t_{TCP}}{7} + T_{TSUP}$	ns
t _{TOP2}	Output Data Position 2	$6 \frac{t_{TCP}}{7} - T_{THLD}$	$6 \frac{t_{TCP}}{7}$	$6 \frac{t_{TCP}}{7} + T_{TSUP}$	ns
t _{TOP1}	Output Data Position 1	$7 \frac{t_{TCP}}{7} - T_{THLD}$	$7 \frac{t_{TCP}}{7}$	$7 \frac{t_{TCP}}{7} + T_{TSUP}$	ns
t _{TOP0}	Output Data Position 0	$8 \frac{t_{TCP}}{7} - T_{THLD}$	$8 \frac{t_{TCP}}{7}$	$8 \frac{t_{TCP}}{7} + T_{TSUP}$	ns
t _{TPLL}	Phase Locked Loop Set Time	-	-	10	ms

● AC Timing Diagrams

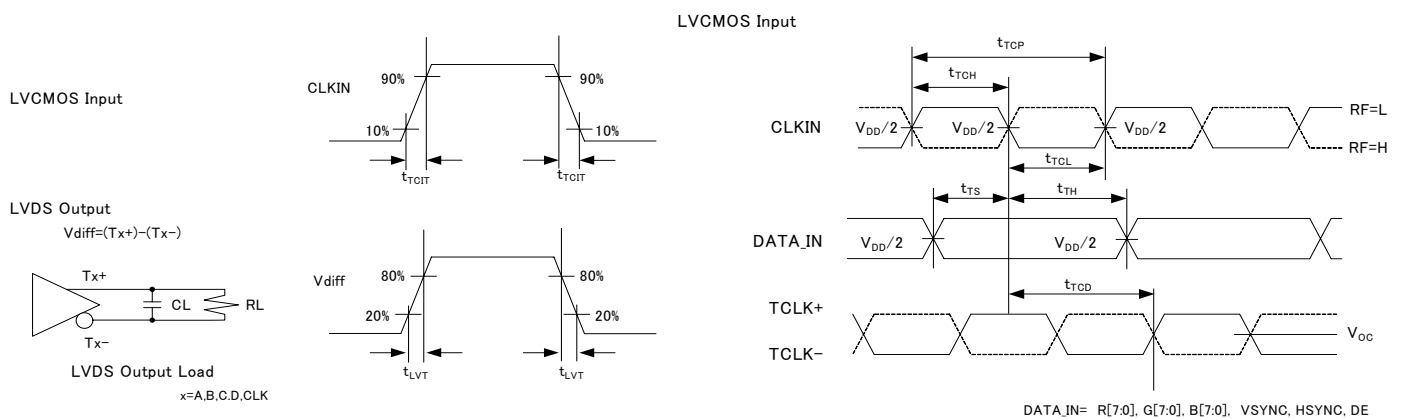

Figure-3 LVC MOS Input AC Timing Diagrams

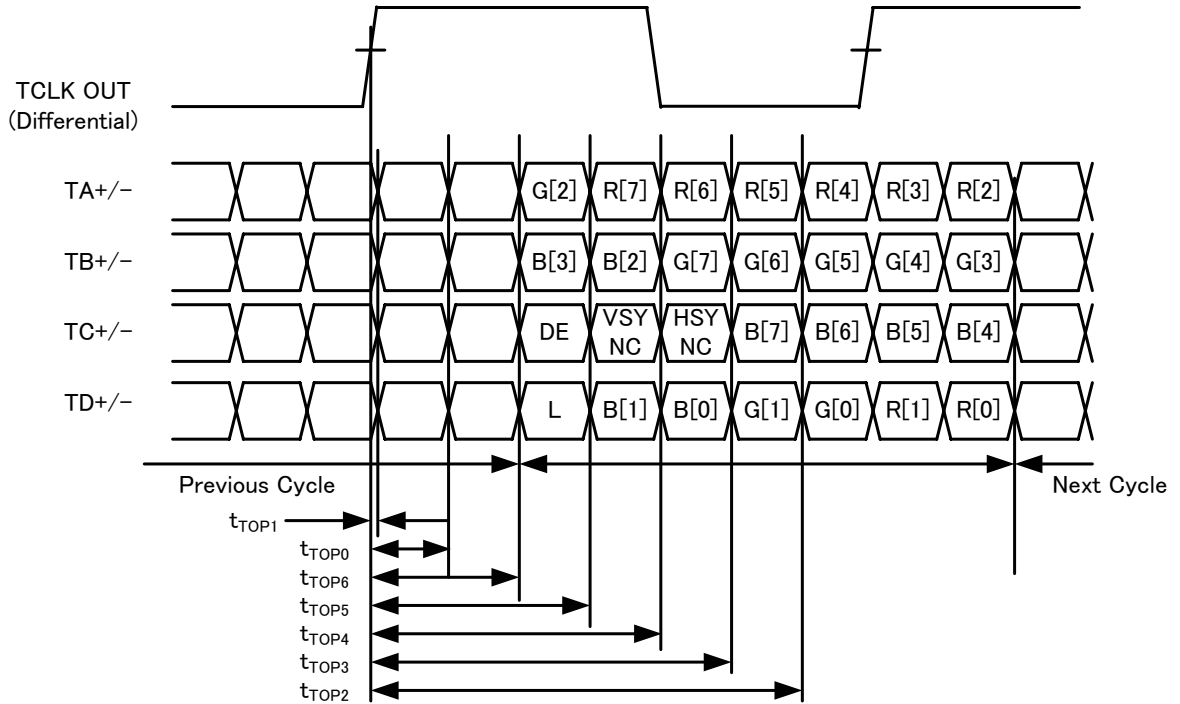

Figure-4 LVDS Output AC Timing Diagrams

● Phase Locked Loop Set Time

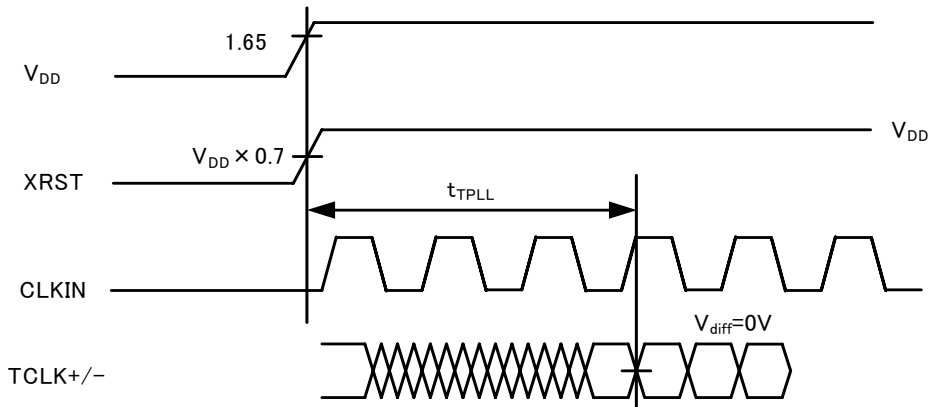

Figure-5 Phase Locked Loop Set Time

●Supply Current

Table 4: Supply Current (6B8B = L)

Symbol	Parameter	Rating			Units	Conditions	
		Min	Typ	Max			
I _{TCCG}	Transmitter Supply Current	-	30.4	-	mA	RL=100Ω,CL=5pF VDD=1.8V,RS[1:0]=HL Gray Scale Pattern	f=85MHz
		-	22.5	-	mA	RL=100Ω,CL=5pF VDD=1.8V,RS[1:0]=LH Gray Scale Pattern	f=85MHz
		-	20.4	-	mA	RL=100Ω,CL=5pF VDD=1.8V,RS[1:0]=LL Gray Scale Pattern	f=85MHz
I _{TCCW}	Transmitter Supply Current	-	32.4	-	mA	RL=100Ω,CL=5pF VDD=1.8V,RS[1:0]=HL Worst case Pattern	f=85MHz
		-	24.5	-	mA	RL=100Ω,CL=5pF VDD=1.8V,RS[1:0]=LH Worst case Pattern	f=85MHz
		-	22.4	-	mA	RL=100Ω,CL=5pF VDD=1.8V,RS[1:0]=LL Worst case Pattern	f=85MHz
I _{TCCS}	Transmitter Power Down Supply Current	-	-	10	μA	XRST=L	

Gray Scale Pattern

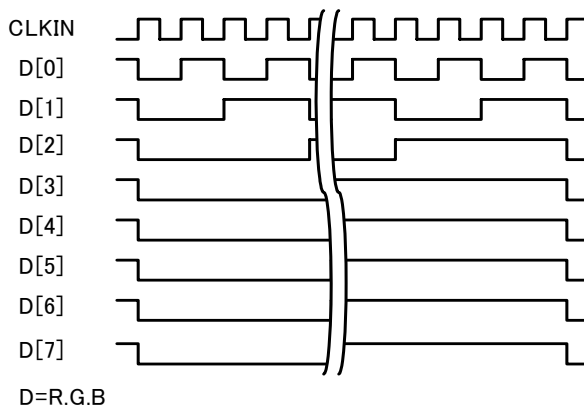

Figure -6 Gray Scale Pattern

Worst Case Pattern (Maximum Power condition)

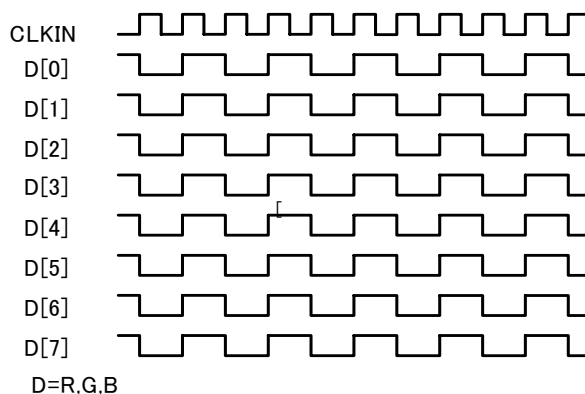
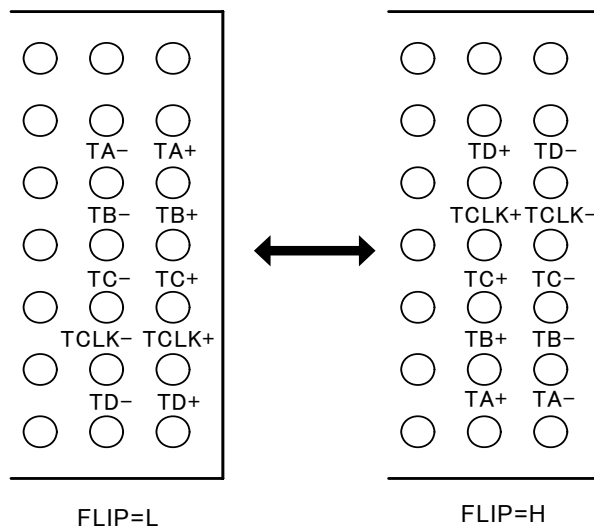

Figure -7 Worst Case Pattern

●LVDS Data Output Table for Function of FLIP pin

Table 5: LVDS Data Output Pin Name

Pin No	Output Pin Names	
	FLIP=L	FLIP=H
B7	TA+	TD-
B6	TA-	TD+
C7	TB+	TCLK-
C6	TB-	TCLK+
D7	TC+	TC-
D6	TC-	TC+
E7	TCLK+	TB-
E6	TCLK-	TB+
F7	TD+	TA-
F6	TD-	TA+



●LVCMOS Data Inputs Pixel Map Table

Table 6: LVCMOS Data Inputs Pixel Map Table

	TFT Panel Data		BU90T81 Input
	24Bit	18Bit	
LSB	R0	-	R0
	R1	-	R0
	R2	R0	R1
	R3	R1	R2
	R4	R2	R3
	R5	R3	R4
	R6	R4	R5
MSB	R7	R5	R6
LSB	G0	-	R7
	G1	-	G0
	G2	G0	G1
	G3	G1	G2
	G4	G2	G3
	G5	G3	G4
	G6	G4	G5
MSB	G7	G5	G6
LSB	B0	-	G7
	B1	-	B0
	B2	B0	B1
	B3	B1	B2
	B4	B2	B3
	B5	B3	B4
	B6	B4	B5
MSB	B7	B5	B6
	VSYNC	VSYNC	B7
	HSYNC	HSYNC	HSYNC
	DE	DE	DE

●LVDS Output Data Mapping

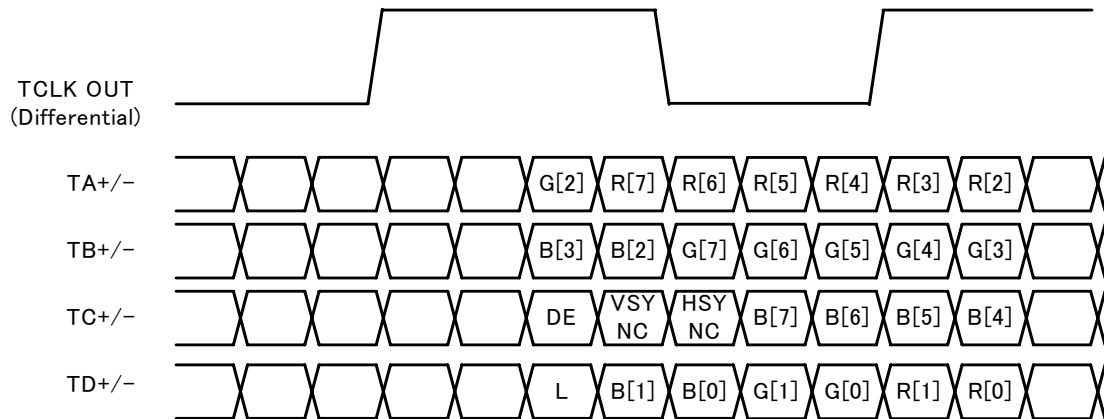

Figure-8 LVDS output mapping (6B8B=L, FLIP=L)

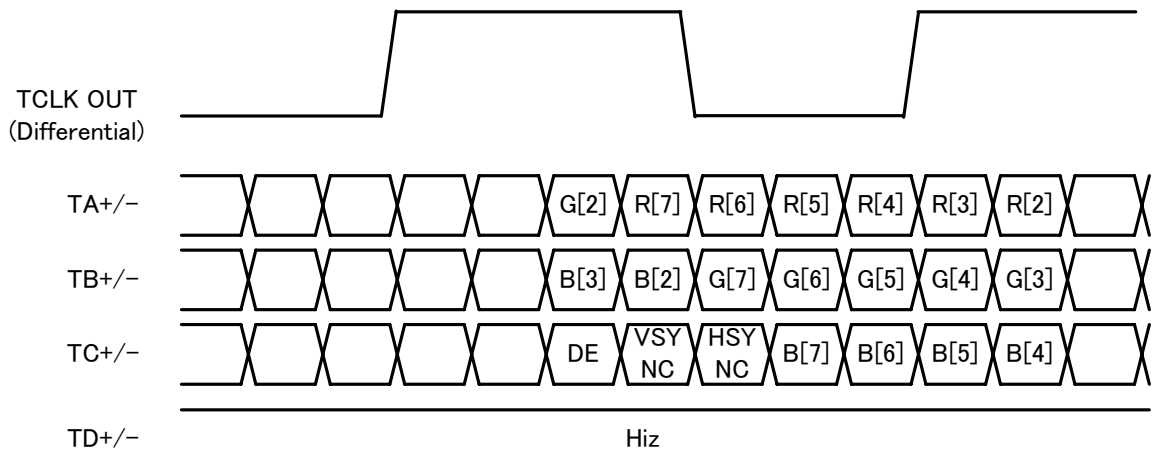

Figure-9 LVDS output mapping (6B8B=H, FLIP=L)

● Typical Application Circuit (24bit mode)

Example

BU90T81: LVCMOS Data Input /rising edge/200mV swing output/normal output mapping

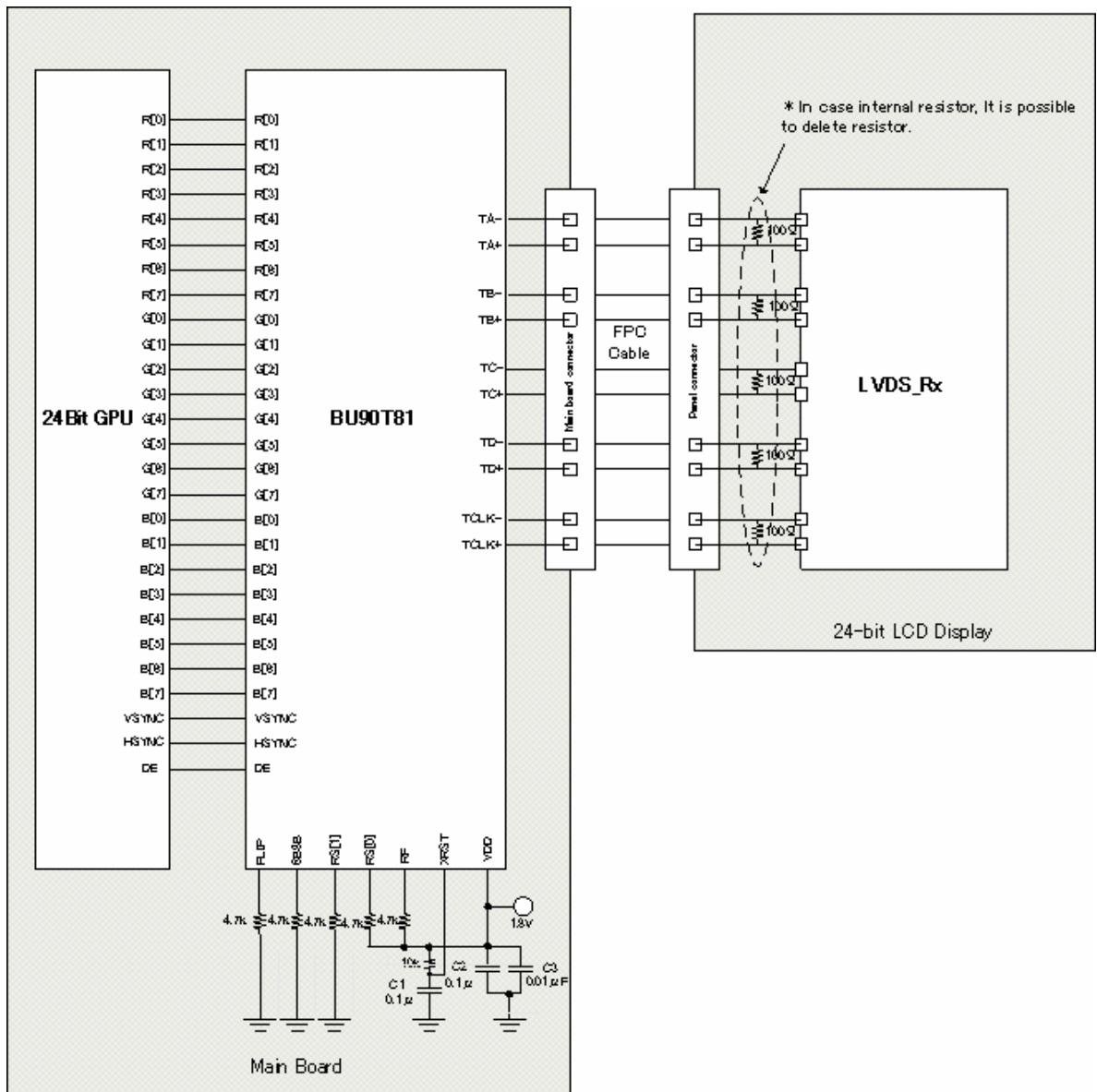

Figure-10 Application Circuit (24bit mode)

● Typical Application Circuit (18bit mode)

Example

BU90T81: LVCMOS Data Input /rising edge/200mV swing output/normal output mapping

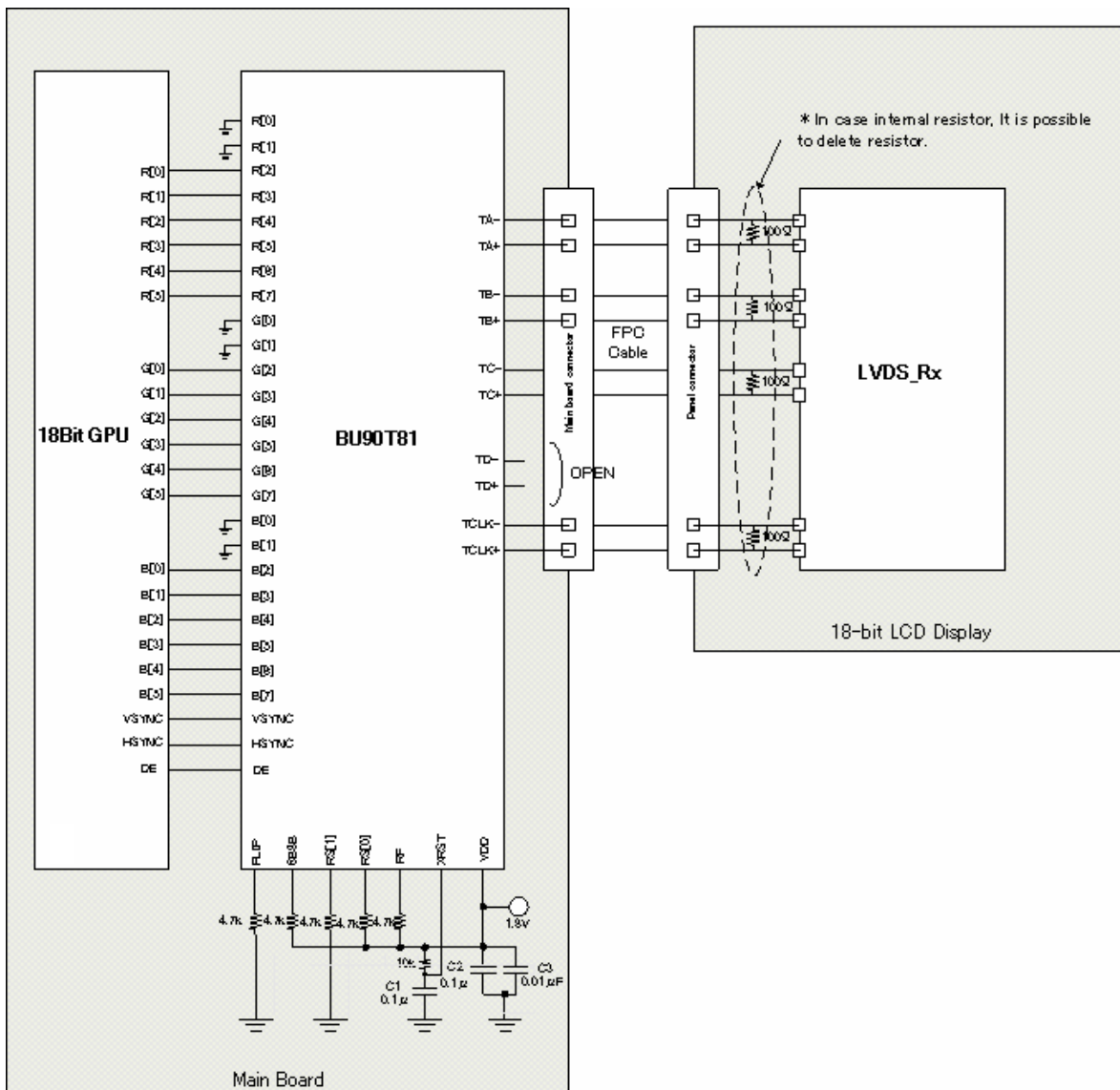

Figure-11 Application Circuit (18bit mode)

● Status of this document

The Japanese version of this document is formal specification. A customer may use this translation version only for a reference to help reading the formal version.

If there are any differences in translation version of this document formal version takes priority

Notice

Precaution on using ROHM Products

- Our Products are designed and manufactured for application in ordinary electronic equipments (such as AV equipment, OA equipment, telecommunication equipment, home electronic appliances, amusement equipment, etc.). If you intend to use our Products in devices requiring extremely high reliability (such as medical equipment ^(Note 1), transport equipment, traffic equipment, aircraft/spacecraft, nuclear power controllers, fuel controllers, car equipment including car accessories, safety devices, etc.) and whose malfunction or failure may cause loss of human life, bodily injury or serious damage to property ("Specific Applications"), please consult with the ROHM sales representative in advance. Unless otherwise agreed in writing by ROHM in advance, ROHM shall not be in any way responsible or liable for any damages, expenses or losses incurred by you or third parties arising from the use of any ROHM's Products for Specific Applications.

(Note1) Medical Equipment Classification of the Specific Applications

JAPAN	USA	EU	CHINA
CLASS III	CLASS III	CLASS II b	CLASS III
CLASS IV		CLASS III	

- ROHM designs and manufactures its Products subject to strict quality control system. However, semiconductor products can fail or malfunction at a certain rate. Please be sure to implement, at your own responsibilities, adequate safety measures including but not limited to fail-safe design against the physical injury, damage to any property, which a failure or malfunction of our Products may cause. The following are examples of safety measures:
 - Installation of protection circuits or other protective devices to improve system safety
 - Installation of redundant circuits to reduce the impact of single or multiple circuit failure
- Our Products are designed and manufactured for use under standard conditions and not under any special or extraordinary environments or conditions, as exemplified below. Accordingly, ROHM shall not be in any way responsible or liable for any damages, expenses or losses arising from the use of any ROHM's Products under any special or extraordinary environments or conditions. If you intend to use our Products under any special or extraordinary environments or conditions (as exemplified below), your independent verification and confirmation of product performance, reliability, etc. prior to use, must be necessary:
 - Use of our Products in any types of liquid, including water, oils, chemicals, and organic solvents
 - Use of our Products outdoors or in places where the Products are exposed to direct sunlight or dust
 - Use of our Products in places where the Products are exposed to sea wind or corrosive gases, including Cl₂, H₂S, NH₃, SO₂, and NO₂
 - Use of our Products in places where the Products are exposed to static electricity or electromagnetic waves
 - Use of our Products in proximity to heat-producing components, plastic cords, or other flammable items
 - Sealing or coating our Products with resin or other coating materials
 - Use of our Products without cleaning residue of flux (even if you use no-clean type fluxes, cleaning residue of flux is recommended); or Washing our Products by using water or water-soluble cleaning agents for cleaning residue after soldering
 - Use of the Products in places subject to dew condensation
- The Products are not subject to radiation-proof design.
- Please verify and confirm characteristics of the final or mounted products in using the Products.
- In particular, if a transient load (a large amount of load applied in a short period of time, such as pulse. is applied, confirmation of performance characteristics after on-board mounting is strongly recommended. Avoid applying power exceeding normal rated power; exceeding the power rating under steady-state loading condition may negatively affect product performance and reliability.
- De-rate Power Dissipation (Pd) depending on Ambient temperature (Ta). When used in sealed area, confirm the actual ambient temperature.
- Confirm that operation temperature is within the specified range described in the product specification.
- ROHM shall not be in any way responsible or liable for failure induced under deviant condition from what is defined in this document.

Precaution for Mounting / Circuit board design

- When a highly active halogenous (chlorine, bromine, etc.) flux is used, the residue of flux may negatively affect product performance and reliability.
- In principle, the reflow soldering method must be used; if flow soldering method is preferred, please consult with the ROHM representative in advance.

For details, please refer to ROHM Mounting specification

Precautions Regarding Application Examples and External Circuits

1. If change is made to the constant of an external circuit, please allow a sufficient margin considering variations of the characteristics of the Products and external components, including transient characteristics, as well as static characteristics.
2. You agree that application notes, reference designs, and associated data and information contained in this document are presented only as guidance for Products use. Therefore, in case you use such information, you are solely responsible for it and you must exercise your own independent verification and judgment in the use of such information contained in this document. ROHM shall not be in any way responsible or liable for any damages, expenses or losses incurred by you or third parties arising from the use of such information.

Precaution for Electrostatic

This Product is electrostatic sensitive product, which may be damaged due to electrostatic discharge. Please take proper caution in your manufacturing process and storage so that voltage exceeding the Products maximum rating will not be applied to Products. Please take special care under dry condition (e.g. Grounding of human body / equipment / solder iron, isolation from charged objects, setting of ionizer, friction prevention and temperature / humidity control).

Precaution for Storage / Transportation

1. Product performance and soldered connections may deteriorate if the Products are stored in the places where:
 - [a] the Products are exposed to sea winds or corrosive gases, including Cl₂, H₂S, NH₃, SO₂, and NO₂
 - [b] the temperature or humidity exceeds those recommended by ROHM
 - [c] the Products are exposed to direct sunshine or condensation
 - [d] the Products are exposed to high Electrostatic
2. Even under ROHM recommended storage condition, solderability of products out of recommended storage time period may be degraded. It is strongly recommended to confirm solderability before using Products of which storage time is exceeding the recommended storage time period.
3. Store / transport cartons in the correct direction, which is indicated on a carton with a symbol. Otherwise bent leads may occur due to excessive stress applied when dropping of a carton.
4. Use Products within the specified time after opening a humidity barrier bag. Baking is required before using Products of which storage time is exceeding the recommended storage time period.

Precaution for Product Label

QR code printed on ROHM Products label is for ROHM's internal use only.

Precaution for Disposition

When disposing Products please dispose them properly using an authorized industry waste company.

Precaution for Foreign Exchange and Foreign Trade act

Since our Products might fall under controlled goods prescribed by the applicable foreign exchange and foreign trade act, please consult with ROHM representative in case of export.

Precaution Regarding Intellectual Property Rights

1. All information and data including but not limited to application example contained in this document is for reference only. ROHM does not warrant that foregoing information or data will not infringe any intellectual property rights or any other rights of any third party regarding such information or data. ROHM shall not be in any way responsible or liable for infringement of any intellectual property rights or other damages arising from use of such information or data.:
2. No license, expressly or implied, is granted hereby under any intellectual property rights or other rights of ROHM or any third parties with respect to the information contained in this document.

Other Precaution



1. This document may not be reprinted or reproduced, in whole or in part, without prior written consent of ROHM.
2. The Products may not be disassembled, converted, modified, reproduced or otherwise changed without prior written consent of ROHM.
3. In no event shall you use in any way whatsoever the Products and the related technical information contained in the Products or this document for any military purposes, including but not limited to, the development of mass-destruction weapons.
4. The proper names of companies or products described in this document are trademarks or registered trademarks of ROHM, its affiliated companies or third parties.

General Precaution

1. Before you use our Products, you are requested to carefully read this document and fully understand its contents. ROHM shall not be in any way responsible or liable for failure, malfunction or accident arising from the use of any ROHM's Products against warning, caution or note contained in this document.
2. All information contained in this document is current as of the issuing date and subject to change without any prior notice. Before purchasing or using ROHM's Products, please confirm the latest information with a ROHM sales representative.
3. The information contained in this document is provided on an "as is" basis and ROHM does not warrant that all information contained in this document is accurate and/or error-free. ROHM shall not be in any way responsible or liable for any damages, expenses or losses incurred by you or third parties resulting from inaccuracy or errors of or concerning such information.

Looking for pricing, stock, or lifecycle information?

Click below to explore more details on WIN SOURCE:

-  [View BU90T81-E2 on WIN SOURCE](#)
-  [Rohm Semiconductor](#) Information

Optimize Your Supply Chain with WIN SOURCE Solutions

-  Global Sourcing Solution
-  Obsolete Management
-  Cost Control Management
-  Shortage Management
-  Alternative Solution
-  Excess Inventory Management