

Structure Silicon Monolithic Integrated Circuit  
Function Voltage Regulated Charge Pump IC

Product **BU90030G**

Function  
 - Input voltage range 2.0V~4.0V  
 - PFM operation  
 - Output voltage 4.0V (typ)  
 - 1.5MHz(typ) switching frequency.  
 - SSOP6 package

Absolute Maximum rating (Ta=25c)

Item	Symbol	Rating	Unit
Maximum input power supply voltage	VCC	-0.3 ~ 7	V
Maximum input voltage	CP, CN, SHD, VOUT	-0.3 ~ 7	V
Power dissipation	Pd	675 (*1)	mW
Operating temperature range	Topr	-35~+85	C
Storage temperature range	Tstg	-55~+125	C
Junction temperature	Tjmax	+125	C

\*1 When mounted on the specified PCB (70mm×70mm×1.6mm glass epoxy).  
Deducted by 6.75mW/c when used over Ta=25c.

Operating range (Ta=25c)

Item	Symbol	Rating			Unit	Condition
		Min.	Typ.	Max.		
Power supply voltage	VBAT	2.0	-	4.0	V	
Flying Capacitor	Cfly	0.1	-	1.0	uF	
Output Capacitor	CCPOUT	1.0	-	10	uF	
Maximum Output Current	IOMAX	-	-	80	mA	VCC=2.5V, Cfly=1.0uF, COUT=1.0uF

Electrical characteristics (unless otherwise specified VBAT=2.5[v], Ta=25[c])

Item	Symbol	Rating			Unit	Condition	
		Min.	Typ.	Max.			
<b>【Voltage Control part】</b>							
Output voltage 1	Vcpout1	3.8	4.0	4.2	V	Cfly=COOUT=1uF	
Output voltage 2	Vcpout2	3.6	-	-	V	VCC=2.0V, IOOUT=40mA, Cfly=COOUT=1.0uF	
<b>【Oscillator circuit】</b>							
MaximumOscillator frequency	Fosc	1.0	1.5	2.0	MHz	VCC=2.0V, VOUT=3.8V, VOUT=40mA	
<b>【Output discharge circuit】</b>							
Discharge resistor	RDIS	300	600	900	Ω	VCC=2.5V, VOUT=4.0V	
<b>【SHD part】</b>							
SHD pin pull down resistor	RSHD	100	200	400	kΩ		
SHD pin control voltage	Operation	VSHDH	1.4	-	4.0	V	
	Non operation	VSHDL	0	-	0.4	V	
<b>【Circuit current】</b>							
Circuit current at shutdown	ISHD	-	0	5	uA		

\* No design for durability against radiation

External dimention/Pin layout

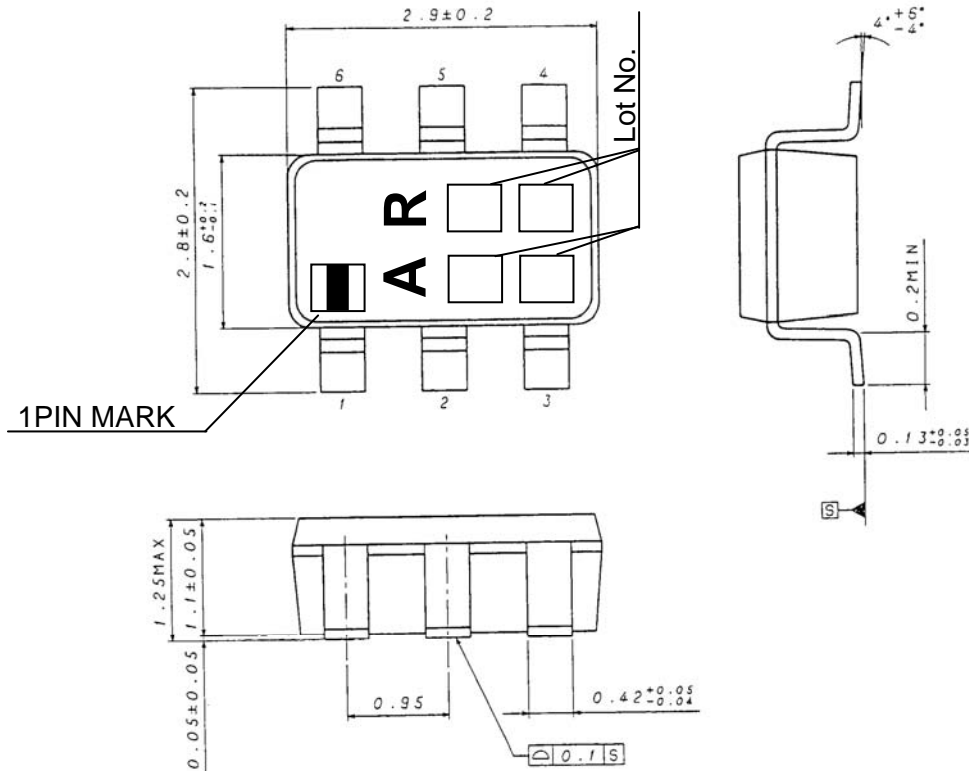

(UNIT: mm)

Block diagram

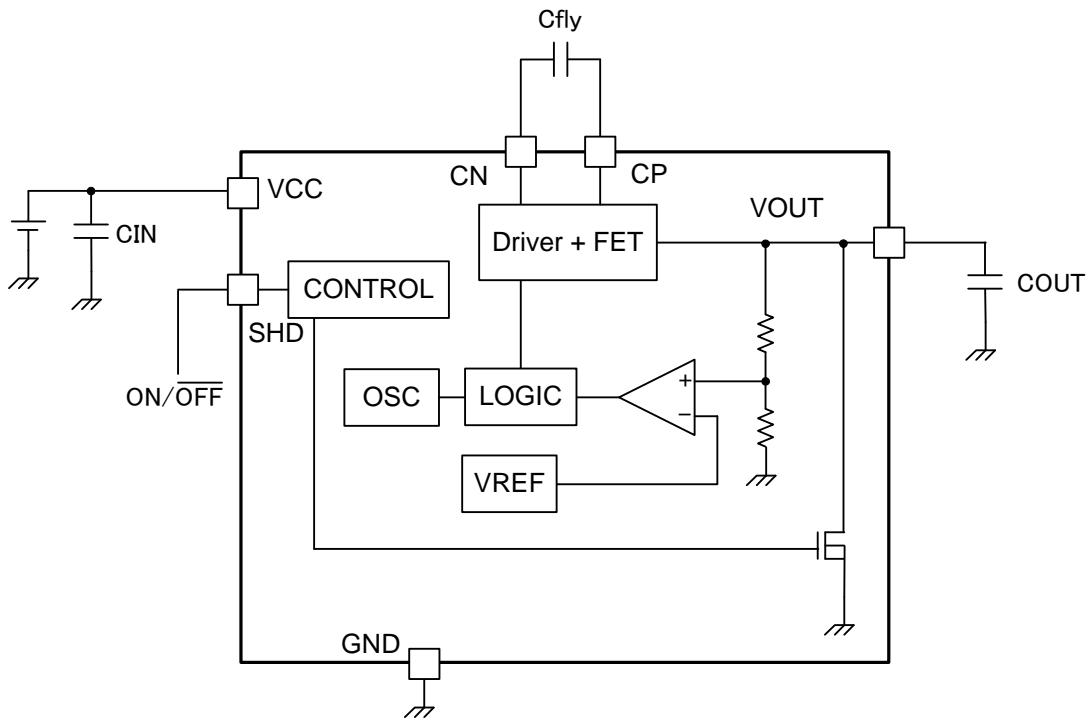

Pin number/name/function

Pin nr	Name	Function
1	VOUT	Starting charge pump output pin
2	GND	GND pin
3	SHD	Shutdown pin
4	CN	Flying Capacitor L side input pin
5	VCC	Power supply input pin
6	CP	Flying Capacitor H side input pin

Operation Notes

#### 1.) Absolute maximum ratings

An excess in the absolute maximum rating, such as supply voltage, temperature range of operating conditions, etc., can break down the devices, thus making impossible to identify breaking mode, such as a short circuit or an open circuit. If any over rated values will expect to exceed the absolute maximum ratings, consider adding circuit protection devices, such as fuses.

#### 2.) GND voltage

The potential of GND pin must be minimum potential in all condition. As an exception, the circuit design allows voltages up to -0.3 V to be applied to the IC pin.

#### 3.) Thermal design

Use a thermal design that allows for a sufficient margin in light of the power dissipation (Pd) in actual operating conditions

#### 4.) Inter-pin shorts and mounting errors

Use caution when positioning the IC for mounting on printed circuit boards. The IC may be damaged if there is any connection error or if pins are shorted together.

#### 5.) Actions in strong electromagnetic field

Use caution when using the IC in the presence of a strong electromagnetic field as doing so may cause the IC to malfunction

#### 6.) Mutual impedance

Power supply and ground wiring should reflect consideration of the need to lower mutual impedance and minimize ripple as much as possible (by making wiring as short and thick as possible or rejecting ripple by incorporating inductance and capacitance).

#### 7.) Regarding input pin of the IC

This monolithic IC contains P+ isolation and P substrate layers between adjacent elements in order to keep them isolated. P-N junctions are formed at the intersection of these P layers with the N layers of other elements, creating a parasitic diode or transistor. For example, as shown in the figures below, the relation between each potential is as follows:

When  $GND > Pin A$  and  $GND > Pin B$ , the P-N junction operates as a parasitic diode.

When  $GND > Pin B$ , the P-N junction operates as a parasitic transistor.

Parasitic diodes can occur inevitable in the structure of the IC. The operation of parasitic diodes can result in mutual interference among circuits, operational faults, or physical damage. Accordingly, methods by which parasitic diodes operate, such as applying a voltage that is lower than the GND (P substrate) voltage to an input pin, should not be used.

#### 8.) Thermal shutdown Circuit (TSD Circuit)

This model IC has a built-in TSD circuit. This circuit is only to cut off the IC from thermal runaway, and has not been design to protect or guarantee the IC. Therefore, the user should not plan to activate this circuit with continued operation in mind.

#### 9.) External Component

Use a small ESR ceramic capacitor for the external capacitor (CIN, COUT, Cfly) and set them nearby IC.

Use the CIN capacitor's value that meets this condition ( $CIN \geq COUT$ ).

And Use the Cfly capacitor's value that meets this condition ( $Cfly \leq COUT$ ).

There may be a case that it doesn't achieve the objective characteristic because the capacity come down lower than the normal capacitor because of the bias voltage and the temperature when using a small layered ceramic capacitor.

Therefore, the user should use it after checking the DC bias capacity and other characteristics.

## Notes

No copying or reproduction of this document, in part or in whole, is permitted without the consent of ROHM Co.,Ltd.

The content specified herein is subject to change for improvement without notice.

The content specified herein is for the purpose of introducing ROHM's products (hereinafter "Products"). If you wish to use any such Product, please be sure to refer to the specifications, which can be obtained from ROHM upon request.

Examples of application circuits, circuit constants and any other information contained herein illustrate the standard usage and operations of the Products. The peripheral conditions must be taken into account when designing circuits for mass production.

Great care was taken in ensuring the accuracy of the information specified in this document. However, should you incur any damage arising from any inaccuracy or misprint of such information, ROHM shall bear no responsibility for such damage.

The technical information specified herein is intended only to show the typical functions of and examples of application circuits for the Products. ROHM does not grant you, explicitly or implicitly, any license to use or exercise intellectual property or other rights held by ROHM and other parties. ROHM shall bear no responsibility whatsoever for any dispute arising from the use of such technical information.

The Products specified in this document are intended to be used with general-use electronic equipment or devices (such as audio visual equipment, office-automation equipment, communication devices, electronic appliances and amusement devices).

The Products specified in this document are not designed to be radiation tolerant.

While ROHM always makes efforts to enhance the quality and reliability of its Products, a Product may fail or malfunction for a variety of reasons.

Please be sure to implement in your equipment using the Products safety measures to guard against the possibility of physical injury, fire or any other damage caused in the event of the failure of any Product, such as derating, redundancy, fire control and fail-safe designs. ROHM shall bear no responsibility whatsoever for your use of any Product outside of the prescribed scope or not in accordance with the instruction manual.

The Products are not designed or manufactured to be used with any equipment, device or system which requires an extremely high level of reliability the failure or malfunction of which may result in a direct threat to human life or create a risk of human injury (such as a medical instrument, transportation equipment, aerospace machinery, nuclear-reactor controller, fuel-controller or other safety device). ROHM shall bear no responsibility in any way for use of any of the Products for the above special purposes. If a Product is intended to be used for any such special purpose, please contact a ROHM sales representative before purchasing.

If you intend to export or ship overseas any Product or technology specified herein that may be controlled under the Foreign Exchange and the Foreign Trade Law, you will be required to obtain a license or permit under the Law.



Thank you for your accessing to ROHM product informations.  
More detail product informations and catalogs are available, please contact us.

## ROHM Customer Support System

<http://www.rohm.com/contact/>

## Looking for pricing, stock, or lifecycle information?

Click below to explore more details on WIN SOURCE:

-  [View BU90030G-TR on WIN SOURCE](#)
-  [Rohm Semiconductor](#) Information

## Optimize Your Supply Chain with WIN SOURCE Solutions

-  Global Sourcing Solution
-  Obsolete Management
-  Cost Control Management
-  Shortage Management
-  Alternative Solution
-  Excess Inventory Management