



**THE DATASHEET OF  
CR-10JA7--820R**



## Data Sheet

Customer:

Product: Automotive Grade Chip Resistor – CR..A Series

Size: 0201/0402/0603/0805/1206/1210/2010/2512

Issued Date: 01-Aug-23

Edition: REV.C1



VIKING TECH CORPORATION  
光頡科技股份有限公司  
No.70 Guangfu N. Rd., Hukou  
Township, Hsinchu County 303,  
Taiwan

TEL:886-3-5972931  
FAX:886-3-5972935•886-3-5973494  
E-mail:sales@viking.com.tw

VIKING TECH CORPORATION KAOHSIUNG BRANCH  
光頡科技股份有限公司高雄分公司  
No.248-3, Sin-Sheng Rd., Cian-Jhen Dist., Kaohsiung,  
806, Taiwan

TEL:886-7-8217999  
FAX:886-7-8228229  
E-mail:sales@viking.com.tw

VIKING ELECTRONICS (WUXI) CO., LTD.  
光頡電子(無錫)有限公司  
No.22 Xixia Road, Machinery & Industry Park,  
National Hi-Tech Industrial Development Zone  
of Wuxi, Wuxi, Jiangsu Province, China  
Zip Code:214028  
TEL:86-510-85203339  
FAX:86-510-85203667•86-510-85203977  
E-mail:china@viking.com.tw

Produced by (QC)	Checked (QC)	Approved by (QC)	Prepared by (Sales)	Accepted by (Customer)
01-Aug-23	01-Aug-23	01-Aug-23		
<b>Alice Hsiao</b>	<b>Susan Huang</b>	<b>Susan Huang</b>		

## Automotive Grade Chip Resistor-CR..A Series



### Scope

- This specification applies to all sizes of rectangular-type fixed chip resistors with Ruthenium-base as material.

### Features

- AEC-Q200 Compliance
- Highly reliable multilayer electrode construction
- Special construction to prevent sulfuration in a sulfur containing environment
- Compatible with all soldering process
- 100% CCD inspection

### Construction

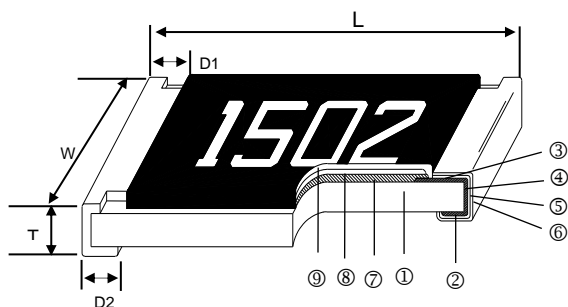

### Applications

- Automotive Industry
- Telecommunication Equipments
- Radio and Tape Recorders, TV Tuners
- Digital Cameras, Watches, Pocket Calculators
- Computers, Instruments
- Medical Equipment

① Alumina Substrate	④ Edge Electrode	⑦ Resistor Layer
② Bottom Electrode	⑤ Barrier Layer	⑧ Primary Overcoat
③ Top Electrode	⑥ External Electrode	⑨ Secondary Overcoat

### Dimensions

Type	Size (Inch)	L (mm)	W (mm)	T (mm)	D1 (mm)	D2 (mm)	Weight (g) (1000pcs)
CR-01	0201	0.60±0.03	0.30±0.03	0.23±0.03	0.15±0.05	0.15±0.05	0.150
CR-02	0402	1.00±0.05	0.50±0.05	0.35±0.05	0.20±0.10	0.20±0.10	0.620
CR-03	0603	1.60±0.10	0.80±0.10	0.45±0.10	0.30±0.20	0.30±0.20	2.042
CR-05	0805	2.00±0.10	1.25±0.10	0.50±0.10	0.35±0.20	0.40±0.20	4.368
CR-06	1206	3.10±0.10	1.55±0.10	0.55±0.10	0.50±0.25	0.50±0.20	8.947
CR-10	1210	3.10±0.10	2.60±0.15	0.55±0.10	0.50±0.25	0.50±0.20	15.959
CR-0A	2010	5.00±0.10	2.50±0.15	0.55±0.10	0.60±0.25	0.50±0.20	24.241
CR-12	2512	6.35±0.10	3.10±0.15	0.55±0.10	0.60±0.25	0.50±0.20	39.448

**Part Numbering**

Part Number : CR-03FA7---10R

CR-	03	F	A	7	- - - 1 0 R
<b>Product Type</b>	<b>Dimensions</b>	<b>Resistance Tolerance</b>	<b>Function Code</b>	<b>Packaging Code</b>	<b>Resistance</b>
CR-	01: 0201 02: 0402 03: 0603 05: 0805 06: 1206 10: 1210 0A: 2010 12: 2512	D: $\pm 0.5\%$ F: $\pm 1\%$ J: $\pm 5\%$	A: Automotive Grade C: High Power & Automotive Grade D: High Power 1 & Automotive Grade U: Ultra High Power & Automotive Grade	4: 7" Reel 4Kpcs 6: 7" Reel 10Kpcs 7: 7" Reel 5Kpcs 9: 10" Reel 8Kpcs A: 10" Reel 10Kpcs B: 10" Reel 20Kpcs C: 13" Reel 40Kpcs D: 13" Reel 20Kpcs	--- 1R2: 1.2 $\Omega$ --- 3K3: 3.3K $\Omega$ --- 10K: 10K $\Omega$ -- 100K: 100K $\Omega$ “-“ to fill up 6 spaces

**Recommend Land Pattern**

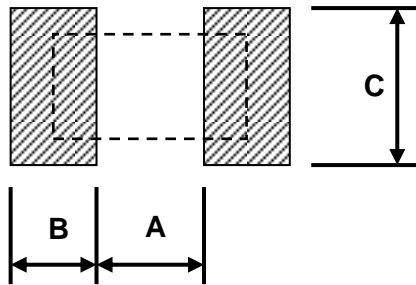

Type	A (mm)	B (mm)	C (mm)
CR-01	0.30	0.25	0.30
CR-02	0.50	0.45	0.60
CR-03	0.90	0.60	0.90
CR-05	1.20	0.70	1.30
CR-06	2.00	0.90	1.60
CR-10	2.00	0.90	2.80
CR-0A	3.80	0.90	2.80
CR-12	4.90	1.60	3.50

**Derating Curve**

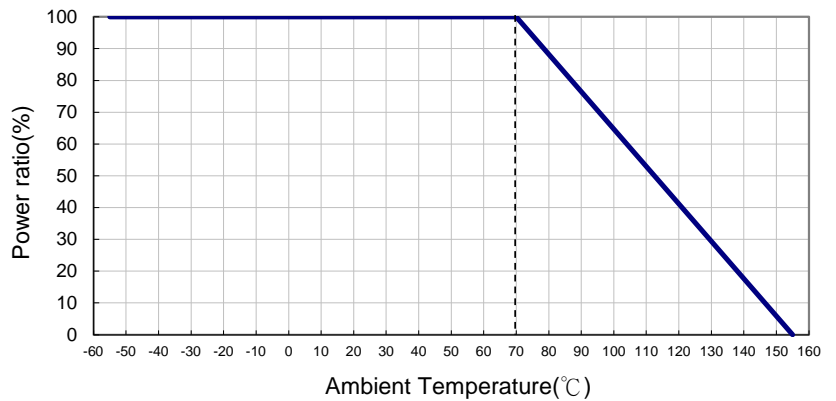

**Soldering Condition (Ref. IPC/JEDEC J-STD-020 & J-STD-002)**

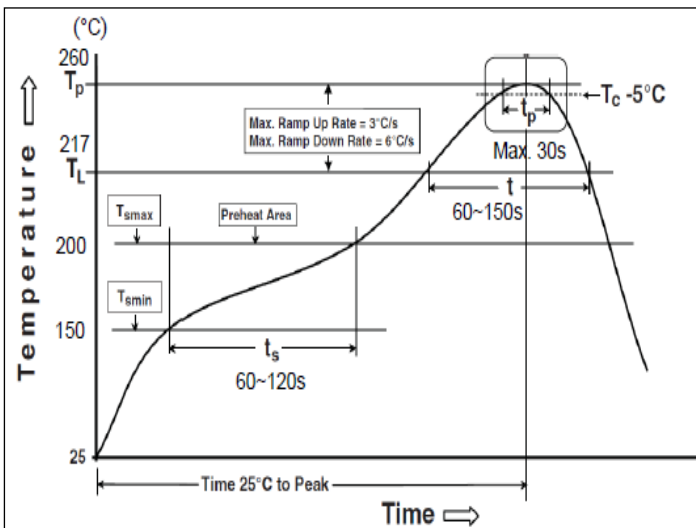

Reflow Profiles	
Profile Feature	Pb-Free Assembly
<b>Preheat</b>	
Min. Temperature (T <sub>min</sub> )	150 °C
Max Temperature (T <sub>max</sub> )	200 °C
Preheating time (t <sub>s</sub> ) from (T <sub>min</sub> to T <sub>max</sub> )	60-120 seconds
Ramp-up rate (T <sub>L</sub> to T <sub>p</sub> )	3 °C/second max.
Liquidous temperature (T <sub>L</sub> )	217 °C
Time (t <sub>L</sub> ) maintained above T <sub>L</sub>	60-150 seconds
Min. Peak temperature (T <sub>p</sub> min)	235°C
Max. Peak temperature (T <sub>p</sub> max)	260°C
Time (t <sub>p</sub> ) within 5 °C of the specified classification temperature (T <sub>c</sub> )	30 seconds max.
Ramp-down rate (T <sub>p</sub> to T <sub>L</sub> )	6 °C/second max.
Time 25 °C to peak temperature	8 minutes max.

**Standard Electrical Specifications**

Type \ Item	Power Rating at 70°C Jumper Rated Current	Operating Temp. Range	Max. Operating Voltage	Max. Overload Voltage	Resistance Range		TCR (PPM/°C)
					±1%(E24、E96)	±5%(E24)	
CR-01 (0201)	1/20W	-55 ~ +155°C	25V	50V	1Ω - 10MΩ		±200
CR-02 (0402)	1/16W	-55 ~ +155°C	50V	100V	1Ω - 9.76Ω 10Ω - 1MΩ 1.02MΩ - 10MΩ		±200 ±100 ±200
CR-03 (0603)	1/10W	-55 ~ +155°C	75V	150V	1Ω - 9.76Ω 10Ω - 1MΩ 1.02MΩ - 10MΩ		±200 ±100 ±200
CR-05 (0805)	1/8W	-55 ~ +155°C	150V	300V	1Ω - 9.76Ω 10Ω - 1MΩ 1.02MΩ - 10MΩ		±200 ±100 ±200
CR-06 (1206)	1/4W	-55 ~ +155°C	200V	400V	1Ω - 9.76Ω 10Ω - 1MΩ 1.02MΩ - 10MΩ		±200 ±100 ±200
CR-10 (1210)	1/2W	-55 ~ +155°C	200V	400V	1Ω - 9.76Ω 10Ω - 1MΩ 1.02MΩ - 10MΩ		±200 ±100 ±200
CR-0A (2010)	3/4W	-55 ~ +155°C	400V	800V	1Ω - 9.76Ω 10Ω - 1MΩ 1.02MΩ - 10MΩ		±200 ±100 ±200
CR-12 (2512)	1W	-55 ~ +155°C	500V	1000V	1Ω - 9.76Ω 10Ω - 1MΩ 1.02MΩ - 10MΩ		±200 ±100 ±200

**High Precision Electrical Specifications**

Type \ Item	Power Rating at 70°C	Operating Temp. Range	Max. Operating Voltage	Max. Overload Voltage	Resistance Range (E24、E96)	TCR (PPM/°C)
					±0.5%	
CR-02 (0402)	1/16W	-55 ~ +155°C	50V	100V	10Ω - 1MΩ	±100
CR-03 (0603)	1/10W		75V	150V	10Ω - 1MΩ	±100
CR-05 (0805)	1/8W		150V	300V	10Ω - 1MΩ	±100
CR-06 (1206)	1/4W		200V	400V	10Ω - 1MΩ	±100
CR-10 (1210)	1/3W		200V	400V	10Ω - 1MΩ	±100
CR-0A (2010)	3/4W		400V	800V	10Ω - 1MΩ	±100
CR-12 (2512)	1W		500V	1000V	10Ω - 1MΩ	±100

**Jumper(0Ω)**

Type \ Item	Rated Current	Function Code	Resistance	Operating Temp. Range
			0Ω 5%	
CR-01 (0201)	1A	A	<50mΩ	-55 ~ +155°C
CR-02 (0402)	1A			
CR-03 (0603)	1A			
CR-05 (0805)	2A			
CR-06 (1206)	2A			
CR-10 (1210)	2.5A			
CR-0A (2010)	3.5A			
CR-12 (2512)	4A			

**High Power Rating Electrical Specifications**

Type	Item	Power Rating at 70°C	Function Code	Operating Temp. Range	Max. Operating Voltage	Max. Overload Voltage	Resistance Range			TCR (PPM/°C)
							±0.5% (E24 · E96)	±1% (E24 · E96)	±5% (E24)	
CR-02 (0402)		1/10W	D	-55 ~ +155°C	50V	100V	-	1Ω - 9.76Ω		±200
		1/8W	C				10Ω - 1MΩ		±100	
CR-03 (0603)		1/4W	C		75V	150V	-	1Ω - 9.76Ω		±200
							10Ω - 1MΩ		±100	
CR-05 (0805)		1/3W	C		150V	300V	-	1Ω - 9.76Ω		±200
							10Ω - 1MΩ		±100	
CR-06 (1206)		1/2W	C		200V	400V	-	1Ω - 9.76Ω		±200
							10Ω - 1MΩ		±100	
CR-10 (1210)		1W	C		200V	400V	-	1Ω - 9.76Ω		±200
							10Ω - 1MΩ		±100	
CR-0A (2010)		1W	C		200V	400V	-	1Ω - 9.76Ω		±200
		1.25W	U				10Ω - 1MΩ		±100	
CR-12 (2512)		2W	C	250V	500V	-	1Ω - 9.76Ω		±200	
						10Ω - 1MΩ		±100		

Operating Voltage= $\sqrt{P \cdot R}$  or Max. Operating Voltage listed above, whichever is lower.

Overload Voltage= $2.5 \cdot \sqrt{P \cdot R}$  or Max. Overload Voltage listed above, whichever is lower.

The power rating depends on the maximum temperature of the resistive element. Due to the power dissipation of the resistor, the temperature of the resistive element will rise depending on the condition of heat dissipation from PCB. The maximum power rating in application only applies if the temperature of the resistive element is not exceed 155 °C.

■ Viking is capable of manufacturing the optional spec based on customer's requirement.

**Temperature Rise**

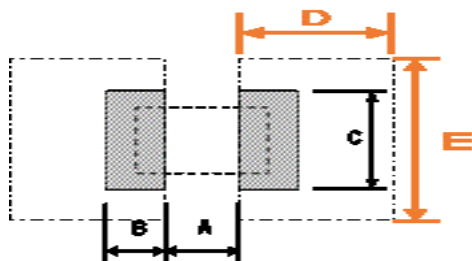
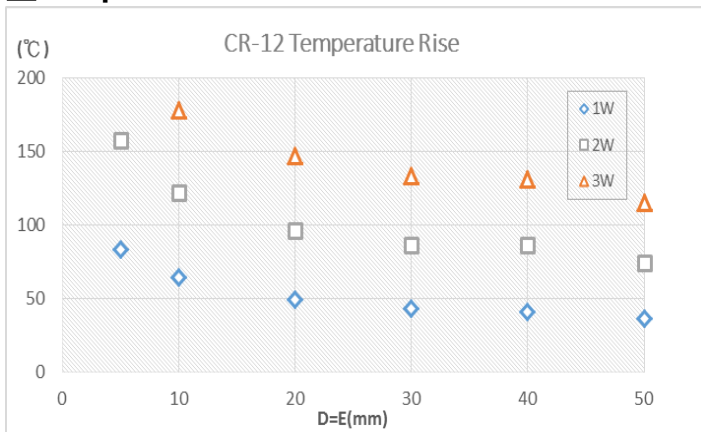

\*FR4 copper board, 35μm of copper pad thickness.

**Environmental Characteristics**

Item	Requirement			Test Method
	±1% and Below	±5%	Jumper	
Temperature Coefficient of Resistance (T.C.R.)	As Spec.			<b>JIS-C-5201-1 4.8</b> <b>IEC-60115-1 4.8</b> At 25°C/-55°C and 25°C/+125°C, 25°C is the reference temperature
Short Time Overload	±(1.0%+0.05Ω)	±(2.0%+0.05Ω)	<50mΩ	<b>JIS-C-5201-1 4.13</b> <b>IEC-60115-1 4.13</b> RCWV*2.5 or Max. Overload Voltage whichever is lower for 5 seconds
Insulation Resistance	≥10G			<b>JIS-C-5201-1 4.6</b> <b>IEC-60115-1 4.6</b> Max. Overload Voltage for 1 minute
Operational Life	±(1.0%+0.10Ω)	±(2.0%+0.10Ω)	<100mΩ	<b>MIL-STD-202 Method 108</b> Condition D Steady State TA=125°C at derated power. Measurement at 24±4 hours after test conclusion.
Biased Humidity	±(1.0%+0.10Ω)	±(2.0%+0.10Ω)	<100mΩ	<b>MIL-STD-202 Method 103</b> 1000 hrs 85°C/85%RH 10% of operating power
High Temperature Exposure	±(1.0%+0.05Ω)	±(1.5%+0.10Ω)	<50mΩ	<b>MIL-STD-202 Method 108</b> at +155°C for 1000 hrs
Board Flex	±(0.25%+0.05Ω)	±(1.0%+0.05Ω)	<50mΩ	<b>AEC-Q200-005</b> Bending once for 60 seconds 2010, 2512 sizes: 2mm Other sizes: 3mm
Solderability	95% min. coverage			<b>JIS-C-5201-1 4.17</b> <b>IEC-60115-1 4.17</b> <b>J-STD-002</b> 245±5°C for 3 seconds
Resistance to Soldering Heat	±(0.25%+0.05Ω)	±(1.0%+0.05Ω)	<50mΩ	<b>MIL-STD-202 Method 210</b> 260±5°C for 10 seconds
Voltage Proof	No breakdown or flashover			<b>JIS-C-5201-1 4.7</b> <b>IEC-60115-1 4.7</b> 1.42 times Max. Operating Voltage for 1 minute
Leaching	Individual leaching area ≤ 5% Total leaching area ≤ 10%			<b>JIS-C-5201-1 4.18</b> <b>IEC-60068-2-58 8.2.1</b> 260±5°C for 30 seconds
Temperature Cycling	±(0.5%+0.05Ω)	±(1.5%+0.05Ω)	<50mΩ	<b>JESD22 Method JA-104</b> -55°C to +125°C, 1000 cycles
Mechanical Shock	±(0.25%+0.05Ω)	±(1.0%+0.05Ω)	<50mΩ	<b>MIL-STD-202 Method 213</b> Wave Form: Tolerance for half sine shock pulse. Peak value is 100g's. Normal duration (D) is 6.
Vibration	±(0.5%+0.05Ω)	±(1.0%+0.05Ω)	<50mΩ	<b>MIL-STD-202 Method 204</b> 5 g's for 20 min., 12 cycles each of 3 orientations, 10-2000 Hz
ESD	±(3%+0.05Ω)			<b>AEC-Q200-002</b> Human body model 0201: 0.5KV 0402/0603: 1KV 0805 and above: 2KV
	±(1%+0.05Ω)			<b>IEC61340-3-1(Equivalent to MIL-STD-883)</b> 3 positive + 3 negative discharges ESD voltage acc. to size

**Automotive Grade Chip Resistor**

Item	Requirement			Test Method
	±1% and Below	±5%	Jumper	
Resistance to Solvents	No visible damage on appearance and marking.			<b>MIL-STD-202 Method 215</b> Add Aqueous wash chemical - OKEM Clean or equivalent. Do not use banned solvents.
Terminal Strength	No broken			<b>AEC-Q200-006</b> Force of 1.8kg for 60 seconds.
Flammability	No ignition of the tissue paper or scorching or the pinewood board			<b>UL-94</b> V-0 or V-1 are acceptable. Electrical test not required.
Sulfur Test	△R±1%		<50mΩ	<b>EIA-977 (Condition A)</b> 60±2°C, no power rating for 500 hrs.

RCWV(Rated Continuous Working Voltage)= $\sqrt{P \cdot R}$  or Max. Operating Voltage whichever is lower.

■ **Storage Temperature: 15~28°C; Humidity < 80%RH**

■ **Shelf Life: 2 years from production date.**

**■ Packaging**

Reel Specifications & Packaging Quantity

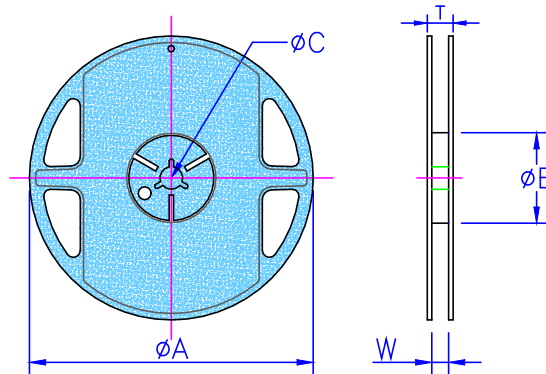

Type	Packaging Quantity	Tape Width	Reel Diameter	ΦA (mm)	ΦB (mm)	ΦC (mm)	W (mm)	T (mm)	
CR-01 CR-02	Paper	10K	8mm	7 inch	178.5±1.5	60 <sup>+1/-0</sup>	13.0±0.2	9.0±0.5	12.5±0.5
		20K	8mm	10 inch	254±1.0	100±0.5	13.0±0.2	9.5±0.5	13.5±0.5
		40K	8mm	13 inch	330±1.0	100±0.5	13.0±0.2	9.5±0.5	13.5±0.5
CR-03 CR-05 CR-06 CR-10	Paper	5K	8mm	7 inch	178.5±1.5	60 <sup>+1/-0</sup>	13.0±0.2	9.0±0.5	12.5±0.5
		10K	8mm	10 inch	254±1.0	100±0.5	13.0±0.2	9.5±0.5	13.5±0.5
		20K	8mm	13 inch	330±1.0	100±0.5	13.0±0.2	9.5±0.5	13.5±0.5
CR-0A CR-12	Embossed	4K	12mm	7 inch	178.5±1.5	60 <sup>+1/-0</sup>	13.0±0.5	13.0±0.5	15.5±0.5
		8K	12mm	10 inch	250±1.0	62±0.5	13.0±0.5	12.5±0.5	16.5±0.5

Paper Tape Specifications

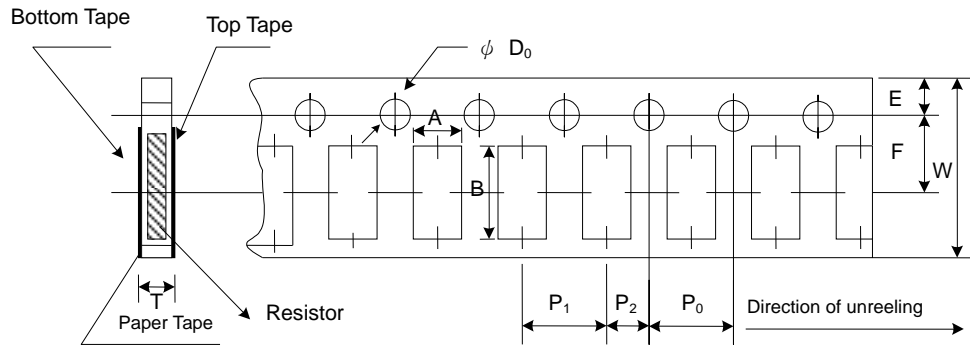

Type	A (mm)	B (mm)	W (mm)	E (mm)	F (mm)	P <sub>0</sub> (mm)	P <sub>1</sub> (mm)	P <sub>2</sub> (mm)	ΦD <sub>0</sub> (mm)	T (mm)
CR-01	0.38±0.05	0.68±0.05	8.0±0.20	1.75±0.10	3.50±0.05	4.00±0.10	2.00±0.05	2.00±0.05	1.50+0.1,-0	0.42±0.20
CR-02	0.65±0.10	1.15±0.10	8.0±0.20	1.75±0.10	3.50±0.05	4.00±0.10	2.00±0.05	2.00±0.05	1.50+0.1,-0	0.45±0.10
CR-03	1.10±0.10	1.90±0.10	8.0±0.20	1.75±0.10	3.50±0.05	4.00±0.10	4.00±0.05	2.00±0.05	1.50+0.1,-0	0.70±0.10
CR-05	1.60±0.10	2.40±0.20	8.0±0.20	1.75±0.10	3.50±0.05	4.00±0.10	4.00±0.05	2.00±0.05	1.50+0.1,-0	0.85±0.10
CR-06	1.90±0.10	3.50±0.20	8.0±0.20	1.75±0.10	3.50±0.05	4.00±0.10	4.00±0.05	2.00±0.05	1.50+0.1,-0	0.85±0.10
CR-10	2.90±0.10	3.50±0.20	8.0±0.20	1.75±0.10	3.50±0.05	4.00±0.10	4.00±0.05	2.00±0.05	1.50+0.1,-0	0.85±0.10

Embossed Plastic Tape Specifications

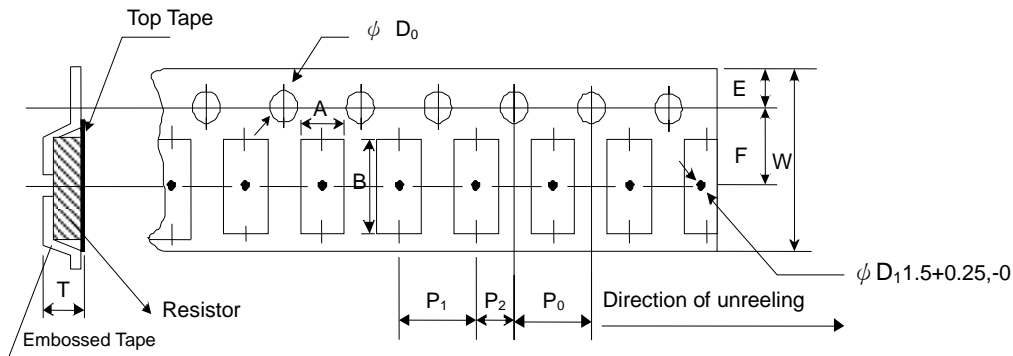

Type	A (mm)	B (mm)	W (mm)	E (mm)	F (mm)	P <sub>0</sub> (mm)	P <sub>1</sub> (mm)	P <sub>2</sub> (mm)	ΦD <sub>0</sub> (mm)	T (mm)
CR-0A	2.8±0.10	5.40±0.20	12.0±0.30	1.75±0.10	5.5±0.05	4.00±0.10	4.00±0.10	2.00±0.05	1.50+0.1, -0	1.2 <sup>+0</sup>
CR-12	3.5±0.10	6.7±0.10	12.0±0.30	1.75±0.10	5.5±0.05	4.00±0.10	4.00±0.10	2.00±0.05	1.50+0.1, -0	1.2 <sup>+0</sup>

**■ Marking**

No Marking for 0201/0402

Jumper for all: Letter "0"

1% for 0805/0612/1206/1210/2010/2512: 4 digits marking

Example:

Resistance	100Ω	2.2KΩ	10KΩ	49.9KΩ	100KΩ
Marking	1000	2201	1002	4992	1003

5% for 0603/0805/0612/1206/1210/2010/2512: 3 digits marking in E24

Example: 101=100Ω 102=1KΩ (1<sup>st</sup> and 2<sup>nd</sup> are E24 code and 3<sup>rd</sup> code is multiplier)

E24 code	10	11	12	13	15	16	18	20	22	24	27	30	33	36	39	43	47	51	56	62	68	75	82	91
----------	----	----	----	----	----	----	----	----	----	----	----	----	----	----	----	----	----	----	----	----	----	----	----	----

1% for 0603(E24): 3 digits marking in E24, When the E24 and E96 are the same resistance, this marking in E96

Example: 01A= 100Ω 05C=11KΩ 123=12KΩ 273=27KΩ

1% for 0603(E96): 3 digits marking in E96

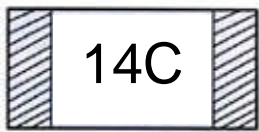

3 digits marking for Example: 14C=13K7Ω 13C=13K3Ω  
68B=4K99Ω 68X=49.9Ω

**Marking Table**

Code	E96	Code	E96	Code	E96	Code	E96				
01	100	25	178	49	316	73	562				
02	102	26	182	50	324	74	576				
03	105	27	187	51	332	75	590				
04	107	28	191	52	340	76	604				
05	110	29	196	53	348	77	619				
06	113	30	200	54	357	78	634				
07	115	31	205	55	365	79	649				
08	118	32	210	56	374	80	665				
09	121	33	215	57	383	81	681				
10	124	34	221	58	392	82	698				
11	127	35	226	59	402	83	715				
12	130	36	232	60	412	84	732				
13	133	37	237	61	422	85	750				
14	137	38	243	62	432	86	768				
15	140	39	249	63	442	87	787				
16	143	40	255	64	453	88	806				
17	147	41	261	65	464	89	825				
18	150	42	267	66	475	90	845				
19	154	43	274	67	487	91	866				
20	158	44	280	68	499	92	887				
21	162	45	287	69	511	93	909				
22	165	46	294	70	523	94	931				
23	169	47	301	71	536	95	953				
24	174	48	309	72	549	96	976				
Code	A	B	C	D	E	F	G	X	Y		
Multiplier	10 <sup>0</sup>	10 <sup>1</sup>	10 <sup>2</sup>	10 <sup>3</sup>	10 <sup>4</sup>	10 <sup>5</sup>	10 <sup>6</sup>	10 <sup>-1</sup>	10 <sup>-2</sup>		

### ■ Pulse withstanding capacity

The limit of acceptance was a shift in resistance of less than 1% from the initial value. The power applied was subject to the restrictions of the maximum permissible impulse voltage.

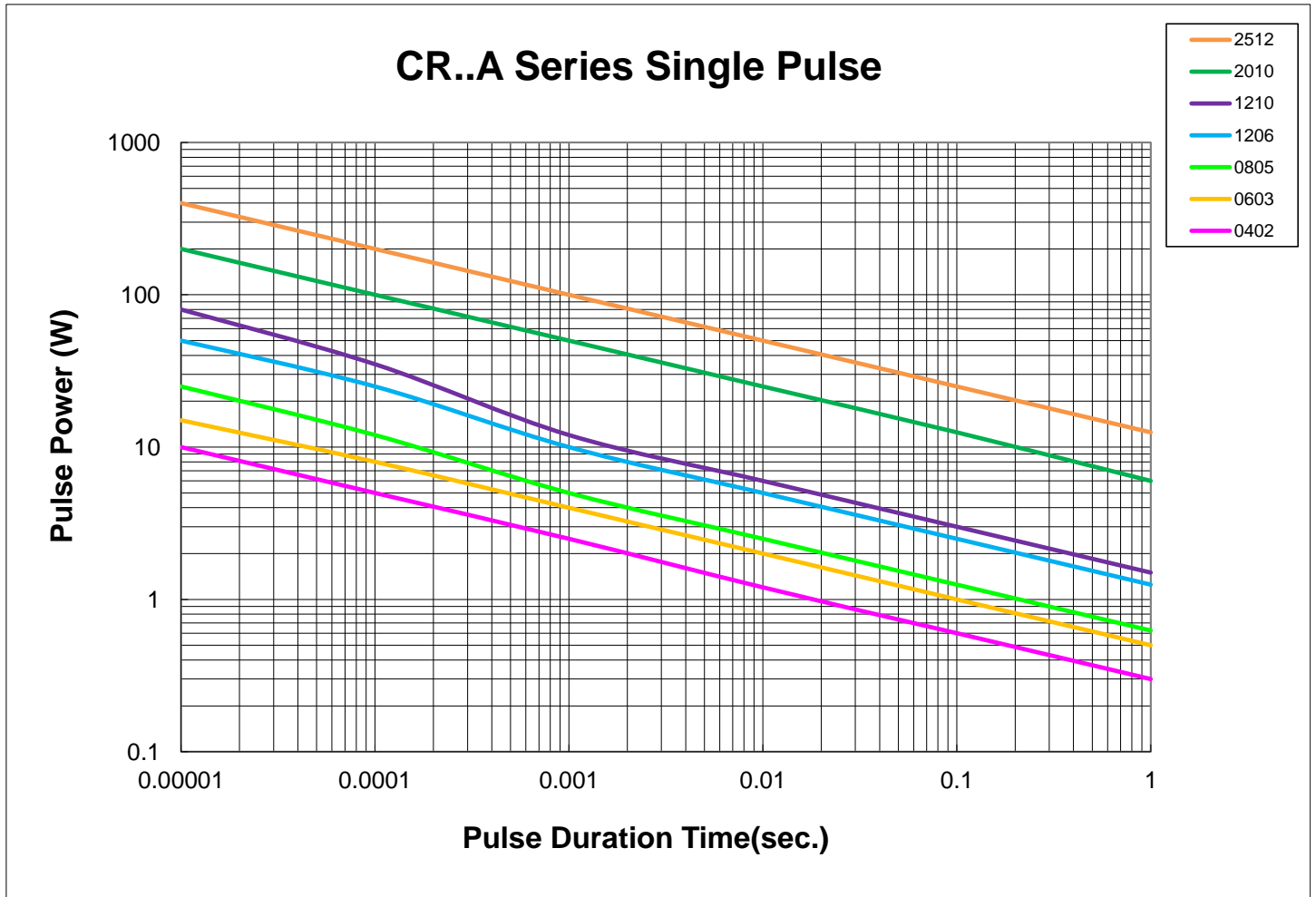

**Note:** The limit of the applicable voltage is the max. overload voltage. Please consult us about the resistance characteristic when pulse is applied continuously. This data is a reference value, please be sure to test the products on the actual circuit before you use them.

**REVISION HISTORY**

REVISION	DATE	CHANGE NOTIFICATION	DESCRIPTION
Version A5	Apr 30, 2015	-	- Environmental Characteristics updated
Version A6	Jun 18, 2015	-	- Increased 0603(E24) 1% marking description
Version A7	Jul 15, 2016	-	- Remove Material Description - Size CR-01 specifications added - Modify Storage Temperature - Increased 0.5% Resistance Range - Increased High Power Rating Electrical Specifications
Version A8	Jan 12, 2018	-	- Environmental Characteristics updated - Modify Electrical Specifications (0R) - Modify 2512 Land Pattern
Version A9	May 20, 2019	-	- Modify TCR Test description - Features added 100% CCD inspection - Added Sulfur Test
Version B	Jun 1, 2019	-	- Modify ESD Test description & Spec.
Version B1	Oct 21, 2019	-	- increase 2512 2W Specifications - increase Special standard packaging specifications (disc 10" & 13")
Version B2	Jan 31, 2020	-	- Features added Anti-sulfur characteristics
Version B3	May 22, 2020	-	- Added Temperature Rise - Modify High Power Rating Electrical Specifications ( added 0.5% )
Version B4	Sep 25, 2020	-	- increase 0612 Specifications
Version B5	Mar 10, 2021	-	- Delete 0612 size Specifications - Modify 2010 Embossed Plastic Tape B Specification - Modify Soldering Condition (IPC/JEDEC J-STD-020)
Version B6	Nov 15, 2021	-	- Increase the shelf life description
Version B7	Jan 26, 2022	-	- 0201 Operating temperature rises to 155°C
Version B8	Feb 15, 2022	-	- Derating Curve changes the temperature range
Version B9	Jun 15, 2022	-	- Modify Soldering Condition
Version C	Jul 13, 2023	-	- Increase 0402 0.1W - Increase 2010/2512 Specifications - Environmental Characteristics updated
Version C1	Aug 1, 2023	-	- Increase 1210 1W - Increase 2010 1.25W

## Looking for pricing, stock, or lifecycle information?

Click below to explore more details on WIN SOURCE:

- ⊖ [View CR-10JA7--820R on WIN SOURCE](#)
- ⊖ [Viking Tech](#) Information

## Optimize Your Supply Chain with WIN SOURCE Solutions

- ✓ Global Sourcing Solution
- ✓ Obsolete Management
- ✓ Cost Control Management
- ✓ Shortage Management
- ✓ Alternative Solution
- ✓ Excess Inventory Management