



**THE DATASHEET OF  
CZRA4731-HF**



## CZRA4728-HF Thru. CZRA4764-HF

Voltage: 3.3 to 100 Volts

Power: 1.0 Watts

RoHS Device

Halogen Free

### Features

- Batch process design, excellent power dissipation offers better reverse leakage current and thermal resistance.
- Standard zener voltage tolerance  $\pm 5\%$ .
- Low inductance.
- Low profile package.
- Built-in strain relief.

### Mechanical data

- Epoxy: UL94V-0 rated flame retardant.
- Case: Molded plastic, JEDEC DO-214AC/SMA
- Terminals: Solder Plated, solderable per MIL-STD-750, method 2026.
- Polarity: Indicated by cathode band.
- Mounting position: Any.
- Weight: 0.05 gram (approx.).

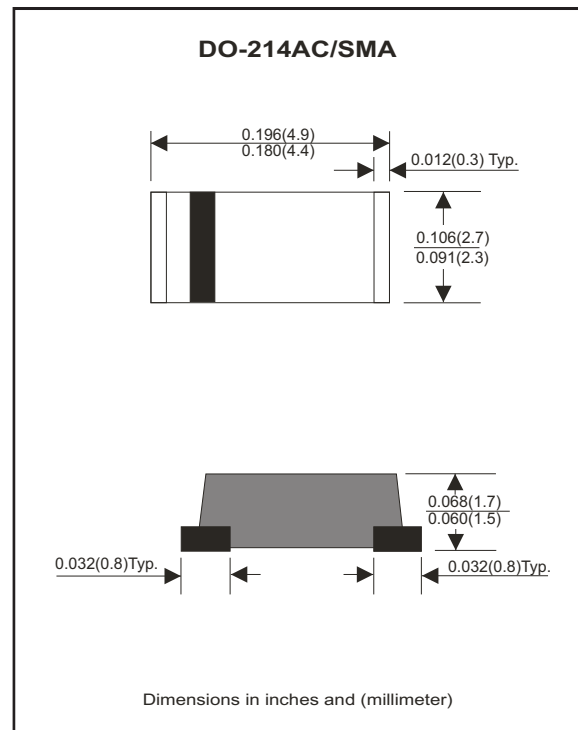

### Maximum Ratings (T<sub>A</sub>=25°C, unless otherwise noted)

Parameter	Condition	Symbol	MIN.	TYP.	MAX.	Units
Forward voltage	IF = 200 mA	V <sub>F</sub>			1.20	V
Power Dissipation	@TL = 75°C	P <sub>D</sub>			1000	mW
Thermal resistance	Junction to case (Note 1)	R <sub>θJC</sub>		30		°C/W
	Junction to ambient (Note 1)	R <sub>θJA</sub>		50		°C/W
Operating temperature		T <sub>J</sub>	-55		+150	°C
Storage temperature		T <sub>STG</sub>	-65		+175	°C

Note: 1. Mounted on 0.2"x0.2" (5x5mm) FR-4 PCB.

## Electrical Characteristics ( at TA = 25°C unless otherwise noted)

Part Number	Marking Code	Zener Voltage	Test Current	Zener Impedance			Leakage Current		Surge Current
		Vz@IzT	IzT	ZzT @ IzT	Zzk @ IzK	IzK	IR	VR	I <sub>surge</sub>
		Volts	mA	oHMs	oHMs	mA	uA	Volts	mA
CZRA4728-HF	Z3V3	3.3	76	10	400	1.0	100	1.0	1380
CZRA4729-HF	Z3V6	3.6	69	10	400	1.0	100	1.0	1260
CZRA4730-HF	Z3V9	3.9	64	9	400	1.0	50	1.0	1190
CZRA4731-HF	Z4V3	4.3	58	9	400	1.0	10	1.0	1070
CZRA4732-HF	Z4V7	4.7	53	8	500	1.0	10	1.0	970
CZRA4733-HF	Z5V1	5.1	49	7	550	1.0	10	1.0	890
CZRA4734-HF	Z5V6	5.6	45	5	600	1.0	10	2.0	810
CZRA4735-HF	Z6V2	6.2	41	2	700	1.0	10	3.0	730
CZRA4736-HF	Z6V8	6.8	37	3.5	700	1.0	10	4.0	660
CZRA4737-HF	Z7V5	7.5	34	4	700	0.5	10	5.0	605
CZRA4738-HF	Z8V2	8.2	31	4.5	700	0.5	10	6.0	550
CZRA4739-HF	Z9V1	9.1	28	5	700	0.5	10	7.0	500
CZRA4740-HF	Z10	10	25	7	700	0.25	10	7.6	454
CZRA4741-HF	Z11	11	23	8	700	0.25	5	8.4	414
CZRA4742-HF	Z12	12	21	9	700	0.25	5	9.1	380
CZRA4743-HF	Z13	13	19	10	700	0.25	5	9.9	344
CZRA4744-HF	Z15	15	17	14	700	0.25	5	11.4	304
CZRA4745-HF	Z16	16	15.5	16	700	0.25	5	12.2	285
CZRA4746-HF	Z18	18	14	20	750	0.25	5	13.7	250
CZRA4747-HF	Z20	20	12.5	22	750	0.25	5	15.2	225
CZRA4748-HF	Z22	22	11.5	23	750	0.25	5	16.7	205
CZRA4749-HF	Z24	24	10.5	25	750	0.25	5	18.2	190
CZRA4750-HF	Z27	27	9.5	35	750	0.25	5	20.6	170
CZRA4751-HF	Z30	30	8.5	40	1000	0.25	5	22.8	150
CZRA4752-HF	Z33	33	7.5	45	1000	0.25	5	25.1	135
CZRA4753-HF	Z36	36	7.0	50	1000	0.25	5	27.4	125
CZRA4754-HF	Z39	39	6.5	60	1000	0.25	5	29.7	115
CZRA4755-HF	Z43	43	6.0	70	1500	0.25	5	32.7	110

## Electrical Characteristics ( at $T_A = 25^\circ\text{C}$ unless otherwise noted)

Part Number	Marking Code	Zener Voltage	Test Current	Zener Impedance			Leakage Current		Surge Current
		$V_Z @ I_{ZT}$	$I_{ZT}$	$Z_{ZT} @ I_{ZT}$	$Z_{ZK} @ I_{ZK}$	$I_{ZK}$	$I_R$	$V_R$	$I_{surge}$
		Volts	mA	( $\Omega$ )Max	( $\Omega$ )Max	mA	( $\mu\text{A}$ )Max	Volts	mA
CZRA4756-HF	Z47	47	5.5	80	1500	0.25	5	35.8	95
CZRA4757-HF	Z51	51	5.0	95	1500	0.25	5	38.8	90
CZRA4758-HF	Z56	56	4.5	110	2000	0.25	5	42.6	80
CZRA4759-HF	Z62	62	4.0	125	2000	0.25	5	47.1	70
CZRA4760-HF	Z68	68	3.7	150	2000	0.25	5	51.7	65
CZRA4761-HF	Z75	75	3.3	175	2000	0.25	5	56.0	60
CZRA4762-HF	Z82	82	3.0	200	3000	0.25	5	62.2	55
CZRA4763-HF	Z91	91	2.8	250	3000	0.25	5	69.2	50
CZRA4764-HF	Z100	100	2.5	350	3000	0.25	5	76.0	45

Note: 5% tolerance of Zener voltage.

## RATING AND CHARACTERISTIC CURVES (CZRA4728-HF Thru. CZRA4764-HF)

Fig.1 - Max. Continuous Power Derating

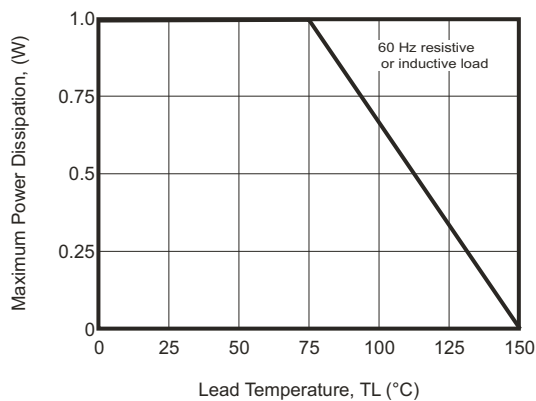
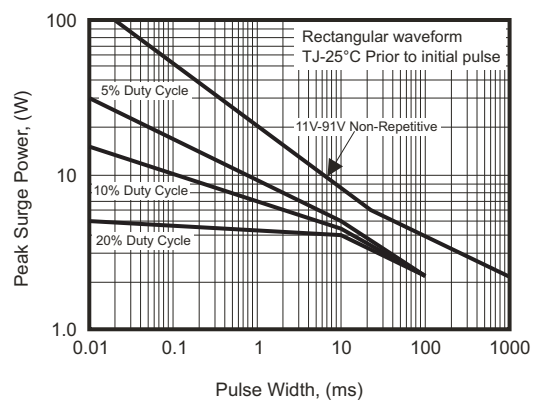

Fig.2 - Maximum surge power



## RATING AND CHARACTERISTIC CURVES (CZRA4728-HF Thru. CZRA4764-HF)

FIG 3A. Range for Units to 12 Volts

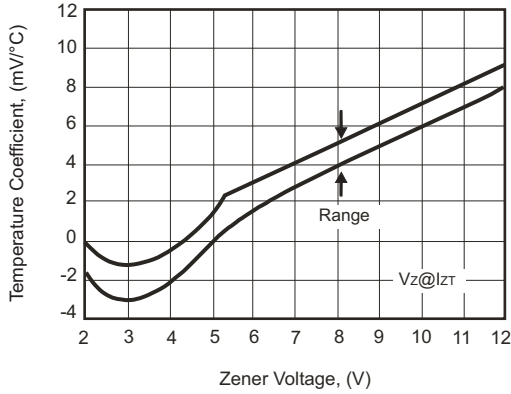

FIG 3B. Range for Units 12 to 100 Volts

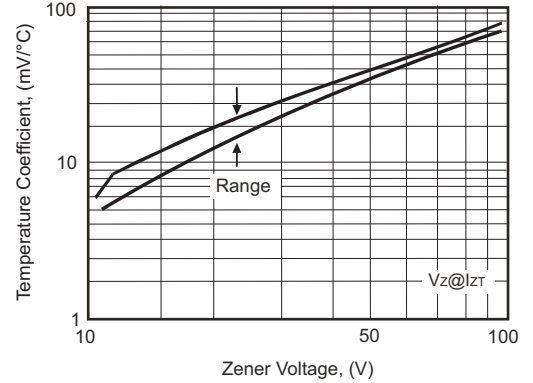

FIG 4. Temperature Coefficients (-55°C to +150°C temperature change ; 90% of the units are in the ranges indicated.)

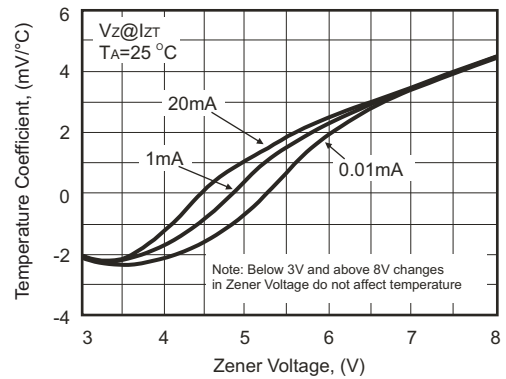
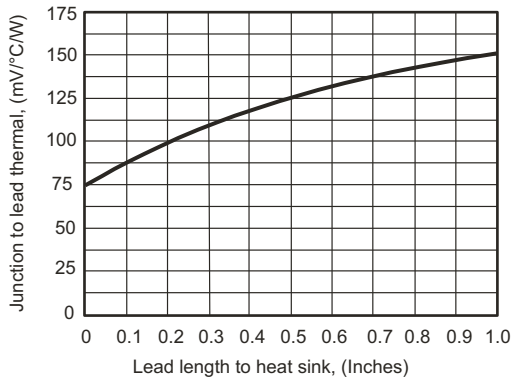

FIG 5. Typical Thermal Resistance Versus Lead

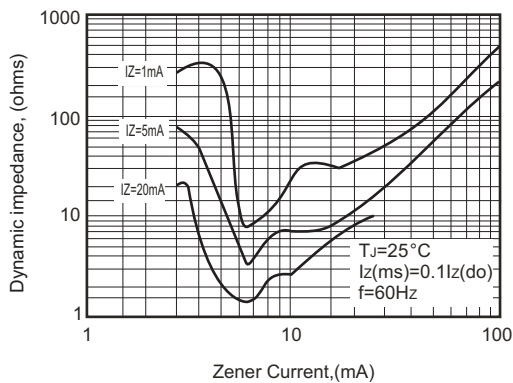
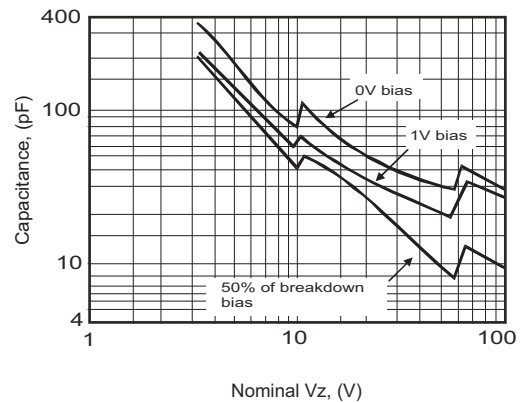
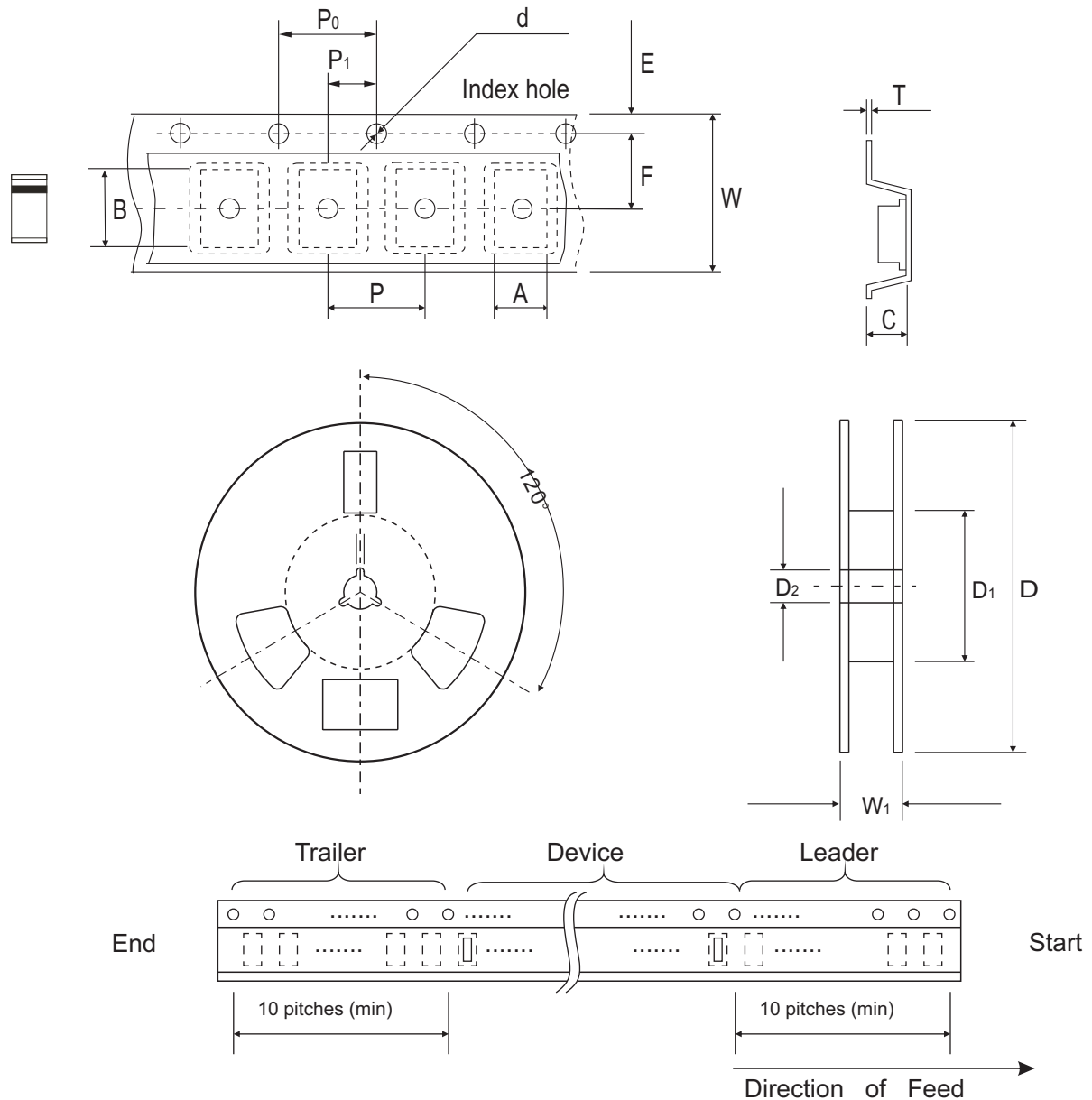

FIG 6. Effect of Zener Current



## Reel Taping Specification



DO-214AC (SMA)	SYMBOL	A	B	C	d	D	D1	D2
	(mm)	$2.8 \pm 0.10$	$5.00 \pm 0.10$	$1.90 \pm 0.10$	$1.50 \pm 0.10$	$178 \pm 2.00$	62.0 MIN.	$13.0 \pm 0.50$
	(inch)	$0.110 \pm 0.004$	$0.197 \pm 0.004$	$0.075 \pm 0.004$	$0.059 \pm 0.004$	$7.008 \pm 0.078$	2.441 MIN.	$0.512 \pm 0.008$

DO-214AC (SMA)	SYMBOL	E	F	P	P0	P1	W	W1
	(mm)	$1.75 \pm 0.10$	$5.50 \pm 0.10$	$4.00 \pm 0.10$	$4.00 \pm 0.10$	$2.00 \pm 0.10$	$12.00 \pm 0.30$	$18.00 \pm 1.00$
	(inch)	$0.069 \pm 0.004$	$0.217 \pm 0.002$	$0.157 \pm 0.004$	$0.157 \pm 0.004$	$0.079 \pm 0.004$	$0.472 \pm 0.012$	$0.709 \pm 0.040$

Company reserves the right to improve product design , functions and reliability without notice.

REV:C

## Pinning information

Pin	Simplified outline	Symbol
PIN 1 Cathode PIN 2 Anode		

## Marking Code

Part Number	Marking Code
CZRA4728-HF ~ CZRA4764-HF	XXXX



Product type marking code (see page.2~3)

## Suggested PAD Layout

SIZE	DO-214AC (SMA)	
	(mm)	(inch)
A	3.80	0.150
B	1.60	0.063
C	2.80	0.110
D	5.40	0.213
E	2.20	0.087

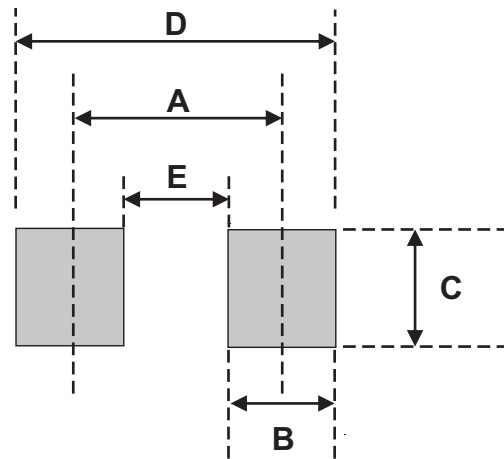



## Standard Packaging

Case Type	REEL PACK	
	REEL ( pcs )	Reel Size (inch)
DO-214AC (SMA)	2,000	7

## Looking for pricing, stock, or lifecycle information?

Click below to explore more details on WIN SOURCE:

-  [View CZRA4731-HF on WIN SOURCE](#)
-  [Comchip Technology Information](#)

## Optimize Your Supply Chain with WIN SOURCE Solutions

-  Global Sourcing Solution
-  Obsolete Management
-  Cost Control Management
-  Shortage Management
-  Alternative Solution
-  Excess Inventory Management