



**THE DATASHEET OF
BU8763FV-E2**



Melody LSI for Cellular Phone

BU8763FV

BU8763FV is a melody LSI for cellular phones that can produce triple chords simultaneously. Tone and volume in each sound source can be controlled separately by serial control. Master volume is integrated. Master clock can be selected from 5.376MHz or 2.688MHz. Output can be changed sine wave or special square wave. The special square wave is a waveform that can take sound pressure by even a small speaker.

●Applications

Melody sound at receiving or holding a call

●Features

- 1) Generating 3 waves, Controlled by CPU
- 2) Selectable master clock (5.376MHz / 2.688MHz)
- 3) Changeable parameter for wave generate
- 4) Including DTMF create function
- 5) Changeable Sine wave or special square wave
- 6) Serial control from CPU
- 7) Include smoothing filter ($f_c=20\text{KHz}$)
- 8) SSOP-B16 package

●Absolute maximum ratings (Ta=25°C)

Parameter	Symbol	Limits	Unit
Digital supply voltage	DVDD	-0.3 to +4.5	V
Analog supply voltage	AVDD	-0.3 to +4.5	V
Input voltage for digital	VD _{IN}	DVSS-0.3 to DVDD+0.3	V
Input voltage for analog	VA _{IN}	AVSS-0.3 to AVDD+0.3	V
Power dissipation	Pd	450*	mW
Storage temperature range	Tstg	-50 to +125	°C
Operating temperature range	Topr	-20 to +70	°C

* To use at temperature higher than 25°C, derate 4mW/°C, PCB(70mm×70mm, d=1.6mm glass epoxy)

Communications

●Block diagram

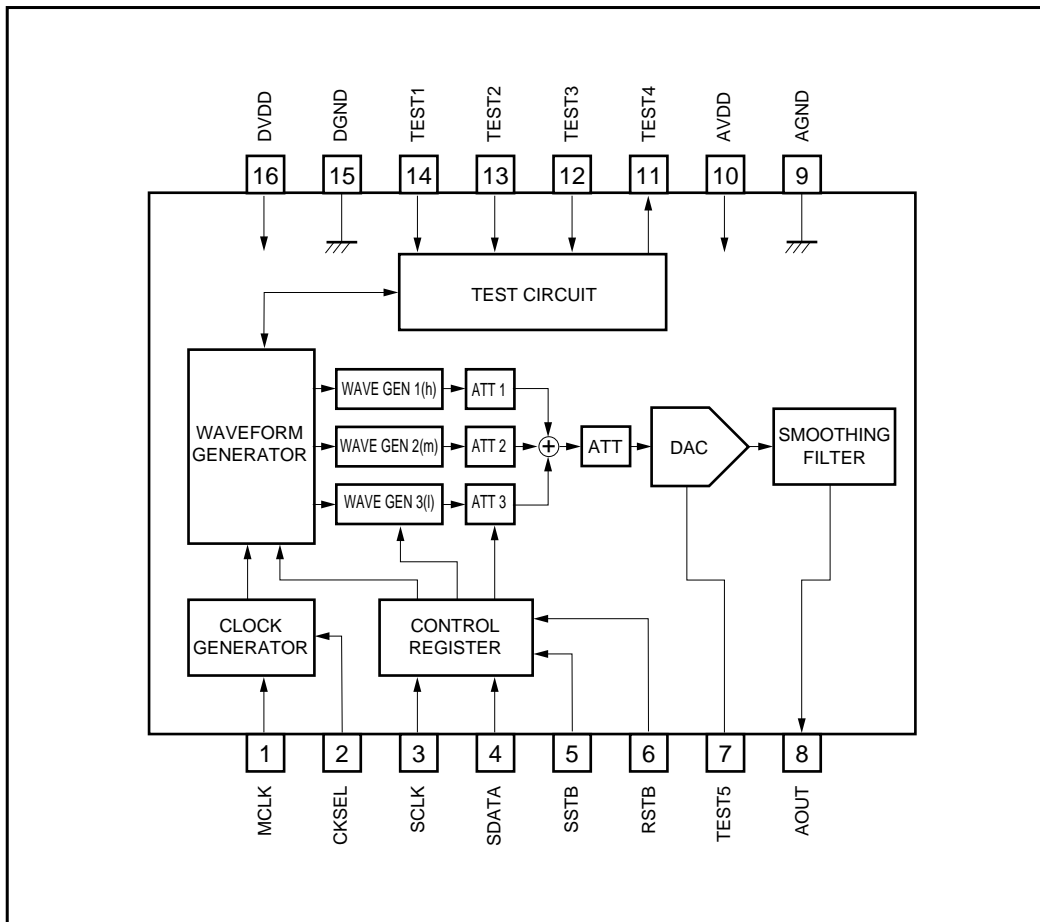

Communications

●Pin list

Pin No.	Pin name	Functions	I / O	Type	Circuit	Others
1	MCLK	Master clock input	I	CMOS	A	
2	CKSEL	Master clock select	I	CMOS	A	Hi : 2.688MHz, Lo : 5.376MHz
3	SCLK	Serial clock input	I	CMOS	A	
4	SDATA	Serial data input	I	CMOS	A	
5	SSTB	Serial strobe input	I	CMOS	A	
6	RSTB	Reset input	I	CMOS	A	Lo : Reset
7	TEST5	test pin	O	Analog	C	Do not connect
8	AOUT	Melody output pin	O	Analog	C	
9	AGND	Analog ground		PWR		
10	AVDD	Analog power supply		PWR		
11	TEST4	test pin	O	CMOS	B	Do not connect
12	TEST3	test pin	I	CMOS	A	Please connect to ground
13	TEST2	test pin	I	CMOS	A	Please connect to ground
14	TEST1	test pin	I	CMOS	A	Please connect to ground
15	DGND	Digital ground		PWR		
16	DVDD	Digital power supply		PWR		

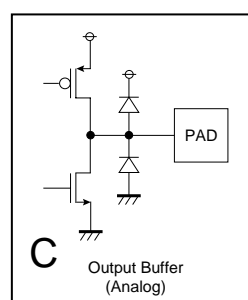
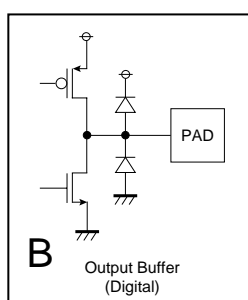
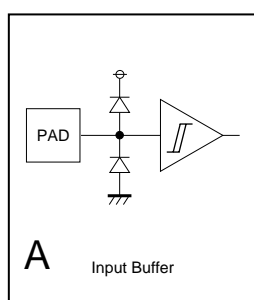

Communications

●Electrical characteristics

. Digital characteristics (Unless otherwise noted DVDD=AVDD=3.0V, Ta=25°C)

Parameter	Symbol	Min.	Typ.	Max.	Unit	Conditions
Digital power supply	DVDD	2.7	3.0	3.6	V	
Hi level input voltage	V _{IH}	2.5	–	–	V	
Low level input voltage	V _{IL}	–	–	0.5	V	
Hi level input current	I _{IH}	–	–	10	μA	
Low level input current	I _{IL}	–10	–	–	μA	
Hi level output voltage	V _{OH}	2.3	–	–	V	
Low level output voltage	V _{OL}	–	–	0.5	V	
MCLK input frequency 1	FMCLK1	–	5.376	–	MHz	CKSEL=Low
MCLK input frequency 2	FMCLK2	–	2.688	–	MHz	CKSEL=High
SCLK input frequency	FSCLK	–	–	3.0	MHz	
MCLK duty	DMCLK	40	50	60	%	
SCLK duty	DSCLK	40	50	60	%	
Data setup time	T _{sc}	200	–	–	ns	
Data hold time	T _{hc}	190	–	–	ns	
SCLK to SSTB width	T _{ss}	0.0	–	–	ns	
SSTB pulse width	T _{ds}	200	–	–	ns	
SSTB to SCLK width	T _{hs}	200	–	–	ns	

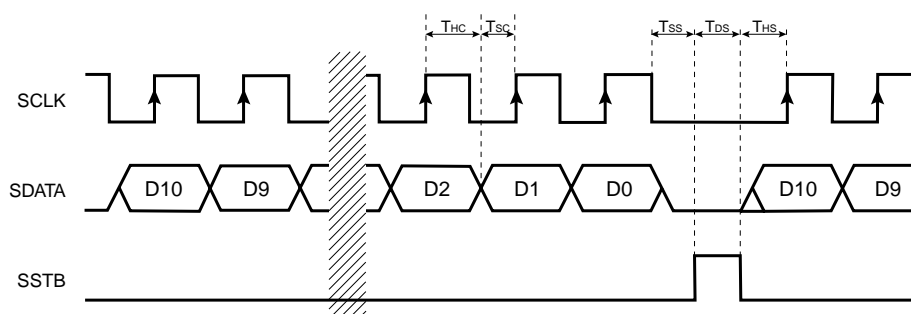

Address is upper 3bit in serial data, DATA is lower 8bit. (MSB first base)

SDATA is taken in to the inside with a positive edge SCLK, then SDATA is taken in to the register with a positive edge of SSTB.

In the case that the clock number of SCLK is 12 or more, the data of 11CLK of before SSTB comes into effect.

. Analog characteristics ((Unless otherwise noted DVDD=AVDD=3.0V, Ta=25°C)

Parameter	Symbol	Min.	Typ.	Max.	Unit	Conditions
Analog power supply	AVDD	2.7	3.0	3.6	V	AVDD-DVDD < 0.3V
Current consumption 1	I _{DD1}	–	–	2.0	μA	at sleep mode
Current consumption 2	I _{DD2}	–	1.2	2.5	mA	at operate mode
AOUT maximum output level (at 1 wave generator)	V _{OUT}	289.0	342.5	415.4	mVrms	ATT123=000, f=988KHz
Load resistor	R _{LOAD}	20	–	–	kΩ	
Load capacitance	C _{LOAD}	–	–	100	pF	

* Current consumption is sum of AVDD and DVDD.

Communications

●Circuit operation

Register map

< Data structure >

Address is upper 3bit in serial data, DATA is lower 8bit. (MSB first base)

Address			Data							
D10	D9	D8	D7	D6	D5	D4	D3	D2	D1	D0

Address			D7	D6	D5	D4	D3	D2	D1	D0
0	Operating	Data	WAVE1 on/off	WAVE2 on/off	WAVE3 on/off	TNSEL mode	FSEL MOL/MF	-	-	SLEEP
		Initial	0	0	0	0	0	0	0	1
1	Mode	Data	WMODE[1:0] WAVE GEN select		FLAVOR wave	ENVON on/off	ENVM time	ATT123[2:0] gain data		
		Initial	00		MLDY 0 DTMF 1	0	0	MLDY 1:001 2:100 3:000 DTMF 1:000 2:001 3:000		
2	Frequency	Data	WFEQ[1:0] WAVE GEN select		FREQ[5:0] frequency data					
		Initial	00		MLDY 1:000000 2:000000 3:000000 DTMF 1:000000 2:000100 3:001000					
3	Gain	Data	-	-	-	-	VOLUME[3:0]			
		Initial	0	0	0	0	0000			
4-7	Reserved									

Address 0 : Wave generator select, MELODY / DTMF setting

Address	Bit	Name	Initial	State
0	D7	WAVE1	0	WAVE1 control 0: output off 1: output on
	D6	WAVE2	0	WAVE2 control 0: output off 1: output on
	D5	WAVE3	0	WAVE3 control 0: output off 1: output on
	D4	TNSEL	0	Output select MELODY, DTMF/TONE 0: MELODY select 1: DTMF/TONE select
	D3	FSEL	0	Register select MELODY, DTMF/TONE 0: MELODY select 1: DTMF/TONE select
	D2-D1	Reserved	00	
	D0	SLEEP	1	Power down control 0: operating mode 1: power down mode

Communications

Address 1 : Mode setting

Address	Bit	Name	Initial	State			
1	D7-D6	WMOD[1:0]	00	Envelope ON, Envelope mode, generator attenuation 00: WAVE 1 01: WAVE 2 10: WAVE 3			
	D5	FLAVOR	MLDY:0 DTMF:1	Special square / sine wave 0: special square 1: sine wave (Same setting WAVE1,2,3)			
	D4	ENVON	0	Envelope ON/OFF 0: envelope OFF 1: envelope ON			
	D3	ENVM	0	Select envelope mode 0: for slow tempo 1.6sec 1: for high tempo 0.8sec			
	D2-D0	ATT123[2:0]	MLDY 1:001 2:100 3:000 DTMF 1:000 2:001 3:000	D2	D1	D0	Attenuation
			0	0	0	0dB	
			0	0	1	-2.5dB	
			0	1	0	-6.0dB	
			0	1	1	-8.5dB	
			1	0	0	-12.0dB	
			1	0	1	-14.5dB	
			1	1	0	-18.0dB	
			1	1	1	-24.0dB	

* Setting of D4-D0 is available for sound source selected at D7-D6.

Address 2 : Output frequency

Address	Bit	Name	Initial	State			
2	D7-D6	WFREQ[1:0]	00	Specified wave generator 00: select WAVE 1 generator 01: select WAVE 2 generator 10: select WAVE 3 generator			
	D5-D0	FREQ[5:0]	MLDY 1:000000 2:000000 3:000000 DTMF 1:000000 2:000100 3:001000	Address 0: MELODY setting @TNSEL=0 DTMF/TONE setting @TNSEL=1 see the following table about the output frequency			

* Setting of D5-D0 is available for sound source selected at D7-D6.

Communications

Output frequency in case MELODY

FREQ[5:0]	D5	D4	D3	D2	D1	D0	Scale	Typical Freq. [Hz]	Theoretic Freq. [Hz]	Error [%]
00h	0	0	0	0	0	0	A(la)	109.95	110.00	-0.05
01h	0	0	0	0	0	1	A#(la#)	116.50	116.54	-0.03
02h	0	0	0	0	1	0	B(si)	123.53	123.47	0.05
03h	0	0	0	0	1	1	C(do)	130.84	130.81	0.02
04h	0	0	0	1	0	0	C#(do#)	138.61	138.59	0.02
05h	0	0	0	1	0	1	D(le)	146.85	146.83	0.01
06h	0	0	0	1	1	0	D#(le#)	155.56	155.56	-0.01
07h	0	0	0	1	1	1	E(mi)	164.71	164.81	-0.07
08h	0	0	1	0	0	0	F(fa)	174.64	174.61	0.01
09h	0	0	1	0	0	1	F#(fa#)	185.02	185.00	0.01
0Ah	0	0	1	0	1	0	G(sol)	195.80	196.00	-0.10
0Bh	0	0	1	0	1	1	G#(sol#)	207.41	207.65	-0.12
0Ch	0	0	1	1	0	0	A(la)	219.90	220.00	-0.05
0Dh	0	0	1	1	0	1	A#(la#)	233.33	233.08	0.11
0Eh	0	0	1	1	1	0	B(si)	247.06	246.94	0.05
0Fh	0	0	1	1	1	1	C(do)	261.68	261.63	0.02
10h	0	1	0	0	0	0	C#(do#)	277.23	277.18	0.02
11h	0	1	0	0	0	1	D(le)	293.71	293.66	0.01
12h	0	1	0	0	1	0	D#(le#)	311.11	311.13	-0.01
13h	0	1	0	0	1	1	E(mi)	329.41	329.63	-0.07
14h	0	1	0	1	0	0	F(fa)	348.55	349.23	-0.19
15h	0	1	0	1	0	1	F#(fa#)	370.04	369.99	0.01
16h	0	1	0	1	1	0	G(sol)	392.52	392.00	0.13
17h	0	1	0	1	1	1	G#(sol#)	415.84	415.30	0.13
18h	0	1	1	0	0	0	A(la)	439.79	440.00	-0.05
19h	0	1	1	0	0	1	A#(la#)	466.67	466.16	0.11
1Ah	0	1	1	0	1	0	B(si)	494.12	493.88	0.05
1Bh	0	1	1	0	1	1	C(do)	523.36	523.25	0.02
1Ch	0	1	1	1	0	0	C#(do#)	554.46	554.37	0.02
1Dh	0	1	1	1	0	1	D(le)	587.41	587.33	0.01
1Eh	0	1	1	1	1	0	D#(le#)	622.22	622.25	-0.01
1Fh	0	1	1	1	1	1	E(mi)	658.82	659.26	-0.07
20h	1	0	0	0	0	0	F(fa)	697.10	698.46	-0.19
21h	1	0	0	0	0	1	F#(fa#)	740.09	739.99	0.01
22h	1	0	0	0	1	0	G(sol)	785.05	783.99	0.13
23h	1	0	0	0	1	1	G#(sol#)	831.68	830.61	0.13
24h	1	0	0	1	0	0	A(la)	879.58	880.00	-0.05
25h	1	0	0	1	0	1	A#(la#)	933.33	923.33	0.11
26h	1	0	0	1	1	0	B(si)	988.24	987.77	0.05
27h	1	0	0	1	1	1	C(do)	1046.73	1046.50	0.02
28h	1	0	1	0	0	0	C#(do#)	1108.91	1108.73	0.02
29h	1	0	1	0	0	1	D(le)	1174.83	1174.66	0.01
2Ah	1	0	1	0	1	0	D#(le#)	1244.44	1244.51	-0.01

Communications

FREQ[5:0]	D5	D4	D3	D2	D1	D0	Scale	Typical Freq. [Hz]	Theoretic Freq. [Hz]	Error [%]
2Bh	1	0	1	0	1	1	E(mi)	1317.65	1318.51	-0.07
2Ch	1	0	1	1	0	0	F(fa)	1394.19	1396.91	-0.19
2Dh	1	0	1	1	0	1	F#(fa#)	1480.18	1479.98	0.01
2Eh	1	0	1	1	1	0	G(sol)	1570.09	1567.98	0.13
2Fh	1	0	1	1	1	1	G#(sol#)	1663.37	1661.22	0.13
30h	1	1	0	0	0	0	A(la)	1759.16	1760.00	-0.05
31h	1	1	0	0	0	1	A#(la#)	1866.67	1864.66	0.11
32h	1	1	0	0	1	0	B(si)	1976.47	1975.53	0.05
33h	1	1	0	0	1	1	C(do)	2093.46	2093.00	0.02
34h	1	1	0	1	0	0	C#(do#)	2217.82	2217.46	0.02
35h	1	1	0	1	0	1	D(le)	2349.65	2349.32	0.01
36h	1	1	0	1	1	0	D#(le#)	2488.89	2489.02	-0.01
37h	1	1	0	1	1	1	E(mi)	2635.29	2637.02	-0.07
38h	1	1	1	0	0	0	F(fa)	2788.28	2793.83	-0.20
39h	1	1	1	0	0	1	F#(fa#)	2960.35	2959.96	0.01
3Ah	1	1	1	0	1	0	G(sol)	3140.19	3135.96	0.13
3Bh	1	1	1	0	1	1	G#(sol#)	3326.73	3322.44	0.13
3Ch	1	1	1	1	0	0	A(la)	3518.32	3520.00	-0.05
3Dh	1	1	1	1	0	1	A#(la#)	3733.33	3729.31	0.11
3Eh	1	1	1	1	1	0	B(si)	3952.94	3951.07	0.05
3Fh	1	1	1	1	1	1	C(do)	4173.91	4186.01	-0.29

Output frequency in case DTMF/TONE

FREQ[5:0]	D5	D4	D3	D2	D1	D0	WAVE	Scale	Typical Freq. [Hz]	Theoretic Freq. [Hz]	Error [%]
00h	0	0	0	0	0	0	WAVE_1	DTMF_H	1208.63	1209.00	-0.03
01h	0	0	0	0	0	1	WAVE_1	DTMF_H	1333.33	1336.00	-0.20
02h	0	0	0	0	1	0	WAVE_1	DTMF_H	1473.68	1477.00	-0.22
03h	0	0	0	0	1	1	WAVE_1	DTMF_H	1631.07	1633.00	-0.12
04h	0	0	0	1	0	0	WAVE_2	DTMF_L	697.10	697.00	0.01
05h	0	0	0	1	0	1	WAVE_2	DTMF_L	770.64	770.00	0.08
06h	0	0	0	1	1	0	WAVE_2	DTMF_L	852.79	852.00	0.09
07h	0	0	0	1	1	1	WAVE_2	DTMF_L	938.55	941.00	-0.26
08h	0	0	1	0	0	0	WAVE_3	TONE	383.56		
09h	0	0	1	0	0	1	WAVE_3	TONE	400.00		
0Ah	0	0	1	0	1	0	WAVE_3	TONE	1000.00		
0Bh	0	0	1	0	1	1	WAVE_3	TONE	1473.68		
0Ch	0	0	1	1	0	0	WAVE_3	TONE	2000.00		
0Dh	0	0	1	1	0	1	WAVE_3	TONE	2545.45		
0Eh	0	0	1	1	1	0	WAVE_3	TONE	4000.00		

* Even when more than 0Fh is set, it's not changed.

Communications

Address 3: Gain

Address	Bit	Name	Initial	State				
				D3	D2	D1	D0	ATT
3	D7-D4	reserved	0000					
	D3-D0	VOLUME	0000	0	0	0	0	0dB
				0	0	0	1	-2dB
				0	0	1	0	-4dB
				0	0	1	1	-6dB
				0	1	0	0	-8dB
				0	1	0	1	-10dB
				0	1	1	0	-12dB
				0	1	1	1	-14dB
				1	0	0	0	Reserved
				1	0	0	1	Reserved
				1	0	1	0	Reserved
				1	0	1	1	Reserved
				1	1	0	0	Reserved
				1	1	0	1	Reserved
				1	1	1	0	Reserved
				1	1	1	1	Reserved

Communications

●Application example

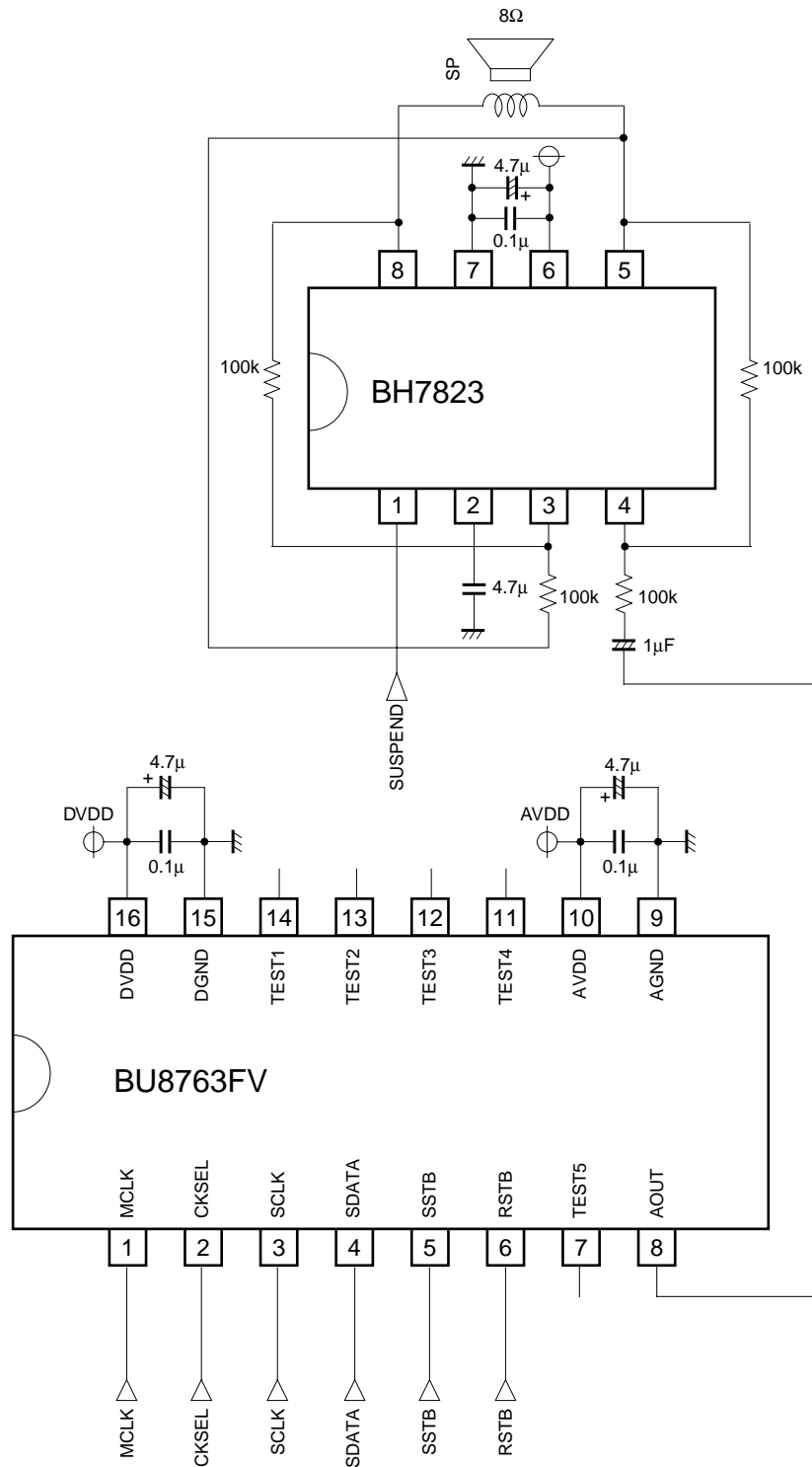

Fig.1

Communications

●Note for use

- 1) WAVE1, WAVE2, WAVE3 register, ATT123 register (at melody output), ATT register, ENVON register are changed when output is a zero cross.
- 2) FREQ [5:0] register is changed instantaneously.
- 3) In the case that unsound part is set up WAVE 1,2,3 register, wave is stopped with a zero cross. when it changes FREQ[5:0] before becoming off with a zero cross, new frequency wave output one cycle. After wait for to do off with a zero cross, change FREQ[5:0].
- 4) 3 sound resources can only the setting of all sine wave or all special square wave.
- 5) 3 sound resources can only the setting of all DTMF/TONE or all MELODY.
- 6) A data value of registration etc. is held at the time of SLEEP.
- 7) At the time of RESET, a data value of registration etc. becomes initial value.
- 8) Maximum output level (ATT=0dB) of one sound resource is 342.5mVrms (typ).
Set up each ATT123 sol that output levels of totals 3 sound resources does not exceed, because a maximum output level of DAC is $2.00V_{PP}$ (707.1mVrms).
- 9) TNSSEL of address 0 D4 is a setting register about whether output which of DTMF or MELODY.
- 10) FSEL of address 0 D3 is a setting register about whether make the setting of FREQ etc. which of DTMF or MELODY.

●External dimensions (Unit : mm)

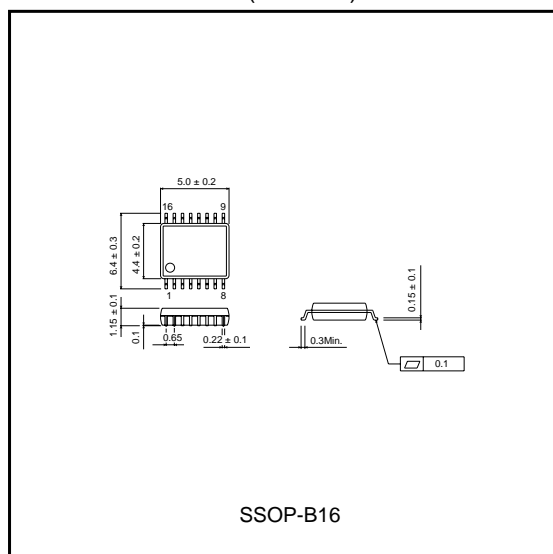

Notes

- No technical content pages of this document may be reproduced in any form or transmitted by any means without prior permission of ROHM CO.,LTD.
- The contents described herein are subject to change without notice. The specifications for the product described in this document are for reference only. Upon actual use, therefore, please request that specifications to be separately delivered.
- Application circuit diagrams and circuit constants contained herein are shown as examples of standard use and operation. Please pay careful attention to the peripheral conditions when designing circuits and deciding upon circuit constants in the set.
- Any data, including, but not limited to application circuit diagrams information, described herein are intended only as illustrations of such devices and not as the specifications for such devices. ROHM CO.,LTD. disclaims any warranty that any use of such devices shall be free from infringement of any third party's intellectual property rights or other proprietary rights, and further, assumes no liability of whatsoever nature in the event of any such infringement, or arising from or connected with or related to the use of such devices.
- Upon the sale of any such devices, other than for buyer's right to use such devices itself, resell or otherwise dispose of the same, no express or implied right or license to practice or commercially exploit any intellectual property rights or other proprietary rights owned or controlled by
- ROHM CO., LTD. is granted to any such buyer.
- Products listed in this document use silicon as a basic material.
Products listed in this document are no antiradiation design.

The products listed in this document are designed to be used with ordinary electronic equipment or devices (such as audio visual equipment, office-automation equipment, communications devices, electrical appliances and electronic toys).

Should you intend to use these products with equipment or devices which require an extremely high level of reliability and the malfunction of which would directly endanger human life (such as medical instruments, transportation equipment, aerospace machinery, nuclear-reactor controllers, fuel controllers and other safety devices), please be sure to consult with our sales representative in advance.

About Export Control Order in Japan

Products described herein are the objects of controlled goods in Annex 1 (Item 16) of Export Trade Control Order in Japan.

In case of export from Japan, please confirm if it applies to "objective" criteria or an "informed" (by MITI clause) on the basis of "catch all controls for Non-Proliferation of Weapons of Mass Destruction.

Looking for pricing, stock, or lifecycle information?

Click below to explore more details on WIN SOURCE:

- [View BU8763FV-E2 on WIN SOURCE](#)
- [Rohm Semiconductor Information](#)

Optimize Your Supply Chain with WIN SOURCE Solutions

- ✓ Global Sourcing Solution
- ✓ Obsolete Management
- ✓ Cost Control Management
- ✓ Shortage Management
- ✓ Alternative Solution
- ✓ Excess Inventory Management