

LVDS Interface ICs

35bit LVDS Transmitter

35:5 Serializer



BU8254KVT

No.13057ECT06

●Description

LVDS Interface IC of ROHM "Serializer" "Deserializer" operate from 8MHz to 150MHz wide clock range, and number of bits range is from 35 to 70. Data is transmitted seven times (7X) stream and reduce cable number by 3(1/3) or less. The ROHM's LVDS has low swing mode to be able to expect further low EMI.

●Features

- 1) 35bits data of parallel LVCMOS level inputs are converted to five channels of LVDS data stream.
- 2) 30bits of RGB data and 5bits of timing and control data(HSYNC, VSYNC, DE, CNTL1, CNTL2) are transmitted up to 784Mbps effective rate per LVDS channel.
- 3) Support clock frequency from 8MHz up to 112MHz.
- 4) Support consumer video format including 480i, 480P, 720P and 1080i as well.
- 5) Clock edge selectable
- 6) Power down mode
- 7) Support spread spectrum clock generator.
- 8) Support reduced swing LVDS for low EMI.
- 9) 30bit LVDS receiver is recommended to use BU90R104.

●Applications

Flat Panel Display

●Precaution

- This chip is not designed to protect from radioactivity.
- The chip is made strictly for the specific application or equipment.
Then it is necessary that the unit is measured as need.
- This document may be used as strategic technical data which subjects to COCOM regulations.

●Block Diagram

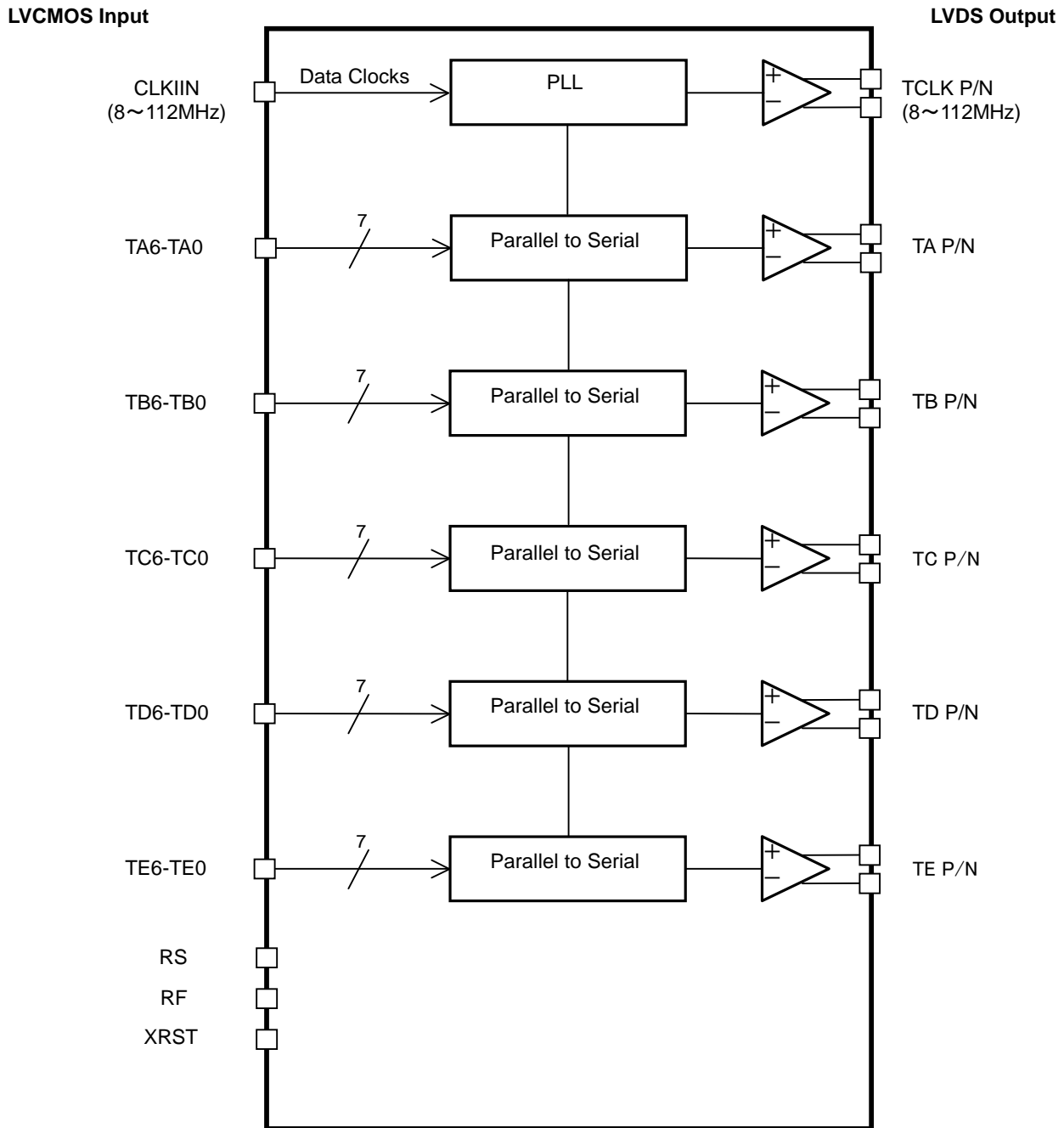

Fig.1 Block Diagram

●TQFP64V Package Outline and Specification

TQFP64V

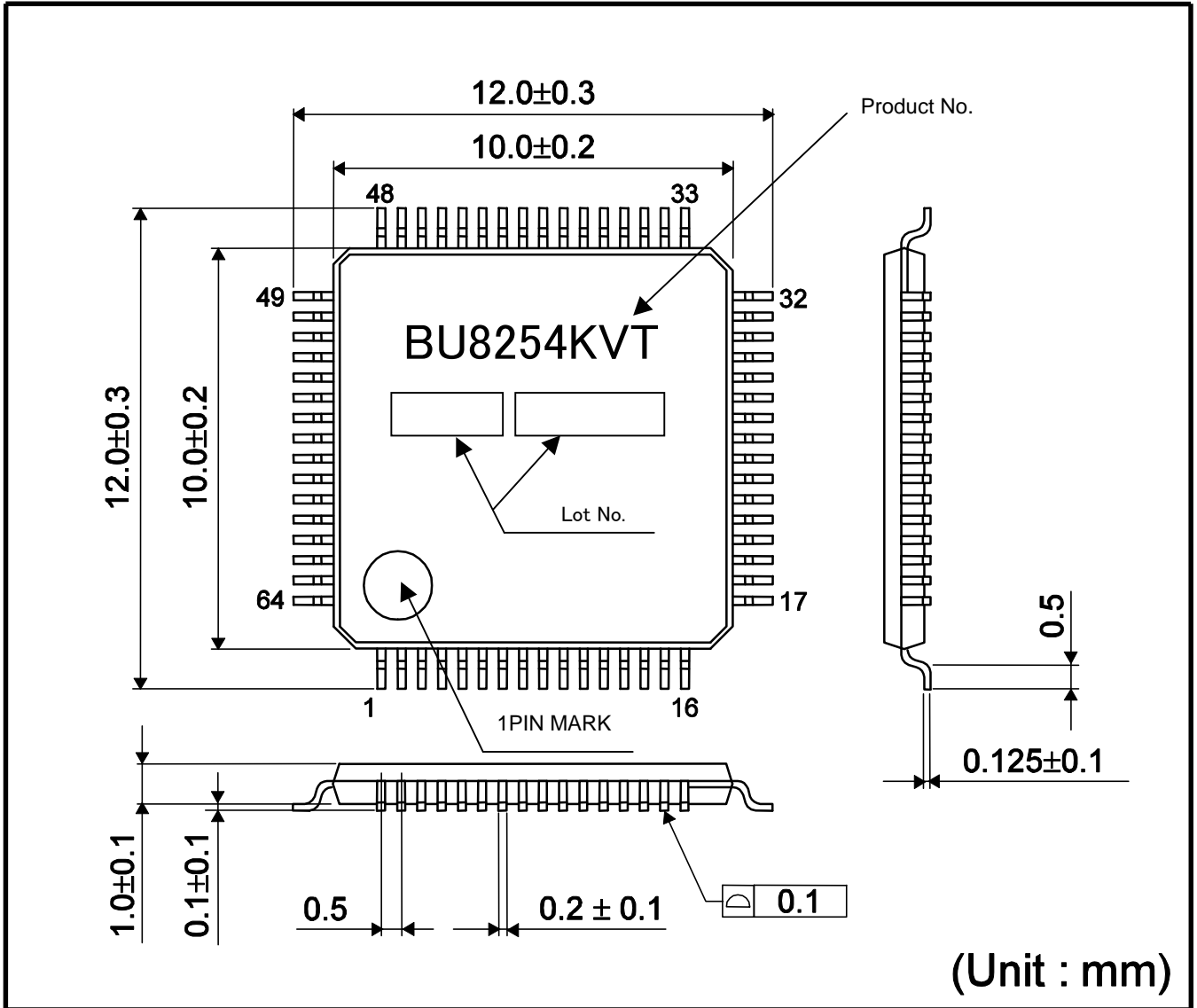

Fig.2 TQFP64V Package Outline and Specification

● Pin configuration

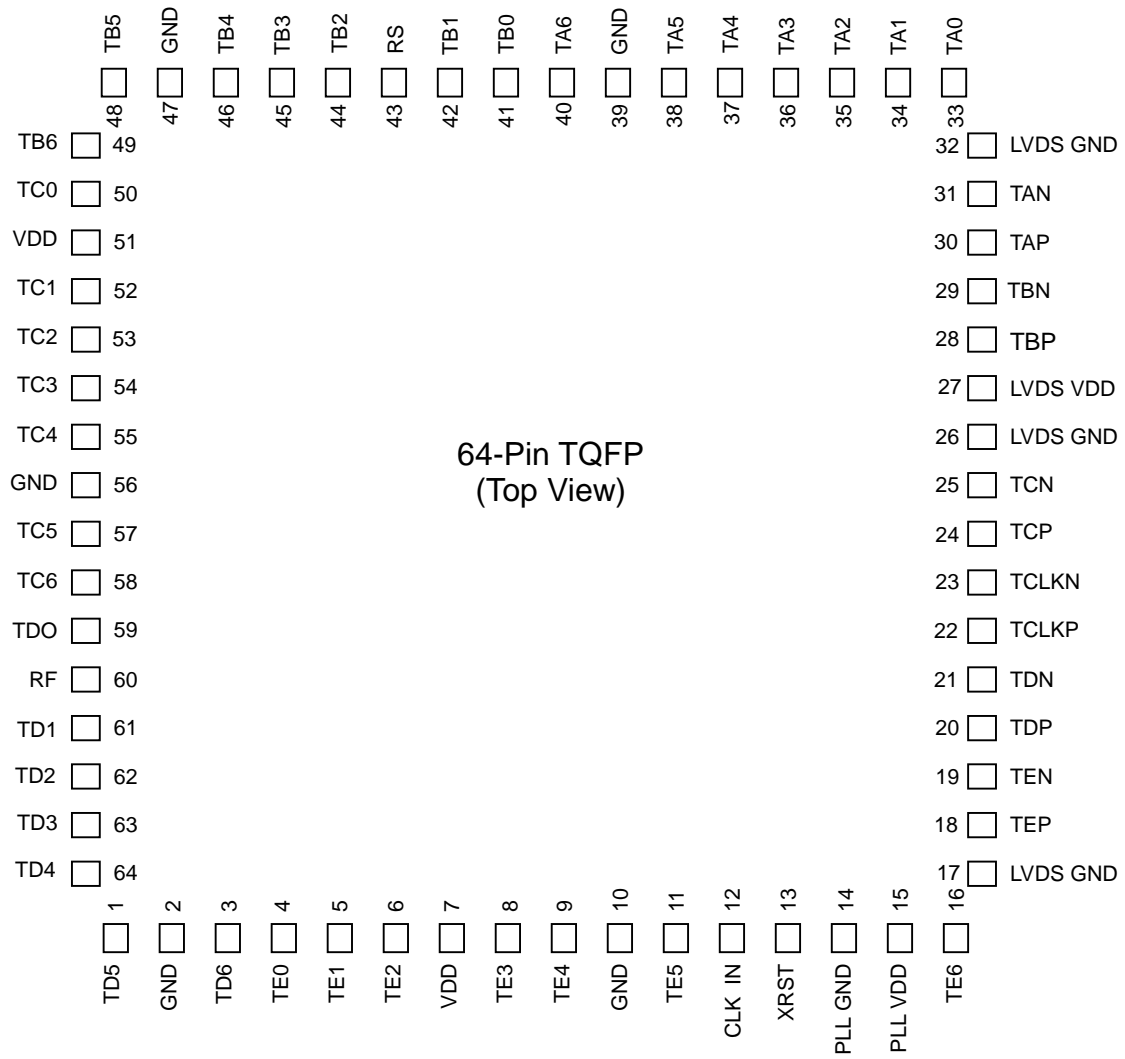

Fig.3 Pin Diagram (Top View)

● Pin Description

Table 1 : Pin Description

| Pin Name | Pin No. | Type | Descriptions | | | | | | | | | | | | |
|--|----------------------|---------------|--|--|---------------------------|---------------------------|----------|-------|-----|----------|-------|---------------|-----|-------|-----|
| TAP, TAN | 30,31 | LVDS OUT | LVDS data out. | | | | | | | | | | | | |
| TBP, TBN | 28,29 | LVDS OUT | | | | | | | | | | | | | |
| TCP, TCN | 24,25 | LVDS OUT | | | | | | | | | | | | | |
| TDP, TDN | 20,21 | LVDS OUT | | | | | | | | | | | | | |
| TEP, TEN | 18,19 | LVDS OUT | | | | | | | | | | | | | |
| TCLKP, TCLKN | 22,23 | LVDS OUT | | LVDS clock out. | | | | | | | | | | | |
| TA0~TA6 | 33,34,35,36,37,38,40 | IN | Pixel data inputs. | | | | | | | | | | | | |
| TB0~TB6 | 41,42,44,45,46,48,49 | IN | | | | | | | | | | | | | |
| TC0~TC6 | 50,52,53,54,55,57,58 | IN | | | | | | | | | | | | | |
| TD0~TD6 | 59,61,62,63,64,1,3 | IN | | | | | | | | | | | | | |
| TE0~TE6 | 4,5,6,8,9,11,16 | IN | | | | | | | | | | | | | |
| XRST | 13 | IN | | H : Normal operation, L : Power down (all outputs are Hi-Z) | | | | | | | | | | | |
| RS | 43 | IN | LVDS swing mode, V_{REF}^{*1} select. | | | | | | | | | | | | |
| | | | <table border="1"> <thead> <tr> <th>RS</th> <th>LVDS Swing</th> <th>Small Swing Input Support</th> </tr> </thead> <tbody> <tr> <td>V_{DD}</td> <td>350mV</td> <td>N/A</td> </tr> <tr> <td>0.6~1.4V</td> <td>350mV</td> <td>RS-V_{REF}</td> </tr> <tr> <td>GND</td> <td>200mV</td> <td>N/A</td> </tr> </tbody> </table> | RS | LVDS Swing | Small Swing Input Support | V_{DD} | 350mV | N/A | 0.6~1.4V | 350mV | RS- V_{REF} | GND | 200mV | N/A |
| | | | RS | LVDS Swing | Small Swing Input Support | | | | | | | | | | |
| | | | V_{DD} | 350mV | N/A | | | | | | | | | | |
| 0.6~1.4V | 350mV | RS- V_{REF} | | | | | | | | | | | | | |
| GND | 200mV | N/A | | | | | | | | | | | | | |
| *1 V_{REF} is Input Reference Voltage. | | | | | | | | | | | | | | | |
| RF | 60 | IN | Input clock triggering edge select. H : Rising edge, L : Falling edge. | | | | | | | | | | | | |
| VDD | 51,7 | Power | Power supply pins for LVCMOS inputs and digital core. | | | | | | | | | | | | |
| CLKIN | 12 | IN | Clock input. | | | | | | | | | | | | |
| GND | 2,10,39,47,56 | Ground | Ground pins for LVCMOS inputs and digital core. | | | | | | | | | | | | |
| LVDS VDD | 27 | Power | Power supply pins for LVDS outputs. | | | | | | | | | | | | |
| LVDS GND | 17,26,32 | Ground | Ground pins for LVDS outputs. | | | | | | | | | | | | |
| PLLVD | 15 | Power | Power supply pin for PLL core. | | | | | | | | | | | | |
| PLLGND | 14 | Ground | Ground pins for PLL core. | | | | | | | | | | | | |

●Electrical characteristics

■Rating

Table 2 : Absolute Maximum Ratings

| Parameter | Symbol | Ratings | | Units |
|---------------------------|------------------|---------|----------------------|-------|
| | | Min | Max | |
| Supply Voltage | V _{DD} | -0.3 | 4.0 | V |
| Input Voltage | V _{IN} | -0.3 | V _{DD} +0.3 | V |
| Output Voltage | V _{OUT} | -0.3 | V _{DD} +0.3 | V |
| Storage Temperature Range | T _{stg} | -55 | 125 | °C |

Table 3 : Package Power

| PACKAGE | Power Dissipation (mW) | De-rating (mW/°C) *1 |
|---------|------------------------|----------------------|
| TQFP64V | 700 | 7.0 |
| | 1000*2 | 10.0*2 |

*1: At temperature Ta >25°C

*2: Package power when mounting on the PCB board.

The size of PCB board :70 × 70 × 1.6(mm³)

The material of PCB board :The FR4 glass epoxy board.(3% or less copper foil area)

(It is recommended to apply the above package power requirement to PCB board when the small swing input mode is used)

Table 4 : Recommended Operating Conditions

| Parameter | Symbol | Ratings | | | Units | Conditions |
|-----------------------------|-----------------|---------|-----|-----|-------|--|
| | | Min | Typ | Max | | |
| Supply Voltage | V _{DD} | 3.0 | 3.3 | 3.6 | V | VDD,LVDSVDD,PLLVD |
| Operating Temperature Range | Topr | -40 | - | 85 | °C | Clock frequency from 8MHz up to 90MHz |
| | | 0 | - | 70 | °C | Cock frequency from 90MHz up to 112MHz |

■ DC characteristics

Table 5 : LVCMOS DC Specifications (VDD=3.0V~3.6V, Ta=-40°C~85°C)

| Parameter | Symbol | Rating | | | Units | Conditions |
|--------------------------------------|--------------------------------|----------------------------|---------------------|----------------------------|-------|--|
| | | Min | Typ | Max | | |
| High Level Input Voltage | V _{IH} | V _{DD} × 0.8 | - | V _{DD} | V | exclude RS pin |
| Low Level Input Voltage | V _{IL} | GND | - | V _{DD} × 0.2 | V | |
| High Level Input Voltage | V _{IHRS} | V _{DD} × 0.8 | - | V _{DD} | | RS pin |
| Low Level Input Voltage | V _{ILRS} | GND | - | 0.2 | | |
| Small Swing Voltage | V _{DDQ} ^{*1} | 1.2 | - | 2.8 | V | |
| Input Reference Voltage | V _{REF} | - | V _{DDQ} /2 | - | - | Small Swing(RS=V _{DDQ} /2) |
| Small Swing High Level Input Voltage | V _{SH} ^{*2} | V _{DDQ} /2 +200mV | - | - | V | V _{REF} =V _{DDQ} /2 |
| Small Swing Low Level Input Voltage | V _{SL} ^{*2} | - | - | V _{DDQ} /2 -200mV | V | V _{REF} =V _{DDQ} /2 |
| Input Current | I _{INC} | - | - | ±10 | μA | 0V ≤ V _{IN} ≤ V _{DD} |

*1: V_{DDQ} voltage defines max voltage of small swing input. It is not an actual input voltage.

*2: Small swing signal is applied to TA[6:0], TB[6:0], TC[6:0], TD[6:0], TE[6:0], CLKIN.

Table 6 : LVDS Transmitter DC Specifications(VDD=3.0V~3.6V, Ta=-40°C~85°C)

| Parameter | Symbol | Rating | | | Units | Conditions | |
|---|------------------|--------|------|-------|-------|---|--|
| | | Min | Typ | Min | | RL=100Ω | |
| Differential Output Voltage | V _{OD} | 250 | 350 | 450 | mV | | |
| | | 100 | 200 | 300 | mV | Reduced swing RS=GND | |
| Change in VOD between complementary output states | ΔV _{OD} | - | - | 35 | mV | RL=100Ω | |
| Common Mode Voltage | V _{OC} | 1.125 | 1.25 | 1.375 | V | | |
| Change in VOC between complementary output states | ΔV _{OC} | - | - | 35 | mV | | |
| Output Short Circuit Current | I _{OS} | - | - | -24 | mA | V _{OUT} =0V, RL=100Ω | |
| Output TRI-STATE Current | I _{OZ} | - | - | ±10 | μA | XRST=0V, V _{OUT} =0V to V _{DD} | |

■ Supply Current

Table 7 : Supply Current

| Parameter | Symbol | Rating | | | Units | Conditions | |
|---------------------------------------|-------------------|--------|-----|-----|-------|--|---------|
| | | Min | Typ | Max | | | |
| Transmitter Supply Current | I _{TCCG} | - | 57 | - | mA | RL=100Ω,CL=5pF V _{DD} =3.3V,RS=V _{DD} Gray Scale Pattern | f=85MHz |
| | | - | 42 | - | mA | RL=100Ω,CL=5pF V _{DD} =3.3V,RS=GND Gray Scale Pattern | f=85MHz |
| Transmitter Supply Current | I _{TCCW} | - | 62 | - | mA | RL=100Ω,CL=5pF V _{DD} =3.3V,RS=V _{DD} Worst Case pattern | f=85MHz |
| | | - | 45 | - | mA | RL=100Ω,CL=5pF V _{DD} =3.3V,RS=GND Worst Case pattern | f=85MHz |
| Transmitter Power Down Supply Current | I _{TCCS} | - | - | 10 | μA | XRST=L | |

Gray Scale Pattern

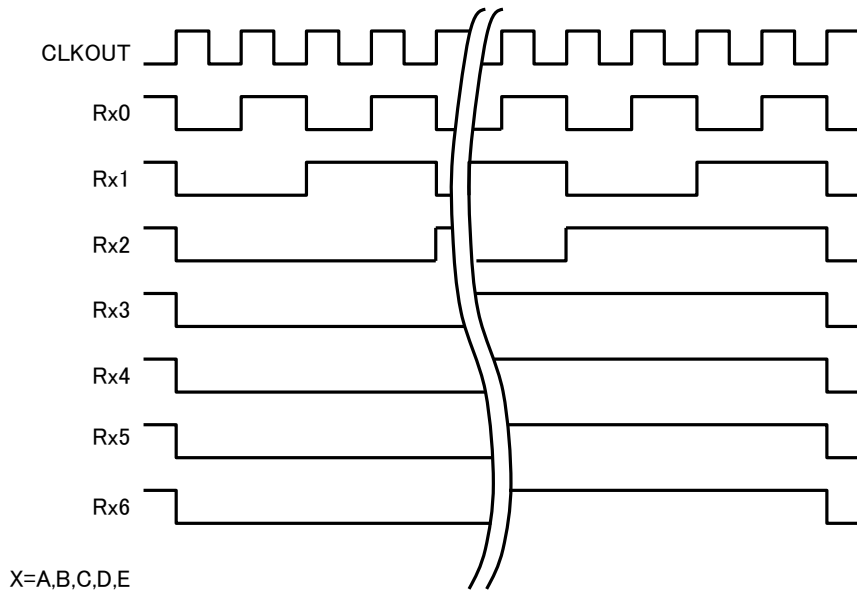

Fig.4 Gray scale pattern

Worst Case Pattern (Maximum Power condition)

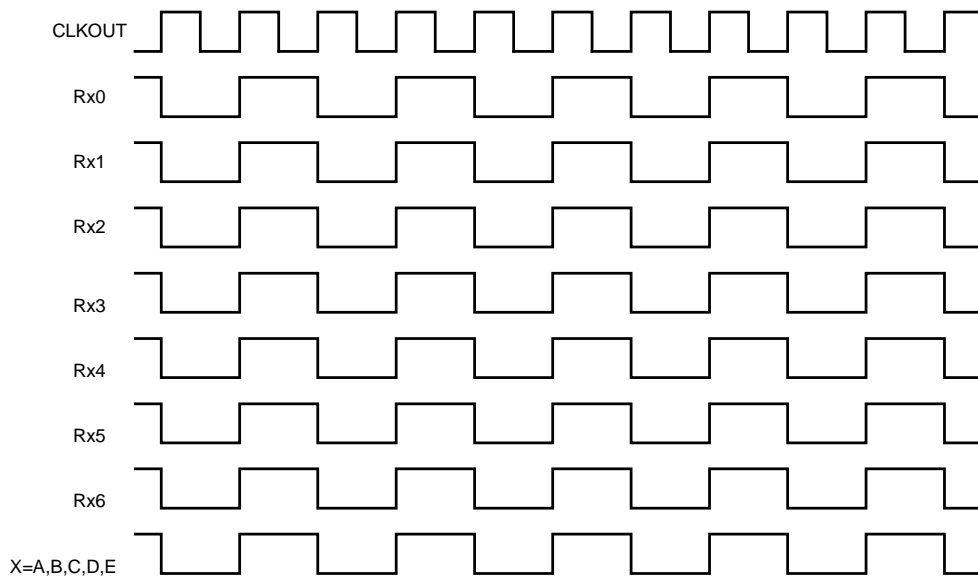

Fig.5 Worst Case Pattern

■ AC characteristics

Table 8 : Switching Characteristics

| Parameter | Symbol | Min | Typ | Max | Units |
|-------------------------------|------------|-----------------------------|-----------------------|-----------------------------|-------|
| CLK IN Transition time | t_{TClT} | - | - | 5.0 | ns |
| CLK IN Period | t_{TCP} | 8.93 | - | 125.0 | ns |
| CLK IN High Time | t_{TCH} | $0.35t_{TCP}$ | $0.5t_{TCP}$ | $0.65t_{TCP}$ | ns |
| CLK IN Low Time | t_{TCL} | $0.35t_{TCP}$ | $0.5t_{TCP}$ | $0.65t_{TCP}$ | ns |
| CLK IN to TCLK+/-Delay | t_{TCD} | - | t_{TCP} | - | ns |
| LVS MOS Data Set up to CLK IN | t_{TS} | 2.5 | - | - | ns |
| LVC MOS Data Hold from CLK IN | t_{TH} | 0 | - | - | ns |
| LVDS Transition Time | t_{LVT} | - | 0.6 | 1.5 | ns |
| Output Data Position 0 | t_{TOP1} | -0.2 | 0.0 | +0.2 | ns |
| Output Data Position 1 | t_{TOP0} | $\frac{t_{TCP}}{7} - 0.2$ | $\frac{t_{TCP}}{7}$ | $\frac{t_{TCP}}{7} + 0.2$ | ns |
| Output Data Position 2 | t_{TOP6} | $2 \frac{t_{TCP}}{7} - 0.2$ | $2 \frac{t_{TCP}}{7}$ | $2 \frac{t_{TCP}}{7} + 0.2$ | ns |
| Output Data Position 3 | t_{TOP5} | $3 \frac{t_{TCP}}{7} - 0.2$ | $3 \frac{t_{TCP}}{7}$ | $3 \frac{t_{TCP}}{7} + 0.2$ | ns |
| Output Data Position 4 | t_{TOP4} | $4 \frac{t_{TCP}}{7} - 0.2$ | $4 \frac{t_{TCP}}{7}$ | $4 \frac{t_{TCP}}{7} + 0.2$ | ns |
| Output Data Position 5 | t_{TOP3} | $5 \frac{t_{TCP}}{7} - 0.2$ | $5 \frac{t_{TCP}}{7}$ | $5 \frac{t_{TCP}}{7} + 0.2$ | ns |
| Output Data Position 6 | t_{TOP2} | $6 \frac{t_{TCP}}{7} - 0.2$ | $6 \frac{t_{TCP}}{7}$ | $6 \frac{t_{TCP}}{7} + 0.2$ | ns |
| Phase Locked Loop Set Time | t_{TPLL} | - | - | 10.0 | ms |

● AC Timing

■ AC Timing Diagrams

LVC MOS Input

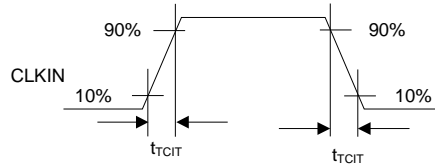

LVC MOS Output

LVDS Output

$$V_{diff} = (TAP) - (TAN)$$

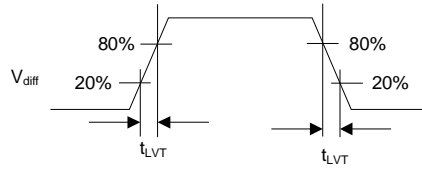
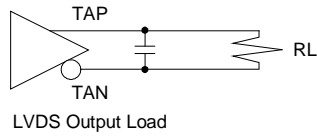

LVC MOS Input

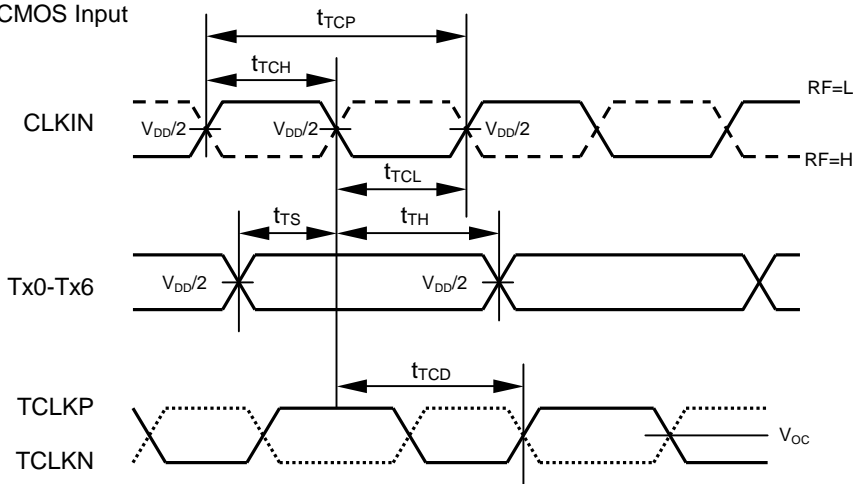

Fig.6 AC Timing Diagrams

■ Small Swing Inputs

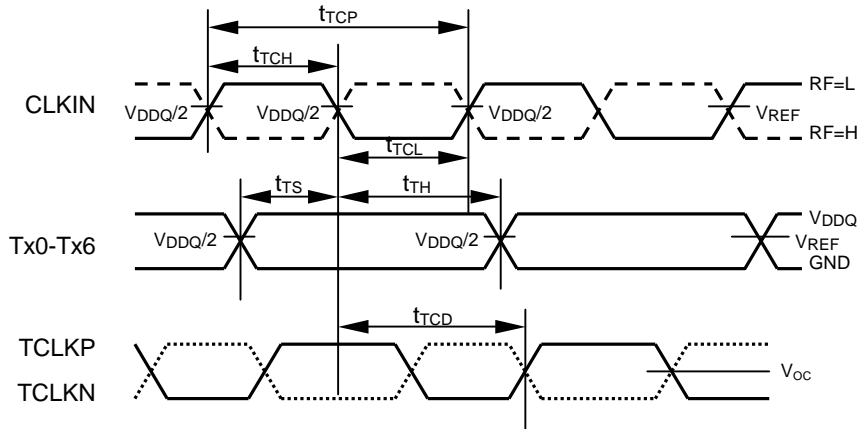

Fig.7 Small Swing Inputs

■ AC Timing Diagrams

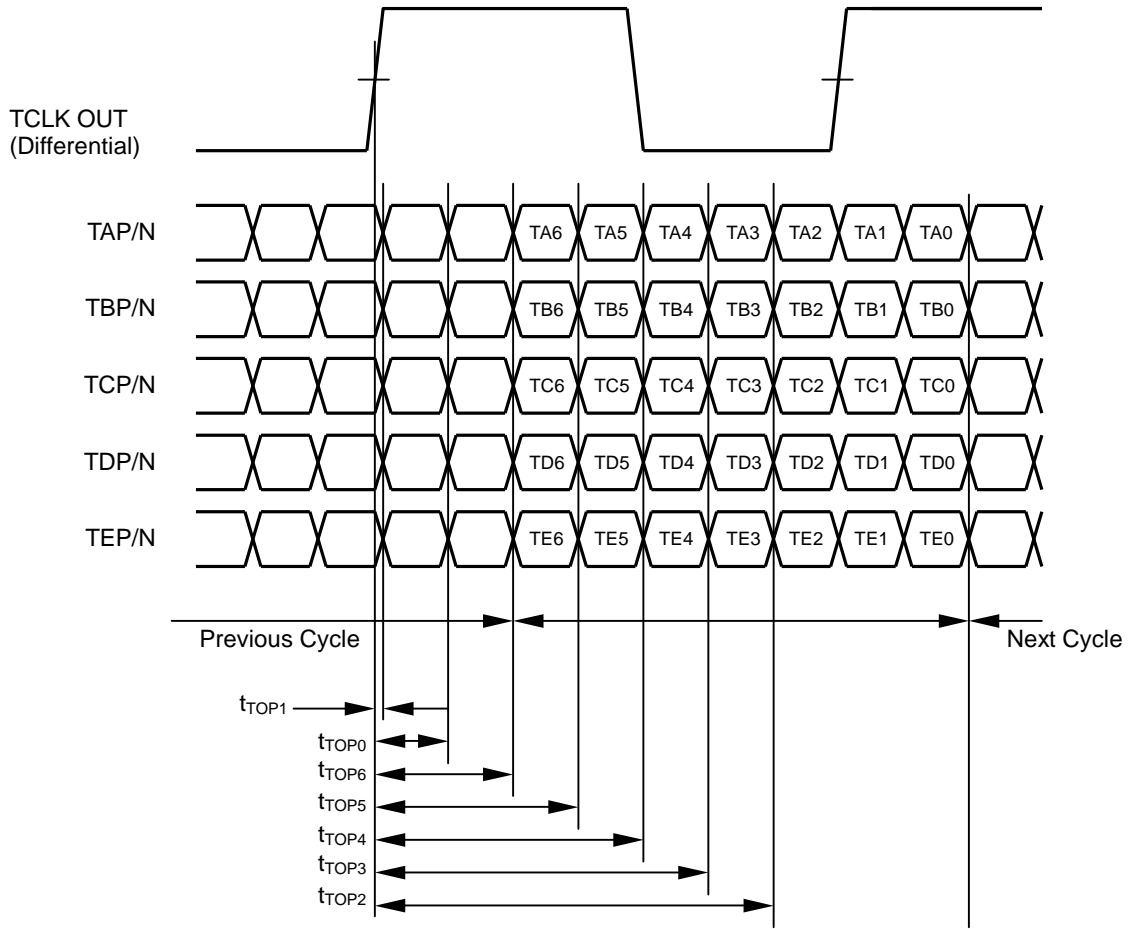

Fig.8 AC Timing Diagrams

■ Phase Locked Loop Set Time

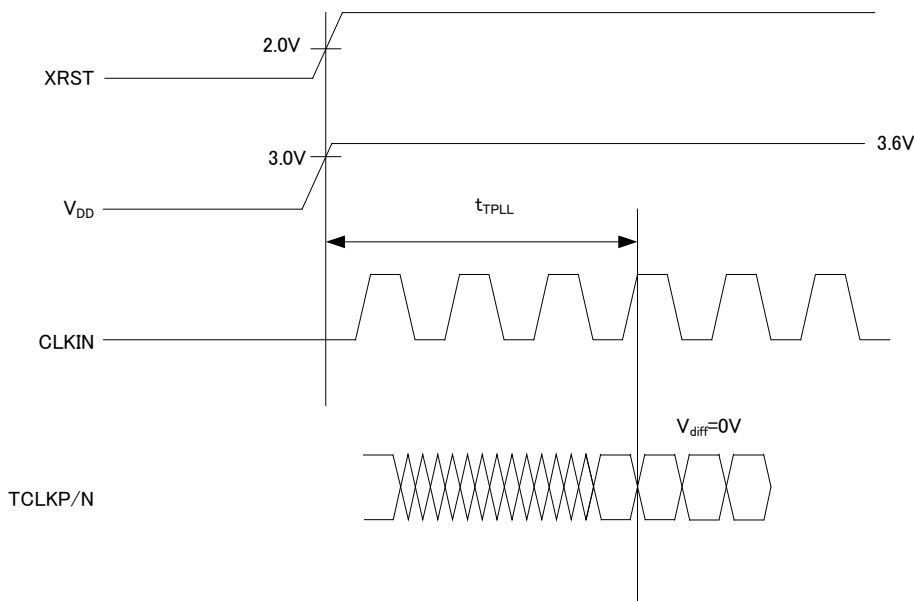

Fig.9 Phase Locked Loop Set Time

● System Timing Requirement

System Timing Requirement is mandatory by following two methods.

- ① The method of using CR circuit. (In the case that CLK does not stop after power supply)
- ② The method of using external specific IC. (In the case that CLK turns on/off after power supply)

It is recommend to do enough examination for target application.

- ① The method of using CR circuit. (In the case that CLK does not stop after power supply)

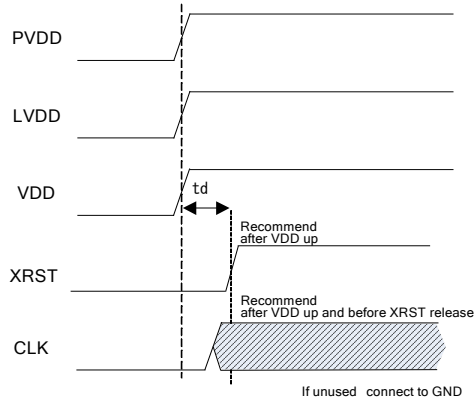
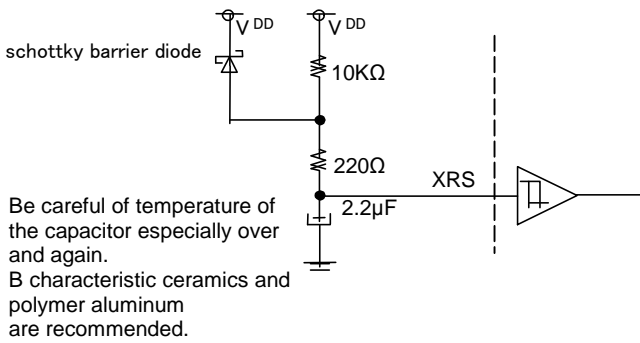

td is approximately equal to 20ms when the left RC coeuls are applied.

Fig.10 The method of using CR circuit.

- ② The method of using external specific IC. (In the case that CLK turns on/off after power supply)

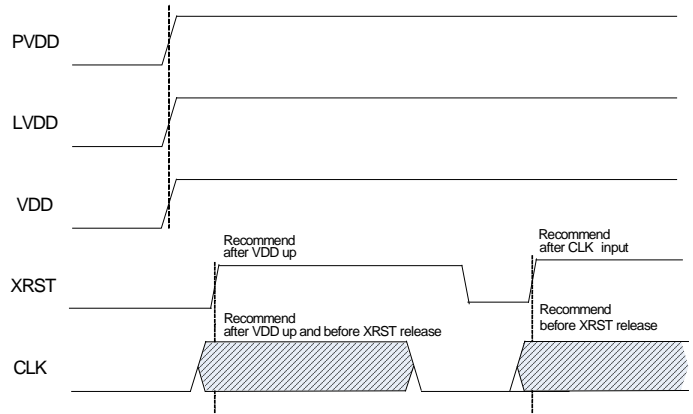
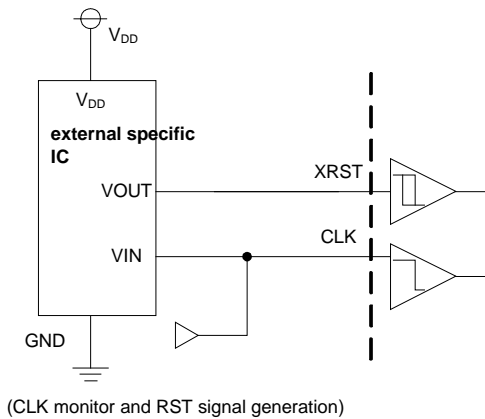
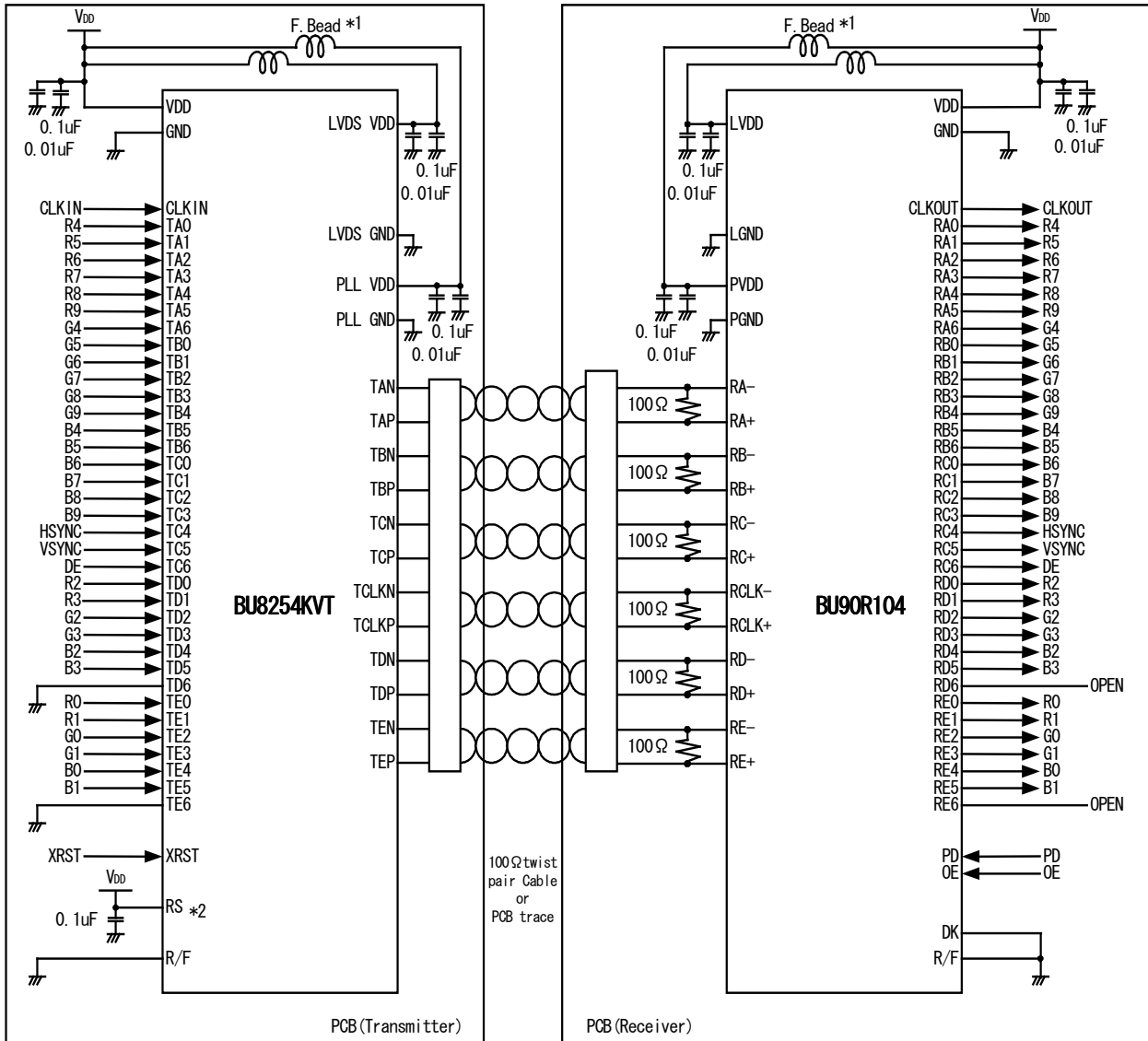

Fig.11 The method of using external specific IC.

●10bit LVCMOS Level Input

Example:
 BU8254KVT: LVCMOS level input/Falling edge/Normal swing
 BU90R104: Falling edge



*1: Recommended Parts:
 F.Bead : BLM18A-Series (Murata Manufacturing)

*2 If RS pin is tied to VDD, LVDS swing is 350m V.
 If RS pin is tied to GND, LVDS swing is 200m V.

●10bit Small Swing Input

Example:
 BU8254KVT : LVCMOS level input/Falling edge/Normal swing
 BU90R104: Falling edge

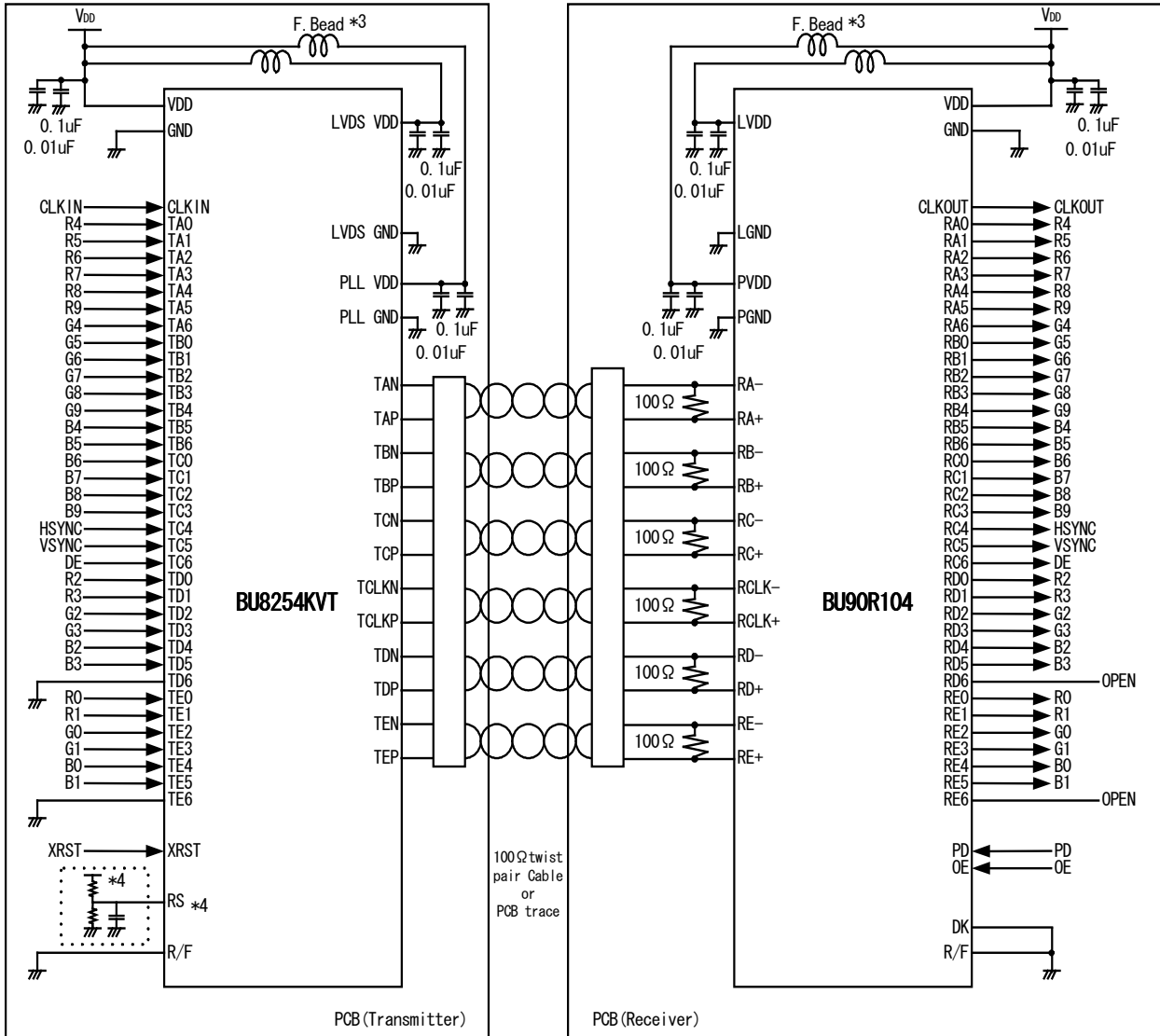

*3 : Recommended Parts:

F.Bead : BLM18A-Series (Murata Manufacturing)

*4 : RS pin acts as VREF input pin when input voltage is set to half of high level signal input.
 We recommend to locate by-pass condenser near the RS pin.

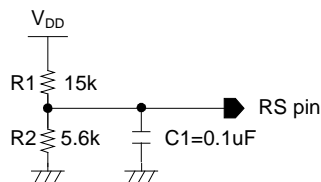

Example for LVCMOS(1.8V input)(R1,R2)=(1.5kΩ,5.6kΩ)

●Ordering Part Number

| | |
|---|---|
| B | U |
|---|---|

Part No.

| | | | |
|---|---|---|---|
| 8 | 2 | 5 | 4 |
|---|---|---|---|

Part No.

| | | |
|---|---|---|
| K | V | T |
|---|---|---|

Package
KVT: TQFP64V

| | |
|--|--|
| | |
|--|--|

Packaging and forming specification
None:Tray

TQFP64V

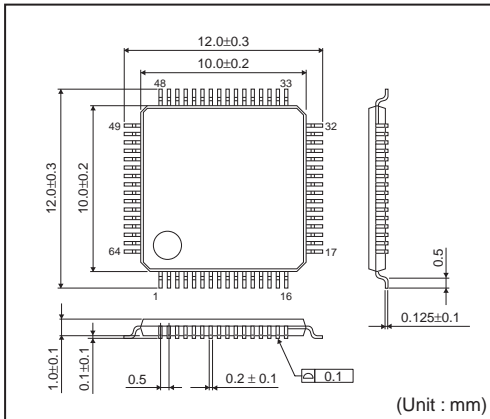

<Tape and Reel information>

| | |
|-------------------|---|
| Container | Tray (with dry pack) |
| Quantity | 1000pcs |
| Direction of feed | Direction of product is fixed in a tray |

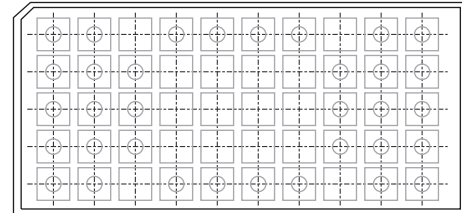
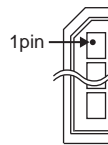

* Order quantity needs to be multiple of the minimum quantity.

Notice

Precaution on using ROHM Products

- Our Products are designed and manufactured for application in ordinary electronic equipments (such as AV equipment, OA equipment, telecommunication equipment, home electronic appliances, amusement equipment, etc.). If you intend to use our Products in devices requiring extremely high reliability (such as medical equipment ^(Note 1), transport equipment, traffic equipment, aircraft/spacecraft, nuclear power controllers, fuel controllers, car equipment including car accessories, safety devices, etc.) and whose malfunction or failure may cause loss of human life, bodily injury or serious damage to property ("Specific Applications"), please consult with the ROHM sales representative in advance. Unless otherwise agreed in writing by ROHM in advance, ROHM shall not be in any way responsible or liable for any damages, expenses or losses incurred by you or third parties arising from the use of any ROHM's Products for Specific Applications.

(Note1) Medical Equipment Classification of the Specific Applications

| JAPAN | USA | EU | CHINA |
|-----------|-----------|------------|-----------|
| CLASS III | CLASS III | CLASS II b | CLASS III |
| CLASS IV | | CLASS III | |

- ROHM designs and manufactures its Products subject to strict quality control system. However, semiconductor products can fail or malfunction at a certain rate. Please be sure to implement, at your own responsibilities, adequate safety measures including but not limited to fail-safe design against the physical injury, damage to any property, which a failure or malfunction of our Products may cause. The following are examples of safety measures:
 - Installation of protection circuits or other protective devices to improve system safety
 - Installation of redundant circuits to reduce the impact of single or multiple circuit failure
- Our Products are designed and manufactured for use under standard conditions and not under any special or extraordinary environments or conditions, as exemplified below. Accordingly, ROHM shall not be in any way responsible or liable for any damages, expenses or losses arising from the use of any ROHM's Products under any special or extraordinary environments or conditions. If you intend to use our Products under any special or extraordinary environments or conditions (as exemplified below), your independent verification and confirmation of product performance, reliability, etc. prior to use, must be necessary:
 - Use of our Products in any types of liquid, including water, oils, chemicals, and organic solvents
 - Use of our Products outdoors or in places where the Products are exposed to direct sunlight or dust
 - Use of our Products in places where the Products are exposed to sea wind or corrosive gases, including Cl₂, H₂S, NH₃, SO₂, and NO₂
 - Use of our Products in places where the Products are exposed to static electricity or electromagnetic waves
 - Use of our Products in proximity to heat-producing components, plastic cords, or other flammable items
 - Sealing or coating our Products with resin or other coating materials
 - Use of our Products without cleaning residue of flux (even if you use no-clean type fluxes, cleaning residue of flux is recommended); or Washing our Products by using water or water-soluble cleaning agents for cleaning residue after soldering
 - Use of the Products in places subject to dew condensation
- The Products are not subject to radiation-proof design.
- Please verify and confirm characteristics of the final or mounted products in using the Products.
- In particular, if a transient load (a large amount of load applied in a short period of time, such as pulse. is applied, confirmation of performance characteristics after on-board mounting is strongly recommended. Avoid applying power exceeding normal rated power; exceeding the power rating under steady-state loading condition may negatively affect product performance and reliability.
- De-rate Power Dissipation (Pd) depending on Ambient temperature (Ta). When used in sealed area, confirm the actual ambient temperature.
- Confirm that operation temperature is within the specified range described in the product specification.
- ROHM shall not be in any way responsible or liable for failure induced under deviant condition from what is defined in this document.

Precaution for Mounting / Circuit board design

- When a highly active halogenous (chlorine, bromine, etc.) flux is used, the residue of flux may negatively affect product performance and reliability.
- In principle, the reflow soldering method must be used; if flow soldering method is preferred, please consult with the ROHM representative in advance.

For details, please refer to ROHM Mounting specification

Precautions Regarding Application Examples and External Circuits

1. If change is made to the constant of an external circuit, please allow a sufficient margin considering variations of the characteristics of the Products and external components, including transient characteristics, as well as static characteristics.
2. You agree that application notes, reference designs, and associated data and information contained in this document are presented only as guidance for Products use. Therefore, in case you use such information, you are solely responsible for it and you must exercise your own independent verification and judgment in the use of such information contained in this document. ROHM shall not be in any way responsible or liable for any damages, expenses or losses incurred by you or third parties arising from the use of such information.

Precaution for Electrostatic

This Product is electrostatic sensitive product, which may be damaged due to electrostatic discharge. Please take proper caution in your manufacturing process and storage so that voltage exceeding the Products maximum rating will not be applied to Products. Please take special care under dry condition (e.g. Grounding of human body / equipment / solder iron, isolation from charged objects, setting of ionizer, friction prevention and temperature / humidity control).

Precaution for Storage / Transportation

1. Product performance and soldered connections may deteriorate if the Products are stored in the places where:
 - [a] the Products are exposed to sea winds or corrosive gases, including Cl₂, H₂S, NH₃, SO₂, and NO₂
 - [b] the temperature or humidity exceeds those recommended by ROHM
 - [c] the Products are exposed to direct sunshine or condensation
 - [d] the Products are exposed to high Electrostatic
2. Even under ROHM recommended storage condition, solderability of products out of recommended storage time period may be degraded. It is strongly recommended to confirm solderability before using Products of which storage time is exceeding the recommended storage time period.
3. Store / transport cartons in the correct direction, which is indicated on a carton with a symbol. Otherwise bent leads may occur due to excessive stress applied when dropping of a carton.
4. Use Products within the specified time after opening a humidity barrier bag. Baking is required before using Products of which storage time is exceeding the recommended storage time period.

Precaution for Product Label

QR code printed on ROHM Products label is for ROHM's internal use only.

Precaution for Disposition

When disposing Products please dispose them properly using an authorized industry waste company.

Precaution for Foreign Exchange and Foreign Trade act

Since our Products might fall under controlled goods prescribed by the applicable foreign exchange and foreign trade act, please consult with ROHM representative in case of export.

Precaution Regarding Intellectual Property Rights

1. All information and data including but not limited to application example contained in this document is for reference only. ROHM does not warrant that foregoing information or data will not infringe any intellectual property rights or any other rights of any third party regarding such information or data. ROHM shall not be in any way responsible or liable for infringement of any intellectual property rights or other damages arising from use of such information or data.:
2. No license, expressly or implied, is granted hereby under any intellectual property rights or other rights of ROHM or any third parties with respect to the information contained in this document.

Other Precaution



1. This document may not be reprinted or reproduced, in whole or in part, without prior written consent of ROHM.
2. The Products may not be disassembled, converted, modified, reproduced or otherwise changed without prior written consent of ROHM.
3. In no event shall you use in any way whatsoever the Products and the related technical information contained in the Products or this document for any military purposes, including but not limited to, the development of mass-destruction weapons.
4. The proper names of companies or products described in this document are trademarks or registered trademarks of ROHM, its affiliated companies or third parties.

General Precaution

1. Before you use our Products, you are requested to carefully read this document and fully understand its contents. ROHM shall not be in any way responsible or liable for failure, malfunction or accident arising from the use of any ROHM's Products against warning, caution or note contained in this document.
2. All information contained in this document is current as of the issuing date and subject to change without any prior notice. Before purchasing or using ROHM's Products, please confirm the latest information with a ROHM sales representative.
3. The information contained in this document is provided on an "as is" basis and ROHM does not warrant that all information contained in this document is accurate and/or error-free. ROHM shall not be in any way responsible or liable for any damages, expenses or losses incurred by you or third parties resulting from inaccuracy or errors of or concerning such information.

Looking for pricing, stock, or lifecycle information?

Click below to explore more details on WIN SOURCE:

-  [View BU8254KVT-E2 on WIN SOURCE](#)
-  [Rohm Semiconductor](#) Information

Optimize Your Supply Chain with WIN SOURCE Solutions

-  Global Sourcing Solution
-  Obsolete Management
-  Cost Control Management
-  Shortage Management
-  Alternative Solution
-  Excess Inventory Management