

LVDS Interface ICs

# 56bit LVDS Receiver 8:56 Deserializer



BU7985KVT

No.12057EAT04

**●Description**

LVDS Interface IC of ROHM "Serializer" "Deserializer" operate from 8MHz to 150MHz wide clock range, and number of bits range is from 35 to 70. Data is transmitted seven times (7X) stream and reduce cable number by 3(1/3) or less. The ROHM's LVDS has low swing mode to be able to expect further low EMI.

**●Features**

- 1) Wide dot clock range: Single (112MHz)/Dual (180MHz) (NTSC, VGA, SVGA, WXGA UXGA)
- 2) Support clock frequency from 20MHz up to 112MHz.
- 3) User programmable LVCMOS data output triggering timing by using either rising or falling edge of clock.
- 4) User programmable LVCMOS data and clock output driving ability.
- 5) Support Fail-Safe Hi-z Operation.
- 6) 56bit LVDS transmitter is recommended to use BU7988KVT.

**●Applications**

Flat Panel Display

**●Precaution**

- This chip is not designed to protect from radioactivity.

●Block Diagram

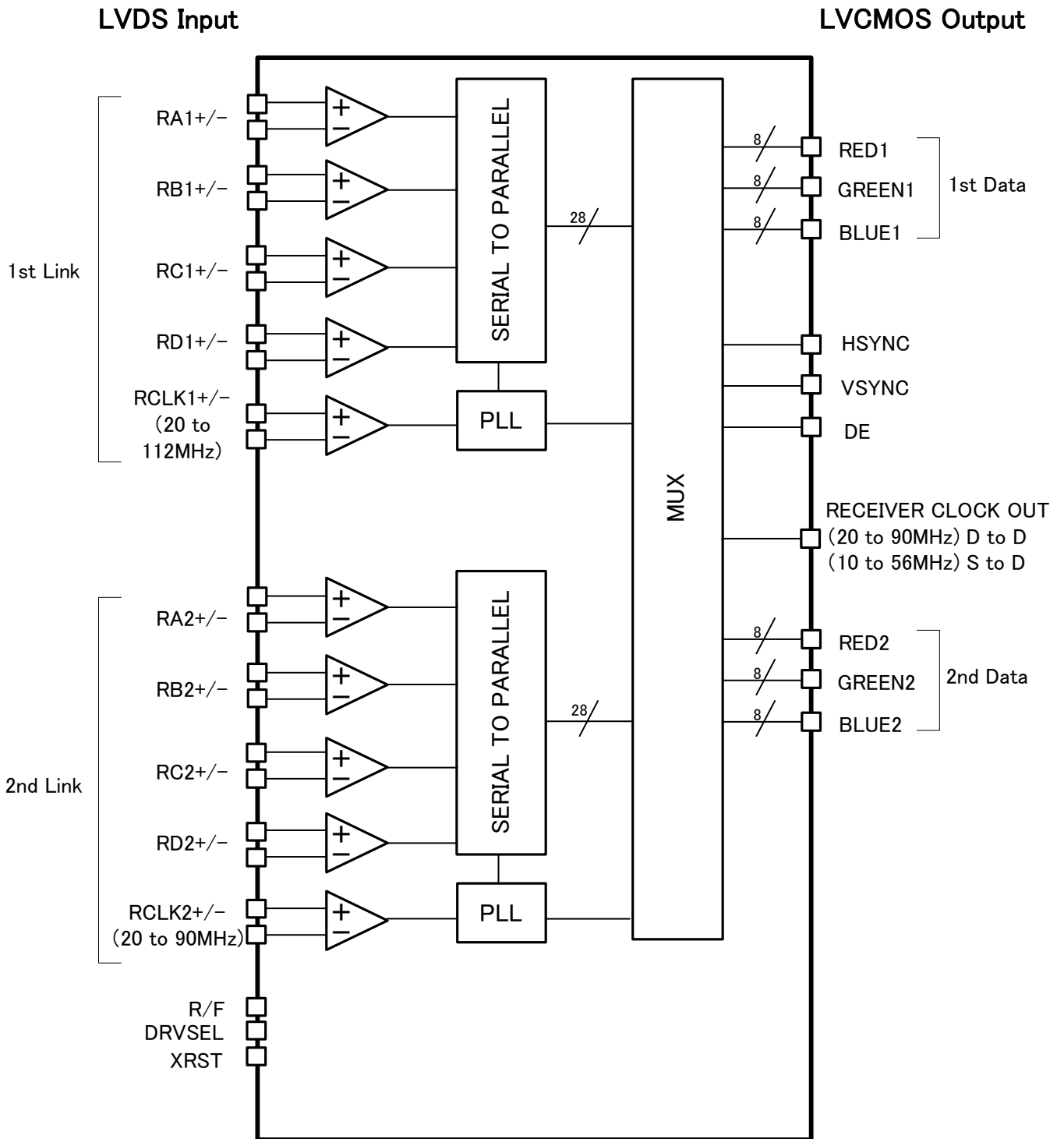

Fig.1 Block Diagram

●TQFP100V Package Outline and Specification

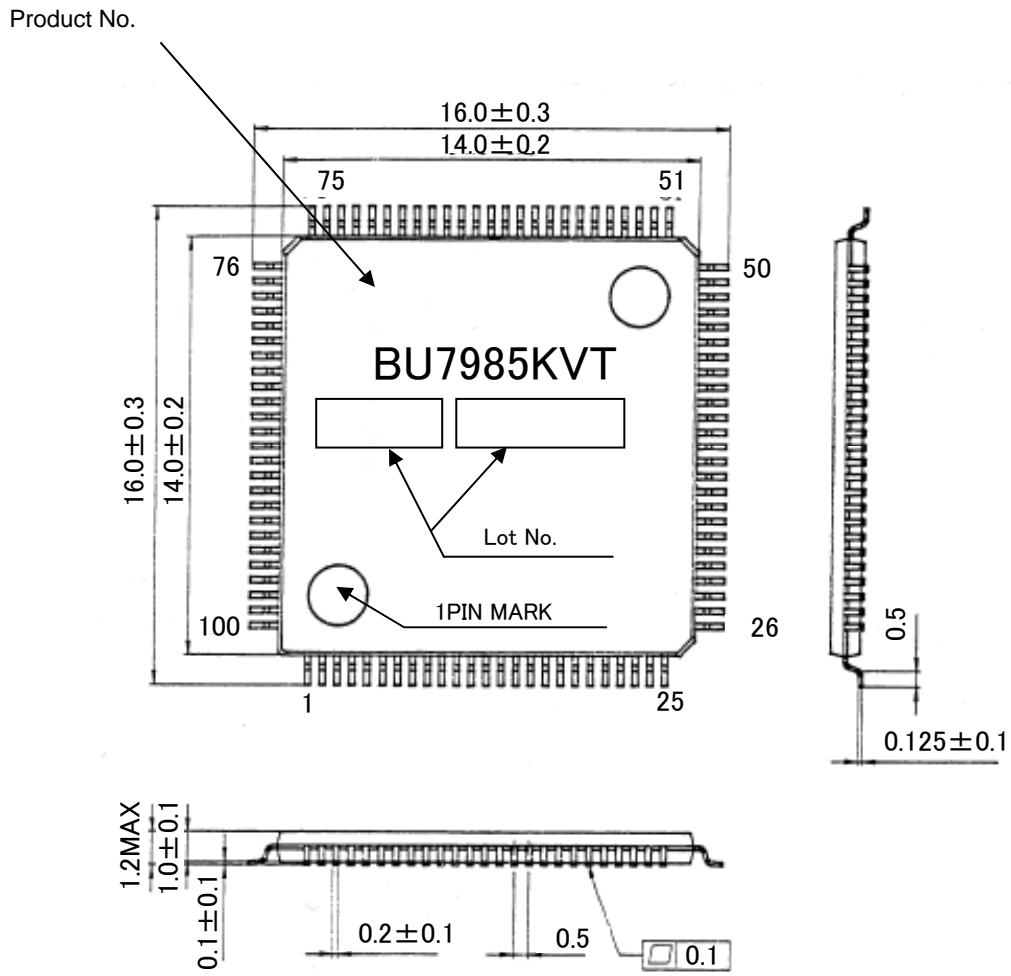

Fig.2 TQFP100V Package Outline and Specification



## ● Pin Description

Table 1 : Pin Description

Pin Name	Pin No.	Type	Descriptions															
RA1+, RA1-	78, 77	LVDS IN	LVDS Data Input for 1st Link. The 1st pixel input data when Dual Link. + : Positive input of LVDS data differential pair. - : Negative input of LVDS data differential pair.															
RB1+, RB1-	80, 79	LVDS IN																
RC1+, RC1-	83, 82	LVDS IN																
RD1+, RD1-	87, 86	LVDS IN																
RCLK1+, RCLK1-	85, 84	LVDS IN	LVDS Clock Input for 1st Link.															
RA2+, RA2-	90, 89	LVDS IN	LVDS Data Input for 2nd Link. These pins are disabled when Single Link. + : Positive input of LVDS data differential pair. - : Negative input of LVDS data differential pair.															
RB2+, RB2-	92, 91	LVDS IN																
RC2+, RC2-	95, 94	LVDS IN																
RD2+, RD2-	99, 98	LVDS IN																
RCLK2+, RCLK2-	97, 96	LVDS IN	LVDS Clock Input for 2nd Link.															
R17 ~ R10	52, 51, 50, 47, 46, 45, 44, 43	OUT	The 1st Pixel Data Outputs.															
G17 ~ G10	62, 61, 60, 59, 58, 55, 54, 53	OUT																
B17 ~ B10	72, 71, 68, 67, 66, 65, 64, 63	OUT																
R27 ~ R20	19, 18, 17, 14, 13, 12, 11, 10	OUT	The 2nd Pixel Data Outputs.															
G27 ~ G20	29, 26, 25, 24, 23, 22, 21, 20	OUT																
B27 ~ B20	39, 38, 37, 36, 35, 32, 31, 30	OUT																
DE	75	OUT	Data Enable Output.															
VSYNC	74	OUT	Vsync Output.															
HSYNC	73	OUT	Hsync Output.															
CLKOUT	40	OUT	Clock Output.															
DRVSEL	9	IN	Output Driverbility Select. L: Data output 2mA / Clock output 4mA H: Data output 4mA / Clock output 8mA															
R/F	8	IN	Output Clock Triggering Edge Select. H: Rising edge, L: Falling edge.															
MODE1,MODE0	6, 5	IN	Pixel Data Mode. <table border="1"> <thead> <tr> <th>MODE1</th> <th>MODE0</th> <th>Mode</th> </tr> </thead> <tbody> <tr> <td>L</td> <td>L</td> <td>Dual Link</td> </tr> <tr> <td>L</td> <td>H</td> <td>Single Link</td> </tr> <tr> <td>H</td> <td>L</td> <td>Dual Link With Fail-Safe Hiz</td> </tr> <tr> <td>H</td> <td>H</td> <td>Single Link With Fail-Safe Hiz</td> </tr> </tbody> </table>	MODE1	MODE0	Mode	L	L	Dual Link	L	H	Single Link	H	L	Dual Link With Fail-Safe Hiz	H	H	Single Link With Fail-Safe Hiz
MODE1	MODE0	Mode																
L	L	Dual Link																
L	H	Single Link																
H	L	Dual Link With Fail-Safe Hiz																
H	H	Single Link With Fail-Safe Hiz																

Pin Name	Pin No.	Type	Descriptions
XRST	4	IN	H: Normal operation, L: Power down (all outputs are pulled to ground)
VDD	15, 27, 33, 41, 48, 56, 69	Power	Power Supply Pins for LVCMOS outputs and digital circuitry.
GND	3, 7, 16, 28, 34, 42, 49, 57, 70	Ground	Ground Pins for LVCMOS outputs and digital circuitry.
LVDS VDD	81,93	Power	Power Supply Pins for LVDS inputs.
LVDS GND	76, 88, 100	Ground	Ground Pins for LVDS inputs.
PLL VDD	2	Power	Power Supply Pin for PLL circuitry.
PLL GND	1	Ground	Ground Pin for PLL circuitry.

## ●Electrical characteristics

### ■Rating

Table 2 : Absolute maximum rating

Item	Symbol	Value		Unit
		Min.	Max.	
Supply voltage	VDD	-0.3	4.0	V
Input voltage	VIN	-0.3	VDD+0.3	V
Output voltage	VOOUT	-0.3	VDD+0.3	V
Storage temperature range	Tstg	-55	125	°C

Table 3 : Package Power

PACKAGE	Power Dissipation (mW)	De-rating (mW/°C) <sup>*1</sup>
TQFP100V	900	9.0
	1400 <sup>*2</sup>	14.0 <sup>*2</sup>
	2550 <sup>*2</sup>	25.5 <sup>*2</sup>

\*1: At temperature Ta >25°C

\*2: Package power when mounting on the PCB board.

The size of PCB board : 70 × 70 × 1.6 (mm<sup>3</sup>) / 140 × 150 × 1.6 (mm<sup>3</sup>)

The material of PCB board : The FR4 glass epoxy board.(3% or less copper foil area)

(It is recommended to apply the above package power requirement to PCB board when the small swing input mode is used)

Table 4 : Recommended Operating Conditions

Parameter	Symbol	Rating			Units	Conditions
		Min	Typ	Max		
ply Voltage	V <sub>DD</sub>	3.0	3.3	3.6	V	VDD,LVDSVDD,PLLVD
Operating Temperature Range	Topr	-20	-	85	°C	

## ■ DC characteristics

Table 5 : LVCMOS DC Specifications (VDD=3.0V~3.6V, Ta=-20°C~+85°C)

Parameter	Symbol	Rating			Units	Conditions
		Min	Typ	Max		
High Level Input Voltage	V <sub>IH</sub>	V <sub>DD</sub> × 0.8	-	V <sub>DD</sub>	V	
Low Level Input Voltage	V <sub>IL</sub>	GND	-	V <sub>DD</sub> × 0.2	V	
High Level Output Voltage	V <sub>OH</sub>	2.4	-	V <sub>DD</sub>	V	I <sub>OH</sub> = -2mA, -4mA (data) I <sub>OH</sub> = -4mA, -8mA (clock)
Low Level Output Voltage	V <sub>OL</sub>	0.0	-	0.4	V	I <sub>OL</sub> = 2mA, 4mA (data) I <sub>OL</sub> = 4mA, 8mA (clock)
Input Leak Current	I <sub>INC</sub>	-10	-	+10	μA	0V ≤ V <sub>IN</sub> ≤ V <sub>DD</sub>
Output Leak Current	I <sub>OZ</sub>	-10	-	+10	μA	Output=Hiz, 0V ≤ V <sub>OUT</sub> ≤ V <sub>DD</sub>

Table 6 : LVDS Receiver DC Specifications (VDD=3.0V~3.6V, Ta=-20°C~+85°C)

Parameter	Symbol	Rating			Units	Conditions
		Min	Typ	Max		
Differential Input High Threshold	V <sub>TH</sub>	-	-	100	mV	V <sub>OC</sub> =1.2V
Differential Input Low Threshold	V <sub>TL</sub>	-100	-	-	mV	V <sub>OC</sub> =1.2V
Input Current	I <sub>INL</sub>	-20	-	+20	μA	V <sub>IN</sub> =2.4V/0V V <sub>DD</sub> =3.6

■ Supply Current

Table 7 : Supply Current (VDD=3.3V, Ta=25°C)

Parameter	Symbol	Rating			Units	Conditions	
		Min	Typ	Max			
Receiver supply current (Gray scale pattern)	I <sub>RCCG</sub>	-	88	-	mA	MODE[1:0]=L L, H L CL=8pF	f=90MHz
		-	62	-	mA	MODE[1:0]=L H, H H CL=8pF	f=112MHz
Receiver supply current (Checker pattern)	I <sub>RCCW</sub>	-	137	-	mA	MODE[1:0]=L L, H L CL=8pF	f=90MHz
		-	89	-	mA	MODE[1:0]=L H, H H CL=8pF	f=112MHz
Receiver Power Down Supply Current	I <sub>RCCS</sub>	-	-	10	μA	XRST=L	

256 Gray Scale Pattern

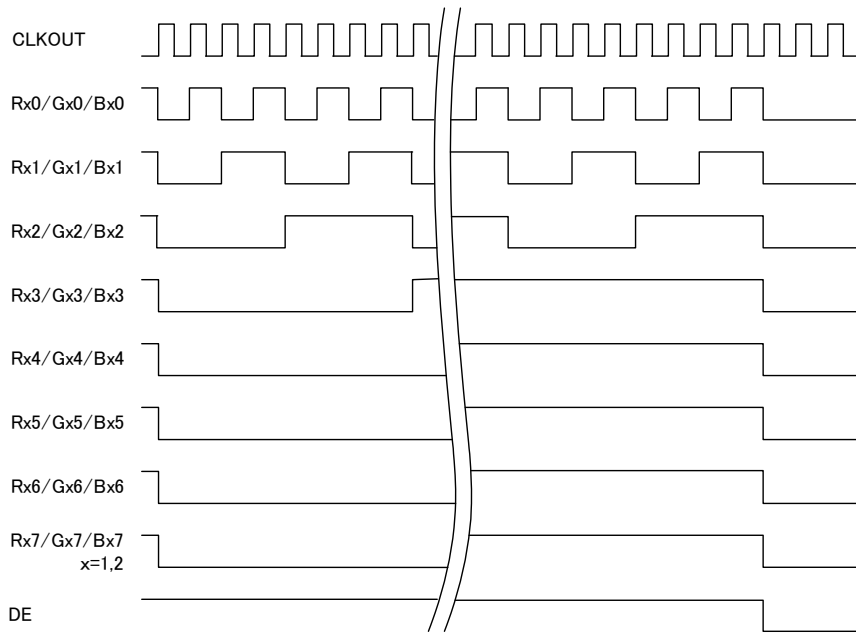

Fig.4 Gray scale pattern

Double Checker Pattern

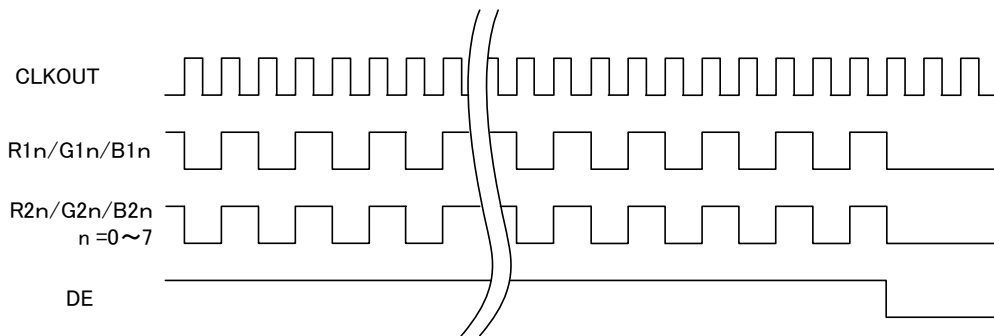

Fig.5 Checker pattern

## ■ AC characteristics

Table 8 : Switching Characteristics (VDD=3.0V~3.6V, Ta=-20°C~+85°C)

Parameter		Symbol	Min	Typ	Max	Units
CLK OUT Period	Dual-in / Dual-out	$t_{RCP}$	11.11	$t_{RCP}$	50	ns
	Single-in / Dual-out		17.85	$2t_{RCP}$	100	
CLKOUT High Time		$t_{RCH}$	-	$0.5t_{RCP}$	-	ns
CLKOUT Low Time		$t_{RCL}$	-	$0.5t_{RCP}$	-	ns
LVCMOS Data Setup to CLKOUT		$t_{RS}$	$0.3t_{RCP}$	-	-	ns
LVCMOS data hold from CLKOUT		$t_{RH}$	$0.3t_{RCP}$	-	-	ns
LVCMOS Low to High Transition Time		$t_{TLH}$	-	3.0	5.0	ns
LVCMOS Low to Low Transition Time		$t_{THL}$	-	3.0	5.0	
Input Data Position0 ( $T_{RCP} = 8.9ns$ )		$t_{RIP1}$	-0.25	0.0	+0.25	ns
Input Data Position1 ( $T_{RCP} = 8.9ns$ )		$t_{RIP0}$	$\frac{t_{RCP}}{7} - 0.25$	$\frac{t_{RCP}}{7}$	$2\frac{t_{RCP}}{7} + 0.25$	ns
Input Data Position2 ( $T_{RCP} = 8.9ns$ )		$t_{RIP6}$	$2\frac{t_{RCP}}{7} - 0.25$	$2\frac{t_{RCP}}{7}$	$2\frac{t_{RCP}}{7} + 0.25$	ns
Input Data Position3 ( $T_{RCP} = 8.9ns$ )		$t_{RIP5}$	$3\frac{t_{RCP}}{7} - 0.25$	$3\frac{t_{RCP}}{7}$	$3\frac{t_{RCP}}{7} + 0.25$	ns
Input Data Position4 ( $T_{RCP} = 8.9ns$ )		$t_{RIP4}$	$4\frac{t_{RCP}}{7} - 0.25$	$4\frac{t_{RCP}}{7}$	$4\frac{t_{RCP}}{7} + 0.25$	ns
Input Data Position5 ( $T_{RCP} = 8.9ns$ )		$t_{TOP3}$	$5\frac{t_{RCP}}{7} - 0.25$	$5\frac{t_{RCP}}{7}$	$5\frac{t_{RCP}}{7} + 0.25$	ns
Input Data Position6 ( $T_{RCP} = 8.9ns$ )		$t_{RIP2}$	$6\frac{t_{RCP}}{7} - 0.25$	$6\frac{t_{RCP}}{7}$	$6\frac{t_{RCP}}{7} + 0.25$	ns
Phase Lock Loop Set		$t_{RLL}$	-	-	10.0	ms
CLKIN Period		$t_{RCP}$	8.9	-	50	ns
Skew Time between RCLK1 and RCLK2		$t_{ck12}$	-	-	$\pm 0.3t_{RCP}$	ns

● AC Timing

■ LVC MOS

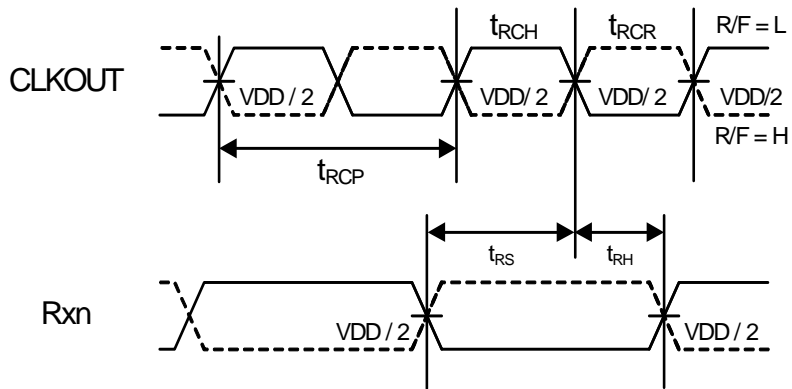
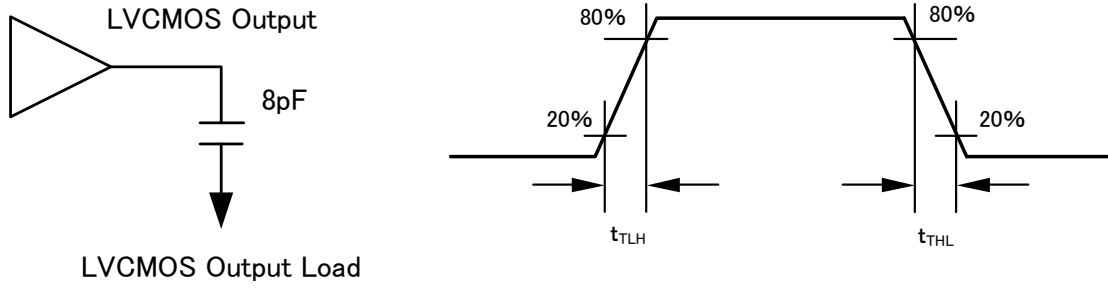

X=A,B,C,D  
n=0,1,2,3,4,5,6,

Fig.6 LVC MOS output timing

■ Phase-locked loops set time

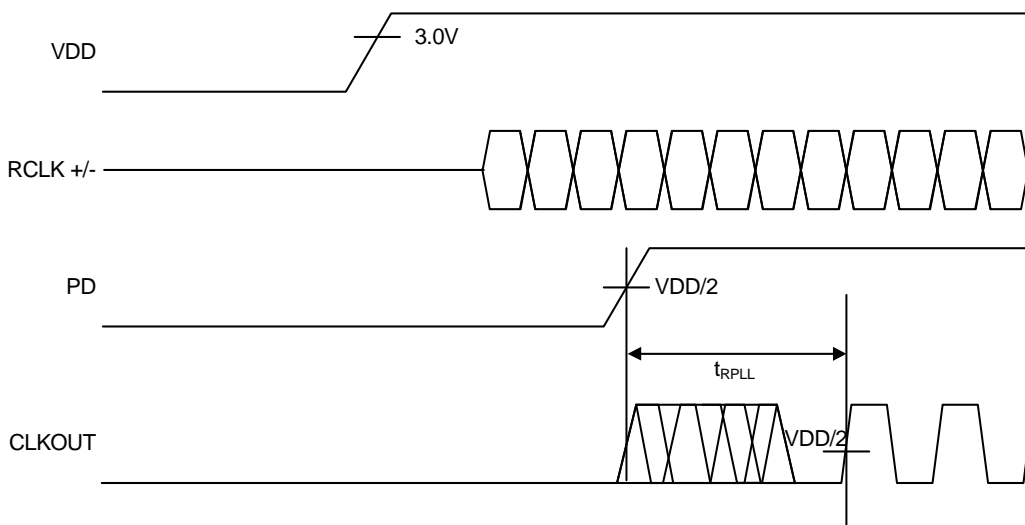

Fig.7 Phase-locked loops set time

■ AC Timing Diagrams

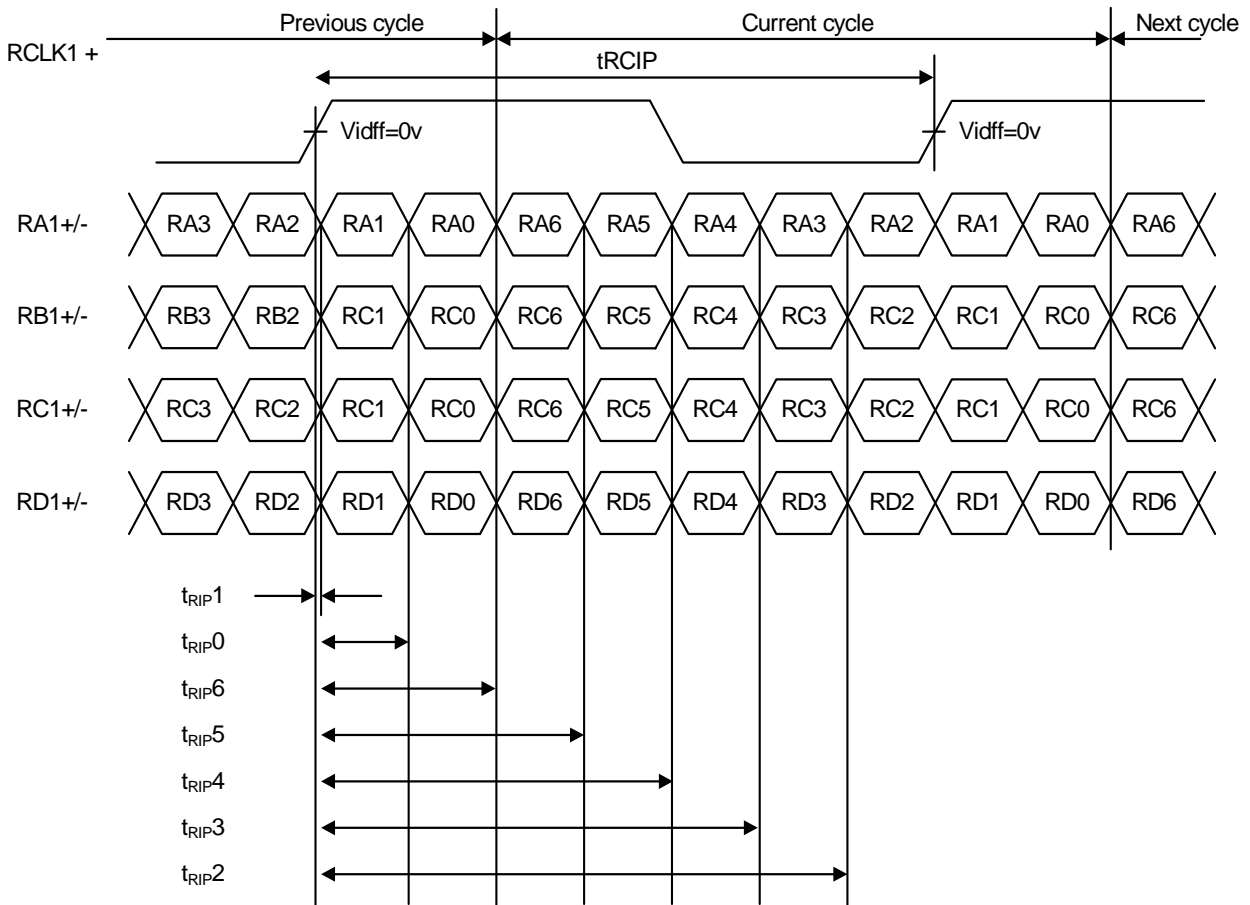

Fig.8 AC Timing Diagrams

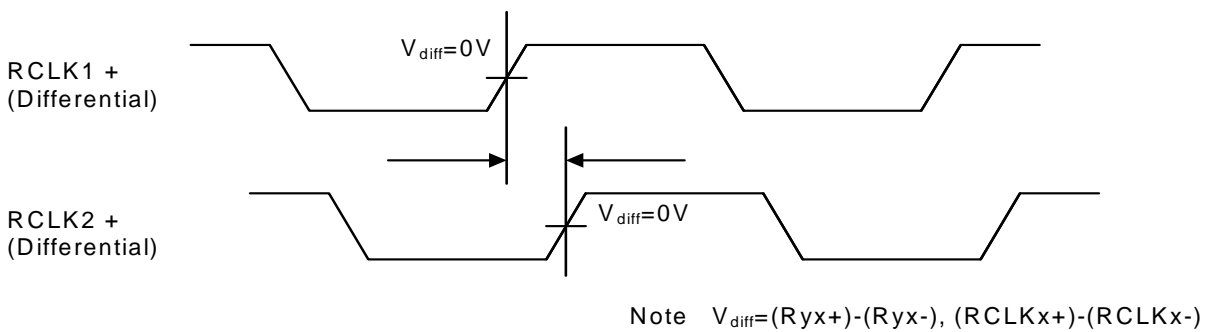

Fig.9 LVDS data and clock input timing

●LVDS Data, Clock Input and Output Timing

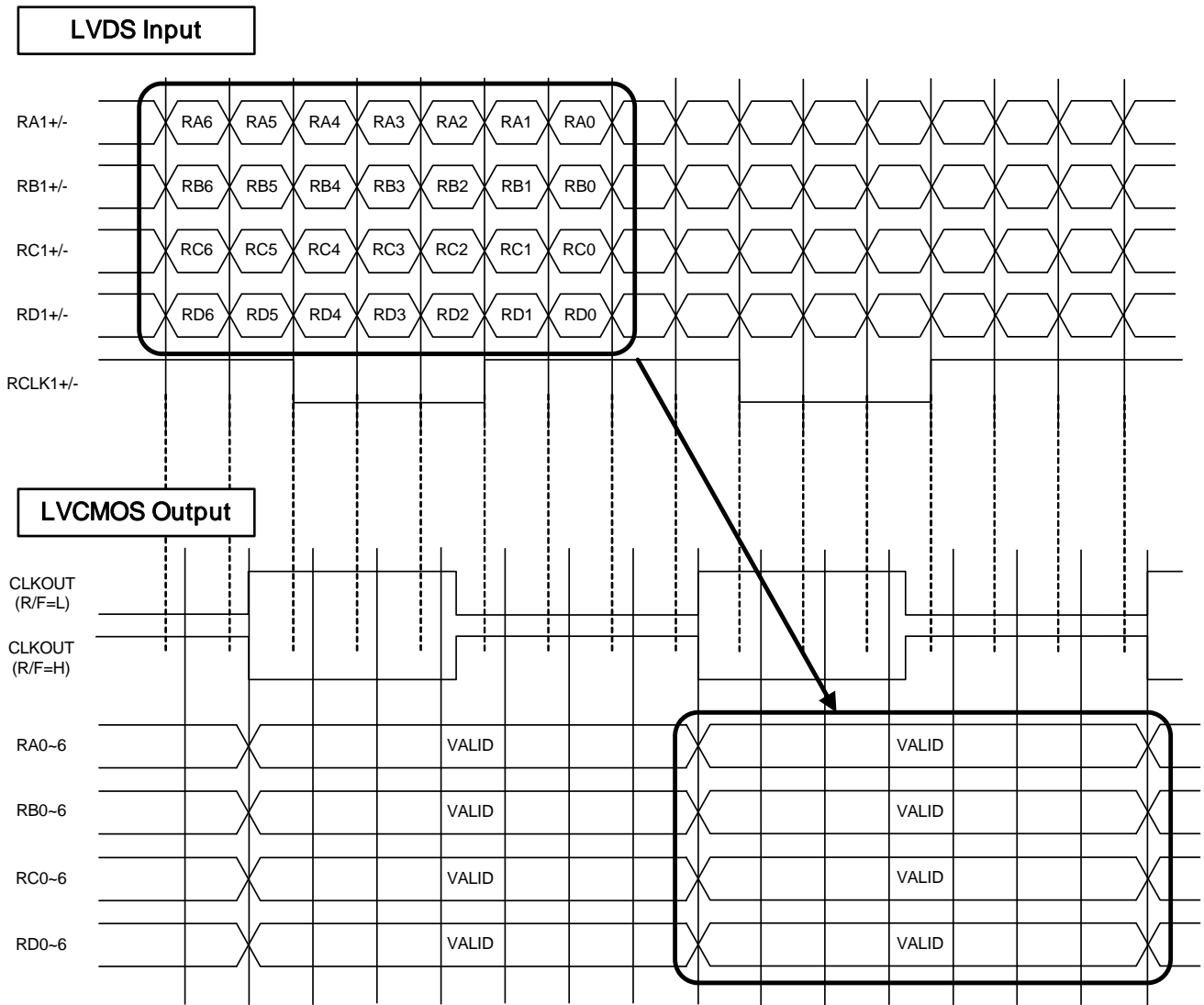

Fig.10 LVDS Data, Clock Input and Output Timing

●Pixel Map Table for Dual Link

Table 9: Pixel Map

1st Pixel Data				2nd Pixel Data			
TFT Panel Data			BU7985KVT LVCMOS Output Pin	TFT Panel Data			BU7985KVT LVCMOS Output Pin
	24Bit	18Bit			24Bit	18Bit	
LSB	R10	-	R10	LSB	R20	-	R20
	R11	-	R11		R21	-	R21
	R12	R10	R12		R22	R20	R22
	R13	R11	R13		R23	R21	R23
	R14	R12	R14		R24	R22	R24
	R15	R13	R15		R25	R23	R25
	R16	R14	R16		R26	R24	R26
MSB	R17	R15	R17	MSB	R27	R25	R27
LSB	G10	-	G10	LSB	G20	-	G20
	G11	-	G11		G21	-	G21
	G12	G10	G12		G22	G20	G22
	G13	G11	G13		G23	G21	G23
	G14	G12	G14		G24	G22	G24
	G15	G13	G15		G25	G23	G25
	G16	G14	G16		G26	G24	G26
MSB	G17	G15	G17	MSB	G27	G25	G27
LSB	B10	-	B10	LSB	B20	-	B20
	B11	-	B11		B21	-	B21
	B12	B10	B12		B22	B20	B22
	B13	B11	B13		B23	B21	B23
	B14	B12	B14		B24	B22	B24
	B15	B13	B15		B25	B23	B25
	B16	B14	B16		B26	B24	B26
MSB	B17	B15	B17	MSB	B27	B25	B27
	HSYNC	HSYNC	HSYNC		HSYNC	HSYNC	HSYNC
	VSYNC	VSYNC	VSYNC		VSYNC	VSYNC	VSYNC
	DE	DE	DE		DE	DE	DE

●CMOS Data Output Timing for Dual Link

Example : SXGA+(1400 × 1050)

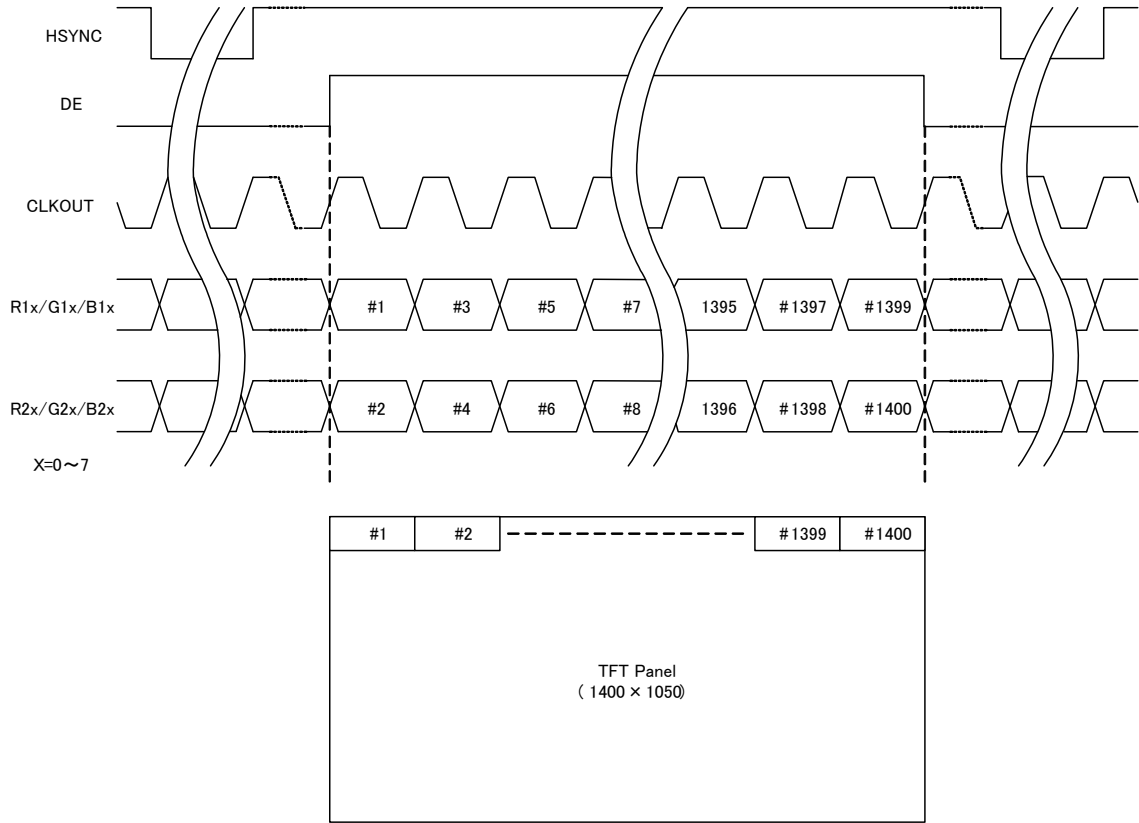

Fig.11 Data Output Timing for Dual Link

●CMOS Data Output Timing for Single Link

Example : SXGA+(1400 × 1050)

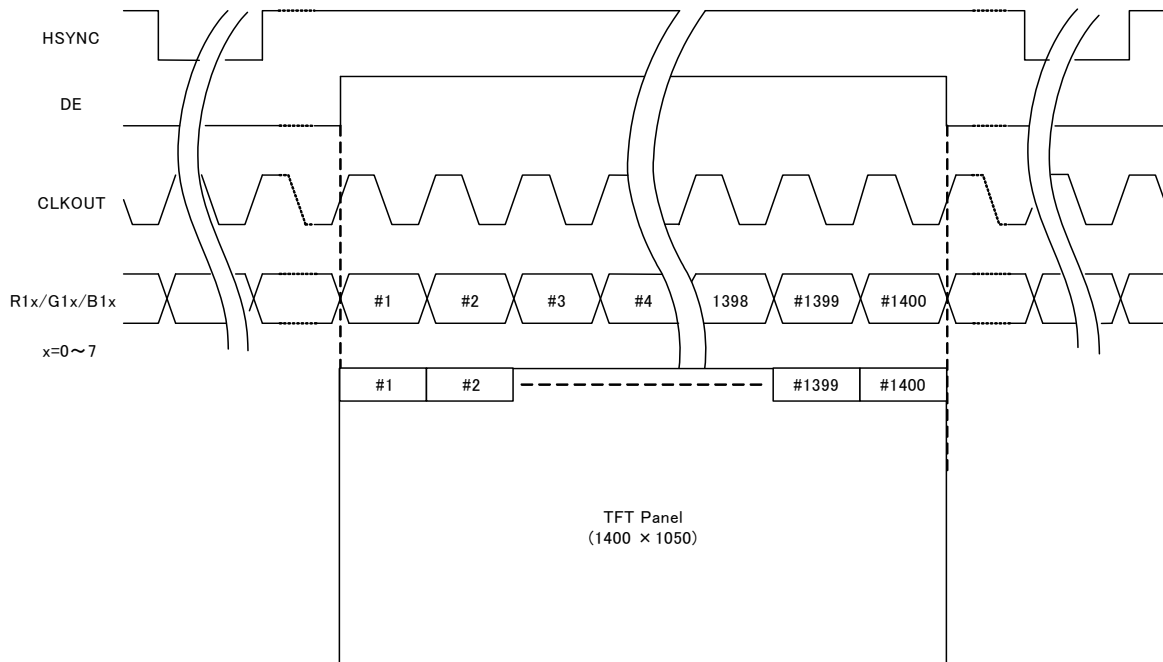

Fig.12 Data Output Timing for Dual Link

●LVDS Data Inputs Timing Diagrams in Dual Link  
(Dual-in / Dual-out Mode)

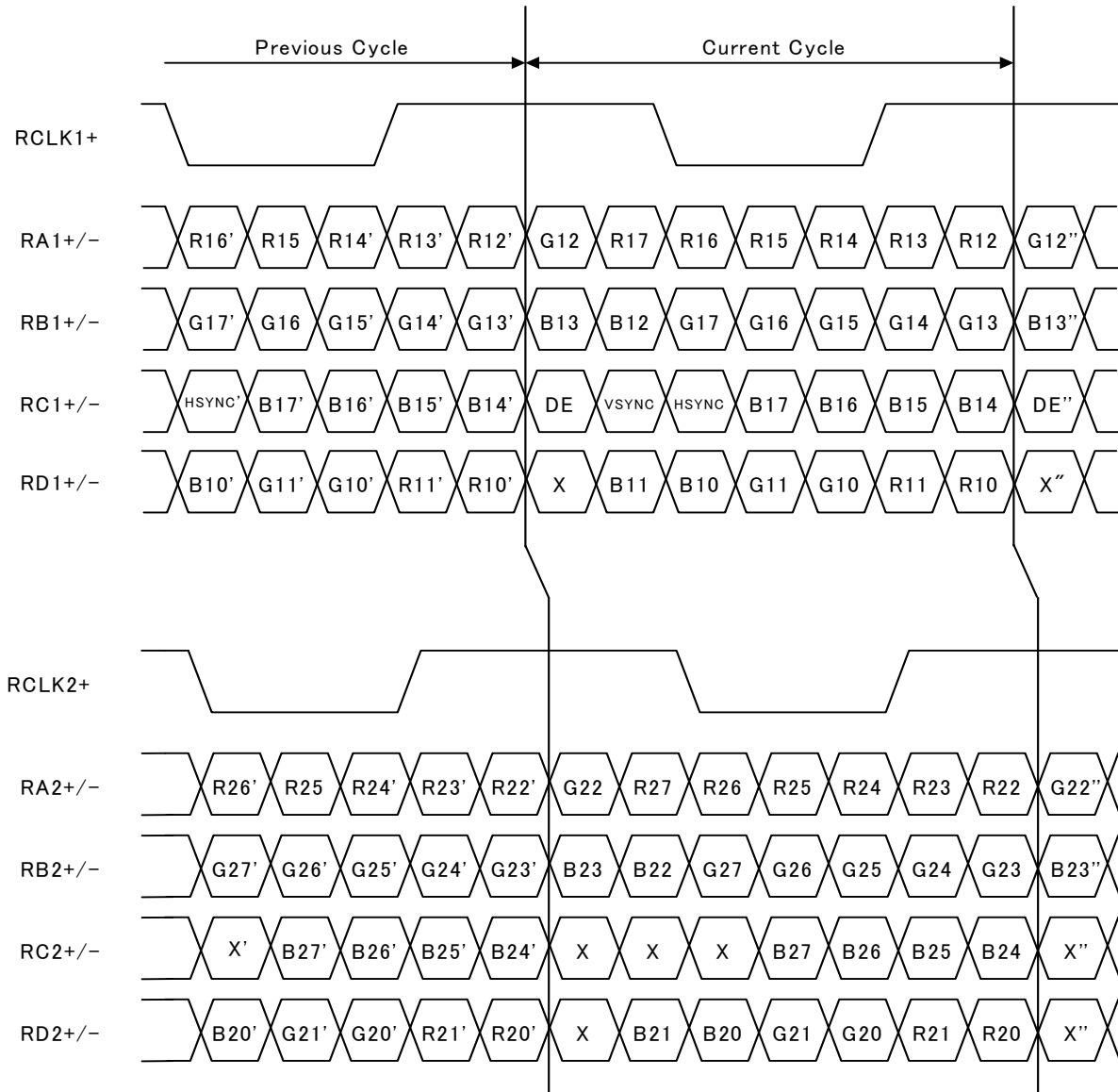

Fig.13 Data Input Timing for Dual Link

●LVDS Data Inputs Timing Diagrams in Single Link  
(Single-in / Dual-out Mode)

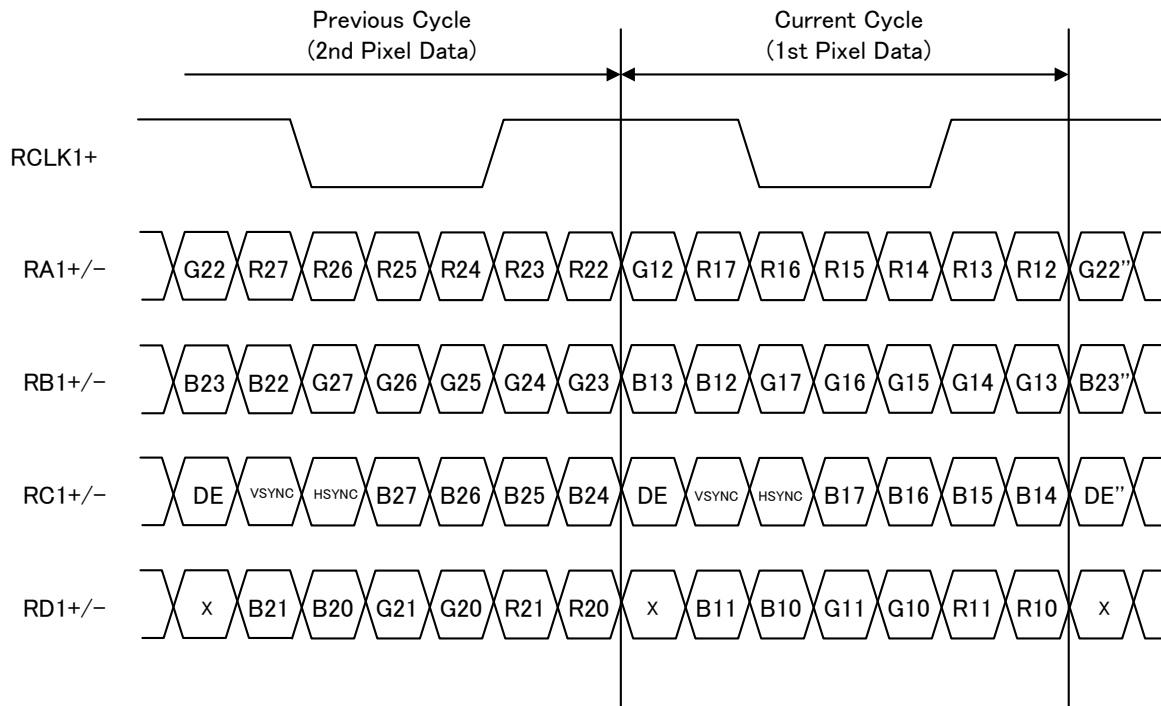

Fig.14 Data Input Timing for Single Link

●Fail-Safe Hi-Z Operation

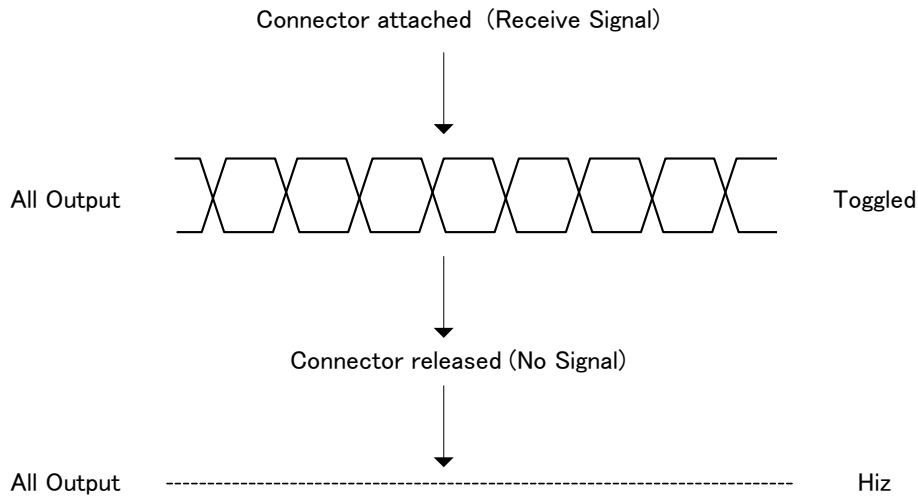

Fig.15 Fail-Sage Hi-Z Operation

●About the Power On Reset

Power On Reset is not mandatory for this device.  
 (The PD pin should be set to high level when Power On Reset procedure is not used.)

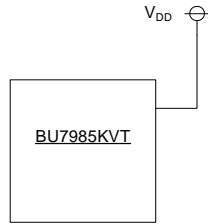

Fig.16 Terminal connection when Power On Reset is not used

However, Power On Reset procedure is strongly recommend for internal logic initialization by following two methods.

- ① The method of using CR circuit.
- ② The method of using external specific IC.

It is recommend to do enough examination for target application.

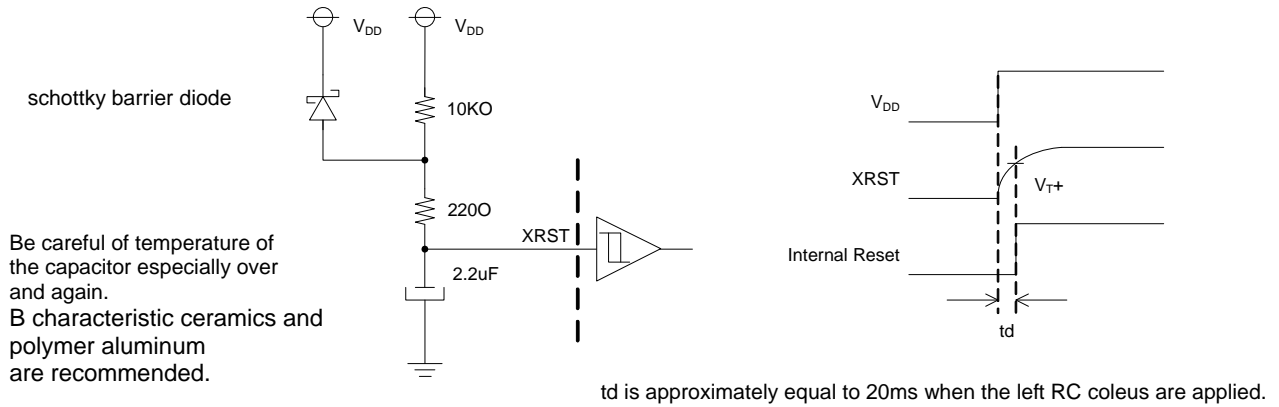

Fig.17 Power On Reset by external a CR circuit

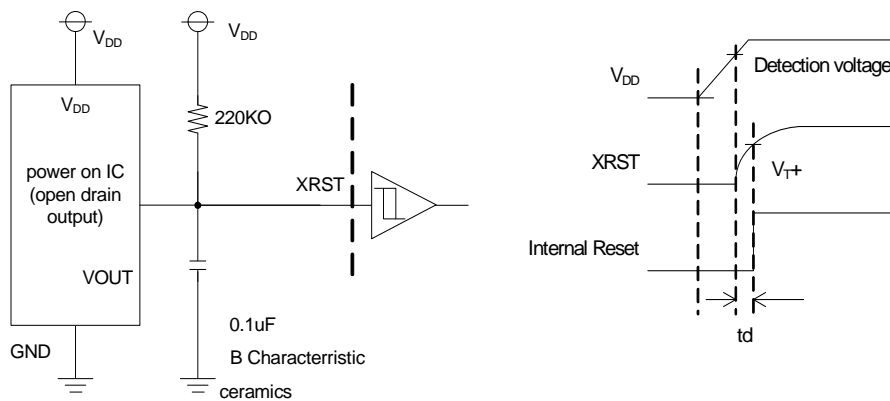

Fig.18 Power On Reset by specific IC

●Ordering Part Number

B	U
---	---

Part No.

7	9	8	5
---	---	---	---

Part No.

K	V	T
---	---	---

Package  
KVT: TQFP100V

--	--

Packaging and forming specification  
None:Tray

TQFP100V

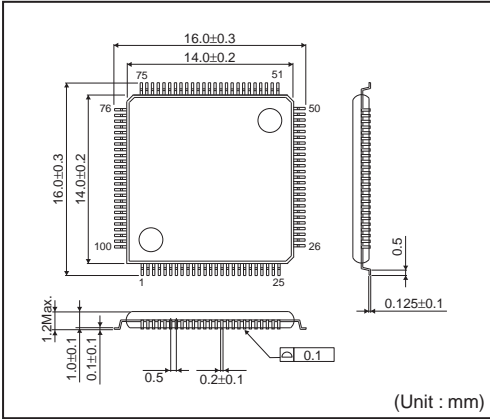

<Tape and Reel information>

Container	Tray (with dry pack)
Quantity	500pcs
Direction of feed	Direction of product is fixed in a tray

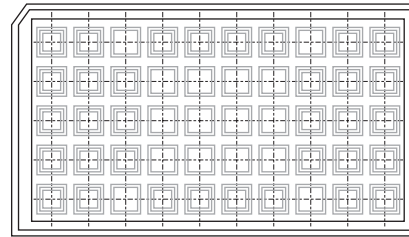
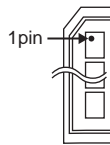

\*Order quantity needs to be multiple of the minimum quantity.

# Notice

## Precaution on using ROHM Products

- Our Products are designed and manufactured for application in ordinary electronic equipments (such as AV equipment, OA equipment, telecommunication equipment, home electronic appliances, amusement equipment, etc.). If you intend to use our Products in devices requiring extremely high reliability (such as medical equipment <sup>(Note 1)</sup>, transport equipment, traffic equipment, aircraft/spacecraft, nuclear power controllers, fuel controllers, car equipment including car accessories, safety devices, etc.) and whose malfunction or failure may cause loss of human life, bodily injury or serious damage to property ("Specific Applications"), please consult with the ROHM sales representative in advance. Unless otherwise agreed in writing by ROHM in advance, ROHM shall not be in any way responsible or liable for any damages, expenses or losses incurred by you or third parties arising from the use of any ROHM's Products for Specific Applications.

(Note1) Medical Equipment Classification of the Specific Applications

JAPAN	USA	EU	CHINA
CLASS III	CLASS III	CLASS II b	CLASS III
CLASS IV		CLASS III	

- ROHM designs and manufactures its Products subject to strict quality control system. However, semiconductor products can fail or malfunction at a certain rate. Please be sure to implement, at your own responsibilities, adequate safety measures including but not limited to fail-safe design against the physical injury, damage to any property, which a failure or malfunction of our Products may cause. The following are examples of safety measures:
  - Installation of protection circuits or other protective devices to improve system safety
  - Installation of redundant circuits to reduce the impact of single or multiple circuit failure
- Our Products are designed and manufactured for use under standard conditions and not under any special or extraordinary environments or conditions, as exemplified below. Accordingly, ROHM shall not be in any way responsible or liable for any damages, expenses or losses arising from the use of any ROHM's Products under any special or extraordinary environments or conditions. If you intend to use our Products under any special or extraordinary environments or conditions (as exemplified below), your independent verification and confirmation of product performance, reliability, etc. prior to use, must be necessary:
  - Use of our Products in any types of liquid, including water, oils, chemicals, and organic solvents
  - Use of our Products outdoors or in places where the Products are exposed to direct sunlight or dust
  - Use of our Products in places where the Products are exposed to sea wind or corrosive gases, including Cl<sub>2</sub>, H<sub>2</sub>S, NH<sub>3</sub>, SO<sub>2</sub>, and NO<sub>2</sub>
  - Use of our Products in places where the Products are exposed to static electricity or electromagnetic waves
  - Use of our Products in proximity to heat-producing components, plastic cords, or other flammable items
  - Sealing or coating our Products with resin or other coating materials
  - Use of our Products without cleaning residue of flux (even if you use no-clean type fluxes, cleaning residue of flux is recommended); or Washing our Products by using water or water-soluble cleaning agents for cleaning residue after soldering
  - Use of the Products in places subject to dew condensation
- The Products are not subject to radiation-proof design.
- Please verify and confirm characteristics of the final or mounted products in using the Products.
- In particular, if a transient load (a large amount of load applied in a short period of time, such as pulse. is applied, confirmation of performance characteristics after on-board mounting is strongly recommended. Avoid applying power exceeding normal rated power; exceeding the power rating under steady-state loading condition may negatively affect product performance and reliability.
- De-rate Power Dissipation (Pd) depending on Ambient temperature (Ta). When used in sealed area, confirm the actual ambient temperature.
- Confirm that operation temperature is within the specified range described in the product specification.
- ROHM shall not be in any way responsible or liable for failure induced under deviant condition from what is defined in this document.

## Precaution for Mounting / Circuit board design

- When a highly active halogenous (chlorine, bromine, etc.) flux is used, the residue of flux may negatively affect product performance and reliability.
- In principle, the reflow soldering method must be used; if flow soldering method is preferred, please consult with the ROHM representative in advance.

For details, please refer to ROHM Mounting specification

**Precautions Regarding Application Examples and External Circuits**

1. If change is made to the constant of an external circuit, please allow a sufficient margin considering variations of the characteristics of the Products and external components, including transient characteristics, as well as static characteristics.
2. You agree that application notes, reference designs, and associated data and information contained in this document are presented only as guidance for Products use. Therefore, in case you use such information, you are solely responsible for it and you must exercise your own independent verification and judgment in the use of such information contained in this document. ROHM shall not be in any way responsible or liable for any damages, expenses or losses incurred by you or third parties arising from the use of such information.

**Precaution for Electrostatic**

This Product is electrostatic sensitive product, which may be damaged due to electrostatic discharge. Please take proper caution in your manufacturing process and storage so that voltage exceeding the Products maximum rating will not be applied to Products. Please take special care under dry condition (e.g. Grounding of human body / equipment / solder iron, isolation from charged objects, setting of Ionizer, friction prevention and temperature / humidity control).

**Precaution for Storage / Transportation**

1. Product performance and soldered connections may deteriorate if the Products are stored in the places where:
  - [a] the Products are exposed to sea winds or corrosive gases, including Cl<sub>2</sub>, H<sub>2</sub>S, NH<sub>3</sub>, SO<sub>2</sub>, and NO<sub>2</sub>
  - [b] the temperature or humidity exceeds those recommended by ROHM
  - [c] the Products are exposed to direct sunshine or condensation
  - [d] the Products are exposed to high Electrostatic
2. Even under ROHM recommended storage condition, solderability of products out of recommended storage time period may be degraded. It is strongly recommended to confirm solderability before using Products of which storage time is exceeding the recommended storage time period.
3. Store / transport cartons in the correct direction, which is indicated on a carton with a symbol. Otherwise bent leads may occur due to excessive stress applied when dropping of a carton.
4. Use Products within the specified time after opening a humidity barrier bag. Baking is required before using Products of which storage time is exceeding the recommended storage time period.

**Precaution for Product Label**

QR code printed on ROHM Products label is for ROHM's internal use only.

**Precaution for Disposition**

When disposing Products please dispose them properly using an authorized industry waste company.

**Precaution for Foreign Exchange and Foreign Trade act**

Since our Products might fall under controlled goods prescribed by the applicable foreign exchange and foreign trade act, please consult with ROHM representative in case of export.

**Precaution Regarding Intellectual Property Rights**

1. All information and data including but not limited to application example contained in this document is for reference only. ROHM does not warrant that foregoing information or data will not infringe any intellectual property rights or any other rights of any third party regarding such information or data. ROHM shall not be in any way responsible or liable for infringement of any intellectual property rights or other damages arising from use of such information or data.:
2. No license, expressly or implied, is granted hereby under any intellectual property rights or other rights of ROHM or any third parties with respect to the information contained in this document.

**Other Precaution**

1. This document may not be reprinted or reproduced, in whole or in part, without prior written consent of ROHM.
2. The Products may not be disassembled, converted, modified, reproduced or otherwise changed without prior written consent of ROHM.
3. In no event shall you use in any way whatsoever the Products and the related technical information contained in the Products or this document for any military purposes, including but not limited to, the development of mass-destruction weapons.
4. The proper names of companies or products described in this document are trademarks or registered trademarks of ROHM, its affiliated companies or third parties.

**General Precaution**

1. Before you use our Products, you are requested to carefully read this document and fully understand its contents. ROHM shall not be in any way responsible or liable for failure, malfunction or accident arising from the use of any ROHM's Products against warning, caution or note contained in this document.
2. All information contained in this document is current as of the issuing date and subject to change without any prior notice. Before purchasing or using ROHM's Products, please confirm the latest information with a ROHM sales representative.
3. The information contained in this document is provided on an "as is" basis and ROHM does not warrant that all information contained in this document is accurate and/or error-free. ROHM shall not be in any way responsible or liable for any damages, expenses or losses incurred by you or third parties resulting from inaccuracy or errors of or concerning such information.

## Looking for pricing, stock, or lifecycle information?

Click below to explore more details on WIN SOURCE:

- [View BU7985KVT on WIN SOURCE](#)
- [Rohm Semiconductor Information](#)

## Optimize Your Supply Chain with WIN SOURCE Solutions

- ✓ Global Sourcing Solution
- ✓ Obsolete Management
- ✓ Cost Control Management
- ✓ Shortage Management
- ✓ Alternative Solution
- ✓ Excess Inventory Management