



**THE DATASHEET OF
SLB9665TT20FW563XUMA3**



OPTIGA™ TPM SLB 9665 TPM2.0

Trusted Platform Module

Data Sheet

Devices

- SLB 9665VQ2.0
- SLB 9665XQ2.0
- SLB 9665TT2.0
- SLB 9665XT2.0

Key Features

- Compliant to TPM Main Specification, Family "2.0", Level 00, Revision 01.16 (see [3])
- LPC interface
- Meets Intel TXT, Microsoft Windows and Google Chromebook certification criteria for successful platform qualification
- Random Number Generator (RNG) according to NIST SP800-90A
- Full personalization with Endorsement Key (EK) and EK certificate
- Standard (-20..+85°C) and enhanced temperature range (-40..+85°C)
- TSSOP-28 and VQFN-32 package
- Pin-compatible to SLB 9660
- Optimized for battery operated devices: low standby power consumption (typ. 150µA)
- 24 PCRs (SHA-1 or SHA-256)
- 7206 Byte free NV memory
- Up to 3 loaded sessions (TPM_PT_HR_LOADED_MIN)
- Up to 64 active sessions (TPM_PT_ACTIVE_SESSIONS_MAX)
- Up to 3 loaded transient Objects (TPM_PT_HR_TRANSIENT_MIN)
- Up to 7 loaded persistent Objects (TPM_PT_HR_PERSISTENT_MIN)
- Up to 8 NV counters
- Up to 1 kByte for command parameters and response parameters
- Up to 768 Byte for NV read or NV write
- 1280 Byte I/O buffer
- Built-in support by Linux Kernel Version 3.10 and higher

About this document

Scope and purpose

This data sheet describes the OPTIGA™ TPM SLB 9665 TPM2.0 Trusted Platform Module together with its features, functionality and programming interface.

Intended audience

This data sheet is primarily intended for system developers.

Table of contents

	Table of contents	3
	List of figures	4
	List of tables	5
1	LPC Interface	6
1.1	SYNC Field Usage	6
1.2	Localities	6
1.3	Power Management	6
1.4	LPC Access Rights	6
2	Device Types / Ordering Information	8
3	Pin Description	9
3.1	Typical Schematic	12
4	Electrical Characteristics	13
4.1	Absolute Maximum Ratings	13
4.2	Functional Operating Range	13
4.3	DC Characteristics	14
4.4	AC Characteristics	16
4.5	Timing	16
5	Package Dimensions (TSSOP)	17
5.1	Packing Type	17
5.2	Recommended Footprint	18
5.3	Chip Marking	18
6	Package Dimensions (VQFN)	19
6.1	Packing Type	19
6.2	Recommended Footprint	19
6.3	Chip Marking	20
	References	21
	Terminology	22
	Licenses and Notices	23

List of figures

List of figures

Figure 1	Pinout of the SLB 9665TT2.0 / SLB 9665XT2.0 (PG-TSSOP-28-2 Package, Top View)	9
Figure 2	Pinout of the SLB 9665VQ2.0 / SLB 9665XQ2.0 (PG-VQFN-32-13 Package, Top View).....	9
Figure 3	Typical Schematic	12
Figure 4	LRESET# Timing	16
Figure 5	Package Dimensions PG-TSSOP-28-2	17
Figure 6	Tape & Reel Dimensions PG-TSSOP-28-2	17
Figure 7	Recommended Footprint PG-TSSOP-28-2	18
Figure 8	Chip Marking PG-TSSOP-28-2	18
Figure 9	Package Dimensions PG-VQFN-32-13	19
Figure 10	Tape & Reel Dimensions PG-VQFN-32-13	19
Figure 11	Recommended Footprint PG-VQFN-32-13	19
Figure 12	Chip Marking PG-VQFN-32-13	20

List of tables

List of tables

Table 1	LT Register Access Matrix	6
Table 2	Device Configuration	8
Table 3	Buffer Types	9
Table 4	I/O Signals	10
Table 5	Power Supply	11
Table 6	Not Connected	12
Table 7	Absolute Maximum Ratings	13
Table 8	Functional Operating Range	13
Table 9	Current Consumption	14
Table 10	DC Characteristics for non-LPC Pins	15
Table 11	DC Characteristics for LPC Pins	15
Table 12	AC Characteristics	16

LPC Interface

1 LPC Interface

The OPTIGA™ TPM SLB 9665 features the Low Pin Count (LPC) interface (for a specification, please refer to [1]). From the cycle types defined in the mentioned specification, only the TPM-type cycles (read and write) are supported. All accesses with different cycle types are ignored by the device.

1.1 SYNC Field Usage

Since the legacy interface is not supported anymore, the OPTIGA™ TPM SLB 9665 will never generate SYNC ERRORS on the LPC. It will either acknowledge a cycle with SYNC OK or use a “Long Wait” SYNC field to enlarge a cycle (that means, inserting wait states on the bus).

1.2 Localities

The interface explicitly does not support standard IO cycles (read and write). This implies that IO-mapped addressing of the device is not possible; only accesses via the locality-based TPM-type cycles are possible which also means that “locality none” as defined in [4] is not supported as well.

For a detailed description of the locality addressing scheme and the registers located in each locality, please refer to [4] as well.

1.3 Power Management

The OPTIGA™ TPM SLB 9665 does not support the LPC power down signal (signal $\overline{\text{LPCPD}}$) or the clock run protocol (signal $\overline{\text{CLKRUN}}$). Power management is handled internally; no explicit power-down or standby mode is available. The device automatically enters a low-power state after each successful command/response transaction. If a transaction is started on the LPC bus from the host platform, the device will wake immediately and will return to the low power idle mode 50 ms after the last TPM command has been executed.

1.4 LPC Access Rights

The registers located in the address space of the OPTIGA™ TPM SLB 9665 are described in the respective TCG document (please refer to [4]). The registers READFIFO and WRITEFIFO mentioned in Table 1 below refer to the DATAFIFO register, the names are used to state whether this register is read or written.

Each register has its own access rights which describe if the register is updated on a write or can be read if the associated ACTIVE.LOCALITY is set respectively not set. If the access cycle is not accepted by the TPM, it will be master aborted (no LPC SYNC cycle will be generated and no action is done on the internal registers). Table 1 shows which operation is done by the TPM on each register depending on the ACTIVE.LOCALITY bit.

Note: In Table 1, “abort” means that no valid SYNC is generated when a cycle is seen by the interface which shall be aborted. The data present in an aborted write access cycle does not change the addressed register.

Table 1 LT Register Access Matrix

	ACTIVE.LOCALITY set for this locality		ACTIVE.LOCALITY set for different LOCALITY		ACTIVE.LOCALITY not set	
	READ	WRITE	READ	WRITE	READ	WRITE
STS	read	write	abort	abort	abort	abort
INT.ENABLE	read	write	read	abort	read	abort
INT.VECTOR	read	write	read	abort	read	abort

LPC Interface

Table 1 LT Register Access Matrix (continued)

	ACTIVE.LOCALITY set for this locality		ACTIVE.LOCALITY set for different LOCALITY		ACTIVE.LOCALITY not set	
	READ	WRITE	READ	WRITE	READ	WRITE
INT.STATUS	read	reset interrupt	read	abort	read	abort
INT.CAPABILITY	read	- (abort)	read	- (abort)	read	- (abort)
ACCESS	read	write	read	write	read	write
READFIFO	read ¹⁾	abort	abort	abort	abort	abort
WRITEFIFO	abort	write	abort	abort	abort	abort
Configuration Registers	read	write	read	abort	read	abort
HASH.START	abort	write	abort	abort	abort	write ²⁾
HASH.DATA	abort	write	abort	abort	abort	abort
HASH.END	abort	write ³⁾	abort	abort	abort	abort

1) If STS.DATA.AVAIL is not set, this access is 'abort'.

2) The write to HASH.START sets ACCESS.ACTIVE.LOCALITY of locality 4.

3) The write to HASH.END is an implicit release of the TPM (like a '1'-write to the ACCESS.ACTIVE.LOCALITY bit of locality 4).

2 Device Types / Ordering Information

The OPTIGA™ TPM SLB 9665 product family features devices with different packages. [Table 2](#) shows the different versions. Please check the latest “Errata and Updates” document of the OPTIGA™ TPM SLB 9665 for availability of these versions.

Table 2 Device Configuration

Device Name	Package	Remarks
SLB 9665VQ2.0	PG-VQFN-32-13	Standard temperature range
SLB 9665XQ2.0	PG-VQFN-32-13	Enhanced temperature range
SLB 9665TT2.0	PG-TSSOP-28-2	Standard temperature range
SLB 9665XT2.0	PG-TSSOP-28-2	Enhanced temperature range

Pin Description

3 Pin Description

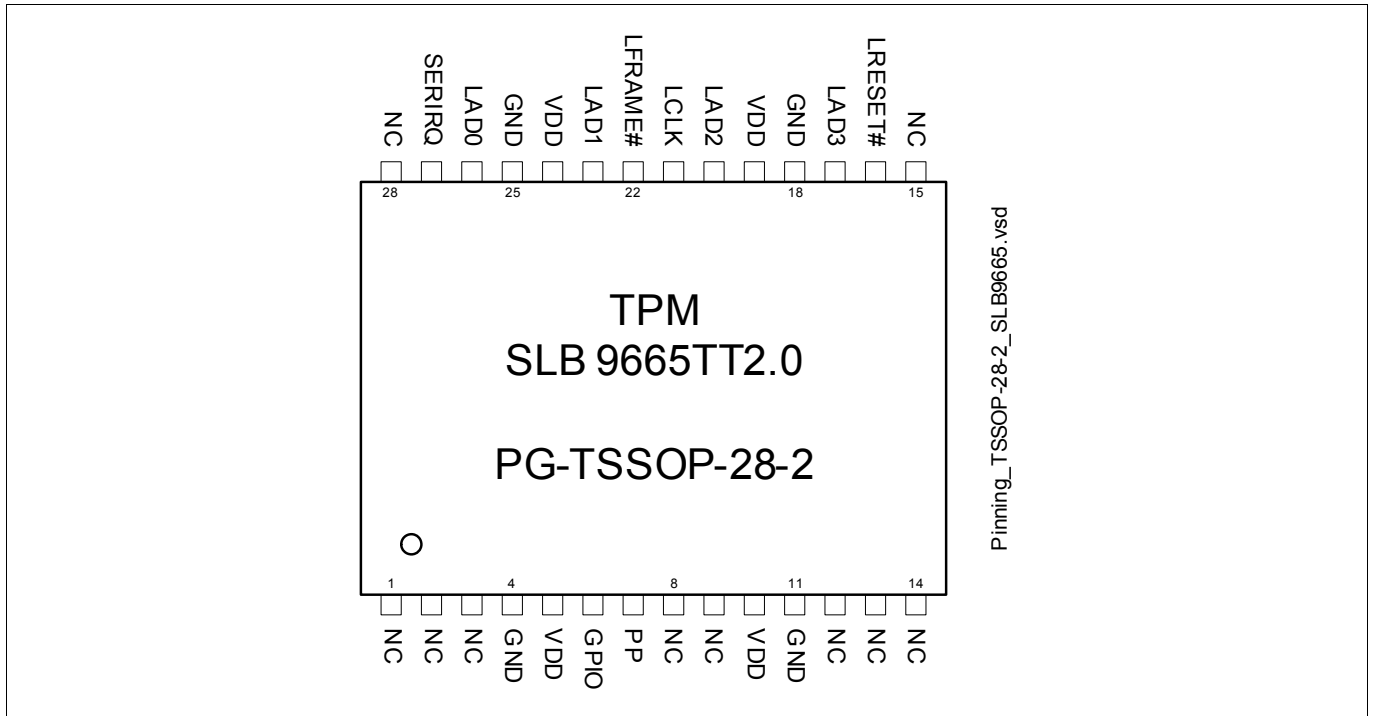

Figure 1 Pinout of the SLB 9665TT2.0 / SLB 9665XT2.0 (PG-TSSOP-28-2 Package, Top View)

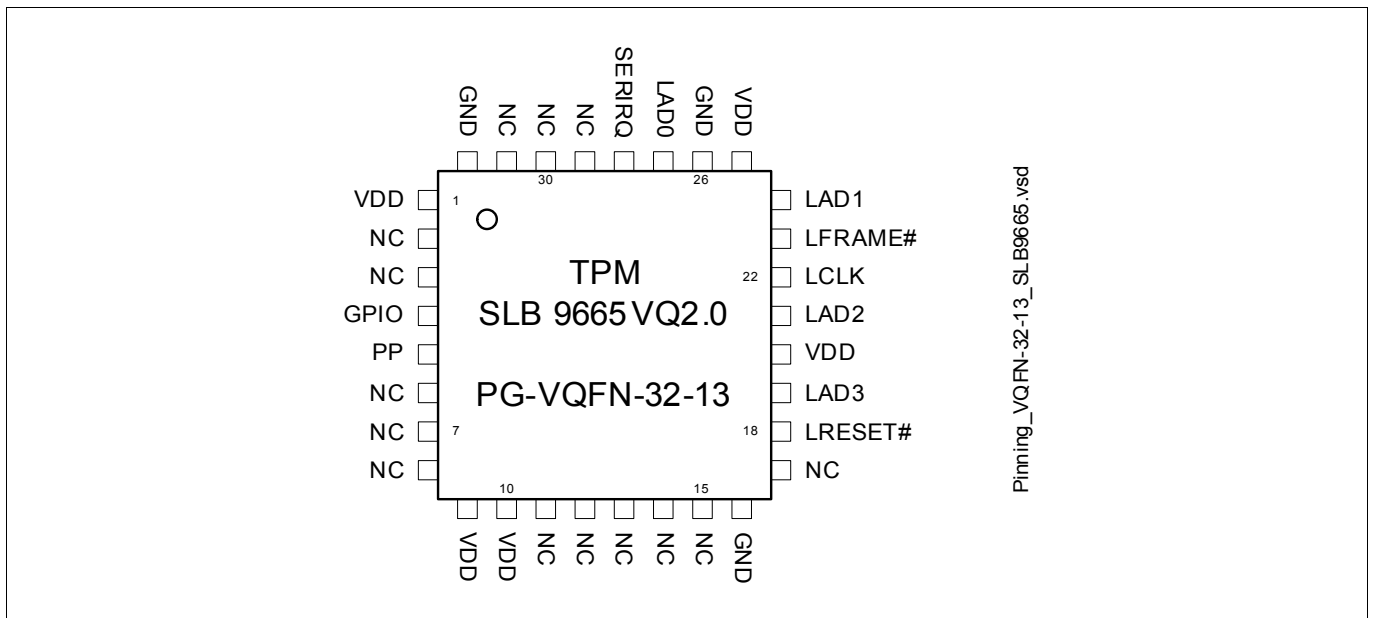

Figure 2 Pinout of the SLB 9665VQ2.0 / SLB 9665XQ2.0 (PG-VQFN-32-13 Package, Top View)

Table 3 Buffer Types

Buffer Type	Description
TS	Tri-State pin

Pin Description

Table 3 Buffer Types (continued)

Buffer Type	Description
ST	Schmitt-Trigger pin
OD	Open-Drain pin

Table 4 I/O Signals

Pin Number		Name	Pin Type	Buffer Type	Function
PG-TSSOP-28-2	PG-VQFN-32-13				
26	27	LAD0	I/O	TS	LPC Address/Data Bit 0 Multiplexed LPC command, address and data bus. Connect these pins to the LAD[3:0] pins of the LPC host.
23	24	LAD1	I/O	TS	LPC Address/Data Bit 1 see description of LAD0 above.
20	21	LAD2	I/O	TS	LPC Address/Data Bit 2 see description of LAD0 above.
17	19	LAD3	I/O	TS	LPC Address/Data Bit 3 see description of LAD0 above.
22	23	LFRAME#	I	ST	LPC Framing Signal LPC framing signal. This pin is connected to the LPC LFRAME# signal and indicates the start of a new cycle on the LPC bus or the termination of a broken cycle. The signal is active low.
21	22	LCLK	I	ST	Clock Input This pin provides the external clock for the chip and is typically connected to the PCI clock of the host. The clock frequency range is 1 MHz - 33 MHz (nominal).
16	18	LRESET#	I	ST	Reset External reset signal. Asserting this pin unconditionally resets the device. The signal is active low and is typically connected to the PCIRST# signal of the host.
6	4	GPIO	I/O	OD	General Purpose I/O This pin is a general purpose I/O pin. It is defined as GPIO-Express-00, please refer to [4] and the PCI-SIG ECN "Trusted Configuration Space for PCI Express". This pin may be left unconnected; however, to minimize power consumption, it shall be connected to a fixed level (either GND or VDD) via an external resistor (4.7 kΩ..10 kΩ).

Pin Description

Table 4 I/O Signals (continued)

Pin Number		Name	Pin Type	Buffer Type	Function
PG-TSSOP-28-2	PG-VQFN-32-13				
7	5	PP	I	ST	<p>Physical Presence</p> <p>This pin indicates physical presence; for usage of this signal, please refer to the TCG specification v1.2. The TPM 2.0 device does not use this functionality.</p> <p>For compatibility reasons (downgrade capability to a TPM 1.2), the pin should be connected to a jumper. The standard position of the jumper should connect the pin to GND. If the pin is connected to VDD, some special commands are enabled for a TPM 1.2.</p> <p>This pin does not have an internal pull-up or pulldown resistor and must not be left floating if it is used for physical presence detection via hardware pin.</p> <p>If physical presence detection via hardware pin is not used, this pin may be left unconnected; however, to minimize power consumption, it shall be connected to a fixed level (either GND or VDD) directly or via an external resistor.</p>
27	28	SERIRQ	I/O	TS	<p>Serial Interrupt Request</p> <p>Interrupt request signal, uses the serial interrupt request protocol (see [2]). Connect to the LPC host.</p>

Table 5 Power Supply

Pin Number		Name	Pin Type	Buffer Type	Function
PG-TSSOP-28-2	PG-VQFN-32-13				
5, 10, 19, 24	1, 9, 10, 20, 25	VDD	PWR	—	<p>Power Supply</p> <p>All VDD pins must be connected externally and should be bypassed to GND via 100 nF capacitors.</p>
4, 11, 18, 25	16, 26, 32	GND	GND	—	<p>Ground</p> <p>All GND pins must be connected externally.</p>

Pin Description

Table 6 Not Connected

Pin Number		Name	Pin Type	Buffer Type	Function
PG-TSSOP-28-2	PG-VQFN-32-13				
1, 2, 3, 8, 12, 13, 14, 15, 28	2, 3, 6, 7, 11, 12, 13, 14, 15, 17, 29, 30, 31	NC	NU	—	Not Connected All pins must not be connected externally (must be left floating).
9	8	NC	NU	—	Not Connected This pin may be connected to the Reset signal (for backward compatibility) or may be left floating.

3.1 Typical Schematic

Figure 3 shows the typical schematic for the OPTIGA™ TPM SLB 9665. The power supply pins should be bypassed to GND with capacitors located close to the device. The physical presence input may be connected to a jumper as shown in the schematic; or it may be driven by other devices (this is application- or platform-dependent).

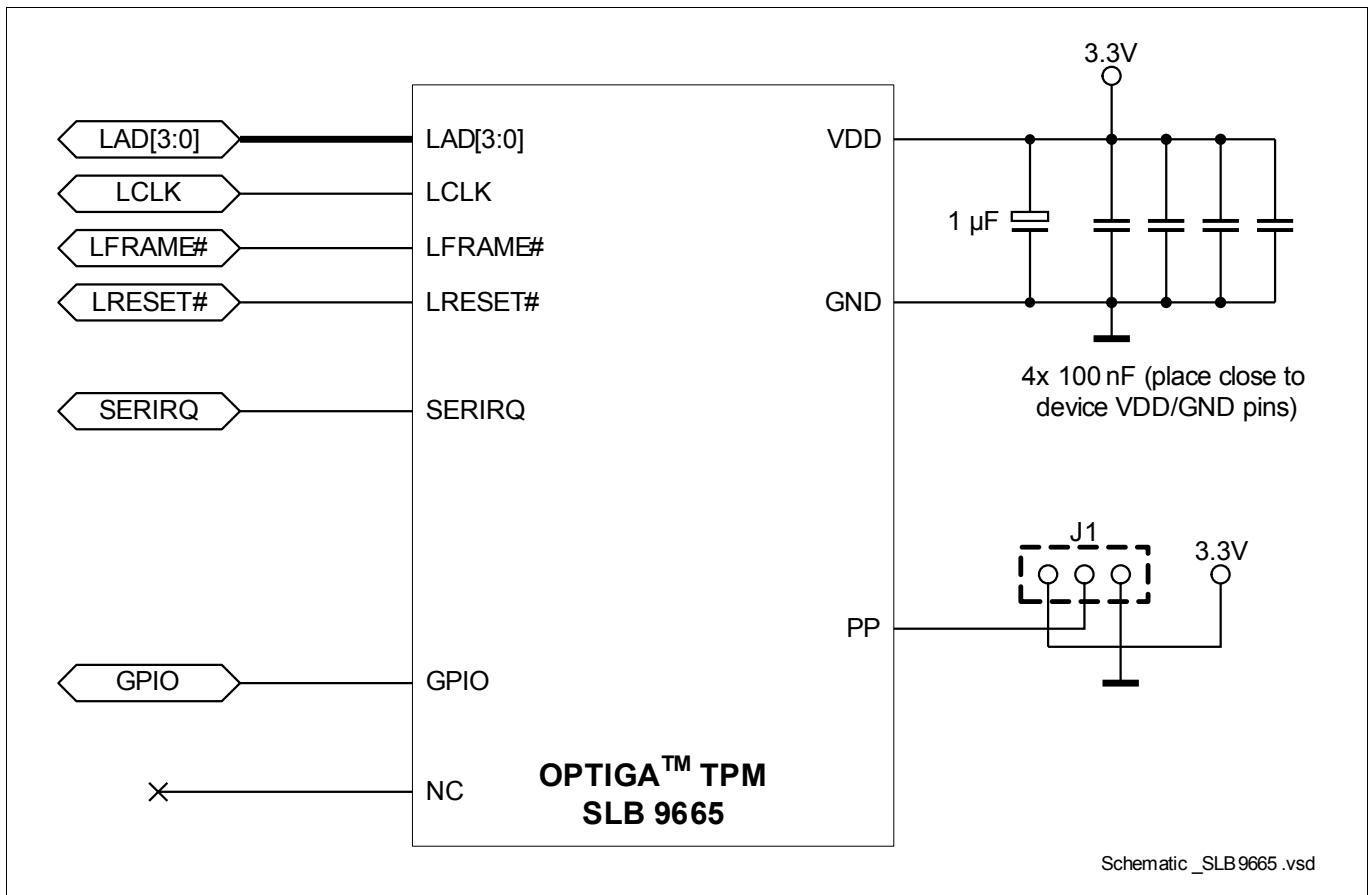

Figure 3 Typical Schematic

Electrical Characteristics

4 Electrical Characteristics

This chapter lists the maximum and operating ranges for various electrical and timing parameters.

4.1 Absolute Maximum Ratings

Table 7 Absolute Maximum Ratings

Parameter	Symbol	Values			Unit	Note or Test Condition
		Min.	Typ.	Max.		
Supply Voltage	V_{DD}	-0.3	–	3.6	V	–
Voltage on any pin	V_{max}	-0.3	–	$V_{DD}+0.3$	V	–
Ambient temperature	T_A	-20	–	85	°C	Standard temperature devices
Ambient temperature	T_A	-40	–	85	°C	Enhanced temperature devices
Storage temperature	T_S	-40	–	125	°C	–
ESD robustness HBM: 1.5 kΩ, 100 pF	$V_{ESD,HBM}$	–	–	2000	V	According to EIA/JESD22-A114-B
ESD robustness	$V_{ESD,CDM}$	–	–	500	V	According to ESD Association Standard STM5.3.1 - 1999
Latchup immunity	I_{latch}			100	mA	According to EIA/JESD78

Attention: Stresses above the max. values listed here may cause permanent damage to the device. Exposure to absolute maximum rating conditions for extended periods may affect device reliability. Maximum ratings are absolute ratings; exceeding only one of these values may cause irreversible damage to the integrated circuit.

4.2 Functional Operating Range

Table 8 Functional Operating Range

Parameter	Symbol	Values			Unit	Note or Test Condition
		Min.	Typ.	Max.		
Supply Voltage	V_{DD}	3.0	3.3	3.6	V	–
Ambient temperature	T_A	-20	–	85	°C	Standard temperature devices
Ambient temperature	T_A	-40	–	85	°C	Enhanced temperature devices
Useful lifetime		–	–	10	y	
Operating lifetime		–	–	10	y	
Average T_A over lifetime		–	55	–	°C	

Electrical Characteristics

4.3 DC Characteristics

$T_A = 25^\circ\text{C}$, $V_{DD} = 3.3\text{V} \pm 0.3\text{V}$ unless otherwise noted

Table 9 Current Consumption

Parameter	Symbol	Values			Unit	Note or Test Condition
		Min.	Typ.	Max.		
Current consumption in Active mode	I_{VDD_Active}		2.5	25	mA	Assuming operating state S0 , that means active. Note that since the device is mostly in an internal sleep state in a “typical” application, the typical average current consumption is far less than the maximum value. It is assumed that in a normal environment, the device is in an internal sleep state for approximately 90% of the operating time of the platform.
Current consumption in Sleep mode	I_{VDD_Sleep}		0.9		mA	Pins LRESET#, LFRAME#, LADn, SERIRQ = V_{DD} . Assuming operating state S0 with active clock. No ongoing internal TPM operation. The device is in an internal sleep state.
Current consumption in Sleep mode with stopped clock	$I_{VDD_Sleep_CS}$		150		μA	Pins LRESET#, LFRAME#, LADn, SERIRQ = V_{DD} and LCLK = GND. Assuming operating state S3 with clock stopped. ¹⁾
Current consumption in Low Power Idle mode	I_{VDD_LPI}		1.8		mA	Pins LRESET#, LFRAME#, LADn, SERIRQ = V_{DD} . Assuming operating state S0 with active clock. No ongoing internal TPM operation. The device is in an internal low power idle state.
Current consumption in Low Power Idle mode with stopped clock	$I_{VDD_LPI_CS}$		1.3		mA	Pins LRESET#, LFRAME#, LADn, SERIRQ = V_{DD} and LCLK = GND. Assuming operating state S3 with clock stopped. ¹⁾

1) Obviously, this value is zero if the TPM is not powered in S3 state (this is platform dependent).

Note: Current consumption does not include any currents flowing through resistive loads on output pins! For the definition of power/operating states, please refer to the ACPI standard.

Note: Low power idle mode will be entered 50 ms after the last TPM command has been executed.

Electrical Characteristics

Table 10 DC Characteristics for non-LPC Pins

Parameter	Symbol	Values			Unit	Note or Test Condition
		Min.	Typ.	Max.		
Input voltage high	V_{IH}	$0.7 V_{DD}$		V_{DD}	V	GPIO and PP pins
Input voltage low	V_{IL}	0		$0.3 V_{DD}$	V	GPIO and PP pins
Input high leakage current	I_{IH}	-15		15	μA	$V_{IN} = V_{DD}$, GPIO and PP pins
Input low leakage current	I_{IL}	-15		15	μA	$V_{IN} = 0V$, GPIO and PP pins
Output high voltage	V_{OH}	$V_{DD}-0.3$			V	$I_{OH} = 1mA$, Pin GPIO
Output low voltage	V_{OL}			0.3	V	$I_{OL} = 1mA$, Pin GPIO

Table 11 DC Characteristics for LPC Pins

Parameter	Symbol	Values			Unit	Note or Test Condition
		Min.	Typ.	Max.		
Input voltage high	V_{IH}	$0.5 V_{DD}$		$V_{DD}+0.3$	V	All signal pins except GPIO and PP
Input voltage low	V_{IL}	-0.3		$0.28 V_{DD}$	V	All signal pins except GPIO and PP
Input high leakage current	I_{IH}	-10		10	μA	$V_{IN} = V_{DD}$, all signal pins except GPIO and PP
Input low leakage current	I_{IL}	-10		10	μA	$V_{IN} = 0V$, all signal pins except GPIO and PP
Output high voltage	V_{OH}	$0.9 V_{DD}$			V	$I_{OH} = -500\mu A$, pins LAD[3:0] and SERIRQ
Output low voltage	V_{OL}			$0.1 V_{DD}$	V	$I_{OL} = 1.5mA$, pins LAD[3:0] and SERIRQ

Electrical Characteristics

4.4 AC Characteristics

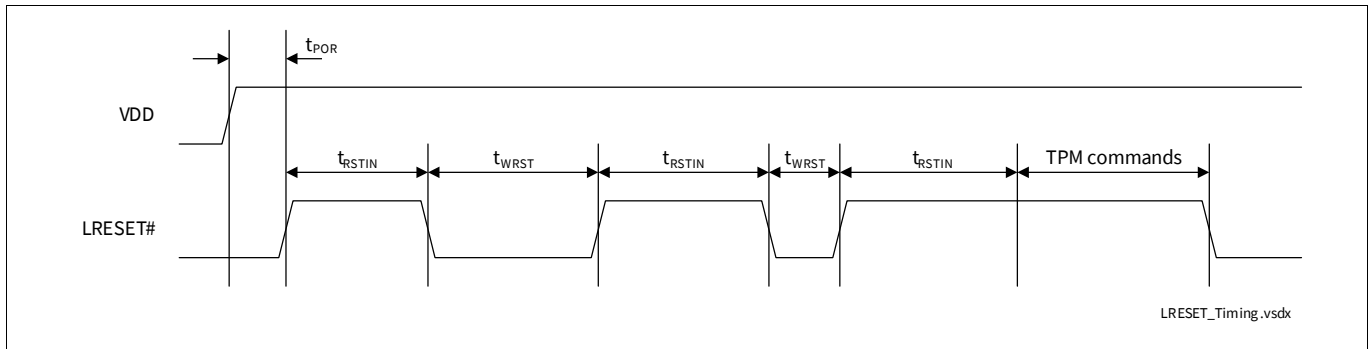

Figure 4 LRESET# Timing

Table 12 AC Characteristics

Parameter	Symbol	Values			Unit	Note or Test Condition
		Min.	Typ.	Max.		
Cold (Power-On) Reset	t_{POR}	80			μs	see Section 4.5
Warm Reset	t_{WRST}	10			μs	see Section 4.5
Reset Inactive Time	t_{RSTIN}	30			ms	see Section 4.5

4.5 Timing

Some pads are disabled after deassertion of the reset signal for up to 500 μs . This is especially important for the SERIRQ signal; after deassertion of the reset signal, this signal is only valid after that time has expired.

The OPTIGA™ TPM SLB 9665 features a sophisticated protection mechanism against dictionary attacks on TPM-based authorization data. Basically, the device counts the number of failed authorization attempts in a counter which is located in the non-volatile memory. An attacker who has physical access to the device could try to circumvent that mechanism by resetting the device after the authorization attempt but before the updated failure counter has been written into the NVM.

Certain countermeasures have been added to the OPTIGA™ TPM SLB 9665. In certain time windows during power-on or warm boot of the device, such reset events might influence the dictionary attack counters and trigger other security mechanisms as well. In worst case, this might trigger special security defense modes from which a recovery is very complex or even not possible.

To avoid that the OPTIGA™ TPM SLB 9665 reaches such a security defense state, the LRESET# signal must not be asserted in certain time windows. After the deassertion of the LRESET# signal, the system should wait for a minimum time of t_{RSTIN} before asserting LRESET# again (see [Figure 4](#) and [Table 12](#)).

TPM commands should only be started after t_{RSTIN} has expired (see [Figure 4](#) again). If a TPM command is running, LRESET# should not be asserted; otherwise, this might also trigger some security functions. When the TPM shall be reset, the command TPM2_Shutdown should be issued before the assertion of the LRESET# signal.

Package Dimensions (TSSOP)

5 Package Dimensions (TSSOP)

All dimensions are given in millimeters (mm) unless otherwise noted. The packages are “green” and RoHS compliant.

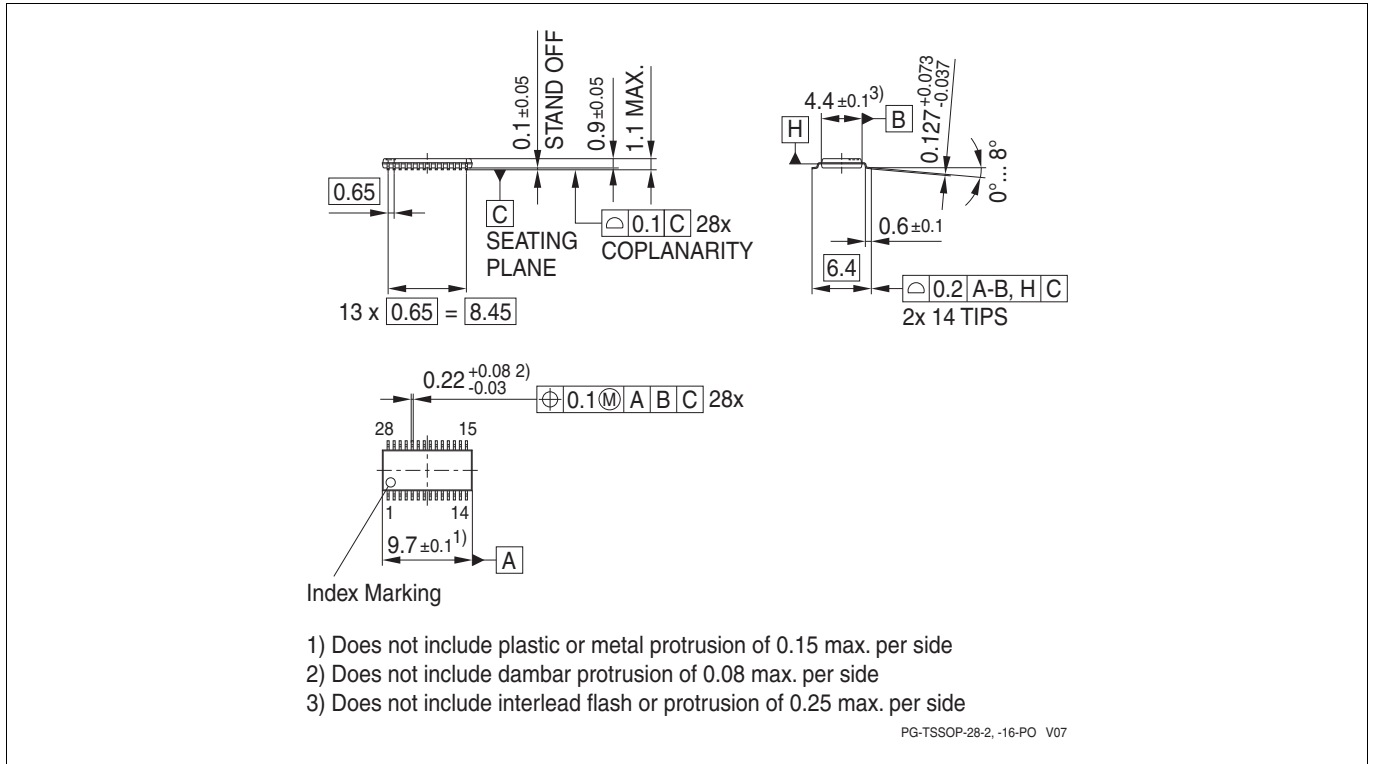

Figure 5 Package Dimensions PG-TSSOP-28-2

5.1 Packing Type

PG-TSSOP-28-2: Tape & Reel (reel diameter 330mm), 3000 pcs. per reel

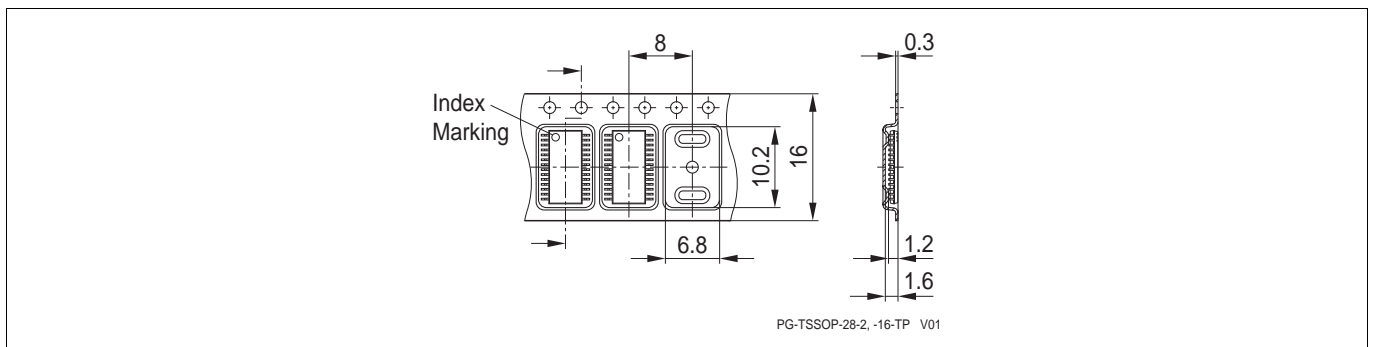

Figure 6 Tape & Reel Dimensions PG-TSSOP-28-2

Package Dimensions (TSSOP)

5.2 Recommended Footprint

Controlling dimension is millimeters (mm).

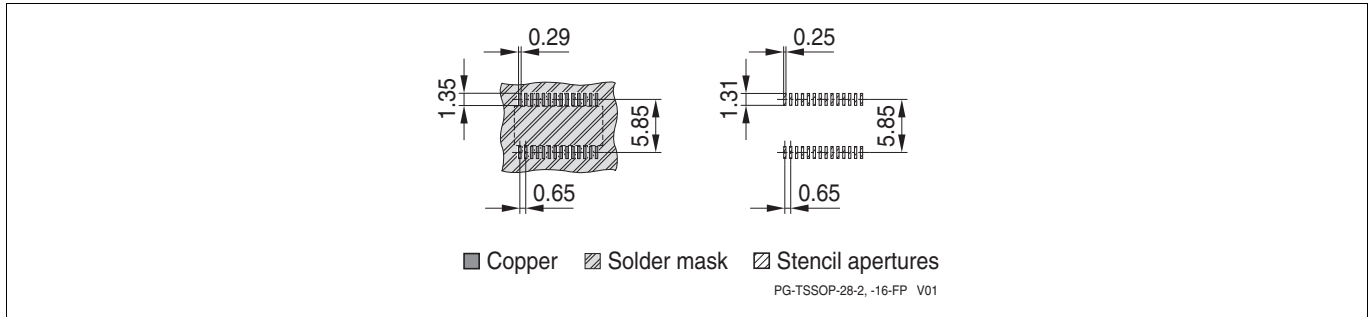

Figure 7 Recommended Footprint PG-TSSOP-28-2

5.3 Chip Marking

Line 1: SLB9665TT20 or SLB9665XT20, see Table 2

Line 2: G <datecode> KMC, <K> indicates assembly site code, <MC> indicates mold compound code

Line 3: 00 <Lot number>, the 00 is an internal FW indication (only at manufacturing due to field upgrade option)

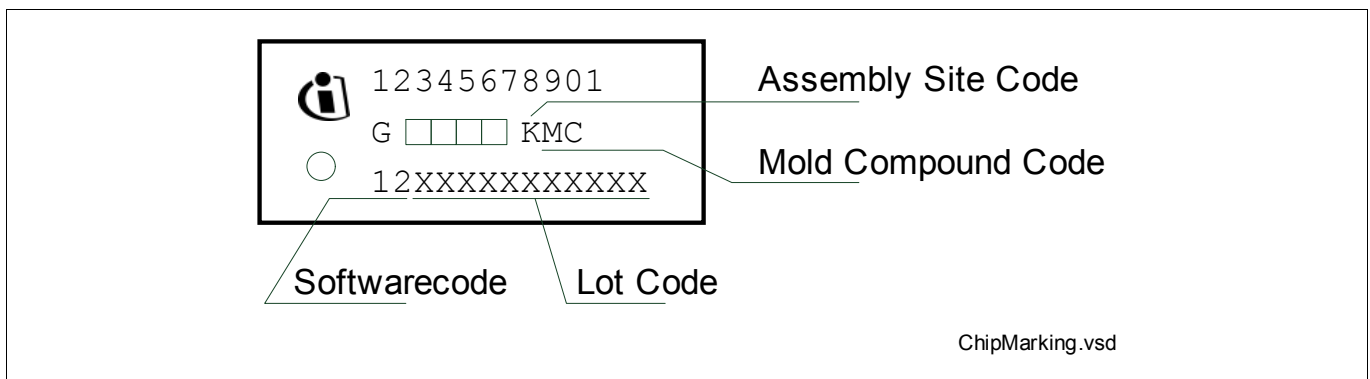

Figure 8 Chip Marking PG-TSSOP-28-2

For details and recommendations regarding assembly of packages on PCBs, please refer to <http://www.infineon.com/cms/en/product/technology/packages/>

Package Dimensions (VQFN)

6 Package Dimensions (VQFN)

All dimensions are given in millimeters (mm) unless otherwise noted. The packages are “green” and RoHS compliant.

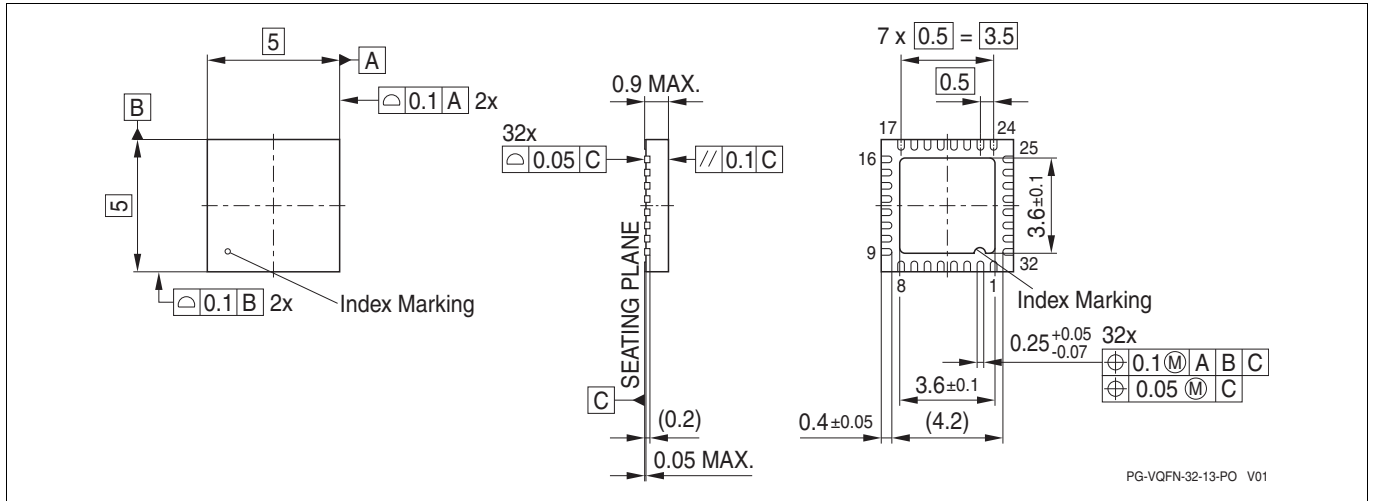

Figure 9 Package Dimensions PG-VQFN-32-13

6.1 Packing Type

PG-VQFN-32-13: Tape & Reel (reel diameter 330mm), 5000 pcs. per reel

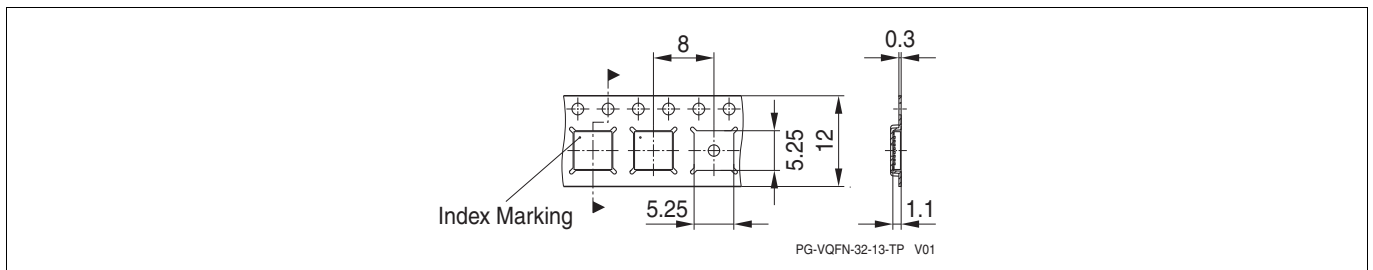

Figure 10 Tape & Reel Dimensions PG-VQFN-32-13

6.2 Recommended Footprint

Figure 11 shows the recommended footprint for the PG-VQFN-32-13 package. The exposed pad of the package is internally connected to GND. It shall be connected to GND externally as well.

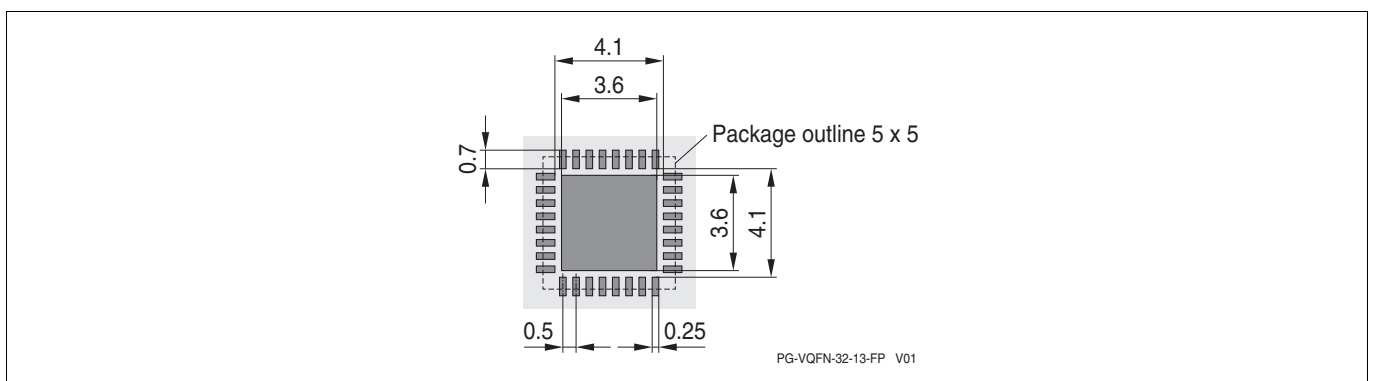

Figure 11 Recommended Footprint PG-VQFN-32-13

Package Dimensions (VQFN)

6.3 Chip Marking

Line 1: SLB9665

Line 2: VQ20 yy or XQ20 yy (see [Table 2](#)), the <yy> is an internal FW indication (only at manufacturing due to field upgrade option)

Line 3: <Lot number> H <datecode>

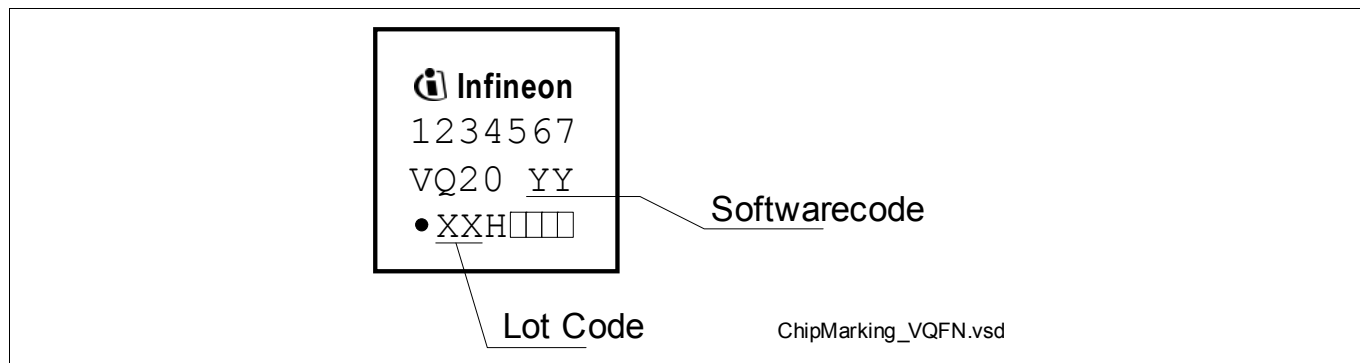

Figure 12 Chip Marking PG-VQFN-32-13

For details and recommendations regarding assembly of packages on PCBs, please refer to <http://www.infineon.com/cms/en/product/technology/packages/>

References

References

- [1] —, “Low Pin Count (LPC) Interface Specification”, Version 1.1, Intel
- [2] —, “Serialized IRQ Support for PCI Systems”, Version 6.0, September 1, 1995, Cirrus Logic et al.
- [3] —, “Trusted Platform Module Library (Part 1-4)”, Family 2.0, Level 00, Rev. 01.16, October 30, 2014, TCG
- [4] —, “TCG PC Client Specific Platform TPM Profile (PTP) Specification”, Family 2.0, Level 00, Rev. 43, January 26, 2015, TCG

Terminology

Terminology

ESW	Embedded Software
HMAC	Hashed Message Authentication Code
LPC	Low Pin Count (bus)
PCR	Platform Configuration Register
PUBEK	Public Endorsement Key
SCP	Symmetric Crypto Processor
TCG	Trusted Computing Group
TPM	Trusted Platform Module
TSS	TCG Software Stack

Licenses and Notices

The following License and Notice Statements are reproduced from [3].

Licenses and Notices

1. Copyright Licenses:

Trusted Computing Group (TCG) grants to the user of the source code in this specification (the "Source Code") a worldwide, irrevocable, nonexclusive, royalty free, copyright license to reproduce, create derivative works, distribute, display and perform the Source Code and derivative works thereof, and to grant others the rights granted herein. The TCG grants to the user of the other parts of the specification (other than the Source Code) the rights to reproduce, distribute, display, and perform the specification solely for the purpose of developing products based on such documents.

2. Source Code Distribution Conditions:

Redistributions of Source Code must retain the above copyright licenses, this list of conditions and the following disclaimers.

Redistributions in binary form must reproduce the above copyright licenses, this list of conditions and the following disclaimers in the documentation and/or other materials provided with the distribution.

3. Disclaimers:

THE COPYRIGHT LICENSES SET FORTH ABOVE DO NOT REPRESENT ANY FORM OF LICENSE OR WAIVER, EXPRESS OR IMPLIED, BY ESTOPPEL OR OTHERWISE, WITH RESPECT TO PATENT RIGHTS HELD BY TCG MEMBERS (OR OTHER THIRD PARTIES) THAT MAY BE NECESSARY TO IMPLEMENT THIS SPECIFICATION OR OTHERWISE. Contact TCG Administration (admin@trustedcomputinggroup.org) for information on specification licensing rights available through TCG membership agreements.

THIS SPECIFICATION IS PROVIDED "AS IS" WITH NO EXPRESS OR IMPLIED WARRANTIES WHATSOEVER, INCLUDING ANY WARRANTY OF MERCHANTABILITY OR FITNESS FOR A PARTICULAR PURPOSE, ACCURACY, COMPLETENESS, OR NONINFRINGEMENT OF INTELLECTUAL PROPERTY RIGHTS, OR ANY WARRANTY OTHERWISE ARISING OUT OF ANY PROPOSAL, SPECIFICATION OR SAMPLE.

Without limitation, TCG and its members and licensors disclaim all liability, including liability for infringement of any proprietary rights, relating to use of information in this specification and to the implementation of this specification, and TCG disclaims all liability for cost of procurement of substitute goods or services, lost profits, loss of use, loss of data or any incidental, consequential, direct, indirect, or special damages, whether under contract, tort, warranty or otherwise, arising in any way out of use or reliance upon this specification or any information herein.

Any marks and brands contained herein are the property of their respective owners.

Revision History

Page or Item	Subjects (major changes since previous revision)
Revision 1.2, 2018-09-21	
	Updated document template.
Revision 1.1, 2013-09-13	
	New template. Changed lifetime in Table 8 . Fixed pinning for PG-VQFN-32-13 package, affected pins are GPIO and PP . Added Section 4.4 and enhanced Section 4.5 .
Revision 1.0, 2013-07-19	
	Initial version.

Trademarks

All referenced product or service names and trademarks are the property of their respective owners.

Edition 2018-09-21

Published by

Infineon Technologies AG

81726 Munich, Germany

© 2018 Infineon Technologies AG.

All Rights Reserved.

Do you have a question about any aspect of this document?

Email:

security.chipcard.ics@infineon.com

IMPORTANT NOTICE

The information given in this document shall in no event be regarded as a guarantee of conditions or characteristics ("Beschaffheitsgarantie").

With respect to any examples, hints or any typical values stated herein and/or any information regarding the application of the product, Infineon Technologies hereby disclaims any and all warranties and liabilities of any kind, including without limitation warranties of non-infringement of intellectual property rights of any third party.

In addition, any information given in this document is subject to customer's compliance with its obligations stated in this document and any applicable legal requirements, norms and standards concerning customer's products and any use of the product of Infineon Technologies in customer's applications.

The data contained in this document is exclusively intended for technically trained staff. It is the responsibility of customer's technical departments to evaluate the suitability of the product for the intended application and the completeness of the product information given in this document with respect to such application.

For further information on technology, delivery terms and conditions and prices, please contact the nearest Infineon Technologies Office (www.infineon.com).



WARNINGS

Due to technical requirements products may contain dangerous substances. For information on the types in question please contact your nearest Infineon Technologies office.

Except as otherwise explicitly approved by Infineon Technologies in a written document signed by authorized representatives of Infineon Technologies, Infineon Technologies' products may not be used in any applications where a failure of the product or any consequences of the use thereof can reasonably be expected to result in personal injury.

Looking for pricing, stock, or lifecycle information?

Click below to explore more details on WIN SOURCE:

-  [View SLB9665TT20FW563XUMA3 on WIN SOURCE](#)
-  [Infineon Technologies Information](#)

Optimize Your Supply Chain with WIN SOURCE Solutions

-  Global Sourcing Solution
-  Obsolete Management
-  Cost Control Management
-  Shortage Management
-  Alternative Solution
-  Excess Inventory Management