

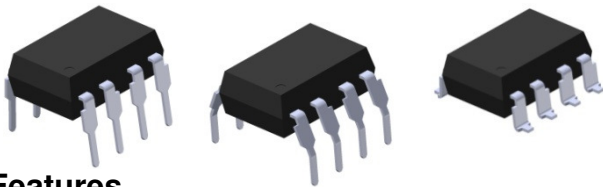

**THE DATASHEET OF
EL2601S1(TA)**



8 PIN DIP HIGH SPEED 10MBit/s LOGIC GATE PHOTOCOUPLER 6N137 EL26XX series



Features

- High speed 10Mbit/s
- 10kV/μs min. common mode transient immunity (EL2611)
- Guaranteed performance from -40 to 85°C
- Logic gate output
- High isolation voltage between input and output (Viso=5000 V rms)
- Pb free and RoHS compliant.
- UL approved (No. 214129)
- VDE approved (No. 132249)
- SEMKO approved
- NEMKO approved
- DEMKO approved
- FIMKO approved
- CSA approved (No. 2037145)

Description

The 6N137, EL2601 and EL2611 are consists of an infrared emitting diode optically coupled to a high speed integrated photo detector logic gate with a strobable output. It is packaged in a 8-pin DIP package and available in wide-lead spacing and SMD options.

Applications

- Ground loop elimination
- LSTTL to TTL, LSTTL or 5 volt CMOS
- Line receiver, data transmission
- Data multiplexing
- Switching power supplies
- Pulse transformer replacement
- Computer peripheral interface
- High speed logic ground isolation

Schematic

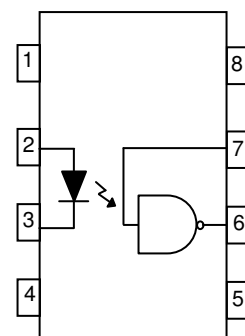

A 0.1 μF bypass capacitor must be connected between pins 8 and 5 *3

Pin Configuration

- 1, No Connection
- 2, Anode
- 3, Cathode
- 4, No Connection
- 5, Gnd
- 6, Vout
- 7, V_E
- 8, V_{CC}

Truth Table (Positive Logic)

Input	Enable	Output
H	H	L
L	H	H
H	L	H
L	L	H
H	NC	L
L	NC	H

Absolute Maximum Ratings (Ta=25°C)

	Parameter	Symbol	Rating	Unit
Input	Forward current	I_F	50	mA
	Enable input voltage Not exceed V_{CC} by more than 500mV	V_E	5.5	V
	Reverse voltage	V_R	5	V
	Power dissipation	P_D	100	mW
Output	Power dissipation	P_C	85	mW
	Output current	I_O	50	mA
	Output voltage	V_O	7.0	V
	Supply voltage	V_{CC}	7.0	V
	Output Power Dissipation	P_O	100	mW
	Isolation voltage ^{*1}	V_{ISO}	5000	V rms
	Operating temperature	T_{OPR}	-40 ~ +85	°C
	Storage temperature	T_{STG}	-55 ~ +125	°C
	Soldering temperature ^{*2}	T_{SOL}	260	°C

Notes:

*1 AC for 1 minute, R.H.= 40 ~ 60% R.H. In this test, pins 1, 2, 3 & 4 are shorted together, and pins 5, 6, 7 & 8 are shorted together.

*2 For 10 seconds.

Electrical Characteristics (Ta=-40 to 85 °C unless specified otherwise)

Input

Parameter	Symbol	Min.	Typ.	Max.	Unit	Condition
Forward voltage	V_F	-	1.4	1.8	V	$I_F = 10\text{mA}$
Reverse voltage	V_R	5.0	-	-	V	$I_R = 10\mu\text{A}$
Temperature coefficient of forward voltage	$\Delta V_F/\Delta T_A$	-	-1.8	-	mV/°C	$I_F = 10\text{mA}$
Input capacitance	C_{IN}	-	60	-	pF	$V_F = 0, f = 1\text{MHz}$

Output

Parameter	Symbol	Min	Typ.	Max.	Unit	Condition
High level supply current	I_{CCH}	-	7	10	mA	$I_F = 0\text{mA}, V_E = 0.5\text{V}, V_{CC} = 5.5\text{V}$
Low level supply current	I_{CCL}	-	9	13	mA	$I_F = 10\text{mA}, V_{CC} = 5.5\text{V}$
High level enable current	I_{EH}	-	-0.6	-1.6	mA	$V_E = 2.0\text{V}, V_{CC} = 5.5\text{V}$
Low level enable current	I_{EL}	-	-0.8	-1.6	mA	$V_E = 0.5\text{V}, V_{CC} = 5.5\text{V}$
High level enable voltage	V_{EH}	2.0	-	-	V	$I_F = 10\text{mA}, V_{CC} = 5.5\text{V}$
Low level enable voltage ⁴	V_{EL}	-	-	0.8	V	$I_F = 10\text{mA}, V_{CC} = 5.5\text{V}$

Transfer Characteristics (Ta=-40 to 85 °C unless specified otherwise)

Parameter	Symbol	Min	Typ.	Max.	Unit	Condition
HIGH Level Output Current	I_{OH}	-	2.1	100	μA	$V_{CC} = 5.5\text{V}, V_O = 5.5\text{V}, I_F = 250\mu\text{A}, V_E = 2.0\text{V}$
LOW Level Output Current	V_{OL}	-	0.35	0.6	V	$V_{CC} = 5.5\text{V}, I_F = 5\text{mA}, V_E = 2.0\text{V}, I_{OL} = 13\text{mA}$
Input Threshold Current	I_{FT}	-	2.5	5	mA	$V_{CC} = 5.5\text{V}, V_O = 0.6\text{V}, V_E = 2.0\text{V}, I_{OL} = 13\text{mA}$

Switching Characteristics ($T_a=-40$ to 85°C , $V_{CC}=5\text{V}$, $I_F=7.5\text{mA}$ unless specified otherwise)

Parameter	Symbol	Min	Typ.	Max.	Unit	Condition
Propagation delay time to output High level* ⁵ (Fig.12)	T_{PHL}	-	35	75	ns	$C_L = 15\text{pF}$, $R_L=350\Omega$, $T_A=25^\circ\text{C}$
Propagation delay time to output Low level* ⁶ (Fig.12)	T_{PLH}	-	40	75	ns	$C_L = 15\text{pF}$, $R_L=350\Omega$, $T_A=25^\circ\text{C}$
Pulse width distortion	$ T_{phl} - T_{plh} $	-	5	35	ns	$C_L = 15\text{pF}$, $R_L=350\Omega$
Output rise time* ⁷ (Fig.12)	tr	-	40	-	ns	$C_L = 15\text{pF}$, $R_L=350\Omega$
Output fall time* ⁸ (Fig.12)	tf	-	10	-	ns	$C_L = 15\text{pF}$, $R_L=350\Omega$

Switching Characteristics ($T_a=-40$ to 85°C , $V_{CC}=5\text{V}$, $I_F=7.5\text{mA}$ unless specified otherwise)

Parameter	Symbol	Min	Typ.	Max.	Unit	Condition
Enable Propagation Delay Time to Output High Level* ⁹ (Fig.13)	t_{ELH}	-	15	-	ns	$I_F = 7.5\text{mA}$, $V_{EH}=3.5\text{V}$, $C_L = 15\text{pF}$, $R_L=350\Omega$
Enable Propagation Delay Time to Output Low Level* ¹⁰ (Fig.13)	t_{EHL}	-	15	-	ns	$I_F = 7.5\text{mA}$, $V_{EH}=3.5\text{V}$, $C_L = 15\text{pF}$, $R_L=350\Omega$
Common Mode Transient Immunity at Logic High* ¹¹	6N137	-	-	-	V/ μS	$I_F = 7.5\text{mA}$, $V_{OH}=2.0\text{V}$, $R_L=350\Omega$, $T_A=25^\circ\text{C}$ $V_{CM}=10\text{Vp-p}$ (Fig.14)
	EL2601	5,000	-	-		$I_F = 7.5\text{mA}$, $V_{OH}=2.0\text{V}$, $R_L=350\Omega$, $T_A=25^\circ\text{C}$ $V_{CM}=50\text{Vp-p}$ (Fig.14)
	EL2611	10,000	-	-		$I_F = 7.5\text{mA}$, $V_{OH}=2.0\text{V}$, $R_L=350\Omega$, $T_A=25^\circ\text{C}$ $V_{CM}=400\text{Vp-p}$ (Fig.14)
	EL2611	20,000	-	-		$I_F = 7.5\text{mA}$, $V_{OH}=2.0\text{V}$, $R_L=350\Omega$, $T_A=25^\circ\text{C}$ $V_{CM}=400\text{Vp-p}$ (Fig.15)
Common Mode Transient Immunity at Logic Low* ¹²	6N137	-	-	-	V/ μS	$I_F = 0\text{mA}$, $V_{OL}=0.8\text{V}$, $R_L=350\Omega$, $T_A=25^\circ\text{C}$ $V_{CM}=10\text{Vp-p}$ (Fig.14)
	EL2601	5,000	-	-		$I_F = 0\text{mA}$, $V_{OL}=0.8\text{V}$, $R_L=350\Omega$, $T_A=25^\circ\text{C}$ $V_{CM}=50\text{Vp-p}$ (Fig.14)
	EL2611	10,000	-	-		$I_F = 0\text{mA}$, $V_{OL}=0.8\text{V}$, $R_L=350\Omega$, $T_A=25^\circ\text{C}$ $V_{CM}=400\text{Vp-p}$ (Fig.14)
	EL2611	20,000	-	-		$I_F = 7.5\text{mA}$, $V_{OH}=2.0\text{V}$, $R_L=350\Omega$, $T_A=25^\circ\text{C}$ $V_{CM}=400\text{Vp-p}$ (Fig.15)

Typical Electro-Optical Characteristics Curves

Fig.1 Input Diode Forward Voltage vs. Forward Current

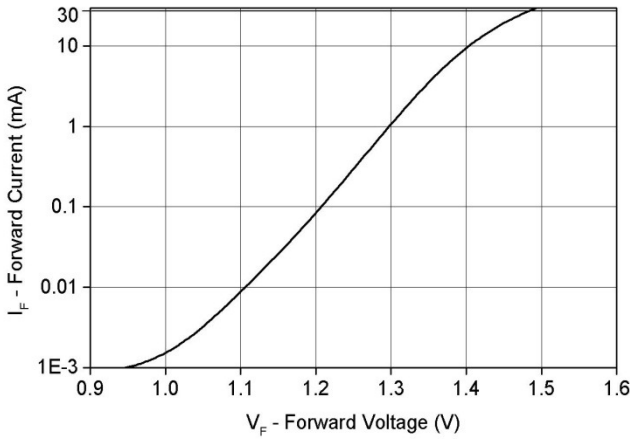

Fig.2 Low Level Output Voltage vs. Ambient Temperature

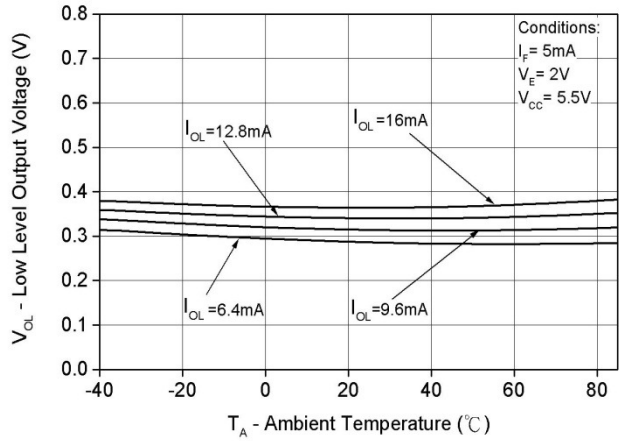

Fig.3 Low Level Output Current vs. Ambient Temperature

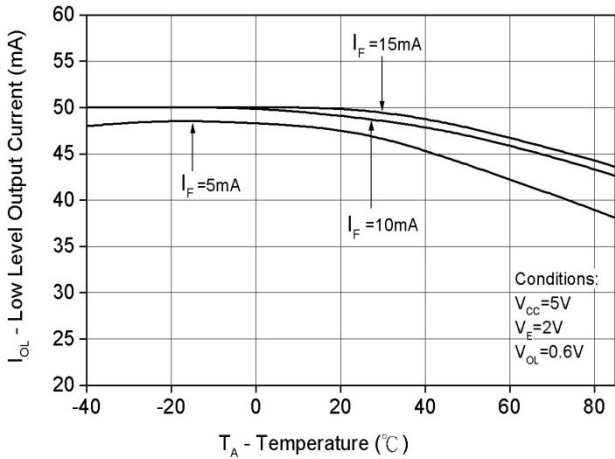

Fig.4 Input Threshold Current vs. Ambient Temperature

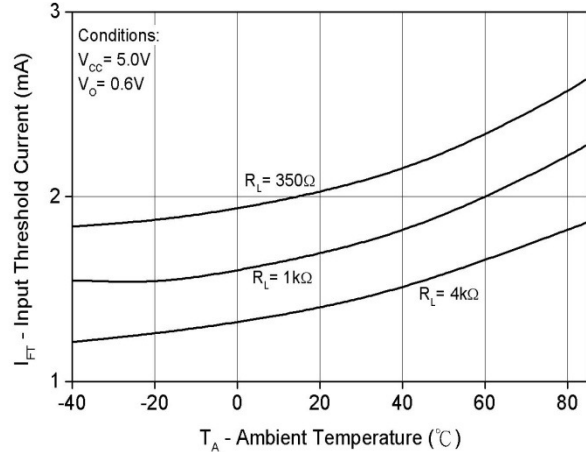

Fig.5 Output Voltage vs. Input Forward Current

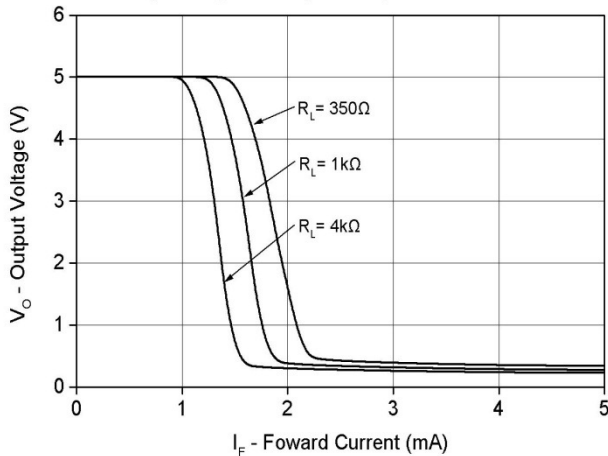

Fig.6 High Level Output Current vs. Temperature

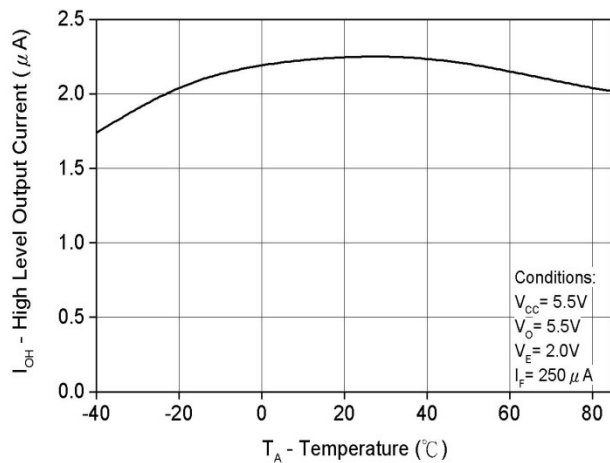

Fig.7 Switching Time vs. Forward Current

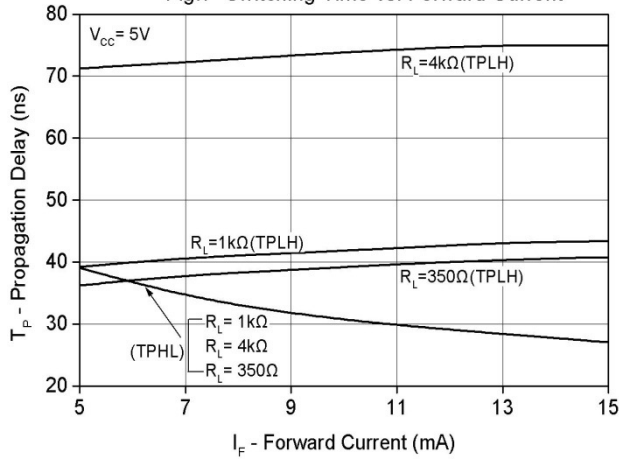

Fig.8 Switching Time vs. Temperature

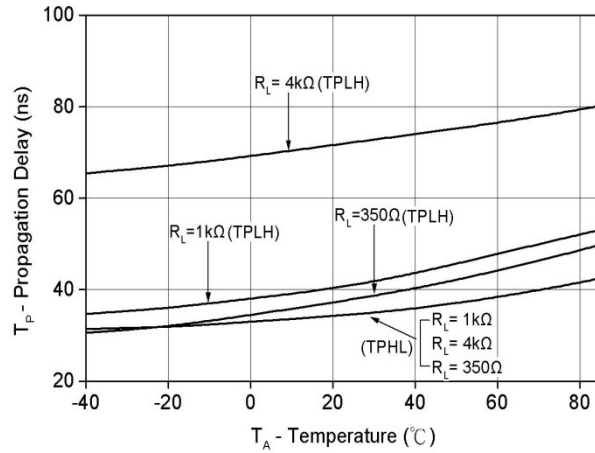

Fig.9 Pulse Width Distortion vs. Temperature

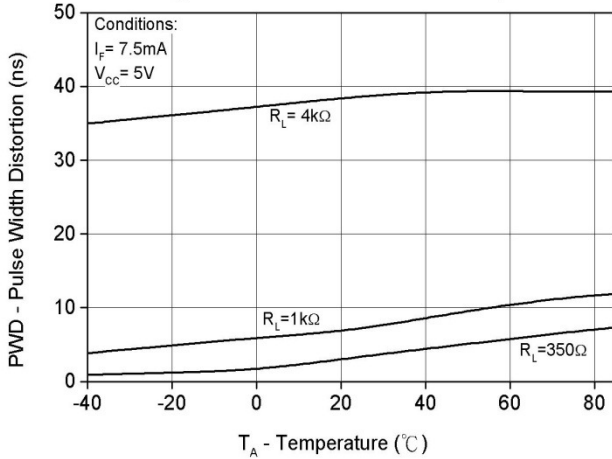

Fig.10 Rise and Fall Time vs. Temperature

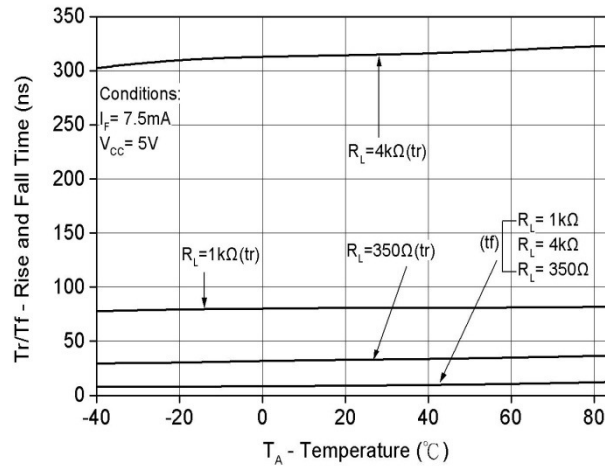

Fig.11 Enable Propagation Delay vs. Temperature

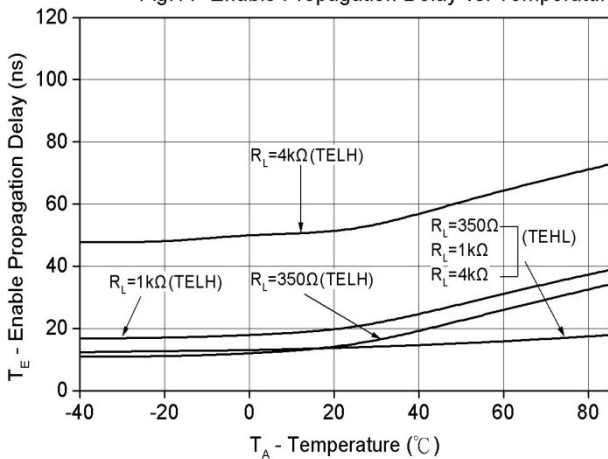

Fig. 12 Test circuit and waveforms for t_{PHL} , t_{PLH} , t_r , and t_f

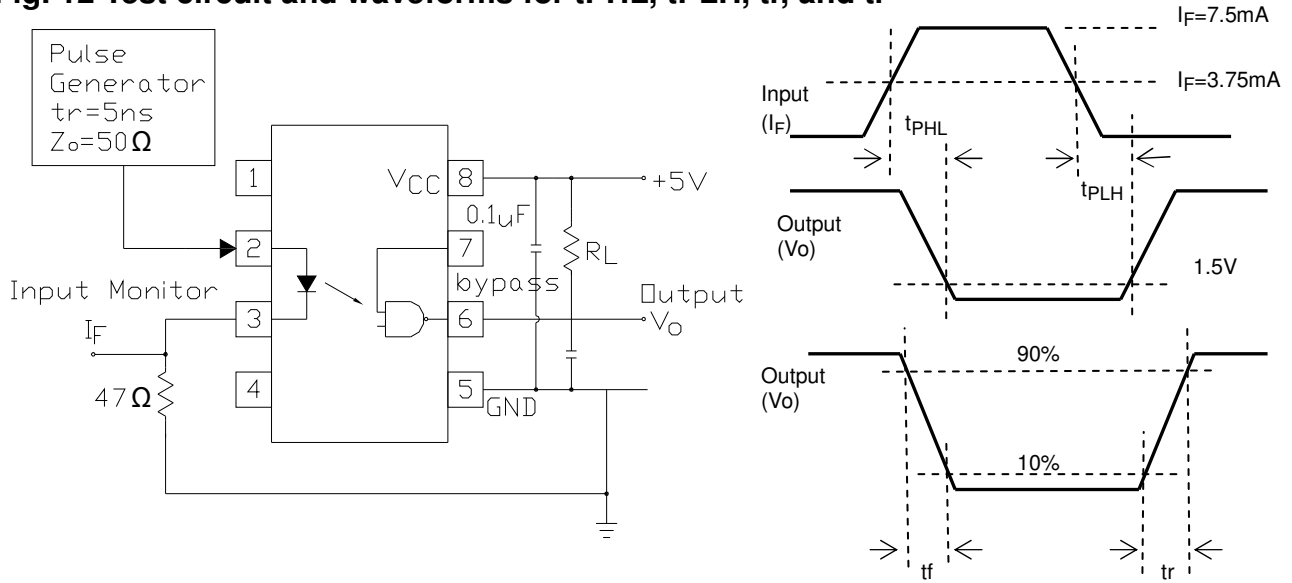

Fig. 13 Test circuit and waveform for t_{EHL} and t_{ELH}

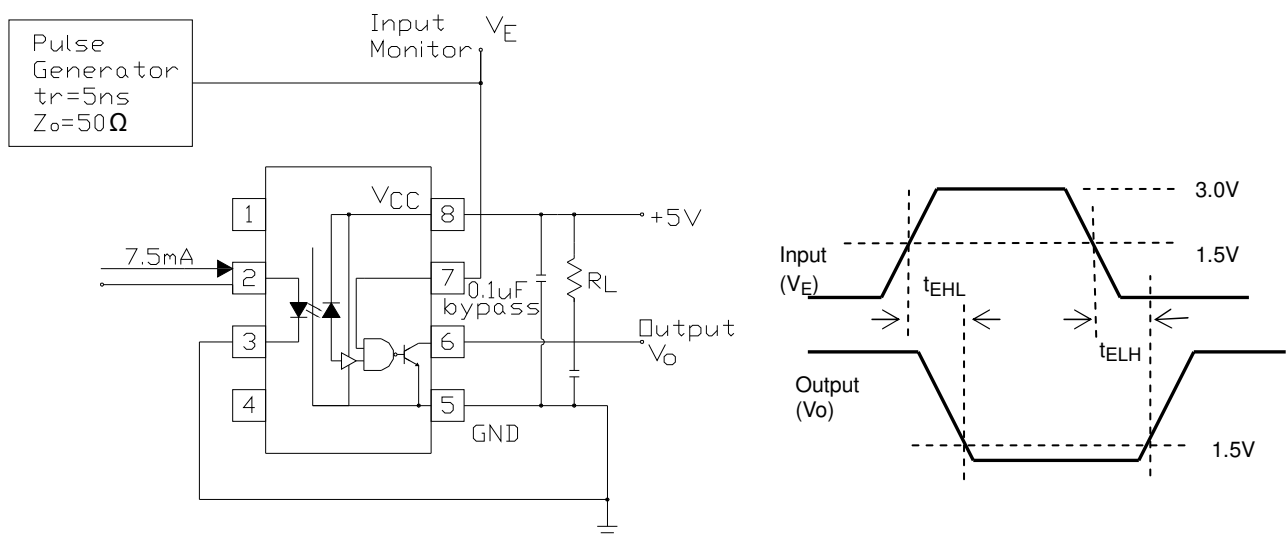

Fig. 14 Test circuit Common mode Transient Immunity

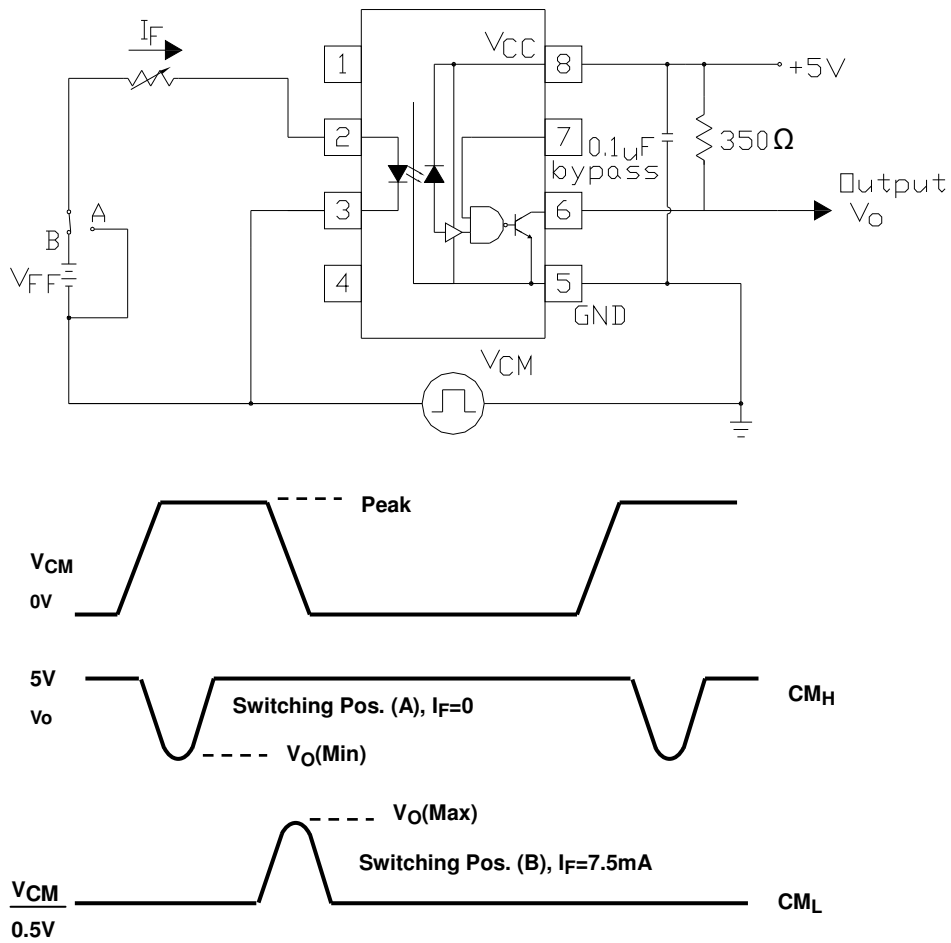
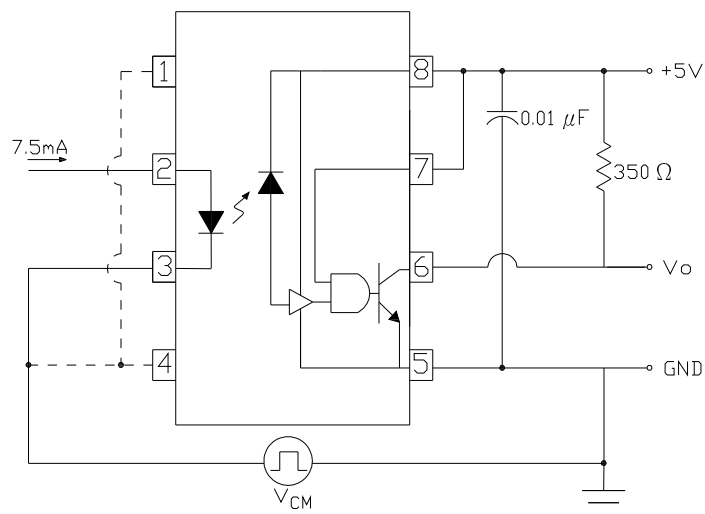

Fig. 15 Recommended drive circuit for EL2611 families for high-CMR



Note

- *3 The VCC supply must be bypassed by a 0.1µF capacitor or larger. This can be either a ceramic or solid tantalum capacitor with good high frequency characteristic and should be connected as close as possible to the package VCC and GND pins
- *4. Enable Input – No pull up resistor required as the device has an internal pull up resistor.
- *5. tPLH – Propagation delay is measured from the 3.75mA level on the HIGH to LOW transition of the input current pulse to the 1.5 V level on the LOW to HIGH transition of the output voltage pulse.
- *6. tPHL – Propagation delay is measured from the 3.75mA level on the LOW to HIGH transition of the input current pulse to the 1.5 V level on the HIGH to LOW transition of the output voltage pulse.
- *7. tr – Rise time is measured from the 90% to the 10% levels on the LOW to HIGH transition of the output pulse.
- *8. tf – Fall time is measured from the 10% to the 90% levels on the HIGH to LOW transition of the output pulse.
- *9. tELH – Enable input propagation delay is measured from the 1.5V level on the HIGH to LOW transition of the input voltage pulse to the 1.5V level on the LOW to HIGH transition of the output voltage pulse.
- *10. tEHL – Enable input propagation delay is measured from the 1.5V level on the LOW to HIGH transition of the input voltage pulse to the 1.5V level on the HIGH to LOW transition of the output voltage pulse.
- *11 CMH– The maximum tolerable rate of rise of the common mode voltage to ensure the output will remain in the HIGH state (i.e., VOUT > 2.0V).
- *12 CML– The maximum tolerable rate of rise of the common mode voltage to ensure the output will remain in the LOW output state (i.e., VOUT < 0.8V).

Order Information

Part Number

6N137Y(Z)-V

or

EL26XXY(Z)-V

Note

- X = (01 or 11) for EL26 part no.
- Y = Lead form option (S, S1, M or none)
- Z = Tape and reel option (TA, TB or none).
- V = VDE (optional)

Option	Description	Packing quantity
None	Standard DIP-8	45 units per tube
M	Wide lead bend (0.4 inch spacing)	45 units per tube
S (TA)	Surface mount lead form + TA tape & reel option	1000 units per reel
S (TB)	Surface mount lead form + TB tape & reel option	1000 units per reel
S1 (TA)	Surface mount lead form (low profile) + TA tape & reel option	1000 units per reel
S1 (TB)	Surface mount lead form (low profile) + TB tape & reel option	1000 units per reel

Package Dimension
(Dimensions in mm)

Standard DIP Type

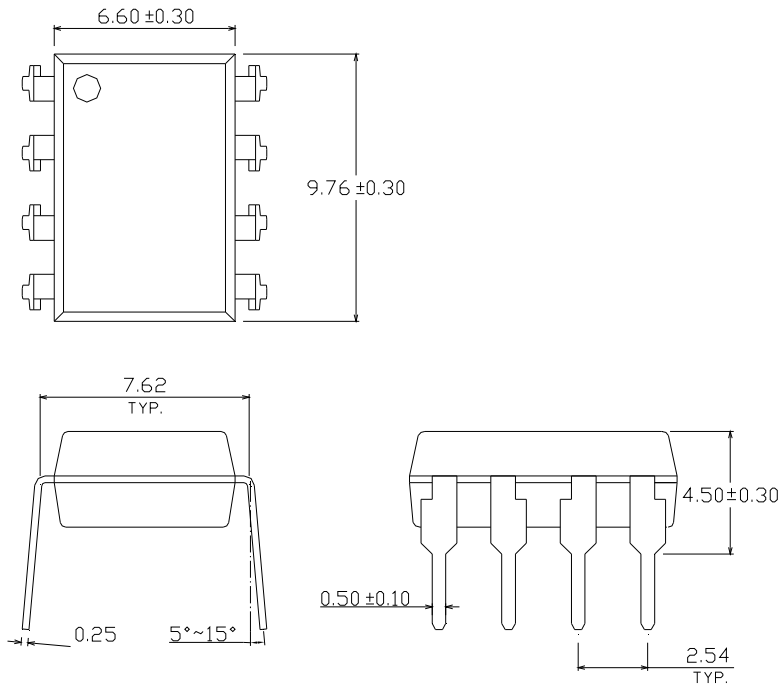

Option M Type

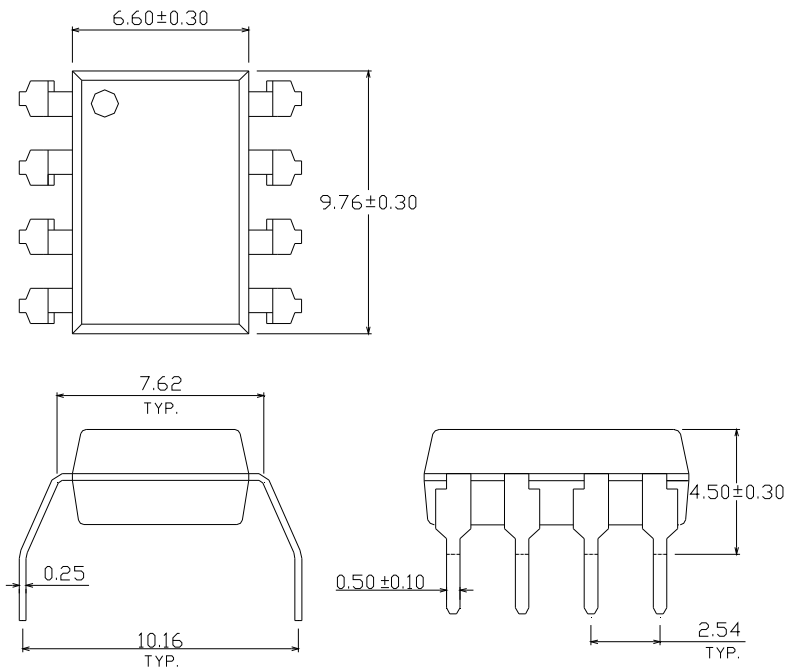

Option S Type

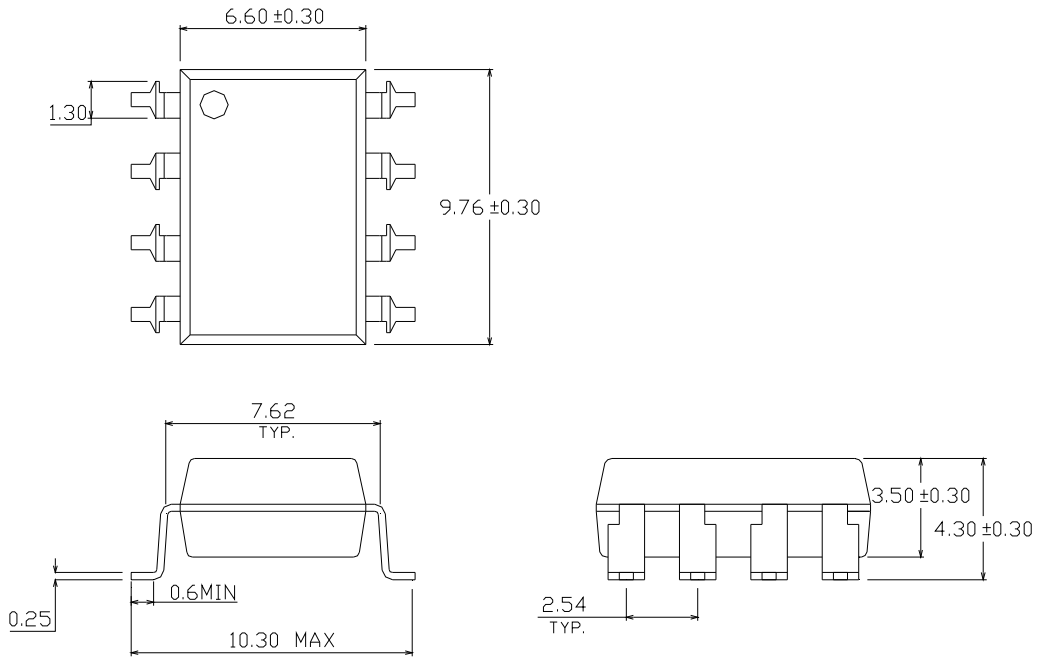

Option S1 Type

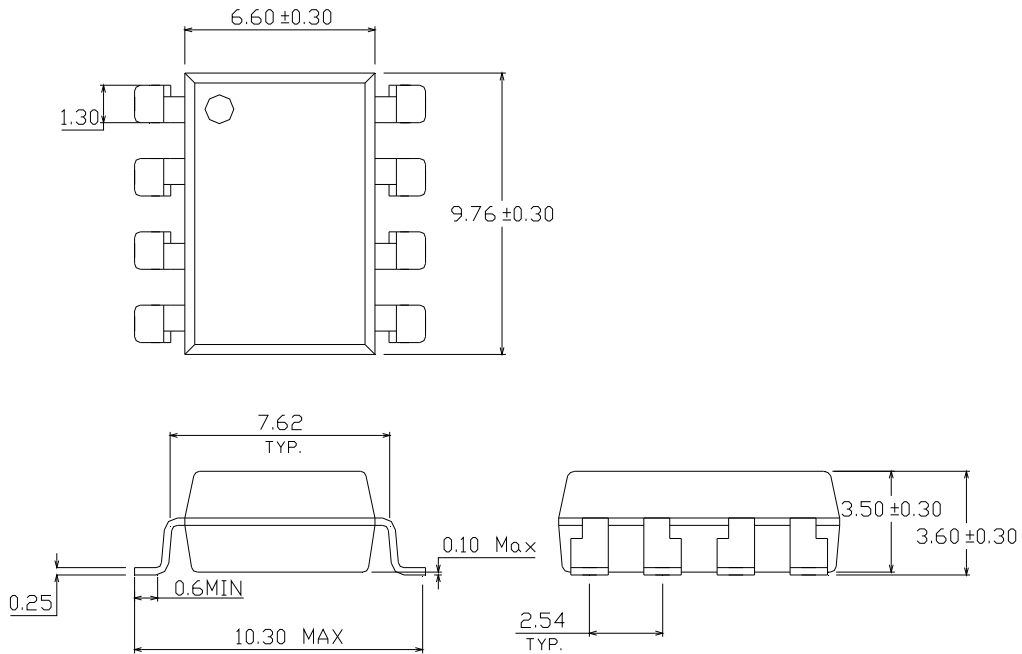

Recommended pad layout for surface mount leadform

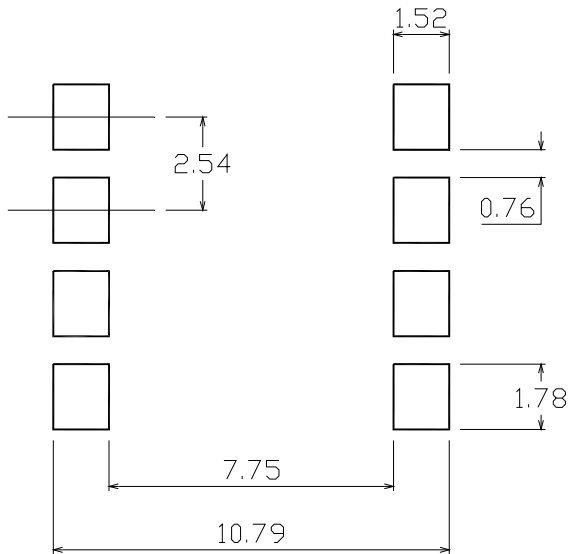

Device Marking

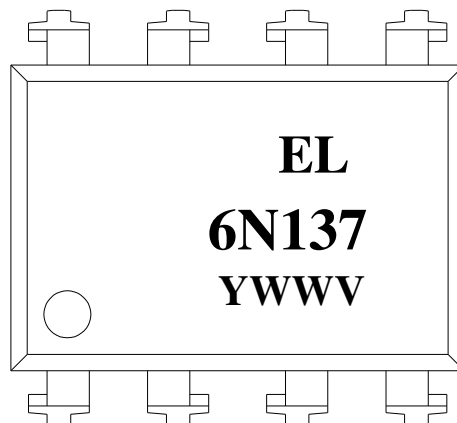

Notes

- EL denotes EVERLIGHT
- 6N137 denotes Device Number
- Y denotes 1 digit Year code
- WW denotes 2 digit Week code
- V denotes VDE (optional)

Tape & Reel Packing Specifications

Option TA

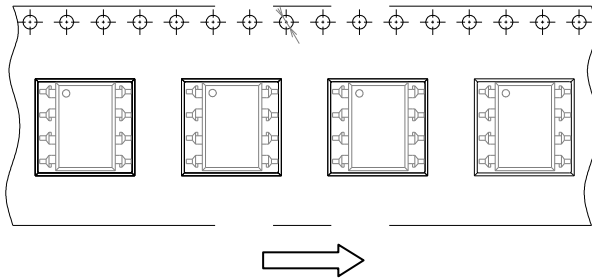

Direction of feed from reel

Option TB

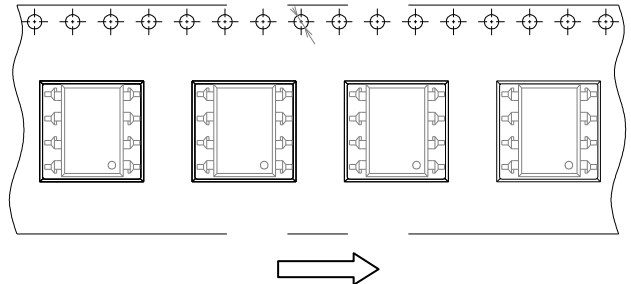

Direction of feed from reel

Tape dimension

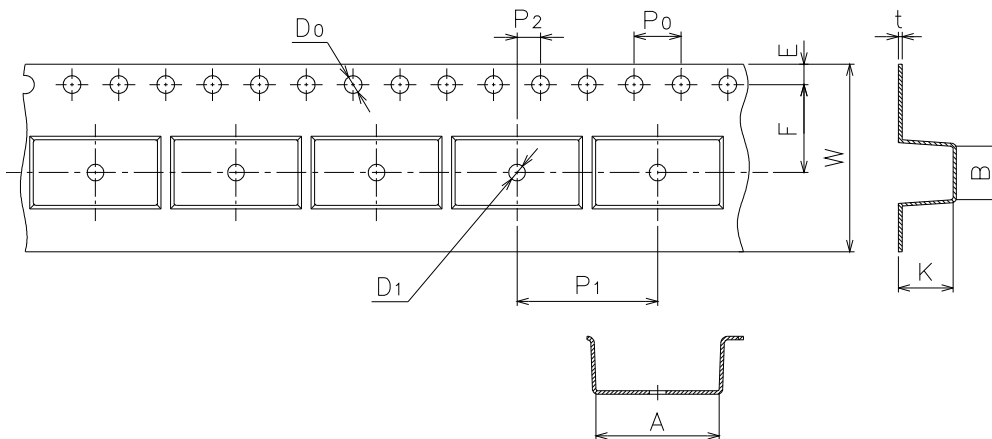

Dimension No.	A	B	D₀	D₁	E	F
Dimension(mm)	10.4±0.1	10.0±0.1	1.5+0.1/-0	1.5±0.25/-0	1.75±0.1	7.5±0.1
Dimension No.	P₀	P₁	P₂	t	W	K
Dimension(mm)	4.0±0.1	12.0±0.1	2.0±0.05	0.4±0.05	16.0±0.3/	4.5±0.1

Precautions for Use

1. Soldering Condition

1.1 (A) Maximum Body Case Temperature Profile for evaluation of Reflow Profile

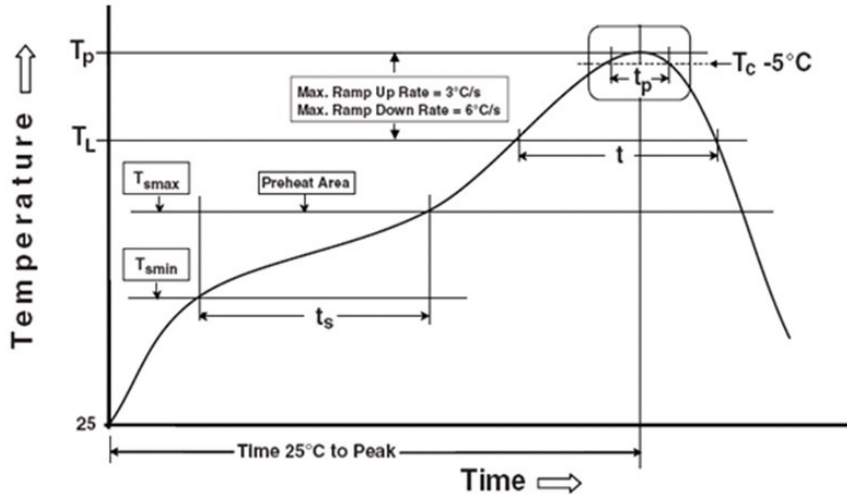

Note:

Reference: IPC/JEDEC J-STD-020D

Preheat

Temperature min (T_{smin})	150 °C
Temperature max (T_{smax})	200 °C
Time (T_{smin} to T_{smax}) (t_s)	60-120 seconds
Average ramp-up rate (T_{smax} to T_p)	3 °C/second max

Other

Liquidus Temperature (T_L)	217 °C
Time above Liquidus Temperature (t_L)	60-100 sec
Peak Temperature (T_p)	260 °C
Time within 5 °C of Actual Peak Temperature: $T_p - 5$ °C	30 s
Ramp- Down Rate from Peak Temperature	6 °C /second max.
Time 25 °C to peak temperature	8 minutes max.
Reflow times	3 times

DISCLAIMER

1. Above specification may be changed without notice. EVERLIGHT will reserve authority on material change for above specification.
2. When using this product, please observe the absolute maximum ratings and the instructions for using outlined in these specification sheets. EVERLIGHT assumes no responsibility for any damage resulting from use of the product which does not comply with the absolute maximum ratings and the instructions included in these specification sheets.
3. These specification sheets include materials protected under copyright of EVERLIGHT corporation. Please don't reproduce or cause anyone to reproduce them without EVERLIGHT's consent.

Looking for pricing, stock, or lifecycle information?

Click below to explore more details on WIN SOURCE:

- ⊖ [View EL2601S1\(TA\) on WIN SOURCE](#)
- ⊖ [Everlight Electronics Co Ltd Information](#)

Optimize Your Supply Chain with WIN SOURCE Solutions

- ✓ Global Sourcing Solution
- ✓ Obsolete Management
- ✓ Cost Control Management
- ✓ Shortage Management
- ✓ Alternative Solution
- ✓ Excess Inventory Management