



**THE DATASHEET OF
SIT6085EB**



Manufacturing Notes for SiTime MEMS-Based Silicon Timing Products

1 Introduction

These manufacturing notes apply to all of SiTime's MEMS-based Silicon Timing products in Quad, Flat No-Lead (QFN) package, SOT23-5 package, 2.0 x 1.2mm SMD, and WLCSP. The information provided in this document is meant to assist customers with manufacturing set-up and use of SiTime products designed into systems.

The materials used in the construction of SiTime's products comply with Green standards. They are compliant to RoHS and REACH163 requirements. Material composition reports are on file and can be made available on request. No hazardous materials defined by OSHA are contained in the products and MSDS reports are not required when using SiTime's products.

All SiTime products have been qualified to JEDEC JESD47 requirements as they apply to the type of product and packaging of the product. Reliability reports are available upon request from your sales representative.

2 Device Packaging

Detailed mechanical dimensions for the various body sizes are provided in the data sheets as Package Outline Drawings.

2.1 Package Marking Details - Standard Mark

The Standard Mark for all SiTime products is shown below. It contains an assembly location code and lot code to allow tracing the manufacturing origin. This marking is used on all samples, low volume, and mass production orders unless stipulated otherwise. The marking method is laser mark.

2.0x1.6 package marking diagram:

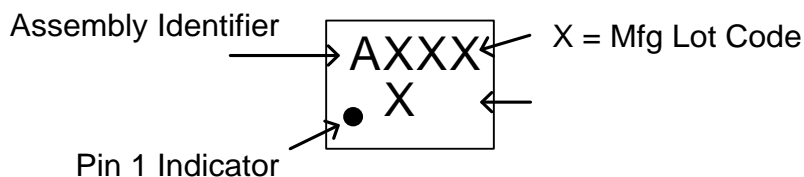

Other packages marking diagram:

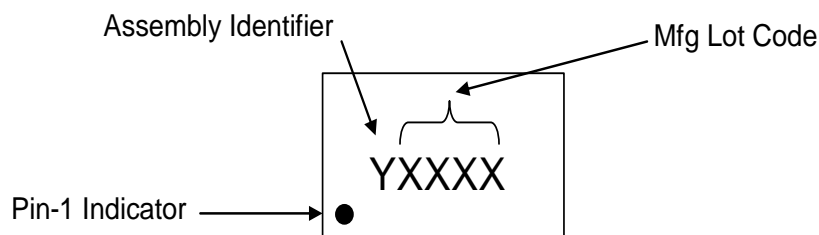

In the above diagrams, which show the “STANDARD MARK”:

“Y” denotes assembly identifier:

- A as a first letter to indicate Vendor A (Carsem)
- B as a first letter to indicate Vendor B (UTAC)
- C as a first letter to indicate Vendor C (ASE)

“XXXX” denotes 4 alpha-numeric characters of the manufacturing lot code without any dashes, periods, or symbols.

Top Marking Dimensions (otherwise indicated differently)

- All dimension are in mm
- Font type: LLGOTHIC_STD or EO135P or EO145
- Tolerance for:
 - o Dimension X, X1, Y and Y1: +/- 0.25mm
 - o Dimension Y2: +/- 0.1mm
 - o Char Pitch: +/- 0.1mm
 - o Char Height: +/- 0.1mm
 - o Pin 1 Dot Diameter: +/- 0.1mm
 - o All other tolerances: +/- 0.20 mm

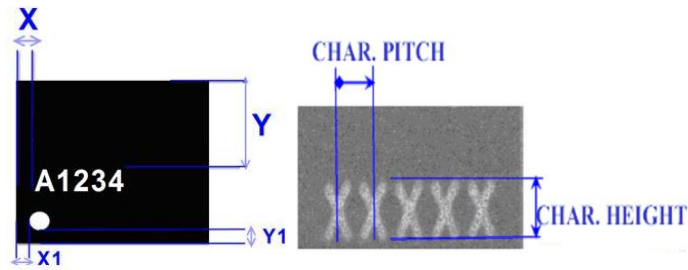

Figure 1. Standard Marking Dimensions For 2.5x2.0, 3.2x2.5, 5.0x3.2, 7.0x5.0mm, and SOT23 Packages

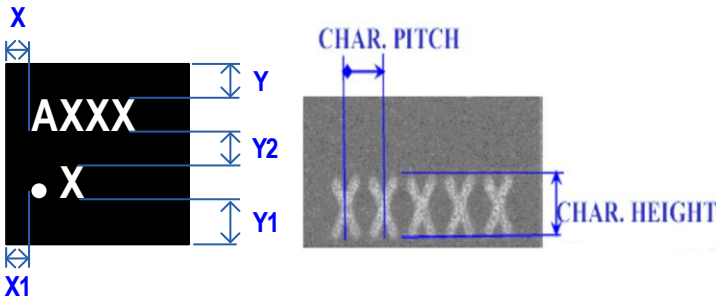

Figure 2. Standard Marking Dimensions for 2.0x1.6mm Package

Table 1. Marking Dimensions for Package Type

Package	X	X1	Y	Y1	Y2	Char Height	Char Pitch	Pin 1 Dot diameter
2.5 x 2.0	0.30	0.30	0.85	0.25	N/A	0.45	0.35	0.25
SOT23	0.55	0.30	0.81	0.25	N/A	0.40	0.35	0.16
2.7 x 2.4	0.30	0.30	0.85	0.25	N/A	0.45	0.35	0.25
3.5 x 3.0	0.30	0.20	1.10	0.35	N/A	0.45	0.45	0.25
3.2 x 2.5	0.30	0.20	1.10	0.35	N/A	0.45	0.45	0.25
5.0 x 3.2	0.35	0.35	1.50	0.5	N/A	0.45	0.50	0.25
7.0 x 5.0	1.00	0.70	2.70	0.7	N/A	0.45	0.55	0.35
2.0 x 1.6	0.33	0.33	0.28	0.28	0.15	0.40	0.35	0.20

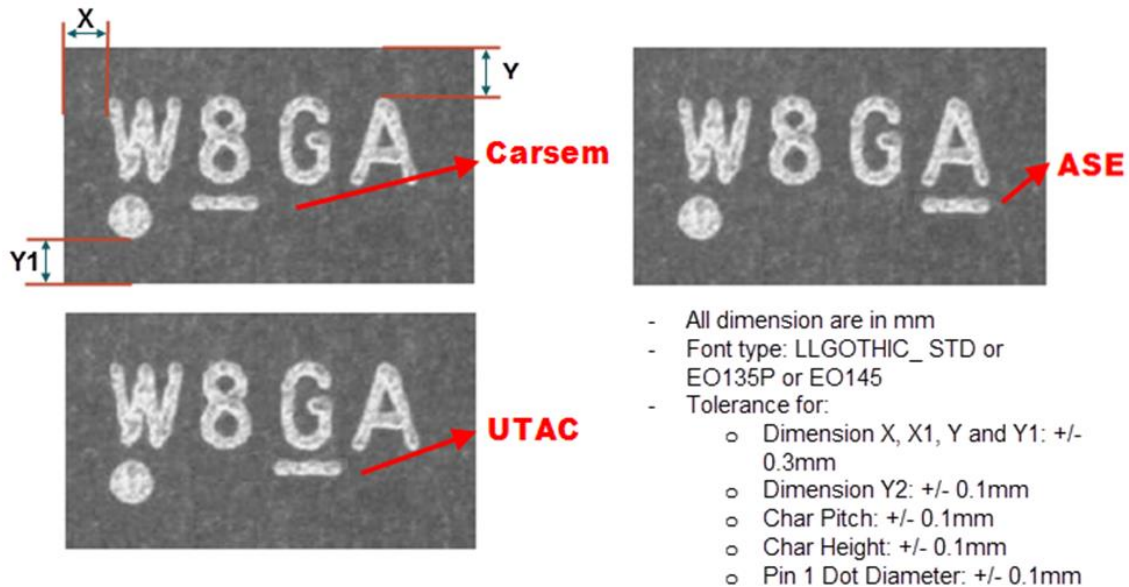
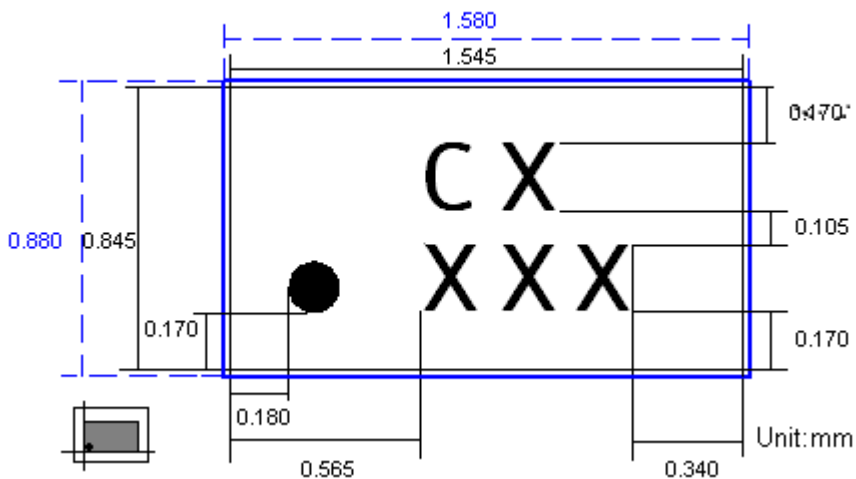

Figure 3. Standard Marking Dimensions for 2.0x1.2mm Package

Table 2. Marking Dimensions for SMD Package Type (2.0 mm X 1.2 mm)

Package	Char Height	Underline Width	Char Pitch	Pin 1 Diameter	X	Y	Y1
2.0 x 1.2	0.38	0.3	0.35	0.14	0.33	0.28	0.28



- **Font size tolerance:** (+/- 0.05mm)
- **Marking shift tolerance:** (+/- 0.15mm)

Figure 4. Standard Marking Dimensions for WLCSP Package

Table 3. Marking Dimensions for WLCSP Package

	Description	Position	Font Type	Height	Width	Space	Max Marking Width	Max chars
				X ↓	X ↔	X ↔ X	X X X X X ←-----→	
Pin 1 Dot	Dot	NA	NA	0.15 mm	0.15 mm	NA	NA	NA
Line 1	CX	Left	S_X.FNT	0.20 mm	0.18 mm	0.05 mm	0.41 mm	2
Line 2	XXX	Left	S_X.FNT	0.20 mm	0.18 mm	0.05 mm	0.64 mm	3

3 Product Packing

3.1 Tape & Reel

Carrier tape basic dimensions are based on EIA481. The pocket is designed to hold the part for shipping and loading onto SMT manufacturing equipment, while protecting the body and the solder terminals from damaging stresses. The individual pocket design can vary from vendor to vendor, but width and pitch will be consistent.

Carrier tape is wound or placed onto a 7" or 13" shipping reel depending on the quantity of parts on the reel and the package body size

The center hub design is large enough to ensure the radius formed by the carrier tape around it does not put unnecessary stress on the parts.

Prior to shipping, parts are placed into the pockets of the carrier tape. A cover tape is sealed over the top of the entire length of the carrier tape. The reel is sealed in a protective bag with a dry N2 backfill.

The reel is made with high impact polystyrene and is anti-static material. It is possible that color of the reels may be different in two different shipments depending on drop shipment location. However, the specifications of the reel are identical. The carrier tape is made with polystyrene with carbon impregnation and is static dissipative material. The cover tape is made with polystyrene antistatic material.

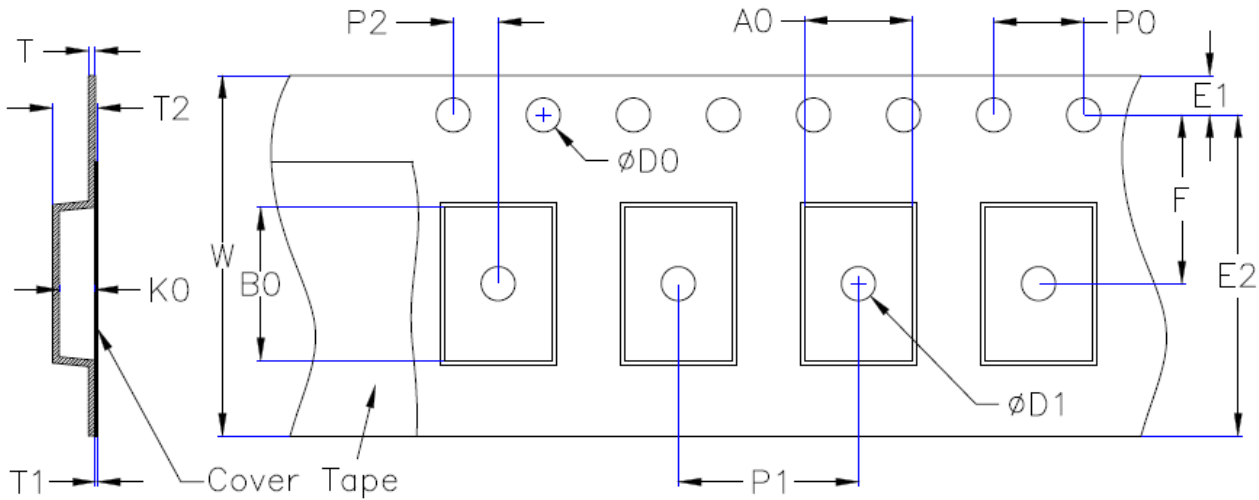

Package Outline Drawing	Package Size	Tape Size	D0	D1 Min.	E1	E2 Min.	F	P0	P1	P2	T	T1 Max	T2 Max	W Max.	A0	B0	K0
POD-1	2.5 x 2.0 x 0.75	12	1.5 +0.1/-0.0	1.5	1.75 ±0.1	10.25	5.5 ±0.05	4.0 ±0.1	4.0 ±0.1	2.0 ±0.05	0.6	0.1	1.65	12.3	2.3 ±0.10	2.8 ±0.10	1.10 ±0.10
POD-1	2.5 x 2.0 x 0.75	8	1.55 ±0.05	1.0	1.75 ±0.1	5.85	3.5 ±0.05	4.0 ±0.1	4.0 ±0.1	2.0 ±0.05	0.3 ±0.05	0.1	1.65	8.3	2.25 ±0.05	2.8 ±0.05	1.10 ±0.10
POD-23	2.7 x 2.4 x 0.75	12	1.55 ±0.05	1.0	1.75 ±0.1	9.85	5.5 ±0.05	4.0 ±0.1	4.0 ±0.1	2.0 ±0.05	0.3 ±0.05	0.1	1.55	12.3	2.65 ±0.10	2.95 ±0.10	1.00 ±0.10
POD-23	2.7 x 2.4 x 0.75	8	1.55 ±0.05	1.0	1.75 ±0.1	5.85	3.5 ±0.05	4.0 ±0.1	4.0 ±0.1	2.0 ±0.05	0.3 ±0.05	0.1	1.55	8.3	2.65 ±0.10	2.95 ±0.10	1.00 ±0.10
POD-2	3.2 x 2.5 x 0.75	12	1.5 +0.1/-0.0	1.5	1.75 ±0.1	10.25	5.5 ±0.05	4.0 ±0.1	4.0 ±0.1	2.0 ±0.05	0.6	0.1	1.65	12.3	2.8 ±0.10	3.5 ±0.10	1.10 ±0.10
POD-2	3.2 x 2.5 x 0.75	8	1.5 +0.1/-0.0	1.0	1.75 ±0.1	5.95	3.5 ±0.05	4.0 ±0.1	4.0 ±0.1	2.0 ±0.05	0.2 ±0.05	0.1	1.65	8.2	2.7 ±0.10	3.4 ±0.10	1.15 ±0.10
POD-3	5.0 x 3.2 x 0.75	12	1.5 +0.1/-0.0	1.5	1.75 ±0.1	10.25	5.5 ±0.05	4.0 ±0.1	8.0 ±0.1	2.0 ±0.05	0.6	0.1	1.65	12.3	3.5 ±0.10	5.3 ±0.10	1.10 ±0.10
POD-4	7.0 x 5.0 x 0.90	16	1.5 +0.1/-0.0	1.5	1.75 ±0.1	14.25	7.5 ±0.1	4.0 ±0.1	8.0 ±0.1	2.0 ±0.1	0.6	0.1	1.80	16.3	5.4 ±0.10	7.4 ±0.10	1.3 ±0.1
POD-9	3.5 x 3.0 x 0.30	12	1.5 +0.1/-0.0	1.5	1.75 ±0.1	10.25	5.5 ±0.05	4.0 ±0.1	8.0 ±0.1	2.0 ±0.05	0.6	0.1	1.65	12.3	3.3 ±0.10	3.8 ±0.10	0.65 ±0.10
POD-26	2.0 x 1.6 x 0.75	8	1.55 ±0.05	0.9	1.75 ±0.1	6.05	3.5 ±0.05	4.0 ±0.1	4.0 ±0.1	2.0 ±0.05	0.3 ±0.05	0.1	1.55	8.3	1.9 ±0.05	2.3 ±0.05	1.00 ±0.10
POD-29	2.0 x 1.2 x 0.60	8	1.55 ±0.05	1.0	1.75 ±0.1	6.05	3.5 ±0.05	4.0 ±0.1	4.0 ±0.1	2.0 ±0.05	0.25 ±0.05	0.1	1.55	8.3	1.9 ±0.05	2.3 ±0.05	1.00 ±0.10
POD-32	1.5 x 0.8 x 0.6	8	1.55 ±0.05	0.18	1.75 ±0.1	6.05	3.5 ±0.05	4.0 ±0.1	4.0 ±0.1	2.0 ±0.05	0.2 ±0.02	0.1	1.55	8.3	0.96 ±0.03	1.66 ±0.03	0.63 ±0.03
SOT-23	2.8 x 1.6 x 1.45	8	1.55 ±0.05	1.0	1.75 ±0.1	6.05	3.5 ±0.05	4.0 ±0.1	4.0 ±0.1	2.0 ±0.05	0.25 ±0.02	0.1	1.62	8.3	3.23 ±0.10	3.17 ±0.10	1.37 ±0.10

SiTime Confidential – Do Not Distribute

Notes:

- 1) All tapes are compliant with EIA 481A
- 2) The tape with or without components shall pass around 30mm without damage
- 3) All measurements are in mm

FILE NAME TNR-1.dwg	SiTime Carrier Tape	
CONTRACT NO -	Tape & Reel	
DRAWN 4/15/13 prestong	SiTime Carrier Tape	
CHECK 6/24/15 nivia	REV A05	
APPR. 6/24/15 pavang	SHEET 1 of 2	
ISSUED 6/24/15 ganesh	DWG NO TNR-1	
SiTime 990 Almanor Ave. Sunnyvale, CA 94085	SIZE A	FSCM NO -
	SCALE NTS	

Figure 5. Carrier Tape Dimensions

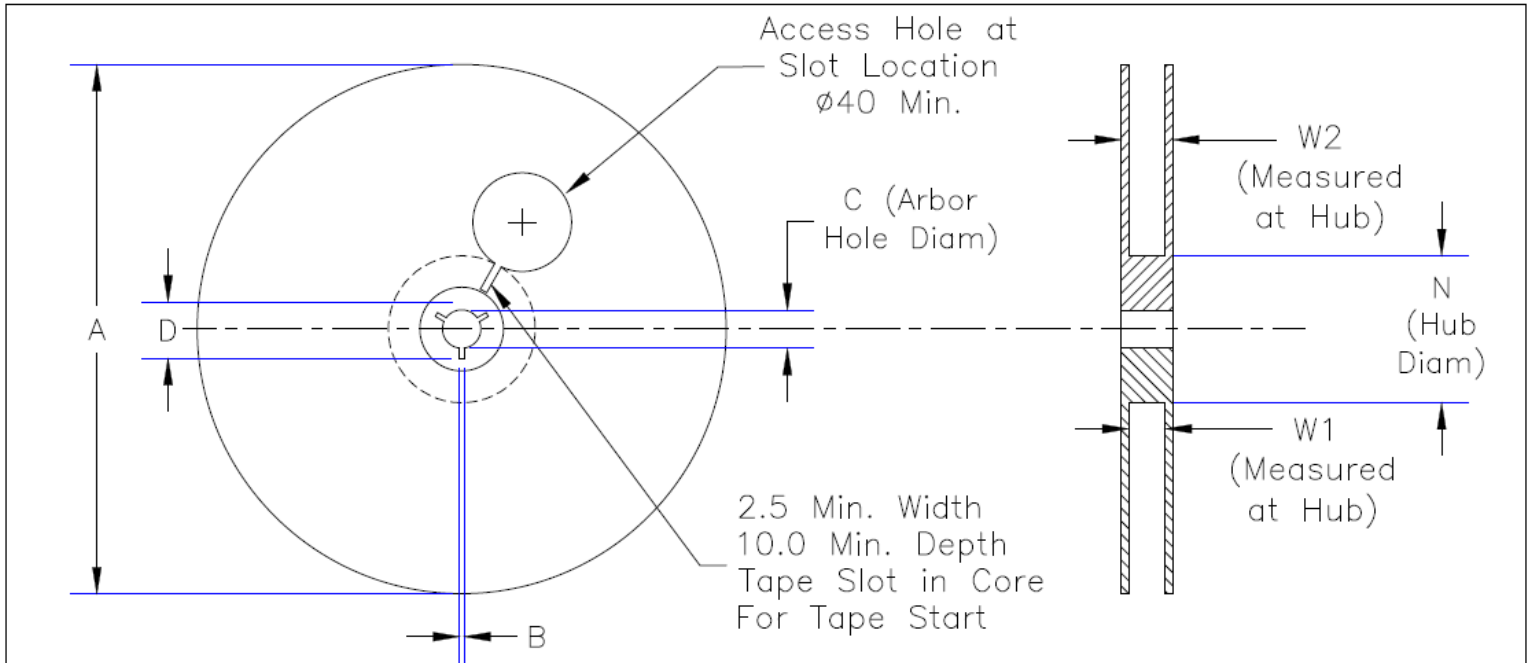

Tap e Size	A Max.	B Min.	C	D Min.	N	W1	W2 Max.
8	180	1.5	13.0 +0.6/-0.2	20.2	60 +0.5/-0.5	8.4 +1.5/-0	14.4
8	330	1.5	13.0 +0.2/-0.2	20.2	100 +0.5/-0.5	8.4 +1.5/-0	14.4
12	330	1.5	13.0 +0.2/-0.2	20.2	100 +0.5/-0.5	12.4 +2.0/-0	18.4
12	180	1.5	13.0 +0.2/-0.2	20.2	60 +0.5/-0.5	12.4 +2.0/-0	18.4
16	330	1.5	13.0 +0.2/-0.2	20.2	100 +0.5/-0.5	16.4 +2.0/-0	22.4
16	180	1.5	13.0 +0.2/-0.2	20.2	60 +0.5/-0.5	16.4 +2.0/-0	22.4

Note: All measurements are in mm

SiTime Confidential – Do Not Distribute

FILE NAME TNR-1.dwg		SiTime Carrier Tape	
CONTRACT NO -		Tape & Reel	
DRAWN 4/15/13 prestong		SiTime Carrier Tape	
CHECK 6/24/15 nivia		SIZE A	
APPR. 6/24/15 pavang		FSCM NO -	
ISSUED 6/24/15 ganesh		DWG NO TNR-1	
		REV A05	
990 Almanor Ave. Sunnyvale, CA 94085		SCALE NTS	
		SHEET 2 of 2	

Figure 6. Reel Dimensions

Device orientation in the carrier tape is shown in the diagram below for all QFN and WLCSP packages (Figure 7) and SOT23-5 (Figure 8).

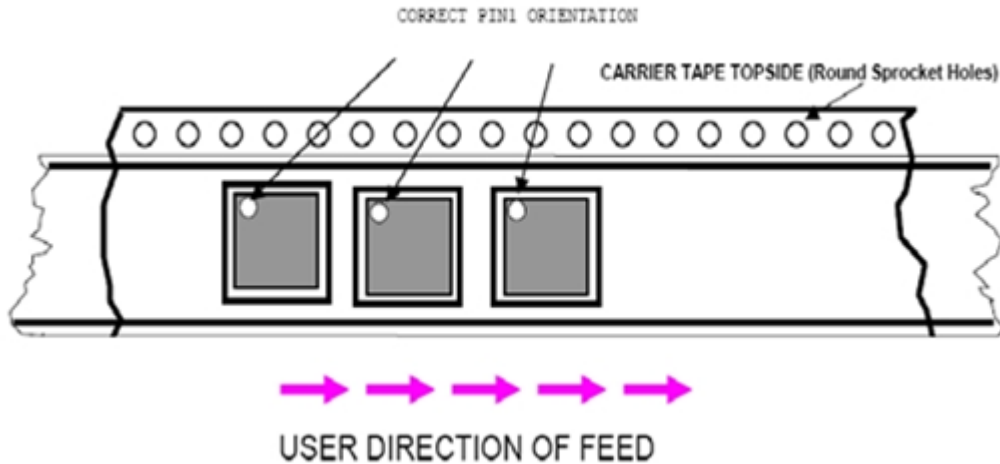

Figure 7. Standard Tape and Reel Pin 1 orientation (all except for SOT-23)

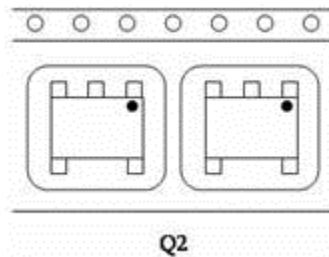

Figure 8. SOT23 Tape and Reel Pin 1 orientation

Table 4 below provides the ordering details for tape and reel quantity, reel size, and top mark options. The “Suffix” character is the last character in the part number string as shown in the example below. Deviation from this table will be indicated via a custom part number (CS).

SIT8002AI-23-33E-30.00000Y

↑
Suffix
Character

Table 4. Marking and Tape & Reel Option Selections with Part Number Coding

Suffix	Packaging Method	Package Size (mm)	Reel Size (inches)	Qty per Reel	Top Mark
M	Bulk	All	N/A	Shipped in canister or ESD bag or tube – any qty	2 Lines Frequency Mark
V	16mm Tape & Reel	7.0 x 5.0	13	3000	2 Lines Frequency Mark
	12mm Tape & Reel	5.0 x 3.2	13	3000	
	12mm Tape & Reel	3.2 x 2.5	7	3000	
	12mm Tape & Reel	2.7 x 2.4	7	3000	
	12mm Tape & Reel	2.5 x 2.0	7	3000	
Z	16mm Tape & Reel	7.0 x 5.0	7	1000	2 Lines Frequency Mark
	12mm Tape & Reel	5.0 x 3.2	7	1000	
	12mm Tape & Reel	3.2 x 2.5	7	1000	
	12mm Tape & Reel	2.7 x 2.4	7	1000	
	12mm Tape & Reel	2.5 x 2.0	7	1000	
W	16mm Tape & Reel	7.0 x 5.0	7	250	2 Lines Frequency Mark
	12mm Tape & Reel	5.0 x 3.2	7	250	
	12mm Tape & Reel	3.2 x 2.5	7	250	
	12mm Tape & Reel	2.7 x 2.4	7	250	
	12mm Tape & Reel	2.5 x 2.0	7	250	
H	8mm Tape & Reel	3.2 x 2.5	7	3000	2 Lines Frequency Mark
	8mm Tape & Reel	2.7 x 2.4	7	3000	
	8mm Tape & Reel	2.5 x 2.0	7	3000	
	8mm Tape & Reel	2.0 x 1.6	7	3000	
J	8mm Tape & Reel	3.2 x 2.5	7	1000	2 Lines Frequency Mark
	8mm Tape & Reel	2.7 x 2.4	7	1000	
	8mm Tape & Reel	2.5 x 2.0	7	1000	
	8mm Tape & Reel	2.0 x 1.6	7	1000	
K	8mm Tape & Reel	3.2 x 2.5	7	250	2 Lines Frequency Mark
	8mm Tape & Reel	2.7 x 2.4	7	250	
	8mm Tape & Reel	2.5 x 2.0	7	250	
	8mm Tape & Reel	2.0 x 1.6	7	250	
T	16mm Tape & Reel	7.0 x 5.0	13	3000	1 Line Standard Mark
	12mm Tape & Reel	5.0 x 3.2	13	3000	
	12mm Tape & Reel	3.2 x 2.5	7	3000	
	12mm Tape & Reel	2.7 x 2.4	7	3000	
	12mm Tape & Reel	2.5 x 2.0	7	3000	
Y	16mm Tape & Reel	7.0 x 5.0	7	1000	1 Line Standard Mark
	12mm Tape & Reel	5.0 x 3.2	7	1000	
	12mm Tape & Reel	3.2 x 2.5	7	1000	
	12mm Tape & Reel	2.7 x 2.4	7	1000	
	12mm Tape & Reel	2.5 x 2.0	7	1000	
X	16mm Tape & Reel	7.0 x 5.0	7	250	1 Line Standard Mark
	12mm Tape & Reel	5.0 x 3.2	7	250	
	12mm Tape & Reel	3.2 x 2.5	7	250	
	12mm Tape & Reel	2.7 x 2.4	7	250	
	12mm Tape & Reel	2.5 x 2.0	7	250	

Table 4 (cont.)

Suffix	Packaging Method	Package Size (mm)	Reel Size (inches)	Qty per Reel	Top Mark
D	8mm Tape & Reel	3.2 x 2.5	7	3000	1 Line Standard Mark
	8mm Tape & Reel	2.7 x 2.4	7	3000	
	8mm Tape & Reel	2.5 x 2.0	7	3000	
	8mm Tape & Reel	2.0 x 1.6	7	3000	
	8mm Tape & Reel	2.0 x 1.2	7	3000	
	8mm Tape & Reel	WLCSP	7	3000	Two Line Standard Mark
E	8mm Tape & Reel	3.2 x 2.5	7	1000	1 Line Standard Mark
	8mm Tape & Reel	2.7 x 2.4	7	1000	
	8mm Tape & Reel	2.5 x 2.0	7	1000	
	8mm Tape & Reel	2.0 x 1.2	7	1000	
	8mm Tape & Reel	2.0 x 1.6	7	1000	
	8mm Tape & Reel	WLCSP	7	1000	Two Line Standard Mark
G	8mm Tape & Reel	3.2 x 2.5	7	250	1 Line Standard Mark
	8mm Tape & Reel	2.7 x 2.4	7	250	
	8mm Tape & Reel	2.5 x 2.0	7	250	
	8mm Tape & Reel	2.0 x 1.6	7	250	
	8mm Tape & Reel	2.0 x 1.2	13	10000	1 Line Standard Mark
S	8mm Tape & Reel	WLCSP	13	10000	Two Line Standard Mark
Blank Devices	Bulk	All	N/A	Shipped in canister or ESD bag or tube – any qty	1 Line Standard Mark

Tape leader and trailer are per EIA-481-B as shown below:

Table 5. Leader and Trailer Lengths

All Reels	Minimum Length
Leader	400 mm
Trailer	160 mm

Peel Strength

The force required to peel off the cover tape from the carrier tape will fall within the range of 0.1 Newton to 1.3 Newton (10 grams to 130 grams) at a peeling speed to 300 mm per minute. This complies with the EIA standard.

4 Storage and Handling

It is recommended that the sealed tape be stored in conditions where the environment does not exceed:

- Temperature: 40°C maximum
- Relative humidity: 90% maximum
- No direct exposure to sunlight

5 ESD

SiTime's products are semiconductor based and as such have sensitivity to Electro-Static Discharge. Care must be taken to insure careful handling to avoid damaging the components. Reference to JEDEC document JESD625, Requirements for Handling Electrostatic-Discharge-Sensitive Devices. This standard establishes the minimum requirements for Electrostatic Discharge (ESD) control methods and materials used to protect electronic devices that are susceptible to damage or degradation from electrostatic discharge (ESD). The passage of a static charge through an electrostatic-discharge-sensitive (ESDS) device can result in catastrophic failure or performance degradation of the part. Device sensitivity to ESD is determined by test methods such as EIA/JESD22-A114.

6 Moisture Sensitivity Level

All SiTime's products have been qualified to Moisture Sensitivity Level 1 for Pb-Free devices per JEDEC J-STD-020 and are deemed to not be moisture sensitive. This means partially consumed reels may be stored indefinitely without re-sealing the protective storage bags in which the reels are shipped in. It also means unused reels with a damaged bag seal may be used without baking. Because the parts meet moisture sensitivity level 1, the protective storage bags in which the reels are shipped do not require desiccant or HIC cards and are not required to maintain a tight vacuum seal or dry nitrogen purge.

7 PCB Assembly Guidelines

7.1 Solder Reflow Profile

The solder reflow profile shown in Figure 9 is IPC/JEDEC J-STD-020 compliant and applies to all SiTime packages; QFN, SOT23-5, 2.0x1.2 SMD, and WLCSP. Maximum reflow temperature is 260°C. An optimized reflow profile depends on several factors such as the solder paste, board density, and type of reflow equipment used. Additional reflow information can be obtained from solder paste vendor data sheets. It is recommended that any reflow profile be characterized with a fully populated production PCB and thermocouple placed on or closest to the SiTime component during profile. Thermocouples are generally used to record temperatures across the surface and any sensitive components on the PCB. Ensure that a thermocouple is placed in contact with the top surface of any moisture sensitive component to ensure maximum temperature is not exceeded.

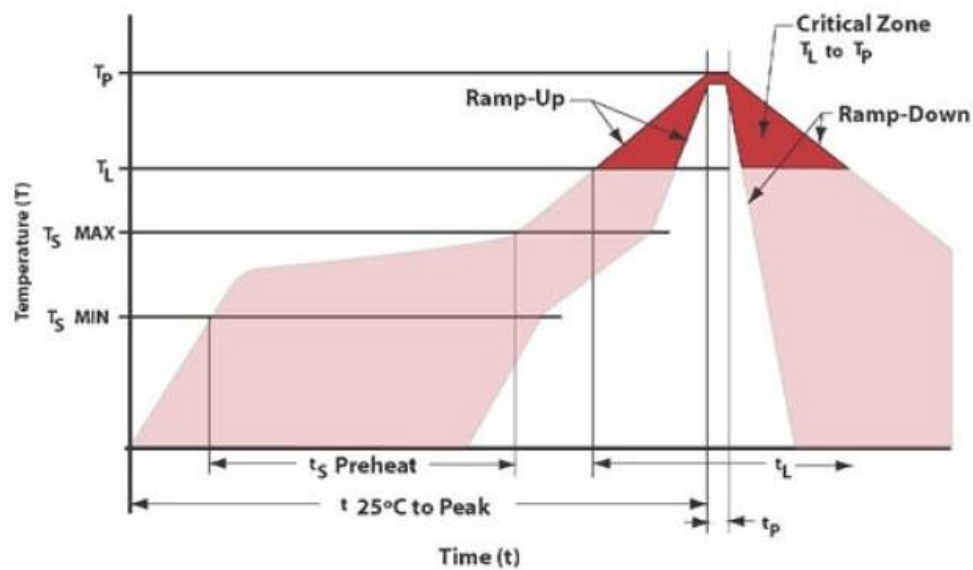

Figure 9. Convection Reflow Soldering Profile, per IPC/JEDEC J-STD-020

Table 6. High Temperature Infrared/Convection Reflow Conditions IPC/JEDEC J-STD-020

IPC/JEDEC Standard	IPC/JEDEC J-STD-020
Moisture Sensitivity Level	Level 1
TS MAX to TL (Ramp-up Rate)	3°C/second Maximum
Preheat	
- Temperature Minimum (TS MIN)	150°C
- Temperature Typical (TS TYP)	175°C
- Temperature Maximum (TS MAX)	200°C
- Time (tS)	60 - 180 Seconds
Ramp-up Rate (TL to TP)	3°C/second Maximum
Time Maintained Above:	
- Temperature (TL)	217°C
- Time (TL)	60 - 150 Seconds
Peak Temperature (TP)	260°C Maximum
Target Peak Temperature (TP Target)	255°C
Time within 5°C of actual peak (tP)	20 - 40 seconds
Max. Number of Reflow Cycles	3
Ramp-down Rate	6°C/second Maximum
Time 25°C to Peak Temperature (t)	8 minutes Maximum

Note: Temperatures shown are applied to body of device.

Table 7. Manual Soldering Conditions

Manual Soldering (Iron)	
350°C Maximum for 3 seconds	Caution: Small package body parts heat up very quickly and can be damaged

7.2 PCB Cleaning After Assembly

Cleaning PCB assemblies after reflow is a common process requirement to remove residual flux and loose solder. No-Clean and water soluble fluxes are left behind and require removal to meet assembly inspection standards. The package materials of the SiTime products are not susceptible to water or other common solvents (alcohol and acetone) used for assembly cleaning. SiTime recommends not using cleaning baths operating at ultrasonic frequencies. Instead, SiTime recommends that the customer use IPA (Isopropyl Alcohol) baths.

8 Additional Questions?

If you have any questions about the information contained in this manufacturing note or other manufacturing questions, please contact your sales representative.

SiTime Corporation
990 Almanor Avenue
Sunnyvale, CA 94085
USA
Phone: 4088-328-4400
<http://www.sitime.com>

© SiTime Corporation, 2013. The information contained herein is subject to change at any time without notice. SiTime assumes no responsibility or liability for any loss, damage or defect of a Product which is caused in whole or in part by (i) use of any circuitry other than circuitry embodied in a SiTime product, (ii) misuse or abuse including static discharge, neglect or accident, (iii) unauthorized modification or repairs which have been soldered or altered during assembly and are not capable of being tested by SiTime under its normal test conditions, or (iv) improper installation, storage, handling, warehousing or transportation, or (v) being subjected to unusual physical, thermal, or electrical stress.

Disclaimer: SiTime makes no warranty of any kind, express or implied, with regard to this material, and specifically disclaims any and all express or implied warranties, either in fact or by operation of law, statutory or otherwise, including the implied warranties of merchantability and fitness for use or a particular purpose, and any implied warranty arising from course of dealing or usage of trade, as well as any common-law duties relating to accuracy or lack of negligence, with respect to this material, any SiTime product and any product documentation. Products sold by SiTime are not suitable or intended to be used in a life support application or component, to operate nuclear facilities, or in other mission critical applications where human life may be involved or at stake.

Looking for pricing, stock, or lifecycle information?

Click below to explore more details on WIN SOURCE:

 [View SIT6085EB](#) on WIN SOURCE

 [SiTIME](#) Information

Optimize Your Supply Chain with WIN SOURCE Solutions

-  Global Sourcing Solution
-  Obsolete Management
-  Cost Control Management
-  Shortage Management
-  Alternative Solution
-  Excess Inventory Management